

The user manual

Product description:

Model number: SY-WL30B

1.1 charger input: 100-240v 50/60hz

1.2 charger output: DC5V/2A

1.3 LED lamp power: 30W light flux: 2400LM color temperature: 6500K±500K

1.4 bluetooth version/speaker: 4.2 / 3w +3W

1.5 USB output: DC 5V/1A / 5V/ 2.1A

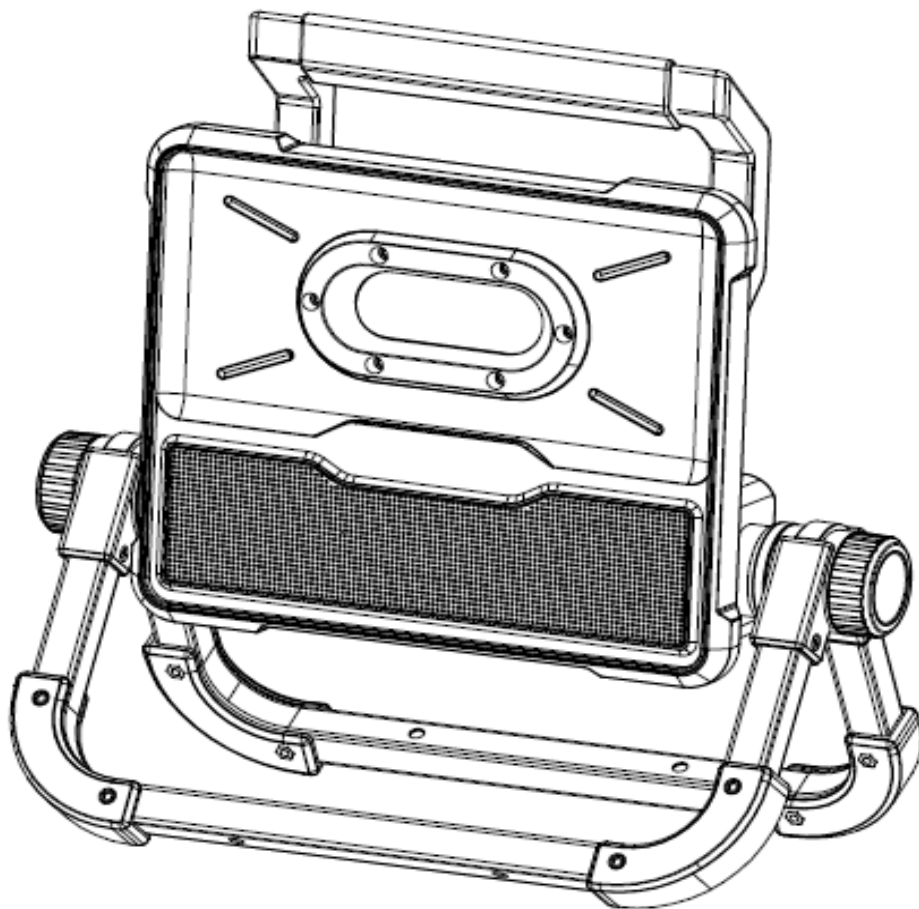

2. Description of use

2.1 LED light switch, short press the light on and off.

2.2 Bluetooth switch, long press the switch key for 3 seconds, there is a prompt tone power-on Bluetooth Mode, after releasing, long press the switch key for 3 seconds, there is a prompt tone power-off, short press music to pause/play

2.3 "+" key, short press one song, long press volume increase.

2.4 "-" key, short press the previous song, long press the volume to reduce.

2.5 USB output: DC 5V1A / 5V/ 2.1A

2.6 charging port: DC5V/2A is fully charged (three blue leds are fully bright)

This device complies with Part 15 of the FCC. Operation is subject to the following two conditions: (1) this device may not cause harmful interference, and (2) this device must accept any interference received, including interference that may cause undesired operation.

Changes or modifications not expressly approved by the party responsible for compliance could void the user's authority to operate the equipment.

This equipment has been tested and found to comply with the limits for a Class B digital device, pursuant to part 15 of the FCC Rules. These limits are designed to provide reasonable protection against harmful interference in a residential installation. This equipment generates uses and can radiate radio frequency energy and, if not installed and used in accordance with the instructions, may cause harmful interference to radio communications. However, there is no guarantee that interference will not occur in a particular installation. If this equipment does cause harmful interference to radio or television reception, which can be determined by turning the equipment off and on, the user is encouraged to try to correct the interference by one or more of the following measures:

- Reorient or relocate the receiving antenna.
- Increase the separation between the equipment and receiver.
- Connect the equipment into an outlet on a circuit different from that to which the receiver is connected.
- Consult the dealer or an experienced radio/TV technician for help.

Company name: ningbo shengye electric appliance co., LTD

Add: 87 guangming north road, yuyao simen town, ningbo, zhejiang