

## **Aries300N Orchard Sparying Robot**

### **Plant Protection Machine Manual**

**(Please Read Carefully Before Operation)**



# 1. Contents

1. Contents	2
2. Safety Instructions	6
2.2 Requirements for operation scenario	7
2.3 Operator requirements	7
2.4 Preparation before operation	8
3. Product Overview	9
3.1 Product Features	9
4. Product introduction	10
4.1 Introduction to vehicle structure	11
4.2 Remote control button function	11
4.3 Introduction to Vehicle Hardware Functions	12
5. Introduction to smart devices	13
5.1 Receiver Introduction	13
1. R70M GNSS receiver	13
2. Technical features	14
3. Technical parameters	14
3.1 Signal tracking BDS B1I/B2I/B3I	14
3.2 Physical parameters	15
5.2 Controller introduction	15

1. Product Introduction	15
2. Power supply	16
3. Controller dimensions	16
5.3 Introduction to wiring harness content	16
6. Product use	18
6.1 Introduction to start vehicle	18
6.2 Introduction to the intelligent system	19
6.2.1 Download and installation	19
6.2.2 Registration and login	19
6.2.3 Account registration	19
6.2.4 Account Login	20
6.2.5 Login by mobile phone number	20
6.2.6 Password retrieval	20
6.3 Navigation and interface layout	21
6.3.1 Introduction to the main interface	21
6.3.2 Introduction to the status bar	22
6.4 Introduction to the operation process of the intelligent system	22
6.5 Introduction to software function parameters	40
6.5.1 Vehicle settings	40
6.5.2 Straight-line debugging	41
6.5.3 Speed Debugging	42
6.5.4 Farm implement control	43
6.5.5 Safety settings	44

6.5.6 Software Tips.....	45
6.5.7 Safety Boundary.....	46
6.5.8 General Settings.....	46
7. Vehicle hardware parameters.....	47
8.Solutions to common problems.....	48
8.1 Solutions to vehicle-side problems.....	48
8.1.1 Permanent magnet motor cannot start.....	48
8.1.2 Difficulty in starting the engine.....	49
8.1.3 Abnormal output voltage.....	50
8.1.4 Abnormal engine noise.....	51
8.1.5 Engine overheating.....	51
8.1.6 Sudden engine shutdown.....	52
8.2 Intelligent system problems and solutions.....	53
9. Machine maintenance and repair.....	55
9.1 Technical maintenance.....	55
9.1.1 Maintenance per work (before and after each work).....	55
9.1.2 First-level maintenance (every 150 hours of work).....	55
9.1.3 Secondary maintenance (every 800 working hours).....	56
9.2 Daily maintenance calibration.....	56
9.2.1 Normal maintenance procedures.....	56
9.2.2 Check the engine oil.....	57
9.2.3 Gasoline engine maintenance.....	57
9.2.4 Spark plug replacement.....	58

9.2.5 Maintenance of the whole machine	58
9.2.6 Maintenance of the spray nozzle	58
9.2.7 Filter maintenance	59
9.2.8 Fan maintenance	59
9.2.9 Analysis of common faults of high-pressure water pumps	60
10. List information	62
10.1 Accessories list	62
10.2 Wearing parts	63
11. Three Guarantees Agreement	64
Service Process	66
12. Disclaimer	67

## 2. Safety Instructions

### 2.1 Instructions for Use

1. Familiarize the operating manual: Before use, be sure to carefully read the operating manual of the equipment to understand its functions, operating methods and precautions.

2. Work site Assessment: Ensure that the work site is suitable for the operation of the intelligent driving pesticide sprayer, and there are no obstacles, steep slopes, soft ground and other factors that may affect its safety and normal operation.

3. Pesticide preparation: Prepare pesticides correctly as required, pay attention to the properties and compatibility of pesticides, and avoid improper use that may lead to reduced efficacy or adverse reactions.

4. Battery and fuel: Ensure that the vehicle's battery power is sufficient or the engine supply is stable, and regularly replenish and replace gasoline, engine oil, and gear oil.

5. Positioning and navigation settings: Correctly set the vehicle's positioning and navigation system to ensure that it can accurately drive and operate according to the planned route.

6. Safety distance: During operation, personnel must maintain a safe distance from the pesticide sprayer to avoid contact with pesticide spray.

7. Regular maintenance: Maintain the pesticide sprayer according to the specific time and requirements, including checking mechanical parts, filtration systems, nozzles, etc.

8. Troubleshooting: If you encounter equipment failure or abnormal situation, you should stop using it immediately and contact professionals for troubleshooting.

9. Data management: Properly manage the data generated during the operation of the vehicle, such as driving path storage, operation records, etc.

10. Training and qualifications: Operators should receive professional training and have the corresponding operating qualifications and skills.

11. Safety warning signs: Set up obvious safety warning signs in the operation area to remind others to pay attention.

## **2.2 Requirements for operation scenario**

1. Weather conditions: Avoid using in bad weather conditions such as strong winds, heavy rains, lightning, etc., in case not to affect the operation effect and equipment safety.

2. Relatively open and flat: Ensure that the sprayer can drive smoothly and avoid driving difficulties or accidents due to complex terrain.

3. Fewer obstacles: Reduce the risk of collision and ensure that it can operate stably according to the planned route.

4. Good communication signal: Facilitate effective data transmission and command reception with the control end or operation end.

5. Wear safety protection measures: Prevent pesticides from causing potential harm to personnel.

6. Moderate wind speed: excessive wind speed may cause pesticide drift, affecting the effect of pesticide application and environmental safety.

7. Relatively stable weather conditions: avoid using in severe weather conditions such as heavy rain, thunder and lightning.

8. Suitable crop growth conditions: for example, the height of the plant cannot be too low to affect the passage of the sprayer, etc.

## **2.3 Operator requirements**

1. Relevant knowledge: understand the basic principles of intelligent driving technology, the functions and operation procedures of the vehicle.

2. Receive professional training: be familiar with emergency response

methods, understand vehicle monitoring and management.

3. Able to remotely monitor: monitor the operating status of the vehicle at any time, and promptly discover and handle abnormal situations.

4. Good judgment ability: be able to make reasonable decisions quickly in special circumstances, such as whether manual intervention is required.

5. Emergency response capabilities: be able to calmly and effectively take countermeasures in the face of emergencies.

6. Comply with relevant laws and regulations and operating procedures: ensure that the use of the vehicle is legal and compliant.

## **2.4 Preparation before operation**

1. Check equipment status: check whether the mechanical structure of the vehicle body, remote control system, nozzle, etc. are normal, and whether there is any damage or looseness.

2. Check the power or fuel: Ensure that the energy is sufficient to support the expected operation tasks.

3. Pesticide preparation: Accurately prepare the required pesticides according to the requirements and ensure that their quality and concentration are appropriate.

4. Calibration of the navigation system: Confirm that the base station connection is normal, the navigation positioning is accurate, and the route planning is correct.

5. Communication system test: Ensure that the communication between the operation and the vehicle execution is smooth, and the action is executed correctly.

6. Safety device inspection: such as the emergency stop button and the emergency stop button work properly on the remote control.

7. Work environment investigation: Confirm again that there are no new



obstacles in the work area, and the ground conditions are suitable for operation.

9. Data recording equipment inspection: Ensure that various data during the operation process can be recorded normally.

10. Warning sign preparation: Place necessary warning signs around the work area to warn others.

### **3. Product Overview**

Aries300N intelligent plant protection robot is a crawler plant protection robot equipped with a range extender power system. It adopts the "ultra-high pressure + wind delivery" atomization method. The droplet atomization particle size is as fine as 100-500 $\mu$ m, and the spray reaches 6-8m. The Aries300N intelligent plant protection robot integrates Beidou high-precision satellite technology, and integrates safety systems, intelligent perception, automatic navigation, precision operations, and intelligent management. Complete intelligent, safe, and efficient plant protection operations in various scenarios.

#### **3.1 Product Features**

1. Even application of pesticides, saving water and pesticides: The atomization particle size is as fine as 100-500 $\mu$ m, and the spray width can reach 6-8m, which can save about 30% of water and pesticides.

2. Universal nozzle, full coverage: According to the row spacing and tree height, the nozzle angle could be adjusted, so the fruit tree plant protection can be fully covered.

3. From bottom to top, directly hit the back of the leaves: The spray method is from bottom to top, which allows the liquid directly hit the back of the leaves that are prone to diseases and pests.

4. Night operation, better prevention effect: It also has the ability to operate plant protection at night. Night plant protection operations not only

can avoid high temperature weather, but also the operation effect will be double since pests more active at night.

5. Economic benefits: Compared with traditional operation methods, UTS300 can save about 50% of water and medicine, and the operation efficiency is as high as 200 acres/day.

6. Scope of application: UTS300 can be widely used in mountain orchards, hilly orchards, plain grasslands.

7. Integrate satellite navigation and inertial navigation technology to solve complex scene positioning problems such as weak signals, achieve navigation accuracy of  $\pm 2.5\text{CM}$ , and ensure high-quality operation.

8. Exquisite structural design: crawler chassis, strong adaptability, rotating low body in place, and shuttle freely in the orchard.

9. Safety system: The software safety system and physical obstacle hardware complement each other to monitor and alarm the entire operation process to ensure safe operation.

10. Free mode switching, manual remote control, smart APP remote control, smart remote platform control and other control methods can be switched at will, remote operation, and human-machine separation can be achieved.

11. The intelligent operating system achieves intelligent and efficient operation through precise control of the environmental perception system, path planning system, vehicle control system, and equipment.

12. Rich software functions: equipped with APP software, a glance at the operation information data, plot information collection, path planning, remote task sending, execution, one machine with multiple controls.

13. Stable and reliable upgrade function: Provides equipment online upgrade and remote upgrade functions.

## **4. Product introduction**

### 4.1 Introduction to vehicle structure

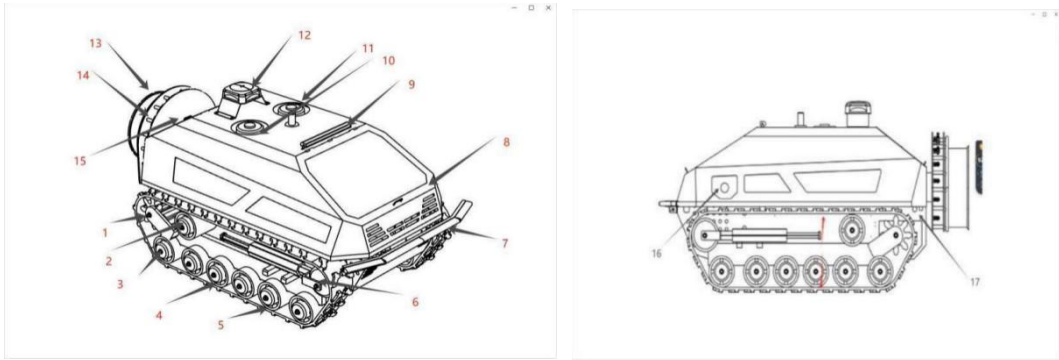

(1) Driving wheel	(10) Liquid medicine inlet
(2) Support wheel	(11) Water tank cover
(3) Support roller	(12) GNSS receiver
(4) Dust cover	(13) Fan
(5) Rubber track	(14) High-pressure water pump
(6) Guide wheel	(15) Drive controller
(7) Anti-collision strip	(16) Exhaust pipe
(8) Upper cover	(17) Battery
(9) Headlight	

### 4.2 Remote control button function



introduction

(1) Left F1 switch	Left liquid pump switch control
(2) Right F2 switch	Right liquid pump switch control
(3) Button A	Ignition and shutdown control
Button B	Fan switch control
Button C	Headlight control

(4) Aileron rudder forward and backward control	Vehicle forward and backward
(4) Aileron rudder left and right control	Vehicle left and right turn
(5) Main wing rudder	Not yet developed
(6) Speaker	
(7) Interface attributes	Type-c port
(8) Interface attributes	Upgrade port
(9) Card slot attributes	SIM card slot
(10) Card slot attributes	TF card slot

### 4.3 Introduction to Vehicle Hardware Functions

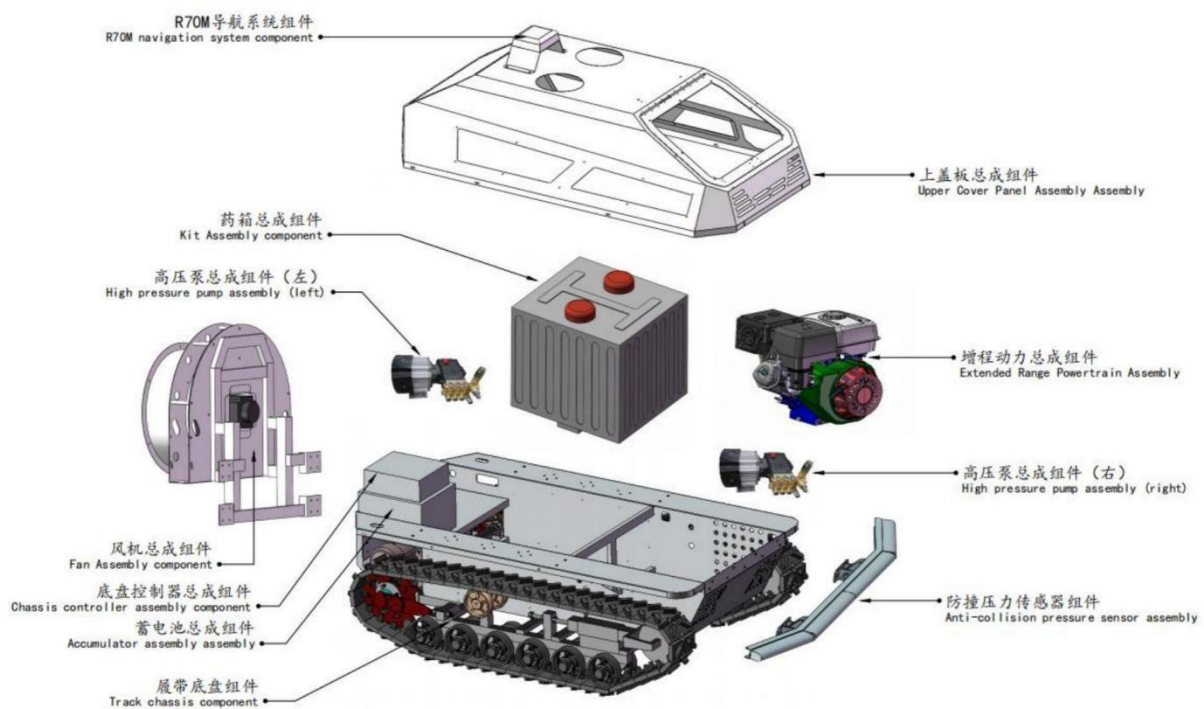

No.	System name	Main ingredients
1	Intelligent driving navigation system	GNSS receiver, controller,
2	Air-assisted	Filter, motor, air atomizer, water

	atomization system	pump, and nozzle.
3	Power system	Engine, 48V battery pack, electric drive system
4	Crawler bottom system	Crawler chassis
5	Medicine box storage system	Medicine box, water pipe

## 5. Introduction to smart devices

### 5.1 Receiver Introduction



#### 1. R70MGNSS receiver

R70M GNSS receiver is an Android platform high-performance integrated receiver designed for intelligent driving solutions for agricultural machinery. The built-in high-precision multi-function antenna is easy to install, and the internal integration of high-precision dual-antenna Beidou multi-star

positioning and orientation board, attitude sensor, digital radio module, dual 4G, etc. The main control chip is an 8-core processor with a main frequency of up to 2GHz, pre-installed with intelligent control intelligent software, and the Android platform facilitates customers' secondary development to meet the various needs of different customers.

The high-precision positioning and orientation function meets many application scenarios such as precision agriculture, digital engineering, intelligent driving, and intelligent driving. The IP67 protection level of the whole

machine can adapt to harsh working environments.

## 2. Technical features

### 2.1. Adopting Beidou, GPS, GLONASS, Galileo and other multi-star

multi-frequency systems, it can ensure positioning accuracy in a variety of complex environments and realize single Beidou solution;

2.2. Built-in digital radio communication module, supports a variety of communication protocols, such as transparent transmission, TRIMTALK, CSS protocol, etc., and can be seamlessly compatible with multiple radios;

2.3. Wide voltage power supply, voltage range 9 ~ 36V DC, with positive and negative polarity reverse connection protection;

2.4. Android system platform, supports remote diagnosis and remote setting, convenient for users to remotely maintain the system and reduce user maintenance costs;

2.5. Supports a variety of screen projection methods (network remote projection, USB projection and WI FI projection), operation and debugging visualization is more convenient and faster;

2.6. Standard IP67 waterproof and dust proof design, high protection level;

2.7. Built-in high-precision six-axis gyroscope, realizes high-precision attitude measurement, and can ensure accuracy in all terrains

## 3. Technical parameters

### 3.1 Signal tracking

BDS B1I/B2I/B3I

GPS L1C/A/L2P (Y) /L2C/L5

GLONASS G1/G2

Galileo E1/E5a/E5b

QZSS L1/L2/L5

Cold start time: <30s

Initialization time: <5s (typical value)

RTK initialization reliability: >99.9%

Recapture: <1s

### 3.2 Physical parameters

Triple-proof design: Standard IP67 dust proof and waterproof, strong shock resistance, and 2m drop resistance

Antenna interface: GNSS interface 1, RADIO interface\*1

Data interface: AMP26P (4-channel AHD, 3-channel RS232, 2-channel CAN, 1-channel RS485, 1-channel power supply)

Dimensions: 182mm×182mm×72mm

### 3.3 Physical performance

Operating temperature: -20°C ~ +60°C

Storage temperature: -55°C ~ +85°C

## 5.2 Controller introduction



### 1. Product Introduction

The hydraulic controller is an interventional vehicle operation controller developed for the intelligent operation of agricultural vehicles, including hydraulic valve control, analog signal acquisition, RS485 communication, RS232 communication, CAN communication and other functions. The overall circuit adopts a modular design with strong compatibility. It can be used in conjunction with the automatic driving system or alone.

In the field of smart agriculture, it can be widely used in tractors, harvesters and sprayers, etc., and the automatic driving system can meet the intelligent operation needs of agricultural vehicles. It helps the entire smart farm to run

smoothly, further improve operation efficiency, enhance operation quality, reduce labor intensity, reduce waste of agricultural materials, and improve economic benefits.

## 2. Power supply

The controller is designed for DC8-36V power supply (when the input voltage is lower than 8V, the power supply circuit stops working and does not output voltage). Considering the need to meet the driving torque of the controlled components (such as hydraulic valves), it is recommended to use the original DC12V battery of the vehicle and use DC12V power supply (with power protection function). The specific parameters are as follows:

Power supply voltage: DC12V (8-36V);

Power supply current: MAX3A@DC6V (excluding power components);

## 3. Controller dimensions

The controller dimensions are 174.9mm\*161.9mm\*47.5mm (including connector length, connector length is 15.5mm, controller length is 159.4mm).

## 5.3 Introduction to wiring harness content

Analysis diagram of R70M main wiring harness interface

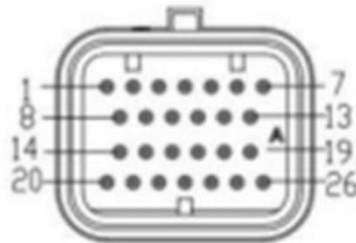



序号	定义	备注	序号	定义	备注
1.	B+	电源正级	14.	RS232_1-TX	
2.	B-	电源负级	15.	GPIO INPUT_2	
3.	ACC		16.	CAMERA-CVBS_1	
4.	CAN_1-H		17.	RS232_2-RX	
5.	CAN_1-L		18.	RS232_1-RXCAMERA/RJ45-TX-	
6.	12V-OUTPUT		19.	RS232_1-TXCAMERA/RJ45-RX-	
7.	CAMERA-CVBS_3		20.	RS232_1-RX	
8.	GND	信号地	21.	GPIO INPUT_1	
9.	RS485-A		22.	CAMERA-CVBS_0	
10.	RS485-B		23.	CAMERA-12V	
11.	CAN_2-H		24.	RS232_2-TX	
12.	CAN_2-L		25.	RS232_2-RXCAMERA/RJ45-TX+	
13.	CAMERA-CVBS_2		26.	RS232_2-TXCAMERA/RJ45-RX+	

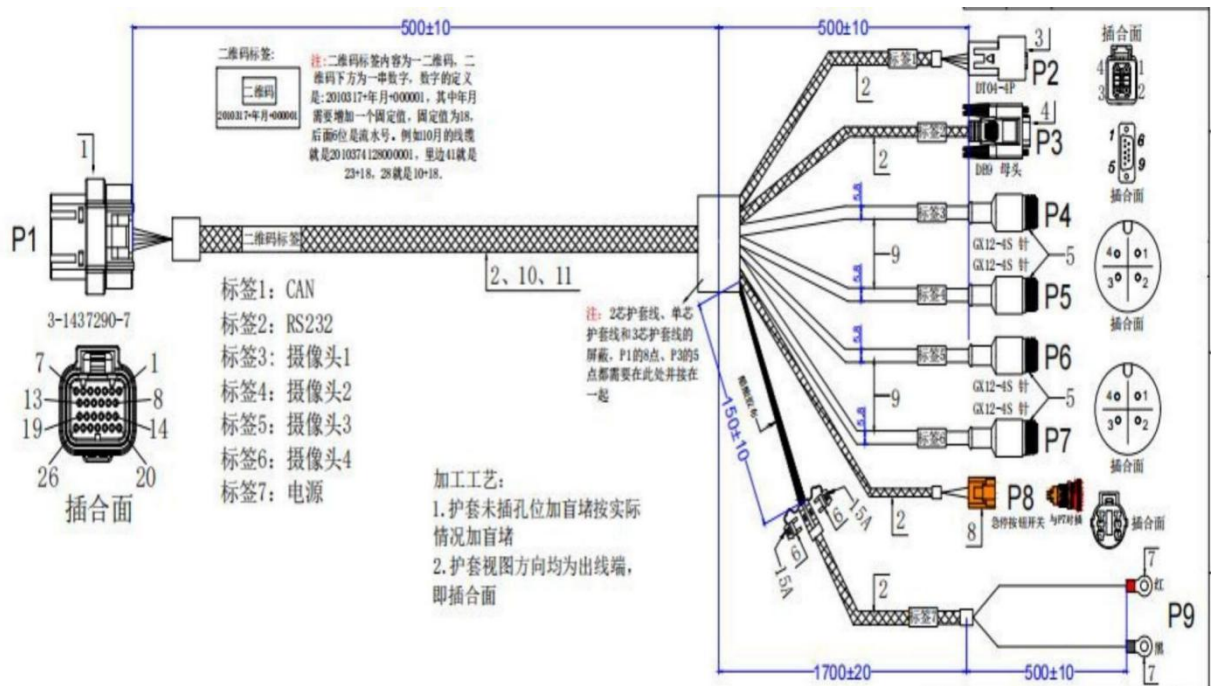

## 6. Product use

### 6.1 Introduction to start vehicle

1. Turn on the remote control: Press and hold the on/off key, and wait for the light to turn green, which means it is connected.

2. Power on the vehicle: Press the power switch on the left rear of the device to the ON position;

3. Walking test: Control the device "forward/backward" and "left/right rotation" through the remote control;

4. Start the range extender: Turn on the range extender start/stop switch "A" on the remote control;

Note: When the engine is cold started, close some air intakes to increase the gasoline concentration of the mixture entering the cylinder, and improve the starting performance of the engine. The choke should be fully opened after the engine is running normally.

5. Enter the starting point of the operation: Plan the plot information in advance, make an operation plan, drive the equipment to the starting point, and prepare for the operation;

6. Start the pressure pump: Turn the upper left and upper right switches on the remote control respectively, and the left and right pressure pumps will be turned;

7. Operation: Control the joystick on the right side of the remote control to make the device "forward/backward" and "left/right rotation" to complete the plant protection operation. For night operations, turn on the "switch C" of the remote control to turn on the night light.

8. Remote control mode switching: the middle button is on the far left for remote control mode, and on the far right for intelligent control mode (turn the button to the far right before performing the operation)

## 6.2 Introduction to the intelligent system

### 6.2.1 Download and installation

1. Scan the QR code/or copy link to download our App software.
2. After download, click the install button and follow the prompts to complete the installation process.
3. If you need to uninstall the software, long press the App icon, select Uninstall or drag the trash can icon at the bottom to uninstall.

### 6.2.2 Registration and login

1. Open the installed App software, you need to register an account first and provide the required personal information to complete the registration process.
2. After registration, log in to the system with your username and password.
3. Log in directly by remembering the password, which is valid for 1 year.

### 6.2.3 Account registration

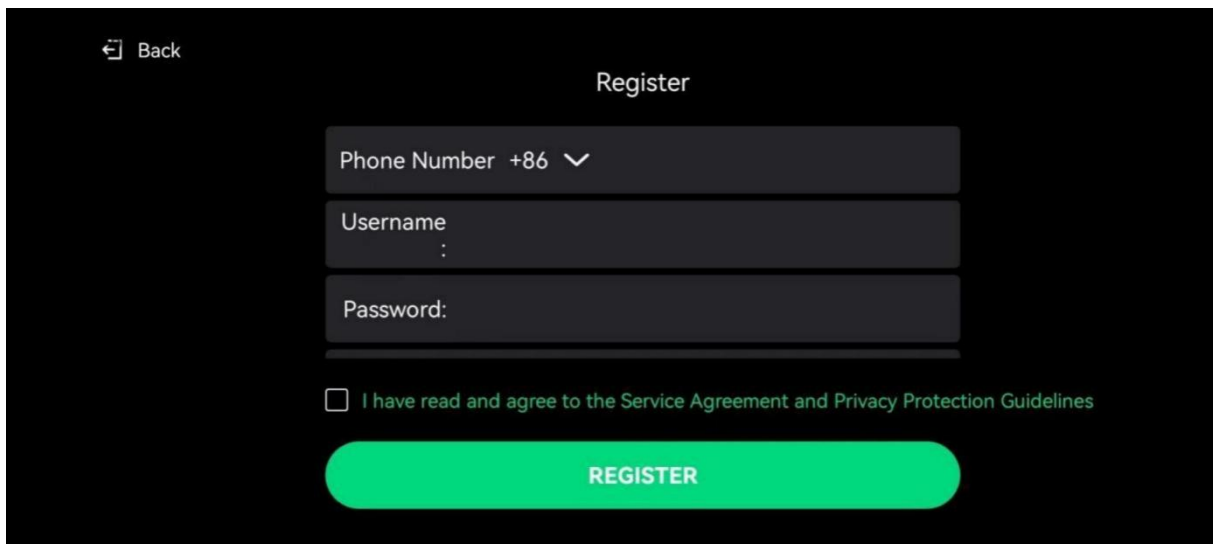

← Back

Register

Phone Number +86 ▾

Username

:

Password:

I have read and agree to the Service Agreement and Privacy Protection Guidelines

REGISTER

## 6.2.4 Account Login

(Enter your phone number + password)

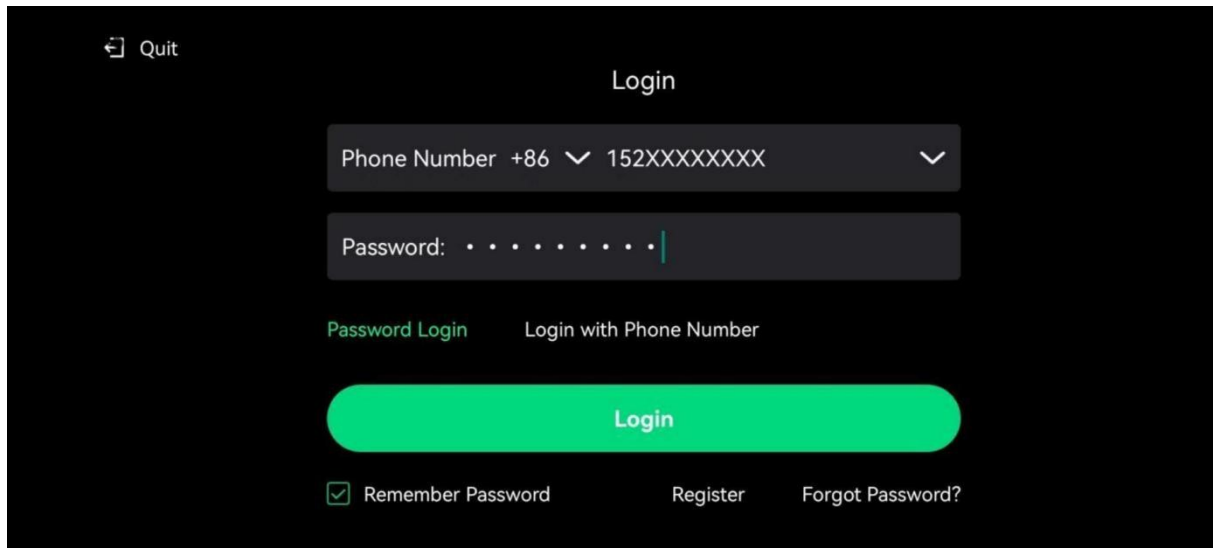

The screenshot shows a mobile application interface for account login. At the top left, there is a 'Quit' button with a back arrow icon. The title 'Login' is centered at the top. Below the title, there is a form with two input fields: 'Phone Number' with a dropdown menu showing '+86' and a text field containing '152XXXXXXXXX', and 'Password' with a masked input field showing eight dots. Below the form, there are two options: 'Password Login' (highlighted in green) and 'Login with Phone Number'. A large green 'Login' button is centered below these options. At the bottom, there is a 'Remember Password' checkbox (checked), and links for 'Register' and 'Forgot Password?'.

## 6.2.5 Login by mobile phone number

(Enter mobile phone number + SMS verification code)

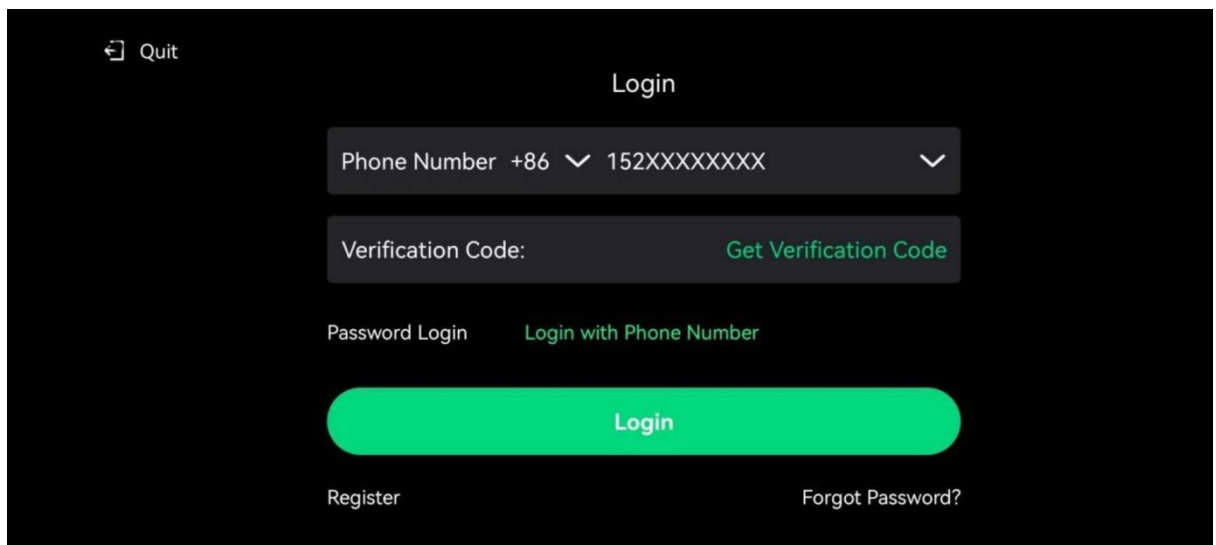

The screenshot shows a mobile application interface for login by mobile phone number. At the top left, there is a 'Quit' button with a back arrow icon. The title 'Login' is centered at the top. Below the title, there is a form with two input fields: 'Phone Number' with a dropdown menu showing '+86' and a text field containing '152XXXXXXXXX', and 'Verification Code' with a text field and a 'Get Verification Code' link. Below the form, there are two options: 'Password Login' and 'Login with Phone Number' (highlighted in green). A large green 'Login' button is centered below these options. At the bottom, there are links for 'Register' and 'Forgot Password?'.

## 6.2.6 Password retrieval

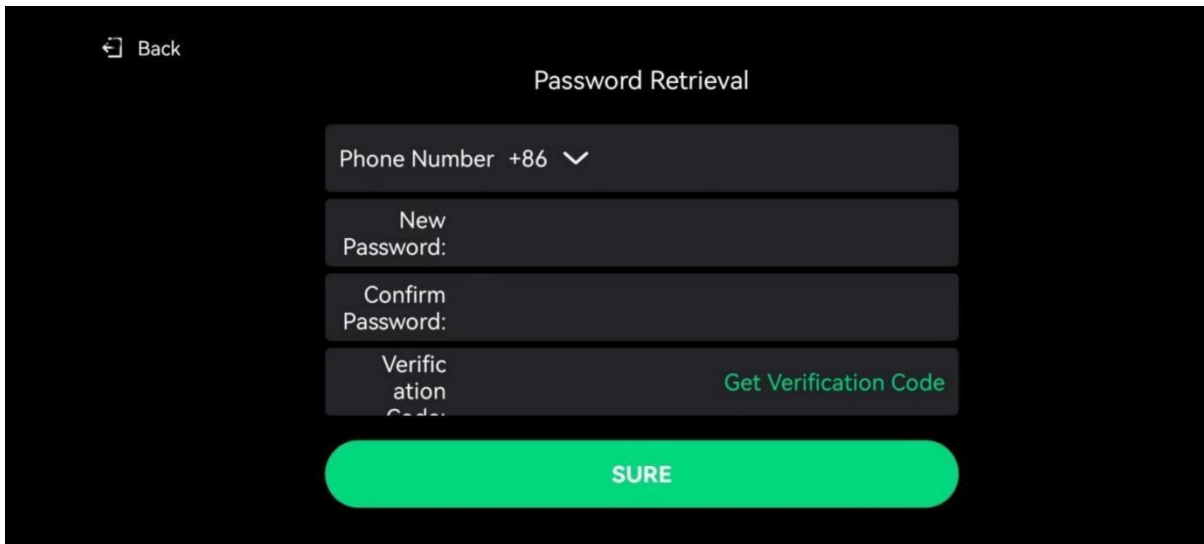

### 6.3 Navigation and interface layout

The App software has several interface elements such as navigation bar, tab bar, sidebar or sliding menu for browsing and accessing different function pages. According to needs, you can switch between different pages and operate by clicking or sliding.

#### 6.3.1 Introduction to the main interface

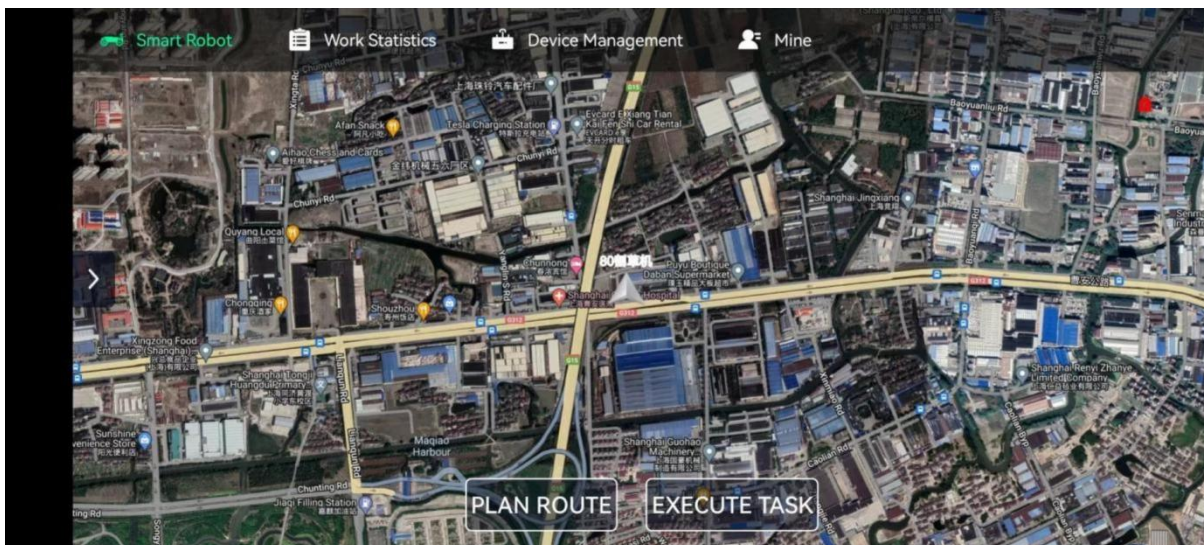

1. Intelligent robot: will automatically pull the bound vehicles under the registered account name and the vehicles granted permissions through sharing;
2. Operation statistics: statistics of the information of the completed operations, you can view the operation area, duration, etc.;
3. Equipment management: for users to view and set equipment, including

vehicles, base stations, etc.;

4. Mine: that is, software management, users can view software information;

5. Planning path: used to plan plots and operation routes;

6. Execute operations: start the operation after importing the plots and paths to be operated;

### 6.3.2 Introduction to the status bar

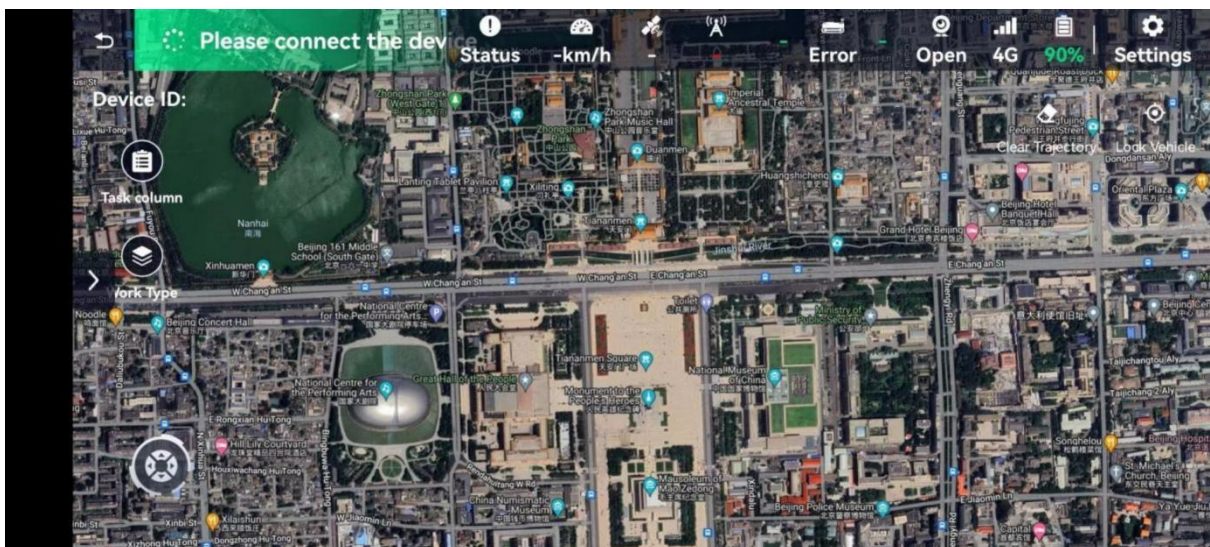

1. Device status display
2. Number of satellites
3. Base station status
4. Online error display
5. Camera switch
6. Network signal display
7. Battery display
8. General settings

### 6.4 Introduction to the operation process of the intelligent system

1. Each App software has specific functions and operation methods to meet specific needs.

2. You can access various function pages through icons or labels on the

navigation bar or sidebar.

3. On each function page, you can use corresponding operation elements (such as buttons, input boxes, sliders, etc.) to interact with the App.

4. Some functions may involve personal information or sensitive operations. Please read and understand the relevant tips and precautions carefully before use.

Operation flow chart

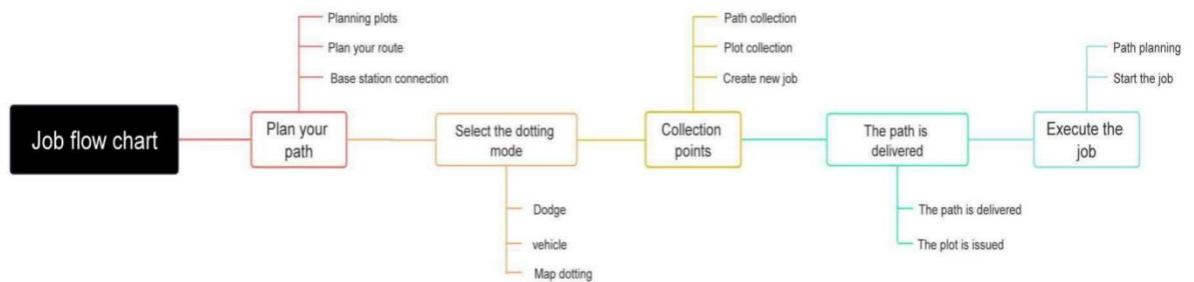

6.4.1 Account login,

1. After login, the software will automatically pull the bound vehicles under the registered account name and the vehicles granted permissions through sharing

2. Vehicle connection (click to select the online vehicle, and the "Confirm Connection" prompt box will automatically pop up)

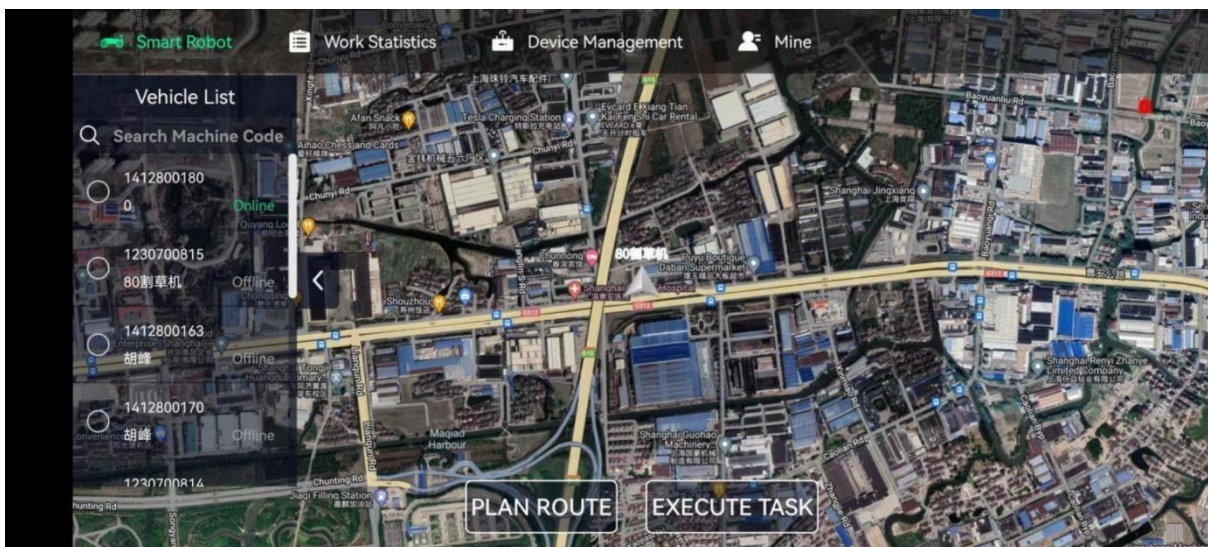

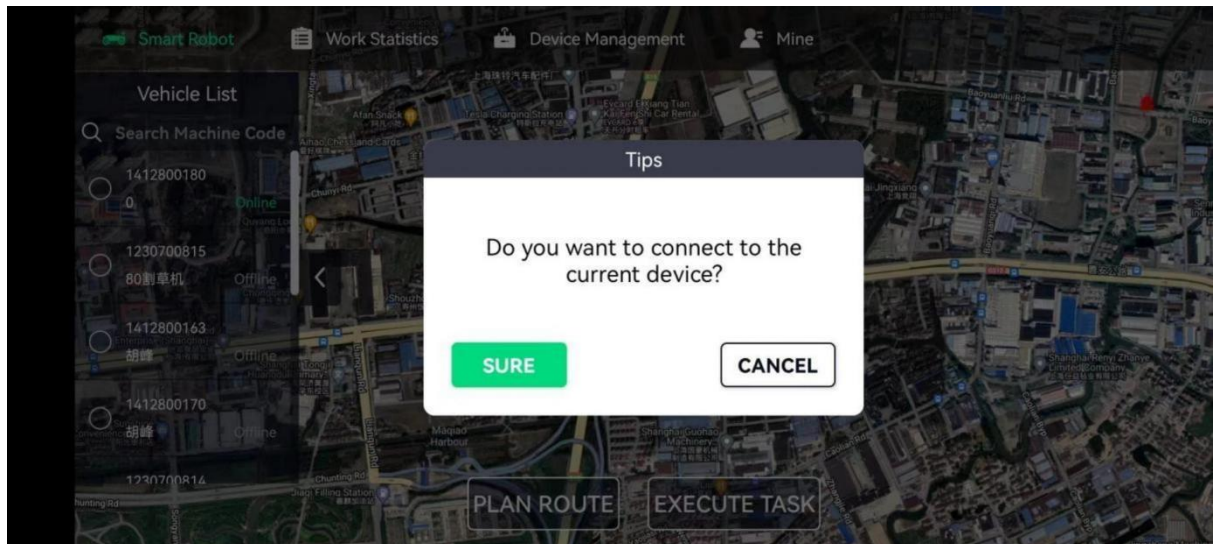

3. Disconnect (Click the connected vehicle, and a "Disconnect" prompt box will pop up automatically)

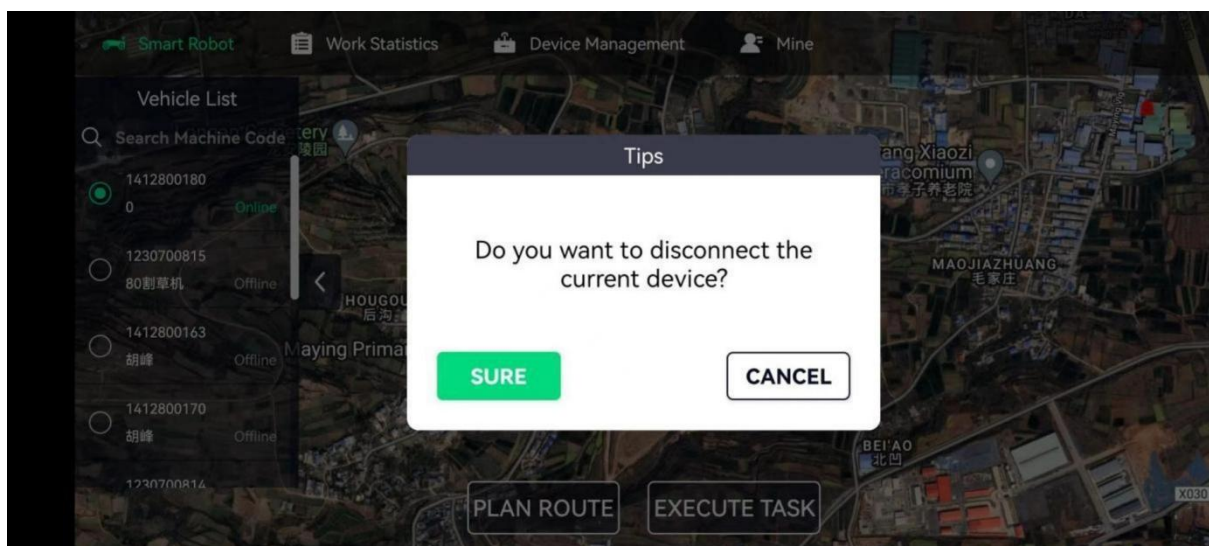

4. Vehicle alarm (there is a red "alarm bell" in the upper right corner, it is to remind you of the vehicle's operating status and alarm information during controlling multiple vehicles. According to the alarm and prompt, we could make an action in time to solve the problem.)



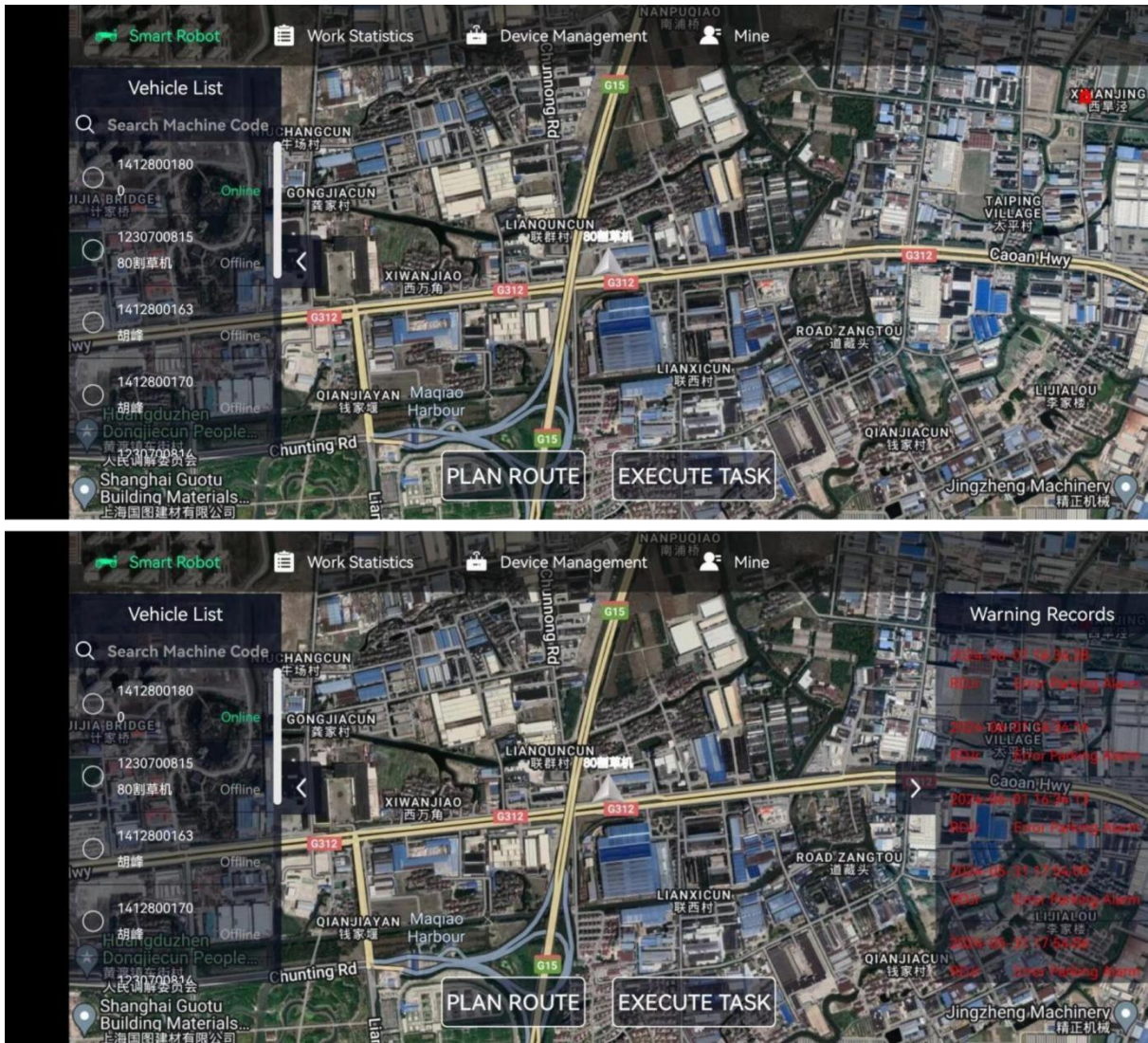

Vehicle management (My Vehicle: You can query all vehicles under the current login account)

1. Edit vehicle: Edit vehicle information, and change the vehicle type and name

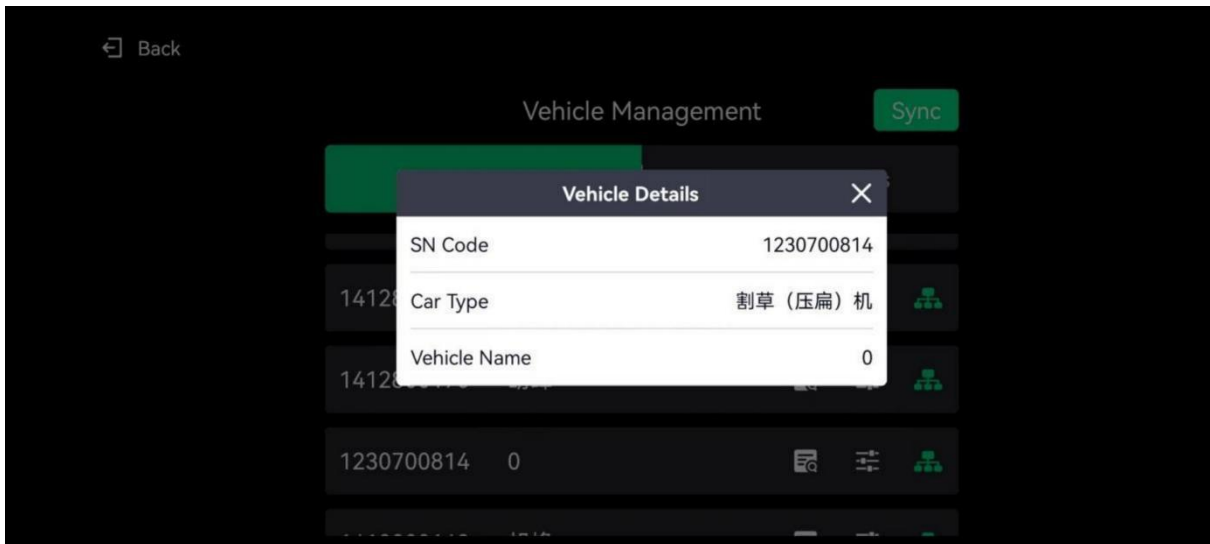

2. Sharing Permission: "Add a new vehicle" for authorization management, and "Cancel sharing" to revoke permissions

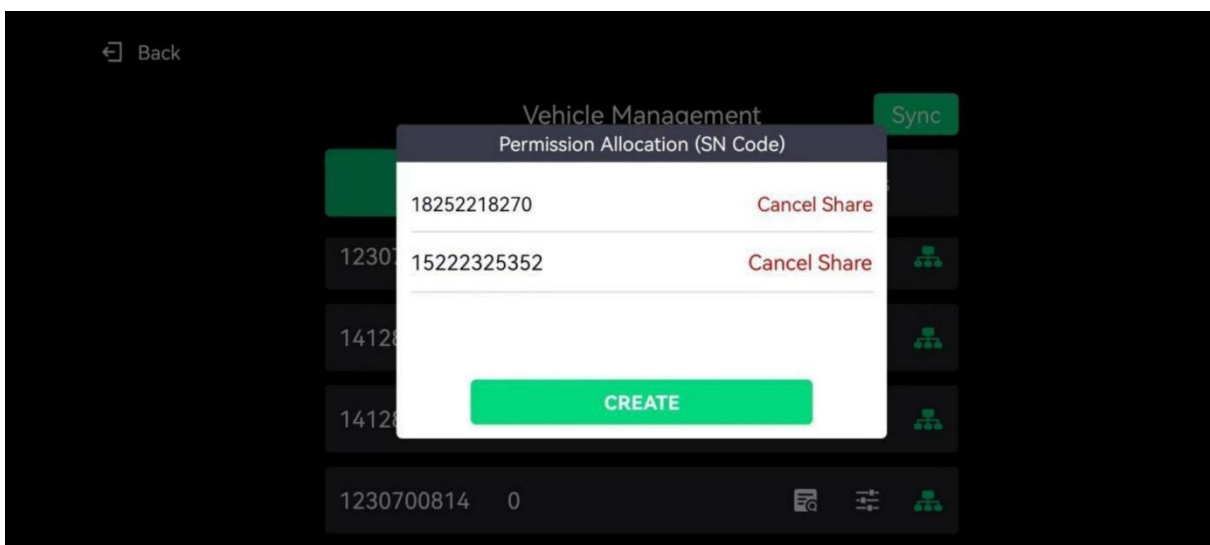

3. Accept vehicle: Grant other accounts vehicle permissions. After other accounts log in, they need to receive the device.

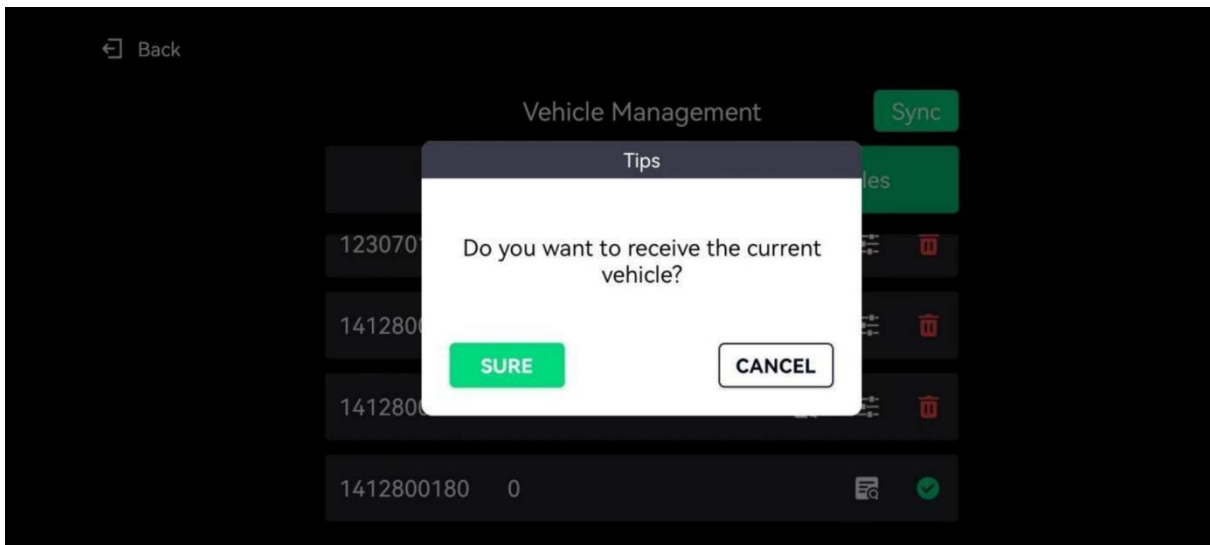

#### 6.4.2 Base station connection

1. The base station connection modes include network base station, CORS, one-click fixation, Qianxun, and radio; generally one-click fixation

2. Provide connection services for the vehicle's base station and obtain different differential data;

3. When selecting different base station connection modes, other communication modes are closed by default, and only the current connection mode is retained

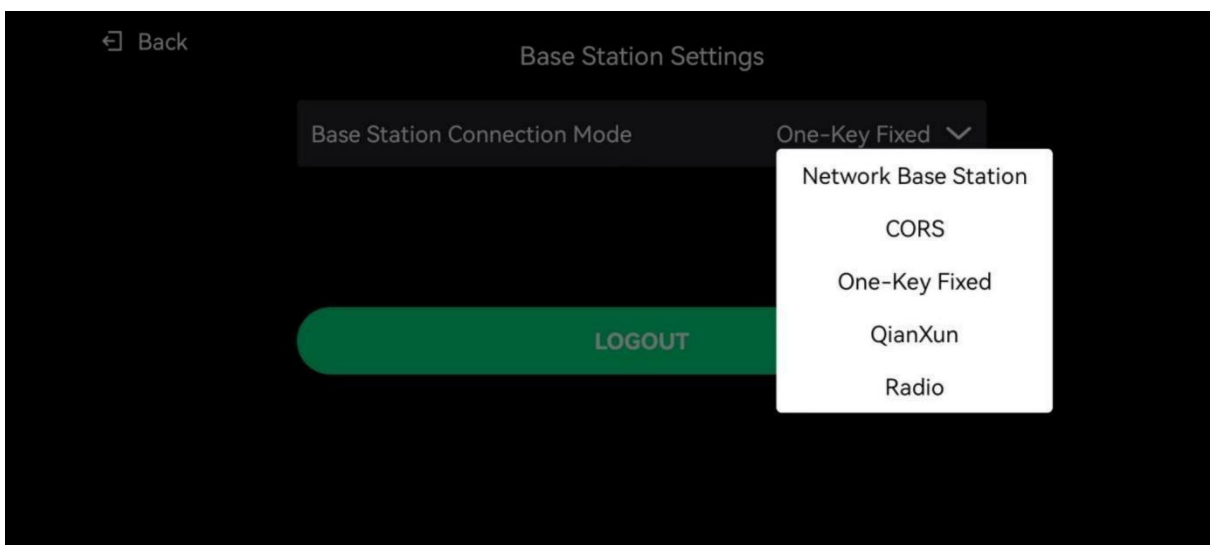

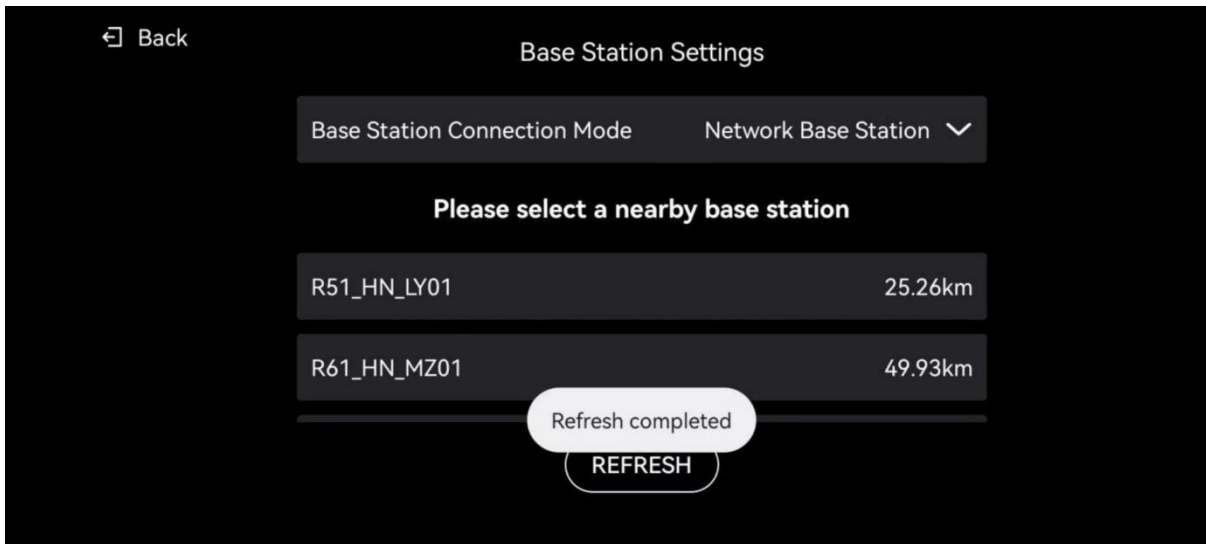

### 6.4.3 Radio connection

#### 1. Introduction to R26L panel functions

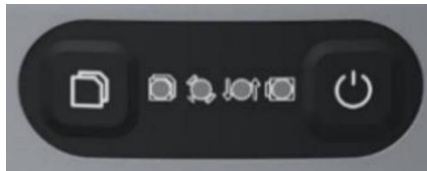

From the left to the right of the picture, they are:

Static recording button: long press for 5 seconds to turn on or off the static recording mode;

Static mode working indicator: flashes red when the static recording mode is turned on, otherwise it goes out;

Satellite indicator: flashes red when receiving satellites, otherwise it goes out;

Data transmission indicator: flashes red when transmitting differential data, otherwise it goes out

Power light: three-color light, Charging: light blue is on. Full: green is on. Working: green is on. Power is less than 10% and flashes red.

Power button: long press for 3 seconds to turn on. After turning on, long press for 3 seconds to ask whether to shut down, short press once to shut down, long press for 3 seconds to enter the self-test mode.

Note: Long press the static recording button and the power button together

until the four indicators light up together and the red indicator light is restored to factory settings.

2. Open the Surveying and Mapping Ultimate Edition and connect in the configuration interface connection.



3. Turn on Bluetooth, search for the device's SN number, click Connect, and after the connection is complete, return to the previous level.



#### 4. Configure in the base station settings

##### 4.1 Startup parameters

Differential mode division: RTCM32

Altitude cutoff angle: 5

Startup mode: Single point positioning start

##### 4.2 Differential data broadcast parameters (radio mode selection)

There are two radio modes: built-in radio mode and external radio mode.

##### 4.3 Built-in radio mode

Select the appropriate channel, 1-7 are the default frequency channels, and 8 channels can customize the frequency. The base station protocol can select the appropriate protocol.

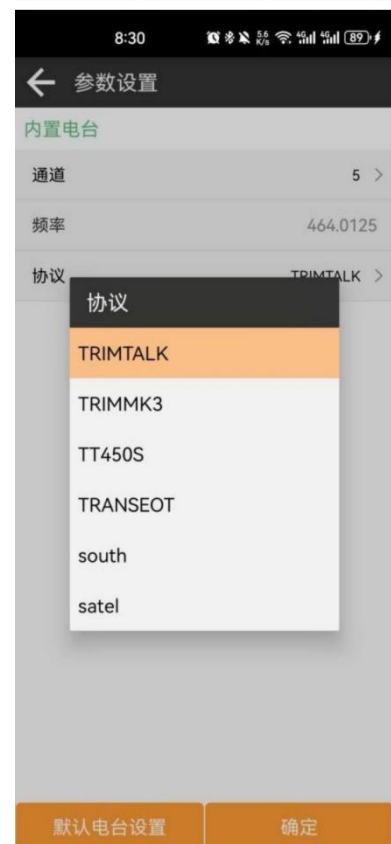

Note 1: 1-7 default channel frequencies

1	460.0125
2	461.0125
3	462.0125
4	463.0125
5	464.0125
6	465.0125
7	466.0125

Note 2: Protocol selection, different protocols can be selected according to different radio models. 1018D+ radio can choose protocols: TRIMTALK, TRANSEOT, TRIMMARK3, etc., 2029D radio can choose protocols: SP Protocol, CSS, M5 radio can choose protocols: SP Protocol, CSS, TRIMTALK, TRANSEOT, TRIMMARK3, etc.

Note 3: After selecting SP Protocol, choose to set the base station ID, any number within 10 digits.

5. Connect the host computer to the radio

After opening the software and connecting the vehicle, in the execution interface, click the signal tower, enter the base station settings, select the base station connection mode, change to radio, and set the corresponding receiving frequency and radio protocol.



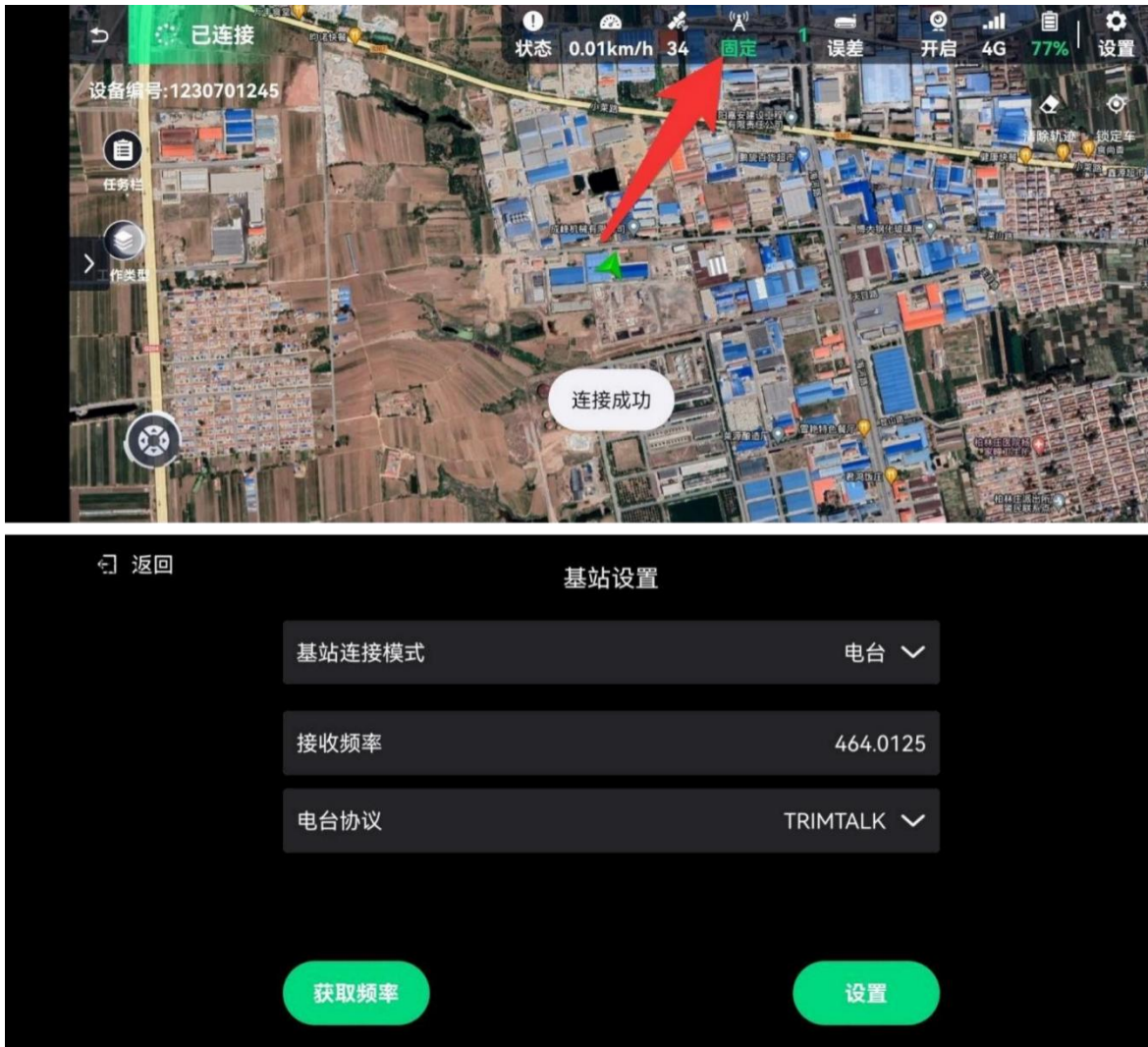

#### 6.4.4 Planning Path

1. Planning path is divided into planning path and planning plot mode
2. Planning path, you can use A-B path following mode, A-B U-turn mode, A-B reciprocating mode
3. Planning plot, planning multi-point plot



### 6.4.5 Collection Path

1. After selecting the planning mode, select the collection mode of the point collection function, mainly the vehicle point collection mode, and the map point collection mode is under development.



## 2. Create a newjob: Create a newjob task

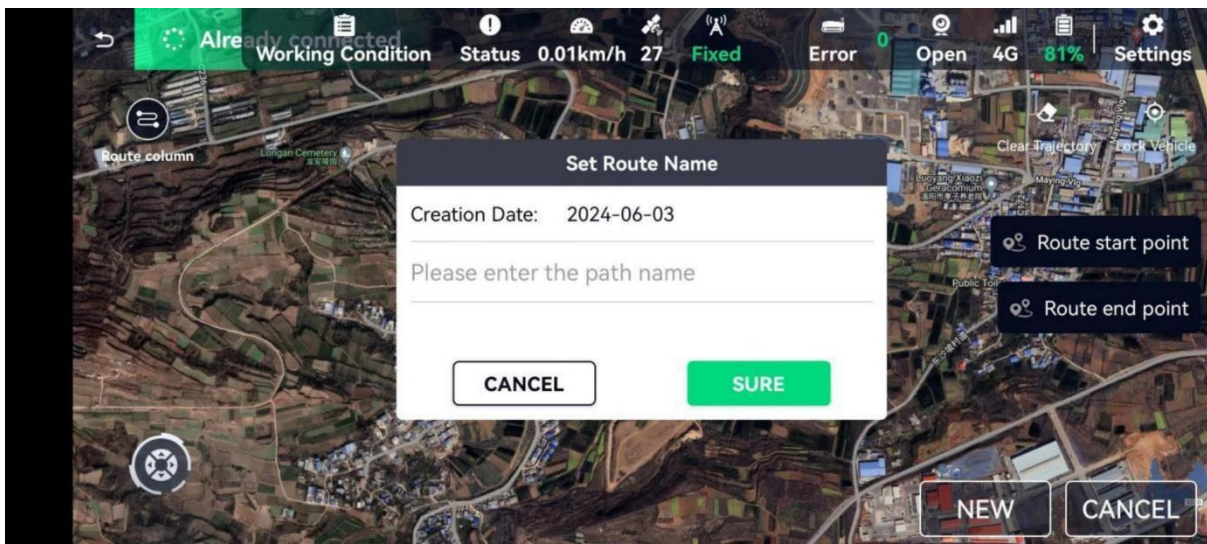

3. Path point collection: directly collect "path points". This function only collects the starting point and end point of the path. After the collection is completed, click "Save".

4. Plot point collection: directly collect "path points". Collect the points that need to be marked. After the collection is completed, click "Save".

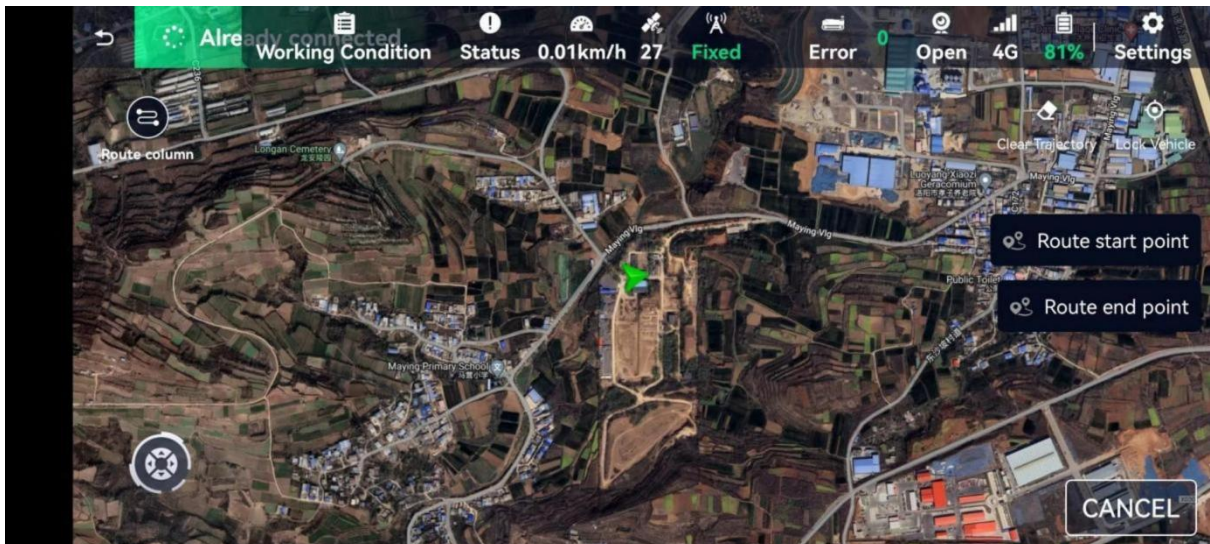

### 6.4.6 Path Distribution

5. After the path is marked, the name of the currently collected path/plot will be automatically displayed in the "Job Bar" on the left.

6. Edit Path: You can edit the path by simply adding points to the path.

7. Distribute Path: Distribute the path directly to "Execute Job" and jump to the interface.

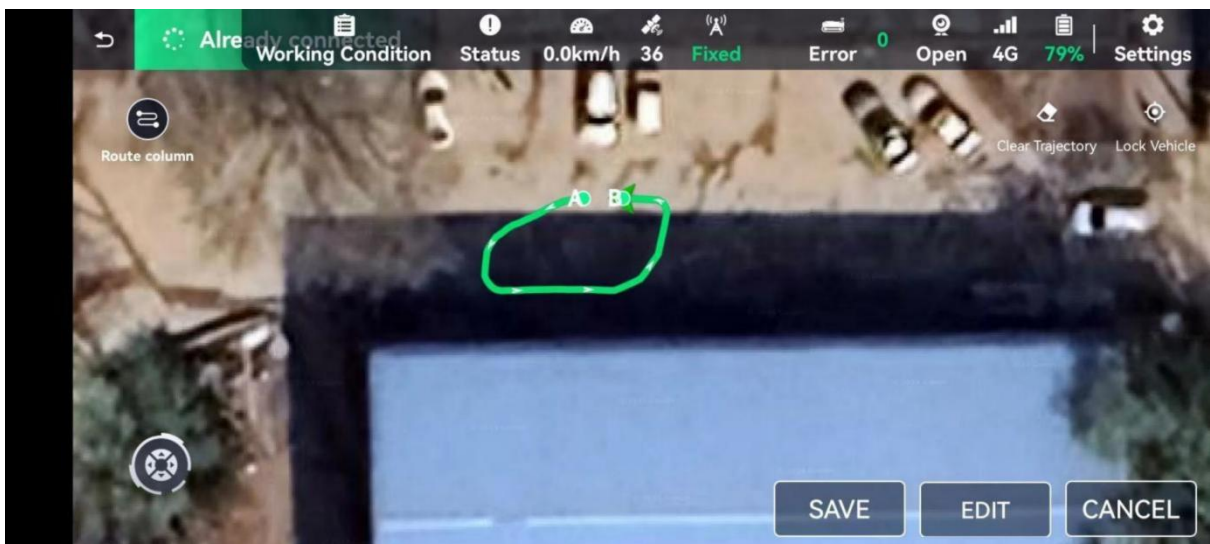

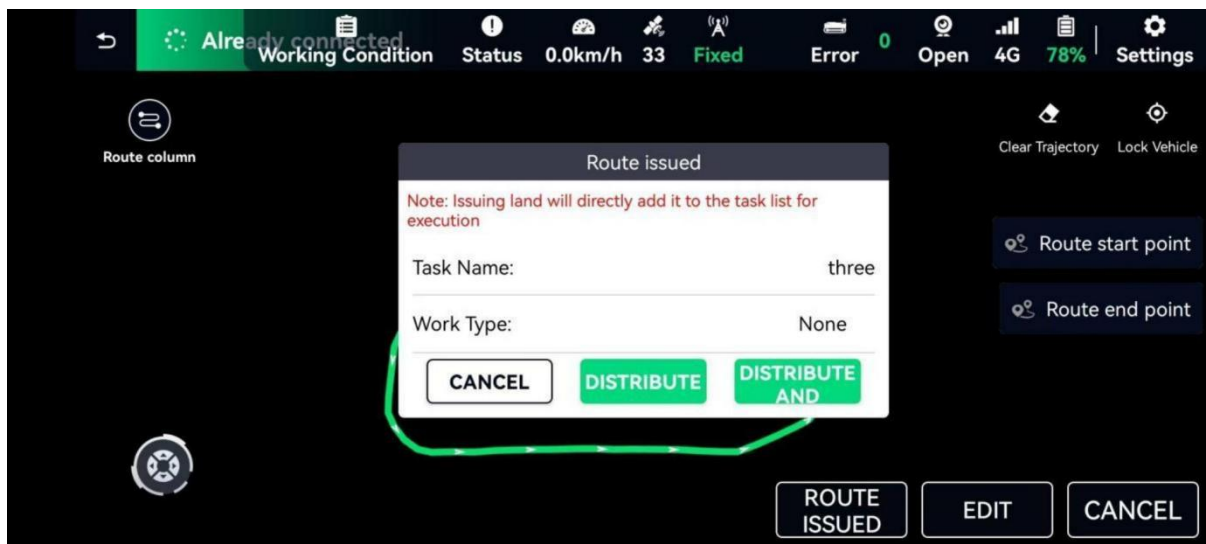
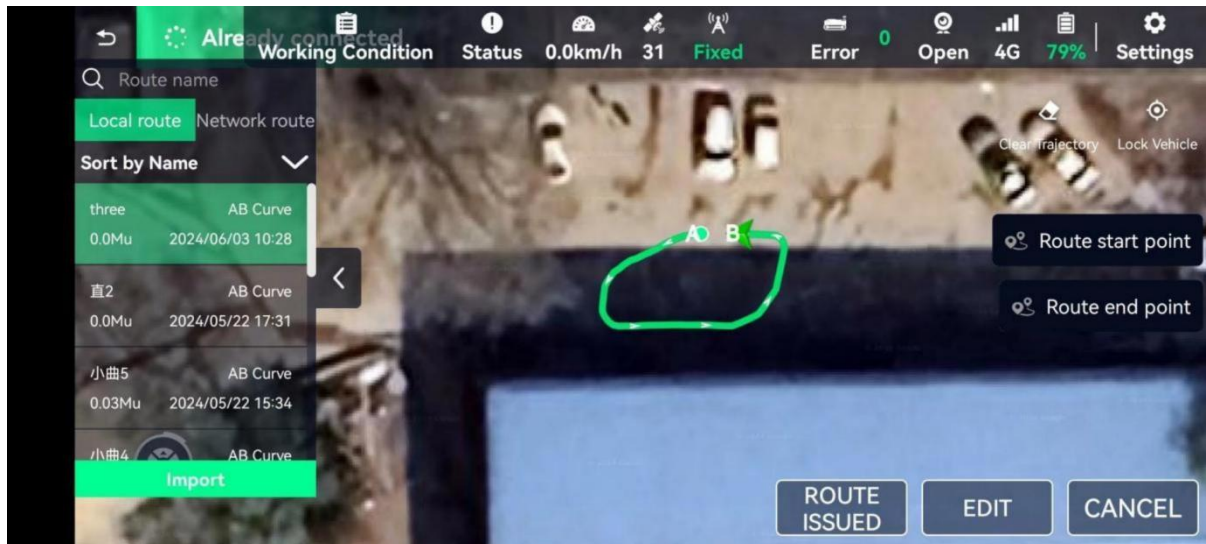

### 6.4.7 Safety parameters

1. Before performing the operation, you must first ensure that there are no obstacles in the path points, and the vehicle can pass smoothly.
2. Turn on the anti-collision bar switch and stop immediately upon collision.
3. Set the error parking alarm value and unit cm. Users can set it according to the actual situation on site.
4. Safety boundary. The default outermost point of the new path is the initial safety boundary. Users need to perform an outward expansion operation before performing the operation.

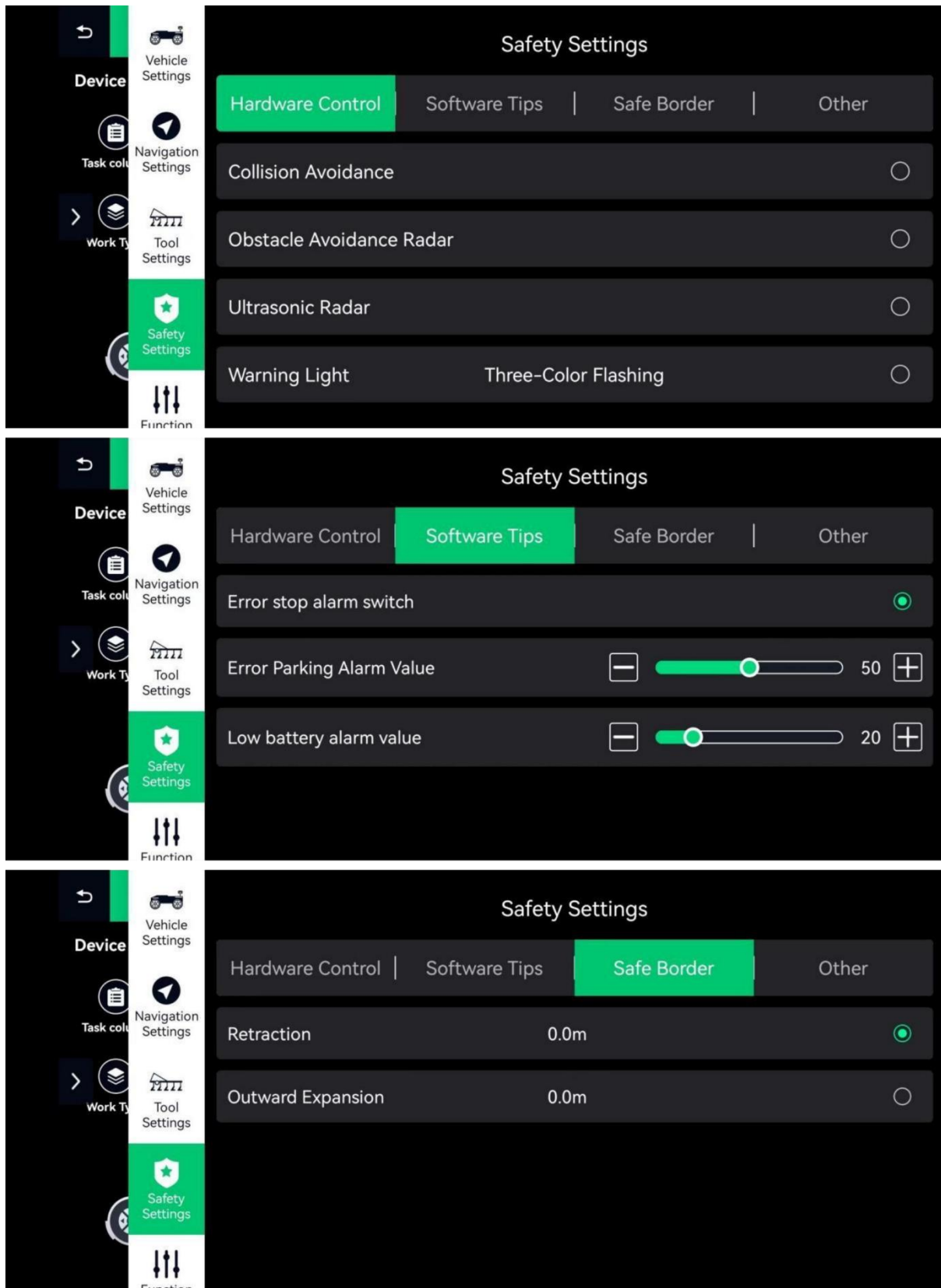

## 6.4.8 Execute the operation

1. Path imitation mode, you can directly "execute the operation"

2. A-B reciprocating mode, A-B U-turn mode, you can choose path planning, the setting column will pop up automatically, and the path will be generated according to the corresponding parameters after filling in the parameters

3. Plot planning mode, select the mode selection, the planning path selection column will pop up automatically, after confirming the mode, fill in the parameters and the path will be generated according to the corresponding parameters

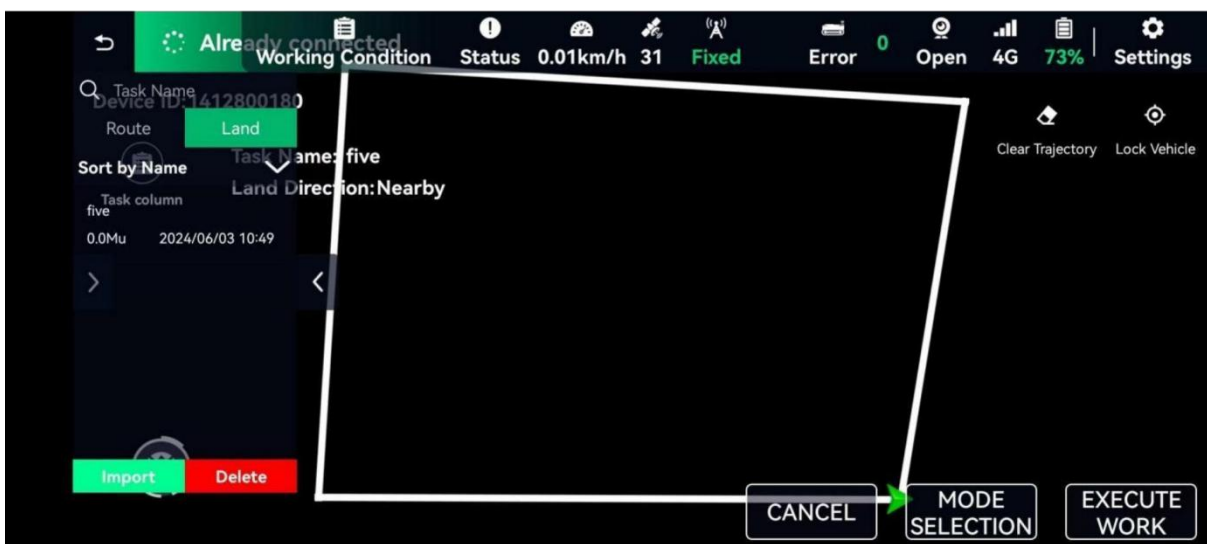
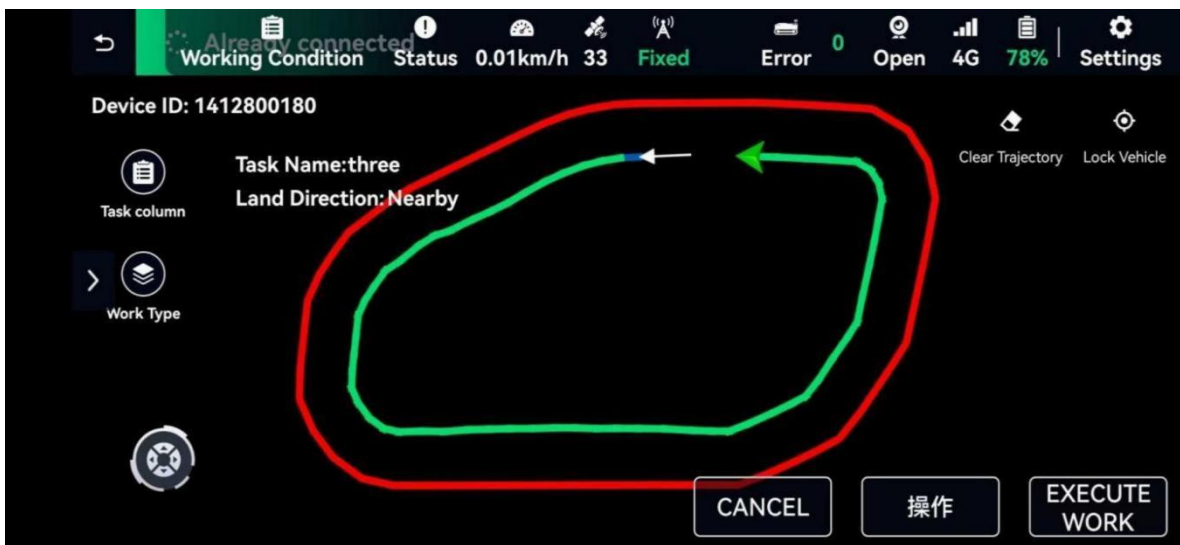

## 6.4.9 End of operation

1. After the vehicle completes the operation, the intelligence will end. If you need to change the operation path, you need to import a new operation path and start again.

2. If the operation is finished, you can switch the remote control mode to drive the vehicle back, exit the software, turn off the remote control, turn on the emergency stop switch, and turn off the power of the vehicle.

## 6.5 Introduction to software function parameters

### 6.5.1 Vehicle settings

1. Vehicle unit: The unit is m, and the default display is two decimal places
2. Main antenna height: The height value of the receiver from the ground, the receiver is measured in the middle
3. Antenna to front axle: The vertical distance from the center axis of the receiver to the center of the front wheel of the vehicle
4. Antenna to center axis: The vertical distance from the receiver to the center axis of the vehicle
5. Agricultural machinery wheelbase: The vertical distance between the center of the front and rear wheels of the vehicle
6. Front wheel track: The distance between the front wheels of the vehicle
7. Front wheel to the front of the vehicle: The vertical distance from the center of the front wheel to the front end of the vehicle (as a safety parameter during vehicle driving)



8. Rear wheel to the rear of the vehicle: The vertical distance from the center of the rear wheel to the rear end of the vehicle (as a safety parameter during vehicle driving)

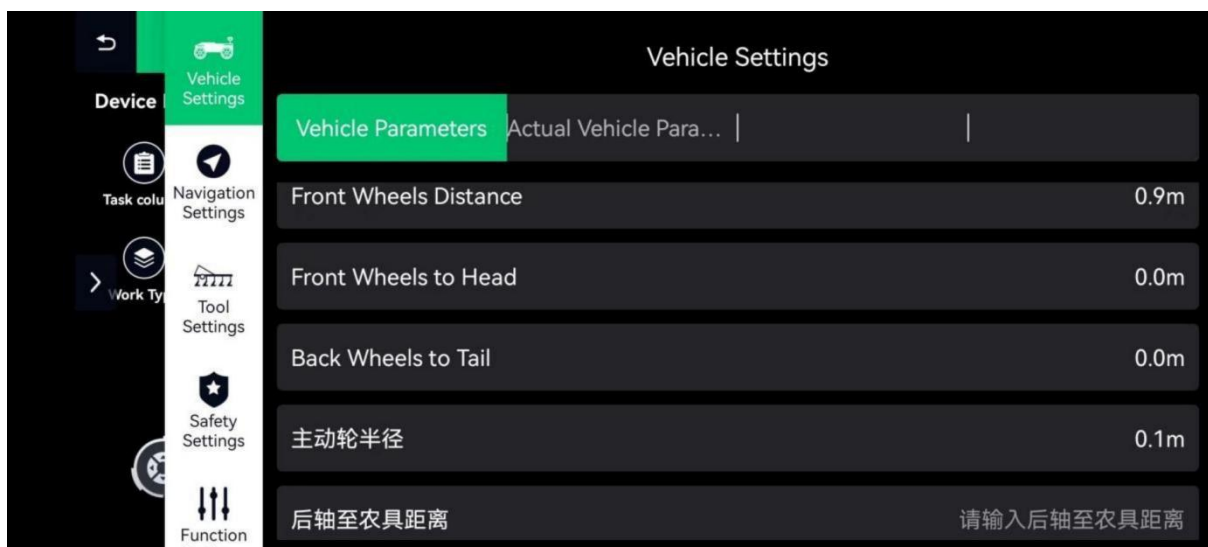
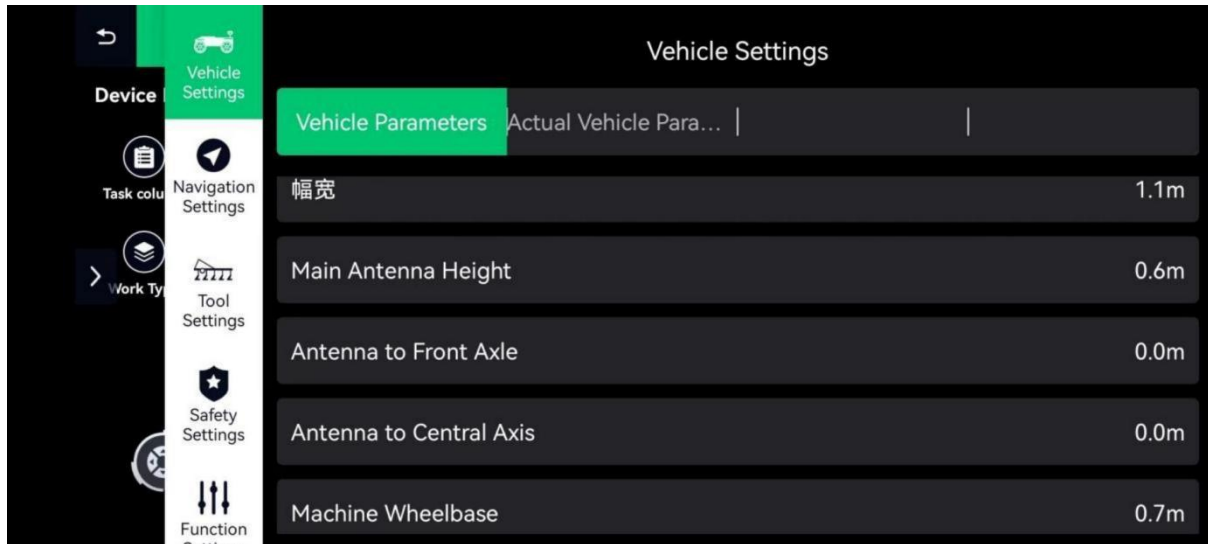

## 6.5.2 Straight-line debugging

1. Fixed forward vision: The larger the parameter, the smaller the vehicle steering fluctuation.

2. Center of the upper line: Divide the center line of the vehicle into 9 equal parts, and select the corresponding value according to the installation position of the receiver

3. Control mode: This model selects mode 2 by default.

4. Straight-line fit: Straight-line correction parameter, the larger the value, the greater the correction amplitude.

5. Amplitude, lateral deviation rate: Under different factors, the turning process makes the steering speed faster, which can reduce the phenomenon of winding out during the turning process, but it may make the jamming more obvious;

6. Frequency: Make the car turn faster. If the parameter is not too large, the jamming phenomenon will not be obvious.

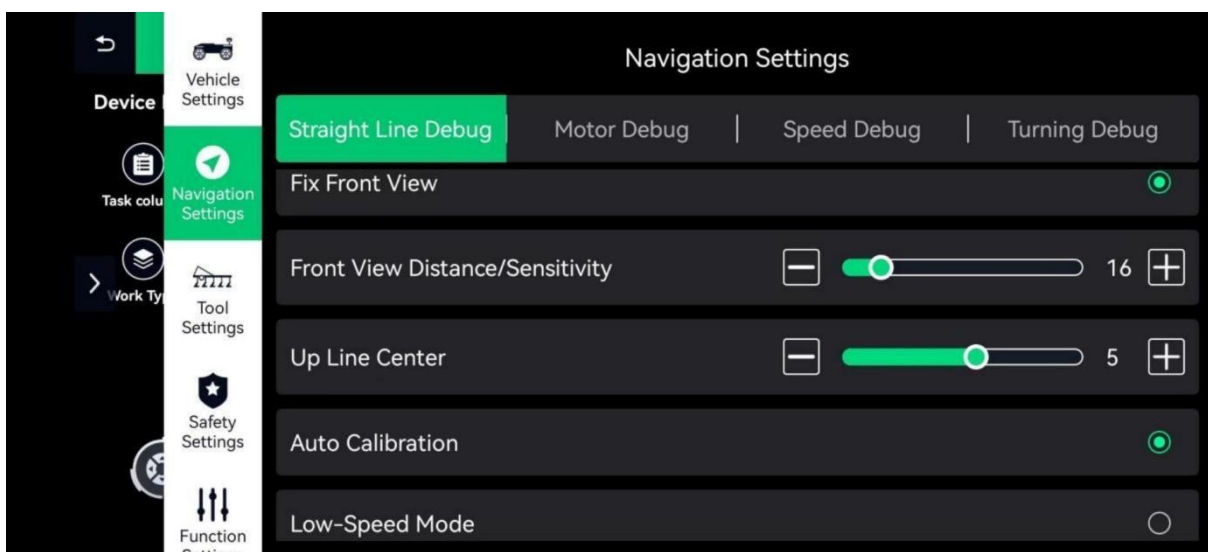

### 6.5.3 Speed Debugging

1. Working speed: the speed at which the vehicle is driving when performing intelligent operations;

2. Remote control speed: the speed at which the vehicle is controlled by the app/hardware remote control; (app manual remote control driving speed);

3. Turning speed: the speed at which the vehicle is turning; (applying U-turn straight line/circle);

4. Buffering speed: the speed at which the vehicle is performing error correction when performing intelligent operations; (applying the web-based

path operation mode);

5. Reversing speed: the speed at which the vehicle is reversing when performing intelligent operations: (applying the reciprocating operation mode);

6. Maximum speed: the fastest speed reached by the vehicle when it is moving;

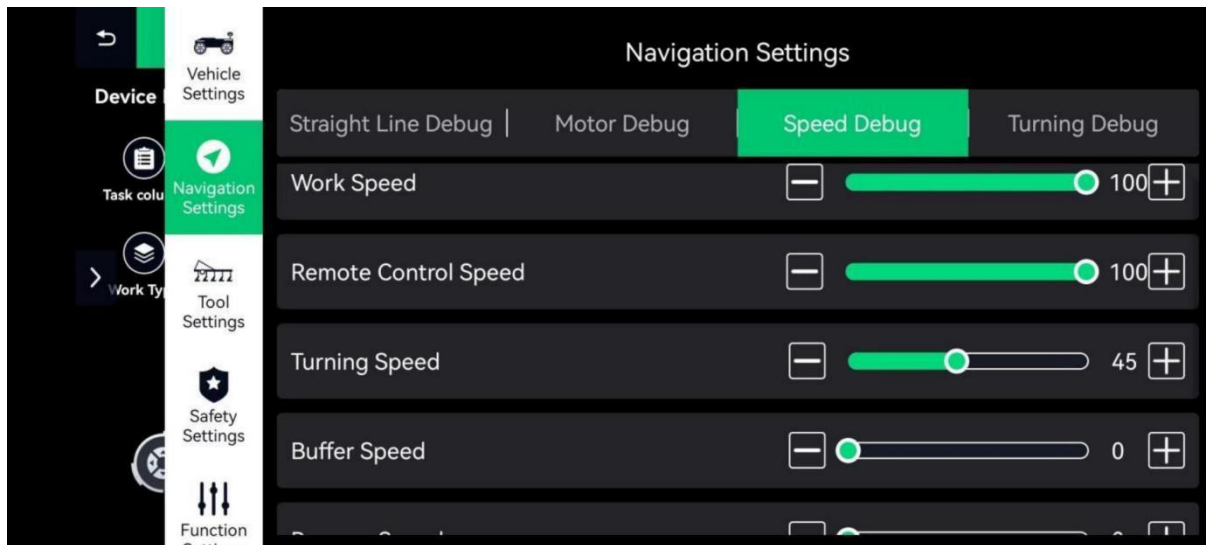

#### 6.5.4 Farm implement control

1. Spraying switch: When the sprayer is in remote control mode, the spray is controlled on one side;

2. Turning expansion area: When the spraying switch is turned on, the spray range on one side is covered;

3. Left pump control: When the sprayer is in remote control mode, the left pump is controlled;

4. Right pump control: When the sprayer is in remote control mode, the right pump is controlled;

5. Front pump control: When the sprayer is in remote control mode, the

front pump is controlled (for some models);

6. Fan control: When the sprayer is in remote control mode, the fan is controlled;

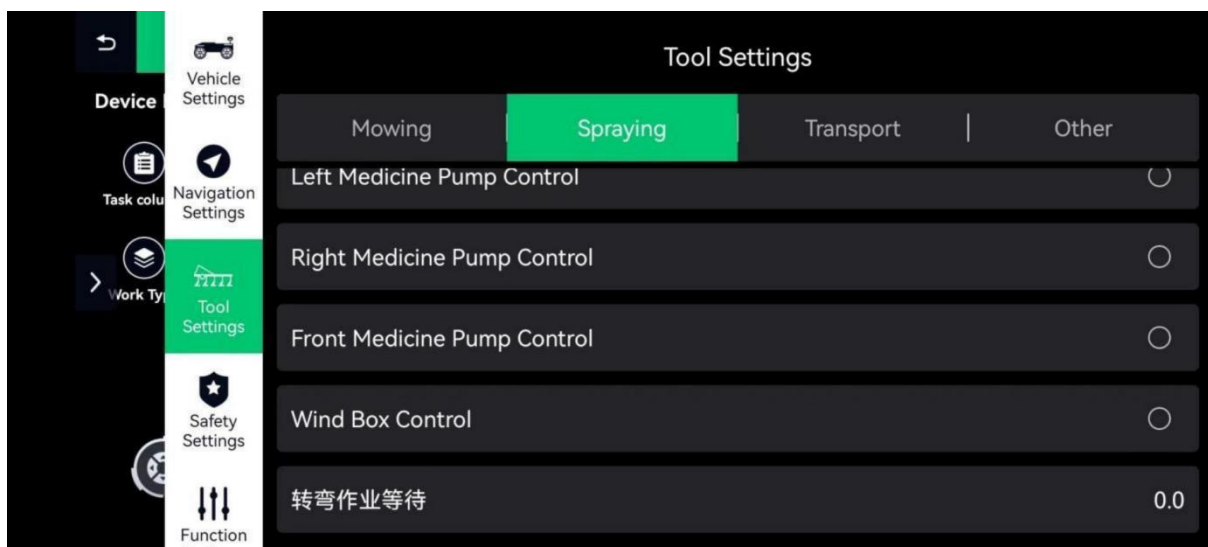
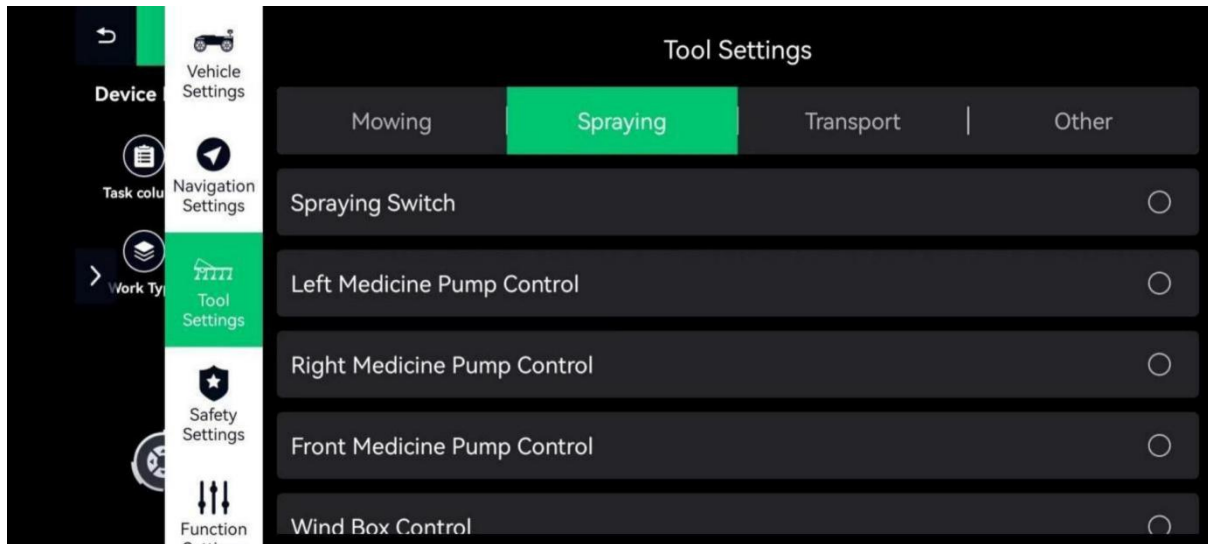

### 6.5.5 Safety settings

Hardware control

1. Anti-collision bar: anti-collision bar activation function button, stop immediately upon collision;

2. Millimeter wave radar: function switch activation button and safe deceleration distance to ensure smooth deceleration and stop;

3. Ultrasonic radar: function switch activation button and safe deceleration distance to ensure smooth deceleration and stop;

4. Warning light: warning light flashing switch, used for intelligent operation prompts or fault prompts;

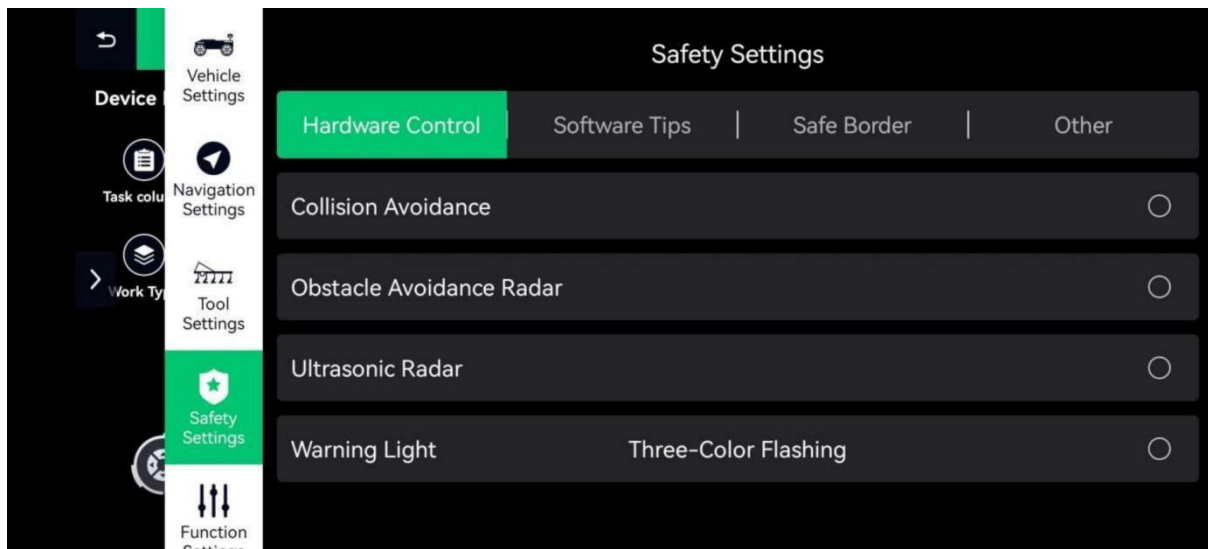

## 6.5.6 Software Tips

1. Error parking alarm value: vehicle driving error value setting, unit is cm, the default open setting range is 0-100, when the driving error is greater than the set value, the vehicle will stop immediately;

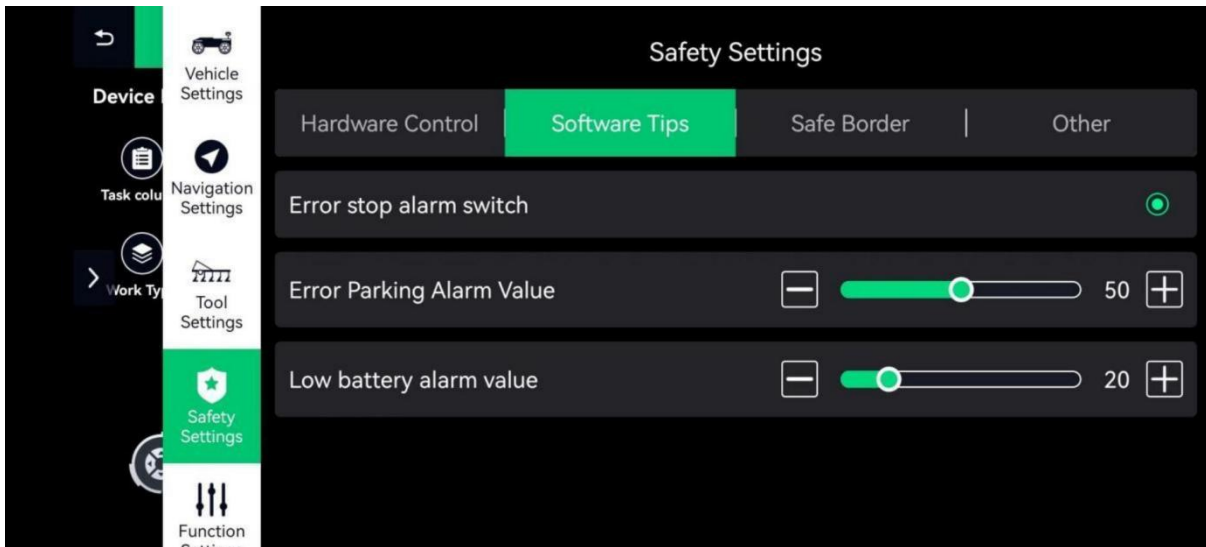

### 6.5.7 Safety Boundary

1. Safety Boundary: The simulated boundary is automatically established and is represented by a red frame, in meters. When the vehicle exceeds the boundary red line, the vehicle will stop immediately;

2. Inward contraction: A safe use method in which the safety boundary is retracted according to the plot information;

3. Outward expansion: Automatically generate a safety boundary based on the path boundary data;

### 6.5.8 General Settings

1. Language: Chinese standard, English, Russian, Japanese, Spanish, Korean added;
2. Length: cm, m, km, inch, foot, mile;
3. Area: mu, m<sup>2</sup>, square foot;
4. Capacity: ml, liter, gallon, quart, pint, ounce;

5. Speed: m/s, km/h, mile/hour;

## 7. Vehicle hardware parameters

<b>Rack System</b>	
Overall dimensions (length*width*height)	2200mm*1200mm*1000mm
Machine weight (unloaded)	450kg
<b>Power System</b>	
Power type	Hybrid power
Output voltage	48V
Generator rated power	9.5KW
Drive motor power	1KW
Fuel tank capacity	6L
Oil capacity	1.1L
Maximum fuel consumption	1.5L/h
Cylinder displacement	420cc
Fuel type	92# gasoline
Maximum travel speed	1.25m/s
Minimum turning radius	0m (turn in place)
Maximum climbing slope	50°
Maximum operating slope	30°
<b>Spraying system</b>	
Spraying method	Pressure delivery + air delivery
Rated power (water pump: high-pressure plunger pump)	1KW
Rated power (fan motor)	2kw

Blazer diameter	400mm
Operating box volume	300L
Nozzle type	XR4501S, XR9502S
Number of nozzles	6-8 pcs
Rated spraying rate & working pressure	8L/min (single pump) & 130kg/cm <sup>2</sup>
Atomized particle size	100μm-500μm
Spray width	6-8m
<b>remote control</b>	
Model	Mk15
Signal effective distance (no interference, no obstruction)	1000m

## 8.Solutions to common problems

### 8.1 Solutions to vehicle-side problems

#### 8.1.1 Permanent magnet motor cannot start

Permanent magnet motor cannot start			
Phenomenon	Problem Analysis		Methods
Permanent magnet motor cannot start	Circuit	Poor contact of the socket Cable line falling off Cable line aging	Re-insert and secure the cable.
	Abnormal	Motor stator and rotor friction or stuck; motor windings poor soldering, poor contact; motor turn-to-turn short circuit; motor insulation damage or aging	Reassemble and adjust the motor  Replace the motor stator Replace the motor stator Replace the motor stator
	Motor	No input voltage	Check input power line and



		No output voltage	replace controller
	Abnormal	Voltage is too low	Charge the battery first

### 8.1.2 Difficulty in starting the engine

Difficulty starting the engine				
Phenomenon	Problem Analysis		Method of exclusion	
Cylinder pressure normal	Fuel system abnormality	Oil line is blocked	No oil in the tank; The vent hole of the tank cap is blocked; The throttle switch is blocked; The main metering orifice is incorrectly adjusted or blocked; The needle valve or float is stuck	Refueling Unblocking Cleaning Re-adjusting, cleaning, blowing Repair or replacement
			The fuel is too dirty or deteriorated; There is water in the fuel; There is too much fuel in the cylinder; The fuel brand is wrong	Replace fuel and clean carburetor Replace fuel and clean carburetor Drain oil and wipe spark plugs Add specified brand of fuel
	Spark plug defective	Carbon deposits or dirty motors Insulator damage Severe motor ablation	Remove carbon deposits and dirt Replace spark plugs Replace spark plugs	

		Incorrect spark plug gap	Adjust gap
	No sparks	High voltage wire is damaged; Ignition coil is damaged; Magnetic field strength is insufficient	Replace high voltage wire Replace high voltage coil Magnetize or replace
Cylinder pressure is abnormal	The piston ring is worn beyond the limit or broken; The piston ring is glued; The spark plug has no gasket or is not tightened; The cylinder block and cylinder head joint surface leaks; the valve seal is not tight		Replace Remove carbon deposits Install gaskets or tighten Replace cylinder block Grind or replace

### 8.1.3 Abnormal output voltage

Output voltage is abnormal			
Phenomenon	Problem Analysis		Method of exclusion
Output voltage is abnormal	Abnormal engine speed	The speed regulating mechanism is not flexible; There is foreign object stuck on the speed regulating spring; The carburetor is damaged; The air filter is too dirty or damaged	Re-adjust the speed regulating mechanism; Remove foreign matter; Replace the carburetor; Clean or replace the air filter
	Permanent magnet motor	Motor friction Motor winding damage	Re-adjust the motor Replace the motor stator

	is abnormal	Motor magnet falling off or demagnetization	Replace the motor stator
	Controller abnormal	Controller rectifier system damaged	Replace the controller

### 8.1.4 Abnormal engine noise

Engine abnormal noise			
Phenomenon	Problem Analysis		Method of exclusion
Engine abnormal noise	Knocking sound	Piston and piston ring wear Connecting rod, piston pin and pin hole wear Crankshaft bearing wear Piston ring breakage	Replace worn parts Replace worn parts Replace or repair Replace piston rings
	Explosion with metallic sound	Too much carbon deposits in the combustion chamber, Too small gap between the spark plug and the motor, Serious oil leakage in the engine, Wrong fuel grade, Engine overheating	Remove carbon deposits Adjust motor clearance  Check carburetor  Replace fuel See overheating fault column
	Other abnormal noises	Improper adjustment of valve clearance; loose connection between flywheel and crankshaft	Re-adjust valve clearance and reinstall the connector Replace the connector and reinstall it

### 8.1.5 Engine overheating

Engine overheating		
Phenomenon	Problem Analysis	Method of exclusion

Engine overheating	Ignition timing is wrong; Engine oil is insufficient; Exhaust pipe is blocked; Air scoop is leaking  Debris blocking the air duct; Cooling fan damaged; Piston ring failure causing cylinder and  Crankcase cross-flow; Engine speed too high; Crankshaft bearing burnt out	Replace the ignition coil; Add enough engine oil; Clean the exhaust pipe; Repair the damage  Clean the heat sink Reinstall it Replace worn parts  Inspect the speed control system or replace the speed control gear Replace or repair
--------------------	--	---

### 8.1.6 Sudden engine shutdown

The engine suddenly shuts down			
Phenomenon	Problem Analysis		Method of exclusion
The engine suddenly shuts down	Fuel System	Fuel exhausted; Clogged carburetor; Carburetor float leaking; Needle valve stuck	Add fuel, dredge  Check oil line, dredge Repair float Repair needle valve
	Ignition system	Spark plug breakdown, carbon deposit short circuit Spark plug motor fall off High voltage wire fall off Ignition coil breakdown	Replace spark plugs Replace spark plugs Repair or replace Replace
	Other	Severe cylinder pulling or valve falling off;  Flame-out wire falling off and grounding	Repair or replace damaged parts and reconnect the flame out wire

<b>8.1.7 Insufficient engine power Insufficient engine power</b>			
Phenomenon	Problem Analysis		Method of exclusion
Insufficient engine power	Ignition system	Low ignition energy Incorrect ignition timing	Replace the igniter or flywheel Replace the igniter
	Fuel System	Air mixed in the oil circuit; Carburetor clogged or damaged; Oil switch clogged Burning room charcoal accumulation Air filter clogged	Remove air; Clean or replace carburetor; Clean or replace damaged parts Remove carbon deposits and clean or Replace the filter element
	Air Intake System	Intake system leaks or clogged; The air valve is not open; The piston, cylinder, and piston ring are worn.	Repair or replace Open damper Replace
	Poor compression	Air leakage at the joint surface between cylinder block and cylinder head Incorrect valve clearance Poor valve sealing	Replace cylinder gasket Re-adjust Grind or replace

## 8.2 Intelligent system problems and solutions

1. Does the receiver indicator light off after the vehicle is powered on?

Solution: Check whether the emergency stop is turned on or whether the wiring is loose.

2. Is the heading abnormal during APP remote control or intelligent

operation?

Solution: It is recommended to restart the vehicle and re-initialize it. When the operation site is blocked, the single antenna mode is preferred.

3. The base station cannot be fixed normally?

Solution: Check the surrounding environment and drive the vehicle to a relatively open place to prevent signal obstruction.

4. Does the nozzle of some drug pumps not discharge medicine or the amount of medicine is small?

Solution: There may be a blockage. It is recommended to unscrew the nozzle to clear it.

5. Does the vehicle suddenly have a poor driving trajectory during intelligent driving?

Solution: Check whether the vehicle receiver installation is shaking.

6. The base station status is floating/pseudo-range cannot enter intelligent?

Solution: The current position may be severely blocked. The remote control vehicle moves to a fixed solution to start the operation.

7. The water output is small or the atomization effect is poor during intelligent driving.

Solution: The range extender is not fully burned. It is recommended to end the intelligent operation first and then enter the intelligent operation again after the app is ignited.

## **9. Machine maintenance and repair**

During the operation of the machine, due to the change of operation, friction and wear and load, the connection bolts will inevitably loosen and the parts will wear, which will destroy the normal state of the system, causing abnormal clearance, gasoline engine power reduction, increased fuel consumption, various components out of adjustment, and increased machine failures, which will seriously affect the normal use of the machine. In order to reduce the occurrence of the above situation, it is necessary to strictly and regularly carry out maintenance work with "prevention as the main" to keep the machine in good technical condition and extend its service life.

### **9.1 Technical maintenance**

#### **9.1.1 Maintenance per work (before and after each work).**

1. Listen and observe whether there are any abnormal phenomena in each part (such as abnormal noise, overheating and loose screws, etc.).
2. Check whether there is oil leakage in the gasoline engine and transmission box.
3. Check whether the oil level of the gasoline engine and transmission box is between the upper and lower limits of the oil dipstick.
4. Remove dirt and oil stains on the whole machine and accessories in time.

#### **9.1.2 First-level maintenance (every 150 hours of work).**

1. Carry out all the contents of maintenance per work.
2. Clean the transmission case and change the engine oil.

### 9.1.3 Secondary maintenance (every 800 working hours).

1. Perform all the maintenance contents every 150 working hours.
2. Check all gears and bearings. If they are severely worn, please replace them with new ones.
3. If the rest of the machine parts or connecting bolts and nozzles are damaged, please replace them with new ones.

## 9.2 Daily maintenance calibration

### 9.2.1 Normal maintenance procedures

Use authentic original series engine parts or their equivalents. If poor quality substitutes are used, the engine will be damaged. If you want the engine to maintain good performance, you must check and adjust it regularly. Regular maintenance also guarantees a long service life. The required maintenance intervals and maintenance items are described in the following table:

		Daily use	20hours	50hours	100hours	300hours
Engine	Check oil level	✓				
Lubricating oil	Replace		✓		✓	
Reduction gear Lubricating oil	Check oil level					
	Replace		✓			✓
Air filter	Check/clean	✓				
Integrator	Cleaning				✓	
Spark	Check/clean				✓	



plugs						
Spark arrester	Clean				✓	
Fuel tank and filter	Clean					✓
Valve	Check-adjust					
Fuel line	Check					✓

### 9.2.2 Check the engine oil

Note: Before using the engine, add lubricating oil to the normal oil level according to the engine instructions, and check every 4 hours. If the engine started when the oil level is lower than normal, it will cause serious damage to the engine.

1. Put the engine in a horizontal position.
2. Unscrew the engine oil dipstick and wipe it clean.
3. Insert the oil dipstick into the filling hole (no need to unscrew).
4. Take out the dipstick and check the oil level. The oil level is normal if it is within the 1/2 range of the dipstick grid.

### 9.2.3 Gasoline engine maintenance

1. Turn off the engine before performing any maintenance.
2. In case the engine started accidentally, please turn the remote control switch to OFF.
3. Check all fasteners of the fuselage, and no looseness is allowed;
4. Check whether the control circuitjoints of the engine and the whole vehicle are in good connect, and whether the motor and the controller are damp;
5. Check whether there is oil leakage in the lower part of the engine, whether there is oil leakage in the fuel channel, and whether there is enough fuel in the fuel tank;

6. Check whether the oil is within the specified level. The specific operation is as follows: Remove the oil dipstick from the oil filling port and wipe it clean. Insert the oil dipstick and check the oil level without tightening it. If the oil level is too low, add the recommended oil to the upper limit of the oil level. After adding the oil, remember to install and tighten the oil dipstick.

#### **9.2.4 Spark plug replacement**

1. Be careful not to use spark plugs that do not meet the thermal value range.
2. Note that in order to ensure the normal operation of the engine, the gap of the spark plug must be moderate and free of carbon deposits.

#### **9.2.5 Maintenance of the whole machine**

When the machine needs to be stored for a long time, in order to prevent rust, the following measures should be taken:

1. Seal the gasoline engine according to the requirements of the gasoline engine manual.
2. Clean the dust and dirt on the surface.
3. Release the lubricating oil in the transmission box and inject new oil.
4. Apply anti-rust oil to the unpainted areas of non-aluminum alloy surfaces.
5. Store the machine in a ventilated, dry and safe place indoors.
6. Properly keep the tools, product certificates and manuals.

#### **9.2.6 Maintenance of the spray nozzle**

1. Regular cleaning: After use, promptly remove the residual liquid, debris, etc. on the surface of the nozzle. Rinse with clean water or wipe with a soft cloth.
2. Check blockage: Frequently observe the spray state of the nozzle. If uneven spray or signs of blockage are found, clear the blockage in time. You can use a fine needle and other tools to carefully clear it.
3. Prevent collision: During operation and storage, avoid collision of the nozzle to avoid damage to the nozzle structure.

4. Check the seal: Ensure that the seal between the nozzle and the connecting parts is good to prevent liquid leakage.

5. Test performance: Perform spray tests regularly to ensure that the spray effect of the nozzle meets the requirements.

6. Proper storage: When not in use, store the nozzle properly to avoid dust, debris, etc.

7. Replace worn parts: Pay attention to the wear of the nozzle, and replace severely worn parts in time if necessary.

### **9.2.7 Filter maintenance**

Note: Too much dust or moisture in the air filter element will prevent air from entering the carburetor, causing the engine to smoke and damage the engine. The air filter should be maintained regularly. If the engine is running in a very dusty place, it must be cleaned every 2 hours.

1. Remove the butterfly screw cap and the air filter cover, and take out the filter element.

2. Blow off the dust on the filter element with compressed air.

3. Reinstall the air filter and the air filter cover.

### **9.2.8 Fan maintenance**

1. Cleaning: Regularly clean the dust, debris and liquid residue on the surface of the fan, and wipe it with a soft cloth.

2. Check the blades: Check whether the blades are damaged, deformed or loose, and repair or replace them in time if there are any problems.

3. Tighten the connection: Ensure that the connection parts between the fan and the vehicle body are tight and there is no looseness.

4. Operation inspection: Start the fan frequently to check whether it runs smoothly and whether there is any abnormal noise or vibration.

5. Motor maintenance: Pay attention to the heat dissipation and maintenance of the fan motor, and check whether the circuit is normal.

6. Protective measures: Protect the fan well to avoid damage such as impact from external objects.

7. Regularly test performance: Test the fan's air volume, air pressure and other performance indicators to ensure that its working capacity meets the requirements.

8. Waterproof and moisture-proof: Pay attention to the storage environment to prevent the fan from being damp, rusted or soaked in water.

### 9.2.9 Analysis of common faults of high-pressure water pumps

Analysis of common faults of high pressure water pump				
Fault description	cause of issue		Method of exclusion	Accompanying phenomenon
Low pressure	Inadequate water supply	Insufficient water supply	Increase water delivery	
		Unclean water causes filter clogging	Cleaning the filter	
	Pressure regulating valve damaged	The pressure regulating valve or the valve surface of the pressure regulating valve seat is worn.	replace	
		The O-ring of the pressure regulating valve is damaged	replace	
		Pressure regulating valve stuck	replace	Pressure regulation without load unloading
	Damage to water inlet and outlet valves	The O-ring of the water inlet and outlet valve is damaged	replace	Unstable pressure; severe vibration of the water outlet pipe or no water
		The inlet and outlet valve covers are deformed by pressure	replace	
		Wear of water inlet and outlet valve seats	replace	
		The valve plate is firmly attached to the valve base or is supported by foreign matter.	Disconnect cleaning	
		The water inlet valve spring is	replace	

		deformed or damaged		
Water seal leakage		Normal wear and tear	replace	
		Wear caused by poor water quality	replace	
		High operating temperature due to lack of water causes wear and tear of the main water seal	replace	
		The inside and outside of the auxiliary water seal are damaged	replace	Water leakage at the connection between the box and the pump body
	Nozzle hole wear and tear		Replace the nozzle	
Intake pipe leaking		Water inlet pipe is damaged	Replace the water inlet pipe	Abnormal vibration of high pressure pipe
		The filter is not tightened	Tighten it again	
		Leakage at water pipejoint	Reinforce it with rolled strips	
Water outlet pipe leaking		Water leakage caused by poor sealing at the outlet pipejoint	Seal it with raw tape	
		Water leakage caused by wear of outlet pipe	Replace the water outlet pipe	
The box is hot.	Too much/too little/dirty oil.		Add oil to the 1/2 oil window/replace the oil.	Lack of oil will cause the connecting rod to break and the box to be damaged.
	Bearing wear or corrosion		Replace the bearings	
	Pressure exceeds rated value		Adjust the pressure to the rated value	
	Eccentric shaft bearing wear		Replace the eccentric shaft	
	Wrong brand of engine oil selected		Choose the correct lubricant	

Too high pressure	The spray hole or water outlet is clogged	Clear the nozzle or outlet pipe	
	The nozzle hole is too small	Choose the correct spray hole	

## 10. List information

### 10.1 Accessories list

No	Part	Model	Parameter Unit
The main components			
1	Chassis controller	2E-4880	Piece
2	Tracks	180*72*50	Strip
3	Drive motor	48V-1200w	Piece
4	Range extender	1. Fuel tank capacity: 6L 2. Engine oil capacity: 1.1L 3. Maximum fuel consumption: 3L/h 4. Cylinder displacement: 420cc 5. Fuel type: 92# gasoline	Set
5	Range extender controller	9.5kw	Piece
6	Remote control	MK15	Piece
7	Lead-acid battery	1. Brand: Tianneng 2. Category: Battery 3. Battery model: 48v32ah	Set

		4. Battery voltage: 48V  5. Battery capacity: 10-19Ah  6. Weight: 9.3kg	
8	Road wheel assembly	Thickened 150mm	Set
9	Water pump motor	48V-1000w	
10	Water pump head	2800r	each
11	Water pump crankcase	2800r	each
12	Water pump control	48V-1000w	each
13	Night light	High voltage 12 lamp beads	each
14	Fan motor	48V-2000w	each
15	Fan controller	48V-2000w	each
16	Fan blades	400mm	each
17	Air filter assembly	192F range extender	each
18	Carburetor	190F does not include dual stepper motors	each
19	Stepper motor	12v	each

## 10.2 Wearing parts

1	Filter	100 mesh	pcs
2	Tray	135mm	pcs
3	Nozzle	High pressure 4501	pcs
4	Dust cover	TY-150	pcs
5	Fan blade guard	420mm	sets

## 11. Three Guarantees Agreement

Because the intelligent robot control system equipment serves agriculture, which has strong seasonality, in order to better serve the majority of users, in accordance with the "Contract Law of the People's Republic of China" and relevant laws and regulations, Shanghai Mini Deer Robot Co., Ltd. makes the following supplementary explanations on the after-sales service of intelligent robot control system products.

Party A: Shanghai Mini Deer Robot Co., Ltd.

Party B: Customer

### Service Content

After you (hereinafter referred to as Party B) purchase the intelligent robot control system equipment of Shanghai Mini Deer Robot Co., Ltd. (hereinafter referred to as Party A), our company's technical personnel will provide you with product installation and debugging services; according to Party B's requirements, Party A is obliged to provide technical support and training in product use and other aspects; Party A is obliged to ensure the provision of repair parts and equipment maintenance services.

### Service Details

1. Party A provides one-year warranty service for the products sold (excluding wearing parts).

2. The core components of the intelligent robot control system are



controllers, receivers, wiring harnesses and app software.

3. The warranty period starts from the date of product installation. After the intelligent robot system exceeds the warranty period, Party A will consistently provide paid non-warranty after-sales service.

4. During the warranty period, the following situations are not covered by the warranty.

① Damage to components caused by unstable voltage

② Damage to the machine caused by not using it in accordance with normal regulations;

③ The user fails to follow the installation and operating instructions provided by Party A, which causing damage to the machine.

④ Failure or damage caused by force majeure such as earthquakes;

⑤ The user's unauthorized modification of the product causes damage to the product.

⑥ The user unauthorizedly entrusts non-Party A authorized personnel to repair the machine;

5. When the product is not covered by the warranty, you shall bear the transportation, delivery and handling costs incurred in the process of sending the product or accessories to Party A for repair and testing; Party A shall bear the costs incurred when sending the product or accessories back to you.

6. Matters not covered in this clause shall be handled in accordance with the provisions of the National Three Guarantees Law.

## Service Process

1. If the system fails, the user can directly call the installation technician or Party A's after-sales service hotline: 400-1698-003.

2. The operator will help Party B transfer to Party A's technical supervisor or technical support personnel.

3. The technical supervisor can communicate with the user by phone according to the specific situation. If a technical engineer is required to go to the site, the technical engineer can be arranged to provide services to the user on site.

4. After the technical engineer solves the problem, he should make a good service record, fill out the maintenance record sheet, and ask the user to sign and confirm. The service receipt sheet shall be in triplicate, one for the user, one for the technical engineer, and one for the company.

5. After the technical staff completes the service work, Party A shall follow up the service of Party B to confirm whether the after-sales service is in place and record it in the service file.

### 6. Principles of after-sales service charging and user payment method

① Provide after-sales service in accordance with national laws and regulations and the terms listed in the sales contract.

② During the warranty period, Party A provides free after-sales services such as debugging and maintenance.

③ After the after-sales service work is completed, the user can pay cash

directly to the technical engineer. However, the amount and details should be indicated on the maintenance record sheet.

④ After the after-sales service work is completed, the user shall remit the money to the bank account provided by Party A by wire transfer within three days. The handling fee generated by the wire transfer shall be borne by the user. If the user still fails to pay the after-sales service fee to Party A seven days after the completion of the after-sales service work, Party A will charge a late payment fee, the amount of which is 1% of the total after-sales service fee per day.

⑤ If a user defaults on the after-sales service fee for two consecutive times without reason, Party A has the right to suspend the paid after-sales service to the user.

## **12. Disclaimer**

Dear user:

Thank you for using our company's self-propelled intelligent sprayer. During your use of this product, please read carefully and understand the following disclaimer terms.

1. The self-propelled intelligent sprayer is developed and manufactured based on advanced technology, but the technology has certain limitations. In some special environments or unforeseen circumstances, it may operate abnormally or fail to achieve the expected results. The company does not assume the corresponding responsibility for this.

2. The company is not responsible for any loss, damage or accident caused by the user's failure to use this equipment correctly in accordance with the operating manual, including but not limited to the impact on personnel, property, crops, etc.

3. External factors such as bad weather, complex terrain, electromagnetic interference, etc. may affect the performance of this equipment. The company does not assume responsibility for the problems caused by this.

4. The user shall bear the legal consequences arising from violation of relevant laws and regulations during the use of this equipment.

5. The company is committed to continuously improving product performance and quality, but cannot guarantee that the product is absolutely fault-free at any time. For product quality problems that are handled in accordance with relevant regulations during the warranty period, the company does not assume unlimited liability for exceeding the warranty period.

6. In any case, the company shall not be liable for indirect, incidental, special or consequential losses or damages.

Please fully understand and accept the above disclaimer terms before using the smart driving pesticide sprayer. If you have any questions or need further information, please feel free to contact u

**FCC STATEMENT:**

This device complies with part 15 of the FCC Rules. Operation is subject to the following two conditions:

(1) This device may not cause harmful interference, and (2) this device must accept any interference

received, including interference that may cause undesired operation.

Any Changes or modifications not expressly approved by the party responsible for compliance could

void the user's authority to operate the equipment.

Note: This equipment has been tested and found to comply with the limits for a Class B digital device,

pursuant to part 15 of the FCC Rules. These limits are designed to provide reasonable protection

against harmful interference in a residential installation. This equipment generates uses and can radiate

radio frequency energy and, if not installed and used in accordance with the instructions, may cause

harmful interference to radio communications. However, there is no guarantee that interference will not

occur in a particular installation. If this equipment does cause harmful interference to radio or television

reception, which can be determined by turning the equipment off and on, the user is encouraged to try to

correct the interference by one or more of the following measures:

-Reorient or relocate the receiving antenna.

-Increase the separation between the equipment and receiver.

-Connect the equipment into an outlet on a circuit different from that to which the receiver is connected.

-Consult the dealer or an experienced radio/TV technician for help.

This equipment complies with FCC radiation exposure limits set forth for an uncontrolled environment.

This equipment should be installed and operated with minimum distance 20cm between the radiator & your body



上海智小鹿机器人有限公司  
Shanghai L - deer Robot limited

**All rights reserved;**

**Those responsible for unauthorized reproduction will be prosecuted.**