



A Test Lab Techno Corp.

Changan Lab : No. 140-1, Changan Street, Bade District, Taoyuan City 33465, Taiwan (R.O.C).

Tel : 886-3-271-0188 / Fax : 886-3-271-0190



SAR EVALUATION REPORT

Test Report No.	: 1810FS12-02
Applicant	: OneLife Technologies Corp
Product Type	: OnePulse
Trade Name	: oneLife
Model Number	: R03
Date of Received	: Jun. 20, 2018
Test Period	: Sep. 14 ~ Oct. 24, 2018
Date of Issued	: Nov. 29, 2018
Test Environment	: Ambient Temperature : $22 \pm 2^{\circ} \text{C}$ Relative Humidity : 40 - 70 %
Standard	: ANSI/IEEE C95.1-1992 / IEEE Std. 1528-2013 47 CFR Part §2.1093 KDB 865664 D01 v01r04 / KDB 865664 D02 v01r02 KDB 447498 D01 v06 / KDB 941225 D05 v02r05 KDB 248227 D01 v02r02
Test Lab Location	: Chang-an Lab
Test Firm MRA designation number	: TW0010



1. A Test Lab Techno Corp. tested the above equipment in accordance with the requirements set forth in the above standards. All indications of Pass/Fail in this report are opinions expressed by A Test Lab Techno Corp. based on interpretations and/or observations of test results. The test results show that the equipment tested is capable of demonstrating compliance with the requirements as documented in this report.
2. This report shall not be reproduced except in full, without the written approval of A Test Lab Techno Corp. This document may be altered or revised by A Test Lab Techno Corp. personnel only, and shall be noted in the revision section of the document. The client should not use it to claim product endorsement by TAF, or any government agencies. The test results in the report only apply to the tested sample.

Approved By : Edison Hu
(Edison Hu)

Tested By : Kris Pan
(Kris Pan)



Contents

1. Summary of Maximum Reported SAR Value.....	4
2. Description of Equipment under Test (EUT)	5
3. Introduction.....	6
3.1 SAR Definition	6
4. SAR Measurement Setup.....	7
4.1 DASY E-Field Probe System.....	8
4.1.1 E-Field Probe Specification	8
4.1.2 E-Field Probe Calibration process.....	9
4.2 Data Acquisition Electronic (DAE) System	10
4.3 Robot.....	10
4.4 Measurement Server.....	10
4.5 Device Holder.....	11
4.6 Oval Flat Phantom - ELI 4.0.....	11
4.7 Data Storage and Evaluation.....	12
4.7.1 Data Storage	12
4.7.2 Data Evaluation	12
5. Tissue Simulating Liquids	14
5.1 Ingredients.....	15
5.2 Recipes	15
5.3 Liquid Depth	16
6. SAR Testing with RF Transmitters	17
6.1 SAR Testing with LTE-Cat M1 Transmitters	17
6.2 LTE Frequency range and channel bandwidth	19
6.2.1 Maximum power reduction (MPR).....	20
6.3 Power reduction	20
6.4 SAR Testing with 802.11 Transmitters.....	21
6.5 Conducted Power.....	22
6.6 Antenna location.....	25
6.7 Stand-alone SAR Evaluate.....	26
6.8 Simultaneous Transmitting Evaluate	28
6.8.1 Sum of 1-g SAR of all simultaneously transmitting.....	29
6.8.2 SAR to peak location separation ratio (SPLSR)	30
6.9 SAR test reduction according to KDB.....	30
7. System Verification and Validation.....	31
7.1 Symmetric Dipoles for System Verification.....	31
7.2 Liquid Parameters	31
7.3 Verification Summary	33
7.4 Validation Summary.....	34
8. Test Equipment List	35
9. Measurement Uncertainty.....	36
10. Measurement Procedure	39
10.1 Spatial Peak SAR Evaluation	39
10.2 Area & Zoom Scan Procedures.....	40
10.3 Volume Scan Procedures.....	40
10.4 SAR Averaged Methods	40
10.5 Power Drift Monitoring.....	40



11. SAR Test Results Summary.....	41
11.1 Head SAR Measurement	41
11.2 Body SAR Measurement.....	41
11.3 Hot-spot mode SAR Measurement.....	41
11.4 Extremity SAR Measurement	42
11.5 SAR Variability Measurement.....	43
11.6 Std. C95.1-1992 RF Exposure Limit.....	43
12. References	44
Appendix A - System Performance Check.....	45
Appendix B -SAR Measurement Data.....	49
Appendix C -Calibration	63



1. Summary of Maximum Reported SAR Value

Equipment Class	Mode	Highest Reported	
		Body standalone SAR _{1g} (W/kg)	Extremity standalone SAR _{10g} (W/kg)
PCT	Band 2 (QPSK)	0.504	0.878
	Band 4 (QPSK)	0.418	0.611
	Band 12 (QPSK)	0.069	0.121
DTS	WLAN 2.4 GHz	0.159	0.308
Highest Transmission SAR		Body standalone SAR _{1g} (W/kg)	Extremity standalone SAR _{10g} (W/kg)
		0.504	0.878

- NOTE: 1. The SAR limit (Head & Body: SAR 1 g 1.6 W/kg ;Extremity SAR 10 g 4W/kg) for general population / uncontrolled exposure is specified in FCC 47 CFR part 2 (2.1093) and ANSI/IEEE C95.1-1992.
2. EUT cellular functionality is enabled by LTE Cat M1 radio module.



2. Description of Equipment under Test (EUT)

Applicant	OneLife Technologies Corp 5005 Newport Drive Suite 101 Rolling Meadows, IL 60008 United States		
Manufacture	Shenzhen Yinuo Technologies,Ltd. Rm A605, Building AD, Gao Xin Qi Science Industry Park2 Liu Xian Yi Lu Bao An District, Shenzhen		
Product Type	OnePulse		
Trade Name	oneLife		
Model Number	R03		
IMEI No.	015058000227190 (for Cat M1) 015058000227117 (for WLAN) 015058000227232 (for Bluetooth)		
FCC ID	2AQKZR03		
RF Function	Operate Bands		
	Cat M1	Operate Frequency (MHz)	
		Band 2 (BW 1.4 MHz)	1850 - 1910
		Band 4 (BW 1.4 MHz)	1710 - 1755
	Band 12 (BW 1.4 MHz)	699 - 716	
IEEE 802.11b / 802.11g / 802.11n 2.4 GHz 20 MHz		2412 - 2462	
Bluetooth LE		2402 - 2480	
Antenna Type	Internal antenna		
Battery Option	Standard		
	Manufacturer: YJ POWER GROUP LIMITED Model: YJ 452328 Spec: DC 3.8 V / 300 mAh		
Device Category	Portable Device		
Application Type	Certification		

Note:The above EUT's information was declared by manufacturer. Please refer to the specifications or user's manual for more detailed description.

3. Introduction

The A Test Lab Techno Corp. has performed measurements of the maximum potential exposure to the user of **OneLife Technologies Corp Trade Name : oneLife Model(s) : R03**. The test procedures, as described in American National Standards, Institute C95.1-1999 [1] were employed and they specify the maximum exposure limit of 1.6 mW/g as averaged over any 1 gram of tissue for portable devices being used within 20 cm between user and EUT in the uncontrolled environment. A description of the product and operating configuration, detailed summary of the test results, methodology and procedures used in the equipment used are included within this test report.

3.1 SAR Definition

Specific Absorption Rate (SAR) is defined as the time derivative (rate) of the incremental energy (dw) absorbed by (dissipated in) an incremental mass (dm) contained in a volume element (dv) of a given density (ρ). It is also defined as the rate of RF energy absorption per unit mass at a point in an absorbing body (see Figure 2).

$$\text{SAR} = \frac{d}{dt} \left(\frac{dw}{dm} \right) = \frac{d}{dt} \left(\frac{dw}{\rho dv} \right)$$

Figure 2. SAR Mathematical Equation

SAR is expressed in units of Watts per kilogram (W/kg)

SAR measurement can be related to the electrical field in the tissue by

$$\text{SAR} = \frac{\sigma |E|^2}{\rho}$$

Where :

σ = conductivity of the tissue (S/m)

ρ = mass density of the tissue (kg/m³)

E = RMS electric field strength (V/m)

*Note :

The primary factors that control rate of energy absorption were found to be the wavelength of the incident field in relations to the dimensions and geometry of the irradiated organism, the orientation of the organism in relation to the polarity of field vectors, the presence of reflecting surfaces, and whether conductive contact is made by the organism with a ground plane [2]

4. SAR Measurement Setup

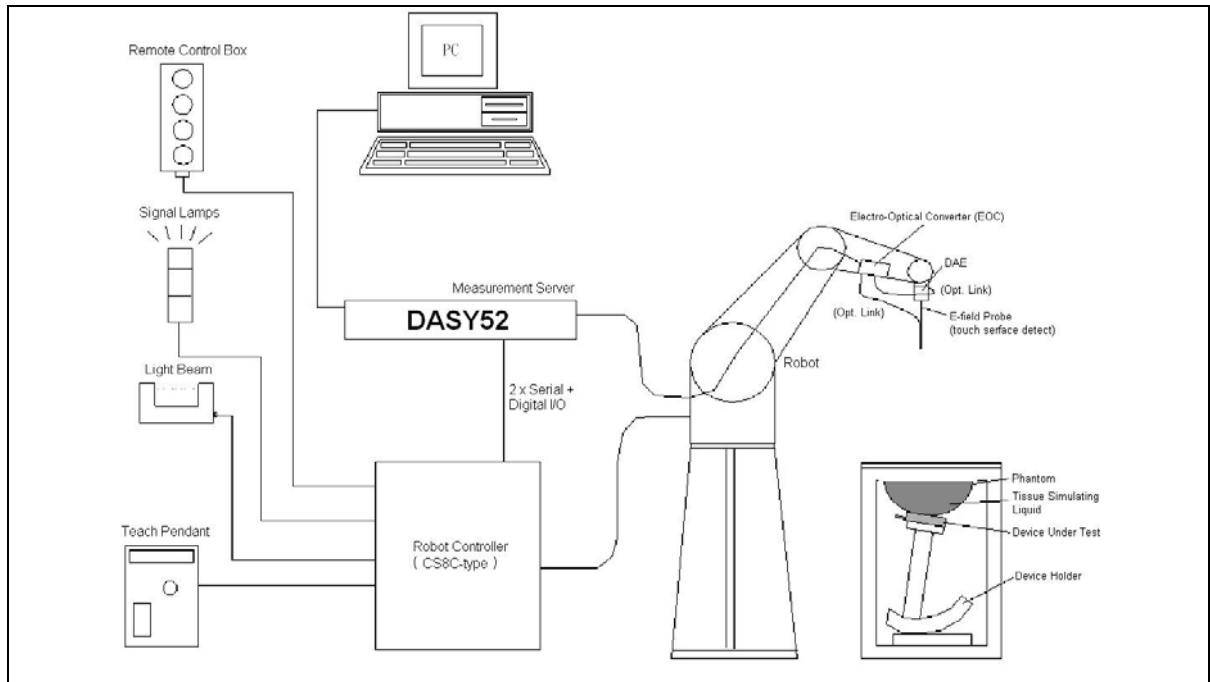

The DASY52 system for performing compliance tests consists of the following items:

1. A standard high precision 6-axis robot (Stäubli TX family) with controller, teach pendant and software. An arm extension for accommodating the data acquisition electronics (DAE).
2. A dosimetric probe, i.e., an isotropic E-field probe optimized and calibrated for usage in tissue simulating liquid. The probe is equipped with an optical surface detector system.
3. A data acquisition electronics (DAE) which performs the signal amplification, signal multiplexing, AD-conversion, offset measurements, mechanical surface detection, collision detection, etc. The unit is battery powered with standard or rechargeable batteries. The signal is optically transmitted to the EOC.
4. The function of the measurement server is to perform the time critical tasks such as signal filtering, control of the robot operation and fast movement interrupts.
5. A probe alignment unit which improves the (absolute) accuracy of the probe positioning.
6. A computer operating Windows 2000 or Windows XP.
7. DASY52 software.
8. Remote controls with teach pendant and additional circuitry for robot safety such as warning lamps, etc.
9. The SAM twin phantom enabling testing left-hand and right-hand usage.
10. The device holder for handheld mobile phones.
11. Tissue simulating liquid mixed according to the given recipes.
12. Validation dipole kits allowing validating the proper functioning of the system.

4.1 DASY E-Field Probe System

The SAR measurements were conducted with the dosimetric probe (manufactured by SPEAG), designed in the classical triangular configuration [3] and optimized for dosimetric evaluation. The probe is constructed using the thick film technique; with printed resistive lines on ceramic substrates. The probe is equipped with an optical multi-fiber line ending at the front of the probe tip. It is connected to the EOC box on the robot arm and provides an automatic detection of the phantom surface. Half of the fibers are connected to a pulsed infrared transmitter, the other half to a synchronized receiver. As the probe approaches the surface, the reflection from the surface produces a coupling from the transmitting to the receiving fibers. This reflection increases first during the approach, reaches maximum and then decreases. If the probe is flatly touching the surface, the coupling is zero. The distance of the coupling maximum to the surface is independent of the surface reflectivity and largely independent of the surface to probe angle. The DASY software reads the reflection during a software approach and looks for the maximum using a 2nd order fitting. The approach is stopped when reaching the maximum.

4.1.1 E-Field Probe Specification

Construction	Symmetrical design with triangular core Built-in shielding against static charges PEEK enclosure material (resistant to organic solvents, e.g., DGBE)
Calibration	ISO/IEC 17025 calibration service available
Frequency	10 MHz to > 6 GHz Linearity: ± 0.2 dB (30 MHz to 6 GHz)
Directivity	± 0.3 dB in brain tissue (rotation around probe axis) ± 0.5 dB in brain tissue (rotation normal probe axis)
Dimensions	Overall length: 337 mm (Tip: 20 mm) Tip diameter: 2.5 mm (Body: 12 mm) Typical distance from probe tip to dipole centers: 1 mm



Figure 3. E-field Probe



Figure 4. Probe setup on robot



4.1.2 E-Field Probe Calibration process

Dosimetric Assessment Procedure

Each E-Probe/Probe Amplifier combination has unique calibration parameters. A TEM cell calibration procedure is conducted to determine the proper amplifier settings to enter in the probe parameters. The amplifier settings are determined for a given frequency by subjecting the probe to a known E-field density (1 mW/cm²) using an RF Signal generator, TEM cell, and RF Power Meter.

Free Space Assessment

The free space E-field from amplified probe outputs is determined in a test chamber. This calibration can be performed in a TEM cell if the frequency is below 1 GHz and in a waveguide or other methodologies above 1 GHz for free space. For the free space calibration, the probe is placed in the volumetric center of the cavity and at the proper orientation with the field. The probe is rotated 360 degrees until the three channels show the maximum reading. The power density readings equates to 1 mW/cm².

Temperature Assessment

E-field temperature correlation calibration is performed in a flat phantom filled with the appropriate simulated head tissue. The E-field in the medium correlates with the temperature rise in the dielectric medium. For temperature correlation calibration a RF transparent thermistor-based temperature probe is used in conjunction with the E-field probe.

$$\text{SAR} = C \frac{\Delta T}{\Delta t}$$

Where :

- Δt = Exposure time (30 seconds),
- C = Heat capacity of tissue (head or body),
- ΔT = Temperature increase due to RF exposure.

$$\text{Or } \text{SAR} = \frac{|E|^2 \sigma}{\rho}$$

Where :

- σ = Simulated tissue conductivity,
- ρ = Tissue density (kg/m³).



4.2 Data Acquisition Electronic (DAE) System

Model : DAE3, DAE4
Construction : Signal amplifier, multiplexer, A/D converter and control logic. Serial optical link for communication with DASY4/5 embedded system (fully remote controlled). Two step probe touch detector for mechanical surface detection and emergency robot stop.
Measurement Range : -100 to +300 mV (16 bit resolution and two range settings: 4 mV, 400 mV)
Input Offset Voltage : < 5 μ V (with auto zero)
Input Bias Current : < 50 fA
Dimensions : 60 x 60 x 68 mm

4.3 Robot

Positioner : Stäubli Unimation Corp. Robot Model: TX90XL
Repeatability : ± 0.02 mm
No. of Axis : 6

4.4 Measurement Server

Processor : PC/104 with a 400MHz intel ULV Celeron
I/O-board : Link to DAE4 (or DAE3)
16-bit A/D converter for surface detection system
Digital I/O interface
Serial link to robot
Direct emergency stop output for robot

4.5 Device Holder

The DASY device holder is constructed of low-loss POM material having the following dielectric parameters: relative permittivity $\epsilon=3$ and loss tangent $\delta=0.02$. The amount of dielectric material has been reduced in the closest vicinity of the device, since measurements have suggested that the influence of the clamp on the test results could thus be lowered.

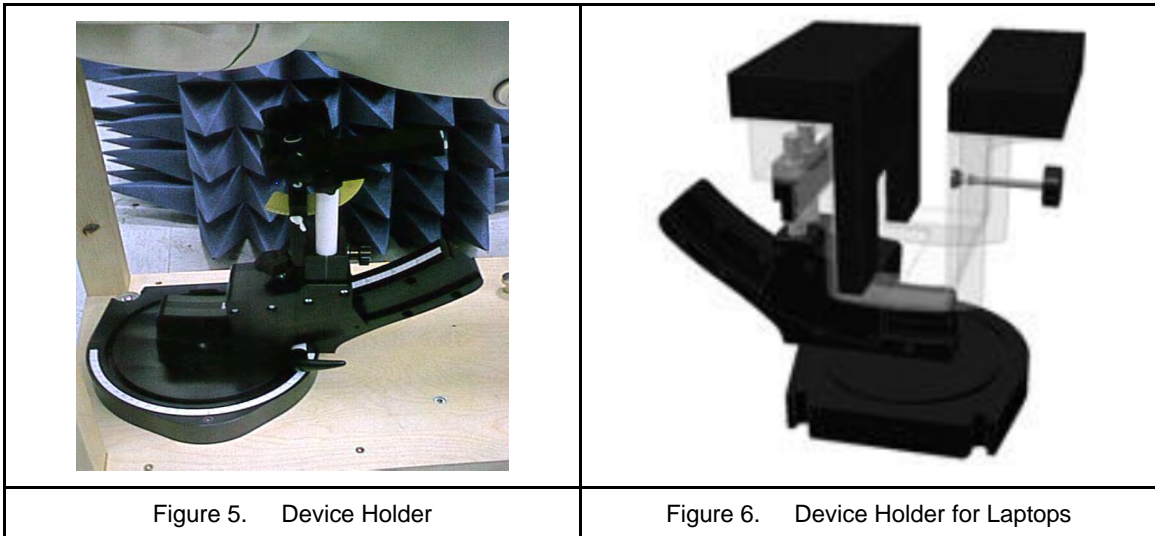

4.6 Oval Flat Phantom - ELI 4.0

The shell corresponds to the specifications of the Specific Anthropomorphic Mannequin (Oval Flat) phantom defined in IEEE 1528-2013, CENELEC 50361 and IEC 62209. It enables the dosimetric evaluation of wireless portable device usage as well as body mounted usage at the flat phantom region. A cover prevents evaporation of the liquid. Reference markings on the phantom allow the complete setup of all predefined phantom positions and measurement grids by manually teaching three points with the robot.

Shell Thickness	2 ±0.2 mm
Filling Volume	Approx. 30 liters
Dimensions	190x600x400 mm (HxLxW)
Table 1. Specification of ELI 4.0	

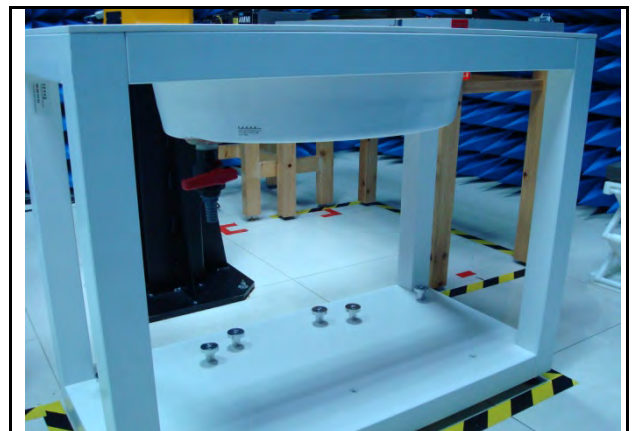

Figure 7. Oval Flat Phantom



4.7 Data Storage and Evaluation

4.7.1 Data Storage

The DASY software stores the assessed data from the data acquisition electronics as raw data (in microvolt readings from the probe sensors), together with all the necessary software parameters for the data evaluation (probe calibration data, liquid parameters and device frequency and modulation data) in measurement files with the extension DA4 or DA5. The post processing software evaluates the desired unit and format for output each time the data is visualized or exported. This allows verification of the complete software setup even after the measurement and allows correction of erroneous parameter settings. For example, if a measurement has been performed with an incorrect crest factor parameter in the device setup, the parameter can be corrected afterwards and the data can be reevaluated.

4.7.2 Data Evaluation

The DASY post processing software (SEMCAD) automatically executes the following procedures to calculate the field units from the microvolt readings at the probe connector. The parameters used in the evaluation are stored in the configuration modules of the software :

- Probe parameters : - Sensitivity $Norm_i, ai0, ai1, ai2$
- Conversion factor $ConvFi$
- Diode compression point dcp_i
- Device parameters : - Frequency f
- Crest factor cf
- Media parameters : - Conductivity σ
- Density ρ

These parameters must be set correctly in the software. They can be found in the component documents or they can be imported into the software from the configuration files issued for the DASY components. In the direct measuring mode of the multimeter option, the parameters of the actual system setup are used. In the scan visualization and export modes, the parameters stored in the corresponding document files are used.

The first step of the evaluation is a linearization of the filtered input signal to account for the compression characteristics of the detector diode. The compensation depends on the input signal, the diode type and the DC-transmission factor from the diode to the evaluation electronics. If the exciting field is pulsed, the crest factor of the signal must be known to correctly compensate for peak power. The formula for each channel can be given as :

$$V_i = U_i + U_i^2 \cdot \frac{cf}{dcp_i}$$

- With V_i = compensated signal of channel i (i = x, y, z)
 U_i = input signal of channel i (i = x, y, z)
 cf = crest factor of exciting field (DASY parameter)
 dcp_i = diode compression point (DASY parameter)



From the compensated input signals the primary field data for each channel can be evaluated :

$$E\text{-field probes : } E_i = \sqrt{\frac{V_i}{Norm_i \cdot ConvF}}$$

$$H\text{-field probes : } H_i = \sqrt{V_i} \cdot \frac{a_{i0} + a_{i1}f + a_{i2}f^2}{f}$$

- with V_i = compensated signal of channel i (i = x, y, z)
- $Norm_i$ = sensor sensitivity of channel i (i = x, y, z)
 $\mu V/(V/m)^2$ for E-field Probes
- $ConvF$ = sensitivity enhancement in solution
- a_{ij} = sensor sensitivity factors for H-field probes
- f = carrier frequency [GHz]
- E_i = electric field strength of channel i in V/m
- H_i = magnetic field strength of channel i in A/m

The RSS value of the field components gives the total field strength (Hermitian magnitude) :

$$E_{tot} = \sqrt{E_x^2 + E_y^2 + E_z^2}$$

The primary field data are used to calculate the derived field units.

$$SAR = E_{tot}^2 \cdot \frac{\sigma}{\rho \cdot 1000}$$

- with SAR = local specific absorption rate in mW/g
- E_{tot} = total field strength in V/m
- σ = conductivity in [mho/m] or [Siemens/m]
- ρ = equivalent tissue density in g/cm³

* Note : That the density is set to 1, to account for actual head tissue density rather than the density of the tissue simulating liquid.

The power flow density is calculated assuming the excitation field to be a free space field.

$$P_{pwe} = \frac{E_{tot}^2}{3770} \quad \text{or} \quad P_{pwe} = \frac{H_{tot}^2}{37.7}$$

- with P_{pwe} = equivalent power density of a plane wave in mW/cm²
- E_{tot} = total electric field strength in V/m
- H_{tot} = total magnetic field strength in A/m



5. Tissue Simulating Liquids

The mixture is calibrated to obtain proper dielectric constant (permittivity) and conductivity of the tissue.

The dielectric parameters of the liquids were verified prior to the SAR evaluation using an 85070C Dielectric Probe Kit and an E5071B Network Analyzer.

IEEE SCC-34/SC-2 in 1528 recommended Tissue Dielectric Parameters

The head tissue dielectric parameters recommended by the IEEE SCC-34/SC-2 in 1528 have been incorporated in the following table. These head parameters are derived from planar layer models simulating the highest expected SAR for the dielectric properties and tissue thickness variations in human head. Other head and body tissue parameters that have not been specified in 1528 are derived from the tissue dielectric parameters computed from the 4-Cole-Cole equation and extrapolated according to the head parameter specified in 1528.

Target Frequency	Head		Body	
(MHz)	ϵ_r	σ (S/m)	ϵ_r	σ (S/m)
150	52.3	0.76	61.9	0.80
300	45.3	0.87	58.2	0.92
450	43.5	0.87	56.7	0.94
835	41.5	0.90	55.2	0.97
900	41.5	0.97	55.0	1.05
915	41.5	0.98	55.0	1.06
1450	40.5	1.20	54.0	1.30
1610	40.3	1.29	53.8	1.40
1800 - 2000	40.0	1.40	53.3	1.52
2450	39.2	1.80	52.7	1.95
3000	38.5	2.40	52.0	2.73
5800	35.3	5.27	48.2	6.00
(ϵ_r = relative permittivity, σ = conductivity and $\rho = 1000$ kg/m ³)				

Table 2. Tissue dielectric parameters for head and body phantoms



5.1 Ingredients

The following ingredients are used:

- Water: deionized water (pure H₂O), resistivity $\geq 16 \text{ M } \Omega$ -as basis for the liquid
- Sugar: refined white sugar (typically 99.7 % sucrose, available as crystal sugar in food shops)
-to reduce relative permittivity
- Salt: pure NaCl -to increase conductivity
- Cellulose: Hydroxyethyl-cellulose, medium viscosity (75-125 mPa.s, 2 % in water, 20 °C), CAS # 54290 -to increase viscosity and to keep sugar in solution.
- Preservative: Preventol D-7 Bayer AG, D-51368 Leverkusen, CAS # 55965-84-9 -to prevent the spread of bacteria and molds
- DGBE: Diethylenglycol-monobutyl ether (DGBE), Fluka Chemie GmbH, CAS # 112-34-5 -to reduce relative permittivity

5.2 Recipes

The following tables give the recipes for tissue simulating liquids to be used in different frequency bands.

Note: The goal dielectric parameters (at 22 °C) must be achieved within a tolerance of $\pm 5\%$ for ϵ and $\pm 5\%$ for σ .

Ingredients (% by weight)	Frequency (MHz)												Frequency (GHz)	
	750		835		1750		1900		2450		2600		5 GHz	
Tissue Type	Head	Body	Head	Body	Head	Body	Head	Body	Head	Body	Head	Body	Head	Body
Water	39.28	51.30	41.45	52.40	54.50	40.20	54.90	40.40	62.70	73.20	60.30	71.40	65.5	78.6
Salt (NaCl)	1.47	1.42	1.45	1.50	0.17	0.49	0.18	0.50	0.50	0.10	0.60	0.20	0.00	0.00
Sugar	58.15	46.18	56.00	45.00	0.00	0.00	0.00	0.00	0.00	0.00	0.00	0.00	0.00	0.00
HEC	1.00	1.00	1.00	1.00	0.00	0.00	0.00	0.00	0.00	0.00	0.00	0.00	0.00	0.00
Bactericide	0.10	0.10	0.10	0.10	0.00	0.00	0.00	0.00	0.00	0.00	0.00	0.00	0.00	0.00
Triton X-100	0.00	0.00	0.00	0.00	0.00	0.00	0.00	0.00	0.00	0.00	0.00	0.00	17.2	10.7
DGBE	0.00	0.00	0.00	0.00	45.33	59.31	44.92	59.10	36.80	26.70	39.10	28.40	0.00	0.00
Dielectric Constant	41.88	54.60	42.54	56.10	40.10	53.60	39.90	54.00	39.80	52.50	39.80	52.50	35.1~ 36.2	47.9~ 49.3
Conductivity (S/m)	0.90	0.97	0.91	0.95	1.39	1.49	1.42	1.45	1.88	1.78	1.88	1.78	4.45~ 5.48	5.07~ 6.23
Diethylene Glycol Mono-hexlether	0.00	0.00	0.00	0.00	0.00	0.00	0.00	0.00	0.00	0.00	0.00	0.00	17.3	10.7

Salt: 99+ % Pure Sodium Chloride

Sugar: 98+ % Pure Sucrose

Water: De-ionized, $16 \text{ M } \Omega$ resistivity

HEC: Hydroxyethyl Cellulose

DGBE: 99+ % Di(ethylene glycol) butyl ether, [2-(2-butoxyethoxy)ethanol]

Triton X-100 (ultra pure): Polyethylene glycol mono [4-(1,1, 3, 3-tetramethylbutyl)phenyl]ether

5.3 Liquid Depth

According to KDB865664 ,the depth of tissue-equivalent liquid in a phantom must be ≥ 15.0 cm with $\leq \pm 0.5$ cm variation for SAR measurements ≤ 3 GHz and ≥ 10.0 cm with $\leq \pm 0.5$ cm variation for measurements > 3 GHz.



Figure 8. Body-Position



6. SAR Testing with RF Transmitters

6.1 SAR Testing with LTE-Cat M1 Transmitters

All SAR measurements for LTE were performed using the Anritsu MT8821C. A closed loop power control setting allowed the UE to transmit at the maximum output power during the SAR measurements. Configure the basestation to support LTE tests in respect to the 3GPP 36.521-1 section 6.2, and set ch , RB allocation number ,RB allocation offset , and send continuously Up power control commands to the device.

MPR was enabled for this device. A-MPR was disabled for all SAR test measurements.

Table 6.2.3EA-1: Maximum Power Reduction (MPR) for Power Class 3

Modulation	Channel bandwidth / Transmission bandwidth (N_{RB})						MPR (dB)
	1.4 MHz	3.0 MHz	5 MHz	10 MHz	15 MHz	20 MHz	
QPSK	>2	>2	>1	>4	-	-	≤ 1
QPSK	>5	>5	-	-	-	-	≤ 2
16 QAM	≤ 2	≤ 2	>1	>3	-	-	≤ 1
16QAM	>2	>2	>3	>5	-	-	≤ 2

By using Network Signaling Value of “NS_01”

Table 6.2.4EA-1: Additional Maximum Power Reduction (A-MPR) for category M1 UE

Network Signalling value	Requirements (subclause)	E-UTRA Band	Resources Blocks (N_{RB})	A-MPR (dB)
NS_01	6.6.2.1.1	Table 5.2-1	Table 5.4.2-1	N/A
NS_03	6.6.2.2.1	2, 4	Table 5.4.2-1	N/A
NS_04	6.6.2.2.2	41	[TBD]	[TBD]
NS_05	6.6.3.3.3.2	1	Table 5.4.2-1	N/A
NS_06	6.6.2.2.3	12, 13	Table 5.4.2-1	N/A
NS_07	6.6.2.2.3 6.6.3.3.3.3	13	Table 6.2.4-2E	
NS_08	6.6.3.3.3.4	19	Table 5.4.2-1	N/A
NS_09	6.6.3.3.3.5	21	Table 5.4.2-1	N/A
NS_10		20	Table 5.4.2-1	N/A
NS_12	6.6.3.3.3.7	26	[TBD]	
NS_13	6.6.3.3.3.8	26	Table 5.4.2-1	N/A
NS_14	6.6.3.3.3.9	26	Table 5.4.2-1	N/A
NS_15	6.6.3.3.3.10	26	Table 6.2.4-9	
NS_16	6.6.3.3.3.11	27	Table 5.4.2-1	N/A
NS_17	6.6.3.3.3.12	28	Table 5.4.2-1	N/A
NS_18	6.6.3.3.3.13	28	Table 5.4.2-1	N/A
NS_32	-	-	-	-

NB Index configurations

Table 6.2.2EA.4.1-1: Test Configuration Table

Initial Conditions				
Test Environment as specified in TS 36.508 [7] subclause 4.1	Normal, TL/VL, TL/VH, TH/VL, TH/VH			
Test Frequencies as specified in TS 36.508 [7] subclause 4.3.1	Low range, Mid range, High range			
Test Channel Bandwidths as specified in TS 36.508 [7] subclause 4.3.1	Highest			
Test Parameters for Channel Bandwidths				
Ch BW	Downlink Configuration	Uplink Configuration		
		Mod'n	RB allocation	
	N/A for Max UE output power testing		FDD and HD-FDD	TDD
5MHz		QPSK	1	1
5MHz		QPSK	3(Note 5)	3(Note 5)
10MHz		QPSK	1	1
10MHz		QPSK	4(Note 4), 5 (Note 5)	4(Note 4), 5(Note 5)
15MHz		QPSK	1	1
15MHz		QPSK	6	6
20MHz		QPSK	1	1
20MHz		QPSK	6	6
<p>Note 1: Test Channel Bandwidth is checked separately for each E-UTRA band, the applicable channel bandwidths are specified in Table 5.4.2.1-1.</p> <p>Note 2: The 1 RB allocation shall be tested at RB#0 with narrowband index 0 for low and mid range, RB #5 with max narrowband index for high range test frequency. For E-UTRA bands applied with Note 2 in Table 6.2.2 EA -1 and when channel bandwidth is larger than 4 MHz, the 1 RB allocation shall additionally be tested at RB#0 with narrowband index [3] for low range, RB #5 with max narrowband index -[3] for high range test frequency.</p> <p>Note 3: The RBstart of non-1RB allocation shall be RB #0 with narrowband index 0 for low and mid range, RB# (6 - RB allocation) with max narrowband index for high range test frequency.</p> <p>Note 4: Only applicable for Power class 3</p> <p>Note 5: Only applicable for Power class 5</p>				



6.2 LTE Frequency range and channel bandwidth

Channel bandwidth support:

Band	BW (MHz)					
	1.4	3	5	10	15	20
Band 2	V	---	---	---	---	---
Band 4	V	---	---	---	---	---
Band 12	V	---	---	---	---	---

Band	Bandwidth (MHz)	Test frequency ID	N _{UL}	Frequency of Uplink (MHz)
Band 2	1.4	Low Range	18607	1850.7
		Mid Range	18900	1880.0
		High Range	19193	1909.3
Band 4	1.4	Low Range	19957	1710.7
		Mid Range	20175	1732.5
		High Range	20393	1754.3
Band 12	1.4	Low Range	23017	699.7
		Mid Range	23095	707.5
		High Range	23173	715.3



6.2.1 Maximum power reduction (MPR)

Identify the LTE voice/data requirements in each operating mode and exposure condition with respect to head and body test configurations, antenna locations, handset flip-cover or slide positions, antenna diversity conditions etc.

The voice and data transmission:

- ◆ Data only device.

Identify if Maximum Power Reduction (MPR) is optional or mandatory, i.e. built-in by design:

- ◆ Maximum Power Reduction (MPR) is mandatory, i.e. built-in by design.
- ◆ A-MPR (additional MPR) must be disabled
- ◆ A-MPR was disabled during testing.

Maximum Power Reduction (MPR) for Power Class 3							
Channel bandwidth / Transmission bandwidth configuration (RB)							
Modulation	1.4 MHz	3 MHz	5 MHz	10 MHz	15 MHz	20MHz	MPR (dB)
QPSK	> 5	> 4	> 8	> 12	> 16	> 18	≤ 1
16 QAM	≤ 5	≤ 4	≤ 8	≤ 12	≤ 16	≤ 18	≤ 1
16 QAM	> 5	> 4	> 8	> 12	> 16	> 18	≤ 2

6.3 Power reduction

No power reduction issue.



6.4 SAR Testing with 802.11 Transmitters

SAR test reduction for 802.11 Wi-Fi transmission mode configurations are considered separately for DSSS and OFDM. An initial test position is determined to reduce the number of tests required for certain exposure configurations with multiple test positions. An initial test configuration is determined for each frequency band and aggregated band according to maximum output power, channel bandwidth, wireless mode configurations and other operating parameters to streamline the measurement requirements. For 2.4 GHz DSSS, either the initial test position or DSSS procedure is applied to reduce the number of SAR tests; these are mutually exclusive. For OFDM, an initial test position is only applicable to next to the ear, UMPC mini-tablet and hotspot mode configurations, which is tested using the initial test configuration to facilitate test reduction. For other exposure conditions with a fixed test position, SAR test reduction is determined using only the initial test configuration.

The multiple test positions require SAR measurements in head, hotspot mode or UMPC mini-tablet configurations may be reduced according to the highest reported SAR determined using the initial test position(s) by applying the DSSS or OFDM SAR measurement procedures in the required wireless mode test configuration(s). The initial test position(s) is measured using the highest measured maximum output power channel in the required wireless mode test configuration(s). When the reported SAR for the initial test position is:

- ≤ 0.4 W/kg, further SAR measurement is not required for the other test positions in that exposure configuration and wireless mode combination within the frequency band or aggregated band. DSSS and OFDM configurations are considered separately according to the required SAR procedures.
- > 0.4 W/kg, SAR is repeated using the same wireless mode test configuration tested in the initial test position to measure the subsequent next closet/smallest test separation distance and maximum coupling test position, on the highest maximum output power channel, until the reported SAR is ≤ 0.8 W/kg or all required test positions are tested.
 - For subsequent test positions with equivalent test separation distance or when exposure is dominated by coupling conditions, the position for maximum coupling condition should be tested.
 - When it is unclear, all equivalent conditions must be tested.
- For all positions/configurations tested using the initial test position and subsequent test positions, when the reported SAR is > 0.8 W/kg, measure the SAR for these positions/configurations on the subsequent next highest measured output power channel(s) until the reported SAR is ≤ 1.2 W/kg or all required test channels are considered.
 - The additional power measurements required for this step should be limited to those necessary for identifying subsequent highest output power channels to apply the test reduction.
- When the specified maximum output power is the same for both UNII 1 and UNII 2A, begin SAR measurements in UNII 2A with the channel with the highest measured output power. If the reported SAR for UNII 2A is ≤ 1.2 W/kg, SAR is not required for UNII 1; otherwise treat the remaining bands separately and test them independently for SAR.
- When the specified maximum output power is different between UNII 1 and UNII 2A, begin SAR with the band that has the higher specified maximum output. If the highest reported SAR for the band with the highest specified power is ≤ 1.2 W/kg, testing for the band with the lower specified output power is not required; otherwise test the remaining bands independently for SAR.

To determine the initial test position, Area Scans were performed to determine the position with the Maximum Value of SAR (measured). The position that produced the highest Maximum Value of SAR is considered the worst case position; thus used as the initial test position.



6.5 Conducted Power

Band	Channel Bandwidth	Modulation	Channel	Frequency (MHz)	RB Configuration		Average Power	
					Size	Offset	(dBm)	(W)
Band 2	1.4 MHz	QPSK	18607	1850.7	1	0	22.38	0.173
					1	2	22.47	0.177
					1	5	22.36	0.172
					3	0	22.42	0.175
					3	1	22.41	0.174
					3	3	22.45	0.176
					6	0	21.49	0.141
			18900	1880.0	1	0	22.48	0.177
					1	2	22.65	0.184
					1	5	22.46	0.176
					3	0	22.60	0.182
					3	1	22.51	0.178
					3	3	22.56	0.180
					6	0	21.57	0.144
			19193	1909.3	1	0	22.32	0.171
					1	2	22.47	0.177
					1	5	22.33	0.171
					3	0	22.34	0.171
					3	1	22.41	0.174
					3	3	22.46	0.176
					6	0	21.61	0.145
Band 4	1.4 MHz	QPSK	19957	1710.7	1	0	22.55	0.180
					1	2	22.52	0.179
					1	5	22.54	0.179
					3	0	22.54	0.179
					3	1	22.54	0.179
					3	3	22.58	0.181
					6	0	21.60	0.145
			20175	1732.5	1	0	22.62	0.183
					1	2	22.80	0.191
					1	5	22.57	0.181
					3	0	22.68	0.185
					3	1	22.59	0.182
					3	3	22.78	0.190
					6	0	21.71	0.148
			20393	1754.3	1	0	22.46	0.176
					1	2	22.57	0.181
					1	5	22.44	0.175
					3	0	22.52	0.179
					3	1	22.61	0.182
					3	3	22.67	0.185
					6	0	21.79	0.151



Band	Channel Bandwidth	Modulation	Channel	Frequency (MHz)	RB Configuration		Average Power	
					Size	Offset	(dBm)	(W)
Band 12	1.4 MHz	QPSK	23017	699.7	1	0	22.37	0.173
					1	2	22.53	0.179
					1	5	22.28	0.169
					3	0	22.38	0.173
					3	1	22.40	0.174
					3	3	22.52	0.179
					6	0	21.54	0.143
			23095	707.5	1	0	22.12	0.163
					1	2	22.26	0.168
					1	5	22.41	0.174
					3	0	22.37	0.173
					3	1	22.25	0.168
					3	3	22.40	0.174
					6	0	21.32	0.136
			23173	715.3	1	0	22.25	0.168
					1	2	22.25	0.168
					1	5	22.22	0.167
					3	0	22.30	0.170
					3	1	22.27	0.169
					3	3	22.39	0.173
					6	0	21.60	0.145



Band	Data Rate	CH	Frequency (MHz)	Average Power (dBm)
IEEE 802.11b	1 M	1	2412.0	3.63
		6	2437.0	2.37
		11	2462.0	3.74
	2 M	6	2437.0	2.35
	5.5 M	6	2437.0	2.34
	11 M	6	2437.0	2.32
IEEE 802.11g	6 M	1	2412.0	5.94
		6	2437.0	11.95
		11	2462.0	11.12
	9 M	6	2437.0	11.93
	12 M	6	2437.0	11.92
	18 M	6	2437.0	11.90
	24 M	6	2437.0	11.89
	36 M	6	2437.0	11.86
	48 M	6	2437.0	11.85
54 M	6	2437.0	11.81	
IEEE 802.11n 2.4 GHz 20 MHz	6.5 M	1	2412.0	4.75
		6	2437.0	10.60
		11	2462.0	9.59
	14.4 M	6	2437.0	10.57
	21.7 M	6	2437.0	10.55
	28.9 M	6	2437.0	10.53
	43.3 M	6	2437.0	10.52
	57.8 M	6	2437.0	10.51
	65 M	6	2437.0	10.49
72.2 M	6	2437.0	10.47	

Band	CH	Frequency (MHz)	Packet Type	Average Power (dBm)
Bluetooth LE	0	2402.0	---	3.86
	19	2440.0		3.71
	39	2480.0		3.46

6.6 Antenna location

Antenna to user distance (mm)		
Antenna	Front	Back
WWAN Ant	10	5
WLAN Ant	10	5
Bluetooth Ant	10	5

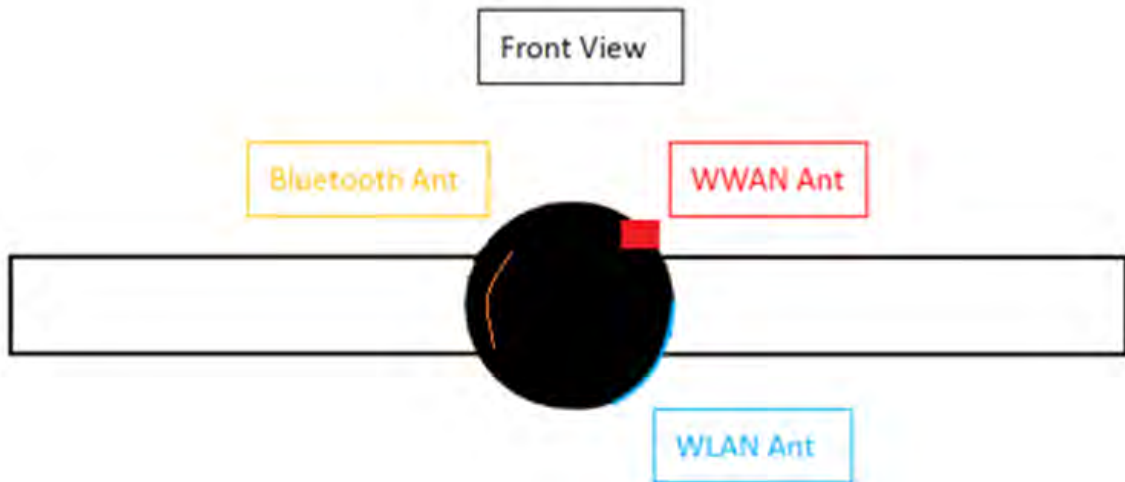



6.7 Stand-alone SAR Evaluate

Transmitter and antenna implementation as below:

Band	WWAN Ant	WLAN Ant	Bluetooth Ant
WWAN	V	---	---
WLAN	---	V	---
Bluetooth	---	---	V

Stand-alone transmission configurations as below:

Band	Front	Back
Band 2	V	V
Band 4	V	V
Band 12	V	V
WLAN 2.4 GHz	V	V
Bluetooth LE	V	V

Note: The "-" on behalf of Stand-alone SAR is not required (Refer to KDB447498 D01 v06 4.3.1 for the Standalone SAR test exclusion considerations)



Ant. Used	Band	Frequency	Tune-Power		Distance of Ant. To User (mm)		Calculated value and evaluated result			
		(GHz)	(dBm)	(mW)	Front	Back	Front	Exclusion threshold	Back	Exclusion threshold
WWAN	Band 2	1.909	23.5	224	10	5	30.9	3	61.9	7.5
							MEASURE		MEASURE	
	Band 4	1.754	23.5	224	10	5	29.7	3	59.3	7.5
							MEASURE		MEASURE	
	Band 12	0.715	23.5	224	10	5	18.9	3	37.9	7.5
							MEASURE		MEASURE	
Bluetooth	Bluetooth LE	2.48	4	3	10	5	0.5	3	0.9	7.5
							EXEMPT		EXEMPT	
WLAN	WLAN 2.4 GHz	2.462	12	16	10	5	2.5	3	5	7.5
							EXEMPT		MEASURE	

Note:

1. The test reduction for distance less than 50mm and more than 50mm. Use the max power to make sure minimum distance by evaluated for SAR testing.
2. For 100 MHz to 6 GHz and test separation distances ≤ 50 mm, the 1-g and 10-g SAR test exclusion thresholds are determined by the following:
According to KDB 447498, if the calculated threshold value are >3 then Body SAR and >7.5 then Limbs SAR testing are required.
3. Calculated Value include string "mW", that is mean through compare output power with threshold, if the output power more than threshold value the SAR test should be perform. Otherwise, the SAR test could be exempt. (> 50 mm)
4. Calculated Value only include number format, that is mean through compare output power with threshold, if the Calculated value more than 3, the SAR test should be perform. Otherwise, the SAR test could be exempt. (<50 mm)
5. When an antenna qualifies for the standalone SAR test exclusion of KDB 447498 section 4.3.1 and also transmits simultaneously with other antennas, the standalone SAR value must be estimated according to KDB 447498 section "4.3.2. Simultaneous transmission SAR test exclusion considerations b) "
6. We used highest frequency and power, that result should be evaluated the worst case.
7. Power and distance are rounded to the nearest mW and mm before calculation.
8. The result is rounded to one decimal place for comparison.



6.8 Simultaneous Transmitting Evaluate

Simultaneous transmission configurations as below:

Condition	Side	Frequency Band		
		WWAN Ant	WLAN Ant	Bluetooth Ant
1	Front	---	---	---
2	Back	---	---	---

Estimated SAR

Ant. Used	Band	Frequency	Tune-Power		Estimated SAR 1 g (W/kg)	Estimated SAR 10 g (W/kg)
		(GHz)	(dBm)	(mW)	Front	Back
WWAN	Band 2	1.909	23.5	224	---	---
	Band 4	1.754	23.5	224	---	---
	Band 12	0.715	23.5	224	---	---
Bluetooth	Bluetooth LE	2.48	4	3	0.06	0.13
WLAN	WLAN 2.4 GHz	2.462	12	16	0.33	---



6.8.1 Sum of 1-g SAR of all simultaneously transmitting

When the sum of 1-g SAR of all simultaneously transmitting antennas in and operating mode and exposure condition combination is within the SAR limit, SAR test exclusion applies to that simultaneous transmission configuration.

Sum of 1-g SAR of summary as below:

Phantom Position		WWAN Ant		WLAN Ant		Bluetooth Ant		Event
		Band	SAR _{1g} (W/Kg)	Band	SAR _{1g} (W/Kg)	Band	SAR _{1g} (W/Kg)	
Flat	Front	Band 2	0.504	IEEE 802.11g	0.159	Bluetooth LE	*0.06	<1.6
Flat	Back	Band 2	0.878	IEEE 802.11g	0.308	Bluetooth LE	*0.13	< 4

- Note:
- *=Estimated SAR
 - **The Estimated SAR 0.4 W/Kg , test separation distances is > 50 mm
 - When the sum of 1-g SAR of all simultaneously transmitting antennas in and operating mode and exposure condition combination is within the SAR limit, SAR test exclusion applies to that simultaneous transmission configuration.
 - The devices not support simultaneous transmission.



6.8.2 SAR to peak location separation ratio (SPLSR)

When the sum of SAR is larger than the limit, SAR test exclusion is determined by the SAR to peak location separation ratio. The ratio is determined by $(SAR1 + SAR2)^{1.5}/R_i$, rounded to two decimal digits, and must be ≤ 0.04 for all antenna pairs in the configuration to qualify for 1-g SAR test exclusion.

All of sum of SAR < 1.6 W/kg, therefore SPLSR is not required.

6.9 SAR test reduction according to KDB

General:

- The test data reported are the worst-case SAR value with the position set in a typical configuration. Test procedures used were according to FCC, Supplement C [June 2001], IEEE1528-2013.
- All modes of operation were investigated, and worst-case results are reported.
- Tissue parameters and temperatures are listed on the SAR plots.
- Batteries are fully charged for all readings.
- When the Channel's SAR 1 g of maximum conducted power is > 0.8 mW/g, low, middle and high channel are supposed to be tested.

KDB 447498:

- The test data reported are the worst-case SAR value with the position set in a typical configuration. Test procedures used were according to IEEE1528-2013.

KDB 865664:

- Repeated measurement is not required when the original highest measured SAR is < 0.80 W/kg.
- When the original highest measured SAR is ≥ 0.80 W/kg, repeat that measurement once.
- Perform a second repeated measurement only if the ratio of largest to smallest SAR for the original and first repeated measurements is > 1.20 or when the original or repeated measurement is ≥ 1.45 W/kg.
- Perform a third repeated measurement only if the original, first or second repeated measurement is ≥ 1.5 W/kg and the ratio of largest to smallest SAR for the original, first and second repeated measurements is > 1.20.

KDB 941225:

When the reported SAR is ≤ 0.8 W/kg, testing of the remaining RB offset configurations and required test channels is not required for 1 RB allocation, otherwise, SAR is required for the remaining required test channels and only for the RB offset configuration with the highest output power for that channel.

- For QPSK with 100 % RB allocation, SAR is not required when the highest maximum output power for 100 % RB allocation is less than the highest maximum output power in 50% and 1 RB allocations and the highest reported SAR for 1 RB and 50% RB allocation in 5.2.1 and 5.2.2 are ≤ 0.8 W/kg. Otherwise, SAR is measured for the highest output power channel and if the reported SAR is > 1.45 W/kg, the remaining required test channels must also be tested.
- SAR is required only when the highest maximum output power for the configuration in the higher order modulation is > $\frac{1}{2}$ dB higher than the same configuration in QPSK or when the reported SAR for the QPSK configuration is > 1.45 W/kg.
- For smaller channel bandwidth SAR when the highest maximum output power of a configuration requiring testing in the smaller channel bandwidth is > $\frac{1}{2}$ dB higher than the equivalent channel configurations in the largest channel bandwidth configuration or the reported SAR of a configuration for the largest channel bandwidth is > 1.45 W/kg.

KDB 248227:

- Refer 6.4 SAR Testing with 802.11 Transmitters.

7. System Verification and Validation

7.1 Symmetric Dipoles for System Verification

Construction Symmetrical dipole with 1/4 balun enables measurement of feed point impedance with NWA matched for use near flat phantoms filled with head simulating solutions Includes distance holder and tripod adaptor Calibration Calibrated SAR value for specified position and input power at the flat phantom in head simulating solutions.

Return Loss > 20 dB at specified verification position

Options Dipoles for other frequencies or solutions and other calibration conditions are available upon request

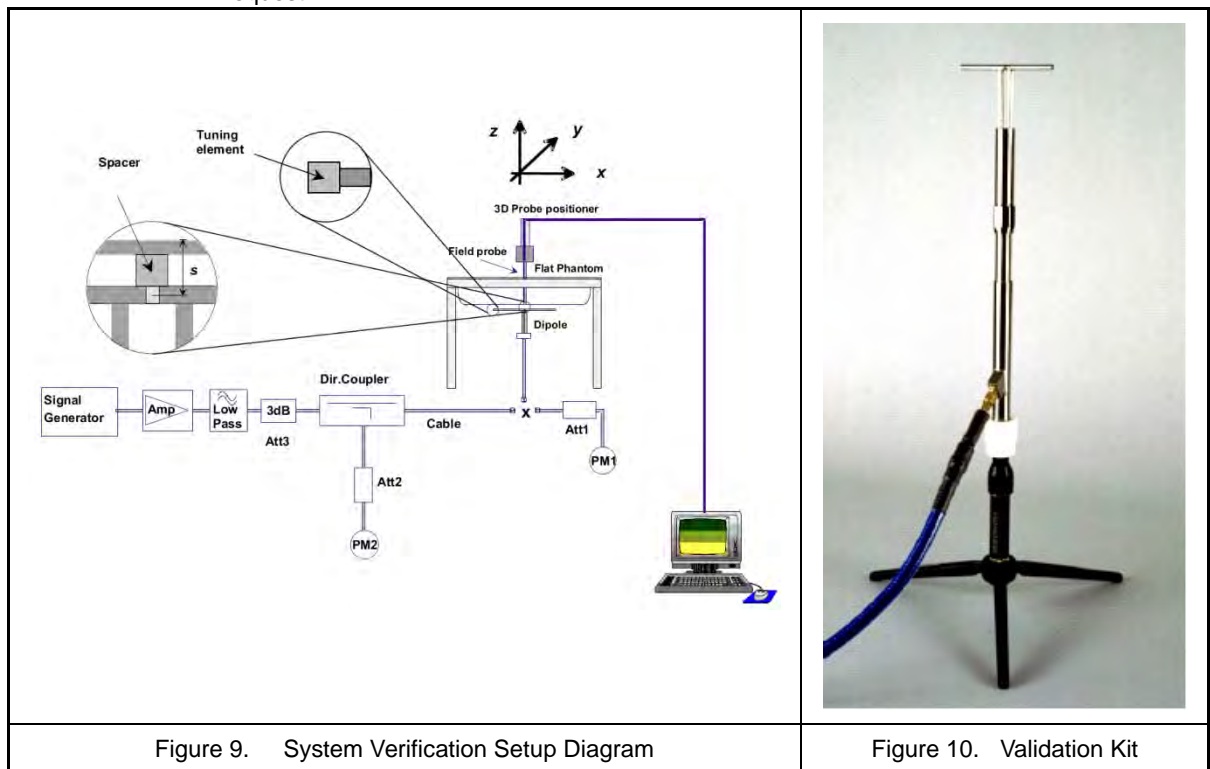

7.2 Liquid Parameters

In order to comply with the target values of IEC 62209-2, we carry the same decimal place as the target value and provide it in the report. Because the gap between the values is very small, so it look same after the carry in some coefficients.



Liquid Verify								
Ambient Temperature : 22 ± 2 °C ; Relative Humidity : 40 -70 %								
Liquid Type	Frequency	Temp (°C)	Parameters	Target Value	Measured Value	Deviation (%)	Limit (%)	Measured Date
750 MHz (Body)	698 MHz	22	ϵ_r	55.73	57.90	3.95 %	±5 %	Oct. 23, 2018
			σ	0.959	0.915	-4.17 %	±5 %	
	730 MHz	22	ϵ_r	55.61	56.65	1.98 %	±5 %	
			σ	0.962	0.926	-3.13 %	±5 %	
	750 MHz	22	ϵ_r	55.53	56.88	2.52 %	±5 %	
			σ	0.963	0.959	0.00 %	±5 %	
1750 MHz (Body)	1700 MHz	22	ϵ_r	53.56	53.05	-0.93 %	±5 %	Oct. 23, 2018
			σ	1.457	1.465	0.00 %	±5 %	
	1750 MHz	22	ϵ_r	53.43	52.95	-0.94 %	±5 %	
			σ	1.488	1.519	2.01 %	±5 %	
	1760 MHz	22	ϵ_r	53.41	52.95	-0.75 %	±5 %	
			σ	1.495	1.531	2.69 %	±5 %	
1900 MHz (Body)	1850 MHz	22	ϵ_r	53.30	55.59	4.32 %	±5 %	Oct. 23, 2018
			σ	1.520	1.459	-3.95 %	±5 %	
	1900 MHz	22	ϵ_r	53.30	55.49	4.13 %	±5 %	
			σ	1.520	1.509	-0.66 %	±5 %	
	1950 MHz	22	ϵ_r	53.30	55.26	3.75 %	±5 %	
			σ	1.520	1.552	1.97 %	±5 %	
2450 MHz (Body)	2400 MHz	22	ϵ_r	52.77	54.22	2.65 %	±5 %	Sep. 14, 2018
			σ	1.902	1.959	3.16 %	±5 %	
	2450 MHz	22	ϵ_r	52.70	54.02	2.47 %	±5 %	
			σ	1.950	2.022	3.59 %	±5 %	
	2500 MHz	22	ϵ_r	52.64	53.88	2.47 %	±5 %	
			σ	2.021	2.085	2.97 %	±5 %	

Table 3. Measured Tissue dielectric parameters for body phantoms -1



7.3 Verification Summary

Prior to the assessment, the system validation kit was used to test whether the system was operating within its specifications of $\pm 10\%$. The measured SAR will be normalized to 1 W input power. The verification was performed at 750, 1750, 1900 and 2450 MHz.

Mixture Type	Frequency (MHz)	Power	SAR _{1g} (W/Kg)	SAR _{10g} (W/Kg)	Drift (dB)	Difference percentage		Probe Model / Serial No.	Dipole Model / Serial No.	1 W Target		Date
						1 g	10 g			SAR _{1g} (W/Kg)	SAR _{10g} (W/Kg)	
Body	750	250 mW	2.2	1.48	-0.04	0.0 %	-0.8 %	EX3DV4 SN3847	D750V3 SN1004	8.8	5.97	Oct. 23, 2018
		Normalize to 1 Watt	8.80	5.92								
Body	1750	250 mW	9.25	4.88	0.02	0.5 %	-0.9 %	EX3DV4 SN3847	D1750V2 SN1023	36.8	19.7	Oct. 23, 2018
		Normalize to 1 Watt	37.00	19.52								
Body	1900	250 mW	10.4	5.3	-0.01	3.0 %	-2.8 %	EX3DV4 SN3847	D1900V2 SN5d111	40.4	21.8	Oct. 23, 2018
		Normalize to 1 Watt	41.60	21.20								
Body	2450	250 mW	12.4	5.76	-0.07	-3.5 %	-3.6 %	EX3DV4 SN3847	D2450V2 SN712	51.4	23.9	Sep. 14, 2018
		Normalize to 1 Watt	49.60	23.04								



7.4 Validation Summary

Per FCC KDB 865664 D02 v01r02, SAR system validation status should be documented to confirm measurement accuracy. The SAR systems (including SAR probes, system components and software versions) used for this device were validated against its performance specifications prior to the SAR measurements. Reference dipoles were used with the required tissue- equivalent media for system validation, according to the procedures outlined in IEEE 1528-2013 and FCC KDB 865664 D01v01r04. Since SAR probe calibrations are frequency dependent, each probe calibration point was validated at a frequency within the valid frequency range of the probe calibration point, using the system that normally operates with the probe for routine SAR measurements and according to the required tissue-equivalent media.

A tabulated summary of the system validation status including the validation date(s), measurement frequencies, SAR probes and tissue dielectric parameters as below.

Probe Type Model / Serial No.	Prob Cal. Point (MHz)	Head / Body	Cond.	Perm.	CW Validation			Mod. Validation			Date
			ϵ_r	σ	Sensitivity	Probe	Probe	Mod. Type	Duty Factor	PAR	
						Linearity	Isotropy				
EX3DV4 SN:3847	750	Body	55.53	0.963	Pass	Pass	Pass	QPSK	Pass	N/A	Oct. 23, 2018
EX3DV4 SN:3847	1750	Body	53.43	1.488	Pass	Pass	Pass	QPSK	Pass	N/A	Oct. 23, 2018
EX3DV4 SN:3847	1900	Body	53.30	1.520	Pass	Pass	Pass	GMSK/QPSK	Pass	N/A	Oct. 23, 2018
EX3DV4 SN:3847	2450	Body	52.70	1.950	Pass	Pass	Pass	OFDM	N/A	Pass	Sep.14, 2018



8. Test Equipment List

Manufacturer	Name of Equipment	Type/Model	Serial Number	Calibration	
				Cal. Date	Cal.Period
SPEAG	750 MHz System Validation Kit	D750V3	1004	09/05/2018	1 year
SPEAG	1750 MHz System Validation Kit	D1750V2	1023	06/11/2018	1 year
SPEAG	1900 MHz System Validation Kit	D1900V2	5d111	09/11/2018	1 year
SPEAG	2450 MHz System Validation Kit	D2450V2	712	04/09/2018	1 year
SPEAG	Dosimetric E-Field Probe	EX3DV4	3847	04/26/2018	1 year
SPEAG	Data Acquisition Electronics	DAE4	541	03/22/2018	1 year
SPEAG	Measurement Server	SE UMS 011 AA	1025	NCR	
SPEAG	Device Holder	N/A	N/A	NCR	
SPEAG	Phantom	ELI V4.0	1036	NCR	
SPEAG	Robot	Staubli TX90XL	F07/564ZA1/A/01	NCR	
SPEAG	Software	DASY52 V52.10 (0)	N/A	NCR	
SPEAG	Software	SEMCAD X V14.6.10 (7417)	N/A	NCR	
Anritsu	Radio Communication Analyzer	MT8821C	6201300618	06/20/2018	1 year
Agilent	ENA Series Network Analyzer	E5071B	MY42404655	04/17/2018	1 year
Agilent	Dielectric Probe Kit	85070C	US99360094	NCR	
HILA	Digital Thermometer	TM-906	GF-006	05/22/2018	1 year
Agilent	Power Sensor	8481H	3318A20779	06/12/2018	1 year
Agilent	Power Meter	EDM Series E4418B	GB40206143	06/12/2018	1 year
Agilent	Signal Generator	E8257D	MY44320425	03/08/2018	1 year
Agilent	Dual Directional Coupler	778D	50334	NCR	
Woken	Dual Directional Coupler	0100AZ20200801O	11012409517	NCR	
Mini-Circuits	Power Amplifier	EMC014225P	980292	NCR	
Mini-Circuits	Power Amplifier	EMC2830P	980293	NCR	
Aisi	Attenuator	IEAT 3dB	N/A	NCR	

Table 4. Test Equipment List



9. **Measurement Uncertainty**

Measurement uncertainties in SAR measurements are difficult to quantify due to several variables including biological, physiological, and environmental. However, we estimate the measurement uncertainties in SAR_{1g} to be less than $\pm 21.88\%$ for 300 MHz ~3 GHz and 3 GHz ~ 6 GHz $\pm 25.37\%$ [8] .

Measurement uncertainties in SAR measurements are difficult to quantify due to several variables including biological, physiological, and environmental. However, we estimate the measurement uncertainties in SAR_{10g} to be less than $\pm 21.41\%$ for 300 MHz ~3 GHz and 3 GHz ~ 6 GHz $\pm 24.97\%$ [8] .

According to Std. C95.3[9], the overall uncertainties are difficult to assess and will vary with the type of meter and usage situation. However, accuracy's of ± 1 to 3 dB can be expected in practice, with greater uncertainties in near-field situations and at higher frequencies (shorter wavelengths), or areas where large reflecting objects are present. Under optimum measurement conditions, SAR measurement uncertainties of at least ± 2 dB can be expected.



Uncertainty of a Measure SAR of EUT with DASY System

Item	Uncertainty Component	Uncertainty Value	Prob. Dist	Div.	c_i (1 g)	c_i (10 g)	Std. Unc. (1-g)	Std. Unc. (10-g)	V_i or V_{eff}
Measurement System									
u1	Probe Calibration ($k=1$)	±6.0 %	Normal	1	1	1	±6.0 %	±6.0 %	∞
u2	Axial Isotropy	±4.7 %	Rectangular	$\sqrt{3}$	0.7	0.7	±1.9 %	±1.9 %	∞
u3	Hemispherical Isotropy	±9.6 %	Rectangular	$\sqrt{3}$	0.7	0.7	±3.9 %	±3.9 %	
u4	Boundary Effect	±1.0 %	Rectangular	$\sqrt{3}$	1	1	±0.6 %	±0.6 %	∞
u5	Linearity	±4.7 %	Rectangular	$\sqrt{3}$	1	1	±2.7 %	±2.7 %	∞
u6	System Detection Limit	±1.0 %	Rectangular	$\sqrt{3}$	1	1	±0.6 %	±0.6 %	∞
u7	Readout Electronics	±0.3 %	Normal	1	1	1	±0.3 %	±0.3 %	∞
u8	Response Time	±0.8 %	Rectangular	$\sqrt{3}$	1	1	±0.5 %	±0.5 %	∞
u9	Integration Time	±1.9 %	Rectangular	$\sqrt{3}$	1	1	±1.1 %	±1.1 %	∞
u10	RF Ambient Conditions	±3.0 %	Rectangular	$\sqrt{3}$	1	1	±1.7 %	±1.7 %	∞
u11	RF Ambient Reflections	±3.0 %	Rectangular	$\sqrt{3}$	1	1	±1.7 %	±1.7 %	∞
u12	Probe Positioner Mechanical Tolerance	±0.4 %	Rectangular	$\sqrt{3}$	1	1	±0.2 %	±0.2 %	∞
u13	Probe Positioning with respect to Phantom Shell	±2.9 %	Rectangular	$\sqrt{3}$	1	1	±1.7 %	±1.7 %	∞
u14	Extrapolation, interpolation and integration Algorithms for Max. SAR Evaluation	±1.0 %	Rectangular	$\sqrt{3}$	1	1	±0.6 %	±0.6 %	∞
Test sample Related									
u15	Test sample Positioning	±2.9 %	Normal	1	1	1	±2.9 %	±2.9 %	89
u16	Device Holder Uncertainty	±3.6 %	Normal	1	1	1	±3.6 %	±3.6 %	5
u17	Output Power Variation - SAR drift measurement	±5.0 %	Rectangular	$\sqrt{3}$	1	1	±2.9 %	±2.9 %	∞
Phantom and Tissue Parameters									
u18	Phantom Uncertainty (shape and thickness tolerances)	±4.0 %	Rectangular	$\sqrt{3}$	1	1	±2.3 %	±2.3 %	∞
u19	Liquid Conductivity - deviation from target values	±5.0 %	Rectangular	$\sqrt{3}$	0.64	0.43	±1.8 %	±1.2 %	∞
u20	Liquid Conductivity - measurement uncertainty	±2.5 %	Normal	1	0.64	0.43	±1.6 %	±1.08 %	69
u21	Liquid Permittivity - deviation from target values	±5.0 %	Rectangular	$\sqrt{3}$	0.6	0.49	±1.7 %	±1.4 %	∞
u22	Liquid Permittivity - measurement uncertainty	±2.5 %	Normal	1	0.6	0.49	±1.5 %	±1.23 %	69
Combined standard uncertainty			RSS				±10.94 %	±10.71 %	380
Expanded uncertainty (95 % CONFIDENCE LEVEL)			$k=2$				±21.88 %	±21.41 %	

Table 5. Uncertainty Budget for frequency range 300 MHz to 3 GHz

Uncertainty of a Measure SAR of EUT with DASY System

Item	Uncertainty Component	Uncertainty Value	Prob. Dist	Div.	c_i (1 g)	c_i (10 g)	Std. Unc. (1-g)	Std. Unc. (10-g)	V_i or V_{eff}
Measurement System									
u1	Probe Calibration ($k=1$)	±6.5 %	Normal	1	1	1	±6.5 %	±6.5 %	∞
u2	Axial Isotropy	±4.7 %	Rectangular	$\sqrt{3}$	0.7	0.7	±1.9 %	±1.9 %	∞
u3	Hemispherical Isotropy	±9.6 %	Rectangular	$\sqrt{3}$	0.7	0.7	±3.9 %	±3.9 %	
u4	Boundary Effect	±2.0 %	Rectangular	$\sqrt{3}$	1	1	±1.2 %	±1.2 %	∞
u5	Linearity	±4.7 %	Rectangular	$\sqrt{3}$	1	1	±2.7 %	±2.7 %	∞
u6	System Detection Limit	±1.0 %	Rectangular	$\sqrt{3}$	1	1	±0.6 %	±0.6 %	∞
u7	Readout Electronics	±0.0 %	Normal	1	1	1	±0.0 %	±0.0 %	∞
u8	Response Time	±0.8 %	Rectangular	$\sqrt{3}$	1	1	±0.5 %	±0.5 %	∞
u9	Integration Time	±2.8 %	Rectangular	$\sqrt{3}$	1	1	±2.8 %	±2.8 %	∞
u10	RF Ambient Conditions	±3.0 %	Rectangular	$\sqrt{3}$	1	1	±1.7 %	±1.7 %	∞
u11	RF Ambient Reflections	±3.0 %	Rectangular	$\sqrt{3}$	1	1	±1.7 %	±1.7 %	∞
u12	Probe Positioner Mechanical Tolerance	±0.7 %	Rectangular	$\sqrt{3}$	1	1	±0.7 %	±0.7 %	∞
u13	Probe Positioning with respect to Phantom Shell	±9.9 %	Rectangular	$\sqrt{3}$	1	1	±5.7 %	±5.7 %	∞
u14	Extrapolation, interpolation and integration Algorithms for Max. SAR Evaluation	±3.0 %	Rectangular	$\sqrt{3}$	1	1	±1.7 %	±1.7 %	∞
Test sample Related									
u15	Test sample Positioning	±2.9 %	Normal	1	1	1	±2.9 %	±2.9 %	89
u16	Device Holder Uncertainty	±3.6 %	Normal	1	1	1	±3.6 %	±3.6 %	5
u17	Output Power Variation - SAR drift measurement	±5.0 %	Rectangular	$\sqrt{3}$	1	1	±2.9 %	±2.9 %	∞
Phantom and Tissue Parameters									
u18	Phantom Uncertainty (shape and thickness tolerances)	±4.0 %	Rectangular	$\sqrt{3}$	1	1	±2.3 %	±2.3 %	∞
u19	Liquid Conductivity - deviation from target values	±5.0 %	Rectangular	$\sqrt{3}$	0.64	0.43	±1.8 %	±1.2 %	∞
u20	Liquid Conductivity - measurement uncertainty	±2.5 %	Normal	1	0.64	0.43	±1.6 %	±1.08 %	69
u21	Liquid Permittivity - deviation from target values	±5.0 %	Rectangular	$\sqrt{3}$	0.6	0.49	±1.7 %	±1.4 %	∞
u22	Liquid Permittivity - measurement uncertainty	±2.5 %	Normal	1	0.6	0.49	±1.5 %	±1.23 %	69
Combined standard uncertainty			RSS				±12.68 %	±12.48 %	700
Expanded uncertainty (95 % CONFIDENCE LEVEL)			$k=2$				±25.37 %	±24.97 %	

Table 6. Uncertainty Budget for frequency range 3 GHz to 6 GHz



10. Measurement Procedure

The measurement procedures are as follows:

1. For WLAN function, engineering testing software installed on Notebook can provide continuous transmitting signal.
2. Measure output power through RF cable and power meter
3. Set scan area, grid size and other setting on the DASY software
4. Find out the largest SAR result on these testing positions of each band
5. Measure SAR results for other channels in worst SAR testing position if the SAR of highest power channel is larger than 0.8 W/kg

According to the test standard, the recommended procedure for assessing the peak spatial-average SAR value consists of the following steps:

1. Power reference measurement
2. Area scan
3. Zoom scan
4. Power drift measurement

10.1 Spatial Peak SAR Evaluation

The procedure for spatial peak SAR evaluation has been implemented according to the test standard. It can be conducted for 1 g and 10 g, as well as for user-specific masses. The DASY software includes all numerical procedures necessary to evaluate the spatial peak SAR value.

The base for the evaluation is a "cube" measurement. The measured volume must include the 1 g and 10 g cubes with the highest averaged SAR values. For that purpose, the center of the measured volume is aligned to the interpolated peak SAR value of a previously performed area scan.

The entire evaluation of the spatial peak values is performed within the post-processing engine (SEMCAD). The system always gives the maximum values for the 1 g and 10 g cubes. The algorithm to find the cube with highest averaged SAR is divided into the following stages

1. Extraction of the measured data (grid and values) from the Zoom Scan
2. Calculation of the SAR value at every measurement point based on all stored data (A/D values and measurement parameters)
3. Generation of a high-resolution mesh within the measured volume
4. Interpolation of all measured values from the measurement grid to the high-resolution grid
5. Extrapolation of the entire 3-D field distribution to the phantom surface over the distance from sensor to surface
6. Calculation of the averaged SAR within masses of 1 g and 10 g



10.2 Area & Zoom Scan Procedures

First Area Scan is used to locate the approximate location(s) of the local peak SAR value(s). The measurement grid within an Area Scan is defined by the grid extent, grid step size and grid offset. Next, in order to determine the EM field distribution in a three-dimensional spatial extension, Zoom Scan is required. The Zoom Scan measures points and step size follow as below. The Zoom Scan is performed around the highest E-field value to determine the averaged SAR-distribution over 10 g.

Grid Type	Frequency		Step size (mm)			X*Y*Z (Point)	Cube size			Step size		
			X	Y	Z		X	Y	Z	X	Y	Z
uniform grid	≤ 3 GHz	≤ 2 GHz	≤ 8	≤ 8	≤ 5	5*5*7	32	32	30	8	8	5
		2 G - 3 G	≤ 5	≤ 5	≤ 5	7*7*7	30	30	30	5	5	5
	3 - 6 GHz	3 - 4 GHz	≤ 5	≤ 5	≤ 4	7*7*8	30	30	28	5	5	4
		4 - 5 GHz	≤ 4	≤ 4	≤ 3	8*8*10	28	28	27	4	4	3
		5 - 6 GHz	≤ 4	≤ 4	≤ 2	8*8*12	28	28	22	4	4	2

(Our measure settings are refer KDB Publication 865664 D01v01r04)

10.3 Volume Scan Procedures

The volume scan is used for assess overlapping SAR distributions for antennas transmitting in different frequency bands. It is equivalent to an oversized zoom scan used in standalone measurements. The measurement volume will be used to enclose all the simultaneous transmitting antennas. For antennas transmitting simultaneously in different frequency bands, the volume scan is measured separately in each frequency band. In order to sum correctly to compute the 1 g aggregate SAR, the DUT remain in the same test position for all measurements and all volume scan use the same spatial resolution and grid spacing. When all volume scan were completed, the software, SEMCAD postprocessor can combine and subsequently superpose these measurement data to calculating the multiband SAR.

10.4 SAR Averaged Methods

In DASYS, the interpolation and extrapolation are both based on the modified Quadratic Shepard's method. The interpolation scheme combines a least-square fitted function method and a weighted average method which are the two basic types of computational interpolation and approximation. Extrapolation routines are used to obtain SAR values between the lowest measurement points and the inner phantom surface. The extrapolation distance is determined by the surface detection distance and the probe sensor offset. The uncertainty increases with the extrapolation distance. To keep the uncertainty within 1% for the 1 g and 10 g cubes, the extrapolation distance should not be larger than 5 mm.

10.5 Power Drift Monitoring

All SAR testing is under the DUT install full charged battery and transmit maximum output power. In DASYS measurement software, the power reference measurement and power drift measurement procedures are used for monitoring the power drift of DUT during SAR test. Both these procedures measure the field at a specified reference position before and after the SAR testing. The software will calculate the field difference in dB. If the power drift more than 5 %, the SAR will be retested.



11. SAR Test Results Summary

1. SAR for the initial test configuration is measured using the highest maximum output power channel.
2. Per KDB 865664 D01v01r04, for each frequency band, repeated SAR measurement is not required when the measured SAR is < 0.8 W/kg. Per KDB 865664 D01v01r04, if the extremity repeated SAR is necessary, the same procedures should be adapted for measurements according to extremity and occupational exposure limits by applying a factor of 2.5 for extremity exposure and a factor of 5 for occupational exposure to the corresponding SAR thresholds.
3. This device is in compliance with Specific Absorption Rate (SAR) for general population/uncontrolled exposure limits (4.0 W/kg for limb-worn 10 g SAR and 1.6 W/kg for 1 g SAR) specified in FCC 47 CFR part 2(2.1093) and ANSI/IEEE C95.1-1992, and had been tested in accordance with the measurement methods and procedures specified in IEEE 1528-2013 AND FCC KDB publications.
4. LTE Cat M1, the uplink subframes are scheduled at three subframes every 10 ms for all channel bandwidths (20 MHz, 15 MHz, 10 MHz, 5 MHz, 3 MHz, 1.4 MHz) according to 3GPP 36.521 specification.
5. The devices not support simultaneous transmission.
6. The device does not support voice and evaluates the watch's 10 mm thickness to perform test.

11.1 Head SAR Measurement

Evaluated head SAR is not available.

11.2 Body SAR Measurement

Index.	Band	Frequency		Bandwidth	RB Size	RB Offset	Test Position	Spacing (mm)	SAR _{1g} (W/kg)	Burst Avg Power	Max tune-up	Reported SAR _{1g} (W/kg)
		Ch.	MHz									
#6	Band 2 (QPSK)	18900	1880.0	1.4 MHz	1	2	Front	10	0.414	22.65	23.5	0.504
#5	Band 2 (QPSK)	18900	1880.0	1.4 MHz	3	0	Front	10	0.393	22.6	23	0.431
#7	Band 4 (QPSK)	20175	1732.5	1.4 MHz	1	2	Front	10	0.356	22.8	23.5	0.418
#9	Band 4 (QPSK)	20175	1732.5	1.4 MHz	3	3	Front	10	0.322	22.78	23	0.339
#11	Band 12 (QPSK)	23017	699.7	1.4 MHz	1	2	Front	10	0.055	22.53	23.5	0.069
#13	Band 12 (QPSK)	23017	699.7	1.4 MHz	3	3	Front	10	0.054	22.52	23	0.060

Index.	Band	Mode	Frequency		Data Rate	Test Position	Spacing (mm)	SAR _{1g} (W/kg)	Burst Avg Power	Max tune-up	Duty Cycle %	Reported SAR _{1g} (W/kg)
			Ch.	MHz								
#1	WLAN 2.4 GHz	802.11g	6	2437.0	6Mbps	Front	10	0.140	11.95	12	89.3	0.159

11.3 Hot-spot mode SAR Measurement

Hot-spot mode SAR is not available.



11.4 Extremity SAR Measurement

Index.	Band	Frequency		Bandwidth	RB Size	RB Offset	Test Position	Spacing (mm)	SAR _{10g} (W/kg)	Burst Avg Power	Max tune-up	Reported SAR _{10g} (W/kg)
		Ch.	MHz									
#3	Band 2 (QPSK)	18900	1880.0	1.4 MHz	1	2	Back	0	0.722	22.65	23.5	0.878
#4	Band 2 (QPSK)	18900	1880.0	1.4 MHz	3	0	Back	0	0.730	22.6	23	0.800
#8	Band 4 (QPSK)	20175	1732.5	1.4 MHz	1	2	Back	0	0.520	22.8	23.5	0.611
#10	Band 4 (QPSK)	20175	1732.5	1.4 MHz	3	3	Back	0	0.490	22.78	23	0.515
#12	Band 12 (QPSK)	23017	699.7	1.4 MHz	1	2	Back	0	0.097	22.53	23.5	0.121
#14	Band 12 (QPSK)	23017	699.7	1.4 MHz	3	3	Back	0	0.095	22.52	23	0.106

Index.	Band	Mode	Frequency		Data Rate	Test Position	Spacing (mm)	SAR _{10g} (W/kg)	Burst Avg Power	Max tune-up	Duty Cycle %	Reported SAR _{10g} (W/kg)
			Ch.	MHz								
#2	WLAN 2.4 GHz	802.11g	6	2437	6Mbps	Back	0	0.272	11.95	12	89.3	0.308



11.5 SAR Variability Measurement

Detailed evaluations please refer KDB 865664 on "SAR test reduction according to KDB" section.
SAR Measurement Variability is not available.

11.6 Std. C95.1-1992 RF Exposure Limit

Human Exposure	Population Uncontrolled Exposure (W/kg) or (mW/g)	Occupational Controlled Exposure (W/kg) or (mW/g)
Spatial Peak SAR* (head)	1.60	8.00
Spatial Peak SAR** (Whole Body)	0.08	0.40
Spatial Peak SAR*** (Partial-Body)	1.60	8.00
Spatial Peak SAR**** (Hands / Feet / Ankle / Wrist)	4.00	20.00

Table 7. Safety Limits for Partial Body Exposure

Notes :

- * The Spatial Peak value of the SAR averaged over any 1 gram of tissue.
(defined as a tissue volume in the shape of a cube) and over the appropriate averaging time.
- ** The Spatial Average value of the SAR averaged over the whole – body.
- *** The Spatial Average value of the SAR averaged over the partial – body.
- **** The Spatial Peak value of the SAR averaged over any 10 grams of tissue.
(defined as a tissue volume in the shape of a cube) and over the appropriate averaging time.

Population / Uncontrolled Environments : are defined as locations where there is the exposure of individuals who have no knowledge or control of their exposure.

Occupational / Controlled Environments : are defined as locations where there is exposure that may be incurred by persons who are aware of the potential for exposure, (i.e. as a result of employment or occupation).



12. References

- [1] Std. C95.1-1999, "American National Standard safety levels with respect to human exposure to radio frequency electromagnetic fields, 300KHz to 100GHz", New York.
- [2] NCRP, National Council on Radiation Protection and Measurements, "Biological Effects and Exposure Criteria for Radio frequency Electromagnetic Fields", NCRP report NO. 86, 1986.
- [3] T. Schmid, O. Egger, and N. Kuster, "Automatic E-field scanning system for dosimetric assessments", IEEE Transactions on Microwave Theory and Techniques, vol. 44, pp, 105-113, Jan. 1996.
- [4] K. Pokovi^c, T. Schmid, and N. Kuster, "Robust setup for precise calibration of E-field probes in tissue simulating liquids at mobile communications frequency", in ICECOM'97, Dubrovnik, October 15-17, 1997, pp.120-124.
- [5] K. Pokovi^c, T. Schmid, and N. Kuster, "E-field probe with improved isotropy in brain simulating liquids", in Proceedings of the ELMAR, Zadar, Croatia, 23-25 June, 1996, pp.172-175.
- [6] N. Kuster, and Q. Balzano, "Energy absorption mechanism by biological bodies in the near field of dipole antennas above 300 MHz", IEEE Transaction on Vehicular Technology, vol. 41, no. 1, Feb. 1992, pp. 17-23.
- [7] Robert J. Renka, "Multivariate Interpolation Of Large Sets Of Scattered Data", University of North Texas ACM Transactions on Mathematical Software, vol. 14, no. 2, June 1988 , pp. 139-148.
- [8] N. Kuster, R. Kastle, T. Schmid, Dosimetric evaluation of mobile communications equipment with known precision, IEEE Transaction on Communications, vol. E80-B, no. 5, May 1997, pp. 645-652.
- [9] Std. C95.3-1991, "IEEE Recommended Practice for the Measurement of Potentially Hazardous Electromagnetic Fields – RF and Microwave, New York: IEEE, Aug. 1992.
- [10] CENELEC CLC/SC111B, European Prestandard (prENV 50166-2), Human Exposure to Electromagnetic Fields High-frequency: 10KHz-300GHz, Jan. 1995.
- [11] IEEE Std 1528™-2013 - IEEE Recommended Practice for Determining the Peak Spatial-Average Specific Absorption Rate (SAR) in the Human Head From Wireless Communications Devices: Measurement Techniques



Appendix A - System Performance Check

Test Laboratory: A Test Lab Techno Corp.

Date/Time: 2018/10/23 PM 10:14:55

System Performance Check at 750 MHz_20181023_Body

DUT: Dipole 750 MHz; Type: D750V3; Serial: D750V3 - SN:1004

Communication System: UID 0, CW (0); Frequency: 750 MHz; Duty Cycle: 1:1

Medium parameters used: $f = 750$ MHz; $\sigma = 0.959$ S/m; $\epsilon_r = 56.881$; $\rho = 1000$ kg/m³

Phantom section: Flat Section

Measurement Standard: DASYS5 (IEEE/IEC/ANSI C63.19-2007)

DASY5.2 Configuration:

- Area Scan setting - Find Secondary Maximum Within: 2.0dB and with a peak SAR value greater than 0.5 W/Kg
- Probe: EX3DV4 - SN3847; ConvF(9.71, 9.71, 9.71); Calibrated: 2018/4/26;
- Sensor-Surface: 1.4mm (Mechanical Surface Detection)
- Electronics: DAE4 Sn541; Calibrated: 2018/3/22
- Phantom: SAM (20deg probe tilt) with CRP v4.0; Type: QD000P40CD; Serial: TP:1009
- Measurement SW: DASYS52, Version 52.10 (0); SEMCAD X Version 14.6.10 (7417)

System Performance Check at 750 MHz/Area Scan (61x121x1): Interpolated grid: dx=1.500 mm, dy=1.500 mm

Maximum value of SAR (interpolated) = 2.87 W/kg

System Performance Check at 750 MHz/Zoom Scan (5x5x7)/Cube 0: Measurement grid: dx=8mm, dy=8mm, dz=5mm

Reference Value = 56.90 V/m; Power Drift = -0.04 dB

Peak SAR (extrapolated) = 3.23 W/kg

SAR(1 g) = 2.2 W/kg; SAR(10 g) = 1.48 W/kg

Maximum value of SAR (measured) = 2.88 W/kg

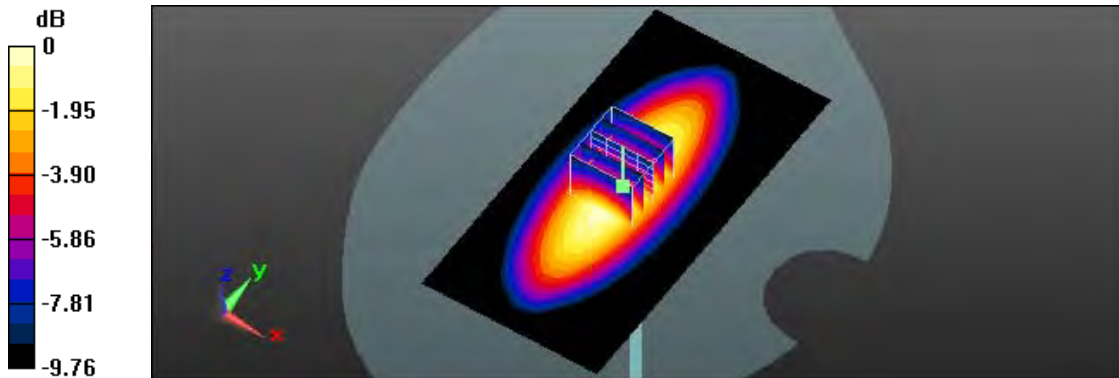

0 dB = 2.88 W/kg = 4.59 dBW/kg

Test Laboratory: A Test Lab Techno Corp.
 Date/Time: 2018/10/23 PM 06:47:28
 System Performance Check at 1750 MHz_20181023_Body
DUT: Dipole 1750 MHz; Type: D1750V2; Serial: D1750V2 - SN:1023

Communication System: UID 0, CW (0); Frequency: 1750 MHz; Duty Cycle: 1:1
 Medium parameters used: $f = 1750 \text{ MHz}$; $\sigma = 1.519 \text{ S/m}$; $\epsilon_r = 52.945$; $\rho = 1000 \text{ kg/m}^3$
 Phantom section: Flat Section
 Measurement Standard: DASYS (IEEE/IEC/ANSI C63.19-2007)

DASY5.2 Configuration:

- Area Scan setting - Find Secondary Maximum Within: 2.0dB and with a peak SAR value greater than 0.5 W/Kg
- Probe: EX3DV4 - SN3847; ConvF(7.91, 7.91, 7.91); Calibrated: 2018/4/26;
- Sensor-Surface: 1.4mm (Mechanical Surface Detection)
- Electronics: DAE4 Sn541; Calibrated: 2018/3/22
- Phantom: SAM (20deg probe tilt) with CRP v4.0; Type: QD000P40CD; Serial: TP:1009
- Measurement SW: DASYS2, Version 52.10 (0); SEMCAD X Version 14.6.10 (7417)

System Performance Check at 1750 MHz/Area Scan (61x61x1): Interpolated grid: $dx=1.500 \text{ mm}$, $dy=1.500 \text{ mm}$
 Maximum value of SAR (interpolated) = 14.2 W/kg

System Performance Check at 1750 MHz/Zoom Scan (5x5x7)/Cube 0: Measurement grid: $dx=8\text{mm}$, $dy=8\text{mm}$, $dz=5\text{mm}$

Reference Value = 100.6 V/m; Power Drift = 0.02 dB

Peak SAR (extrapolated) = 16.7 W/kg

SAR(1 g) = 9.25 W/kg; SAR(10 g) = 4.88 W/kg

Maximum value of SAR (measured) = 14.2 W/kg

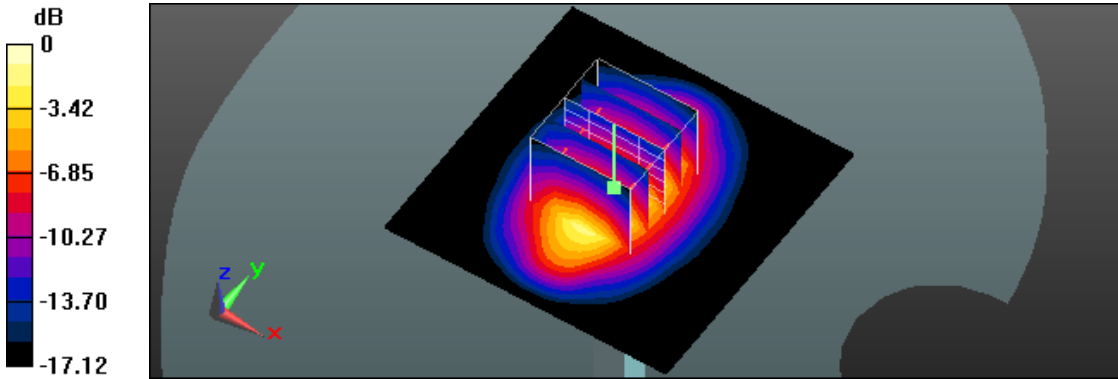

0 dB = 14.2 W/kg = 11.52 dBW/kg

Test Laboratory: A Test Lab Techno Corp.

Date/Time: 2018/10/23 PM 02:55:56

System Performance Check at 1900 MHz_20181023_Body

DUT: Dipole D1900V2_SN5d111; Type: D1900V2; Serial: D1900V2 - SN:5d111

Communication System: UID 0, CW (0); Frequency: 1900 MHz; Duty Cycle: 1:1

Medium parameters used: $f = 1900$ MHz; $\sigma = 1.509$ S/m; $\epsilon_r = 55.488$; $\rho = 1000$ kg/m³

Phantom section: Flat Section

Measurement Standard: DASYS (IEEE/IEC/ANSI C63.19-2007)

DASY5.2 Configuration:

- Area Scan setting - Find Secondary Maximum Within: 2.0dB and with a peak SAR value greater than 0.5 W/Kg
- Probe: EX3DV4 - SN3847; ConvF(7.7, 7.7, 7.7); Calibrated: 2018/4/26;
- Sensor-Surface: 1.4mm (Mechanical Surface Detection)
- Electronics: DAE4 Sn541; Calibrated: 2018/3/22
- Phantom: SAM (20deg probe tilt) with CRP v4.0; Type: QD000P40CD; Serial: TP:1009
- Measurement SW: DASYS2, Version 52.10 (0); SEMCAD X Version 14.6.10 (7417)

20181023/System Performance Check at 1900 MHz/Area Scan (61x61x1): Interpolated grid: dx=1.500 mm, dy=1.500 mm

Maximum value of SAR (interpolated) = 16.2 W/kg

20181023/System Performance Check at 1900 MHz/Zoom Scan (5x5x7)/Cube 0: Measurement grid: dx=8mm, dy=8mm, dz=5mm

Reference Value = 107.3 V/m; Power Drift = -0.01 dB

Peak SAR (extrapolated) = 19.3 W/kg

SAR(1 g) = 10.4 W/kg; SAR(10 g) = 5.3 W/kg

Maximum value of SAR (measured) = 16.2 W/kg

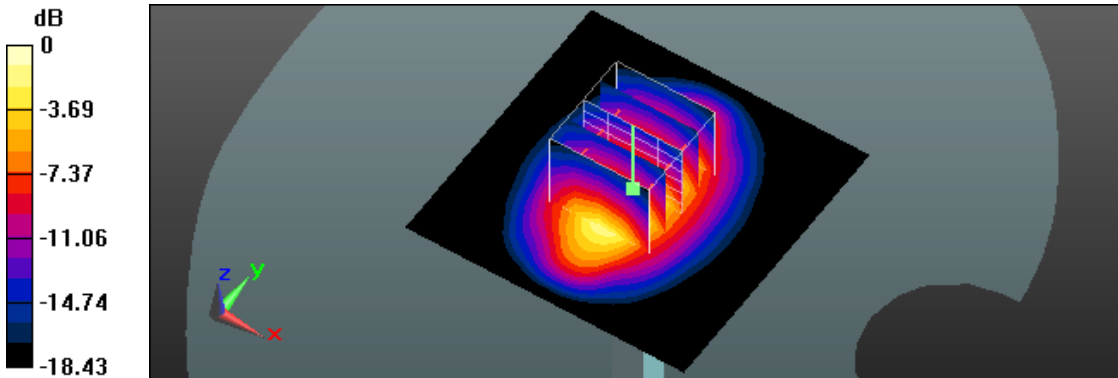

0 dB = 16.2 W/kg = 12.10 dBW/kg

Test Laboratory: A Test Lab Techno Corp.

Date/Time: 2018/9/14 PM 10:27:47

System Performance Check at 2450 MHz_20180914_Body

DUT: Dipole 2450 MHz; Type: D2450V2; Serial: D2450V2 - SN:712

Communication System: UID 0, CW (0); Frequency: 2450 MHz; Duty Cycle: 1:1

Medium parameters used: $f = 2450$ MHz; $\sigma = 2.022$ S/m; $\epsilon_r = 54.016$; $\rho = 1000$ kg/m³

Phantom section: Flat Section

Measurement Standard: DASYS5 (IEEE/IEC/ANSI C63.19-2007)

DASY5.2 Configuration:

- Area Scan setting - Find Secondary Maximum Within: 2.0dB and with a peak SAR value greater than 0.5 W/Kg
- Probe: EX3DV4 - SN3847; ConvF(7.3, 7.3, 7.3); Calibrated: 2018/4/26;
- Sensor-Surface: 1.4mm (Mechanical Surface Detection)
- Electronics: DAE4 Sn541; Calibrated: 2018/3/22
- Phantom: ELI v4.0; Type: QDOVA001BB; Serial: TP:1036
- Measurement SW: DASYS52, Version 52.10 (0); SEMCAD X Version 14.6.10 (7417)

20180914/System Performance Check at 2450 MHz/Area Scan (81x81x1): Interpolated grid: dx=1.200 mm, dy=1.200 mm

Maximum value of SAR (interpolated) = 21.2 W/kg

20180914/System Performance Check at 2450 MHz/Zoom Scan (7x7x7)/Cube 0: Measurement grid: dx=5mm, dy=5mm, dz=5mm

Reference Value = 105.8 V/m; Power Drift = -0.07 dB

Peak SAR (extrapolated) = 26.2 W/kg

SAR(1 g) = 12.4 W/kg; SAR(10 g) = 5.76 W/kg

Maximum value of SAR (measured) = 21.0 W/kg

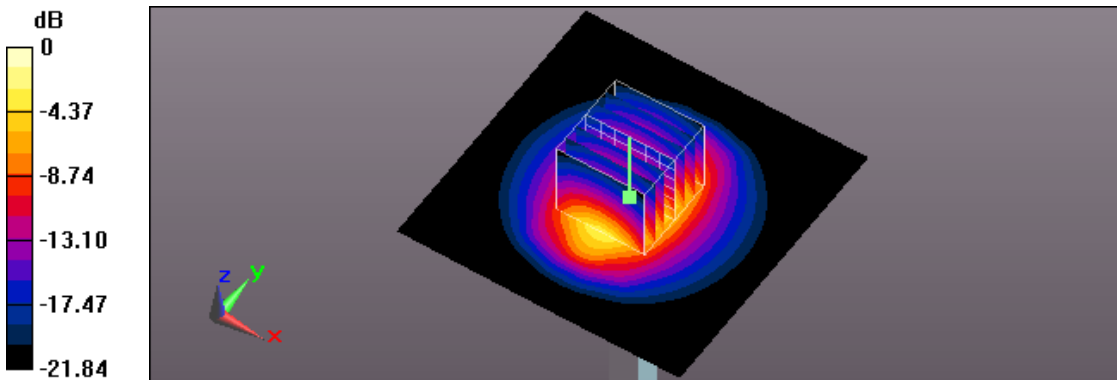

0 dB = 21.0 W/kg = 13.22 dBW/kg

Appendix B - SAR Measurement Data

Test Laboratory: A Test Lab Techno Corp.

Date/Time: 2018/10/23 PM 04:42:21

6_LTE Band2 CH18900_QPSK_BW 1.4M_1RB Size 2RB Offset_Front_10mm

DUT: R03; Type: OnePulse

Communication System: UID 0, Generic LTE (0); Frequency: 1880 MHz; Duty Cycle: 1:1

Medium parameters used: $f = 1880 \text{ MHz}$; $\sigma = 1.49 \text{ S/m}$; $\epsilon_r = 55.53$; $\rho = 1000 \text{ kg/m}^3$

Phantom section: Flat Section

Measurement Standard: DASY5 (IEEE/IEC/ANSI C63.19-2007)

DASY5.2 Configuration:

- Area Scan setting - Find Secondary Maximum Within: 2.0dB and with a peak SAR value greater than 0.5 W/Kg
- Probe: EX3DV4 - SN3847; ConvF(7.7, 7.7, 7.7); Calibrated: 2018/4/26;
- Sensor-Surface: 1.4mm (Mechanical Surface Detection)
- Electronics: DAE4 Sn541; Calibrated: 2018/3/22
- Phantom: SAM (20deg probe tilt) with CRP v4.0; Type: QD000P40CD; Serial: TP:1009
- Measurement SW: DASY52, Version 52.10 (0); SEMCAD X Version 14.6.10 (7417)

Flat/Area Scan (41x51x1): Interpolated grid: $dx=1.500 \text{ mm}$, $dy=1.500 \text{ mm}$

Maximum value of SAR (interpolated) = 0.571 W/kg

Flat/Zoom Scan (5x5x7)/Cube 0: Measurement grid: $dx=8\text{mm}$, $dy=8\text{mm}$, $dz=5\text{mm}$

Reference Value = 1.034 V/m; Power Drift = 0.10 dB

Peak SAR (extrapolated) = 0.732 W/kg

SAR(1 g) = 0.414 W/kg; SAR(10 g) = 0.204 W/kg

Maximum value of SAR (measured) = 0.589 W/kg

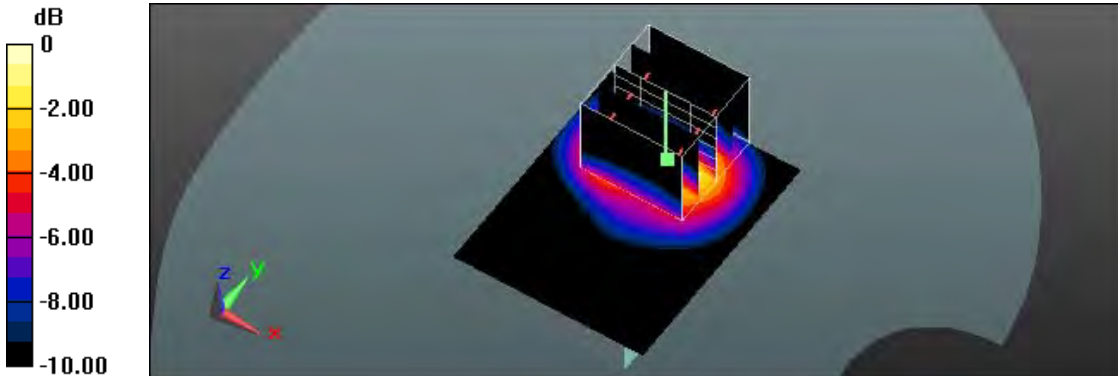

0 dB = 0.589 W/kg = -2.30 dBW/kg

Test Laboratory: A Test Lab Techno Corp.

Date/Time: 2018/10/23 PM 04:31:56

5_LTE Band2 CH18900_QPSK_BW 1.4M_3RB Size 0RB Offset_Front_10mm

DUT: R03; Type: OnePulse

Communication System: UID 0, Generic LTE (0); Frequency: 1880 MHz; Duty Cycle: 1:1

Medium parameters used: $f = 1880$ MHz; $\sigma = 1.49$ S/m; $\epsilon_r = 55.53$; $\rho = 1000$ kg/m³

Phantom section: Flat Section

Measurement Standard: DASYS (IEEE/IEC/ANSI C63.19-2007)

DASY5.2 Configuration:

- Area Scan setting - Find Secondary Maximum Within: 2.0dB and with a peak SAR value greater than 0.5 W/Kg
- Probe: EX3DV4 - SN3847; ConvF(7.7, 7.7, 7.7); Calibrated: 2018/4/26;
- Sensor-Surface: 1.4mm (Mechanical Surface Detection)
- Electronics: DAE4 Sn541; Calibrated: 2018/3/22
- Phantom: SAM (20deg probe tilt) with CRP v4.0; Type: QD000P40CD; Serial: TP:1009
- Measurement SW: DASYS2, Version 52.10 (0); SEMCAD X Version 14.6.10 (7417)

20181023/Flat/Area Scan (41x51x1): Interpolated grid: dx=1.500 mm, dy=1.500 mm

Maximum value of SAR (interpolated) = 0.595 W/kg

20181023/Flat/Zoom Scan (5x5x7)/Cube 0: Measurement grid: dx=8mm, dy=8mm, dz=5mm

Reference Value = 0.9310 V/m; Power Drift = 0.44 dB

Peak SAR (extrapolated) = 0.747 W/kg

SAR(1 g) = 0.393 W/kg; SAR(10 g) = 0.202 W/kg

Maximum value of SAR (measured) = 0.595 W/kg

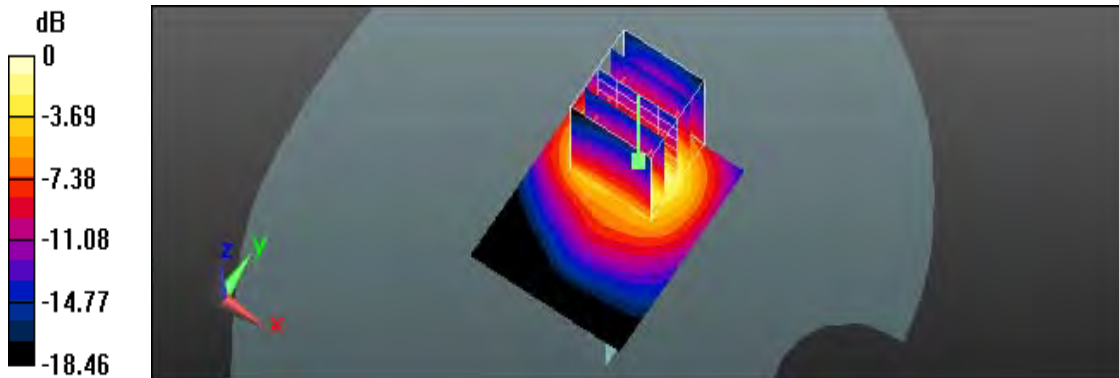

0 dB = 0.595 W/kg = -2.25 dBW/kg

Test Laboratory: A Test Lab Techno Corp.

Date/Time: 2018/10/23 PM 07:16:20

7_LTE Band4 CH20175_QPSK_BW 1.4M_1RB Size 2RB Offset_Front_10mm

DUT: R03; Type: OnePulse

Communication System: UID 0, Generic LTE (0); Frequency: 1732.5 MHz; Duty Cycle: 1:1

Medium parameters used (interpolated): $f = 1732.5$ MHz; $\sigma = 1.499$ S/m; $\epsilon_r = 52.966$; $\rho = 1000$ kg/m³

Phantom section: Flat Section

Measurement Standard: DASYS (IEEE/IEC/ANSI C63.19-2007)

DASY5.2 Configuration:

- Area Scan setting - Find Secondary Maximum Within: 2.0dB and with a peak SAR value greater than 0.5 W/Kg
- Probe: EX3DV4 - SN3847; ConvF(7.91, 7.91, 7.91); Calibrated: 2018/4/26;
- Sensor-Surface: 1.4mm (Mechanical Surface Detection)
- Electronics: DAE4 Sn541; Calibrated: 2018/3/22
- Phantom: SAM (20deg probe tilt) with CRP v4.0; Type: QD000P40CD; Serial: TP:1009
- Measurement SW: DASYS2, Version 52.10 (0); SEMCAD X Version 14.6.10 (7417)

Flat/Area Scan (41x51x1): Interpolated grid: dx=1.500 mm, dy=1.500 mm

Maximum value of SAR (interpolated) = 0.532 W/kg

Flat/Zoom Scan (5x5x7)/Cube 0: Measurement grid: dx=8mm, dy=8mm, dz=5mm

Reference Value = 9.437 V/m; Power Drift = 0.16 dB

Peak SAR (extrapolated) = 0.660 W/kg

SAR(1 g) = 0.356 W/kg; SAR(10 g) = 0.188 W/kg

Maximum value of SAR (measured) = 0.548 W/kg

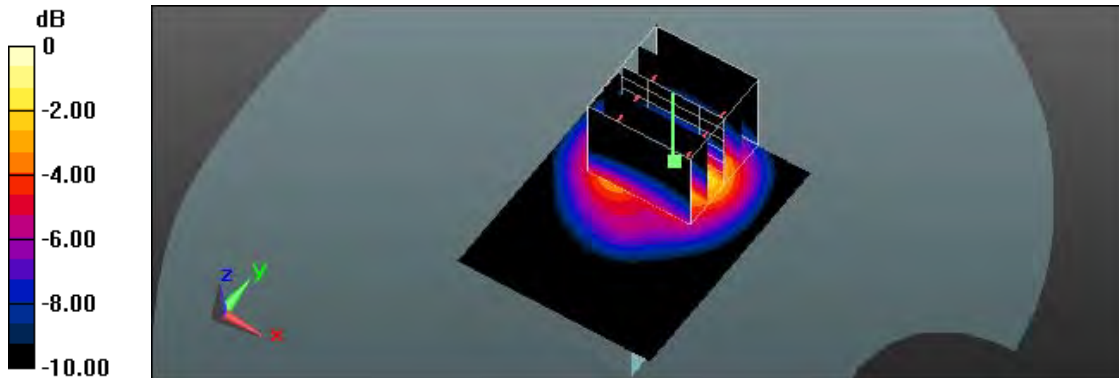

0 dB = 0.548 W/kg = -2.61 dBW/kg

Test Laboratory: A Test Lab Techno Corp.

Date/Time: 2018/10/23 PM 07:28:41

9_LTE Band4 CH20175_QPSK_BW 1.4M_3RB Size 3RB Offset_Front_10mm

DUT: R03; Type: OnePulse

Communication System: UID 0, Generic LTE (0); Frequency: 1732.5 MHz; Duty Cycle: 1:1

Medium parameters used (interpolated): $f = 1732.5$ MHz; $\sigma = 1.499$ S/m; $\epsilon_r = 52.966$; $\rho = 1000$ kg/m³

Phantom section: Flat Section

Measurement Standard: DASYS (IEEE/IEC/ANSI C63.19-2007)

DASY5.2 Configuration:

- Area Scan setting - Find Secondary Maximum Within: 2.0dB and with a peak SAR value greater than 0.5 W/Kg
- Probe: EX3DV4 - SN3847; ConvF(7.91, 7.91, 7.91); Calibrated: 2018/4/26;
- Sensor-Surface: 1.4mm (Mechanical Surface Detection)
- Electronics: DAE4 Sn541; Calibrated: 2018/3/22
- Phantom: SAM (20deg probe tilt) with CRP v4.0; Type: QD000P40CD; Serial: TP:1009
- Measurement SW: DASYS2, Version 52.10 (0); SEMCAD X Version 14.6.10 (7417)

Flat/Area Scan (41x51x1): Interpolated grid: dx=1.500 mm, dy=1.500 mm

Maximum value of SAR (interpolated) = 0.535 W/kg

Flat/Zoom Scan (5x5x7)/Cube 0: Measurement grid: dx=8mm, dy=8mm, dz=5mm

Reference Value = 9.524 V/m; Power Drift = 0.05 dB

Peak SAR (extrapolated) = 0.659 W/kg

SAR(1 g) = 0.322 W/kg; SAR(10 g) = 0.174 W/kg

Maximum value of SAR (measured) = 0.548 W/kg

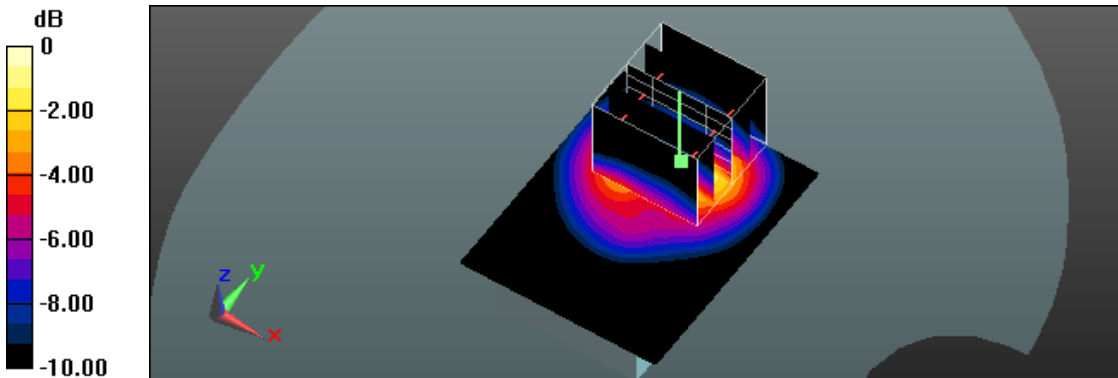

0 dB = 0.548 W/kg = -2.61 dBW/kg

Test Laboratory: A Test Lab Techno Corp.

Date/Time: 2018/10/23 PM 11:05:24

11_LTE Band12 CH23017_QPSK_BW 1.4M_1RB Size 2RB Offset_Front_10mm

DUT: R03; Type: OnePulse

Communication System: UID 0, Generic LTE (0); Frequency: 699.7 MHz; Duty Cycle: 1:1

Medium parameters used: $f = 700 \text{ MHz}$; $\sigma = 0.917 \text{ S/m}$; $\epsilon_r = 57.751$; $\rho = 1000 \text{ kg/m}^3$

Phantom section: Flat Section

Measurement Standard: DASYS (IEEE/IEC/ANSI C63.19-2007)

DASY5.2 Configuration:

- Area Scan setting - Find Secondary Maximum Within: 2.0dB and with a peak SAR value greater than 0.5 W/Kg
- Probe: EX3DV4 - SN3847; ConvF(9.71, 9.71, 9.71); Calibrated: 2018/4/26;
- Sensor-Surface: 1.4mm (Mechanical Surface Detection)
- Electronics: DAE4 Sn541; Calibrated: 2018/3/22
- Phantom: SAM (20deg probe tilt) with CRP v4.0; Type: QD000P40CD; Serial: TP:1009
- Measurement SW: DASYS2, Version 52.10 (0); SEMCAD X Version 14.6.10 (7417)

20181023/Flat/Area Scan (41x51x1): Interpolated grid: $dx=1.500 \text{ mm}$, $dy=1.500 \text{ mm}$

Maximum value of SAR (interpolated) = 0.0703 W/kg

20181023/Flat/Zoom Scan (5x5x7)/Cube 0: Measurement grid: $dx=8\text{mm}$, $dy=8\text{mm}$, $dz=5\text{mm}$

Reference Value = 5.979 V/m; Power Drift = 0.05 dB

Peak SAR (extrapolated) = 0.0820 W/kg

SAR(1 g) = 0.055 W/kg; SAR(10 g) = 0.036 W/kg

Maximum value of SAR (measured) = 0.0722 W/kg

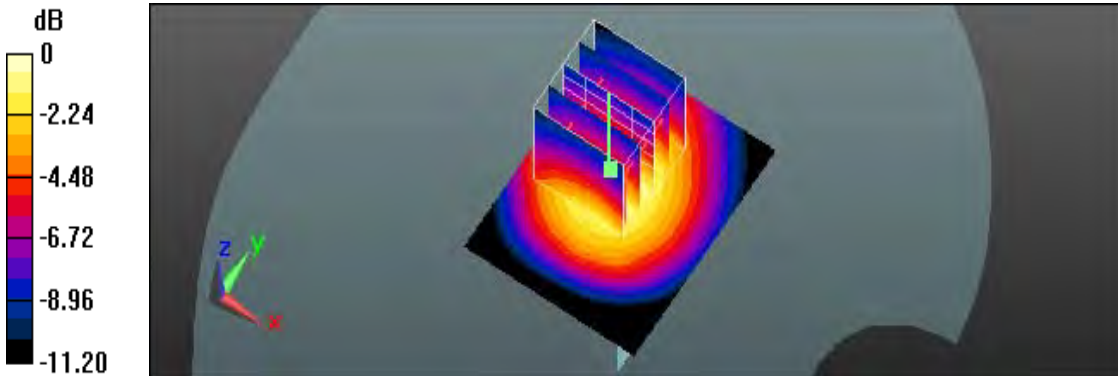

0 dB = 0.0722 W/kg = -11.41 dBW/kg

Test Laboratory: A Test Lab Techno Corp.

Date/Time: 2018/10/23 PM 11:14:18

13_LTE Band12 CH23017_QPSK_BW 1.4M_3RB Size 3RB Offset_Front_10mm

DUT: R03; Type: OnePulse

Communication System: UID 0, Generic LTE (0); Frequency: 699.7 MHz;Duty Cycle: 1:1

Medium parameters used: $f = 700$ MHz; $\sigma = 0.917$ S/m; $\epsilon_r = 57.751$; $\rho = 1000$ kg/m³

Phantom section: Flat Section

Measurement Standard: DASYS (IEEE/IEC/ANSI C63.19-2007)

DASY5.2 Configuration:

- Area Scan setting - Find Secondary Maximum Within:2.0dB and with a peak SAR value greater than 0.5 W/Kg
- Probe: EX3DV4 - SN3847; ConvF(9.71, 9.71, 9.71); Calibrated: 2018/4/26;
- Sensor-Surface: 1.4mm (Mechanical Surface Detection)
- Electronics: DAE4 Sn541; Calibrated: 2018/3/22
- Phantom: SAM (20deg probe tilt) with CRP v4.0; Type: QD000P40CD; Serial: TP:1009
- Measurement SW: DASYS2, Version 52.10 (0); SEMCAD X Version 14.6.10 (7417)

20181023/Flat/Area Scan (41x51x1): Interpolated grid: dx=1.500 mm, dy=1.500 mm

Maximum value of SAR (interpolated) = 0.0699 W/kg

20181023/Flat/Zoom Scan (5x5x7)/Cube 0: Measurement grid: dx=8mm, dy=8mm, dz=5mm

Reference Value = 5.964 V/m; Power Drift = -0.09 dB

Peak SAR (extrapolated) = 0.0800 W/kg

SAR(1 g) = 0.054 W/kg; SAR(10 g) = 0.036 W/kg

Maximum value of SAR (measured) = 0.0697 W/kg

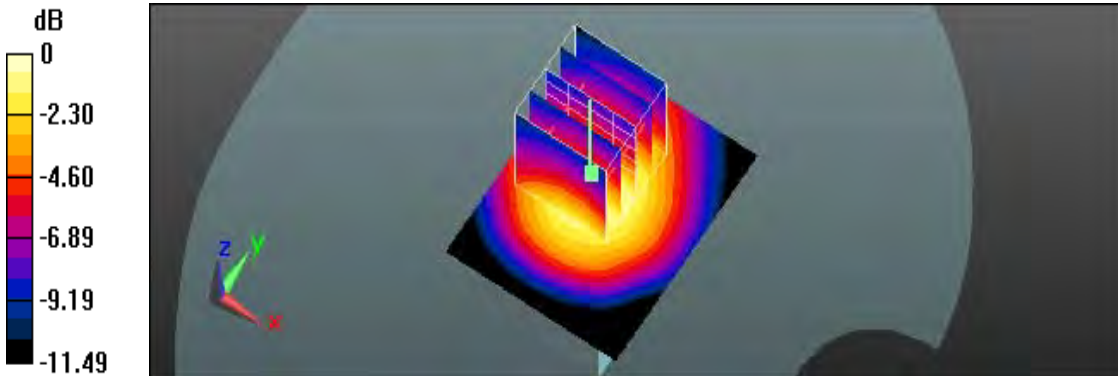

0 dB = 0.0697 W/kg = -11.57 dBW/kg

Test Laboratory: A Test Lab Techno Corp.

Date/Time: 2018/9/14 PM 09:12:10

1_IEEE 802.11g CH6_6M_Front_10mm

DUT: R03; Type: OnePulse

Communication System: UID 0, IEEE 802.11g (0); Frequency: 2437 MHz; Duty Cycle: 1:1.1197

Medium parameters used (interpolated): $f = 2437$ MHz; $\sigma = 2.005$ S/m; $\epsilon_r = 54.068$; $\rho = 1000$ kg/m³

Phantom section: Flat Section

Measurement Standard: DASYS5 (IEEE/IEC/ANSI C63.19-2007)

DASY5.2 Configuration:

- Area Scan setting - Find Secondary Maximum Within: 2.0dB and with a peak SAR value greater than 0.5 W/Kg
- Probe: EX3DV4 - SN3847; ConvF(7.3, 7.3, 7.3); Calibrated: 2018/4/26;
- Sensor-Surface: 1.4mm (Mechanical Surface Detection)
- Electronics: DAE4 Sn541; Calibrated: 2018/3/22
- Phantom: ELI v4.0; Type: QDOVA001BB; Serial: TP:1036
- Measurement SW: DASYS52, Version 52.10 (0); SEMCAD X Version 14.6.10 (7417)

Flat/Area Scan (81x81x1): Interpolated grid: dx=1.200 mm, dy=1.200 mm

Maximum value of SAR (interpolated) = 0.251 W/kg

Flat/Zoom Scan (7x7x7)/Cube 0: Measurement grid: dx=5mm, dy=5mm, dz=5mm

Reference Value = 9.051 V/m; Power Drift = -0.14 dB

Peak SAR (extrapolated) = 0.307 W/kg

SAR(1 g) = 0.140 W/kg; SAR(10 g) = 0.072 W/kg

Maximum value of SAR (measured) = 0.232 W/kg

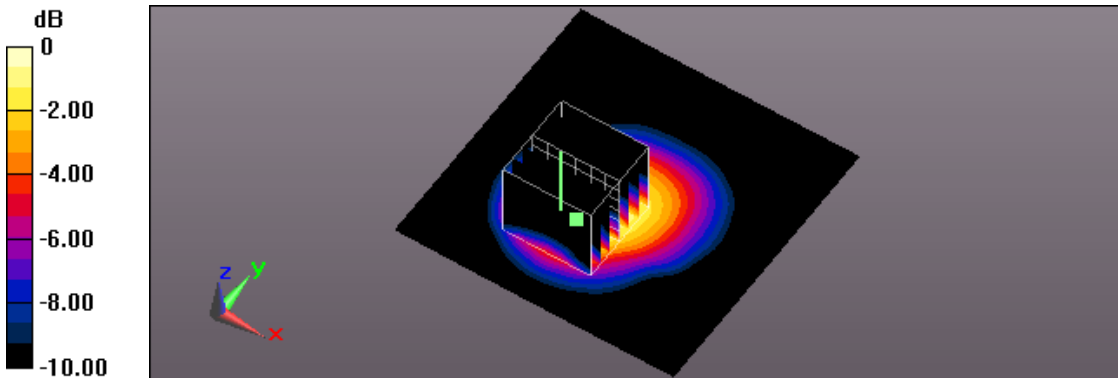

0 dB = 0.232 W/kg = -6.35 dBW/kg

Test Laboratory: A Test Lab Techno Corp.

Date/Time: 2018/10/23 PM 06:12:00

3_LTE Band2 CH18900_QPSK_BW 1.4M_1RB Size 2RB Offset_Back_0mm

DUT: R03; Type: OnePulse

Communication System: UID 0, Generic LTE (0); Frequency: 1880 MHz; Duty Cycle: 1:1

Medium parameters used: $f = 1880 \text{ MHz}$; $\sigma = 1.49 \text{ S/m}$; $\epsilon_r = 55.53$; $\rho = 1000 \text{ kg/m}^3$

Phantom section: Flat Section

Measurement Standard: DASYS (IEEE/IEC/ANSI C63.19-2007)

DASY5.2 Configuration:

- Area Scan setting - Find Secondary Maximum Within: 2.0dB and with a peak SAR value greater than 0.5 W/Kg
- Probe: EX3DV4 - SN3847; ConvF(7.7, 7.7, 7.7); Calibrated: 2018/4/26;
- Sensor-Surface: 1.4mm (Mechanical Surface Detection)
- Electronics: DAE4 Sn541; Calibrated: 2018/3/22
- Phantom: SAM (20deg probe tilt) with CRP v4.0; Type: QD000P40CD; Serial: TP:1009
- Measurement SW: DASYS2, Version 52.10 (0); SEMCAD X Version 14.6.10 (7417)

Flat/Area Scan (41x51x1): Interpolated grid: $dx=1.500 \text{ mm}$, $dy=1.500 \text{ mm}$

Maximum value of SAR (interpolated) = 2.55 W/kg

Flat/Zoom Scan (5x5x7)/Cube 0: Measurement grid: $dx=8\text{mm}$, $dy=8\text{mm}$, $dz=5\text{mm}$

Reference Value = 2.696 V/m; Power Drift = 0.12 dB

Peak SAR (extrapolated) = 3.26 W/kg

SAR(1 g) = 1.55 W/kg; SAR(10 g) = 0.722 W/kg

Maximum value of SAR (measured) = 2.62 W/kg

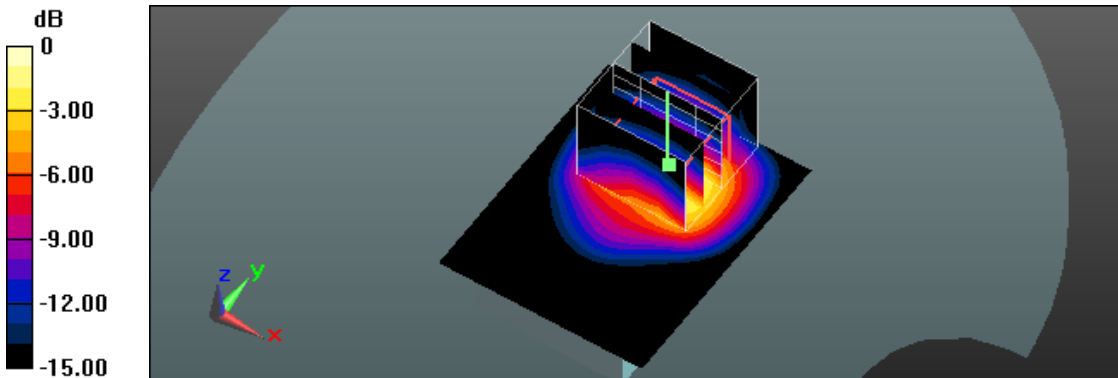

0 dB = 2.62 W/kg = 4.18 dBW/kg

Test Laboratory: A Test Lab Techno Corp.

Date/Time: 2018/10/23 PM 05:58:03

4_LTE Band2 CH18900_QPSK_BW 1.4M_3RB Size 0RB Offset_Back_0mm

DUT: R03; Type: OnePulse

Communication System: UID 0, Generic LTE (0); Frequency: 1880 MHz; Duty Cycle: 1:1

Medium parameters used: $f = 1880 \text{ MHz}$; $\sigma = 1.49 \text{ S/m}$; $\epsilon_r = 55.53$; $\rho = 1000 \text{ kg/m}^3$

Phantom section: Flat Section

Measurement Standard: DASYS5 (IEEE/IEC/ANSI C63.19-2007)

DASY5.2 Configuration:

- Area Scan setting - Find Secondary Maximum Within: 2.0dB and with a peak SAR value greater than 0.5 W/Kg
- Probe: EX3DV4 - SN3847; ConvF(7.7, 7.7, 7.7); Calibrated: 2018/4/26;
- Sensor-Surface: 1.4mm (Mechanical Surface Detection)
- Electronics: DAE4 Sn541; Calibrated: 2018/3/22
- Phantom: SAM (20deg probe tilt) with CRP v4.0; Type: QD000P40CD; Serial: TP:1009
- Measurement SW: DASYS52, Version 52.10 (0); SEMCAD X Version 14.6.10 (7417)

20181023/Flat/Area Scan (41x51x1): Interpolated grid: $dx=1.500 \text{ mm}$, $dy=1.500 \text{ mm}$

Maximum value of SAR (interpolated) = 2.57 W/kg

20181023/Flat/Zoom Scan (5x5x7)/Cube 0: Measurement grid: $dx=8\text{mm}$, $dy=8\text{mm}$, $dz=5\text{mm}$

Reference Value = 15.14 V/m; Power Drift = -0.11 dB

Peak SAR (extrapolated) = 3.32 W/kg

SAR(1 g) = 1.56 W/kg; SAR(10 g) = 0.730 W/kg

Maximum value of SAR (measured) = 2.67 W/kg

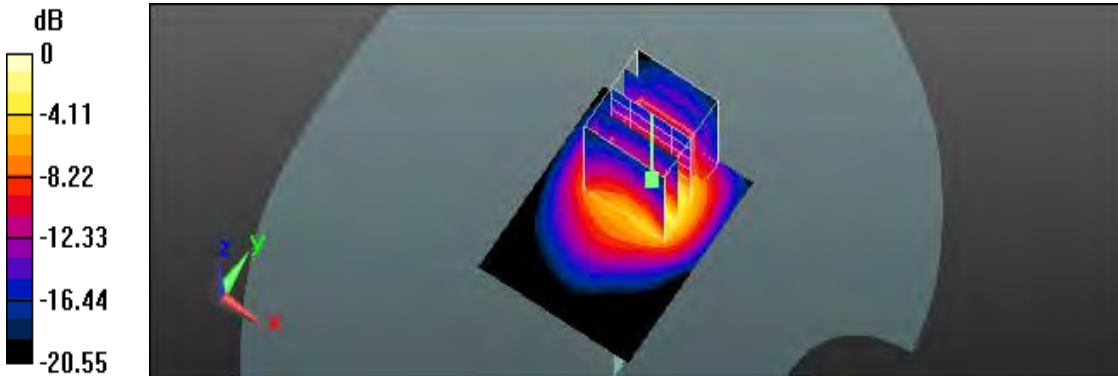

0 dB = 2.67 W/kg = 4.27 dBW/kg

Test Laboratory: A Test Lab Techno Corp.

Date/Time: 2018/10/23 PM 09:21:29

8_LTE Band4 CH20175_QPSK_BW 1.4M_1RB Size 2RB Offset_Back_0mm

DUT: R03; Type: OnePulse

Communication System: UID 0, Generic LTE (0); Frequency: 1732.5 MHz; Duty Cycle: 1:1

Medium parameters used (interpolated): $f = 1732.5$ MHz; $\sigma = 1.499$ S/m; $\epsilon_r = 52.966$; $\rho = 1000$ kg/m³

Phantom section: Flat Section

Measurement Standard: DASY5 (IEEE/IEC/ANSI C63.19-2007)

DASY5.2 Configuration:

- Area Scan setting - Find Secondary Maximum Within: 2.0dB and with a peak SAR value greater than 0.5 W/Kg
- Probe: EX3DV4 - SN3847; ConvF(7.91, 7.91, 7.91); Calibrated: 2018/4/26;
- Sensor-Surface: 1.4mm (Mechanical Surface Detection)
- Electronics: DAE4 Sn541; Calibrated: 2018/3/22
- Phantom: SAM (20deg probe tilt) with CRP v4.0; Type: QD000P40CD; Serial: TP:1009
- Measurement SW: DASY52, Version 52.10 (0); SEMCAD X Version 14.6.10 (7417)

Flat/Area Scan (41x51x1): Interpolated grid: dx=1.500 mm, dy=1.500 mm

Maximum value of SAR (interpolated) = 1.68 W/kg

Flat/Zoom Scan (5x5x7)/Cube 0: Measurement grid: dx=8mm, dy=8mm, dz=5mm

Reference Value = 17.41 V/m; Power Drift = 0.13 dB

Peak SAR (extrapolated) = 2.05 W/kg

SAR(1 g) = 1.03 W/kg; SAR(10 g) = 0.520 W/kg

Maximum value of SAR (measured) = 1.68 W/kg

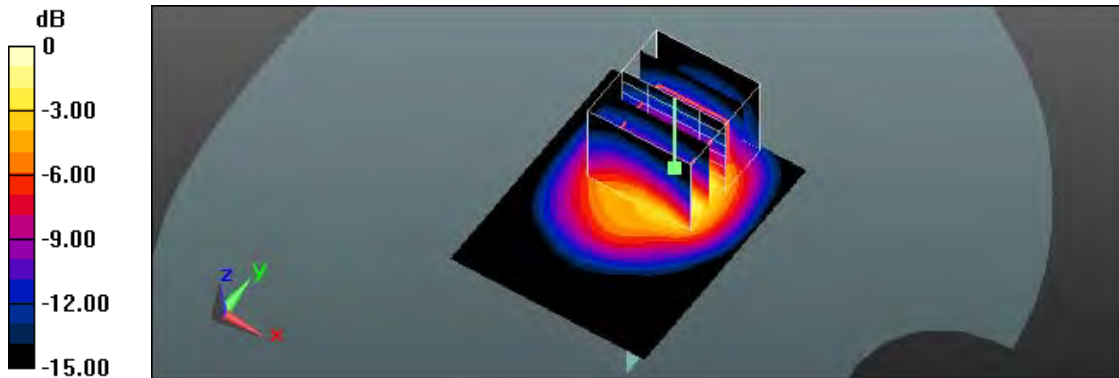

0 dB = 1.68 W/kg = 2.25 dBW/kg

Test Laboratory: A Test Lab Techno Corp.

Date/Time: 2018/10/23 PM 08:25:38

10_LTE Band4 CH20175_QPSK_BW 1.4M_3RB Size 3RB Offset_Back_0mm

DUT: R03; Type: OnePulse

Communication System: UID 0, Generic LTE (0); Frequency: 1732.5 MHz; Duty Cycle: 1:1

Medium parameters used (interpolated): $f = 1732.5$ MHz; $\sigma = 1.499$ S/m; $\epsilon_r = 52.966$; $\rho = 1000$ kg/m³

Phantom section: Flat Section

Measurement Standard: DASYS5 (IEEE/IEC/ANSI C63.19-2007)

DASY5.2 Configuration:

- Area Scan setting - Find Secondary Maximum Within:2.0dB and with a peak SAR value greater than 0.5 W/Kg
- Probe: EX3DV4 - SN3847; ConvF(7.91, 7.91, 7.91); Calibrated: 2018/4/26;
- Sensor-Surface: 1.4mm (Mechanical Surface Detection)
- Electronics: DAE4 Sn541; Calibrated: 2018/3/22
- Phantom: SAM (20deg probe tilt) with CRP v4.0; Type: QD000P40CD; Serial: TP:1009
- Measurement SW: DASYS52, Version 52.10 (0); SEMCAD X Version 14.6.10 (7417)

Flat/Area Scan (41x51x1): Interpolated grid: dx=1.500 mm, dy=1.500 mm

Maximum value of SAR (interpolated) = 1.75 W/kg

Flat/Zoom Scan (5x5x7)/Cube 0: Measurement grid: dx=8mm, dy=8mm, dz=5mm

Reference Value = 17.11 V/m; Power Drift = -0.07 dB

Peak SAR (extrapolated) = 2.26 W/kg

SAR(1 g) = 0.96 W/kg; SAR(10 g) = 0.49 W/kg

Maximum value of SAR (measured) = 1.82 W/kg

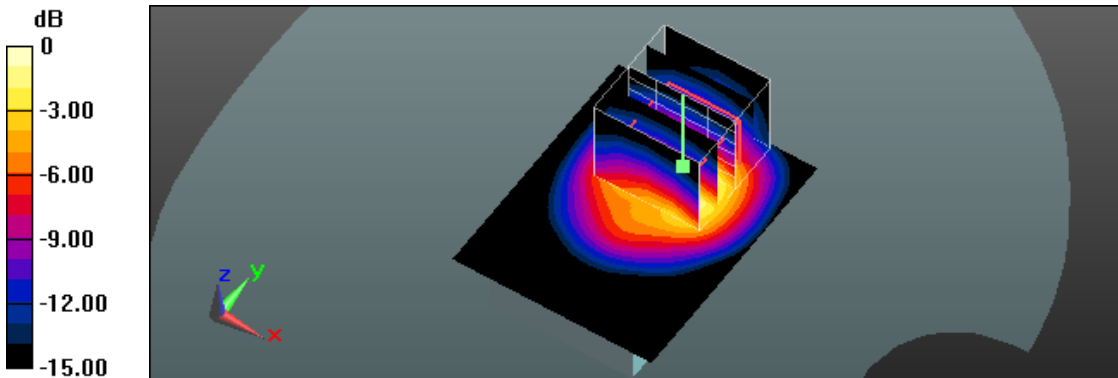

0 dB = 1.82 W/kg = 2.60 dBW/kg

Test Laboratory: A Test Lab Techno Corp.

Date/Time: 2018/10/24 AM 12:34:27

12_LTE Band12 CH23017_QPSK_BW 1.4M_1RB Size 2RB Offset_Back_0mm

DUT: R03; Type: OnePulse

Communication System: UID 0, Generic LTE (0); Frequency: 699.7 MHz;Duty Cycle: 1:1

Medium parameters used: $f = 700$ MHz; $\sigma = 0.917$ S/m; $\epsilon_r = 57.751$; $\rho = 1000$ kg/m³

Phantom section: Flat Section

Measurement Standard: DASY5 (IEEE/IEC/ANSI C63.19-2007)

DASY5.2 Configuration:

- Area Scan setting - Find Secondary Maximum Within:2.0dB and with a peak SAR value greater than 0.5 W/Kg
- Probe: EX3DV4 - SN3847; ConvF(9.71, 9.71, 9.71); Calibrated: 2018/4/26;
- Sensor-Surface: 1.4mm (Mechanical Surface Detection)
- Electronics: DAE4 Sn541; Calibrated: 2018/3/22
- Phantom: SAM (20deg probe tilt) with CRP v4.0; Type: QD000P40CD; Serial: TP:1009
- Measurement SW: DASY52, Version 52.10 (0); SEMCAD X Version 14.6.10 (7417)

20181023/Flat/Area Scan (41x51x1): Interpolated grid: dx=1.500 mm, dy=1.500 mm

Maximum value of SAR (interpolated) = 0.294 W/kg

20181023/Flat/Zoom Scan (5x5x7)/Cube 0: Measurement grid: dx=8mm, dy=8mm, dz=5mm

Reference Value = 7.051 V/m; Power Drift = -0.05 dB

Peak SAR (extrapolated) = 0.349 W/kg

SAR(1 g) = 0.165 W/kg; SAR(10 g) = 0.097 W/kg

Maximum value of SAR (measured) = 0.255 W/kg

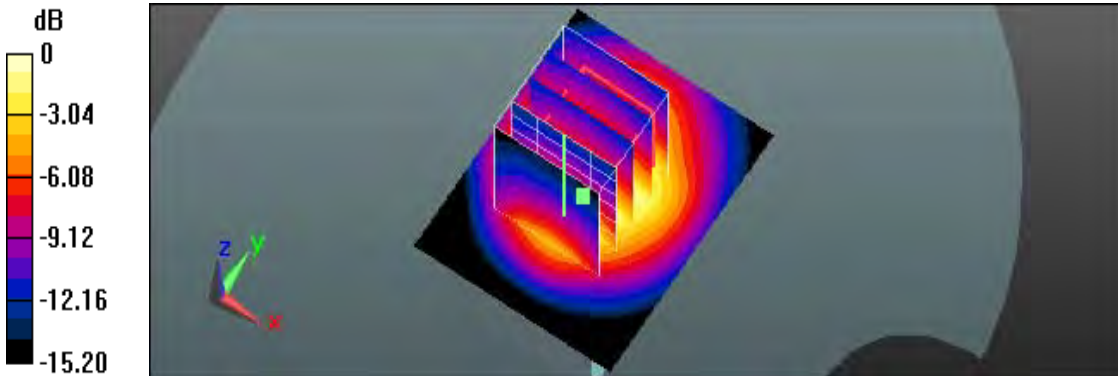

0 dB = 0.255 W/kg = -5.93 dBW/kg

Test Laboratory: A Test Lab Techno Corp.

Date/Time: 2018/10/24 AM 12:24:26

14_LTE Band12 CH23017_QPSK_BW 1.4M_3RB Size 3RB Offset_Back_0mm

DUT: R03; Type: OnePulse

Communication System: UID 0, Generic LTE (0); Frequency: 699.7 MHz;Duty Cycle: 1:1

Medium parameters used: $f = 700$ MHz; $\sigma = 0.917$ S/m; $\epsilon_r = 57.751$; $\rho = 1000$ kg/m³

Phantom section: Flat Section

Measurement Standard: DASYS (IEEE/IEC/ANSI C63.19-2007)

DASY5.2 Configuration:

- Area Scan setting - Find Secondary Maximum Within:2.0dB and with a peak SAR value greater than 0.5 W/Kg
- Probe: EX3DV4 - SN3847; ConvF(9.71, 9.71, 9.71); Calibrated: 2018/4/26;
- Sensor-Surface: 1.4mm (Mechanical Surface Detection)
- Electronics: DAE4 Sn541; Calibrated: 2018/3/22
- Phantom: SAM (20deg probe tilt) with CRP v4.0; Type: QD000P40CD; Serial: TP:1009
- Measurement SW: DASYS2, Version 52.10 (0); SEMCAD X Version 14.6.10 (7417)

20181023/Flat/Area Scan (41x51x1): Interpolated grid: dx=1.500 mm, dy=1.500 mm

Maximum value of SAR (interpolated) = 0.292 W/kg

20181023/Flat/Zoom Scan (5x5x7)/Cube 0: Measurement grid: dx=8mm, dy=8mm, dz=5mm

Reference Value = 6.877 V/m; Power Drift = 0.12 dB

Peak SAR (extrapolated) = 0.341 W/kg

SAR(1 g) = 0.161 W/kg; SAR(10 g) = 0.095 W/kg

Maximum value of SAR (measured) = 0.248 W/kg

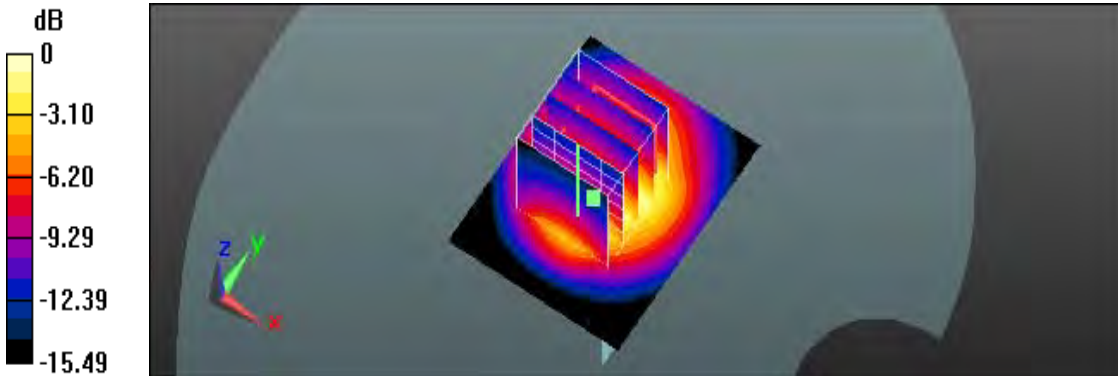

0 dB = 0.248 W/kg = -6.06 dBW/kg

Test Laboratory: A Test Lab Techno Corp.

Date/Time: 2018/9/14 PM 09:38:16

2_IEEE 802.11g CH6_6M_Back_0mm

DUT: R03; Type: OnePulse

Communication System: UID 0, IEEE 802.11g (0); Frequency: 2437 MHz; Duty Cycle: 1:1.1197

Medium parameters used (interpolated): $f = 2437$ MHz; $\sigma = 2.005$ S/m; $\epsilon_r = 54.068$; $\rho = 1000$ kg/m³

Phantom section: Flat Section

Measurement Standard: DASY5 (IEEE/IEC/ANSI C63.19-2007)

DASY5.2 Configuration:

- Area Scan setting - Find Secondary Maximum Within: 2.0dB and with a peak SAR value greater than 0.5 W/Kg
- Probe: EX3DV4 - SN3847; ConvF(7.3, 7.3, 7.3); Calibrated: 2018/4/26;
- Sensor-Surface: 1.4mm (Mechanical Surface Detection)
- Electronics: DAE4 Sn541; Calibrated: 2018/3/22
- Phantom: ELI v4.0; Type: QDOVA001BB; Serial: TP:1036
- Measurement SW: DASY52, Version 52.10 (0); SEMCAD X Version 14.6.10 (7417)

Flat/Area Scan (81x81x1): Interpolated grid: dx=1.200 mm, dy=1.200 mm

Maximum value of SAR (interpolated) = 0.969 W/kg

Flat/Zoom Scan (7x7x7)/Cube 0: Measurement grid: dx=5mm, dy=5mm, dz=5mm

Reference Value = 17.55 V/m; Power Drift = 0.18 dB

Peak SAR (extrapolated) = 1.03 W/kg

SAR(1 g) = 0.549 W/kg; SAR(10 g) = 0.272 W/kg

Maximum value of SAR (measured) = 0.841 W/kg

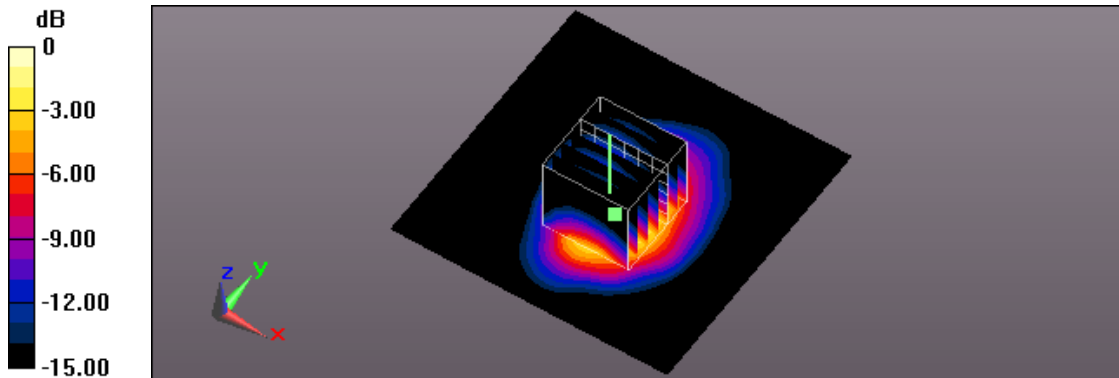

0 dB = 0.841 W/kg = -0.75 dBW/kg



Appendix C - Calibration

All of the instruments Calibration information are listed below.

- Dipole _ D750V3
- Dipole _ D1750V2
- Dipole _ D1900V2
- Dipole _ D2450V2
- Probe _ EX3DV4
- DAE _ DAE4



57-044_18-245



In Collaboration with
s p e a g
CALIBRATION LABORATORY



中国认可
国际互认
校准
CALIBRATION
CNAS L0570

Add: No.51 Xueyuan Road, Haidian District, Beijing, 100191, China
Tel: +86-10-62304633-2079 Fax: +86-10-62304633-2504
E-mail: cttl@chinattl.com http://www.chinattl.cn

Client **ATL** Certificate No: **Z18-60307**

CALIBRATION CERTIFICATE			
Object	D750V3 - SN: 1004		
Calibration Procedure(s)	FF-Z11-003-01 Calibration Procedures for dipole validation kits		
Calibration date:	September 5, 2018		
<p>This calibration Certificate documents the traceability to national standards, which realize the physical units of measurements(SI). The measurements and the uncertainties with confidence probability are given on the following pages and are part of the certificate.</p> <p>All calibrations have been conducted in the closed laboratory facility: environment temperature(22±3)°C and humidity<70%.</p> <p>Calibration Equipment used (M&TE critical for calibration)</p>			
Primary Standards	ID #	Cal Date(Calibrated by, Certificate No.)	Scheduled Calibration
Power Meter NRVD	102083	01-Nov-17 (CTTL, No.J17X08756)	Oct-18
Power sensor NRV-Z5	100542	01-Nov-17 (CTTL, No.J17X08756)	Oct-18
Reference Probe EX3DV4	SN 7464	12-Sep-17(SPEAG,No.EX3-7464_Sep17)	Sep-18
DAE4	SN 1524	13-Sep-17(SPEAG,No.DAE4-1524_Sep17)	Sep-18
Secondary Standards	ID #	Cal Date(Calibrated by, Certificate No.)	Scheduled Calibration
Signal Generator E4438C	MY49071430	23-Jan-18 (CTTL, No.J18X00560)	Jan-19
NetworkAnalyzer E5071C	MY46110673	24-Jan-18 (CTTL, No.J18X00561)	Jan-19
Calibrated by:	Name Zhao Jing	Function SAR Test Engineer	Signature
Reviewed by:	Name Lin Hao	Function SAR Test Engineer	Signature
Approved by:	Name Qi Dianyuan	Function SAR Project Leader	Signature
Issued: September 8, 2018			
This calibration certificate shall not be reproduced except in full without written approval of the laboratory.			

Certificate No: Z18-60307

Page 1 of 8

Glossary:

TSL	tissue simulating liquid
ConvF	sensitivity in TSL / NORM _{x,y,z}
N/A	not applicable or not measured

Calibration is Performed According to the Following Standards:

- IEEE Std 1528-2013, "IEEE Recommended Practice for Determining the Peak Spatial-Averaged Specific Absorption Rate (SAR) in the Human Head from Wireless Communications Devices: Measurement Techniques", June 2013
- IEC 62209-1, "Measurement procedure for assessment of specific absorption rate of human exposure to radio frequency fields from hand-held and body-mounted wireless communication devices- Part 1: Device used next to the ear (Frequency range of 300MHz to 6GHz)", July 2016
- IEC 62209-2, "Procedure to measure the Specific Absorption Rate (SAR) For wireless communication devices used in close proximity to the human body (frequency range of 30MHz to 6GHz)", March 2010
- KDB865664, SAR Measurement Requirements for 100 MHz to 6 GHz

Additional Documentation:

- DASY4/5 System Handbook

Methods Applied and Interpretation of Parameters:

- Measurement Conditions:* Further details are available from the Validation Report at the end of the certificate. All figures stated in the certificate are valid at the frequency indicated.
- Antenna Parameters with TSL:* The dipole is mounted with the spacer to position its feed point exactly below the center marking of the flat phantom section, with the arms oriented parallel to the body axis.
- Feed Point Impedance and Return Loss:* These parameters are measured with the dipole positioned under the liquid filled phantom. The impedance stated is transformed from the measurement at the SMA connector to the feed point. The Return Loss ensures low reflected power. No uncertainty required.
- Electrical Delay:* One-way delay between the SMA connector and the antenna feed point. No uncertainty required.
- SAR measured:* SAR measured at the stated antenna input power.
- SAR normalized:* SAR as measured, normalized to an input power of 1 W at the antenna connector.
- SAR for nominal TSL parameters:* The measured TSL parameters are used to calculate the nominal SAR result.

The reported uncertainty of measurement is stated as the standard uncertainty of Measurement multiplied by the coverage factor $k=2$, which for a normal distribution Corresponds to a coverage probability of approximately 95%.

Measurement Conditions

DASY system configuration, as far as not given on page 1.

DASY Version	DASY52	52.10.1.1476
Extrapolation	Advanced Extrapolation	
Phantom	Triple Flat Phantom 5.1C	
Distance Dipole Center - TSL	15 mm	with Spacer
Zoom Scan Resolution	dx, dy, dz = 5 mm	
Frequency	750 MHz ± 1 MHz	

Head TSL parameters

The following parameters and calculations were applied.

	Temperature	Permittivity	Conductivity
Nominal Head TSL parameters	22.0 °C	41.9	0.89 mho/m
Measured Head TSL parameters	(22.0 ± 0.2) °C	43.1 ± 6 %	0.87 mho/m ± 6 %
Head TSL temperature change during test	<1.0 °C	----	----

SAR result with Head TSL

SAR averaged over 1 cm ³ (1 g) of Head TSL	Condition	
SAR measured	250 mW input power	2.06 mW / g
SAR for nominal Head TSL parameters	normalized to 1W	8.47 mW /g ± 18.8 % (k=2)
SAR averaged over 10 cm ³ (10 g) of Head TSL	Condition	
SAR measured	250 mW input power	1.39 mW / g
SAR for nominal Head TSL parameters	normalized to 1W	5.68 mW /g ± 18.7 % (k=2)

Body TSL parameters

The following parameters and calculations were applied.

	Temperature	Permittivity	Conductivity
Nominal Body TSL parameters	22.0 °C	55.5	0.96 mho/m
Measured Body TSL parameters	(22.0 ± 0.2) °C	56.8 ± 6 %	0.93 mho/m ± 6 %
Body TSL temperature change during test	<1.0 °C	----	----

SAR result with Body TSL

SAR averaged over 1 cm ³ (1 g) of Body TSL	Condition	
SAR measured	250 mW input power	2.14 mW / g
SAR for nominal Body TSL parameters	normalized to 1W	8.80 mW /g ± 18.8 % (k=2)
SAR averaged over 10 cm ³ (10 g) of Body TSL	Condition	
SAR measured	250 mW input power	1.46 mW / g
SAR for nominal Body TSL parameters	normalized to 1W	5.97 mW /g ± 18.7 % (k=2)



Add: No.51 Xueyuan Road, Haidian District, Beijing, 100191, China
 Tel: +86-10-62304633-2079 Fax: +86-10-62304633-2504
 E-mail: cttl@chinattl.com http://www.chinattl.cn

Appendix (Additional assessments outside the scope of CNAS L0570)

Antenna Parameters with Head TSL

Impedance, transformed to feed point	54.4Ω+ 0.96jΩ
Return Loss	- 27.3dB

Antenna Parameters with Body TSL

Impedance, transformed to feed point	48.2Ω- 1.43jΩ
Return Loss	- 32.5dB

General Antenna Parameters and Design

Electrical Delay (one direction)	0.906 ns
----------------------------------	----------

After long term use with 100W radiated power, only a slight warming of the dipole near the feedpoint can be measured.

The dipole is made of standard semirigid coaxial cable. The center conductor of the feeding line is directly connected to the second arm of the dipole. The antenna is therefore short-circuited for DC-signals. On some of the dipoles, small end caps are added to the dipole arms in order to improve matching when loaded according to the position as explained in the "Measurement Conditions" paragraph. The SAR data are not affected by this change. The overall dipole length is still according to the Standard. No excessive force must be applied to the dipole arms, because they might bend or the soldered connections near the feedpoint may be damaged.

Additional EUT Data

Manufactured by	SPEAG
-----------------	-------

DASY5 Validation Report for Head TSL

Date: 09.05.2018

Test Laboratory: CTTL, Beijing, China

DUT: Dipole 750 MHz; Type: D750V3; Serial: D750V3 - SN: 1004

Communication System: UID 0, CW; Frequency: 750 MHz; Duty Cycle: 1:1

Medium parameters used: $f = 750 \text{ MHz}$; $\sigma = 0.866 \text{ S/m}$; $\epsilon_r = 43.13$; $\rho = 1000 \text{ kg/m}^3$

Phantom section: Right Section

DASY5 Configuration:

- Probe: EX3DV4 - SN7464; ConvF(10.57, 10.57, 10.57) @ 750 MHz; Calibrated: 9/12/2017
- Sensor-Surface: 1.4mm (Mechanical Surface Detection)
- Electronics: DAE4 Sn1524; Calibrated: 9/13/2017
- Phantom: MFP_V5.1C ; Type: QD 000 P51CA; Serial: 1062
- Measurement SW: DASY52, Version 52.10 (1); SEMCAD X Version 14.6.11 (7439)

Dipole Calibration/Zoom Scan (7x7x7) (7x7x7)/Cube 0: Measurement grid: $dx=5\text{mm}$, $dy=5\text{mm}$, $dz=5\text{mm}$

Reference Value = 55.10 V/m; Power Drift = -0.07 dB

Peak SAR (extrapolated) = 3.01 W/kg

SAR(1 g) = 2.06 W/kg; SAR(10 g) = 1.39 W/kg

Maximum value of SAR (measured) = 2.69 W/kg

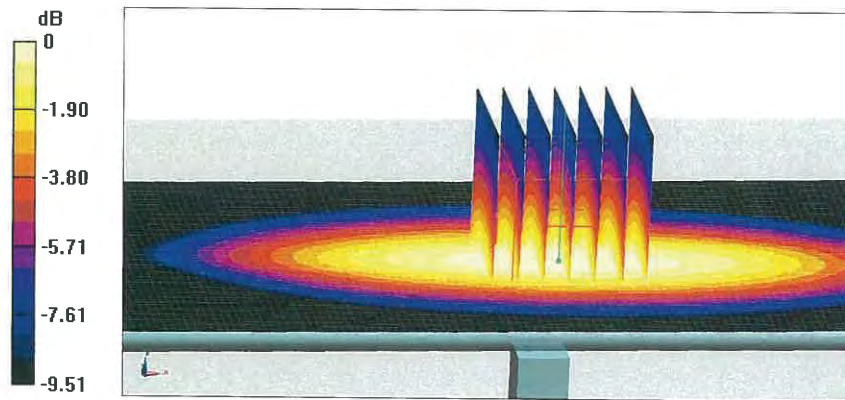



In Collaboration with
s p e a g
CALIBRATION LABORATORY

Add: No.51 Xueyuan Road, Haidian District, Beijing, 100191, China
Tel: +86-10-62304633-2079 Fax: +86-10-62304633-2504
E-mail: cttl@chinattl.com http://www.chinattl.cn

Impedance Measurement Plot for Head TSL

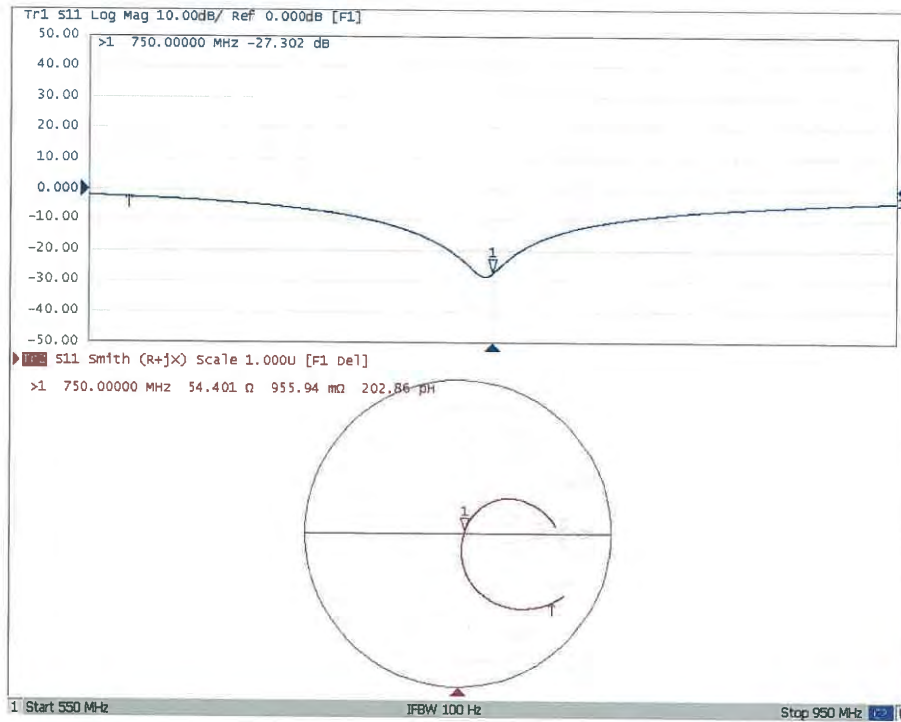

DASY5 Validation Report for Body TSL

Date: 09.05.2018

Test Laboratory: CTTL, Beijing, China

DUT: Dipole 750 MHz; Type: D750V3; Serial: D750V3 - SN: 1004

Communication System: UID 0, CW; Frequency: 750 MHz; Duty Cycle: 1:1

Medium parameters used: $f = 750 \text{ MHz}$; $\sigma = 0.932 \text{ S/m}$; $\epsilon_r = 56.82$; $\rho = 1000 \text{ kg/m}^3$

Phantom section: Center Section

DASY5 Configuration:

- Probe: EX3DV4 - SN7464; ConvF(10.63, 10.63, 10.63) @ 750 MHz; Calibrated: 9/12/2017
- Sensor-Surface: 1.4mm (Mechanical Surface Detection)
- Electronics: DAE4 Sn1524; Calibrated: 9/13/2017
- Phantom: MFP_V5.1C ; Type: QD 000 P51CA; Serial: 1062
- Measurement SW: DASY52, Version 52.10 (1); SEMCAD X Version 14.6.11 (7439)

Dipole Calibration/Zoom Scan (7x7x7) (7x7x7)/Cube 0: Measurement grid: $dx=5\text{mm}$, $dy=5\text{mm}$, $dz=5\text{mm}$

Reference Value = 54.38 V/m; Power Drift = -0.05 dB

Peak SAR (extrapolated) = 3.08 W/kg

SAR(1 g) = 2.14 W/kg; SAR(10 g) = 1.46 W/kg

Maximum value of SAR (measured) = 2.77 W/kg

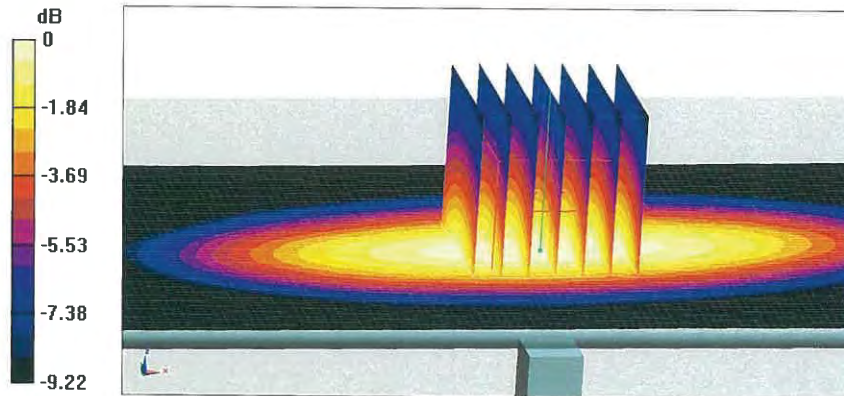

0 dB = 2.77 W/kg = 4.42 dBW/kg



In Collaboration with
s p e a g
CALIBRATION LABORATORY

Add: No.51 Xueyuan Road, Haidian District, Beijing, 100191, China
Tel: +86-10-62304633-2079 Fax: +86-10-62304633-2504
E-mail: cttl@chinattl.com http://www.chinattl.cn

Impedance Measurement Plot for Body TSL

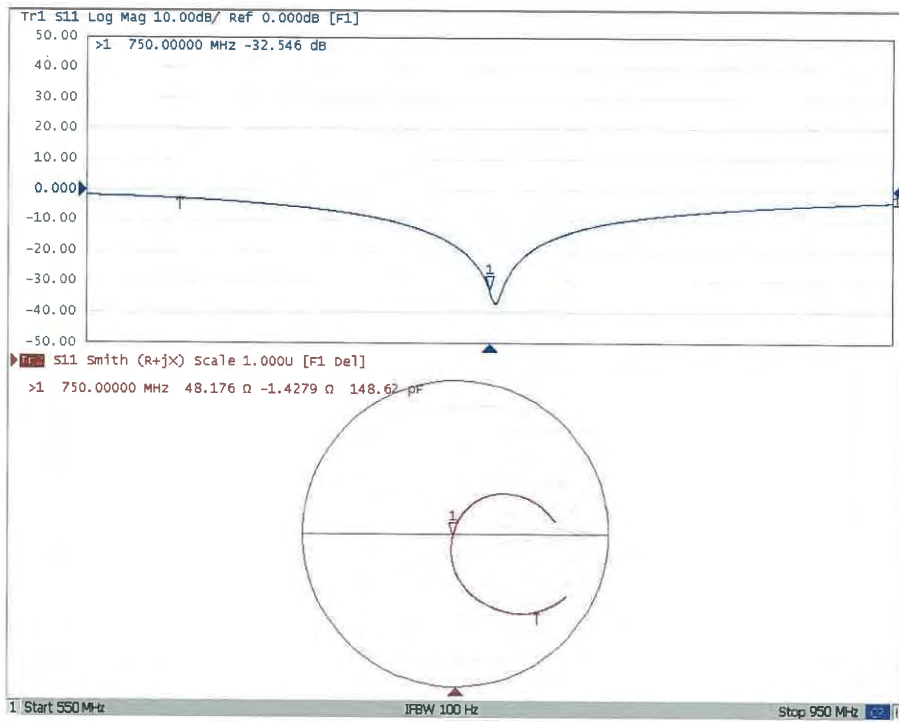

**Calibration Laboratory of
Schmid & Partner
Engineering AG**
Zeughausstrasse 43, 8004 Zurich, Switzerland



S Schweizerischer Kalibrierdienst
C Service suisse d'étalonnage
S Servizio svizzero di taratura
S Swiss Calibration Service

Accredited by the Swiss Accreditation Service (SAS)
The Swiss Accreditation Service is one of the signatories to the EA
Multilateral Agreement for the recognition of calibration certificates

Accreditation No.: **SCS 0108**

Client **Auden**

Certificate No: **D1750V2-1023_Jun18**

CALIBRATION CERTIFICATE

Object **D1750V2 - SN:1023**

Calibration procedure(s) **QA CAL-05.v10
Calibration procedure for dipole validation kits above 700 MHz**

Calibration date: **June 11, 2018**



This calibration certificate documents the traceability to national standards, which realize the physical units of measurements (SI).
The measurements and the uncertainties with confidence probability are given on the following pages and are part of the certificate.

All calibrations have been conducted in the closed laboratory facility: environment temperature (22 ± 3)°C and humidity < 70%.

Calibration Equipment used (M&TE critical for calibration)

Primary Standards	ID #	Cal Date (Certificate No.)	Scheduled Calibration
Power meter NRP	SN: 104778	04-Apr-18 (No. 217-02672/02673)	Apr-19
Power sensor NRP-Z91	SN: 103244	04-Apr-18 (No. 217-02672)	Apr-19
Power sensor NRP-Z91	SN: 103245	04-Apr-18 (No. 217-02673)	Apr-19
Reference 20 dB Attenuator	SN: 5058 (20k)	04-Apr-18 (No. 217-02682)	Apr-19
Type-N mismatch combination	SN: 5047.2 / 06327	04-Apr-18 (No. 217-02683)	Apr-19
Reference Probe EX3DV4	SN: 7349	30-Dec-17 (No. EX3-7349_Dec17)	Dec-18
DAE4	SN: 601	26-Oct-17 (No. DAE4-601_Oct17)	Oct-18

Secondary Standards	ID #	Check Date (in house)	Scheduled Check
Power meter EPM-442A	SN: GB37480704	07-Oct-15 (in house check Oct-16)	In house check: Oct-18
Power sensor HP 8481A	SN: US37292783	07-Oct-15 (in house check Oct-16)	In house check: Oct-18
Power sensor HP 8481A	SN: MY41092317	07-Oct-15 (in house check Oct-16)	In house check: Oct-18
RF generator R&S SMT-06	SN: 100972	15-Jun-15 (in house check Oct-16)	In house check: Oct-18
Network Analyzer HP 8753E	SN: US37390585	18-Oct-01 (in house check Oct-17)	In house check: Oct-18

Calibrated by:	Name Jeton Kastrati	Function Laboratory Technician	Signature 
Approved by:	Name Katja Pokovic	Function Technical Manager	Signature 

Issued: June 11, 2018

This calibration certificate shall not be reproduced except in full without written approval of the laboratory.

Calibration Laboratory of
Schmid & Partner
Engineering AG
Zeughausstrasse 43, 8004 Zurich, Switzerland



S Schweizerischer Kalibrierdienst
C Service suisse d'étalonnage
S Servizio svizzero di taratura
S Swiss Calibration Service

Accredited by the Swiss Accreditation Service (SAS)
The Swiss Accreditation Service is one of the signatories to the EA
Multilateral Agreement for the recognition of calibration certificates

Accreditation No.: **SCS 0108**

Glossary:

TSL tissue simulating liquid
ConvF sensitivity in TSL / NORM x,y,z
N/A not applicable or not measured

Calibration is Performed According to the Following Standards:

- a) IEEE Std 1528-2013, "IEEE Recommended Practice for Determining the Peak Spatial-Averaged Specific Absorption Rate (SAR) in the Human Head from Wireless Communications Devices: Measurement Techniques", June 2013
- b) IEC 62209-1, "Measurement procedure for the assessment of Specific Absorption Rate (SAR) from hand-held and body-mounted devices used next to the ear (frequency range of 300 MHz to 6 GHz)", July 2016
- c) IEC 62209-2, "Procedure to determine the Specific Absorption Rate (SAR) for wireless communication devices used in close proximity to the human body (frequency range of 30 MHz to 6 GHz)", March 2010
- d) KDB 865664, "SAR Measurement Requirements for 100 MHz to 6 GHz"

Additional Documentation:

- e) DASY4/5 System Handbook

Methods Applied and Interpretation of Parameters:

- *Measurement Conditions:* Further details are available from the Validation Report at the end of the certificate. All figures stated in the certificate are valid at the frequency indicated.
- *Antenna Parameters with TSL:* The dipole is mounted with the spacer to position its feed point exactly below the center marking of the flat phantom section, with the arms oriented parallel to the body axis.
- *Feed Point Impedance and Return Loss:* These parameters are measured with the dipole positioned under the liquid filled phantom. The impedance stated is transformed from the measurement at the SMA connector to the feed point. The Return Loss ensures low reflected power. No uncertainty required.
- *Electrical Delay:* One-way delay between the SMA connector and the antenna feed point. No uncertainty required.
- *SAR measured:* SAR measured at the stated antenna input power.
- *SAR normalized:* SAR as measured, normalized to an input power of 1 W at the antenna connector.
- *SAR for nominal TSL parameters:* The measured TSL parameters are used to calculate the nominal SAR result.

The reported uncertainty of measurement is stated as the standard uncertainty of measurement multiplied by the coverage factor $k=2$, which for a normal distribution corresponds to a coverage probability of approximately 95%.

Measurement Conditions

DASY system configuration, as far as not given on page 1.

DASY Version	DASY5	V52.10.1
Extrapolation	Advanced Extrapolation	
Phantom	Modular Flat Phantom	
Distance Dipole Center - TSL	10 mm	with Spacer
Zoom Scan Resolution	dx, dy, dz = 5 mm	
Frequency	1750 MHz \pm 1 MHz	

Head TSL parameters

The following parameters and calculations were applied.

	Temperature	Permittivity	Conductivity
Nominal Head TSL parameters	22.0 °C	40.1	1.37 mho/m
Measured Head TSL parameters	(22.0 \pm 0.2) °C	39.0 \pm 6 %	1.36 mho/m \pm 6 %
Head TSL temperature change during test	< 0.5 °C	----	----

SAR result with Head TSL

SAR averaged over 1 cm ³ (1 g) of Head TSL	Condition	
SAR measured	250 mW input power	9.10 W/kg
SAR for nominal Head TSL parameters	normalized to 1W	36.3 W/kg \pm 17.0 % (k=2)

SAR averaged over 10 cm ³ (10 g) of Head TSL	condition	
SAR measured	250 mW input power	4.82 W/kg
SAR for nominal Head TSL parameters	normalized to 1W	19.3 W/kg \pm 16.5 % (k=2)

Body TSL parameters

The following parameters and calculations were applied.

	Temperature	Permittivity	Conductivity
Nominal Body TSL parameters	22.0 °C	53.4	1.49 mho/m
Measured Body TSL parameters	(22.0 \pm 0.2) °C	53.6 \pm 6 %	1.47 mho/m \pm 6 %
Body TSL temperature change during test	< 0.5 °C	----	----

SAR result with Body TSL

SAR averaged over 1 cm ³ (1 g) of Body TSL	Condition	
SAR measured	250 mW input power	9.12 W/kg
SAR for nominal Body TSL parameters	normalized to 1W	36.8 W/kg \pm 17.0 % (k=2)

SAR averaged over 10 cm ³ (10 g) of Body TSL	condition	
SAR measured	250 mW input power	4.90 W/kg
SAR for nominal Body TSL parameters	normalized to 1W	19.7 W/kg \pm 16.5 % (k=2)



Appendix (Additional assessments outside the scope of SCS 0108)

Antenna Parameters with Head TSL

Impedance, transformed to feed point	51.0 Ω - 0.5 $j\Omega$
Return Loss	- 39.1 dB

Antenna Parameters with Body TSL

Impedance, transformed to feed point	46.0 Ω + 0.3 $j\Omega$
Return Loss	- 27.5 dB

General Antenna Parameters and Design

Electrical Delay (one direction)	1.217 ns
----------------------------------	----------

After long term use with 100W radiated power, only a slight warming of the dipole near the feedpoint can be measured.

The dipole is made of standard semirigid coaxial cable. The center conductor of the feeding line is directly connected to the second arm of the dipole. The antenna is therefore short-circuited for DC-signals. On some of the dipoles, small end caps are added to the dipole arms in order to improve matching when loaded according to the position as explained in the "Measurement Conditions" paragraph. The SAR data are not affected by this change. The overall dipole length is still according to the Standard.

No excessive force must be applied to the dipole arms, because they might bend or the soldered connections near the feedpoint may be damaged.

Additional EUT Data

Manufactured by	SPEAG
Manufactured on	August 20, 2009

DASY5 Validation Report for Head TSL

Date: 11.06.2018

Test Laboratory: SPEAG, Zurich, Switzerland

DUT: Dipole 1750 MHz; Type: D1750V2; Serial: D1750V2 - SN:1023

Communication System: UID 0 - CW; Frequency: 1750 MHz

Medium parameters used: $f = 1750$ MHz; $\sigma = 1.36$ S/m; $\epsilon_r = 39$; $\rho = 1000$ kg/m³

Phantom section: Flat Section

Measurement Standard: DASY5 (IEEE/IEC/ANSI C63.19-2011)

DASY52 Configuration:

- Probe: EX3DV4 - SN7349; ConvF(8.5, 8.5, 8.5) @ 1750 MHz; Calibrated: 30.12.2017
- Sensor-Surface: 1.4mm (Mechanical Surface Detection)
- Electronics: DAE4 Sn601; Calibrated: 26.10.2017
- Phantom: Flat Phantom 5.0 (front); Type: QD 000 P50 AA; Serial: 1001
- DASY52 52.10.1(1476); SEMCAD X 14.6.11(7439)

Dipole Calibration for Head Tissue/Pin=250 mW, d=10mm/Zoom Scan (7x7x7)/Cube 0:

Measurement grid: dx=5mm, dy=5mm, dz=5mm

Reference Value = 106.5 V/m; Power Drift = -0.05 dB

Peak SAR (extrapolated) = 16.5 W/kg

SAR(1 g) = 9.1 W/kg; SAR(10 g) = 4.82 W/kg

Maximum value of SAR (measured) = 14.0 W/kg

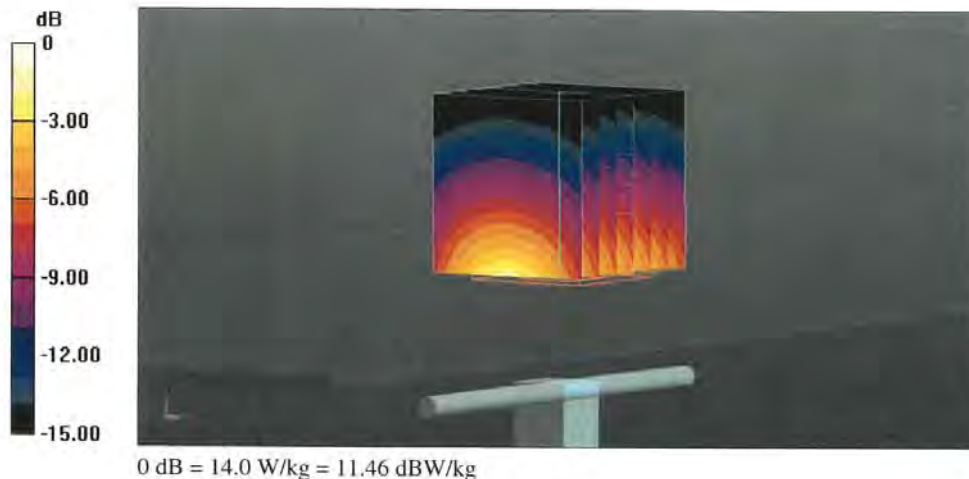



Impedance Measurement Plot for Head TSL

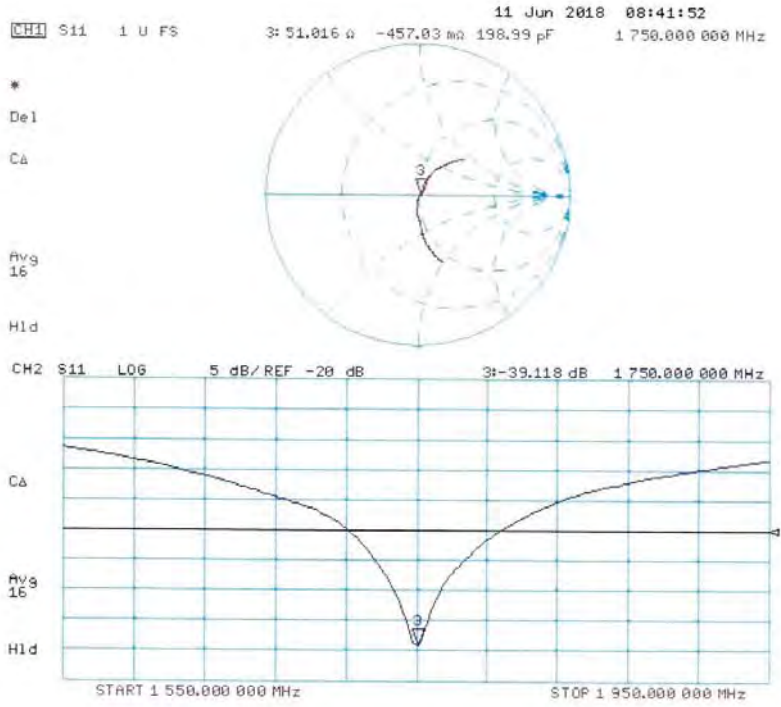

DASY5 Validation Report for Body TSL

Date: 11.06.2018

Test Laboratory: SPEAG, Zurich, Switzerland

DUT: Dipole 1750 MHz; Type: D1750V2; Serial: D1750V2 - SN:1023

Communication System: UID 0 - CW; Frequency: 1750 MHz

Medium parameters used: $f = 1750$ MHz; $\sigma = 1.47$ S/m; $\epsilon_r = 53.6$; $\rho = 1000$ kg/m³

Phantom section: Flat Section

Measurement Standard: DASY5 (IEEE/IEC/ANSI C63.19-2011)

DASY52 Configuration:

- Probe: EX3DV4 - SN7349; ConvF(8.35, 8.35, 8.35) @ 1750 MHz; Calibrated: 30.12.2017
- Sensor-Surface: 1.4mm (Mechanical Surface Detection)
- Electronics: DAE4 Sn601; Calibrated: 26.10.2017
- Phantom: Flat Phantom 5.0 (back); Type: QD 000 P50 AA; Serial: 1002
- DASY52 52.10.1(1476); SEMCAD X 14.6.11(7439)

Dipole Calibration for Body Tissue/Pin=250 mW, d=10mm/Zoom Scan (7x7x7)/Cube 0:

Measurement grid: dx=5mm, dy=5mm, dz=5mm

Reference Value = 102.3 V/m; Power Drift = -0.05 dB

Peak SAR (extrapolated) = 15.8 W/kg

SAR(1 g) = 9.12 W/kg; SAR(10 g) = 4.9 W/kg

Maximum value of SAR (measured) = 13.5 W/kg

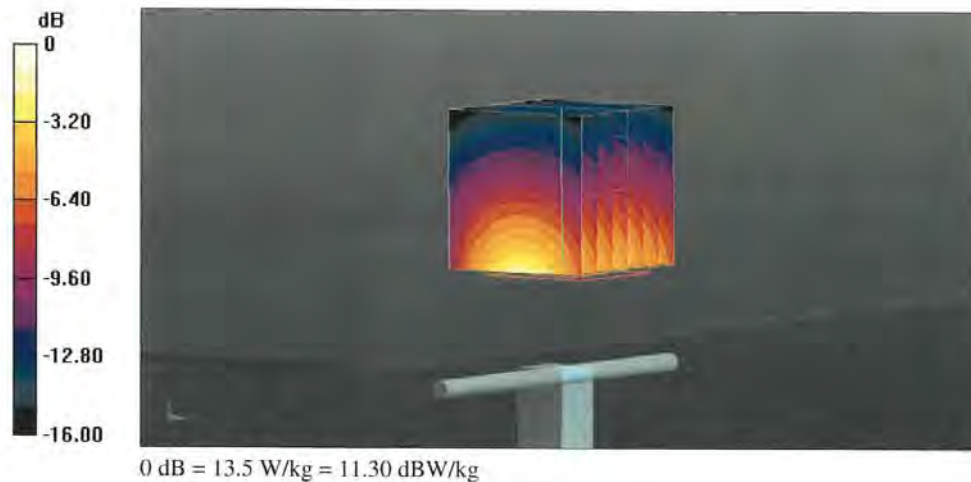



Impedance Measurement Plot for Body TSL

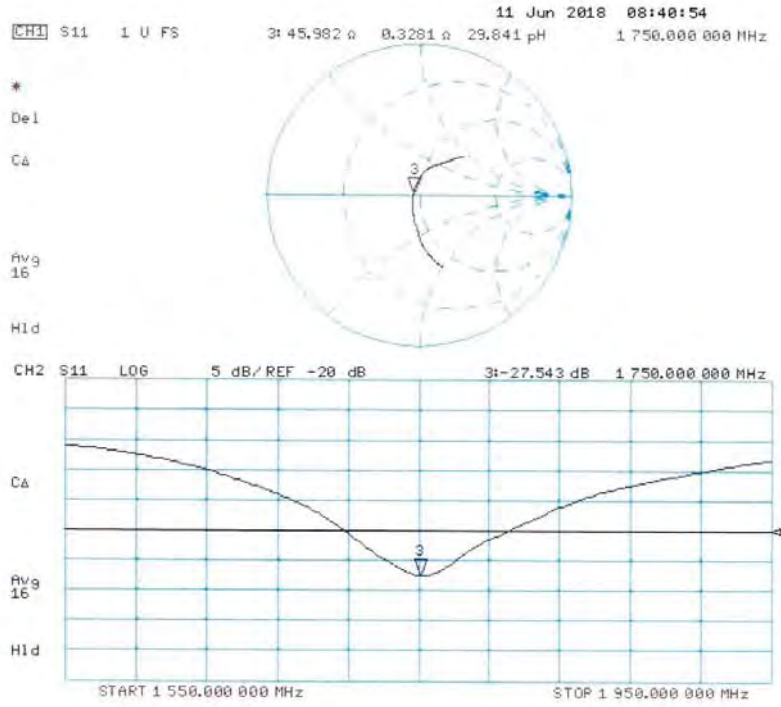



In Collaboration with
s p e a g
CALIBRATION LABORATORY

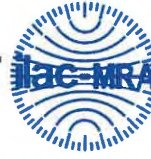

中国认可
国际互认
校准
CALIBRATION
CNAS L0570

ST-038-18-247

Add: No.51 Xueyuan Road, Haidian District, Beijing, 100191, China
Tel: +86-10-62304633-2079 Fax: +86-10-62304633-2504
E-mail: cttl@chinattl.com http://www.chinattl.cn

Client

ATL

Certificate No: Z18-60309

CALIBRATION CERTIFICATE

Object: D1900V2 - SN: 5d111

Calibration Procedure(s): FF-Z11-003-01
Calibration Procedures for dipole validation kits

Calibration date: September 11, 2018

This calibration Certificate documents the traceability to national standards, which realize the physical units of measurements(SI). The measurements and the uncertainties with confidence probability are given on the following pages and are part of the certificate.

All calibrations have been conducted in the closed laboratory facility: environment temperature(22±3)°C and humidity<70%.

Calibration Equipment used (M&TE critical for calibration)

Primary Standards	ID #	Cal Date(Calibrated by, Certificate No.)	Scheduled Calibration
Power Meter NRVD	102083	01-Nov-17 (CTTL, No.J17X08756)	Oct-18
Power sensor NRV-Z5	100542	01-Nov-17 (CTTL, No.J17X08756)	Oct-18
Reference Probe EX3DV4	SN 7464	12-Sep-17(SPEAG,No.EX3-7464_Sep17)	Sep-18
DAE4	SN 1524	13-Sep-17(SPEAG,No.DAE4-1524_Sep17)	Sep-18
Secondary Standards	ID #	Cal Date(Calibrated by, Certificate No.)	Scheduled Calibration
Signal Generator E4438C	MY49071430	23-Jan-18 (CTTL, No.J18X00560)	Jan-19
NetworkAnalyzer E5071C	MY46110673	24-Jan-18 (CTTL, No.J18X00561)	Jan-19

	Name	Function	Signature
Calibrated by:	Zhao Jing	SAR Test Engineer	
Reviewed by:	Lin Jun	SAR Test Engineer	
Approved by:	Qi Dianyuan	SAR Project Leader	

Issued: September 15, 2018

This calibration certificate shall not be reproduced except in full without written approval of the laboratory.

lossary:

TSL	tissue simulating liquid
ConvF	sensitivity in TSL / NORM _{x,y,z}
N/A	not applicable or not measured

Calibration is Performed According to the Following Standards:

- IEEE Std 1528-2013, "IEEE Recommended Practice for Determining the Peak Spatial-Averaged Specific Absorption Rate (SAR) in the Human Head from Wireless Communications Devices: Measurement Techniques", June 2013
- IEC 62209-1, "Measurement procedure for assessment of specific absorption rate of human exposure to radio frequency fields from hand-held and body-mounted wireless communication devices- Part 1: Device used next to the ear (Frequency range of 300MHz to 6GHz)", July 2016
- IEC 62209-2, "Procedure to measure the Specific Absorption Rate (SAR) For wireless communication devices used in close proximity to the human body (frequency range of 30MHz to 6GHz)", March 2010
- KDB865664, SAR Measurement Requirements for 100 MHz to 6 GHz

Additional Documentation:

- DASY4/5 System Handbook

Methods Applied and Interpretation of Parameters:

- Measurement Conditions:* Further details are available from the Validation Report at the end of the certificate. All figures stated in the certificate are valid at the frequency indicated.
- Antenna Parameters with TSL:* The dipole is mounted with the spacer to position its feed point exactly below the center marking of the flat phantom section, with the arms oriented parallel to the body axis.
- Feed Point Impedance and Return Loss:* These parameters are measured with the dipole positioned under the liquid filled phantom. The impedance stated is transformed from the measurement at the SMA connector to the feed point. The Return Loss ensures low reflected power. No uncertainty required.
- Electrical Delay:* One-way delay between the SMA connector and the antenna feed point. No uncertainty required.
- SAR measured:* SAR measured at the stated antenna input power.
- SAR normalized:* SAR as measured, normalized to an input power of 1 W at the antenna connector.
- SAR for nominal TSL parameters:* The measured TSL parameters are used to calculate the nominal SAR result.

The reported uncertainty of measurement is stated as the standard uncertainty of Measurement multiplied by the coverage factor $k=2$, which for a normal distribution Corresponds to a coverage probability of approximately 95%.

Measurement Conditions

DASY system configuration, as far as not given on page 1.

DASY Version	DASY52	52.10.1.1476
Extrapolation	Advanced Extrapolation	
Phantom	Triple Flat Phantom 5.1C	
Distance Dipole Center - TSL	10 mm	with Spacer
Zoom Scan Resolution	dx, dy, dz = 5 mm	
Frequency	1900 MHz \pm 1 MHz	

Head TSL parameters

The following parameters and calculations were applied.

	Temperature	Permittivity	Conductivity
Nominal Head TSL parameters	22.0 °C	40.0	1.40 mho/m
Measured Head TSL parameters	(22.0 \pm 0.2) °C	40.4 \pm 6 %	1.44 mho/m \pm 6 %
Head TSL temperature change during test	<1.0 °C	----	----

SAR result with Head TSL

SAR averaged over 1 cm^3 (1 g) of Head TSL	Condition	
SAR measured	250 mW input power	10.1 mW / g
SAR for nominal Head TSL parameters	normalized to 1W	39.8 mW / g \pm 18.8 % (k=2)
SAR averaged over 10 cm^3 (10 g) of Head TSL	Condition	
SAR measured	250 mW input power	5.33 mW / g
SAR for nominal Head TSL parameters	normalized to 1W	21.1 mW / g \pm 18.7 % (k=2)

Body TSL parameters

The following parameters and calculations were applied.

	Temperature	Permittivity	Conductivity
Nominal Body TSL parameters	22.0 °C	53.3	1.52 mho/m
Measured Body TSL parameters	(22.0 \pm 0.2) °C	53.3 \pm 6 %	1.49 mho/m \pm 6 %
Body TSL temperature change during test	<1.0 °C	----	----

SAR result with Body TSL

SAR averaged over 1 cm^3 (1 g) of Body TSL	Condition	
SAR measured	250 mW input power	9.99 mW / g
SAR for nominal Body TSL parameters	normalized to 1W	40.4 mW / g \pm 18.8 % (k=2)
SAR averaged over 10 cm^3 (10 g) of Body TSL	Condition	
SAR measured	250 mW input power	5.41 mW / g
SAR for nominal Body TSL parameters	normalized to 1W	21.8 mW / g \pm 18.7 % (k=2)

Appendix (Additional assessments outside the scope of CNAS L0570)

Antenna Parameters with Head TSL

Impedance, transformed to feed point	51.6Ω+ 6.78jΩ
Return Loss	- 23.3dB

Antenna Parameters with Body TSL

Impedance, transformed to feed point	46.3Ω+ 6.22jΩ
Return Loss	- 22.5dB

General Antenna Parameters and Design

Electrical Delay (one direction)	1.066 ns
----------------------------------	----------

After long term use with 100W radiated power, only a slight warming of the dipole near the feedpoint can be measured.

The dipole is made of standard semirigid coaxial cable. The center conductor of the feeding line is directly connected to the second arm of the dipole. The antenna is therefore short-circuited for DC-signals. On some of the dipoles, small end caps are added to the dipole arms in order to improve matching when loaded according to the position as explained in the "Measurement Conditions" paragraph. The SAR data are not affected by this change. The overall dipole length is still according to the Standard.

No excessive force must be applied to the dipole arms, because they might bend or the soldered connections near the feedpoint may be damaged.

Additional EUT Data

Manufactured by	SPEAG
-----------------	-------

DASY5 Validation Report for Head TSL

Date: 09.10.2018

Test Laboratory: CTTL, Beijing, China

DUT: Dipole 1900 MHz; Type: D1900V2; Serial: D1900V2 - SN: 5d111

Communication System: UID 0, CW; Frequency: 1900 MHz; Duty Cycle: 1:1

Medium parameters used: $f = 1900$ MHz; $\sigma = 1.438$ S/m; $\epsilon_r = 40.37$; $\rho = 1000$ kg/m³

Phantom section: Center Section

DASY5 Configuration:

- Probe: EX3DV4 - SN7464; ConvF(8.39, 8.39, 8.39) @ 1900 MHz; Calibrated: 9/12/2017
- Sensor-Surface: 1.4mm (Mechanical Surface Detection)
- Electronics: DAE4 Sn1524; Calibrated: 9/13/2017
- Phantom: MFP_V5.1C ; Type: QD 000 P51CA; Serial: 1062
- Measurement SW: DASY52, Version 52.10 (1); SEMCAD X Version 14.6.11 (7439)

System Performance Check/Zoom Scan (7x7x7) (7x7x7)/Cube 0: Measurement grid:

$dx=5$ mm, $dy=5$ mm, $dz=5$ mm

Reference Value = 95.90 V/m; Power Drift = -0.01 dB

Peak SAR (extrapolated) = 19.0 W/kg

SAR(1 g) = 10.1 W/kg; SAR(10 g) = 5.33 W/kg

Maximum value of SAR (measured) = 15.8 W/kg

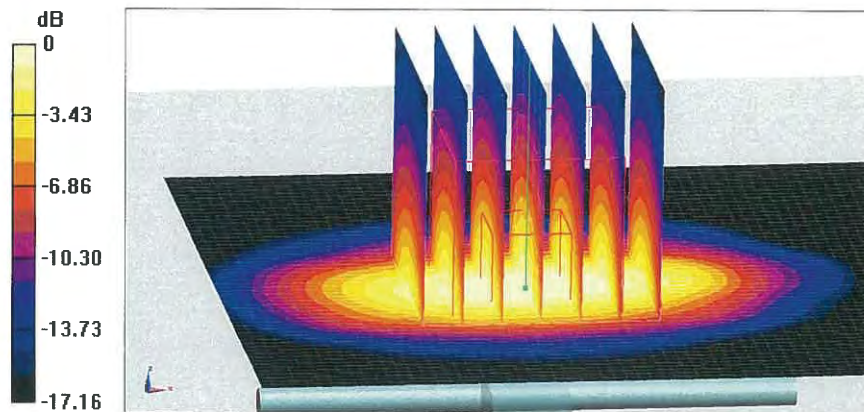

0 dB = 15.8 W/kg = 11.99 dBW/kg

Impedance Measurement Plot for Head TSL

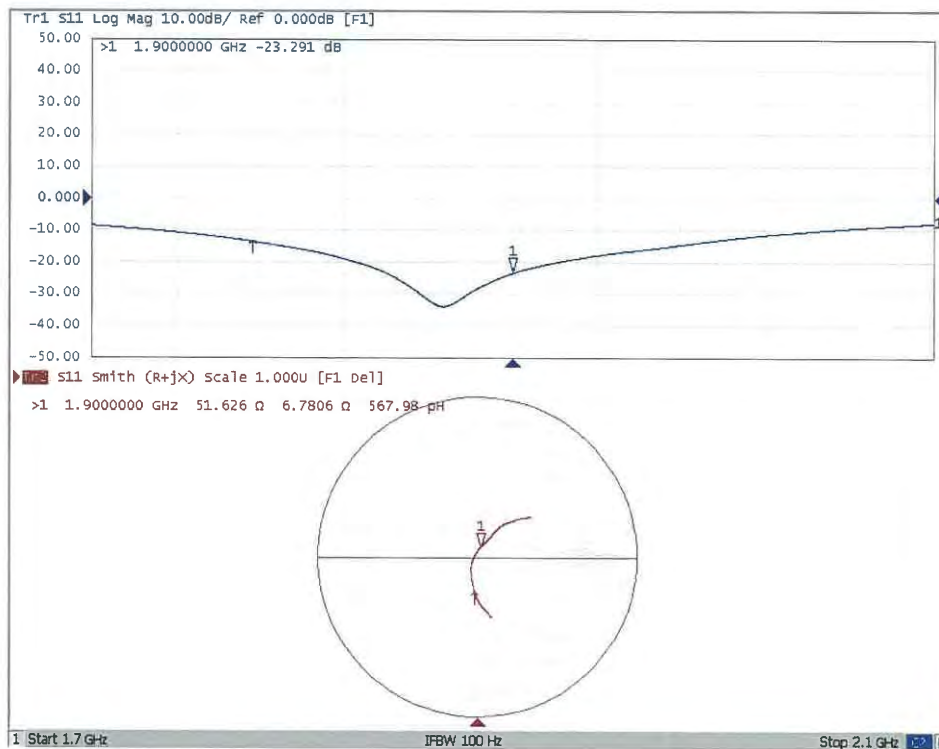

DASY5 Validation Report for Body TSL

Date: 09.10.2018

Test Laboratory: CTTL, Beijing, China

DUT: Dipole 1900 MHz; Type: D1900V2; Serial: D1900V2 - SN: 5d111

Communication System: UID 0, CW; Frequency: 1900 MHz; Duty Cycle: 1:1

Medium parameters used: $f = 1900$ MHz; $\sigma = 1.493$ S/m; $\epsilon_r = 53.34$; $\rho = 1000$ kg/m³

Phantom section: Right Section

DASY5 Configuration:

- Probe: EX3DV4 - SN7464; ConvF(8.32, 8.32, 8.32) @ 1900 MHz; Calibrated: 9/12/2017
- Sensor-Surface: 1.4mm (Mechanical Surface Detection)
- Electronics: DAE4 Sn1524; Calibrated: 9/13/2017
- Phantom: MFP_V5.1C ; Type: QD 000 P51CA; Serial: 1062
- Measurement SW: DASY52, Version 52.10 (1); SEMCAD X Version 14.6.11 (7439)

System Performance Check/Zoom Scan (7x7x7) (7x7x7)/Cube 0: Measurement grid:

$dx=5$ mm, $dy=5$ mm, $dz=5$ mm

Reference Value = 96.64 V/m; Power Drift = -0.04 dB

Peak SAR (extrapolated) = 17.6 W/kg

SAR(1 g) = 9.99 W/kg; SAR(10 g) = 5.41 W/kg

Maximum value of SAR (measured) = 15.0 W/kg

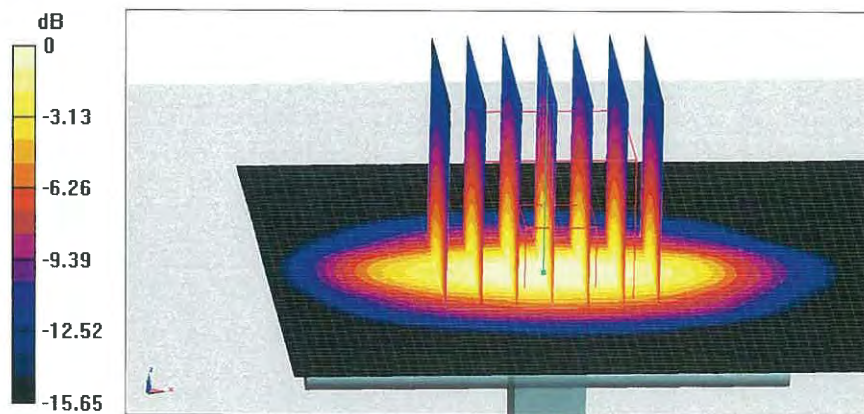

0 dB = 15.0 W/kg = 11.76 dBW/kg

Impedance Measurement Plot for Body TSL

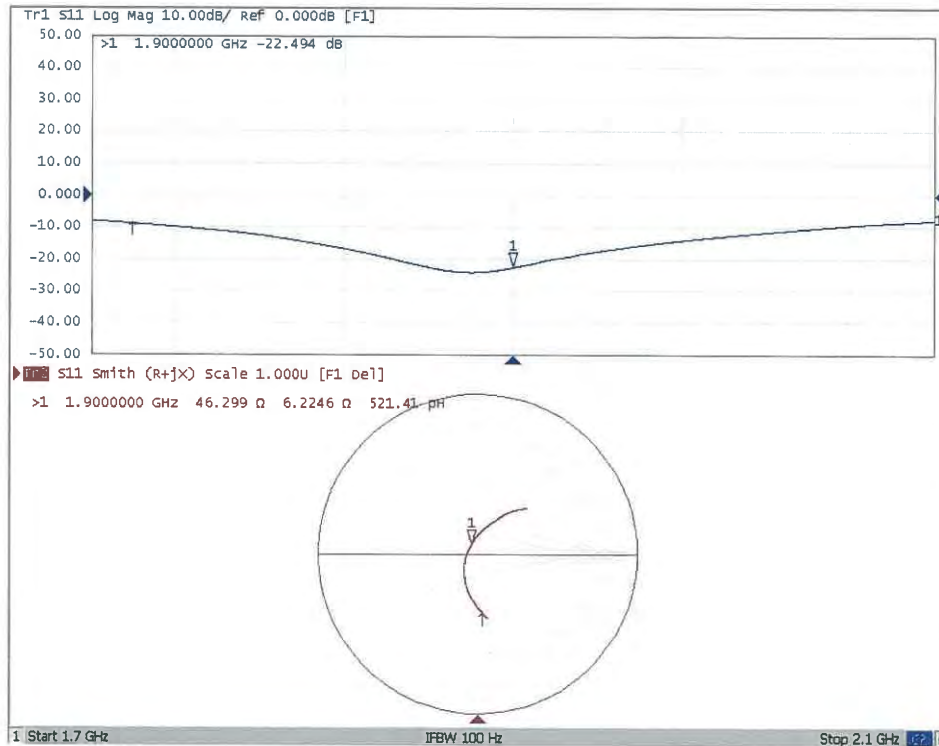



ST-60Z-18-12



In Collaboration with
s p e a g
CALIBRATION LABORATORY



中国认可
国际互认
校准
CALIBRATION
CNAS L0570

Add: No.51 Xueyuan Road, Haidian District, Beijing, 100191, China
Tel: +86-10-62304633-2079 Fax: +86-10-62304633-2504
E-mail: cttl@chinattl.com http://www.chinattl.cn

Client **ATL**

Certificate No: **Z18-60066**

CALIBRATION CERTIFICATE

Object: D2450V2 - SN: 712

Calibration Procedure(s): FF-Z11-003-01
Calibration Procedures for dipole validation kits

Calibration date: April 9, 2018

This calibration Certificate documents the traceability to national standards, which realize the physical units of measurements(SI). The measurements and the uncertainties with confidence probability are given on the following pages and are part of the certificate.

All calibrations have been conducted in the closed laboratory facility: environment temperature(22±3)°C and humidity<70%.

Calibration Equipment used (M&TE critical for calibration)

Primary Standards	ID #	Cal Date(Calibrated by, Certificate No.)	Scheduled Calibration
Power Meter NRVD	102083	01-Nov-17 (CTTL, No.J17X08756)	Oct-18
Power sensor NRV-Z5	100542	01-Nov-17 (CTTL, No.J17X08756)	Oct-18
Reference Probe EX3DV4	SN 7464	12-Sep-17(SPEAG,No.EX3-7464_Sep17)	Sep-18
DAE4	SN 1525	02-Oct-17(SPEAG,No.DAE4-1525_Oct17)	Oct-18
Secondary Standards	ID #	Cal Date(Calibrated by, Certificate No.)	Scheduled Calibration
Signal Generator E4438C	MY49071430	23-Jan-18 (CTTL, No.J18X00560)	Jan-19
NetworkAnalyzer E5071C	MY46110673	24-Jan-18 (CTTL, No.J18X00561)	Jan-19

	Name	Function	Signature
Calibrated by:	Zhao Jing	SAR Test Engineer	
Reviewed by:	Lin Hao	SAR Test Engineer	
Approved by:	Qi Dianyuan	SAR Project Leader	

Issued: April 12, 2018

This calibration certificate shall not be reproduced except in full without written approval of the laboratory.

Certificate No: Z18-60066

Page 1 of 8



In Collaboration with
s p e a g
CALIBRATION LABORATORY

Add: No.51 Xueyuan Road, Haidian District, Beijing, 100191, China
Tel: +86-10-62304633-2079 Fax: +86-10-62304633-2504
E-mail: cttl@chinattl.com http://www.chinattl.cn

Glossary:

TSL	tissue simulating liquid
ConvF	sensitivity in TSL / NORM _{x,y,z}
N/A	not applicable or not measured

Calibration is Performed According to the Following Standards:

- IEEE Std 1528-2013, "IEEE Recommended Practice for Determining the Peak Spatial-Averaged Specific Absorption Rate (SAR) in the Human Head from Wireless Communications Devices: Measurement Techniques", June 2013
- IEC 62209-1, "Measurement procedure for assessment of specific absorption rate of human exposure to radio frequency fields from hand-held and body-mounted wireless communication devices- Part 1: Device used next to the ear (Frequency range of 300MHz to 6GHz)", July 2016
- IEC 62209-2, "Procedure to measure the Specific Absorption Rate (SAR) For wireless communication devices used in close proximity to the human body (frequency range of 30MHz to 6GHz)", March 2010
- KDB865664, SAR Measurement Requirements for 100 MHz to 6 GHz

Additional Documentation:

- DASY4/5 System Handbook

Methods Applied and Interpretation of Parameters:

- Measurement Conditions:** Further details are available from the Validation Report at the end of the certificate. All figures stated in the certificate are valid at the frequency indicated.
- Antenna Parameters with TSL:** The dipole is mounted with the spacer to position its feed point exactly below the center marking of the flat phantom section, with the arms oriented parallel to the body axis.
- Feed Point Impedance and Return Loss:** These parameters are measured with the dipole positioned under the liquid filled phantom. The impedance stated is transformed from the measurement at the SMA connector to the feed point. The Return Loss ensures low reflected power. No uncertainty required.
- Electrical Delay:** One-way delay between the SMA connector and the antenna feed point. No uncertainty required.
- SAR measured:** SAR measured at the stated antenna input power.
- SAR normalized:** SAR as measured, normalized to an input power of 1 W at the antenna connector.
- SAR for nominal TSL parameters:** The measured TSL parameters are used to calculate the nominal SAR result.

The reported uncertainty of measurement is stated as the standard uncertainty of Measurement multiplied by the coverage factor $k=2$, which for a normal distribution corresponds to a coverage probability of approximately 95%.



Measurement Conditions

DASY system configuration, as far as not given on page 1.

DASY Version	DASY52	52.10.0.1446
Extrapolation	Advanced Extrapolation	
Phantom	Triple Flat Phantom 5.1C	
Distance Dipole Center - TSL	10 mm	with Spacer
Zoom Scan Resolution	dx, dy, dz = 5 mm	
Frequency	2450 MHz \pm 1 MHz	

Head TSL parameters

The following parameters and calculations were applied.

	Temperature	Permittivity	Conductivity
Nominal Head TSL parameters	22.0 °C	39.2	1.80 mho/m
Measured Head TSL parameters	(22.0 \pm 0.2) °C	40.3 \pm 6 %	1.85 mho/m \pm 6 %
Head TSL temperature change during test	<1.0 °C	----	----

SAR result with Head TSL

SAR averaged over 1 cm^3 (1 g) of Head TSL	Condition	
SAR measured	250 mW input power	13.5 mW / g
SAR for nominal Head TSL parameters	normalized to 1W	53.6 mW / g \pm 18.8 % (k=2)
SAR averaged over 10 cm^3 (10 g) of Head TSL	Condition	
SAR measured	250 mW input power	6.14 mW / g
SAR for nominal Head TSL parameters	normalized to 1W	24.5 mW / g \pm 18.7 % (k=2)

Body TSL parameters

The following parameters and calculations were applied.

	Temperature	Permittivity	Conductivity
Nominal Body TSL parameters	22.0 °C	52.7	1.95 mho/m
Measured Body TSL parameters	(22.0 \pm 0.2) °C	54.2 \pm 6 %	1.99 mho/m \pm 6 %
Body TSL temperature change during test	<1.0 °C	----	----

SAR result with Body TSL

SAR averaged over 1 cm^3 (1 g) of Body TSL	Condition	
SAR measured	250 mW input power	12.9 mW / g
SAR for nominal Body TSL parameters	normalized to 1W	51.4 mW / g \pm 18.8 % (k=2)
SAR averaged over 10 cm^3 (10 g) of Body TSL	Condition	
SAR measured	250 mW input power	5.99 mW / g
SAR for nominal Body TSL parameters	normalized to 1W	23.9 mW / g \pm 18.7 % (k=2)



In Collaboration with
s p e a g
 CALIBRATION LABORATORY

Add: No.51 Xueyuan Road, Haidian District, Beijing, 100191, China
 Tel: +86-10-62304633-2079 Fax: +86-10-62304633-2504
 E-mail: cttl@chinattl.com http://www.chinattl.cn

Appendix (Additional assessments outside the scope of CNAS L0570)

Antenna Parameters with Head TSL

Impedance, transformed to feed point	52.9Ω+ 3.91jΩ
Return Loss	- 26.6dB

Antenna Parameters with Body TSL

Impedance, transformed to feed point	48.9Ω+ 5.92jΩ
Return Loss	- 24.3dB

General Antenna Parameters and Design

Electrical Delay (one direction)	1.020 ns
----------------------------------	----------

After long term use with 100W radiated power, only a slight warming of the dipole near the feedpoint can be measured.

The dipole is made of standard semirigid coaxial cable. The center conductor of the feeding line is directly connected to the second arm of the dipole. The antenna is therefore short-circuited for DC-signals. On some of the dipoles, small end caps are added to the dipole arms in order to improve matching when loaded according to the position as explained in the "Measurement Conditions" paragraph. The SAR data are not affected by this change. The overall dipole length is still according to the Standard. No excessive force must be applied to the dipole arms, because they might bend or the soldered connections near the feedpoint may be damaged.

Additional EUT Data

Manufactured by	SPEAG
-----------------	-------

DASY5 Validation Report for Head TSL

Date: 04.08.2018

Test Laboratory: CTTL, Beijing, China

DUT: Dipole 2450 MHz; Type: D2450V2; Serial: D2450V2 - SN: 712

Communication System: UID 0, CW; Frequency: 2450 MHz; Duty Cycle: 1:1

Medium parameters used: $f = 2450$ MHz; $\sigma = 1.853$ S/m; $\epsilon_r = 40.34$; $\rho = 1000$ kg/m³

Phantom section: Right Section

Measurement Standard: DASY5 (IEEE/IEC/ANSI C63.19-2007)

DASY5 Configuration:

- Probe: EX3DV4 - SN7464; ConvF(7.89, 7.89, 7.89); Calibrated: 9/12/2017;
- Sensor-Surface: 1.4mm (Mechanical Surface Detection)
- Electronics: DAE4 Sn1525; Calibrated: 10/2/2017
- Phantom: Triple Flat Phantom 5.1C; Type: QD 000 P51 CA; Serial: 1161/1
- Measurement SW: DASY52, Version 52.10 (0); SEMCAD X Version 14.6.10 (7417)

Dipole Calibration/Zoom Scan (7x7x7) (7x7x7)/Cube 0: Measurement grid: dx=5mm, dy=5mm, dz=5mm

Reference Value = 109.0 V/m; Power Drift = -0.07 dB

Peak SAR (extrapolated) = 28.9W/kg

SAR(1 g) = 13.5 W/kg; SAR(10 g) = 6.14 W/kg

Maximum value of SAR (measured) = 23.1 W/kg

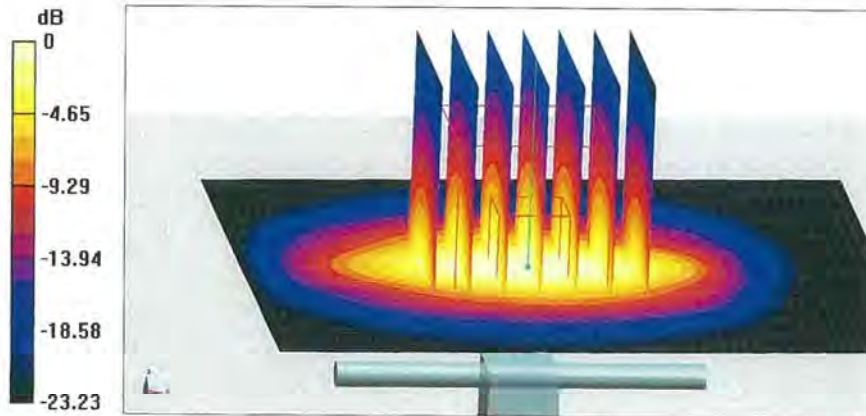

0 dB = 23.1 W/kg = 13.64 dBW/kg



In Collaboration with
s p e a g
CALIBRATION LABORATORY

Add: No.51 Xueyuan Road, Haidian District, Beijing, 100191, China
Tel: +86-10-62304633-2079 Fax: +86-10-62304633-2504
E-mail: cttl@chinattl.com http://www.chinattl.cn

Impedance Measurement Plot for Head TSL

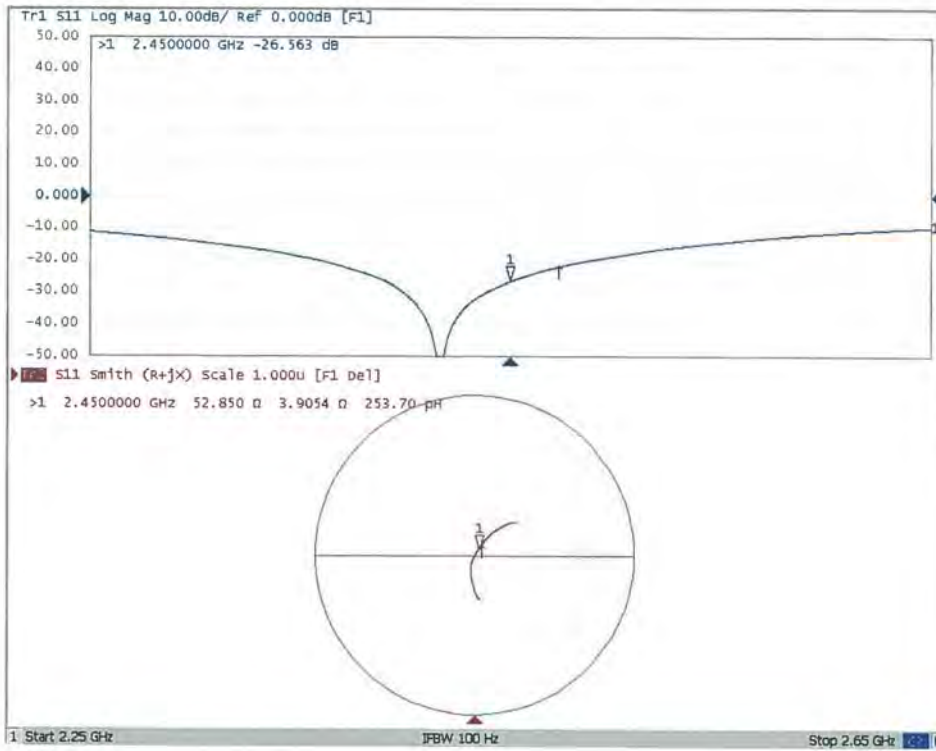

DASY5 Validation Report for Body TSL

Date: 04.09.2018

Test Laboratory: CTTL, Beijing, China

DUT: Dipole 2450 MHz; Type: D2450V2; Serial: D2450V2 - SN: 712

Communication System: UID 0, CW; Frequency: 2450 MHz; Duty Cycle: 1:1

Medium parameters used: $f = 2450$ MHz; $\sigma = 1.991$ S/m; $\epsilon_r = 54.17$; $\rho = 1000$ kg/m³

Phantom section: Left Section

Measurement Standard: DASY5 (IEEE/IEC/ANSI C63.19-2007)

DASY5 Configuration:

- Probe: EX3DV4 - SN7464; ConvF(8.09, 8.09, 8.09); Calibrated: 9/12/2017;
- Sensor-Surface: 1.4mm (Mechanical Surface Detection)
- Electronics: DAE4 Sn1525; Calibrated: 10/2/2017
- Phantom: Triple Flat Phantom 5.1C; Type: QD 000 P51 CA; Serial: 1161/1
- Measurement SW: DASY52, Version 52.10 (0); SEMCAD X Version 14.6.10 (7417)

Dipole Calibration/Zoom Scan (7x7x7) (7x7x7)/Cube 0: Measurement grid: dx=5mm, dy=5mm, dz=5mm

Reference Value = 100.9 V/m; Power Drift = 0.01 dB

Peak SAR (extrapolated) = 26.5 W/kg

SAR(1 g) = 12.9 W/kg; SAR(10 g) = 5.99 W/kg

Maximum value of SAR (measured) = 21.6 W/kg

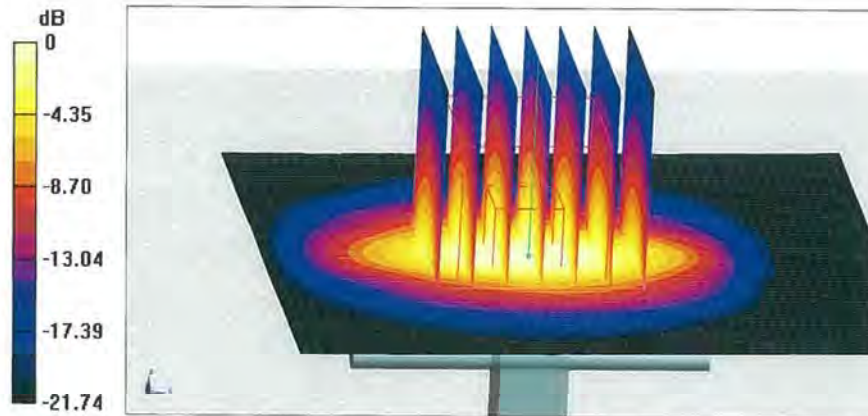

0 dB = 21.6 W/kg = 13.34 dBW/kg



In Collaboration with
s p e a g
CALIBRATION LABORATORY

Add: No.51 Xueyuan Road, Haidian District, Beijing, 100191, China
Tel: +86-10-62304633-2079 Fax: +86-10-62304633-2504
E-mail: cttl@chinattl.com http://www.chinattl.cn

Impedance Measurement Plot for Body TSL

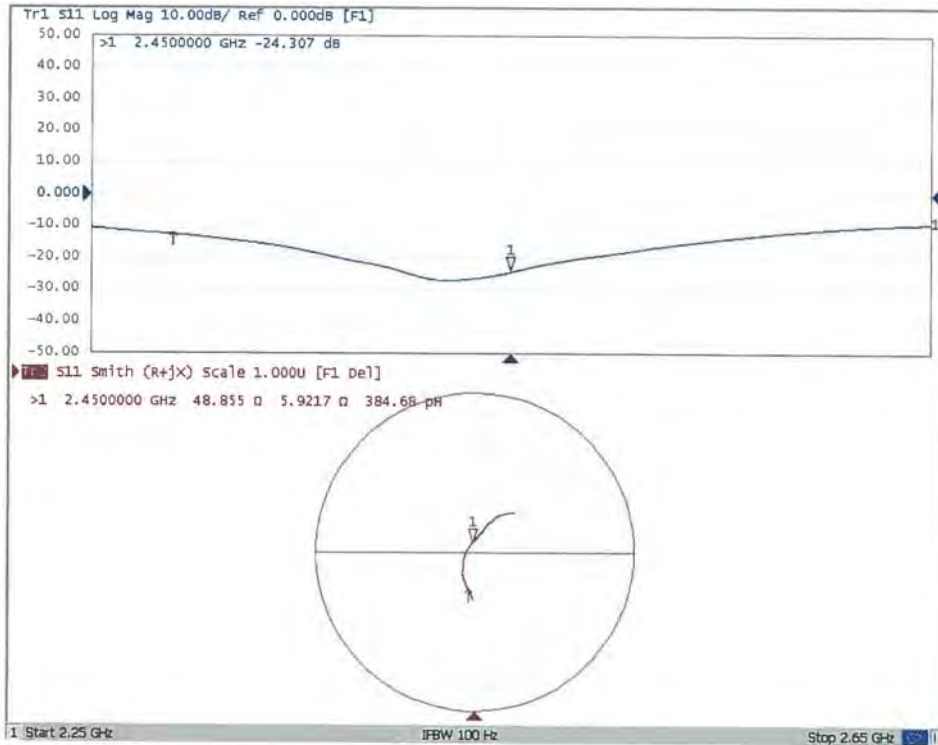

EX-042-18-117

**Calibration Laboratory of
Schmid & Partner
Engineering AG**
Zeughausstrasse 43, 8004 Zurich, Switzerland



S Schweizerischer Kalibrierdienst
C Service suisse d'étalonnage
S Servizio svizzero di taratura
S Swiss Calibration Service

Accredited by the Swiss Accreditation Service (SAS)
The Swiss Accreditation Service is one of the signatories to the EA
Multilateral Agreement for the recognition of calibration certificates

Accreditation No.: **SCS 0108**

Client **ATL (Auden)**

Certificate No: **EX3-3847_Apr18**

CALIBRATION CERTIFICATE

Object: **EX3DV4 - SN:3847**

Calibration procedure(s): **QA CAL-01.v9, QA CAL-12.v9, QA CAL-14.v4, QA CAL-23.v5,
QA CAL-25.v6
Calibration procedure for dosimetric E-field probes**



Calibration date: **April 26, 2018**

This calibration certificate documents the traceability to national standards, which realize the physical units of measurements (SI).
The measurements and the uncertainties with confidence probability are given on the following pages and are part of the certificate.

All calibrations have been conducted in the closed laboratory facility: environment temperature (22 ± 3)°C and humidity < 70%.

Calibration Equipment used (M&TE critical for calibration)

Primary Standards	ID	Cal Date (Certificate No.)	Scheduled Calibration
Power meter NRP	SN: 104778	04-Apr-18 (No. 217-02672/02673)	Apr-19
Power sensor NRP-Z91	SN: 103244	04-Apr-18 (No. 217-02672)	Apr-19
Power sensor NRP-Z91	SN: 103245	04-Apr-18 (No. 217-02673)	Apr-19
Reference 20 dB Attenuator	SN: S5277 (20x)	04-Apr-18 (No. 217-02682)	Apr-19
Reference Probe ES3DV2	SN: 3013	30-Dec-17 (No. ES3-3013_Dec17)	Dec-18
DAE4	SN: 660	21-Dec-17 (No. DAE4-660_Dec17)	Dec-18
Secondary Standards	ID	Check Date (in house)	Scheduled Check
Power meter E4419B	SN: GB41293874	06-Apr-16 (in house check Jun-16)	In house check: Jun-18
Power sensor E4412A	SN: MY41498087	06-Apr-16 (in house check Jun-16)	In house check: Jun-18
Power sensor E4412A	SN: 000110210	06-Apr-16 (in house check Jun-16)	In house check: Jun-18
RF generator HP 8648C	SN: US3642U01700	04-Aug-99 (in house check Jun-16)	In house check: Jun-18
Network Analyzer HP 8753E	SN: US37390585	18-Oct-01 (in house check Oct-17)	In house check: Oct-18

	Name	Function	Signature
Calibrated by:	Jeton Kastrati	Laboratory Technician	
Approved by:	Katja Pokovic	Technical Manager	

Issued: April 28, 2018

This calibration certificate shall not be reproduced except in full without written approval of the laboratory.

**Calibration Laboratory of
Schmid & Partner
Engineering AG**
Zeughausstrasse 43, 8004 Zurich, Switzerland



S Schweizerischer Kalibrierdienst
S Service suisse d'étalonnage
S Servizio svizzero di taratura
S Swiss Calibration Service

Accredited by the Swiss Accreditation Service (SAS)
The Swiss Accreditation Service is one of the signatories to the EA
Multilateral Agreement for the recognition of calibration certificates

Accreditation No.: **SCS 0108**

Glossary:

TSL	tissue simulating liquid
NORM _{x,y,z}	sensitivity in free space
ConvF	sensitivity in TSL / NORM _{x,y,z}
DCP	diode compression point
CF	crest factor (1/duty_cycle) of the RF signal
A, B, C, D	modulation dependent linearization parameters
Polarization φ	φ rotation around probe axis
Polarization ϑ	ϑ rotation around an axis that is in the plane normal to probe axis (at measurement center), i.e., $\vartheta = 0$ is normal to probe axis
Connector Angle	information used in DASY system to align probe sensor X to the robot coordinate system

Calibration is Performed According to the Following Standards:

- a) IEEE Std 1528-2013, "IEEE Recommended Practice for Determining the Peak Spatial-Averaged Specific Absorption Rate (SAR) in the Human Head from Wireless Communications Devices: Measurement Techniques", June 2013
- b) IEC 62209-1, "Measurement procedure for the assessment of Specific Absorption Rate (SAR) from hand-held and body-mounted devices used next to the ear (frequency range of 300 MHz to 6 GHz)", July 2016
- c) IEC 62209-2, "Procedure to determine the Specific Absorption Rate (SAR) for wireless communication devices used in close proximity to the human body (frequency range of 30 MHz to 6 GHz)", March 2010
- d) KDB 865664, "SAR Measurement Requirements for 100 MHz to 6 GHz"

Methods Applied and Interpretation of Parameters:

- **NORM_{x,y,z}**: Assessed for E-field polarization $\vartheta = 0$ ($f \leq 900$ MHz in TEM-cell; $f > 1800$ MHz: R22 waveguide). NORM_{x,y,z} are only intermediate values, i.e., the uncertainties of NORM_{x,y,z} does not affect the E²-field uncertainty inside TSL (see below ConvF).
- **NORM(f)_{x,y,z} = NORM_{x,y,z} * frequency_response** (see Frequency Response Chart). This linearization is implemented in DASY4 software versions later than 4.2. The uncertainty of the frequency response is included in the stated uncertainty of ConvF.
- **DCP_{x,y,z}**: DCP are numerical linearization parameters assessed based on the data of power sweep with CW signal (no uncertainty required). DCP does not depend on frequency nor media.
- **PAR**: PAR is the Peak to Average Ratio that is not calibrated but determined based on the signal characteristics
- **A_{x,y,z}; B_{x,y,z}; C_{x,y,z}; D_{x,y,z}; VR_{x,y,z}**: A, B, C, D are numerical linearization parameters assessed based on the data of power sweep for specific modulation signal. The parameters do not depend on frequency nor media. VR is the maximum calibration range expressed in RMS voltage across the diode.
- **ConvF and Boundary Effect Parameters**: Assessed in flat phantom using E-field (or Temperature Transfer Standard for $f \leq 800$ MHz) and inside waveguide using analytical field distributions based on power measurements for $f > 800$ MHz. The same setups are used for assessment of the parameters applied for boundary compensation (alpha, depth) of which typical uncertainty values are given. These parameters are used in DASY4 software to improve probe accuracy close to the boundary. The sensitivity in TSL corresponds to NORM_{x,y,z} * ConvF whereby the uncertainty corresponds to that given for ConvF. A frequency dependent ConvF is used in DASY version 4.4 and higher which allows extending the validity from ± 50 MHz to ± 100 MHz.
- **Spherical isotropy (3D deviation from isotropy)**: in a field of low gradients realized using a flat phantom exposed by a patch antenna.
- **Sensor Offset**: The sensor offset corresponds to the offset of virtual measurement center from the probe tip (on probe axis). No tolerance required.
- **Connector Angle**: The angle is assessed using the information gained by determining the NORM_x (no uncertainty required).



EX3DV4 – SN:3847

April 26, 2018

Probe EX3DV4

SN:3847

Manufactured: October 25, 2011
Calibrated: April 26, 2018

Calibrated for DASY/EASY Systems
(Note: non-compatible with DASY2 system!)



EX3DV4- SN:3847

April 26, 2018

DASY/EASY - Parameters of Probe: EX3DV4 - SN:3847

Basic Calibration Parameters

	Sensor X	Sensor Y	Sensor Z	Unc (k=2)
Norm ($\mu\text{V}/(\text{V}/\text{m})^2$) ^A	0.56	0.49	0.41	± 10.1 %
DCP (mV) ^B	96.4	98.7	97.4	

Modulation Calibration Parameters

UID	Communication System Name		A dB	B dB $\sqrt{\mu\text{V}}$	C	D dB	VR mV	Unc ^E (k=2)
0	CW	X	0.0	0.0	1.0	0.00	144.9	±3.0 %
		Y	0.0	0.0	1.0		138.9	
		Z	0.0	0.0	1.0		148.8	

Note: For details on UID parameters see Appendix.

Sensor Model Parameters

	C1 fF	C2 fF	α V ⁻¹	T1 ms.V ⁻²	T2 ms.V ⁻¹	T3 ms	T4 V ⁻²	T5 V ⁻¹	T6
X	44.20	340.6	37.46	10.93	0.386	5.086	0.074	0.571	1.009
Y	49.57	371.5	35.85	13.85	0.234	5.100	0.564	0.423	1.006
Z	36.62	278.7	36.64	6.046	0.415	5.038	0.000	0.401	1.009

The reported uncertainty of measurement is stated as the standard uncertainty of measurement multiplied by the coverage factor k=2, which for a normal distribution corresponds to a coverage probability of approximately 95%.

^A The uncertainties of Norm X,Y,Z do not affect the E²-field uncertainty inside TSL (see Pages 5 and 6).

^B Numerical linearization parameter: uncertainty not required.

^E Uncertainty is determined using the max. deviation from linear response applying rectangular distribution and is expressed for the square of the field value.



EX3DV4– SN:3847

April 26, 2018

DASY/EASY - Parameters of Probe: EX3DV4 - SN:3847

Calibration Parameter Determined in Head Tissue Simulating Media

f (MHz) ^C	Relative Permittivity ^F	Conductivity (S/m) ^F	ConvF X	ConvF Y	ConvF Z	Alpha ^G	Depth (mm) ^G	Unc (k=2)
450	43.5	0.87	10.49	10.49	10.49	0.14	1.20	± 13.3 %
750	41.9	0.89	9.82	9.82	9.82	0.60	0.80	± 12.0 %
835	41.5	0.90	9.61	9.61	9.61	0.50	0.80	± 12.0 %
900	41.5	0.97	9.42	9.42	9.42	0.42	0.93	± 12.0 %
1750	40.1	1.37	8.71	8.71	8.71	0.42	0.80	± 12.0 %
1900	40.0	1.40	8.30	8.30	8.30	0.27	0.80	± 12.0 %
2000	40.0	1.40	8.41	8.41	8.41	0.46	0.82	± 12.0 %
2300	39.5	1.67	7.79	7.79	7.79	0.38	0.84	± 12.0 %
2450	39.2	1.80	7.38	7.38	7.38	0.33	0.84	± 12.0 %
2600	39.0	1.96	7.18	7.18	7.18	0.43	0.80	± 12.0 %
5200	36.0	4.66	5.44	5.44	5.44	0.40	1.80	± 13.1 %
5300	35.9	4.76	5.22	5.22	5.22	0.40	1.80	± 13.1 %
5500	35.6	4.96	5.02	5.02	5.02	0.40	1.80	± 13.1 %
5600	35.5	5.07	4.80	4.80	4.80	0.40	1.80	± 13.1 %
5800	35.3	5.27	5.00	5.00	5.00	0.40	1.80	± 13.1 %

^C Frequency validity above 300 MHz of ± 100 MHz only applies for DASY v4.4 and higher (see Page 2), else it is restricted to ± 50 MHz. The uncertainty is the RSS of the ConvF uncertainty at calibration frequency and the uncertainty for the indicated frequency band. Frequency validity below 300 MHz is ± 10, 25, 40, 50 and 70 MHz for ConvF assessments at 30, 64, 128, 150 and 220 MHz respectively. Above 5 GHz frequency validity can be extended to ± 110 MHz.

^F At frequencies below 3 GHz, the validity of tissue parameters (ϵ and σ) can be relaxed to ± 10% if liquid compensation formula is applied to measured SAR values. At frequencies above 3 GHz, the validity of tissue parameters (ϵ and σ) is restricted to ± 5%. The uncertainty is the RSS of the ConvF uncertainty for indicated target tissue parameters.

^G Alpha/Depth are determined during calibration. SPEAG warrants that the remaining deviation due to the boundary effect after compensation is always less than ± 1% for frequencies below 3 GHz and below ± 2% for frequencies between 3-6 GHz at any distance larger than half the probe tip diameter from the boundary.



DASY/EASY - Parameters of Probe: EX3DV4 - SN:3847

Calibration Parameter Determined in Body Tissue Simulating Media

f (MHz) ^C	Relative Permittivity ^F	Conductivity (S/m) ^F	ConvF X	ConvF Y	ConvF Z	Alpha ^G	Depth (mm) ^D	Unc (k=2)
450	56.7	0.94	10.62	10.62	10.62	0.08	1.20	± 13.3 %
750	55.5	0.96	9.71	9.71	9.71	0.41	0.96	± 12.0 %
835	55.2	0.97	9.48	9.48	9.48	0.51	0.80	± 12.0 %
900	55.0	1.05	9.37	9.37	9.37	0.48	0.80	± 12.0 %
1750	53.4	1.49	7.91	7.91	7.91	0.34	0.94	± 12.0 %
1900	53.3	1.52	7.70	7.70	7.70	0.40	0.80	± 12.0 %
2000	53.3	1.52	7.76	7.76	7.76	0.37	0.84	± 12.0 %
2300	52.9	1.81	7.39	7.39	7.39	0.42	0.86	± 12.0 %
2450	52.7	1.95	7.30	7.30	7.30	0.32	0.87	± 12.0 %
2600	52.5	2.16	7.18	7.18	7.18	0.38	0.85	± 12.0 %
5200	49.0	5.30	4.84	4.84	4.84	0.50	1.90	± 13.1 %
5300	48.9	5.42	4.64	4.64	4.64	0.50	1.90	± 13.1 %
5500	48.6	5.65	4.28	4.28	4.28	0.50	1.90	± 13.1 %
5600	48.5	5.77	4.11	4.11	4.11	0.50	1.90	± 13.1 %
5800	48.2	6.00	4.29	4.29	4.29	0.50	1.90	± 13.1 %

^C Frequency validity above 300 MHz of ± 100 MHz only applies for DASY v4.4 and higher (see Page 2), else it is restricted to ± 50 MHz. The uncertainty is the RSS of the ConvF uncertainty at calibration frequency and the uncertainty for the indicated frequency band. Frequency validity below 300 MHz is ± 10, 25, 40, 50 and 70 MHz for ConvF assessments at 30, 64, 128, 150 and 220 MHz respectively. Above 5 GHz frequency validity can be extended to ± 110 MHz.

^F At frequencies below 3 GHz, the validity of tissue parameters (ϵ and σ) can be relaxed to ± 10% if liquid compensation formula is applied to measured SAR values. At frequencies above 3 GHz, the validity of tissue parameters (ϵ and σ) is restricted to ± 5%. The uncertainty is the RSS of the ConvF uncertainty for indicated target tissue parameters.

^G Alpha/Depth are determined during calibration. SPEAG warrants that the remaining deviation due to the boundary effect after compensation is always less than ± 1% for frequencies below 3 GHz and below ± 2% for frequencies between 3-6 GHz at any distance larger than half the probe tip diameter from the boundary.

Frequency Response of E-Field (TEM-Cell:ifi110 EXX, Waveguide: R22)

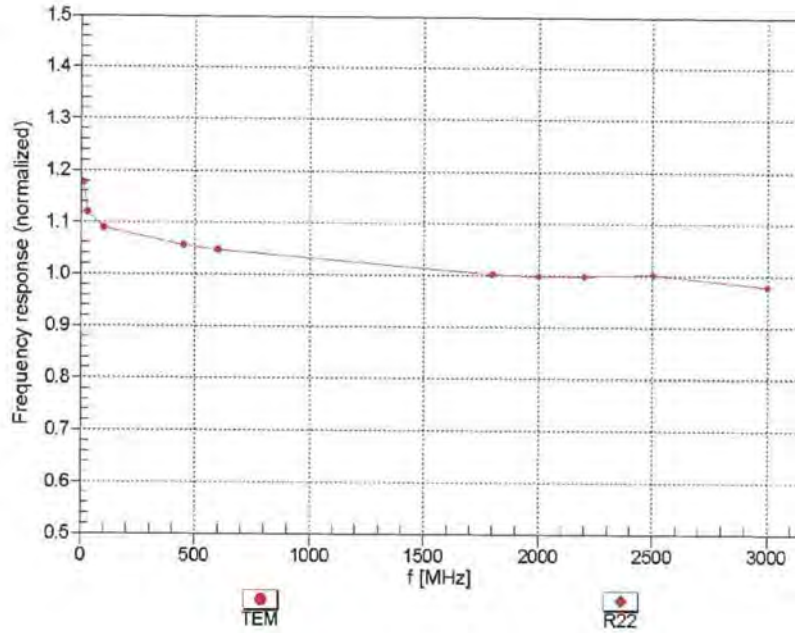

Uncertainty of Frequency Response of E-field: $\pm 6.3\%$ (k=2)

Receiving Pattern (ϕ), $\theta = 0^\circ$

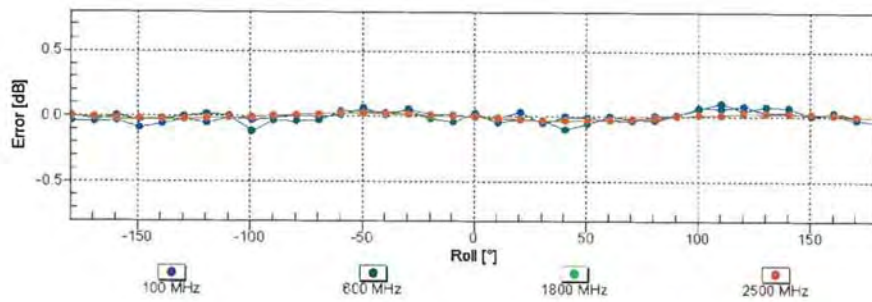
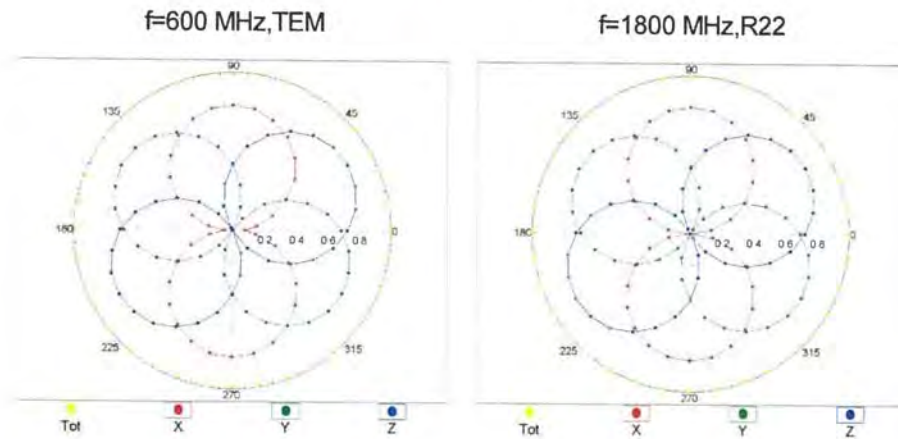

Uncertainty of Axial Isotropy Assessment: $\pm 0.5\%$ (k=2)

Dynamic Range $f(SAR_{head})$ (TEM cell , $f_{eval}= 1900$ MHz)

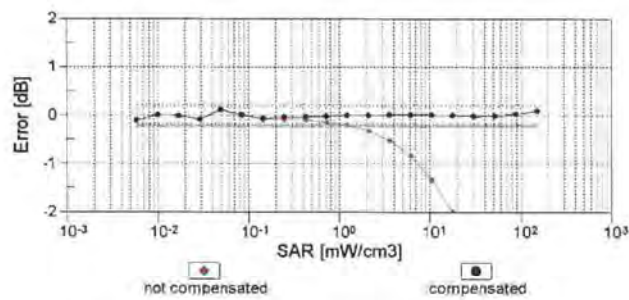
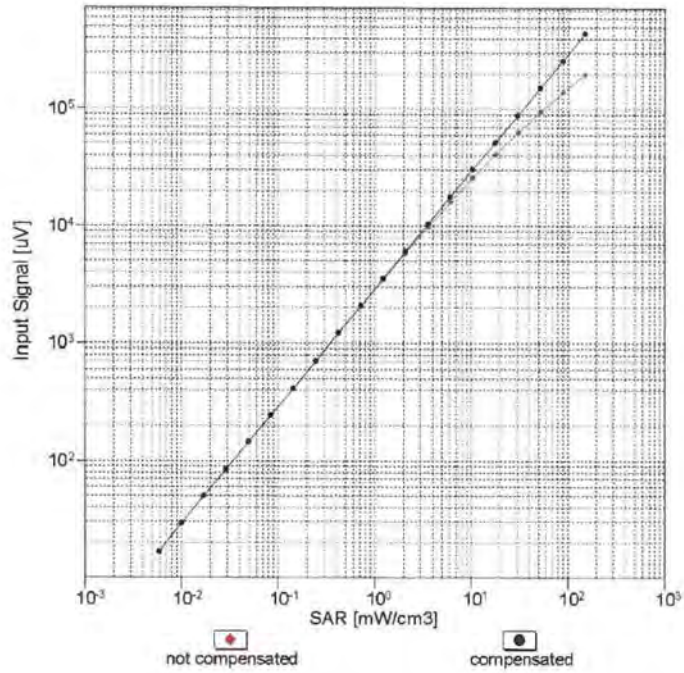

Uncertainty of Linearity Assessment: $\pm 0.6\%$ (k=2)

Conversion Factor Assessment

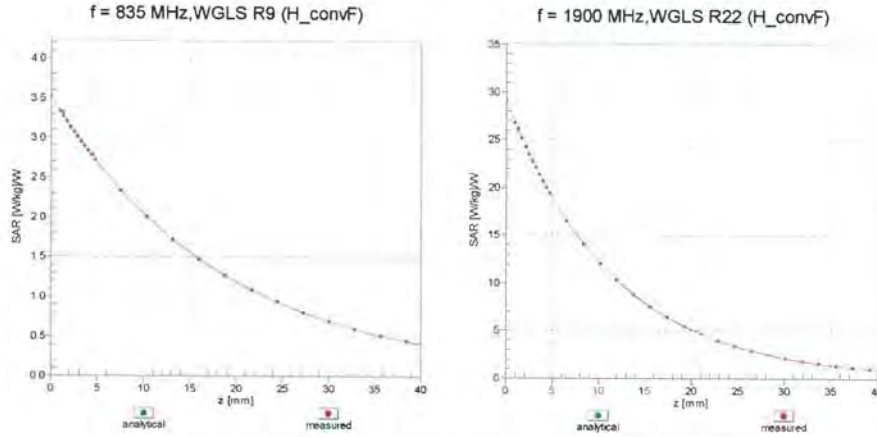

Deviation from Isotropy in Liquid

Error (ϕ, θ), $f = 900$ MHz

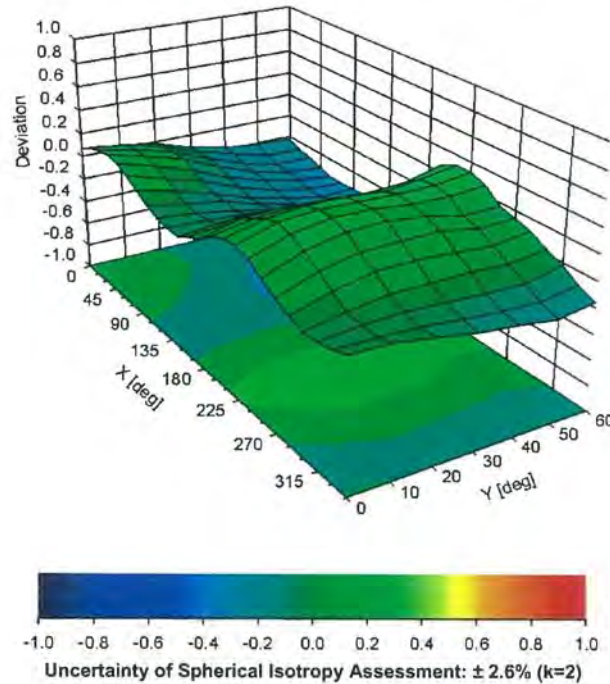



EX3DV4- SN:3847

April 26, 2018

DASY/EASY - Parameters of Probe: EX3DV4 - SN:3847

Other Probe Parameters

Sensor Arrangement	Triangular
Connector Angle (°)	100.5
Mechanical Surface Detection Mode	enabled
Optical Surface Detection Mode	disabled
Probe Overall Length	337 mm
Probe Body Diameter	10 mm
Tip Length	9 mm
Tip Diameter	2.5 mm
Probe Tip to Sensor X Calibration Point	1 mm
Probe Tip to Sensor Y Calibration Point	1 mm
Probe Tip to Sensor Z Calibration Point	1 mm
Recommended Measurement Distance from Surface	1.4 mm



EX3DV4- SN:3847

April 26, 2018

Appendix: Modulation Calibration Parameters

UID	Communication System Name		A dB	B dB-μV	C	D dB	VR mV	Max Unc ^E (k=2)
0	CW	X	0.00	0.00	1.00	0.00	144.9	± 3.0 %
		Y	0.00	0.00	1.00		138.9	
		Z	0.00	0.00	1.00		148.8	
10010- CAA	SAR Validation-(Square, 100ms, 10ms)	X	2.07	65.34	9.84	10.00	20.0	± 9.6 %
		Y	4.30	73.24	13.31		20.0	
		Z	1.71	62.89	8.19		20.0	
10011- CAB	UMTS-FDD (WCDMA)	X	0.83	64.13	12.78	0.00	150.0	± 9.6 %
		Y	1.01	67.17	15.08		150.0	
		Z	0.79	64.10	12.59		150.0	
10012- CAB	IEEE 802.11b WiFi 2.4 GHz (DSSS, 1 Mbps)	X	1.06	62.44	14.01	0.41	150.0	± 9.6 %
		Y	1.16	63.86	15.30		150.0	
		Z	1.02	62.22	13.74		150.0	
10013- CAB	IEEE 802.11g WiFi 2.4 GHz (DSSS-OFDM, 6 Mbps)	X	4.77	66.37	16.89	1.46	150.0	± 9.6 %
		Y	4.89	66.70	17.17		150.0	
		Z	4.60	66.32	16.67		150.0	
10021- DAC	GSM-FDD (TDMA, GMSK)	X	100.00	113.17	26.65	9.39	50.0	± 9.6 %
		Y	100.00	116.34	28.13		50.0	
		Z	100.00	107.45	23.86		50.0	
10023- DAC	GPRS-FDD (TDMA, GMSK, TN 0)	X	100.00	112.66	26.47	9.57	50.0	± 9.6 %
		Y	100.00	115.76	27.91		50.0	
		Z	22.94	91.16	19.83		50.0	
10024- DAC	GPRS-FDD (TDMA, GMSK, TN 0-1)	X	100.00	112.56	25.29	6.56	60.0	± 9.6 %
		Y	100.00	117.63	27.75		60.0	
		Z	100.00	105.44	21.74		60.0	
10025- DAC	EDGE-FDD (TDMA, 8PSK, TN 0)	X	4.03	70.07	26.46	12.57	50.0	± 9.6 %
		Y	5.97	83.97	34.33		50.0	
		Z	3.42	65.00	22.86		50.0	
10026- DAC	EDGE-FDD (TDMA, 8PSK, TN 0-1)	X	7.66	89.12	32.08	9.56	60.0	± 9.6 %
		Y	11.45	100.08	36.56		60.0	
		Z	5.68	81.84	28.68		60.0	
10027- DAC	GPRS-FDD (TDMA, GMSK, TN 0-1-2)	X	100.00	112.62	24.53	4.80	80.0	± 9.6 %
		Y	100.00	120.26	28.15		80.0	
		Z	100.00	104.13	20.37		80.0	
10028- DAC	GPRS-FDD (TDMA, GMSK, TN 0-1-2-3)	X	100.00	112.46	23.76	3.55	100.0	± 9.6 %
		Y	100.00	123.92	28.99		100.0	
		Z	100.00	102.29	18.93		100.0	
10029- DAC	EDGE-FDD (TDMA, 8PSK, TN 0-1-2)	X	4.96	78.87	26.64	7.80	80.0	± 9.6 %
		Y	6.39	85.09	29.52		80.0	
		Z	3.91	73.88	24.12		80.0	
10030- CAA	IEEE 802.15.1 Bluetooth (GFSK, DH1)	X	100.00	110.42	23.88	5.30	70.0	± 9.6 %
		Y	100.00	116.76	26.93		70.0	
		Z	100.00	102.53	19.97		70.0	
10031- CAA	IEEE 802.15.1 Bluetooth (GFSK, DH3)	X	100.00	100.57	17.59	1.88	100.0	± 9.6 %
		Y	100.00	123.52	27.31		100.0	
		Z	0.22	60.00	4.40		100.0	



EX3DV4- SN:3847

April 26, 2018

10032-CAA	IEEE 802.15.1 Bluetooth (GFSK, DH5)	X	0.93	68.53	8.07	1.17	100.0	± 9.6 %
		Y	100.00	130.89	29.13		100.0	
		Z	0.18	60.00	2.97		100.0	
10033-CAA	IEEE 802.15.1 Bluetooth (PI/4-DQPSK, DH1)	X	14.79	99.39	26.84	5.30	70.0	± 9.6 %
		Y	100.00	133.58	36.70		70.0	
		Z	4.18	78.83	18.83		70.0	
10034-CAA	IEEE 802.15.1 Bluetooth (PI/4-DQPSK, DH3)	X	2.15	72.78	15.94	1.88	100.0	± 9.6 %
		Y	6.14	88.93	22.90		100.0	
		Z	1.31	66.82	12.20		100.0	
10035-CAA	IEEE 802.15.1 Bluetooth (PI/4-DQPSK, DH5)	X	1.42	68.36	13.66	1.17	100.0	± 9.6 %
		Y	2.81	78.39	18.92		100.0	
		Z	1.01	64.84	10.92		100.0	
10036-CAA	IEEE 802.15.1 Bluetooth (8-DPSK, DH1)	X	25.55	108.22	29.36	5.30	70.0	± 9.6 %
		Y	100.00	134.11	36.94		70.0	
		Z	5.13	81.95	20.01		70.0	
10037-CAA	IEEE 802.15.1 Bluetooth (8-DPSK, DH3)	X	2.01	72.03	15.62	1.88	100.0	± 9.6 %
		Y	5.46	87.35	22.37		100.0	
		Z	1.24	66.30	11.95		100.0	
10038-CAA	IEEE 802.15.1 Bluetooth (8-DPSK, DH5)	X	1.43	68.60	13.88	1.17	100.0	± 9.6 %
		Y	2.85	78.92	19.24		100.0	
		Z	1.01	64.99	11.11		100.0	
10039-CAB	CDMA2000 (1xRTT, RC1)	X	1.11	65.51	11.66	0.00	150.0	± 9.6 %
		Y	1.79	71.64	15.54		150.0	
		Z	0.86	63.71	9.85		150.0	
10042-CAB	IS-54 / IS-136 FDD (TDMA/FDM, PI/4-DQPSK, Halfrate)	X	100.00	108.58	23.79	7.78	50.0	± 9.6 %
		Y	100.00	112.54	25.69		50.0	
		Z	5.07	75.45	13.78		50.0	
10044-CAA	IS-91/EIA/TIA-553 FDD (FDMA, FM)	X	0.04	118.81	12.58	0.00	150.0	± 9.6 %
		Y	0.00	106.69	7.66		150.0	
		Z	0.02	126.45	15.95		150.0	
10048-CAA	DECT (TDD, TDMA/FDM, GFSK, Full Slot, 24)	X	100.00	109.92	26.77	13.80	25.0	± 9.6 %
		Y	100.00	113.54	28.22		25.0	
		Z	6.55	73.12	15.37		25.0	
10049-CAA	DECT (TDD, TDMA/FDM, GFSK, Double Slot, 12)	X	100.00	111.23	26.17	10.79	40.0	± 9.6 %
		Y	100.00	113.76	27.29		40.0	
		Z	6.76	76.32	15.44		40.0	
10056-CAA	UMTS-TDD (TD-SCDMA, 1.28 Mcps)	X	70.38	118.63	32.01	9.03	50.0	± 9.6 %
		Y	100.00	127.71	35.17		50.0	
		Z	12.47	88.74	22.30		50.0	
10058-DAC	EDGE-FDD (TDMA, 8PSK, TN 0-1-2-3)	X	3.93	74.26	23.77	6.55	100.0	± 9.6 %
		Y	4.77	78.63	25.95		100.0	
		Z	3.22	70.50	21.79		100.0	
10059-CAB	IEEE 802.11b WiFi 2.4 GHz (DSSS, 2 Mbps)	X	1.08	63.31	14.55	0.61	110.0	± 9.6 %
		Y	1.20	65.14	16.07		110.0	
		Z	1.02	62.81	14.09		110.0	
10060-CAB	IEEE 802.11b WiFi 2.4 GHz (DSSS, 5.5 Mbps)	X	3.16	86.24	21.83	1.30	110.0	± 9.6 %
		Y	100.00	141.96	37.36		110.0	
		Z	1.42	75.84	17.84		110.0	



EX3DV4- SN:3847

April 26, 2018

10061-CAB	IEEE 802.11b WiFi 2.4 GHz (DSSS, 11 Mbps)	X	2.13	75.97	20.39	2.04	110.0	± 9.6 %
		Y	3.98	87.63	25.49		110.0	
		Z	1.48	70.69	17.76		110.0	
10062-CAC	IEEE 802.11a/h WiFi 5 GHz (OFDM, 6 Mbps)	X	4.55	66.28	16.23	0.49	100.0	± 9.6 %
		Y	4.69	66.66	16.54		100.0	
		Z	4.40	66.27	16.08		100.0	
10063-CAC	IEEE 802.11a/h WiFi 5 GHz (OFDM, 9 Mbps)	X	4.57	66.38	16.34	0.72	100.0	± 9.6 %
		Y	4.70	66.77	16.66		100.0	
		Z	4.41	66.35	16.17		100.0	
10064-CAC	IEEE 802.11a/h WiFi 5 GHz (OFDM, 12 Mbps)	X	4.85	66.66	16.59	0.86	100.0	± 9.6 %
		Y	5.00	67.05	16.90		100.0	
		Z	4.66	66.58	16.39		100.0	
10065-CAC	IEEE 802.11a/h WiFi 5 GHz (OFDM, 18 Mbps)	X	4.72	66.56	16.71	1.21	100.0	± 9.6 %
		Y	4.87	66.97	17.03		100.0	
		Z	4.53	66.42	16.46		100.0	
10066-CAC	IEEE 802.11a/h WiFi 5 GHz (OFDM, 24 Mbps)	X	4.74	66.59	16.88	1.46	100.0	± 9.6 %
		Y	4.89	67.00	17.21		100.0	
		Z	4.54	66.42	16.61		100.0	
10067-CAC	IEEE 802.11a/h WiFi 5 GHz (OFDM, 36 Mbps)	X	5.04	66.83	17.38	2.04	100.0	± 9.6 %
		Y	5.18	67.15	17.66		100.0	
		Z	4.83	66.70	17.10		100.0	
10068-CAC	IEEE 802.11a/h WiFi 5 GHz (OFDM, 48 Mbps)	X	5.08	66.86	17.61	2.55	100.0	± 9.6 %
		Y	5.23	67.25	17.93		100.0	
		Z	4.86	66.62	17.27		100.0	
10069-CAC	IEEE 802.11a/h WiFi 5 GHz (OFDM, 54 Mbps)	X	5.16	66.88	17.81	2.67	100.0	± 9.6 %
		Y	5.31	67.21	18.10		100.0	
		Z	4.93	66.66	17.47		100.0	
10071-CAB	IEEE 802.11g WiFi 2.4 GHz (DSSS/OFDM, 9 Mbps)	X	4.86	66.48	17.21	1.99	100.0	± 9.6 %
		Y	4.98	66.80	17.50		100.0	
		Z	4.70	66.39	16.97		100.0	
10072-CAB	IEEE 802.11g WiFi 2.4 GHz (DSSS/OFDM, 12 Mbps)	X	4.83	66.77	17.43	2.30	100.0	± 9.6 %
		Y	4.97	67.15	17.74		100.0	
		Z	4.64	66.60	17.13		100.0	
10073-CAB	IEEE 802.11g WiFi 2.4 GHz (DSSS/OFDM, 18 Mbps)	X	4.89	66.94	17.78	2.83	100.0	± 9.6 %
		Y	5.02	67.31	18.09		100.0	
		Z	4.70	66.75	17.45		100.0	
10074-CAB	IEEE 802.11g WiFi 2.4 GHz (DSSS/OFDM, 24 Mbps)	X	4.88	66.84	17.93	3.30	100.0	± 9.6 %
		Y	4.99	67.18	18.25		100.0	
		Z	4.70	66.67	17.60		100.0	
10075-CAB	IEEE 802.11g WiFi 2.4 GHz (DSSS/OFDM, 36 Mbps)	X	4.91	66.93	18.25	3.82	90.0	± 9.6 %
		Y	5.03	67.32	18.59		90.0	
		Z	4.71	66.68	17.85		90.0	
10076-CAB	IEEE 802.11g WiFi 2.4 GHz (DSSS/OFDM, 48 Mbps)	X	4.93	66.73	18.38	4.15	90.0	± 9.6 %
		Y	5.03	67.05	18.69		90.0	
		Z	4.75	66.56	18.02		90.0	
10077-CAB	IEEE 802.11g WiFi 2.4 GHz (DSSS/OFDM, 54 Mbps)	X	4.95	66.81	18.48	4.30	90.0	± 9.6 %
		Y	5.05	67.11	18.78		90.0	
		Z	4.78	66.64	18.13		90.0	

Certificate No: EX3-3847_Apr18

Page 14 of 39



EX3DV4- SN:3847

April 26, 2018

10081-CAB	CDMA2000 (1xRTT, RC3)	X	0.59	62.02	9.23	0.00	150.0	± 9.6 %
		Y	0.82	65.64	12.36		150.0	
		Z	0.47	60.88	7.65		150.0	
10082-CAB	IS-54 / IS-136 FDD (TDMA/FDM, PI/4-QPSK, Fullrate)	X	1.95	64.53	5.78	4.77	80.0	± 9.6 %
		Y	0.70	60.00	4.46		80.0	
		Z	0.60	60.00	3.26		80.0	
10090-DAC	GPRS-FDD (TDMA, GMSK, TN 0-4)	X	100.00	112.66	25.35	6.56	60.0	± 9.6 %
		Y	100.00	117.69	27.79		60.0	
		Z	100.00	105.52	21.80		60.0	
10097-CAB	UMTS-FDD (HSDPA)	X	1.60	65.59	14.08	0.00	150.0	± 9.6 %
		Y	1.81	67.49	15.56		150.0	
		Z	1.55	65.80	13.89		150.0	
10098-CAB	UMTS-FDD (HSUPA, Subtest 2)	X	1.57	65.52	14.03	0.00	150.0	± 9.6 %
		Y	1.77	67.44	15.53		150.0	
		Z	1.51	65.73	13.84		150.0	
10099-DAC	EDGE-FDD (TDMA, 8PSK, TN 0-4)	X	7.72	89.29	32.14	9.56	60.0	± 9.6 %
		Y	11.58	100.34	36.65		60.0	
		Z	5.71	81.96	28.73		60.0	
10100-CAD	LTE-FDD (SC-FDMA, 100% RB, 20 MHz, QPSK)	X	2.78	68.28	15.47	0.00	150.0	± 9.6 %
		Y	3.12	70.25	16.61		150.0	
		Z	2.67	68.17	15.43		150.0	
10101-CAD	LTE-FDD (SC-FDMA, 100% RB, 20 MHz, 16-QAM)	X	3.05	66.43	15.19	0.00	150.0	± 9.6 %
		Y	3.23	67.46	15.88		150.0	
		Z	2.94	66.36	15.10		150.0	
10102-CAD	LTE-FDD (SC-FDMA, 100% RB, 20 MHz, 64-QAM)	X	3.16	66.47	15.32	0.00	150.0	± 9.6 %
		Y	3.34	67.42	15.97		150.0	
		Z	3.05	66.43	15.25		150.0	
10103-CAD	LTE-TDD (SC-FDMA, 100% RB, 20 MHz, QPSK)	X	5.54	74.19	20.01	3.98	65.0	± 9.6 %
		Y	6.87	77.90	21.66		65.0	
		Z	4.95	72.89	19.25		65.0	
10104-CAD	LTE-TDD (SC-FDMA, 100% RB, 20 MHz, 16-QAM)	X	5.70	72.56	20.06	3.98	65.0	± 9.6 %
		Y	6.39	74.60	21.09		65.0	
		Z	4.99	70.72	19.00		65.0	
10105-CAD	LTE-TDD (SC-FDMA, 100% RB, 20 MHz, 64-QAM)	X	5.63	72.17	20.20	3.98	65.0	± 9.6 %
		Y	6.11	73.58	20.95		65.0	
		Z	4.89	70.10	19.03		65.0	
10108-CAE	LTE-FDD (SC-FDMA, 100% RB, 10 MHz, QPSK)	X	2.42	67.56	15.26	0.00	150.0	± 9.6 %
		Y	2.73	69.47	16.43		150.0	
		Z	2.30	67.47	15.19		150.0	
10109-CAE	LTE-FDD (SC-FDMA, 100% RB, 10 MHz, 16-QAM)	X	2.69	66.17	14.97	0.00	150.0	± 9.6 %
		Y	2.89	67.29	15.77		150.0	
		Z	2.57	66.14	14.84		150.0	
10110-CAE	LTE-FDD (SC-FDMA, 100% RB, 5 MHz, QPSK)	X	1.93	66.56	14.88	0.00	150.0	± 9.6 %
		Y	2.21	68.55	16.04		150.0	
		Z	1.81	66.45	14.48		150.0	
10111-CAE	LTE-FDD (SC-FDMA, 100% RB, 5 MHz, 16-QAM)	X	2.36	66.62	14.95	0.00	150.0	± 9.6 %
		Y	2.60	68.05	16.04		150.0	
		Z	2.25	66.73	14.74		150.0	



EX3DV4- SN:3847

April 26, 2018

10112-CAE	LTE-FDD (SC-FDMA, 100% RB, 10 MHz, 64-QAM)	X	2.82	66.25	15.08	0.00	150.0	± 9.6 %
		Y	3.02	67.28	15.83		150.0	
		Z	2.70	66.26	14.96		150.0	
10113-CAE	LTE-FDD (SC-FDMA, 100% RB, 5 MHz, 64-QAM)	X	2.51	66.86	15.14	0.00	150.0	± 9.6 %
		Y	2.76	68.19	16.18		150.0	
		Z	2.39	67.00	14.94		150.0	
10114-CAC	IEEE 802.11n (HT Greenfield, 13.5 Mbps, BPSK)	X	5.01	66.79	16.16	0.00	150.0	± 9.6 %
		Y	5.12	67.14	16.40		150.0	
		Z	4.87	66.71	16.08		150.0	
10115-CAC	IEEE 802.11n (HT Greenfield, 81 Mbps, 16-QAM)	X	5.28	66.89	16.23	0.00	150.0	± 9.6 %
		Y	5.42	67.30	16.49		150.0	
		Z	5.12	66.82	16.14		150.0	
10116-CAC	IEEE 802.11n (HT Greenfield, 135 Mbps, 64-QAM)	X	5.10	66.95	16.17	0.00	150.0	± 9.6 %
		Y	5.22	67.34	16.43		150.0	
		Z	4.95	66.90	16.10		150.0	
10117-CAC	IEEE 802.11n (HT Mixed, 13.5 Mbps, BPSK)	X	4.97	66.63	16.10	0.00	150.0	± 9.6 %
		Y	5.09	67.02	16.35		150.0	
		Z	4.86	66.67	16.07		150.0	
10118-CAC	IEEE 802.11n (HT Mixed, 81 Mbps, 16-QAM)	X	5.36	67.10	16.34	0.00	150.0	± 9.6 %
		Y	5.50	67.51	16.60		150.0	
		Z	5.20	67.01	16.25		150.0	
10119-CAC	IEEE 802.11n (HT Mixed, 135 Mbps, 64-QAM)	X	5.08	66.93	16.17	0.00	150.0	± 9.6 %
		Y	5.20	67.28	16.41		150.0	
		Z	4.95	66.90	16.11		150.0	
10140-CAD	LTE-FDD (SC-FDMA, 100% RB, 15 MHz, 16-QAM)	X	3.19	66.48	15.24	0.00	150.0	± 9.6 %
		Y	3.38	67.43	15.89		150.0	
		Z	3.07	66.44	15.16		150.0	
10141-CAD	LTE-FDD (SC-FDMA, 100% RB, 15 MHz, 64-QAM)	X	3.31	66.63	15.45	0.00	150.0	± 9.6 %
		Y	3.50	67.52	16.06		150.0	
		Z	3.20	66.63	15.38		150.0	
10142-CAD	LTE-FDD (SC-FDMA, 100% RB, 3 MHz, QPSK)	X	1.68	66.15	14.00	0.00	150.0	± 9.6 %
		Y	1.98	68.50	15.70		150.0	
		Z	1.53	65.91	13.53		150.0	
10143-CAD	LTE-FDD (SC-FDMA, 100% RB, 3 MHz, 16-QAM)	X	2.12	66.68	14.17	0.00	150.0	± 9.6 %
		Y	2.46	68.76	15.76		150.0	
		Z	1.96	66.44	13.54		150.0	
10144-CAD	LTE-FDD (SC-FDMA, 100% RB, 3 MHz, 64-QAM)	X	1.97	64.86	12.76	0.00	150.0	± 9.6 %
		Y	2.24	66.53	14.19		150.0	
		Z	1.77	64.38	11.96		150.0	
10145-CAE	LTE-FDD (SC-FDMA, 100% RB, 1.4 MHz, QPSK)	X	0.91	61.85	9.05	0.00	150.0	± 9.6 %
		Y	1.23	65.13	11.88		150.0	
		Z	0.69	60.25	7.05		150.0	
10146-CAE	LTE-FDD (SC-FDMA, 100% RB, 1.4 MHz, 16-QAM)	X	1.50	63.32	9.63	0.00	150.0	± 9.6 %
		Y	1.90	65.91	11.56		150.0	
		Z	1.01	60.65	7.03		150.0	
10147-CAE	LTE-FDD (SC-FDMA, 100% RB, 1.4 MHz, 64-QAM)	X	1.63	64.25	10.24	0.00	150.0	± 9.6 %
		Y	2.20	67.75	12.58		150.0	
		Z	1.06	61.03	7.34		150.0	

Certificate No: EX3-3847_Apr18

Page 16 of 39



EX3DV4- SN:3847

April 26, 2018

10149-CAD	LTE-FDD (SC-FDMA, 50% RB, 20 MHz, 16-QAM)	X	2.70	66.23	15.02	0.00	150.0	± 9.6 %
		Y	2.90	67.35	15.82		150.0	
		Z	2.58	66.20	14.89		150.0	
10150-CAD	LTE-FDD (SC-FDMA, 50% RB, 20 MHz, 64-QAM)	X	2.83	66.30	15.12	0.00	150.0	± 9.6 %
		Y	3.02	67.33	15.87		150.0	
		Z	2.71	66.32	15.01		150.0	
10151-CAD	LTE-TDD (SC-FDMA, 50% RB, 20 MHz, QPSK)	X	5.97	77.23	21.34	3.98	65.0	± 9.6 %
		Y	7.34	80.80	22.94		65.0	
		Z	4.90	74.53	19.96		65.0	
10152-CAD	LTE-TDD (SC-FDMA, 50% RB, 20 MHz, 16-QAM)	X	5.22	72.48	19.71	3.98	65.0	± 9.6 %
		Y	5.95	74.75	20.92		65.0	
		Z	4.50	70.46	18.46		65.0	
10153-CAD	LTE-TDD (SC-FDMA, 50% RB, 20 MHz, 64-QAM)	X	5.58	73.49	20.53	3.98	65.0	± 9.6 %
		Y	6.32	75.66	21.67		65.0	
		Z	4.84	71.57	19.35		65.0	
10154-CAE	LTE-FDD (SC-FDMA, 50% RB, 10 MHz, QPSK)	X	1.96	66.86	14.89	0.00	150.0	± 9.6 %
		Y	2.26	68.96	16.30		150.0	
		Z	1.84	66.75	14.68		150.0	
10155-CAE	LTE-FDD (SC-FDMA, 50% RB, 10 MHz, 16-QAM)	X	2.36	66.64	14.97	0.00	150.0	± 9.6 %
		Y	2.60	68.06	16.06		150.0	
		Z	2.25	66.77	14.76		150.0	
10156-CAE	LTE-FDD (SC-FDMA, 50% RB, 5 MHz, QPSK)	X	1.50	65.80	13.47	0.00	150.0	± 9.6 %
		Y	1.83	68.59	15.50		150.0	
		Z	1.34	65.32	12.76		150.0	
10157-CAE	LTE-FDD (SC-FDMA, 50% RB, 5 MHz, 16-QAM)	X	1.75	64.90	12.44	0.00	150.0	± 9.6 %
		Y	2.08	67.08	14.22		150.0	
		Z	1.54	64.16	11.40		150.0	
10158-CAE	LTE-FDD (SC-FDMA, 50% RB, 10 MHz, 64-QAM)	X	2.51	66.91	15.19	0.00	150.0	± 9.6 %
		Y	2.76	68.25	16.22		150.0	
		Z	2.40	67.07	14.99		150.0	
10159-CAE	LTE-FDD (SC-FDMA, 50% RB, 5 MHz, 64-QAM)	X	1.83	65.22	12.66	0.00	150.0	± 9.6 %
		Y	2.19	67.55	14.51		150.0	
		Z	1.60	64.40	11.57		150.0	
10160-CAD	LTE-FDD (SC-FDMA, 50% RB, 15 MHz, QPSK)	X	2.50	67.15	15.27	0.00	150.0	± 9.6 %
		Y	2.73	68.52	16.21		150.0	
		Z	2.38	67.14	15.17		150.0	
10161-CAD	LTE-FDD (SC-FDMA, 50% RB, 15 MHz, 16-QAM)	X	2.72	66.21	15.00	0.00	150.0	± 9.6 %
		Y	2.92	67.27	15.80		150.0	
		Z	2.60	66.22	14.84		150.0	
10162-CAD	LTE-FDD (SC-FDMA, 50% RB, 15 MHz, 64-QAM)	X	2.83	66.40	15.14	0.00	150.0	± 9.6 %
		Y	3.03	67.41	15.91		150.0	
		Z	2.70	66.46	15.00		150.0	
10166-CAE	LTE-FDD (SC-FDMA, 50% RB, 1.4 MHz, QPSK)	X	3.42	68.83	18.71	3.01	150.0	± 9.6 %
		Y	3.54	69.27	18.90		150.0	
		Z	3.10	68.24	18.48		150.0	
10167-CAE	LTE-FDD (SC-FDMA, 50% RB, 1.4 MHz, 16-QAM)	X	4.10	71.30	18.97	3.01	150.0	± 9.6 %
		Y	4.35	72.13	19.35		150.0	
		Z	3.54	70.41	18.64		150.0	



EX3DV4- SN:3847

April 26, 2018

10168-CAE	LTE-FDD (SC-FDMA, 50% RB, 1.4 MHz, 64-QAM)	X	4.56	73.60	20.36	3.01	150.0	± 9.6 %
		Y	4.82	74.35	20.66		150.0	
		Z	3.99	73.05	20.25		150.0	
10169-CAD	LTE-FDD (SC-FDMA, 1 RB, 20 MHz, QPSK)	X	2.83	67.78	18.21	3.01	150.0	± 9.6 %
		Y	2.94	68.87	18.74		150.0	
		Z	2.47	66.42	17.63		150.0	
10170-CAD	LTE-FDD (SC-FDMA, 1 RB, 20 MHz, 16-QAM)	X	3.69	72.71	20.18	3.01	150.0	± 9.6 %
		Y	4.05	74.82	21.07		150.0	
		Z	3.02	70.89	19.59		150.0	
10171-AAD	LTE-FDD (SC-FDMA, 1 RB, 20 MHz, 64-QAM)	X	3.09	69.04	17.57	3.01	150.0	± 9.6 %
		Y	3.32	70.68	18.31		150.0	
		Z	2.54	67.28	16.84		150.0	
10172-CAD	LTE-TDD (SC-FDMA, 1 RB, 20 MHz, QPSK)	X	5.32	83.38	26.21	6.02	65.0	± 9.6 %
		Y	11.00	98.30	31.47		65.0	
		Z	3.71	77.97	23.91		65.0	
10173-CAD	LTE-TDD (SC-FDMA, 1 RB, 20 MHz, 16-QAM)	X	11.57	94.78	28.24	6.02	65.0	± 9.6 %
		Y	30.00	112.19	33.34		65.0	
		Z	5.47	83.37	24.17		65.0	
10174-CAD	LTE-TDD (SC-FDMA, 1 RB, 20 MHz, 64-QAM)	X	10.34	91.58	26.62	6.02	65.0	± 9.6 %
		Y	20.61	103.66	30.29		65.0	
		Z	3.98	77.30	21.37		65.0	
10175-CAE	LTE-FDD (SC-FDMA, 1 RB, 10 MHz, QPSK)	X	2.80	67.51	17.97	3.01	150.0	± 9.6 %
		Y	2.91	68.57	18.50		150.0	
		Z	2.45	66.15	17.39		150.0	
10176-CAE	LTE-FDD (SC-FDMA, 1 RB, 10 MHz, 16-QAM)	X	3.70	72.73	20.19	3.01	150.0	± 9.6 %
		Y	4.06	74.85	21.08		150.0	
		Z	3.03	70.91	19.61		150.0	
10177-CAG	LTE-FDD (SC-FDMA, 1 RB, 5 MHz, QPSK)	X	2.82	67.64	18.06	3.01	150.0	± 9.6 %
		Y	2.93	68.72	18.59		150.0	
		Z	2.46	66.27	17.47		150.0	
10178-CAE	LTE-FDD (SC-FDMA, 1 RB, 5 MHz, 16-QAM)	X	3.67	72.56	20.09	3.01	150.0	± 9.6 %
		Y	4.01	74.62	20.96		150.0	
		Z	3.01	70.76	19.51		150.0	
10179-CAE	LTE-FDD (SC-FDMA, 1 RB, 10 MHz, 64-QAM)	X	3.36	70.75	18.74	3.01	150.0	± 9.6 %
		Y	3.65	72.62	19.55		150.0	
		Z	2.75	68.95	18.07		150.0	
10180-CAE	LTE-FDD (SC-FDMA, 1 RB, 5 MHz, 64-QAM)	X	3.09	68.99	17.53	3.01	150.0	± 9.6 %
		Y	3.31	70.61	18.26		150.0	
		Z	2.53	67.24	16.81		150.0	
10181-CAD	LTE-FDD (SC-FDMA, 1 RB, 15 MHz, QPSK)	X	2.81	67.62	18.05	3.01	150.0	± 9.6 %
		Y	2.93	68.70	18.58		150.0	
		Z	2.46	66.26	17.47		150.0	
10182-CAD	LTE-FDD (SC-FDMA, 1 RB, 15 MHz, 16-QAM)	X	3.66	72.54	20.08	3.01	150.0	± 9.6 %
		Y	4.01	74.60	20.95		150.0	
		Z	3.00	70.74	19.50		150.0	
10183-AAC	LTE-FDD (SC-FDMA, 1 RB, 15 MHz, 64-QAM)	X	3.08	68.97	17.52	3.01	150.0	± 9.6 %
		Y	3.30	70.59	18.25		150.0	
		Z	2.53	67.23	16.80		150.0	

Certificate No: EX3-3847_Apr18

Page 18 of 39



EX3DV4- SN:3847

April 26, 2018

10184-CAD	LTE-FDD (SC-FDMA, 1 RB, 3 MHz, QPSK)	X	2.82	67.66	18.07	3.01	150.0	± 9.6 %
		Y	2.94	68.74	18.61		150.0	
		Z	2.47	66.29	17.49		150.0	
10185-CAD	LTE-FDD (SC-FDMA, 1 RB, 3 MHz, 16-QAM)	X	3.68	72.60	20.12	3.01	150.0	± 9.6 %
		Y	4.03	74.67	20.99		150.0	
		Z	3.02	70.81	19.54		150.0	
10186-AAD	LTE-FDD (SC-FDMA, 1 RB, 3 MHz, 64-QAM)	X	3.10	69.03	17.55	3.01	150.0	± 9.6 %
		Y	3.32	70.66	18.28		150.0	
		Z	2.54	67.28	16.83		150.0	
10187-CAE	LTE-FDD (SC-FDMA, 1 RB, 1.4 MHz, QPSK)	X	2.83	67.72	18.14	3.01	150.0	± 9.6 %
		Y	2.95	68.79	18.67		150.0	
		Z	2.48	66.36	17.57		150.0	
10188-CAE	LTE-FDD (SC-FDMA, 1 RB, 1.4 MHz, 16-QAM)	X	3.78	73.17	20.46	3.01	150.0	± 9.6 %
		Y	4.16	75.34	21.37		150.0	
		Z	3.10	71.36	19.90		150.0	
10189-AAE	LTE-FDD (SC-FDMA, 1 RB, 1.4 MHz, 64-QAM)	X	3.15	69.39	17.80	3.01	150.0	± 9.6 %
		Y	3.39	71.08	18.56		150.0	
		Z	2.59	67.61	17.09		150.0	
10193-CAC	IEEE 802.11n (HT Greenfield, 6.5 Mbps, BPSK)	X	4.39	66.15	15.78	0.00	150.0	± 9.6 %
		Y	4.52	66.55	16.11		150.0	
		Z	4.27	66.26	15.71		150.0	
10194-CAC	IEEE 802.11n (HT Greenfield, 39 Mbps, 16-QAM)	X	4.55	66.45	15.91	0.00	150.0	± 9.6 %
		Y	4.69	66.87	16.23		150.0	
		Z	4.41	66.51	15.85		150.0	
10195-CAC	IEEE 802.11n (HT Greenfield, 65 Mbps, 64-QAM)	X	4.59	66.48	15.94	0.00	150.0	± 9.6 %
		Y	4.74	66.90	16.25		150.0	
		Z	4.44	66.54	15.87		150.0	
10196-CAC	IEEE 802.11n (HT Mixed, 6.5 Mbps, BPSK)	X	4.39	66.19	15.79	0.00	150.0	± 9.6 %
		Y	4.52	66.61	16.13		150.0	
		Z	4.25	66.27	15.70		150.0	
10197-CAC	IEEE 802.11n (HT Mixed, 39 Mbps, 16-QAM)	X	4.56	66.47	15.93	0.00	150.0	± 9.6 %
		Y	4.71	66.89	16.24		150.0	
		Z	4.42	66.52	15.86		150.0	
10198-CAC	IEEE 802.11n (HT Mixed, 65 Mbps, 64-QAM)	X	4.59	66.50	15.95	0.00	150.0	± 9.6 %
		Y	4.74	66.92	16.26		150.0	
		Z	4.44	66.54	15.88		150.0	
10219-CAC	IEEE 802.11n (HT Mixed, 7.2 Mbps, BPSK)	X	4.33	66.20	15.74	0.00	150.0	± 9.6 %
		Y	4.47	66.63	16.09		150.0	
		Z	4.20	66.29	15.66		150.0	
10220-CAC	IEEE 802.11n (HT Mixed, 43.3 Mbps, 16-QAM)	X	4.55	66.43	15.92	0.00	150.0	± 9.6 %
		Y	4.70	66.86	16.23		150.0	
		Z	4.41	66.48	15.85		150.0	
10221-CAC	IEEE 802.11n (HT Mixed, 72.2 Mbps, 64-QAM)	X	4.60	66.44	15.94	0.00	150.0	± 9.6 %
		Y	4.75	66.84	16.24		150.0	
		Z	4.45	66.49	15.87		150.0	
10222-CAC	IEEE 802.11n (HT Mixed, 15 Mbps, BPSK)	X	4.95	66.63	16.09	0.00	150.0	± 9.6 %
		Y	5.07	67.03	16.35		150.0	
		Z	4.83	66.64	16.05		150.0	



EX3DV4- SN:3847

April 26, 2018

10223-CAC	IEEE 802.11n (HT Mixed, 90 Mbps, 16-QAM)	X	5.26	66.93	16.27	0.00	150.0	± 9.6 %
		Y	5.37	67.22	16.47		150.0	
		Z	5.11	66.88	16.19		150.0	
10224-CAC	IEEE 802.11n (HT Mixed, 150 Mbps, 64-QAM)	X	4.99	66.73	16.07	0.00	150.0	± 9.6 %
		Y	5.11	67.14	16.33		150.0	
		Z	4.87	66.74	16.03		150.0	
10225-CAB	UMTS-FDD (HSPA+)	X	2.62	65.18	14.48	0.00	150.0	± 9.6 %
		Y	2.79	66.03	15.28		150.0	
		Z	2.49	65.19	14.14		150.0	
10226-CAA	LTE-TDD (SC-FDMA, 1 RB, 1.4 MHz, 16-QAM)	X	12.41	96.19	28.79	6.02	65.0	± 9.6 %
		Y	33.69	114.53	34.08		65.0	
		Z	5.79	84.47	24.66		65.0	
10227-CAA	LTE-TDD (SC-FDMA, 1 RB, 1.4 MHz, 64-QAM)	X	12.38	94.72	27.67	6.02	65.0	± 9.6 %
		Y	30.02	110.23	32.17		65.0	
		Z	5.87	83.75	23.75		65.0	
10228-CAA	LTE-TDD (SC-FDMA, 1 RB, 1.4 MHz, QPSK)	X	7.23	90.02	28.71	6.02	65.0	± 9.6 %
		Y	13.03	102.13	32.77		65.0	
		Z	4.00	79.75	24.71		65.0	
10229-CAB	LTE-TDD (SC-FDMA, 1 RB, 3 MHz, 16-QAM)	X	11.66	94.88	28.28	6.02	65.0	± 9.6 %
		Y	30.27	112.32	33.39		65.0	
		Z	5.51	83.47	24.21		65.0	
10230-CAB	LTE-TDD (SC-FDMA, 1 RB, 3 MHz, 64-QAM)	X	11.55	93.41	27.18	6.02	65.0	± 9.6 %
		Y	27.02	108.22	31.54		65.0	
		Z	5.53	82.68	23.29		65.0	
10231-CAB	LTE-TDD (SC-FDMA, 1 RB, 3 MHz, QPSK)	X	6.92	89.07	28.29	6.02	65.0	± 9.6 %
		Y	12.27	100.80	32.26		65.0	
		Z	3.87	79.05	24.34		65.0	
10232-CAD	LTE-TDD (SC-FDMA, 1 RB, 5 MHz, 16-QAM)	X	11.64	94.87	28.28	6.02	65.0	± 9.6 %
		Y	30.23	112.32	33.38		65.0	
		Z	5.50	83.45	24.20		65.0	
10233-CAD	LTE-TDD (SC-FDMA, 1 RB, 5 MHz, 64-QAM)	X	11.51	93.37	27.17	6.02	65.0	± 9.6 %
		Y	26.94	108.19	31.53		65.0	
		Z	5.52	82.64	23.28		65.0	
10234-CAD	LTE-TDD (SC-FDMA, 1 RB, 5 MHz, QPSK)	X	6.69	88.26	27.89	6.02	65.0	± 9.6 %
		Y	11.68	99.60	31.76		65.0	
		Z	3.77	78.47	23.99		65.0	
10235-CAD	LTE-TDD (SC-FDMA, 1 RB, 10 MHz, 16-QAM)	X	11.65	94.90	28.29	6.02	65.0	± 9.6 %
		Y	30.32	112.40	33.41		65.0	
		Z	5.50	83.47	24.21		65.0	
10236-CAD	LTE-TDD (SC-FDMA, 1 RB, 10 MHz, 64-QAM)	X	11.66	93.56	27.23	6.02	65.0	± 9.6 %
		Y	27.49	108.50	31.61		65.0	
		Z	5.57	82.78	23.32		65.0	
10237-CAD	LTE-TDD (SC-FDMA, 1 RB, 10 MHz, QPSK)	X	6.93	89.12	28.32	6.02	65.0	± 9.6 %
		Y	12.32	100.92	32.31		65.0	
		Z	3.86	79.06	24.35		65.0	
10238-CAD	LTE-TDD (SC-FDMA, 1 RB, 15 MHz, 16-QAM)	X	11.61	94.84	28.27	6.02	65.0	± 9.6 %
		Y	30.17	112.30	33.38		65.0	
		Z	5.49	83.42	24.19		65.0	

Certificate No: EX3-3847_Apr18

Page 20 of 39



EX3DV4- SN:3847

April 26, 2018

10239-CAD	LTE-TDD (SC-FDMA, 1 RB, 15 MHz, 64-QAM)	X	11.47	93.33	27.16	6.02	65.0	± 9.6 %
		Y	26.85	108.15	31.52		65.0	
		Z	5.50	82.60	23.27		65.0	
10240-CAD	LTE-TDD (SC-FDMA, 1 RB, 15 MHz, QPSK)	X	6.91	89.08	28.30	6.02	65.0	± 9.6 %
		Y	12.27	100.85	32.29		65.0	
		Z	3.86	79.03	24.34		65.0	
10241-CAA	LTE-TDD (SC-FDMA, 50% RB, 1.4 MHz, 16-QAM)	X	7.44	80.10	25.19	6.98	65.0	± 9.6 %
		Y	8.19	81.97	26.06		65.0	
		Z	6.09	77.56	23.93		65.0	
10242-CAA	LTE-TDD (SC-FDMA, 50% RB, 1.4 MHz, 64-QAM)	X	7.23	79.51	24.87	6.98	65.0	± 9.6 %
		Y	7.66	80.54	25.40		65.0	
		Z	5.78	76.55	23.42		65.0	
10243-CAA	LTE-TDD (SC-FDMA, 50% RB, 1.4 MHz, QPSK)	X	5.33	73.92	23.32	6.98	65.0	± 9.6 %
		Y	6.09	76.75	24.72		65.0	
		Z	4.88	73.49	22.94		65.0	
10244-CAB	LTE-TDD (SC-FDMA, 50% RB, 3 MHz, 16-QAM)	X	5.26	74.70	17.95	3.98	65.0	± 9.6 %
		Y	6.85	78.90	20.11		65.0	
		Z	3.39	68.77	14.26		65.0	
10245-CAB	LTE-TDD (SC-FDMA, 50% RB, 3 MHz, 64-QAM)	X	5.09	73.91	17.56	3.98	65.0	± 9.6 %
		Y	6.59	78.01	19.70		65.0	
		Z	3.32	68.22	13.93		65.0	
10246-CAB	LTE-TDD (SC-FDMA, 50% RB, 3 MHz, QPSK)	X	4.63	76.49	18.84	3.98	65.0	± 9.6 %
		Y	8.01	85.54	22.95		65.0	
		Z	2.86	69.76	14.97		65.0	
10247-CAD	LTE-TDD (SC-FDMA, 50% RB, 5 MHz, 16-QAM)	X	4.37	72.37	17.80	3.98	65.0	± 9.6 %
		Y	5.53	76.31	20.08		65.0	
		Z	3.35	68.75	15.27		65.0	
10248-CAD	LTE-TDD (SC-FDMA, 50% RB, 5 MHz, 64-QAM)	X	4.35	71.77	17.51	3.98	65.0	± 9.6 %
		Y	5.45	75.47	19.69		65.0	
		Z	3.35	68.30	15.04		65.0	
10249-CAD	LTE-TDD (SC-FDMA, 50% RB, 5 MHz, QPSK)	X	5.84	80.40	21.44	3.98	65.0	± 9.6 %
		Y	9.16	88.22	24.82		65.0	
		Z	3.94	74.55	18.36		65.0	
10250-CAD	LTE-TDD (SC-FDMA, 50% RB, 10 MHz, 16-QAM)	X	5.24	74.90	20.72	3.98	65.0	± 9.6 %
		Y	6.18	77.83	22.27		65.0	
		Z	4.37	72.40	19.13		65.0	
10251-CAD	LTE-TDD (SC-FDMA, 50% RB, 10 MHz, 64-QAM)	X	5.01	72.81	19.41	3.98	65.0	± 9.6 %
		Y	5.83	75.38	20.86		65.0	
		Z	4.19	70.42	17.81		65.0	
10252-CAD	LTE-TDD (SC-FDMA, 50% RB, 10 MHz, QPSK)	X	6.05	79.98	22.38	3.98	65.0	± 9.6 %
		Y	8.11	85.15	24.64		65.0	
		Z	4.65	76.16	20.44		65.0	
10253-CAD	LTE-TDD (SC-FDMA, 50% RB, 15 MHz, 16-QAM)	X	5.13	72.01	19.46	3.98	65.0	± 9.6 %
		Y	5.79	74.09	20.63		65.0	
		Z	4.45	70.14	18.22		65.0	
10254-CAD	LTE-TDD (SC-FDMA, 50% RB, 15 MHz, 64-QAM)	X	5.46	72.93	20.18	3.98	65.0	± 9.6 %
		Y	6.14	74.96	21.31		65.0	
		Z	4.75	71.10	18.98		65.0	



EX3DV4- SN:3847

April 26, 2018

10255-CAD	LTE-TDD (SC-FDMA, 50% RB, 15 MHz, QPSK)	X	5.67	76.47	21.24	3.98	65.0	± 9.6 %
		Y	6.83	79.72	22.76		65.0	
		Z	4.70	73.94	19.86		65.0	
10256-CAA	LTE-TDD (SC-FDMA, 100% RB, 1.4 MHz, 16-QAM)	X	3.85	69.91	14.71	3.98	65.0	± 9.6 %
		Y	5.28	74.58	17.30		65.0	
		Z	2.42	64.50	10.86		65.0	
10257-CAA	LTE-TDD (SC-FDMA, 100% RB, 1.4 MHz, 64-QAM)	X	3.71	69.05	14.20	3.98	65.0	± 9.6 %
		Y	5.01	73.44	16.72		65.0	
		Z	2.38	64.04	10.51		65.0	
10258-CAA	LTE-TDD (SC-FDMA, 100% RB, 1.4 MHz, QPSK)	X	3.27	70.95	15.52	3.98	65.0	± 9.6 %
		Y	5.77	79.71	19.94		65.0	
		Z	2.03	65.05	11.54		65.0	
10259-CAB	LTE-TDD (SC-FDMA, 100% RB, 3 MHz, 16-QAM)	X	4.73	73.41	18.90	3.98	65.0	± 9.6 %
		Y	5.80	76.88	20.87		65.0	
		Z	3.76	70.25	16.74		65.0	
10260-CAB	LTE-TDD (SC-FDMA, 100% RB, 3 MHz, 64-QAM)	X	4.75	73.12	18.77	3.98	65.0	± 9.6 %
		Y	5.79	76.46	20.69		65.0	
		Z	3.80	70.04	16.63		65.0	
10261-CAB	LTE-TDD (SC-FDMA, 100% RB, 3 MHz, QPSK)	X	5.60	79.27	21.48	3.98	65.0	± 9.6 %
		Y	7.94	85.39	24.24		65.0	
		Z	4.08	74.65	18.96		65.0	
10262-CAD	LTE-TDD (SC-FDMA, 100% RB, 5 MHz, 16-QAM)	X	5.23	74.84	20.67	3.98	65.0	± 9.6 %
		Y	6.17	77.78	22.23		65.0	
		Z	4.36	72.33	19.08		65.0	
10263-CAD	LTE-TDD (SC-FDMA, 100% RB, 5 MHz, 64-QAM)	X	5.00	72.78	19.40	3.98	65.0	± 9.6 %
		Y	5.82	75.36	20.86		65.0	
		Z	4.18	70.40	17.80		65.0	
10264-CAD	LTE-TDD (SC-FDMA, 100% RB, 5 MHz, QPSK)	X	5.99	79.77	22.28	3.98	65.0	± 9.6 %
		Y	8.01	84.91	24.53		65.0	
		Z	4.60	75.96	20.33		65.0	
10265-CAD	LTE-TDD (SC-FDMA, 100% RB, 10 MHz, 16-QAM)	X	5.22	72.48	19.71	3.98	65.0	± 9.6 %
		Y	5.95	74.75	20.92		65.0	
		Z	4.50	70.47	18.46		65.0	
10266-CAD	LTE-TDD (SC-FDMA, 100% RB, 10 MHz, 64-QAM)	X	5.58	73.47	20.51	3.98	65.0	± 9.6 %
		Y	6.31	75.64	21.86		65.0	
		Z	4.84	71.56	19.34		65.0	
10267-CAD	LTE-TDD (SC-FDMA, 100% RB, 10 MHz, QPSK)	X	5.96	77.19	21.32	3.98	65.0	± 9.6 %
		Y	7.32	80.74	22.92		65.0	
		Z	4.89	74.49	19.94		65.0	
10268-CAD	LTE-TDD (SC-FDMA, 100% RB, 15 MHz, 16-QAM)	X	5.86	72.46	20.12	3.98	65.0	± 9.6 %
		Y	6.50	74.30	21.07		65.0	
		Z	5.17	70.78	19.12		65.0	
10269-CAD	LTE-TDD (SC-FDMA, 100% RB, 15 MHz, 64-QAM)	X	5.85	72.07	19.99	3.98	65.0	± 9.6 %
		Y	6.45	73.79	20.90		65.0	
		Z	5.20	70.49	19.02		65.0	
10270-CAD	LTE-TDD (SC-FDMA, 100% RB, 15 MHz, QPSK)	X	5.90	74.56	20.37	3.98	65.0	± 9.6 %
		Y	6.79	76.97	21.51		65.0	
		Z	5.10	72.64	19.34		65.0	

Certificate No: EX3-3847_Apr18

Page 22 of 39



EX3DV4- SN:3847

April 26, 2018

10274-CAB	UMTS-FDD (HSUPA, Subtest 5, 3GPP Rel8.10)	X	2.40	65.40	14.29	0.00	150.0	± 9.6 %
		Y	2.57	66.37	15.17		150.0	
		Z	2.31	65.52	14.03		150.0	
10275-CAB	UMTS-FDD (HSUPA, Subtest 5, 3GPP Rel8.4)	X	1.36	65.36	13.69	0.00	150.0	± 9.6 %
		Y	1.59	67.74	15.42		150.0	
		Z	1.29	65.34	13.47		150.0	
10277-CAA	PHS (QPSK)	X	1.85	60.83	6.42	9.03	50.0	± 9.6 %
		Y	2.01	61.72	7.25		50.0	
		Z	1.60	59.63	5.11		50.0	
10278-CAA	PHS (QPSK, BW 884MHz, Rolloff 0.5)	X	4.34	71.93	15.03	9.03	50.0	± 9.6 %
		Y	11.08	86.38	21.21		50.0	
		Z	2.79	65.32	10.81		50.0	
10279-CAA	PHS (QPSK, BW 884MHz, Rolloff 0.38)	X	4.48	72.29	15.25	9.03	50.0	± 9.6 %
		Y	11.33	86.65	21.37		50.0	
		Z	2.86	65.56	10.99		50.0	
10290-AAB	CDMA2000, RC1, SO55, Full Rate	X	0.98	63.94	10.60	0.00	150.0	± 9.6 %
		Y	1.42	68.39	13.82		150.0	
		Z	0.76	62.34	8.84		150.0	
10291-AAB	CDMA2000, RC3, SO55, Full Rate	X	0.58	61.91	9.15	0.00	150.0	± 9.6 %
		Y	0.80	65.42	12.22		150.0	
		Z	0.47	60.79	7.58		150.0	
10292-AAB	CDMA2000, RC3, SO32, Full Rate	X	0.64	63.49	10.34	0.00	150.0	± 9.6 %
		Y	1.03	69.64	14.66		150.0	
		Z	0.51	62.18	8.67		150.0	
10293-AAB	CDMA2000, RC3, SO3, Full Rate	X	0.79	65.91	12.03	0.00	150.0	± 9.6 %
		Y	1.64	76.28	17.94		150.0	
		Z	0.64	64.53	10.36		150.0	
10295-AAB	CDMA2000, RC1, SO3, 1/8th Rate 25 fr.	X	12.08	90.23	25.40	9.03	50.0	± 9.6 %
		Y	12.75	93.47	27.54		50.0	
		Z	11.32	86.31	22.48		50.0	
10297-AAC	LTE-FDD (SC-FDMA, 50% RB, 20 MHz, QPSK)	X	2.43	67.64	15.32	0.00	150.0	± 9.6 %
		Y	2.74	69.57	16.50		150.0	
		Z	2.31	67.56	15.25		150.0	
10298-AAC	LTE-FDD (SC-FDMA, 50% RB, 3 MHz, QPSK)	X	1.18	64.09	11.41	0.00	150.0	± 9.6 %
		Y	1.55	67.50	14.03		150.0	
		Z	0.97	62.82	9.94		150.0	
10299-AAC	LTE-FDD (SC-FDMA, 50% RB, 3 MHz, 16-QAM)	X	2.07	66.50	12.33	0.00	150.0	± 9.6 %
		Y	2.53	69.04	14.02		150.0	
		Z	1.48	63.79	10.06		150.0	
10300-AAC	LTE-FDD (SC-FDMA, 50% RB, 3 MHz, 64-QAM)	X	1.66	63.31	10.01	0.00	150.0	± 9.6 %
		Y	1.93	64.84	11.28		150.0	
		Z	1.23	61.38	8.04		150.0	
10301-AAA	IEEE 802.16e WiMAX (29:18, 5ms, 10MHz, QPSK, PUSC)	X	4.64	65.27	17.18	4.17	50.0	± 9.6 %
		Y	4.80	65.55	17.49		50.0	
		Z	4.29	64.63	16.64		50.0	
10302-AAA	IEEE 802.16e WiMAX (29:18, 5ms, 10MHz, QPSK, PUSC, 3 CTRL symbols)	X	5.09	65.68	17.78	4.96	50.0	± 9.6 %
		Y	5.28	66.19	18.23		50.0	
		Z	4.79	65.34	17.40		50.0	

Certificate No: EX3-3847_Apr18

Page 23 of 39



EX3DV4- SN:3847

April 26, 2018

10303-AAA	IEEE 802.16e WiMAX (31:15, 5ms, 10MHz, 64QAM, PUSC)	X	4.83	65.30	17.59	4.96	50.0	± 9.6 %
		Y	5.03	65.83	18.07		50.0	
		Z	4.55	64.95	17.17		50.0	
10304-AAA	IEEE 802.16e WiMAX (29:18, 5ms, 10MHz, 64QAM, PUSC)	X	4.64	65.15	17.06	4.17	50.0	± 9.6 %
		Y	4.83	65.68	17.54		50.0	
		Z	4.37	64.87	16.70		50.0	
10305-AAA	IEEE 802.16e WiMAX (31:15, 10ms, 10MHz, 64QAM, PUSC, 15 symbols)	X	4.28	67.14	19.04	6.02	35.0	± 9.6 %
		Y	4.42	67.52	19.68		35.0	
		Z	3.97	66.44	18.16		35.0	
10306-AAA	IEEE 802.16e WiMAX (29:18, 10ms, 10MHz, 64QAM, PUSC, 18 symbols)	X	4.60	66.26	18.77	6.02	35.0	± 9.6 %
		Y	4.75	66.58	19.26		35.0	
		Z	4.32	65.78	18.11		35.0	
10307-AAA	IEEE 802.16e WiMAX (29:18, 10ms, 10MHz, QPSK, PUSC, 18 symbols)	X	4.49	66.36	18.69	6.02	35.0	± 9.6 %
		Y	4.65	66.76	19.23		35.0	
		Z	4.20	65.78	17.99		35.0	
10308-AAA	IEEE 802.16e WiMAX (29:18, 10ms, 10MHz, 16QAM, PUSC)	X	4.47	66.56	18.83	6.02	35.0	± 9.6 %
		Y	4.62	66.94	19.37		35.0	
		Z	4.17	65.96	18.12		35.0	
10309-AAA	IEEE 802.16e WiMAX (29:18, 10ms, 10MHz, 16QAM, AMC 2x3, 18 symbols)	X	4.65	66.45	18.90	6.02	35.0	± 9.6 %
		Y	4.81	66.83	19.42		35.0	
		Z	4.34	65.87	18.21		35.0	
10310-AAA	IEEE 802.16e WiMAX (29:18, 10ms, 10MHz, QPSK, AMC 2x3, 18 symbols)	X	4.55	66.31	18.74	6.02	35.0	± 9.6 %
		Y	4.69	66.64	19.23		35.0	
		Z	4.27	65.82	18.09		35.0	
10311-AAC	LTE-FDD (SC-FDMA, 100% RB, 15 MHz, QPSK)	X	2.77	67.02	15.08	0.00	150.0	± 9.6 %
		Y	3.10	68.87	16.16		150.0	
		Z	2.65	66.93	15.04		150.0	
10313-AAA	iDEN 1:3	X	3.09	72.60	16.00	6.99	70.0	± 9.6 %
		Y	6.49	82.69	20.03		70.0	
		Z	2.00	67.75	13.58		70.0	
10314-AAA	iDEN 1:6	X	4.75	81.28	22.32	10.00	30.0	± 9.6 %
		Y	11.83	97.36	28.06		30.0	
		Z	3.21	74.69	19.28		30.0	
10315-AAB	IEEE 802.11b WiFi 2.4 GHz (DSSS, 1 Mbps, 96pc duty cycle)	X	0.98	62.24	13.79	0.17	150.0	± 9.6 %
		Y	1.06	63.68	15.14		150.0	
		Z	0.95	62.14	13.61		150.0	
10316-AAB	IEEE 802.11g WiFi 2.4 GHz (ERP-OFDM, 6 Mbps, 96pc duty cycle)	X	4.45	66.23	15.96	0.17	150.0	± 9.6 %
		Y	4.58	66.64	16.29		150.0	
		Z	4.30	66.23	15.82		150.0	
10317-AAC	IEEE 802.11a WiFi 5 GHz (OFDM, 6 Mbps, 96pc duty cycle)	X	4.45	66.23	15.96	0.17	150.0	± 9.6 %
		Y	4.58	66.64	16.29		150.0	
		Z	4.30	66.23	15.82		150.0	
10400-AAD	IEEE 802.11ac WiFi (20MHz, 64-QAM, 99pc duty cycle)	X	4.53	66.49	15.91	0.00	150.0	± 9.6 %
		Y	4.69	66.93	16.23		150.0	
		Z	4.37	66.51	15.82		150.0	
10401-AAD	IEEE 802.11ac WiFi (40MHz, 64-QAM, 99pc duty cycle)	X	5.30	66.87	16.22	0.00	150.0	± 9.6 %
		Y	5.38	67.11	16.39		150.0	
		Z	5.06	66.49	15.95		150.0	

Certificate No: EX3-3847_Apr18

Page 24 of 39



EX3DV4- SN:3847

April 26, 2018

10402-AAD	IEEE 802.11ac WiFi (80MHz, 64-QAM, 99pc duty cycle)	X	5.51	67.03	16.16	0.00	150.0	± 9.6 %
		Y	5.63	67.43	16.40		150.0	
		Z	5.39	67.01	16.11		150.0	
10403-AAB	CDMA2000 (1xEV-DO, Rev. 0)	X	0.98	63.94	10.60	0.00	115.0	± 9.6 %
		Y	1.42	68.39	13.82		115.0	
		Z	0.76	62.34	8.84		115.0	
10404-AAB	CDMA2000 (1xEV-DO, Rev. A)	X	0.98	63.94	10.60	0.00	115.0	± 9.6 %
		Y	1.42	68.39	13.82		115.0	
		Z	0.76	62.34	8.84		115.0	
10406-AAB	CDMA2000, RC3, SO32, SCH0, Full Rate	X	10.48	91.04	22.47	0.00	100.0	± 9.6 %
		Y	46.29	111.17	27.84		100.0	
		Z	25.97	104.14	25.39		100.0	
10410-AAD	LTE-TDD (SC-FDMA, 1 RB, 10 MHz, QPSK, UL Subframe=2,3,4,7,8,9, Subframe Conf=4)	X	100.00	126.02	31.95	3.23	80.0	± 9.6 %
		Y	100.00	125.13	31.67		80.0	
		Z	6.89	90.42	22.44		80.0	
10415-AAA	IEEE 802.11b WiFi 2.4 GHz (DSSS, 1 Mbps, 99pc duty cycle)	X	0.92	61.60	13.26	0.00	150.0	± 9.6 %
		Y	0.99	62.83	14.50		150.0	
		Z	0.90	61.69	13.21		150.0	
10416-AAA	IEEE 802.11g WiFi 2.4 GHz (ERP-OFDM, 6 Mbps, 99pc duty cycle)	X	4.39	66.19	15.86	0.00	150.0	± 9.6 %
		Y	4.52	66.59	16.17		150.0	
		Z	4.26	66.26	15.79		150.0	
10417-AAB	IEEE 802.11a/h WiFi 5 GHz (OFDM, 6 Mbps, 99pc duty cycle)	X	4.39	66.19	15.86	0.00	150.0	± 9.6 %
		Y	4.52	66.59	16.17		150.0	
		Z	4.26	66.26	15.79		150.0	
10418-AAA	IEEE 802.11g WiFi 2.4 GHz (DSSS-OFDM, 6 Mbps, 99pc duty cycle, Long preamble)	X	4.38	66.34	15.87	0.00	150.0	± 9.6 %
		Y	4.51	66.74	16.19		150.0	
		Z	4.25	66.44	15.83		150.0	
10419-AAA	IEEE 802.11g WiFi 2.4 GHz (DSSS-OFDM, 6 Mbps, 99pc duty cycle, Short preamble)	X	4.40	66.29	15.88	0.00	150.0	± 9.6 %
		Y	4.53	66.69	16.19		150.0	
		Z	4.27	66.39	15.82		150.0	
10422-AAB	IEEE 802.11n (HT Greenfield, 7.2 Mbps, BPSK)	X	4.52	66.31	15.91	0.00	150.0	± 9.6 %
		Y	4.65	66.70	16.21		150.0	
		Z	4.38	66.38	15.85		150.0	
10423-AAB	IEEE 802.11n (HT Greenfield, 43.3 Mbps, 16-QAM)	X	4.66	66.60	16.01	0.00	150.0	± 9.6 %
		Y	4.82	67.02	16.32		150.0	
		Z	4.51	66.64	15.94		150.0	
10424-AAB	IEEE 802.11n (HT Greenfield, 72.2 Mbps, 64-QAM)	X	4.59	66.54	15.98	0.00	150.0	± 9.6 %
		Y	4.74	66.97	16.30		150.0	
		Z	4.44	66.59	15.91		150.0	
10425-AAB	IEEE 802.11n (HT Greenfield, 15 Mbps, BPSK)	X	5.21	66.90	16.23	0.00	150.0	± 9.6 %
		Y	5.34	67.27	16.47		150.0	
		Z	5.08	66.89	16.17		150.0	
10426-AAB	IEEE 802.11n (HT Greenfield, 90 Mbps, 16-QAM)	X	5.24	67.00	16.28	0.00	150.0	± 9.6 %
		Y	5.34	67.29	16.48		150.0	
		Z	5.10	66.98	16.22		150.0	



EX3DV4- SN:3847

April 26, 2018

10427-AAB	IEEE 802.11n (HT Greenfield, 150 Mbps, 64-QAM)	X	5.24	66.92	16.24	0.00	150.0	± 9.6 %
		Y	5.35	67.28	16.47		150.0	
		Z	5.06	66.77	16.11		150.0	
10430-AAB	LTE-FDD (OFDMA, 5 MHz, E-TM 3.1)	X	3.99	69.96	17.43	0.00	150.0	± 9.6 %
		Y	4.23	70.63	18.08		150.0	
		Z	3.95	70.81	17.49		150.0	
10431-AAB	LTE-FDD (OFDMA, 10 MHz, E-TM 3.1)	X	4.02	66.60	15.71	0.00	150.0	± 9.6 %
		Y	4.21	67.13	16.17		150.0	
		Z	3.85	66.67	15.55		150.0	
10432-AAB	LTE-FDD (OFDMA, 15 MHz, E-TM 3.1)	X	4.34	66.55	15.88	0.00	150.0	± 9.6 %
		Y	4.51	67.01	16.24		150.0	
		Z	4.19	66.62	15.79		150.0	
10433-AAB	LTE-FDD (OFDMA, 20 MHz, E-TM 3.1)	X	4.60	66.57	16.00	0.00	150.0	± 9.6 %
		Y	4.75	67.00	16.32		150.0	
		Z	4.45	66.62	15.93		150.0	
10434-AAA	W-CDMA (BS Test Model 1, 64 DPCH)	X	4.02	70.53	17.20	0.00	150.0	± 9.6 %
		Y	4.33	71.48	18.05		150.0	
		Z	3.94	71.25	17.09		150.0	
10435-AAC	LTE-TDD (SC-FDMA, 1 RB, 20 MHz, QPSK, UL Subframe=2,3,4,7,8,9)	X	100.00	125.79	31.84	3.23	80.0	± 9.6 %
		Y	100.00	124.91	31.56		80.0	
		Z	6.42	89.33	22.05		80.0	
10447-AAB	LTE-FDD (OFDMA, 5 MHz, E-TM 3.1, Clipping 44%)	X	3.26	66.26	14.68	0.00	150.0	± 9.6 %
		Y	3.50	67.12	15.48		150.0	
		Z	3.05	66.14	14.21		150.0	
10448-AAB	LTE-FDD (OFDMA, 10 MHz, E-TM 3.1, Clipping 44%)	X	3.87	66.37	15.56	0.00	150.0	± 9.6 %
		Y	4.04	66.91	16.02		150.0	
		Z	3.72	66.46	15.41		150.0	
10449-AAB	LTE-FDD (OFDMA, 15 MHz, E-TM 3.1, Clipping 44%)	X	4.17	66.36	15.76	0.00	150.0	± 9.6 %
		Y	4.32	66.84	16.14		150.0	
		Z	4.03	66.43	15.68		150.0	
10450-AAB	LTE-FDD (OFDMA, 20 MHz, E-TM 3.1, Clipping 44%)	X	4.38	66.32	15.83	0.00	150.0	± 9.6 %
		Y	4.51	66.77	16.17		150.0	
		Z	4.25	66.38	15.77		150.0	
10451-AAA	W-CDMA (BS Test Model 1, 64 DPCH, Clipping 44%)	X	3.10	66.18	14.10	0.00	150.0	± 9.6 %
		Y	3.39	67.28	15.10		150.0	
		Z	2.83	65.80	13.41		150.0	
10456-AAB	IEEE 802.11ac WiFi (160MHz, 64-QAM, 99pc duty cycle)	X	6.12	67.56	16.47	0.00	150.0	± 9.6 %
		Y	6.20	67.82	16.62		150.0	
		Z	6.01	67.50	16.40		150.0	
10457-AAA	UMTS-FDD (DC-HSDPA)	X	3.69	64.86	15.55	0.00	150.0	± 9.6 %
		Y	3.77	65.23	15.88		150.0	
		Z	3.62	65.01	15.50		150.0	
10458-AAA	CDMA2000 (1xEV-DO, Rev. B, 2 carriers)	X	3.62	69.52	16.34	0.00	150.0	± 9.6 %
		Y	3.97	70.72	17.44		150.0	
		Z	3.37	69.33	15.62		150.0	
10459-AAA	CDMA2000 (1xEV-DO, Rev. B, 3 carriers)	X	4.90	68.11	17.73	0.00	150.0	± 9.6 %
		Y	5.06	68.23	18.06		150.0	
		Z	4.75	68.62	17.57		150.0	

Certificate No: EX3-3847_Apr18

Page 26 of 39



EX3DV4- SN:3847

April 26, 2018

10460-AAA	UMTS-FDD (WCDMA, AMR)	X	0.69	64.19	13.09	0.00	150.0	± 9.6 %
		Y	0.87	67.85	15.85		150.0	
		Z	0.67	64.28	12.96		150.0	
10461-AAA	LTE-TDD (SC-FDMA, 1 RB, 1.4 MHz, QPSK, UL Subframe=2,3,4,7,8,9)	X	84.02	126.89	33.08	3.29	80.0	± 9.6 %
		Y	100.00	130.31	34.10		80.0	
		Z	4.28	85.78	21.95		80.0	
10462-AAA	LTE-TDD (SC-FDMA, 1 RB, 1.4 MHz, 16-QAM, UL Subframe=2,3,4,7,8,9)	X	2.52	70.62	13.63	3.23	80.0	± 9.6 %
		Y	26.21	94.19	20.52		80.0	
		Z	0.72	60.00	7.99		80.0	
10463-AAA	LTE-TDD (SC-FDMA, 1 RB, 1.4 MHz, 64-QAM, UL Subframe=2,3,4,7,8,9)	X	1.32	63.49	10.12	3.23	80.0	± 9.6 %
		Y	2.56	69.70	12.62		80.0	
		Z	0.73	60.00	7.34		80.0	
10464-AAA	LTE-TDD (SC-FDMA, 1 RB, 3 MHz, QPSK, UL Subframe=2,3,4,7,8,9)	X	71.17	121.90	31.12	3.23	80.0	± 9.6 %
		Y	100.00	127.56	32.65		80.0	
		Z	3.03	80.40	19.49		80.0	
10465-AAA	LTE-TDD (SC-FDMA, 1 RB, 3 MHz, 16-QAM, UL Subframe=2,3,4,7,8,9)	X	1.99	68.14	12.60	3.23	80.0	± 9.6 %
		Y	8.79	82.97	17.46		80.0	
		Z	0.72	60.00	7.91		80.0	
10466-AAA	LTE-TDD (SC-FDMA, 1 RB, 3 MHz, 64-QAM, UL Subframe=2,3,4,7,8,9)	X	1.21	62.65	9.67	3.23	80.0	± 9.6 %
		Y	1.99	67.25	11.63		80.0	
		Z	0.73	60.00	7.29		80.0	
10467-AAC	LTE-TDD (SC-FDMA, 1 RB, 5 MHz, QPSK, UL Subframe=2,3,4,7,8,9)	X	99.99	126.82	32.25	3.23	80.0	± 9.6 %
		Y	100.00	127.88	32.79		80.0	
		Z	3.35	81.84	20.01		80.0	
10468-AAC	LTE-TDD (SC-FDMA, 1 RB, 5 MHz, 16-QAM, UL Subframe=2,3,4,7,8,9)	X	2.11	68.77	12.88	3.23	80.0	± 9.6 %
		Y	11.17	85.45	18.18		80.0	
		Z	0.72	60.00	7.94		80.0	
10469-AAC	LTE-TDD (SC-FDMA, 1 RB, 5 MHz, 64-QAM, UL Subframe=2,3,4,7,8,9)	X	1.21	62.67	9.69	3.23	80.0	± 9.6 %
		Y	2.00	67.30	11.64		80.0	
		Z	0.73	60.00	7.29		80.0	
10470-AAC	LTE-TDD (SC-FDMA, 1 RB, 10 MHz, QPSK, UL Subframe=2,3,4,7,8,9)	X	100.00	126.85	32.25	3.23	80.0	± 9.6 %
		Y	100.00	127.92	32.80		80.0	
		Z	3.35	81.89	20.02		80.0	
10471-AAC	LTE-TDD (SC-FDMA, 1 RB, 10 MHz, 16-QAM, UL Subframe=2,3,4,7,8,9)	X	2.09	68.68	12.83	3.23	80.0	± 9.6 %
		Y	10.92	85.18	18.09		80.0	
		Z	0.72	60.00	7.93		80.0	
10472-AAC	LTE-TDD (SC-FDMA, 1 RB, 10 MHz, 64-QAM, UL Subframe=2,3,4,7,8,9)	X	1.21	62.62	9.65	3.23	80.0	± 9.6 %
		Y	1.98	67.19	11.59		80.0	
		Z	0.73	60.00	7.27		80.0	
10473-AAC	LTE-TDD (SC-FDMA, 1 RB, 15 MHz, QPSK, UL Subframe=2,3,4,7,8,9)	X	100.00	126.81	32.23	3.23	80.0	± 9.6 %
		Y	100.00	127.88	32.78		80.0	
		Z	3.34	81.80	19.99		80.0	
10474-AAC	LTE-TDD (SC-FDMA, 1 RB, 15 MHz, 16-QAM, UL Subframe=2,3,4,7,8,9)	X	2.08	68.62	12.80	3.23	80.0	± 9.6 %
		Y	10.68	84.97	18.03		80.0	
		Z	0.72	60.00	7.92		80.0	
10475-AAC	LTE-TDD (SC-FDMA, 1 RB, 15 MHz, 64-QAM, UL Subframe=2,3,4,7,8,9)	X	1.20	62.60	9.64	3.23	80.0	± 9.6 %
		Y	1.97	67.14	11.57		80.0	
		Z	0.73	60.00	7.27		80.0	



EX3DV4- SN:3847

April 26, 2018

10477-AAC	LTE-TDD (SC-FDMA, 1 RB, 20 MHz, 16-QAM, UL Subframe=2,3,4,7,8,9)	X	1.98	68.11	12.58	3.23	80.0	± 9.6 %
		Y	8.87	83.03	17.46		80.0	
		Z	0.72	60.00	7.90		80.0	
10478-AAC	LTE-TDD (SC-FDMA, 1 RB, 20 MHz, 64-QAM, UL Subframe=2,3,4,7,8,9)	X	1.20	62.55	9.61	3.23	80.0	± 9.6 %
		Y	1.95	67.03	11.51		80.0	
		Z	0.73	60.00	7.26		80.0	
10479-AAA	LTE-TDD (SC-FDMA, 50% RB, 1.4 MHz, QPSK, UL Subframe=2,3,4,7,8,9)	X	7.77	87.55	23.54	3.23	80.0	± 9.6 %
		Y	9.58	90.88	24.95		80.0	
		Z	5.34	83.01	21.38		80.0	
10480-AAA	LTE-TDD (SC-FDMA, 50% RB, 1.4 MHz, 16-QAM, UL Subframe=2,3,4,7,8,9)	X	6.80	80.27	19.12	3.23	80.0	± 9.6 %
		Y	11.20	87.21	21.75		80.0	
		Z	3.11	71.34	14.97		80.0	
10481-AAA	LTE-TDD (SC-FDMA, 50% RB, 1.4 MHz, 64-QAM, UL Subframe=2,3,4,7,8,9)	X	5.10	75.89	17.20	3.23	80.0	± 9.6 %
		Y	8.44	82.58	19.88		80.0	
		Z	2.28	67.29	12.89		80.0	
10482-AAA	LTE-TDD (SC-FDMA, 50% RB, 3 MHz, QPSK, UL Subframe=2,3,4,7,8,9)	X	2.06	67.56	14.47	2.23	80.0	± 9.6 %
		Y	3.95	76.80	19.08		80.0	
		Z	1.30	62.65	11.14		80.0	
10483-AAA	LTE-TDD (SC-FDMA, 50% RB, 3 MHz, 16-QAM, UL Subframe=2,3,4,7,8,9)	X	3.51	70.88	15.53	2.23	80.0	± 9.6 %
		Y	5.27	76.52	18.28		80.0	
		Z	1.80	63.41	11.09		80.0	
10484-AAA	LTE-TDD (SC-FDMA, 50% RB, 3 MHz, 64-QAM, UL Subframe=2,3,4,7,8,9)	X	3.27	69.73	15.05	2.23	80.0	± 9.6 %
		Y	4.79	74.98	17.71		80.0	
		Z	1.76	62.89	10.82		80.0	
10485-AAC	LTE-TDD (SC-FDMA, 50% RB, 5 MHz, QPSK, UL Subframe=2,3,4,7,8,9)	X	2.53	70.00	16.66	2.23	80.0	± 9.6 %
		Y	3.96	76.89	20.10		80.0	
		Z	1.81	66.19	14.25		80.0	
10486-AAC	LTE-TDD (SC-FDMA, 50% RB, 5 MHz, 16-QAM, UL Subframe=2,3,4,7,8,9)	X	2.57	66.81	14.63	2.23	80.0	± 9.6 %
		Y	3.53	71.42	17.33		80.0	
		Z	1.91	63.66	12.29		80.0	
10487-AAC	LTE-TDD (SC-FDMA, 50% RB, 5 MHz, 64-QAM, UL Subframe=2,3,4,7,8,9)	X	2.58	66.50	14.48	2.23	80.0	± 9.6 %
		Y	3.50	70.87	17.08		80.0	
		Z	1.93	63.45	12.16		80.0	
10488-AAC	LTE-TDD (SC-FDMA, 50% RB, 10 MHz, QPSK, UL Subframe=2,3,4,7,8,9)	X	2.94	70.04	17.55	2.23	80.0	± 9.6 %
		Y	3.91	74.55	19.82		80.0	
		Z	2.36	67.53	16.08		80.0	
10489-AAC	LTE-TDD (SC-FDMA, 50% RB, 10 MHz, 16-QAM, UL Subframe=2,3,4,7,8,9)	X	3.04	67.41	16.37	2.23	80.0	± 9.6 %
		Y	3.59	69.95	17.90		80.0	
		Z	2.60	65.85	15.19		80.0	
10490-AAC	LTE-TDD (SC-FDMA, 50% RB, 10 MHz, 64-QAM, UL Subframe=2,3,4,7,8,9)	X	3.13	67.33	16.35	2.23	80.0	± 9.6 %
		Y	3.67	69.71	17.80		80.0	
		Z	2.69	65.82	15.19		80.0	
10491-AAC	LTE-TDD (SC-FDMA, 50% RB, 15 MHz, QPSK, UL Subframe=2,3,4,7,8,9)	X	3.27	69.10	17.32	2.23	80.0	± 9.6 %
		Y	4.01	72.33	19.00		80.0	
		Z	2.76	67.20	16.22		80.0	
10492-AAC	LTE-TDD (SC-FDMA, 50% RB, 15 MHz, 16-QAM, UL Subframe=2,3,4,7,8,9)	X	3.43	66.99	16.56	2.23	80.0	± 9.6 %
		Y	3.87	68.87	17.69		80.0	
		Z	3.04	65.80	15.69		80.0	



EX3DV4- SN:3847

April 26, 2018

10493-AAC	LTE-TDD (SC-FDMA, 50% RB, 15 MHz, 64-QAM, UL Subframe=2,3,4,7,8,9)	X	3.50	65.91	16.53	2.23	80.0	± 9.6 %
		Y	3.93	68.70	17.63		80.0	
		Z	3.11	65.75	15.67		80.0	
10494-AAC	LTE-TDD (SC-FDMA, 50% RB, 20 MHz, QPSK, UL Subframe=2,3,4,7,8,9)	X	3.48	70.31	17.70	2.23	80.0	± 9.6 %
		Y	4.45	74.27	19.62		80.0	
		Z	2.88	68.11	16.53		80.0	
10495-AAC	LTE-TDD (SC-FDMA, 50% RB, 20 MHz, 16-QAM, UL Subframe=2,3,4,7,8,9)	X	3.45	67.28	16.74	2.23	80.0	± 9.6 %
		Y	3.91	69.30	17.91		80.0	
		Z	3.05	66.01	15.88		80.0	
10496-AAC	LTE-TDD (SC-FDMA, 50% RB, 20 MHz, 64-QAM, UL Subframe=2,3,4,7,8,9)	X	3.54	67.10	16.70	2.23	80.0	± 9.6 %
		Y	3.98	68.96	17.79		80.0	
		Z	3.15	65.93	15.88		80.0	
10497-AAA	LTE-TDD (SC-FDMA, 100% RB, 1.4 MHz, QPSK, UL Subframe=2,3,4,7,8,9)	X	1.40	62.99	11.15	2.23	80.0	± 9.6 %
		Y	2.90	72.22	16.27		80.0	
		Z	0.97	60.00	8.34		80.0	
10498-AAA	LTE-TDD (SC-FDMA, 100% RB, 1.4 MHz, 16-QAM, UL Subframe=2,3,4,7,8,9)	X	1.29	60.00	8.48	2.23	80.0	± 9.6 %
		Y	1.88	63.90	11.46		80.0	
		Z	1.15	60.00	7.19		80.0	
10499-AAA	LTE-TDD (SC-FDMA, 100% RB, 1.4 MHz, 64-QAM, UL Subframe=2,3,4,7,8,9)	X	1.30	60.00	8.33	2.23	80.0	± 9.6 %
		Y	1.80	63.11	10.92		80.0	
		Z	1.16	60.00	7.04		80.0	
10500-AAA	LTE-TDD (SC-FDMA, 100% RB, 3 MHz, QPSK, UL Subframe=2,3,4,7,8,9)	X	2.68	69.88	16.98	2.23	80.0	± 9.6 %
		Y	3.82	75.38	19.79		80.0	
		Z	2.04	66.78	15.02		80.0	
10501-AAA	LTE-TDD (SC-FDMA, 100% RB, 3 MHz, 16-QAM, UL Subframe=2,3,4,7,8,9)	X	2.79	67.24	15.39	2.23	80.0	± 9.6 %
		Y	3.56	70.81	17.54		80.0	
		Z	2.22	64.82	13.55		80.0	
10502-AAA	LTE-TDD (SC-FDMA, 100% RB, 3 MHz, 64-QAM, UL Subframe=2,3,4,7,8,9)	X	2.85	67.13	15.27	2.23	80.0	± 9.6 %
		Y	3.61	70.61	17.39		80.0	
		Z	2.26	64.72	13.43		80.0	
10503-AAC	LTE-TDD (SC-FDMA, 100% RB, 5 MHz, QPSK, UL Subframe=2,3,4,7,8,9)	X	2.91	69.86	17.46	2.23	80.0	± 9.6 %
		Y	3.86	74.33	19.71		80.0	
		Z	2.34	67.37	15.99		80.0	
10504-AAC	LTE-TDD (SC-FDMA, 100% RB, 5 MHz, 16-QAM, UL Subframe=2,3,4,7,8,9)	X	3.02	67.33	16.31	2.23	80.0	± 9.6 %
		Y	3.57	69.86	17.85		80.0	
		Z	2.59	65.76	15.13		80.0	
10505-AAC	LTE-TDD (SC-FDMA, 100% RB, 5 MHz, 64-QAM, UL Subframe=2,3,4,7,8,9)	X	3.12	67.25	16.29	2.23	80.0	± 9.6 %
		Y	3.65	69.61	17.75		80.0	
		Z	2.68	65.74	15.13		80.0	
10506-AAC	LTE-TDD (SC-FDMA, 100% RB, 10 MHz, QPSK, UL Subframe=2,3,4,7,8,9)	X	3.45	70.18	17.63	2.23	80.0	± 9.6 %
		Y	4.41	74.11	19.54		80.0	
		Z	2.87	68.00	16.46		80.0	
10507-AAC	LTE-TDD (SC-FDMA, 100% RB, 10 MHz, 16-QAM, UL Subframe=2,3,4,7,8,9)	X	3.44	67.22	16.70	2.23	80.0	± 9.6 %
		Y	3.90	69.24	17.87		80.0	
		Z	3.04	65.96	15.84		80.0	



EX3DV4- SN:3847

April 26, 2018

10508-AAC	LTE-TDD (SC-FDMA, 100% RB, 10 MHz, 64-QAM, UL Subframe=2,3,4,7,8,9)	X	3.53	67.04	16.65	2.23	80.0	± 9.6 %
		Y	3.97	68.89	17.74		80.0	
		Z	3.14	65.87	15.84		80.0	
10509-AAC	LTE-TDD (SC-FDMA, 100% RB, 15 MHz, QPSK, UL Subframe=2,3,4,7,8,9)	X	3.87	69.40	17.33	2.23	80.0	± 9.6 %
		Y	4.64	72.32	18.78		80.0	
		Z	3.35	67.73	16.42		80.0	
10510-AAC	LTE-TDD (SC-FDMA, 100% RB, 15 MHz, 16-QAM, UL Subframe=2,3,4,7,8,9)	X	3.94	67.14	16.80	2.23	80.0	± 9.6 %
		Y	4.36	68.82	17.75		80.0	
		Z	3.55	66.05	16.10		80.0	
10511-AAC	LTE-TDD (SC-FDMA, 100% RB, 15 MHz, 64-QAM, UL Subframe=2,3,4,7,8,9)	X	4.00	66.96	16.76	2.23	80.0	± 9.6 %
		Y	4.40	68.51	17.65		80.0	
		Z	3.63	65.95	16.09		80.0	
10512-AAC	LTE-TDD (SC-FDMA, 100% RB, 20 MHz, QPSK, UL Subframe=2,3,4,7,8,9)	X	3.95	70.58	17.67	2.23	80.0	± 9.6 %
		Y	4.99	74.37	19.46		80.0	
		Z	3.34	68.50	16.61		80.0	
10513-AAC	LTE-TDD (SC-FDMA, 100% RB, 20 MHz, 16-QAM, UL Subframe=2,3,4,7,8,9)	X	3.81	67.30	16.87	2.23	80.0	± 9.6 %
		Y	4.26	69.16	17.90		80.0	
		Z	3.43	66.10	16.12		80.0	
10514-AAC	LTE-TDD (SC-FDMA, 100% RB, 20 MHz, 64-QAM, UL Subframe=2,3,4,7,8,9)	X	3.86	66.98	16.78	2.23	80.0	± 9.6 %
		Y	4.26	68.66	17.73		80.0	
		Z	3.49	65.88	16.08		80.0	
10515-AAA	IEEE 802.11b WiFi 2.4 GHz (DSSS, 2 Mbps, 99pc duty cycle)	X	0.88	61.68	13.23	0.00	150.0	± 9.6 %
		Y	0.95	63.01	14.55		150.0	
		Z	0.86	61.76	13.18		150.0	
10516-AAA	IEEE 802.11b WiFi 2.4 GHz (DSSS, 5.5 Mbps, 99pc duty cycle)	X	0.40	64.17	12.55	0.00	150.0	± 9.6 %
		Y	0.57	69.89	16.83		150.0	
		Z	0.39	64.39	12.59		150.0	
10517-AAA	IEEE 802.11b WiFi 2.4 GHz (DSSS, 11 Mbps, 99pc duty cycle)	X	0.70	62.60	13.12	0.00	150.0	± 9.6 %
		Y	0.80	64.84	15.10		150.0	
		Z	0.68	62.64	13.06		150.0	
10518-AAB	IEEE 802.11a/h WiFi 5 GHz (OFDM, 9 Mbps, 99pc duty cycle)	X	4.38	66.26	15.83	0.00	150.0	± 9.6 %
		Y	4.52	66.66	16.15		150.0	
		Z	4.25	66.35	15.77		150.0	
10519-AAB	IEEE 802.11a/h WiFi 5 GHz (OFDM, 12 Mbps, 99pc duty cycle)	X	4.55	66.48	15.95	0.00	150.0	± 9.6 %
		Y	4.70	66.90	16.27		150.0	
		Z	4.40	66.53	15.87		150.0	
10520-AAB	IEEE 802.11a/h WiFi 5 GHz (OFDM, 18 Mbps, 99pc duty cycle)	X	4.40	66.40	15.85	0.00	150.0	± 9.6 %
		Y	4.55	66.86	16.19		150.0	
		Z	4.25	66.44	15.77		150.0	
10521-AAB	IEEE 802.11a/h WiFi 5 GHz (OFDM, 24 Mbps, 99pc duty cycle)	X	4.33	66.38	15.82	0.00	150.0	± 9.6 %
		Y	4.49	66.85	16.17		150.0	
		Z	4.18	66.40	15.74		150.0	
10522-AAB	IEEE 802.11a/h WiFi 5 GHz (OFDM, 36 Mbps, 99pc duty cycle)	X	4.39	66.51	15.93	0.00	150.0	± 9.6 %
		Y	4.55	66.94	16.26		150.0	
		Z	4.24	66.53	15.84		150.0	

Certificate No: EX3-3847_Apr18

Page 30 of 39



EX3DV4- SN:3847

April 26, 2018

10523-AAB	IEEE 802.11a/h WiFi 5 GHz (OFDM, 48 Mbps, 99pc duty cycle)	X	4.28	66.38	15.77	0.00	150.0	± 9.6 %
		Y	4.43	66.81	16.11		150.0	
		Z	4.16	66.50	15.74		150.0	
10524-AAB	IEEE 802.11a/h WiFi 5 GHz (OFDM, 54 Mbps, 99pc duty cycle)	X	4.34	66.42	15.89	0.00	150.0	± 9.6 %
		Y	4.49	66.86	16.23		150.0	
		Z	4.19	66.48	15.82		150.0	
10525-AAB	IEEE 802.11ac WiFi (20MHz, MCS0, 99pc duty cycle)	X	4.34	65.48	15.49	0.00	150.0	± 9.6 %
		Y	4.48	65.91	15.82		150.0	
		Z	4.21	65.58	15.45		150.0	
10526-AAB	IEEE 802.11ac WiFi (20MHz, MCS1, 99pc duty cycle)	X	4.48	65.81	15.63	0.00	150.0	± 9.6 %
		Y	4.64	66.28	15.96		150.0	
		Z	4.33	65.85	15.56		150.0	
10527-AAB	IEEE 802.11ac WiFi (20MHz, MCS2, 99pc duty cycle)	X	4.41	65.75	15.56	0.00	150.0	± 9.6 %
		Y	4.56	66.24	15.91		150.0	
		Z	4.26	65.81	15.49		150.0	
10528-AAB	IEEE 802.11ac WiFi (20MHz, MCS3, 99pc duty cycle)	X	4.42	65.77	15.59	0.00	150.0	± 9.6 %
		Y	4.58	66.25	15.94		150.0	
		Z	4.28	65.82	15.53		150.0	
10529-AAB	IEEE 802.11ac WiFi (20MHz, MCS4, 99pc duty cycle)	X	4.42	65.77	15.59	0.00	150.0	± 9.6 %
		Y	4.58	66.25	15.94		150.0	
		Z	4.28	65.82	15.53		150.0	
10531-AAB	IEEE 802.11ac WiFi (20MHz, MCS6, 99pc duty cycle)	X	4.40	65.83	15.58	0.00	150.0	± 9.6 %
		Y	4.57	66.36	15.95		150.0	
		Z	4.24	65.84	15.50		150.0	
10532-AAB	IEEE 802.11ac WiFi (20MHz, MCS7, 99pc duty cycle)	X	4.27	65.68	15.50	0.00	150.0	± 9.6 %
		Y	4.43	66.21	15.88		150.0	
		Z	4.12	65.69	15.42		150.0	
10533-AAB	IEEE 802.11ac WiFi (20MHz, MCS8, 99pc duty cycle)	X	4.43	65.83	15.58	0.00	150.0	± 9.6 %
		Y	4.59	66.30	15.93		150.0	
		Z	4.28	65.89	15.53		150.0	
10534-AAB	IEEE 802.11ac WiFi (40MHz, MCS0, 99pc duty cycle)	X	4.98	65.93	15.72	0.00	150.0	± 9.6 %
		Y	5.11	66.36	16.00		150.0	
		Z	4.85	65.93	15.67		150.0	
10535-AAB	IEEE 802.11ac WiFi (40MHz, MCS1, 99pc duty cycle)	X	5.05	66.13	15.81	0.00	150.0	± 9.6 %
		Y	5.18	66.53	16.07		150.0	
		Z	4.89	66.06	15.74		150.0	
10536-AAB	IEEE 802.11ac WiFi (40MHz, MCS2, 99pc duty cycle)	X	4.92	66.06	15.75	0.00	150.0	± 9.6 %
		Y	5.05	66.49	16.03		150.0	
		Z	4.78	66.04	15.70		150.0	
10537-AAB	IEEE 802.11ac WiFi (40MHz, MCS3, 99pc duty cycle)	X	4.97	66.03	15.75	0.00	150.0	± 9.6 %
		Y	5.11	66.45	16.02		150.0	
		Z	4.85	66.05	15.71		150.0	
10538-AAB	IEEE 802.11ac WiFi (40MHz, MCS4, 99pc duty cycle)	X	5.06	66.05	15.80	0.00	150.0	± 9.6 %
		Y	5.20	66.48	16.07		150.0	
		Z	4.92	66.03	15.74		150.0	
10540-AAB	IEEE 802.11ac WiFi (40MHz, MCS6, 99pc duty cycle)	X	4.99	66.04	15.81	0.00	150.0	± 9.6 %
		Y	5.13	66.49	16.09		150.0	
		Z	4.84	65.97	15.73		150.0	

Certificate No: EX3-3847_Apr18

Page 31 of 39



EX3DV4- SN:3847

April 26, 2018

10541-AAB	IEEE 802.11ac WiFi (40MHz, MCS7, 99pc duty cycle)	X	4.97	65.92	15.74	0.00	150.0	± 9.6 %
		Y	5.10	66.36	16.02		150.0	
		Z	4.83	65.89	15.67		150.0	
10542-AAB	IEEE 802.11ac WiFi (40MHz, MCS8, 99pc duty cycle)	X	5.13	66.03	15.81	0.00	150.0	± 9.6 %
		Y	5.26	66.43	16.07		150.0	
		Z	4.99	66.01	15.75		150.0	
10543-AAB	IEEE 802.11ac WiFi (40MHz, MCS9, 99pc duty cycle)	X	5.19	66.05	15.85	0.00	150.0	± 9.6 %
		Y	5.33	66.46	16.11		150.0	
		Z	5.06	66.10	15.83		150.0	
10544-AAB	IEEE 802.11ac WiFi (80MHz, MCS0, 99pc duty cycle)	X	5.31	66.07	15.75	0.00	150.0	± 9.6 %
		Y	5.42	66.48	16.00		150.0	
		Z	5.20	66.05	15.70		150.0	
10545-AAB	IEEE 802.11ac WiFi (80MHz, MCS1, 99pc duty cycle)	X	5.50	66.52	15.93	0.00	150.0	± 9.6 %
		Y	5.61	66.88	16.14		150.0	
		Z	5.38	66.50	15.88		150.0	
10546-AAB	IEEE 802.11ac WiFi (80MHz, MCS2, 99pc duty cycle)	X	5.36	66.24	15.80	0.00	150.0	± 9.6 %
		Y	5.49	66.69	16.06		150.0	
		Z	5.23	66.17	15.72		150.0	
10547-AAB	IEEE 802.11ac WiFi (80MHz, MCS3, 99pc duty cycle)	X	5.44	66.31	15.83	0.00	150.0	± 9.6 %
		Y	5.56	66.72	16.07		150.0	
		Z	5.32	66.29	15.78		150.0	
10548-AAB	IEEE 802.11ac WiFi (80MHz, MCS4, 99pc duty cycle)	X	5.66	67.18	16.24	0.00	150.0	± 9.6 %
		Y	5.79	67.60	16.49		150.0	
		Z	5.46	66.91	16.07		150.0	
10550-AAB	IEEE 802.11ac WiFi (80MHz, MCS6, 99pc duty cycle)	X	5.41	66.34	15.86	0.00	150.0	± 9.6 %
		Y	5.51	66.70	16.08		150.0	
		Z	5.30	66.37	15.84		150.0	
10551-AAB	IEEE 802.11ac WiFi (80MHz, MCS7, 99pc duty cycle)	X	5.39	66.30	15.80	0.00	150.0	± 9.6 %
		Y	5.52	66.75	16.06		150.0	
		Z	5.23	66.13	15.69		150.0	
10552-AAB	IEEE 802.11ac WiFi (80MHz, MCS8, 99pc duty cycle)	X	5.32	66.13	15.72	0.00	150.0	± 9.6 %
		Y	5.44	66.55	15.98		150.0	
		Z	5.21	66.15	15.69		150.0	
10553-AAB	IEEE 802.11ac WiFi (80MHz, MCS9, 99pc duty cycle)	X	5.39	66.15	15.77	0.00	150.0	± 9.6 %
		Y	5.52	66.59	16.02		150.0	
		Z	5.26	66.11	15.71		150.0	
10554-AAC	IEEE 802.11ac WiFi (160MHz, MCS0, 99pc duty cycle)	X	5.73	66.46	15.86	0.00	150.0	± 9.6 %
		Y	5.83	66.84	16.08		150.0	
		Z	5.63	66.41	15.80		150.0	
10555-AAC	IEEE 802.11ac WiFi (160MHz, MCS1, 99pc duty cycle)	X	5.85	66.75	15.99	0.00	150.0	± 9.6 %
		Y	5.95	67.13	16.21		150.0	
		Z	5.72	66.64	15.90		150.0	
10556-AAC	IEEE 802.11ac WiFi (160MHz, MCS2, 99pc duty cycle)	X	5.88	66.80	16.01	0.00	150.0	± 9.6 %
		Y	5.97	67.18	16.22		150.0	
		Z	5.76	66.75	15.95		150.0	
10557-AAC	IEEE 802.11ac WiFi (160MHz, MCS3, 99pc duty cycle)	X	5.83	66.68	15.96	0.00	150.0	± 9.6 %
		Y	5.94	67.09	16.20		150.0	
		Z	5.71	66.61	15.89		150.0	

Certificate No: EX3-3847_Apr18

Page 32 of 39



EX3DV4- SN:3847

April 26, 2018

10558-AAC	IEEE 802.11ac WiFi (160MHz, MCS4, 99pc duty cycle)	X	5.87	66.83	16.05	0.00	150.0	± 9.6 %
		Y	5.99	67.25	16.29		150.0	
		Z	5.72	66.67	15.94		150.0	
10560-AAC	IEEE 802.11ac WiFi (160MHz, MCS6, 99pc duty cycle)	X	5.87	66.69	16.02	0.00	150.0	± 9.6 %
		Y	5.99	67.11	16.26		150.0	
		Z	5.74	66.60	15.95		150.0	
10561-AAC	IEEE 802.11ac WiFi (160MHz, MCS7, 99pc duty cycle)	X	5.80	66.68	16.05	0.00	150.0	± 9.6 %
		Y	5.91	67.07	16.28		150.0	
		Z	5.68	66.59	15.97		150.0	
10562-AAC	IEEE 802.11ac WiFi (160MHz, MCS8, 99pc duty cycle)	X	5.89	66.97	16.19	0.00	150.0	± 9.6 %
		Y	6.03	67.44	16.47		150.0	
		Z	5.73	66.75	16.05		150.0	
10563-AAC	IEEE 802.11ac WiFi (160MHz, MCS9, 99pc duty cycle)	X	6.00	66.93	16.14	0.00	150.0	± 9.6 %
		Y	6.25	67.71	16.56		150.0	
		Z	5.83	66.74	16.01		150.0	
10564-AAA	IEEE 802.11g WiFi 2.4 GHz (DSSS-OFDM, 9 Mbps, 99pc duty cycle)	X	4.71	66.38	16.03	0.46	150.0	± 9.6 %
		Y	4.84	66.75	16.32		150.0	
		Z	4.57	66.42	15.94		150.0	
10565-AAA	IEEE 802.11g WiFi 2.4 GHz (DSSS-OFDM, 12 Mbps, 99pc duty cycle)	X	4.92	66.81	16.35	0.46	150.0	± 9.6 %
		Y	5.07	67.20	16.64		150.0	
		Z	4.77	66.84	16.26		150.0	
10566-AAA	IEEE 802.11g WiFi 2.4 GHz (DSSS-OFDM, 18 Mbps, 99pc duty cycle)	X	4.76	66.63	16.15	0.46	150.0	± 9.6 %
		Y	4.91	67.05	16.46		150.0	
		Z	4.60	66.62	16.04		150.0	
10567-AAA	IEEE 802.11g WiFi 2.4 GHz (DSSS-OFDM, 24 Mbps, 99pc duty cycle)	X	4.78	67.00	16.50	0.46	150.0	± 9.6 %
		Y	4.93	67.43	16.81		150.0	
		Z	4.63	67.04	16.43		150.0	
10568-AAA	IEEE 802.11g WiFi 2.4 GHz (DSSS-OFDM, 36 Mbps, 99pc duty cycle)	X	4.67	66.41	15.92	0.46	150.0	± 9.6 %
		Y	4.82	66.83	16.24		150.0	
		Z	4.50	66.35	15.77		150.0	
10569-AAA	IEEE 802.11g WiFi 2.4 GHz (DSSS-OFDM, 48 Mbps, 99pc duty cycle)	X	4.75	67.13	16.58	0.46	150.0	± 9.6 %
		Y	4.89	67.52	16.87		150.0	
		Z	4.62	67.25	16.56		150.0	
10570-AAA	IEEE 802.11g WiFi 2.4 GHz (DSSS-OFDM, 54 Mbps, 99pc duty cycle)	X	4.78	66.97	16.51	0.46	150.0	± 9.6 %
		Y	4.92	67.36	16.80		150.0	
		Z	4.62	67.04	16.45		150.0	
10571-AAA	IEEE 802.11b WiFi 2.4 GHz (DSSS, 1 Mbps, 90pc duty cycle)	X	1.04	62.72	14.15	0.46	130.0	± 9.6 %
		Y	1.14	64.34	15.57		130.0	
		Z	0.99	62.38	13.79		130.0	
10572-AAA	IEEE 802.11b WiFi 2.4 GHz (DSSS, 2 Mbps, 90pc duty cycle)	X	1.04	63.14	14.42	0.46	130.0	± 9.6 %
		Y	1.15	64.90	15.93		130.0	
		Z	0.99	62.76	14.05		130.0	
10573-AAA	IEEE 802.11b WiFi 2.4 GHz (DSSS, 5.5 Mbps, 90pc duty cycle)	X	0.81	70.70	16.26	0.46	130.0	± 9.6 %
		Y	2.14	87.31	23.95		130.0	
		Z	0.66	68.79	15.25		130.0	
10574-AAA	IEEE 802.11b WiFi 2.4 GHz (DSSS, 11 Mbps, 90pc duty cycle)	X	1.02	66.72	16.25	0.46	130.0	± 9.6 %
		Y	1.26	70.66	18.88		130.0	
		Z	0.94	66.05	15.78		130.0	

Certificate No: EX3-3847_Apr18

Page 33 of 39



EX3DV4- SN:3847

April 26, 2018

10575-AAA	IEEE 802.11g WiFi 2.4 GHz (DSSS-OFDM, 6 Mbps, 90pc duty cycle)	X	4.50	66.17	16.08	0.46	130.0	± 9.6 %
		Y	4.63	66.56	16.40		130.0	
		Z	4.35	66.16	15.93		130.0	
10576-AAA	IEEE 802.11g WiFi 2.4 GHz (DSSS-OFDM, 9 Mbps, 90pc duty cycle)	X	4.52	66.33	16.14	0.46	130.0	± 9.6 %
		Y	4.66	66.72	16.46		130.0	
		Z	4.37	66.35	16.02		130.0	
10577-AAA	IEEE 802.11g WiFi 2.4 GHz (DSSS-OFDM, 12 Mbps, 90pc duty cycle)	X	4.71	66.61	16.32	0.46	130.0	± 9.6 %
		Y	4.86	67.01	16.63		130.0	
		Z	4.54	66.60	16.17		130.0	
10578-AAA	IEEE 802.11g WiFi 2.4 GHz (DSSS-OFDM, 18 Mbps, 90pc duty cycle)	X	4.60	66.74	16.40	0.46	130.0	± 9.6 %
		Y	4.76	67.17	16.73		130.0	
		Z	4.44	66.73	16.27		130.0	
10579-AAA	IEEE 802.11g WiFi 2.4 GHz (DSSS-OFDM, 24 Mbps, 90pc duty cycle)	X	4.37	65.99	15.69	0.46	130.0	± 9.6 %
		Y	4.52	66.47	16.05		130.0	
		Z	4.19	65.88	15.49		130.0	
10580-AAA	IEEE 802.11g WiFi 2.4 GHz (DSSS-OFDM, 36 Mbps, 90pc duty cycle)	X	4.42	66.07	15.73	0.46	130.0	± 9.6 %
		Y	4.57	66.51	16.08		130.0	
		Z	4.23	65.94	15.51		130.0	
10581-AAA	IEEE 802.11g WiFi 2.4 GHz (DSSS-OFDM, 48 Mbps, 90pc duty cycle)	X	4.50	66.76	16.33	0.46	130.0	± 9.6 %
		Y	4.65	67.21	16.67		130.0	
		Z	4.34	66.76	16.22		130.0	
10582-AAA	IEEE 802.11g WiFi 2.4 GHz (DSSS-OFDM, 54 Mbps, 90pc duty cycle)	X	4.31	65.77	15.48	0.46	130.0	± 9.6 %
		Y	4.47	66.23	15.84		130.0	
		Z	4.12	65.65	15.26		130.0	
10583-AAB	IEEE 802.11a/h WiFi 5 GHz (OFDM, 6 Mbps, 90pc duty cycle)	X	4.50	66.17	16.08	0.46	130.0	± 9.6 %
		Y	4.63	66.56	16.40		130.0	
		Z	4.35	66.16	15.93		130.0	
10584-AAB	IEEE 802.11a/h WiFi 5 GHz (OFDM, 9 Mbps, 90pc duty cycle)	X	4.52	66.33	16.14	0.46	130.0	± 9.6 %
		Y	4.66	66.72	16.46		130.0	
		Z	4.37	66.35	16.02		130.0	
10585-AAB	IEEE 802.11a/h WiFi 5 GHz (OFDM, 12 Mbps, 90pc duty cycle)	X	4.71	66.61	16.32	0.46	130.0	± 9.6 %
		Y	4.86	67.01	16.63		130.0	
		Z	4.54	66.60	16.17		130.0	
10586-AAB	IEEE 802.11a/h WiFi 5 GHz (OFDM, 18 Mbps, 90pc duty cycle)	X	4.60	66.74	16.40	0.46	130.0	± 9.6 %
		Y	4.76	67.17	16.73		130.0	
		Z	4.44	66.73	16.27		130.0	
10587-AAB	IEEE 802.11a/h WiFi 5 GHz (OFDM, 24 Mbps, 90pc duty cycle)	X	4.37	65.99	15.69	0.46	130.0	± 9.6 %
		Y	4.52	66.47	16.05		130.0	
		Z	4.19	65.88	15.49		130.0	
10588-AAB	IEEE 802.11a/h WiFi 5 GHz (OFDM, 36 Mbps, 90pc duty cycle)	X	4.42	66.07	15.73	0.46	130.0	± 9.6 %
		Y	4.57	66.51	16.08		130.0	
		Z	4.23	65.94	15.51		130.0	
10589-AAB	IEEE 802.11a/h WiFi 5 GHz (OFDM, 48 Mbps, 90pc duty cycle)	X	4.50	66.76	16.33	0.46	130.0	± 9.6 %
		Y	4.65	67.21	16.67		130.0	
		Z	4.34	66.76	16.22		130.0	
10590-AAB	IEEE 802.11a/h WiFi 5 GHz (OFDM, 54 Mbps, 90pc duty cycle)	X	4.31	65.77	15.48	0.46	130.0	± 9.6 %
		Y	4.47	66.23	15.84		130.0	
		Z	4.12	65.65	15.26		130.0	

Certificate No: EX3-3847_Apr18

Page 34 of 39



EX3DV4- SN:3847

April 26, 2018

10591-AAB	IEEE 802.11n (HT Mixed, 20MHz, MCS0, 90pc duty cycle)	X	4.65	66.26	16.20	0.46	130.0	± 9.6 %
		Y	4.78	66.62	16.49		130.0	
		Z	4.51	66.28	16.08		130.0	
10592-AAB	IEEE 802.11n (HT Mixed, 20MHz, MCS1, 90pc duty cycle)	X	4.79	66.57	16.33	0.46	130.0	± 9.6 %
		Y	4.94	66.96	16.63		130.0	
		Z	4.63	66.56	16.20		130.0	
10593-AAB	IEEE 802.11n (HT Mixed, 20MHz, MCS2, 90pc duty cycle)	X	4.71	66.46	16.20	0.46	130.0	± 9.6 %
		Y	4.86	66.87	16.51		130.0	
		Z	4.54	66.42	16.05		130.0	
10594-AAB	IEEE 802.11n (HT Mixed, 20MHz, MCS3, 90pc duty cycle)	X	4.76	66.63	16.36	0.46	130.0	± 9.6 %
		Y	4.91	67.03	16.66		130.0	
		Z	4.60	66.61	16.22		130.0	
10595-AAB	IEEE 802.11n (HT Mixed, 20MHz, MCS4, 90pc duty cycle)	X	4.73	66.58	16.25	0.46	130.0	± 9.6 %
		Y	4.88	66.98	16.56		130.0	
		Z	4.56	66.57	16.12		130.0	
10596-AAB	IEEE 802.11n (HT Mixed, 20MHz, MCS5, 90pc duty cycle)	X	4.66	66.56	16.25	0.46	130.0	± 9.6 %
		Y	4.82	66.98	16.56		130.0	
		Z	4.49	66.52	16.10		130.0	
10597-AAB	IEEE 802.11n (HT Mixed, 20MHz, MCS6, 90pc duty cycle)	X	4.61	66.45	16.11	0.46	130.0	± 9.6 %
		Y	4.77	66.89	16.45		130.0	
		Z	4.44	66.39	15.95		130.0	
10598-AAB	IEEE 802.11n (HT Mixed, 20MHz, MCS7, 90pc duty cycle)	X	4.59	66.66	16.37	0.46	130.0	± 9.6 %
		Y	4.75	67.11	16.70		130.0	
		Z	4.43	66.62	16.23		130.0	
10599-AAB	IEEE 802.11n (HT Mixed, 40MHz, MCS0, 90pc duty cycle)	X	5.34	66.83	16.48	0.46	130.0	± 9.6 %
		Y	5.45	67.17	16.70		130.0	
		Z	5.20	66.82	16.39		130.0	
10600-AAB	IEEE 802.11n (HT Mixed, 40MHz, MCS1, 90pc duty cycle)	X	5.48	67.28	16.68	0.46	130.0	± 9.6 %
		Y	5.58	67.55	16.86		130.0	
		Z	5.31	67.19	16.55		130.0	
10601-AAB	IEEE 802.11n (HT Mixed, 40MHz, MCS2, 90pc duty cycle)	X	5.36	67.01	16.55	0.46	130.0	± 9.6 %
		Y	5.47	67.32	16.77		130.0	
		Z	5.21	66.95	16.45		130.0	
10602-AAB	IEEE 802.11n (HT Mixed, 40MHz, MCS3, 90pc duty cycle)	X	5.48	67.14	16.54	0.46	130.0	± 9.6 %
		Y	5.56	67.34	16.70		130.0	
		Z	5.32	67.06	16.42		130.0	
10603-AAB	IEEE 802.11n (HT Mixed, 40MHz, MCS4, 90pc duty cycle)	X	5.54	67.39	16.80	0.46	130.0	± 9.6 %
		Y	5.65	67.65	16.98		130.0	
		Z	5.37	67.31	16.69		130.0	
10604-AAB	IEEE 802.11n (HT Mixed, 40MHz, MCS5, 90pc duty cycle)	X	5.41	67.02	16.60	0.46	130.0	± 9.6 %
		Y	5.46	67.14	16.71		130.0	
		Z	5.27	66.97	16.49		130.0	
10605-AAB	IEEE 802.11n (HT Mixed, 40MHz, MCS6, 90pc duty cycle)	X	5.47	67.20	16.69	0.46	130.0	± 9.6 %
		Y	5.56	67.45	16.87		130.0	
		Z	5.29	67.05	16.52		130.0	
10606-AAB	IEEE 802.11n (HT Mixed, 40MHz, MCS7, 90pc duty cycle)	X	5.19	66.44	16.16	0.46	130.0	± 9.6 %
		Y	5.32	66.83	16.42		130.0	
		Z	5.08	66.47	16.09		130.0	

Certificate No: EX3-3847_Apr18

Page 35 of 39



EX3DV4- SN:3847

April 26, 2018

10607-AAB	IEEE 802.11ac WiFi (20MHz, MCS0, 90pc duty cycle)	X	4.49	65.54	15.80	0.46	130.0	± 9.6 %
		Y	4.62	65.94	16.12		130.0	
		Z	4.35	65.57	15.69		130.0	
10608-AAB	IEEE 802.11ac WiFi (20MHz, MCS1, 90pc duty cycle)	X	4.65	65.91	15.96	0.46	130.0	± 9.6 %
		Y	4.81	66.35	16.29		130.0	
		Z	4.48	65.89	15.84		130.0	
10609-AAB	IEEE 802.11ac WiFi (20MHz, MCS2, 90pc duty cycle)	X	4.54	65.74	15.79	0.46	130.0	± 9.6 %
		Y	4.70	66.20	16.13		130.0	
		Z	4.38	65.70	15.64		130.0	
10610-AAB	IEEE 802.11ac WiFi (20MHz, MCS3, 90pc duty cycle)	X	4.59	65.90	15.95	0.46	130.0	± 9.6 %
		Y	4.75	66.36	16.29		130.0	
		Z	4.43	65.88	15.82		130.0	
10611-AAB	IEEE 802.11ac WiFi (20MHz, MCS4, 90pc duty cycle)	X	4.51	65.70	15.80	0.46	130.0	± 9.6 %
		Y	4.66	66.16	16.14		130.0	
		Z	4.34	65.67	15.66		130.0	
10612-AAB	IEEE 802.11ac WiFi (20MHz, MCS5, 90pc duty cycle)	X	4.51	65.84	15.83	0.46	130.0	± 9.6 %
		Y	4.67	66.32	16.18		130.0	
		Z	4.33	65.77	15.68		130.0	
10613-AAB	IEEE 802.11ac WiFi (20MHz, MCS6, 90pc duty cycle)	X	4.51	65.70	15.71	0.46	130.0	± 9.6 %
		Y	4.68	66.20	16.07		130.0	
		Z	4.32	65.60	15.53		130.0	
10614-AAB	IEEE 802.11ac WiFi (20MHz, MCS7, 90pc duty cycle)	X	4.46	65.88	15.93	0.46	130.0	± 9.6 %
		Y	4.62	66.38	16.29		130.0	
		Z	4.29	65.83	15.79		130.0	
10615-AAB	IEEE 802.11ac WiFi (20MHz, MCS8, 90pc duty cycle)	X	4.51	65.55	15.58	0.46	130.0	± 9.6 %
		Y	4.67	66.00	15.92		130.0	
		Z	4.33	65.49	15.41		130.0	
10616-AAB	IEEE 802.11ac WiFi (40MHz, MCS0, 90pc duty cycle)	X	5.15	66.03	16.05	0.46	130.0	± 9.6 %
		Y	5.27	66.43	16.32		130.0	
		Z	5.00	65.97	15.95		130.0	
10617-AAB	IEEE 802.11ac WiFi (40MHz, MCS1, 90pc duty cycle)	X	5.22	66.24	16.14	0.46	130.0	± 9.6 %
		Y	5.34	66.59	16.37		130.0	
		Z	5.04	66.10	15.99		130.0	
10618-AAB	IEEE 802.11ac WiFi (40MHz, MCS2, 90pc duty cycle)	X	5.10	66.23	16.14	0.46	130.0	± 9.6 %
		Y	5.22	66.60	16.39		130.0	
		Z	4.95	66.15	16.02		130.0	
10619-AAB	IEEE 802.11ac WiFi (40MHz, MCS3, 90pc duty cycle)	X	5.11	66.02	15.97	0.46	130.0	± 9.6 %
		Y	5.24	66.42	16.23		130.0	
		Z	4.97	65.97	15.87		130.0	
10620-AAB	IEEE 802.11ac WiFi (40MHz, MCS4, 90pc duty cycle)	X	5.20	66.06	16.05	0.46	130.0	± 9.6 %
		Y	5.33	66.46	16.31		130.0	
		Z	5.04	65.98	15.93		130.0	
10621-AAB	IEEE 802.11ac WiFi (40MHz, MCS5, 90pc duty cycle)	X	5.21	66.21	16.24	0.46	130.0	± 9.6 %
		Y	5.33	66.58	16.48		130.0	
		Z	5.05	66.10	16.11		130.0	
10622-AAB	IEEE 802.11ac WiFi (40MHz, MCS6, 90pc duty cycle)	X	5.22	66.37	16.31	0.46	130.0	± 9.6 %
		Y	5.34	66.74	16.55		130.0	
		Z	5.04	66.18	16.15		130.0	

Certificate No: EX3-3847_Apr18

Page 36 of 39



EX3DV4- SN:3847

April 26, 2018

10623-AAB	IEEE 802.11ac WiFi (40MHz, MCS7, 90pc duty cycle)	X	5.10	65.88	15.93	0.46	130.0	± 9.6 %
		Y	5.22	66.28	16.20		130.0	
		Z	4.93	65.72	15.77		130.0	
10624-AAB	IEEE 802.11ac WiFi (40MHz, MCS8, 90pc duty cycle)	X	5.29	66.10	16.11	0.46	130.0	± 9.6 %
		Y	5.41	66.47	16.36		130.0	
		Z	5.13	66.01	15.99		130.0	
10625-AAB	IEEE 802.11ac WiFi (40MHz, MCS9, 90pc duty cycle)	X	5.57	66.83	16.54	0.46	130.0	± 9.6 %
		Y	5.77	67.42	16.88		130.0	
		Z	5.22	66.17	16.14		130.0	
10626-AAB	IEEE 802.11ac WiFi (80MHz, MCS0, 90pc duty cycle)	X	5.46	66.12	16.04	0.46	130.0	± 9.6 %
		Y	5.57	66.49	16.27		130.0	
		Z	5.33	66.02	15.93		130.0	
10627-AAB	IEEE 802.11ac WiFi (80MHz, MCS1, 90pc duty cycle)	X	5.71	66.74	16.32	0.46	130.0	± 9.6 %
		Y	5.80	67.03	16.50		130.0	
		Z	5.57	66.65	16.21		130.0	
10628-AAB	IEEE 802.11ac WiFi (80MHz, MCS2, 90pc duty cycle)	X	5.48	66.16	15.96	0.46	130.0	± 9.6 %
		Y	5.60	66.59	16.22		130.0	
		Z	5.33	66.00	15.81		130.0	
10629-AAB	IEEE 802.11ac WiFi (80MHz, MCS3, 90pc duty cycle)	X	5.56	66.26	16.00	0.46	130.0	± 9.6 %
		Y	5.68	66.64	16.24		130.0	
		Z	5.43	66.19	15.91		130.0	
10630-AAB	IEEE 802.11ac WiFi (80MHz, MCS4, 90pc duty cycle)	X	5.96	67.65	16.70	0.46	130.0	± 9.6 %
		Y	6.09	68.07	16.95		130.0	
		Z	5.68	67.14	16.38		130.0	
10631-AAB	IEEE 802.11ac WiFi (80MHz, MCS5, 90pc duty cycle)	X	5.85	67.41	16.77	0.46	130.0	± 9.6 %
		Y	6.00	67.90	17.05		130.0	
		Z	5.64	67.15	16.59		130.0	
10632-AAB	IEEE 802.11ac WiFi (80MHz, MCS6, 90pc duty cycle)	X	5.68	66.81	16.49	0.46	130.0	± 9.6 %
		Y	5.77	67.09	16.67		130.0	
		Z	5.57	66.83	16.45		130.0	
10633-AAB	IEEE 802.11ac WiFi (80MHz, MCS7, 90pc duty cycle)	X	5.54	66.34	16.08	0.46	130.0	± 9.6 %
		Y	5.66	66.75	16.33		130.0	
		Z	5.36	66.11	15.91		130.0	
10634-AAB	IEEE 802.11ac WiFi (80MHz, MCS8, 90pc duty cycle)	X	5.52	66.35	16.14	0.46	130.0	± 9.6 %
		Y	5.65	66.78	16.40		130.0	
		Z	5.38	66.27	16.04		130.0	
10635-AAB	IEEE 802.11ac WiFi (80MHz, MCS9, 90pc duty cycle)	X	5.40	65.89	15.55	0.46	130.0	± 9.6 %
		Y	5.53	66.13	15.82		130.0	
		Z	5.24	65.52	15.38		130.0	
10636-AAC	IEEE 802.11ac WiFi (160MHz, MCS0, 90pc duty cycle)	X	5.89	66.51	16.15	0.46	130.0	± 9.6 %
		Y	5.98	66.86	16.36		130.0	
		Z	5.77	66.40	16.04		130.0	
10637-AAC	IEEE 802.11ac WiFi (160MHz, MCS1, 90pc duty cycle)	X	6.05	66.90	16.33	0.46	130.0	± 9.6 %
		Y	6.13	67.23	16.53		130.0	
		Z	5.89	66.72	16.18		130.0	
10638-AAC	IEEE 802.11ac WiFi (160MHz, MCS2, 90pc duty cycle)	X	6.04	66.86	16.29	0.46	130.0	± 9.6 %
		Y	6.13	67.21	16.49		130.0	
		Z	5.91	66.76	16.18		130.0	

Certificate No: EX3-3847_Apr18

Page 37 of 39



EX3DV4- SN:3847

April 26, 2018

10639-AAC	IEEE 802.11ac WiFi (160MHz, MCS3, 90pc duty cycle)	X	6.01	66.78	16.29	0.46	130.0	± 9.6 %
		Y	6.11	67.16	16.52		130.0	
		Z	5.87	66.64	16.16		130.0	
10640-AAC	IEEE 802.11ac WiFi (160MHz, MCS4, 90pc duty cycle)	X	6.01	66.78	16.23	0.46	130.0	± 9.6 %
		Y	6.12	67.18	16.47		130.0	
		Z	5.83	66.54	16.05		130.0	
10641-AAC	IEEE 802.11ac WiFi (160MHz, MCS5, 90pc duty cycle)	X	6.08	66.77	16.25	0.46	130.0	± 9.6 %
		Y	6.16	67.08	16.43		130.0	
		Z	5.93	66.63	16.12		130.0	
10642-AAC	IEEE 802.11ac WiFi (160MHz, MCS6, 90pc duty cycle)	X	6.10	66.96	16.51	0.46	130.0	± 9.6 %
		Y	6.20	67.33	16.72		130.0	
		Z	5.95	66.83	16.39		130.0	
10643-AAC	IEEE 802.11ac WiFi (160MHz, MCS7, 90pc duty cycle)	X	5.95	66.67	16.26	0.46	130.0	± 9.6 %
		Y	6.04	67.02	16.47		130.0	
		Z	5.80	66.51	16.11		130.0	
10644-AAC	IEEE 802.11ac WiFi (160MHz, MCS8, 90pc duty cycle)	X	6.08	67.02	16.46	0.46	130.0	± 9.6 %
		Y	6.20	67.51	16.74		130.0	
		Z	5.86	66.89	16.23		130.0	
10645-AAC	IEEE 802.11ac WiFi (160MHz, MCS9, 90pc duty cycle)	X	6.22	67.15	16.49	0.46	130.0	± 9.6 %
		Y	6.53	68.09	16.99		130.0	
		Z	6.01	66.82	16.26		130.0	
10646-AAD	LTE-TDD (SC-FDMA, 1 RB, 5 MHz, QPSK, UL Subframe=2,7)	X	12.46	102.82	35.86	9.30	60.0	± 9.6 %
		Y	25.38	119.99	41.31		60.0	
		Z	6.60	88.90	30.62		60.0	
10647-AAC	LTE-TDD (SC-FDMA, 1 RB, 20 MHz, QPSK, UL Subframe=2,7)	X	10.85	100.16	35.12	9.30	60.0	± 9.6 %
		Y	20.81	115.94	40.28		60.0	
		Z	5.89	86.80	29.96		60.0	
10648-AAA	CDMA2000 (1x Advanced)	X	0.51	60.75	7.97	0.00	150.0	± 9.6 %
		Y	0.66	63.18	10.50		150.0	
		Z	0.41	60.00	6.58		150.0	
10652-AAB	LTE-TDD (OFDMA, 5 MHz, E-TM 3.1, Clipping 44%)	X	3.30	65.73	15.83	2.23	80.0	± 9.6 %
		Y	3.62	67.09	16.80		80.0	
		Z	3.01	65.04	15.12		80.0	
10653-AAB	LTE-TDD (OFDMA, 10 MHz, E-TM 3.1, Clipping 44%)	X	3.88	65.34	16.17	2.23	80.0	± 9.6 %
		Y	4.12	66.32	16.85		80.0	
		Z	3.63	64.83	15.69		80.0	
10654-AAB	LTE-TDD (OFDMA, 15 MHz, E-TM 3.1, Clipping 44%)	X	3.88	65.02	16.21	2.23	80.0	± 9.6 %
		Y	4.09	65.94	16.83		80.0	
		Z	3.66	64.54	15.77		80.0	
10655-AAB	LTE-TDD (OFDMA, 20 MHz, E-TM 3.1, Clipping 44%)	X	3.95	65.00	16.26	2.23	80.0	± 9.6 %
		Y	4.15	65.93	16.86		80.0	
		Z	3.74	64.49	15.83		80.0	
10658-AAA	Pulse Waveform (200Hz, 10%)	X	100.00	110.04	25.52	10.00	50.0	± 9.6 %
		Y	100.00	112.50	26.65		50.0	
		Z	4.52	71.85	13.49		50.0	
10659-AAA	Pulse Waveform (200Hz, 20%)	X	100.00	108.16	23.56	6.99	60.0	± 9.6 %
		Y	100.00	112.26	25.56		60.0	
		Z	3.99	73.17	12.80		60.0	

Certificate No: EX3-3847_Apr18

Page 38 of 39



EX3DV4- SN:3847

April 26, 2018

10660-AAA	Pulse Waveform (200Hz, 40%)	X	100.00	105.70	21.19	3.98	80.0	± 9.6 %
		Y	100.00	114.35	25.21		80.0	
		Z	1.97	89.76	10.09		80.0	
10661-AAA	Pulse Waveform (200Hz, 60%)	X	100.00	100.43	17.89	2.22	100.0	± 9.6 %
		Y	100.00	117.83	25.42		100.0	
		Z	0.29	80.00	4.69		100.0	
10662-AAA	Pulse Waveform (200Hz, 80%)	X	0.17	80.00	3.90	0.97	120.0	± 9.6 %
		Y	100.00	119.81	24.45		120.0	
		Z	12.34	60.39	1.42		120.0	

^f Uncertainty is determined using the max. deviation from linear response applying rectangular distribution and is expressed for the square of the field value.



MR-008_18-124



In Collaboration with
s p e a g
CALIBRATION LABORATORY



中国认可
国际互认
校准
CALIBRATION
CNAS L0570

Add: No.51 Xueyuan Road, Haidian District, Beijing, 100191, China
Tel: +86-10-62304633-2512 Fax: +86-10-62304633-2504
E-mail: cttl@chinattl.com [Http://www.chinattl.cn](http://www.chinattl.cn)

Client : **ATL**

Certificate No: **Z18-60043**

CALIBRATION CERTIFICATE

Object: **DAE4 - SN: 541**

Calibration Procedure(s): **FF-Z11-002-01**
Calibration Procedure for the Data Acquisition Electronics (DAEx)

Calibration date: **March 22, 2018**

This calibration Certificate documents the traceability to national standards, which realize the physical units of measurements(SI). The measurements and the uncertainties with confidence probability are given on the following pages and are part of the certificate.

All calibrations have been conducted in the closed laboratory facility: environment temperature(22±3)°C and humidity<70%.

Calibration Equipment used (M&TE critical for calibration)

Primary Standards	ID #	Cal Date(Calibrated by, Certificate No.)	Scheduled Calibration
Process Calibrator 753	1971018	27-Jun-17 (CTTL, No.J17X05859)	June-18

	Name	Function	Signature
Calibrated by:	Yu Zongying	SAR Test Engineer	
Reviewed by:	Lin Hao	SAR Test Engineer	
Approved by:	Qi Dianyuan	SAR Project Leader	

Issued: March 23, 2018

This calibration certificate shall not be reproduced except in full without written approval of the laboratory.

Certificate No: Z18-60043

Page 1 of 3



Add: No.51 Xueyuan Road, Haidian District, Beijing, 100191, China
Tel: +86-10-62304633-2512 Fax: +86-10-62304633-2504
E-mail: cttl@chinattl.com Http://www.chinattl.cn

Glossary:

DAE data acquisition electronics
Connector angle information used in DASY system to align probe sensor X to the robot coordinate system.

Methods Applied and Interpretation of Parameters:

- *DC Voltage Measurement:* Calibration Factor assessed for use in DASY system by comparison with a calibrated instrument traceable to national standards. The figure given corresponds to the full scale range of the voltmeter in the respective range.
- *Connector angle:* The angle of the connector is assessed measuring the angle mechanically by a tool inserted. Uncertainty is not required.
- The report provide only calibration results for DAE, it does not contain other performance test results.



Add: No.51 Xueyuan Road, Haidian District, Beijing, 100191, China
 Tel: +86-10-62304633-2512 Fax: +86-10-62304633-2504
 E-mail: cttl@chinattl.com Http://www.chinattl.cn

DC Voltage Measurement

A/D - Converter Resolution nominal
 High Range: 1LSB = 6.1μV , full range = -100...+300 mV
 Low Range: 1LSB = 61nV , full range = -1.....+3mV
 DASY measurement parameters: Auto Zero Time: 3 sec; Measuring time: 3 sec

Calibration Factors	X	Y	Z
High Range	404.524 ± 0.15% (k=2)	404.384 ± 0.15% (k=2)	404.149 ± 0.15% (k=2)
Low Range	3.96849 ± 0.7% (k=2)	3.93466 ± 0.7% (k=2)	3.97493 ± 0.7% (k=2)

Connector Angle

Connector Angle to be used in DASY system	289° ± 1°
---	-----------