

Test Report

Product: Charger Night light

Trade Mark: Merkury, Leadingplus

Model Number: WA-DL024-199

FCC ID: 2APTY-DL02425

Prepared for

LeadingPlus Electronic Co.,Ltd
Room 102, Building A2, Demei Industrial Center, Donghuan 2nd Road,
Longhua Street, Shenzhen, Guangdong, China

Prepared by

Shenzhen HongBiao Certification& Testing Co., Ltd
Room 102, 201, Building 2, Yuanwanggu RFID Industrial Park, Tongguan
Road, Tianliao Community, Yutang Street, Guangming District, Shenzhen,
China
Tel.: +86-755-2998 9321 Fax.: +86-755-2998 5110
Website: <http://www.sz-hongbiao.com>

Table of Contents

1	GENERAL DESCRIPTION	5
1.1	DESCRIPTION OF EUT	5
1.2	TEST MODE.....	5
1.3	TEST SETUP	5
1.4	POWER SETTING CONFIGURATION PARAMETERS	6
1.5	ANCILLARY EQUIPMENT	6
2	SUMMARY OF TEST RESULT	7
3	TEST FACILITIES AND ACCREDITATIONS	8
3.1	TEST LABORATORY	8
3.2	ENVIRONMENTAL CONDITIONS	8
3.3	MEASUREMENT UNCERTAINTY	8
3.4	TEST SOFTWARE	8
4	LIST OF TEST EQUIPMENT	10
5	TEST ITEM AND RESULTS	12
5.1	ANTENNA REQUIREMENT	12
5.2	CONDUCTED EMISSION	13
5.3	RADIATED EMISSION	17
5.4	OCCUPIED BANDWIDTH	22
6	PHOTOGRAPHS OF THE TEST SETUP.....	23
7	PHOTOGRAPHS OF THE EUT	25

1 General Description

1.1 Description of EUT

Product name:	Charger Night light
Model name:	WA-DL024-199
Series Model:	WA-DL025-199
Different of series model:	All the models are the same circuit and module, except the appearance.
Operation frequency:	115kHz-250kHz
Operational mode:	Wireless charging
Modulation type:	ASK
Antenna type:	Coil Antenna
Hardware version:	WL199-V1.1
Software version:	WL199-V1.1
Battery:	N/A
Power supply:	Input: DC 5V/3A, DC 9V/2A Wireless Output: 5W/7.5W/10W/15W Light Output: 1.2W
Adapter information:	N/A

1.2 Test Mode

Pretest Test Mode	Description of Mode
1	AC/DC adapter+Wireless Output: 5W
2	AC/DC adapter+Wireless Output: 7.5W
3	AC/DC adapter+Wireless Output: 10W
4	AC/DC adapter+Wireless Output: 15W

Test Item	Final Test Mode
Conducted Emissions	3
Radiated Emissions	4
20dB bandwidth	4

1.3 Test Setup

See photographs of the test setup in the report for the actual setup and connections between EUT and support equipment.

1.4 Power setting configuration parameters

Test Software Version	N/A		
Frequency	115kHz-250kHz		
Parameters	Default		
RF cable			
Description	Connector	Length	Supplied by
Antenna Cable	SMA	10cm	Applicant

Note: Disclaimer: the loss of RF cable is too small and can be ignored.

1.5 Ancillary Equipment

Equipment	Model	S/N	Manufacturer
Adapter	CD289	/	Ugreen Group Limited
Load	YBZ3.1	/	Shenzhen Leaper Technology Co., Ltd.

2 Summary of Test Result

Test procedures according to the technical standards:

FCC Part 15C				
No.	Standard Section	Test Item	Result	Remark
1	FCC Part 15.203	Antenna Requirement	Pass	
2	FCC Part 15.207	Conducted Emission	Pass	
3	FCC Part 15.209	Radiated Emission	Pass	
4	FCC Part 15.215	20dB Bandwidth	Pass	

Note:

1. "N/A" means the test case does not apply to the test object.

3 Test Facilities and Accreditations

3.1 Test Laboratory

Test Site	Shenzhen HongBiao Certification& Testing Co., Ltd
Test Site Location	Room 102, 201, Building 2, Yuanwanggu RFID Industrial Park, Tongguan Road, Tianliao Community, Yutang Street, Guangming District, Shenzhen, China
Telephone:	(86-755) 2998 9321
Fax:	(86-755) 2998 5110
FCC Registration No.:	CN1341
A2LA Certificate No.:	6765.01

3.2 Environmental Conditions

During the measurement the environmental conditions were within the listed ranges:

Temperature:	15°C~35°C
Relative Humidity:	20%~75%
Air Pressure:	98kPa~101kPa

3.3 Measurement Uncertainty

The reported uncertainty of measurement $y \pm U$, where expanded uncertainty U is based on a standard uncertainty multiplied by a coverage factor of $k=2$, providing a level of confidence of approximately 95 %.

The data and results quoted in this document are true and accurate values, and uncertainties are not involved in the calculations.

In addition, components and mass production processes that are similar to testing equipment may introduce additional deviations, and the manufacturer is solely responsible for the continued compliance of the equipment.

Measurement Frequency Range	U, (dB)	Note
RF frequency	2×10^{-5}	
RF power, conducted	± 0.57 dB	
Conducted emission(150kHz~30MHz)	± 2.5 dB	
Radiated emission(9kHz-30MHz)	± 2.5 dB	
Radiated emission(30MHz~1GHz)	± 4.2 dB	
Occupied Bandwidth	$\pm 3\%$	
Temperature	± 1 degree	
Humidity	± 5 %	

3.4 Test Software

Software name	Manufacturer	Model	Version
Conducted Emission test Software	Farad	EZ-EMC	EMC-CON 3A1.1+
Radiated Emission test Software	Farad	EZ-EMC	FA-03A2
RF Test System	MWRF	MTS 8310	2.0.0.0

4 List of Test Equipment

Radiation emission							
Item	Equipment No.	Equipment name	Manufacturer	Model	Serial No.	Calibration date	Due date
1	HB-E001	Horn Antenna	Schwarzbeck	BBHA 9120D	02592	2024-05-18	2026-05-17
2	HB-E002	Biconical log-periodic composite antenna	Schwarzbeck	VULB 9168	01340	2024-05-18	2026-05-17
3	HB-E003	SHF-EHF Horn	Schwarzbeck	BBHA 91270	01193	2024-05-18	2026-05-17
4	HB-E005	Preamplifier	Noyetec	LAN-0118	NYCM1420102	2025-05-07	2026-05-06
5	HB-E006	Preamplifier	Noyetec	LAN-1840	NYCM1420103	2025-05-07	2026-05-06
6	HB-E007	EMI TEST RECEIVER	R&S	ESR7	102520	2025-05-07	2026-05-06
7	HB-E009	POSITINAL COTROLLE R	Noyetec	N/A	N/A	/	/
8	HB-E013	RF switch	Noyetec	NY-RF4	NY0CM1420204	/	/
9	HB-E066	Illuminance Tester	TASI	TA8121	N/A	2025-05-13	2026-05-12
10	HB-E075	Active loop antenna	Schwarzbeck	FMZB 1519B	1519B-245	2024-05-18	2026-05-17
11	HB-E076	Preamplifier	Hewlett Packard	8447D	1937A02278	2025-05-07	2026-05-06
Conduction emission							
Item	Equipment No.	Equipment name	Manufacturer	Model	Serial No.	Calibration date	Due date
1	HB-E014	4 Path V-LISN	Schwarzbeck	NNLK 8121	00770	2025-05-07	2026-05-06
2	HB-E015	Pulse Limiter	Schwarzbeck	VTSD 9561-F	00949	2025-05-07	2026-05-06
3	HB-E016	ZN23201	Noyetec	ZN23201	N/A	2025-05-10	2026-05-09
4	HB-E059	Attenuator	Xianghua	TS2-6-1	220215166	2025-05-10	2026-05-09
5	HB-E069	EMI TEST RECEIVER	R&S	ESCI	N/A	2025-05-07	2026-05-06
RF							
Item	Equipment No.	Equipment name	Manufacturer	Model	Serial No.	Calibration date	Due date
1	HB-E041	MXG Anaioq Signal Generator	Agilent	N5181A	MY47070421	2025-05-07	2026-05-06
2	HB-E042	WIDEBAND RADIO COMMUNICATION TESTER	R&S	CMW500	132108	2025-05-08	2026-05-07

3	HB-E043	MXG Anaioig Signal Generator	Agilent	N5182A	US46240335	2025-05-08	2026-05-07
4	HB-E044	Signal& spectrum Analyzer	R&S	FSV3044	101264	2025-05-07	2026-05-06
5	HB-E045	RF Control Box	Noyetec	NY100-R FCB	N/A	2025-05-08	2026-05-07
6	HB-E058	Thermometer Clock Humidity Monitor	N/A	HTC-1S	N/A	2025-05-09	2026-05-08

Note: the calibration interval of the above test instruments is 12&24 months and the calibrations are traceable to international system unit (SI).

5 Test Item And Results

5.1 Antenna Requirement

5.1.1 Standard Requirement

15.203 requirement: For intentional device, according to 15.203: an intentional radiator shall be designed to ensure that no antenna other than that furnished by the responsible party shall be used with the device

5.1.2 Test Result

The EUT antenna is Coil Antenna. It comply with the standard requirement. In case of replacement of broken antenna the same antenna type must be used.

5.2 Conducted Emission

5.2.1 Limits

Limits – Class A		
Frequency (MHz)	Limit (dB μ V)	
	Quasi-Peak	Average
0.15 to 0.5	79	66
0.5 to 30	73	60
Limits – Class B		
Frequency (MHz)	Limit (dB μ V)	
	Quasi-Peak	Average
0.15 to 0.5	66 to 56*	56 to 46*
0.5 to 5	56	46
5 to 30	60	50
Note: 1. the tighter limit applies at the band edges. 2. the limit of " * " marked band means the limitation decreases linearly with the logarithm of the frequency in the range.		

5.2.2 Test Procedures

- a) The EUT was placed 0.8 meters from the horizontal ground plane with EUT being connected to the power mains through a line impedance stabilization network (LISN). All other support equipment powered from additional LISN(s). The LISN provide 50 Ohm/ 50uH of coupling impedance for the measuring instrument.
- b) Interconnecting cables that hang closer than 40 cm to the ground plane shall be folded back and forth in the center forming a bundle 30 to 40 cm long.
- c) I/O cables that are not connected to a peripheral shall be bundled in the center. The end of the cable may be terminated, if required, using the correct terminating impedance. The overall length shall not exceed 1 m.
- d) LISN is at least 80 cm from nearest part of EUT chassis.
- e) For the actual test configuration, please refer to the related Item – photographs of the test setup.

5.2.3 Test setup

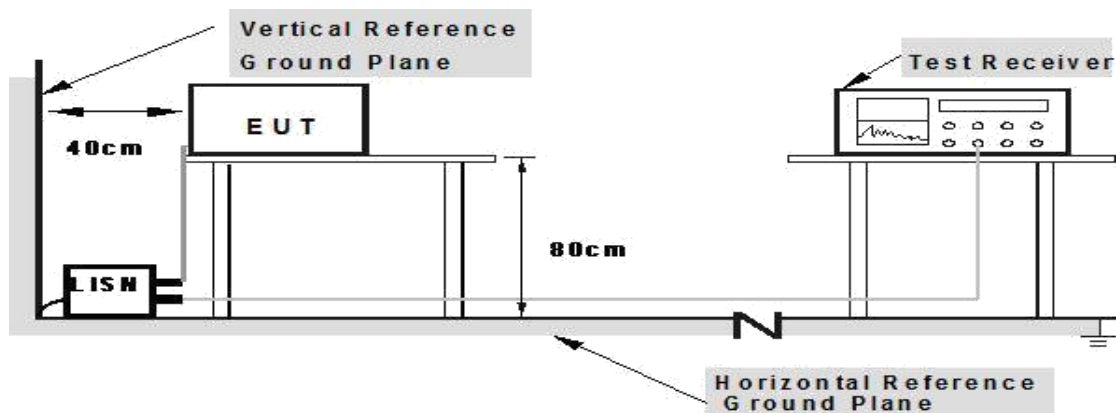

5.2.4 Test Result

EUT:	Charger Night light	Model Name:	WA-DL024-199
Test Mode:	Mode 3	Phase:	L
Test Voltage:	DC 9V from adapter AC 120V/60Hz		

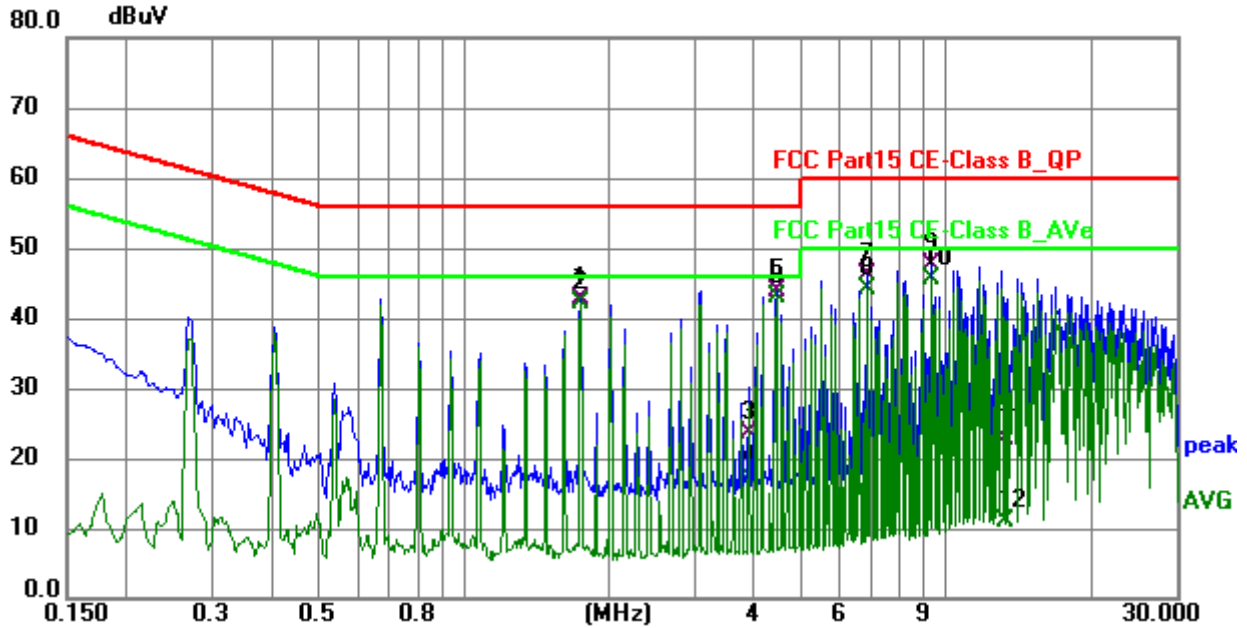

No.	Frequency (MHz)	Reading (dBuV)	Factor (dB)	Level (dBuV)	Limit (dBuV)	Margin (dB)	Detector
1	1.748	32.55	10.29	42.84	56.00	-13.16	QP
2	1.748	31.87	10.29	42.16	46.00	-3.84	AVG
3	3.903	12.68	10.90	23.58	56.00	-32.42	QP
4	3.903	6.45	10.90	17.35	46.00	-28.65	AVG
5	4.434	32.72	11.13	43.85	56.00	-12.15	QP
6 *	4.434	31.75	11.13	42.88	46.00	-3.12	AVG
7	6.855	33.89	12.24	46.13	60.00	-13.87	QP
8	6.855	31.90	12.24	44.14	50.00	-5.86	AVG
9	9.271	34.29	13.26	47.55	60.00	-12.45	QP
10	9.271	32.45	13.26	45.71	50.00	-4.29	AVG
11	13.304	8.69	13.92	22.61	60.00	-37.39	QP
12	13.304	-2.86	13.92	11.06	50.00	-38.94	AVG

EUT:	Charger Night light	Model Name:	WA-DL024-199
Test Mode:	Mode 3	Phase:	N
Test Voltage:	DC 9V from adapter AC 120V/60Hz		

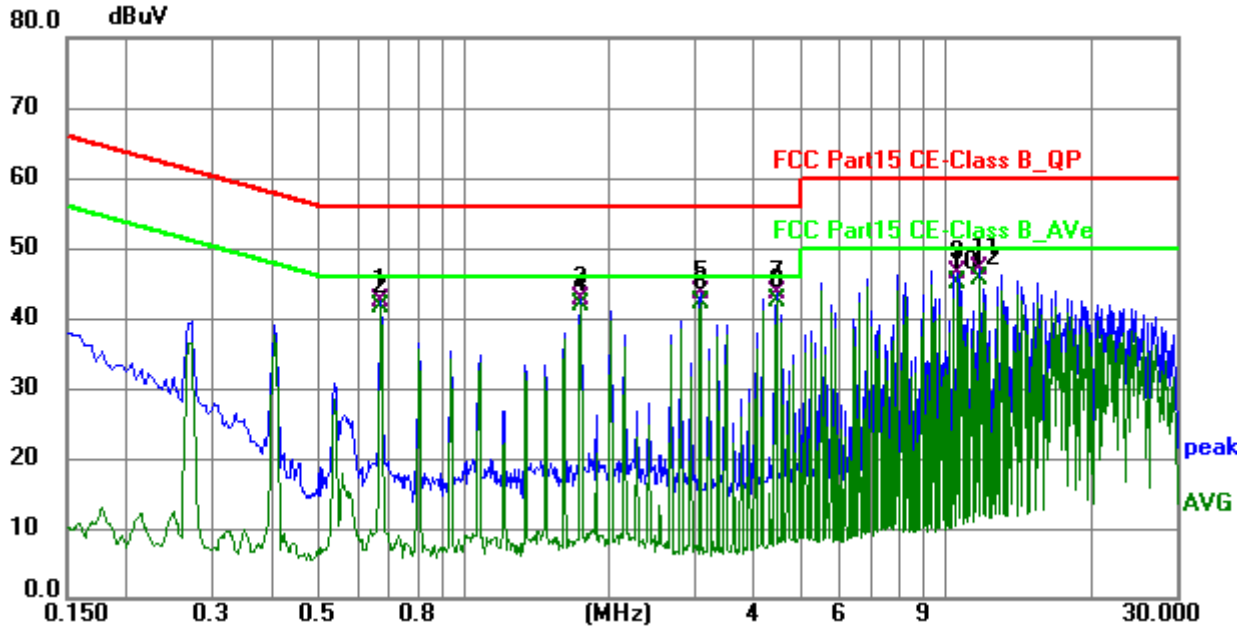

No.	Frequency (MHz)	Reading (dBuV)	Factor (dB)	Level (dBuV)	Limit (dBuV)	Margin (dB)	Detector
1	0.672	32.23	10.12	42.35	56.00	-13.65	QP
2	0.672	31.43	10.12	41.55	46.00	-4.45	AVG
3	1.748	32.36	10.29	42.65	56.00	-13.35	QP
4	1.748	31.45	10.29	41.74	46.00	-4.26	AVG
5	3.093	32.98	10.67	43.65	56.00	-12.35	QP
6	3.093	31.39	10.67	42.06	46.00	-3.94	AVG
7	4.434	32.50	11.13	43.63	56.00	-12.37	QP
8 *	4.434	31.33	11.13	42.46	46.00	-3.54	AVG
9	10.617	32.79	13.69	46.48	60.00	-13.52	QP
10	10.617	31.26	13.69	44.95	50.00	-5.05	AVG
11	11.693	33.29	13.79	47.08	60.00	-12.92	QP
12	11.693	31.66	13.79	45.45	50.00	-4.55	AVG

5.3 Radiated Emission

5.3.1 Limits

Frequencies (MHz)	Field Strength (micorvolts/meter)	Measurement Distance (meters)
0.009~0.490	2400/F(KHz)	300
0.490~1.705	24000/F(KHz)	30
1.705~30.0	30	30
30~88	100	3
88~216	150	3
216~960	200	3
Above 960	500	3

Receiver Parameter	Setting
Attenuation	Auto
Start ~ Stop Frequency	9kHz~150kHz / RB 200Hz for QP
Start ~ Stop Frequency	150kHz~30MHz / RB 9kHz for QP
Start ~ Stop Frequency	30MHz~1000MHz / RB 120kHz for QP

5.3.2 Test Procedures

- a) The radiated emission tests were performed in the 3 meters.
- b) The EUT was placed on the top of a rotating table 0.8 meters above the ground. The table was rotated 360 degrees to determine the position of the highest radiation.
- c) The height of the test antenna shall vary between 1m to 4m. Both horizontal and vertical polarizations of the antenna are set to make the measurement.
- d) If the peak mode measured value compliance with and lower than quasi peak mode limit, the EUT shall be deemed to meet QP limits and then no additional QP mode measurement performed.
- e) If the peak mode measured value compliance with and lower than average mode limit, the EUT shall be deemed to meet average limits and then no additional average mode measurement performed.
- f) For the actual test configuration, please refer to the related item – EUT test photos.

5.3.3 Test Setup

Radiated Emission Test-Up Frequency Below 30MHz

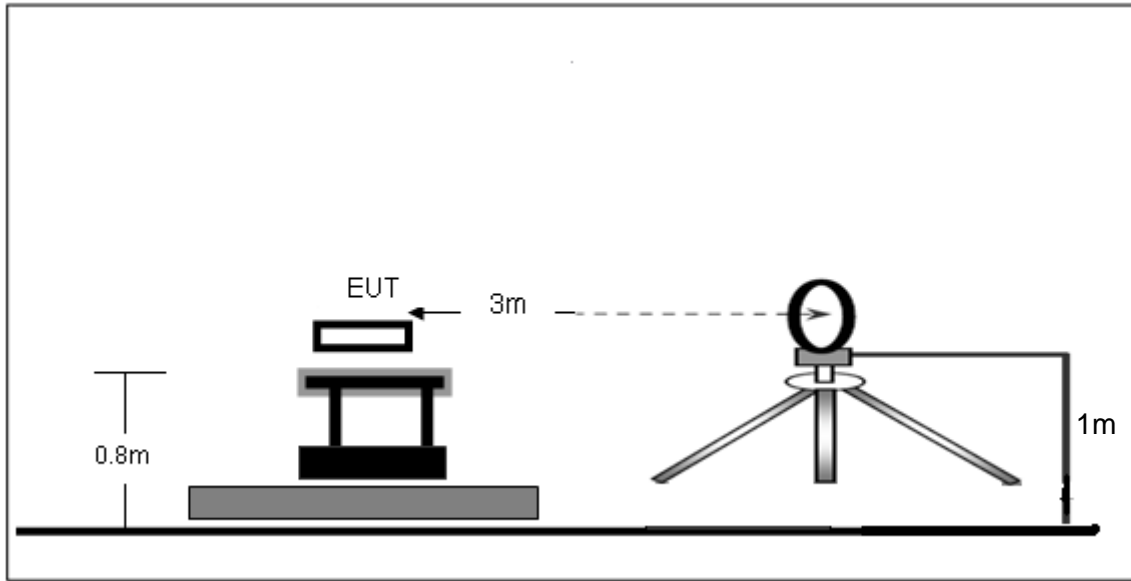

Radiated Emission Test-Up Frequency 30MHz~1GHz

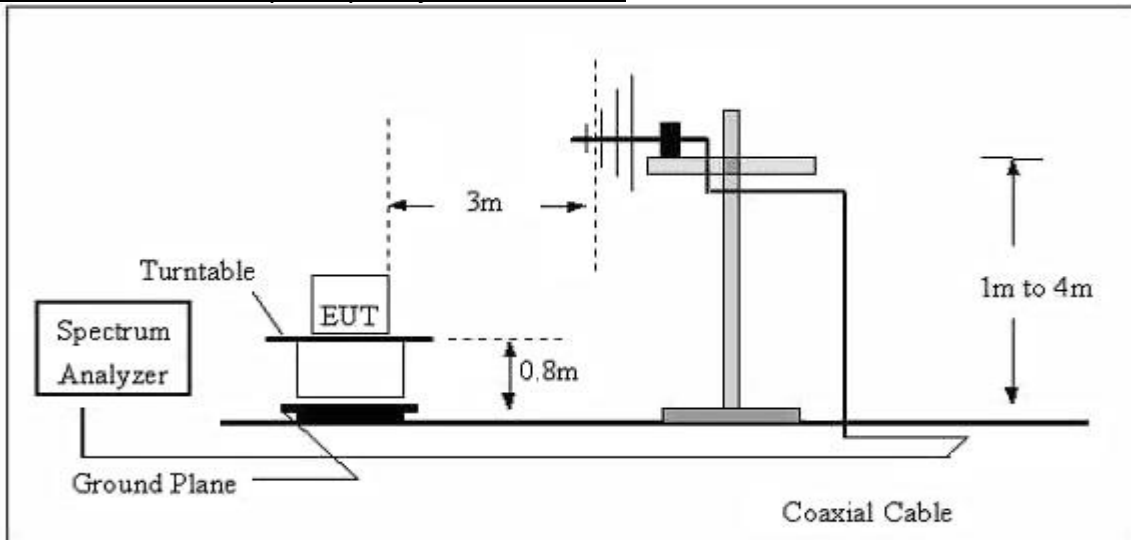

5.3.4 Test Result

Frequency range (9kHz – 30MHz)

EUT:	Charger Night light	Model Name:	WA-DL024-199
Test Mode:	Mode 4	Phase:	Coaxial
Test Voltage:	DC 9V from adapter AC 120V/60Hz		

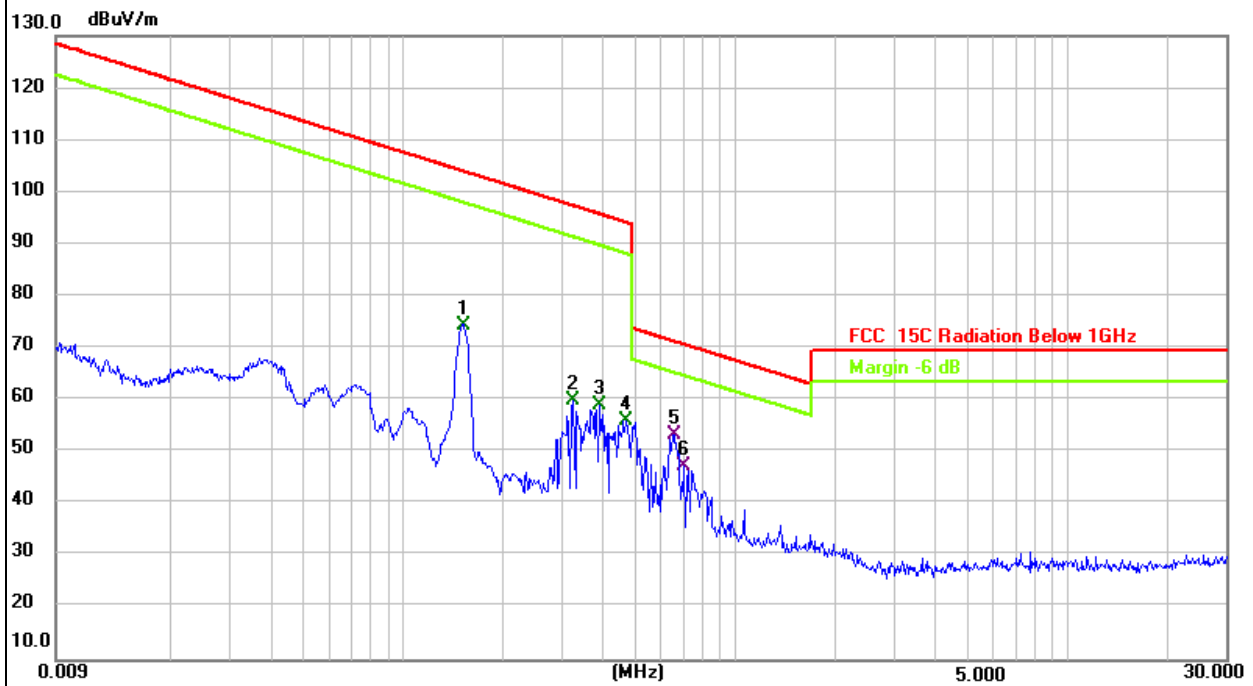

No.	Frequency (MHz)	Reading (dBuV)	Factor (dB/m)	Level (dBuV/m)	Limit (dBuV/m)	Margin (dB)	Detector
1	0.1514	54.36	20.14	74.50	104.02	-29.52	AVG
2	0.3246	39.93	20.09	60.02	97.38	-37.36	AVG
3	0.3912	38.87	20.06	58.93	95.76	-36.83	AVG
4	0.4676	36.10	20.05	56.15	94.21	-38.06	AVG
5 *	0.6521	33.15	20.11	53.26	71.32	-18.06	QP
6	0.7015	25.72	21.52	47.24	70.69	-23.45	QP

Frequency range (30MHz – 1GHz)

EUT:	Charger Night light	Model Name:	WA-DL024-199
Test Mode:	Mode 4	Phase:	Vertical
Test Voltage:	DC 9V from adapter AC 120V/60Hz		

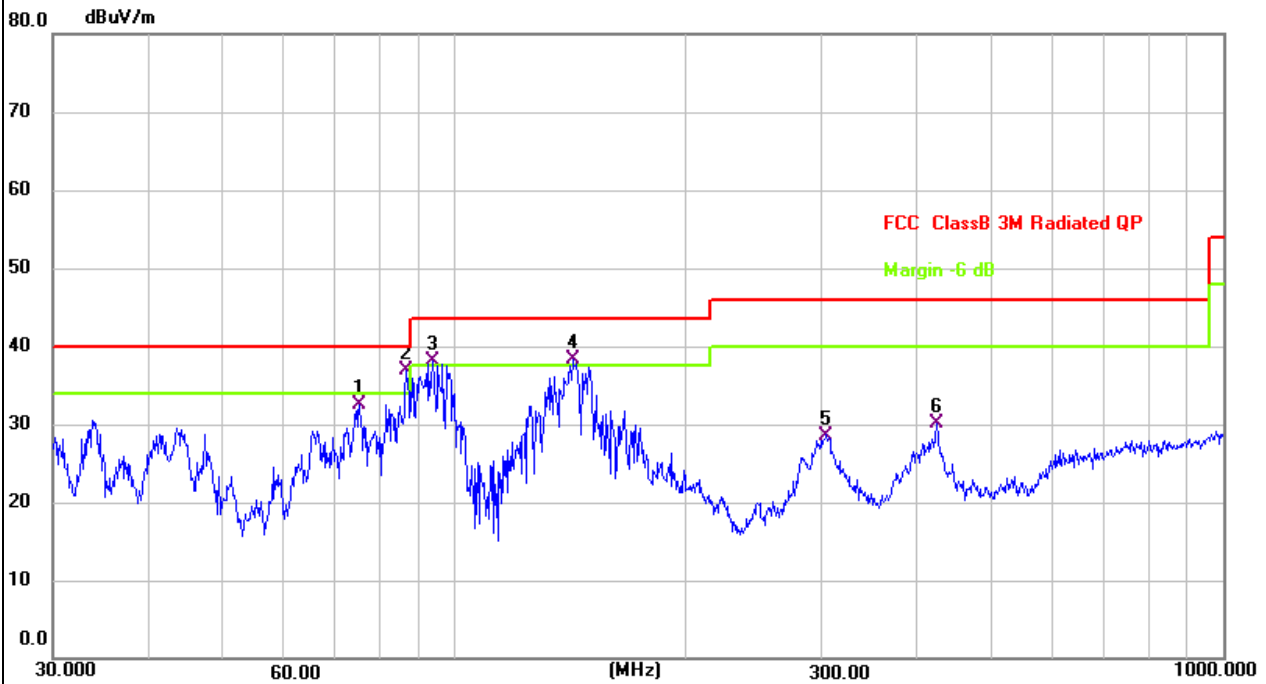

No.	Frequency (MHz)	Reading (dBuV)	Factor (dB/m)	Level (dBuV/m)	Limit (dBuV/m)	Margin (dB)	Detector
1	75.1822	49.30	-16.81	32.49	40.00	-7.51	QP
2 *	86.5029	55.21	-18.26	36.95	40.00	-3.05	QP
3 !	93.4402	56.00	-17.93	38.07	43.50	-5.43	QP
4 !	142.3243	52.21	-13.92	38.29	43.50	-5.21	QP
5	304.6099	40.90	-12.30	28.60	46.00	-17.40	QP
6	423.5403	38.81	-8.68	30.13	46.00	-15.87	QP

EUT:	Charger Night light	Model Name:	WA-DL024-199
Test Mode:	Mode 4	Phase:	Horizontal
Test Voltage:	DC 9V from adapter AC 120V/60Hz		

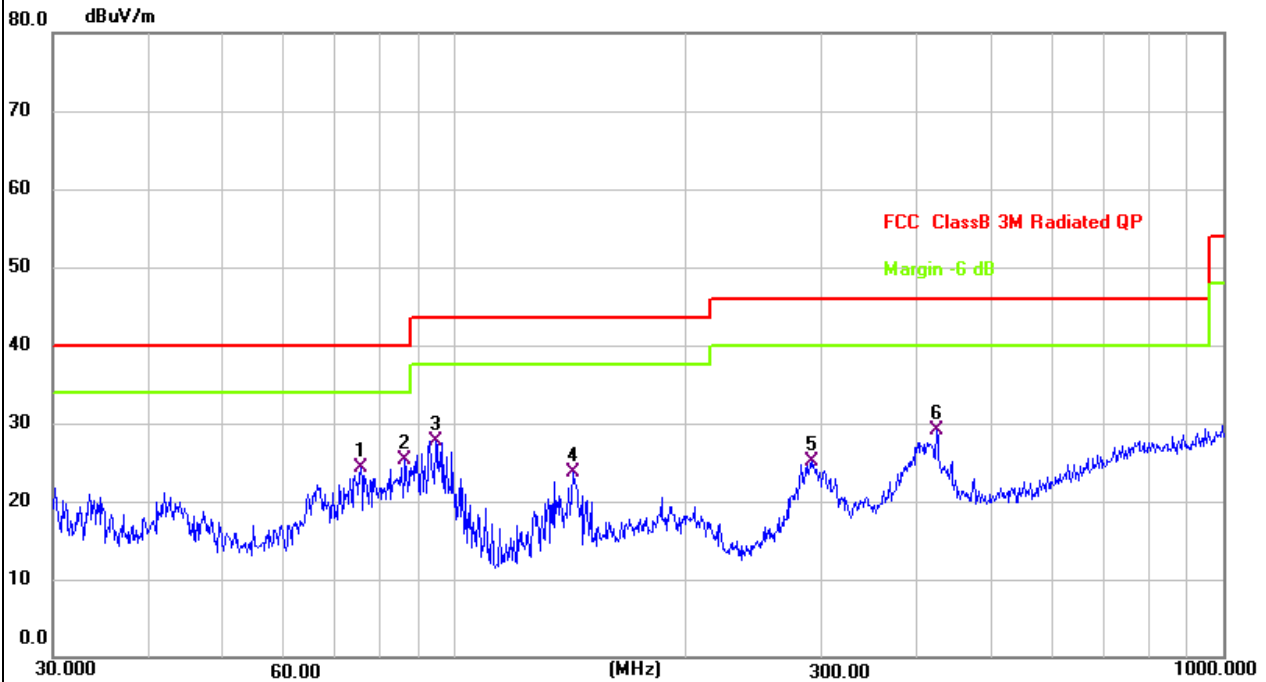

No.	Frequency (MHz)	Reading (dBuV)	Factor (dB/m)	Level (dBuV/m)	Limit (dBuV/m)	Margin (dB)	Detector
1	75.4464	41.23	-16.86	24.37	40.00	-15.63	QP
2 *	86.2001	43.45	-18.23	25.22	40.00	-14.78	QP
3	94.4284	45.57	-17.82	27.75	43.50	-15.75	QP
4	142.8243	37.47	-13.82	23.65	43.50	-19.85	QP
5	291.0360	38.00	-12.80	25.20	46.00	-20.80	QP
6	423.5403	37.83	-8.68	29.15	46.00	-16.85	QP

5.4 Occupied Bandwidth

5.4.1 Test method

Use the following spectrum analyzer settings:

Span = approximately 2 to 3 times the 20 dB bandwidth, centered on a hopping channel

RBW $\geq 1\%$ to 5% of the OBW

VBW $\geq 3 \times$ RBW

Sweep = auto

Detector function = peak

Trace = max hold

The EUT should be transmitting at its maximum data rate. Allow the trace to stabilize. Use the marker-to-peak function to set the marker to the peak of the emission. Use the marker-delta function to measure 20 dB down one side of the emission. Reset the marker-delta function, and move the marker to the other side of the emission, until it is (as close as possible to) even with the reference marker level. The marker-delta reading at this point is the 20 dB bandwidth and 99% occupied bandwidth of the emission.

Because the measured signal is CW-like, adjusting the RBW per C63.10 would not be practical since measurement bandwidth will always follow the RBW. The RBW is set to 300 Hz to perform the occupied bandwidth test.

5.4.2 Test result

Frequency (kHz)	20dB emission bandwidth (Hz)
130.8	774.20

Test plots as below:

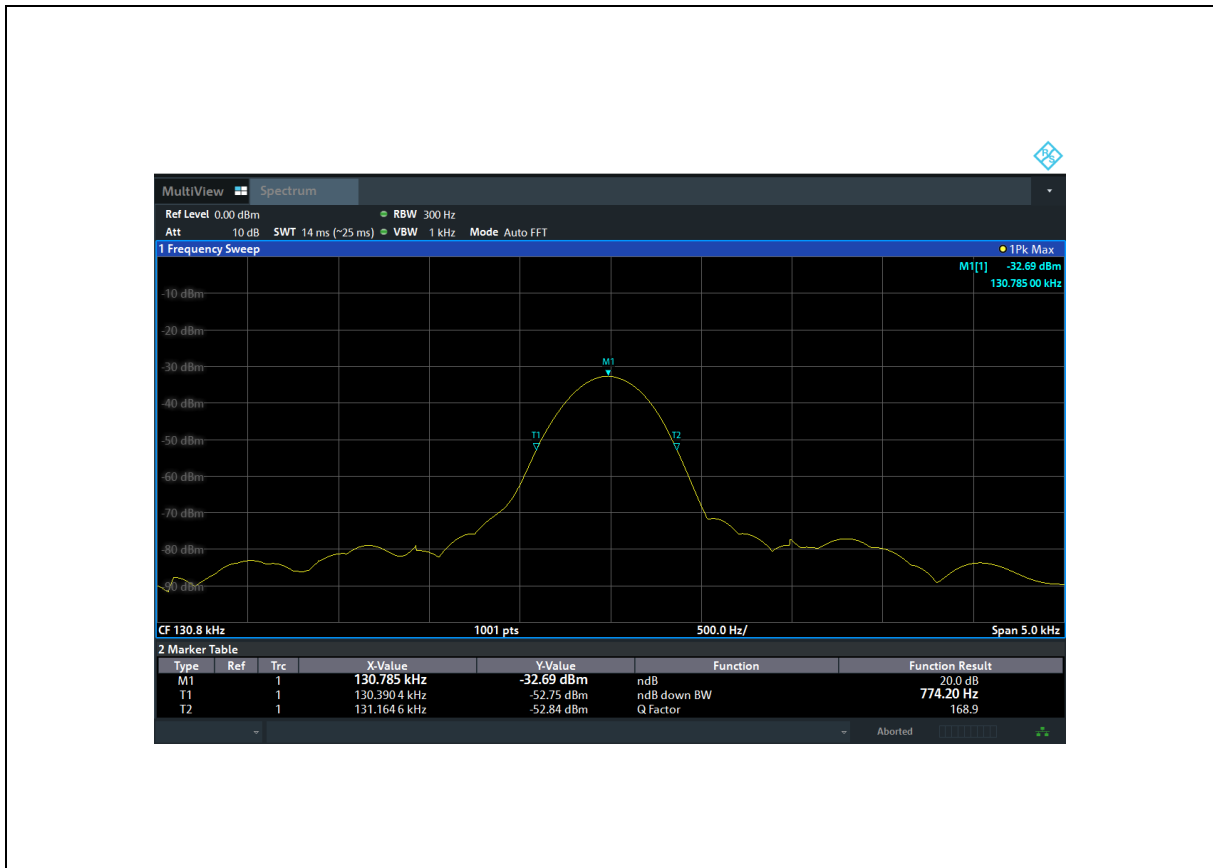

6 Photographs of the Test Setup

Radiated Emission Below 30MHz

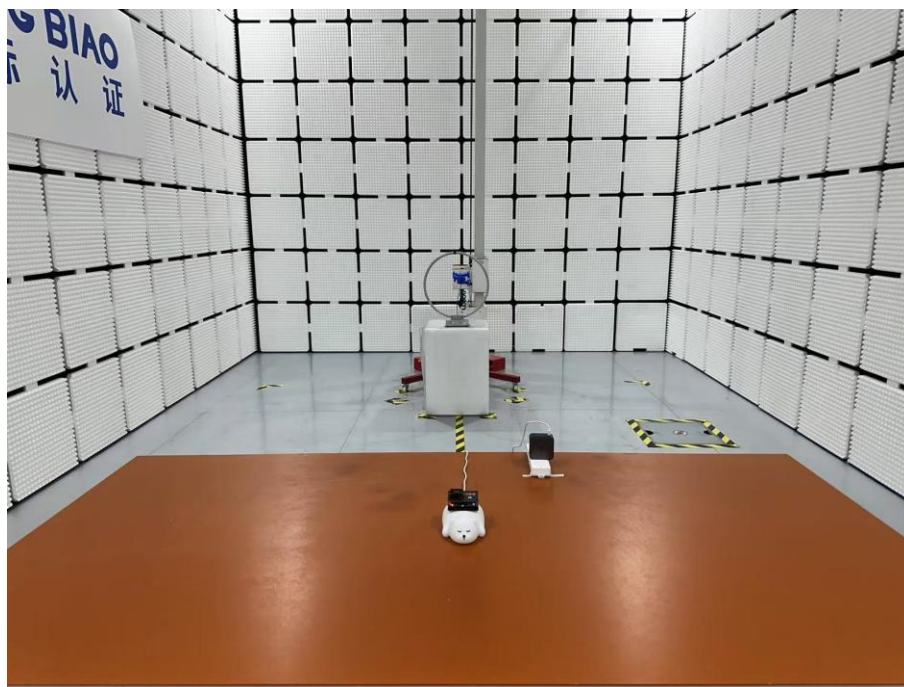

Radiated Emission Above 30MHz

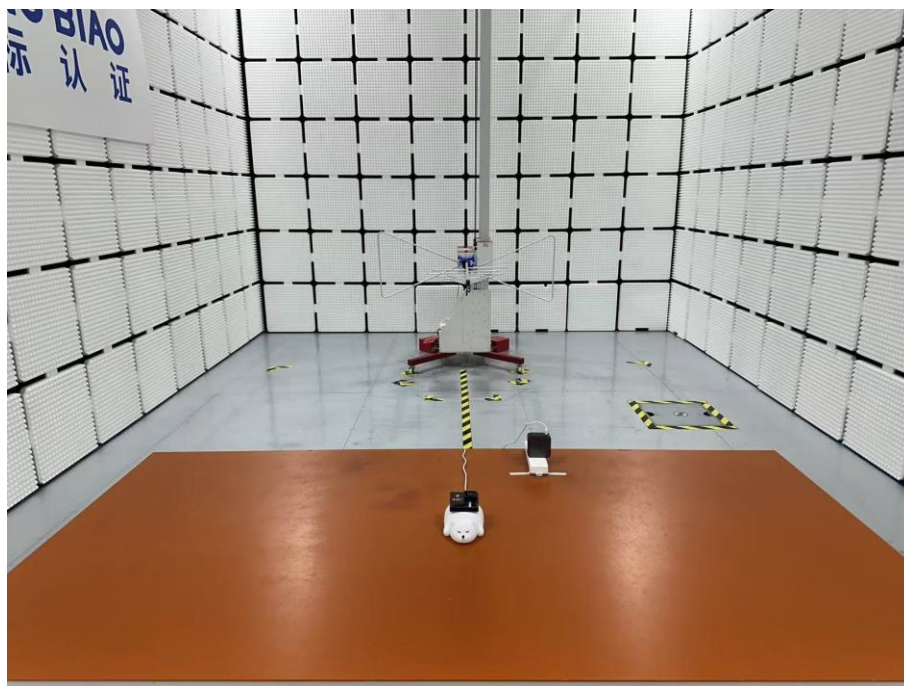

Conducted Emission

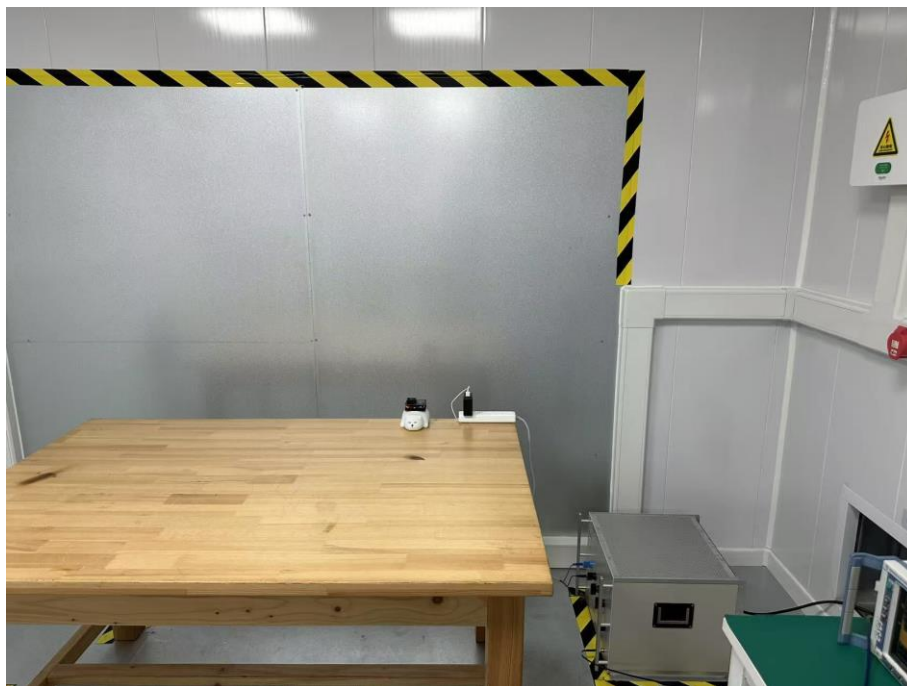

7 Photographs of the EUT

Photo 1



Photo 2



Photo 3



Photo 4



Photo 5



Photo 6



Photo 7



Photo 8

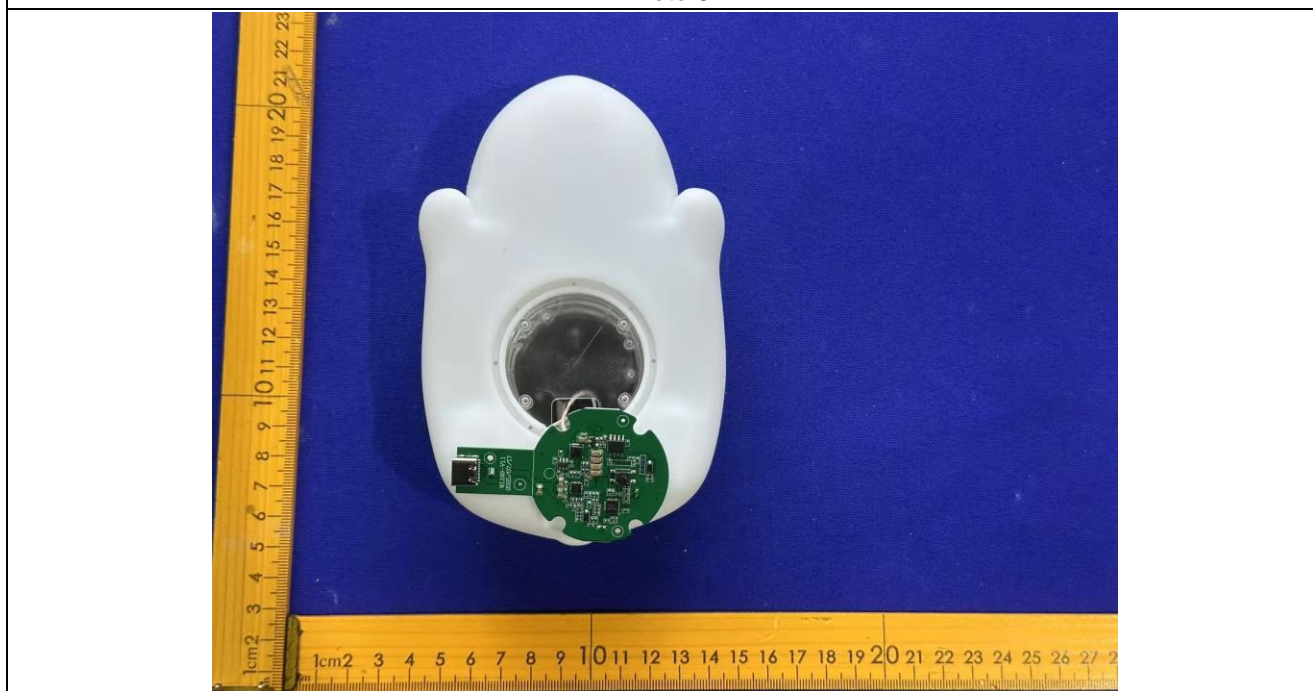

Photo 9

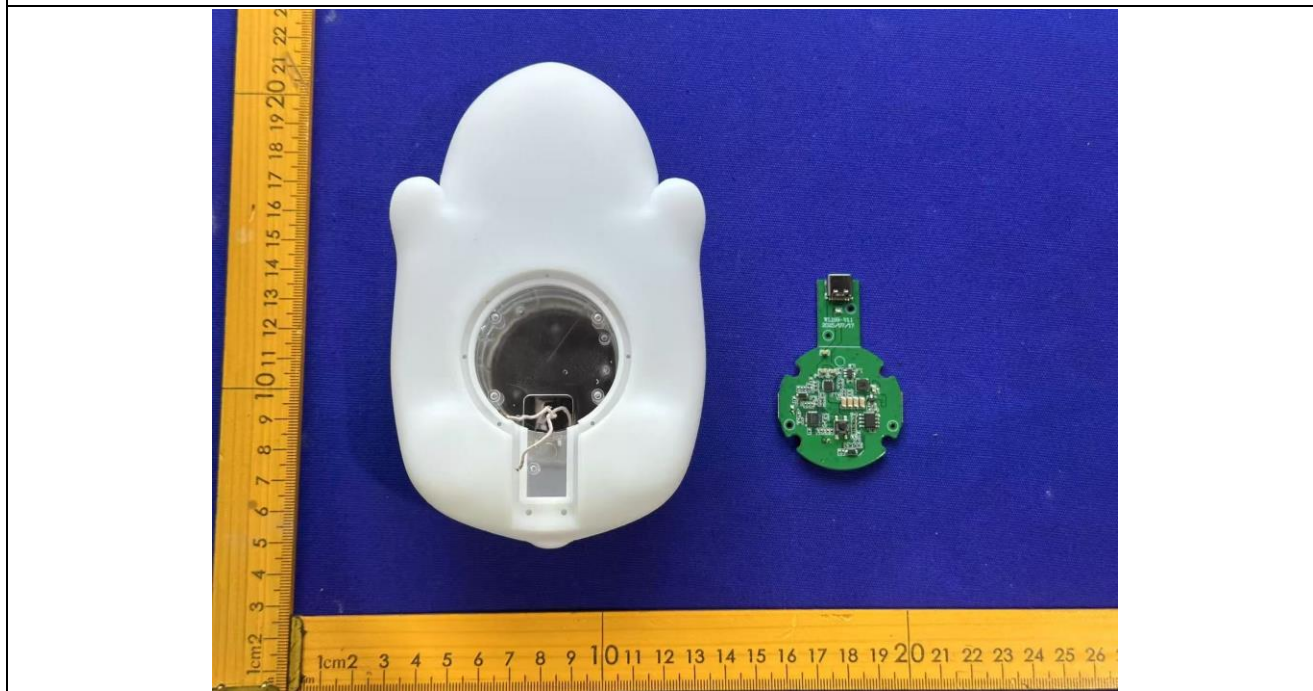

Photo 10



Photo 11



Photo 12

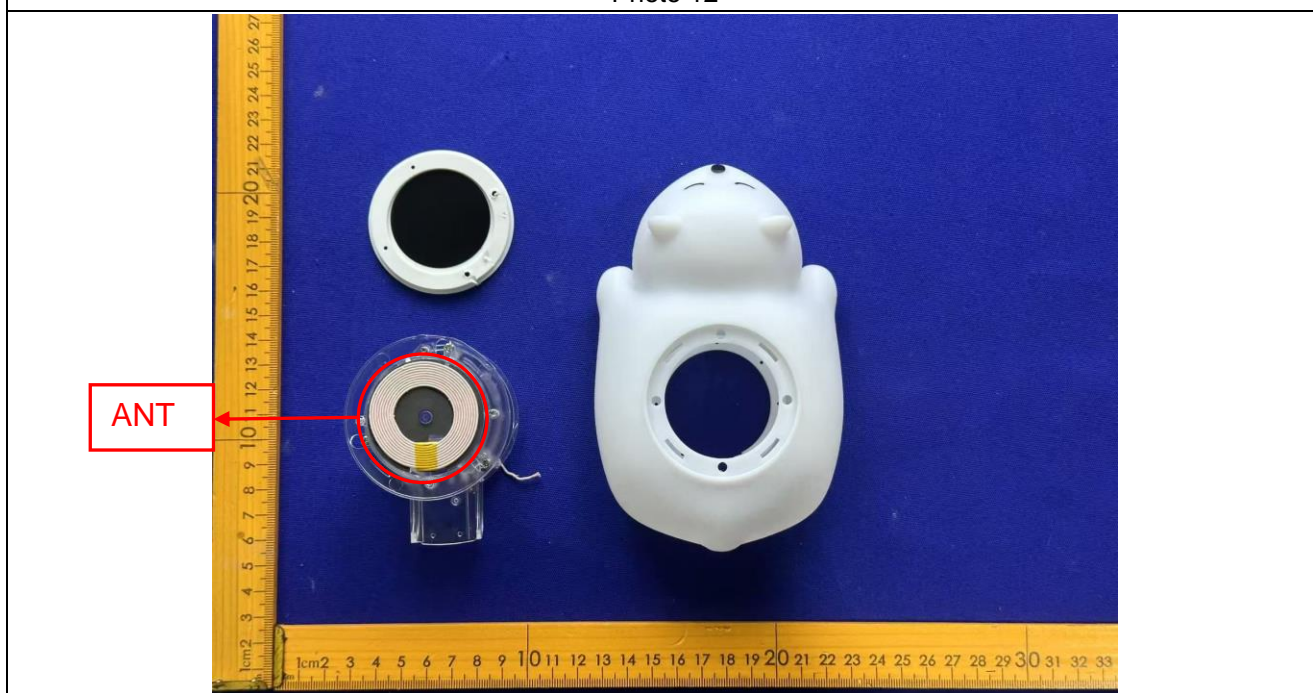

Photo 13

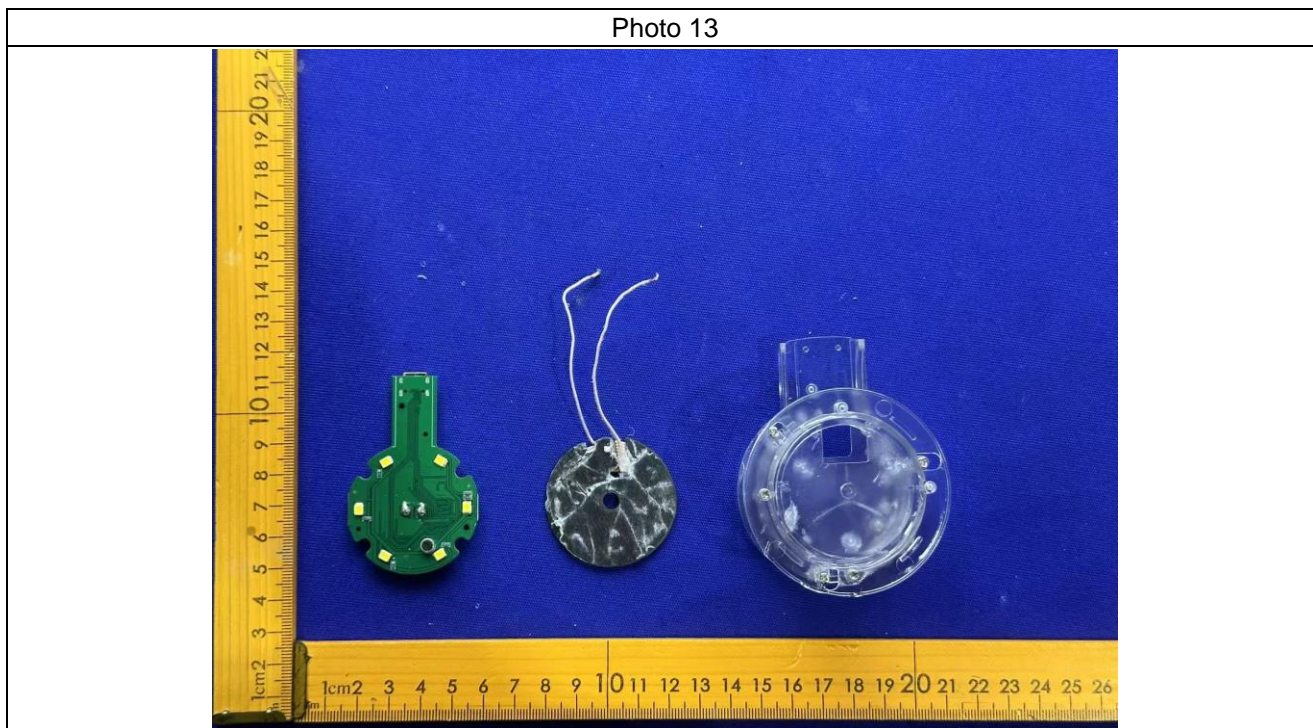

Photo 14

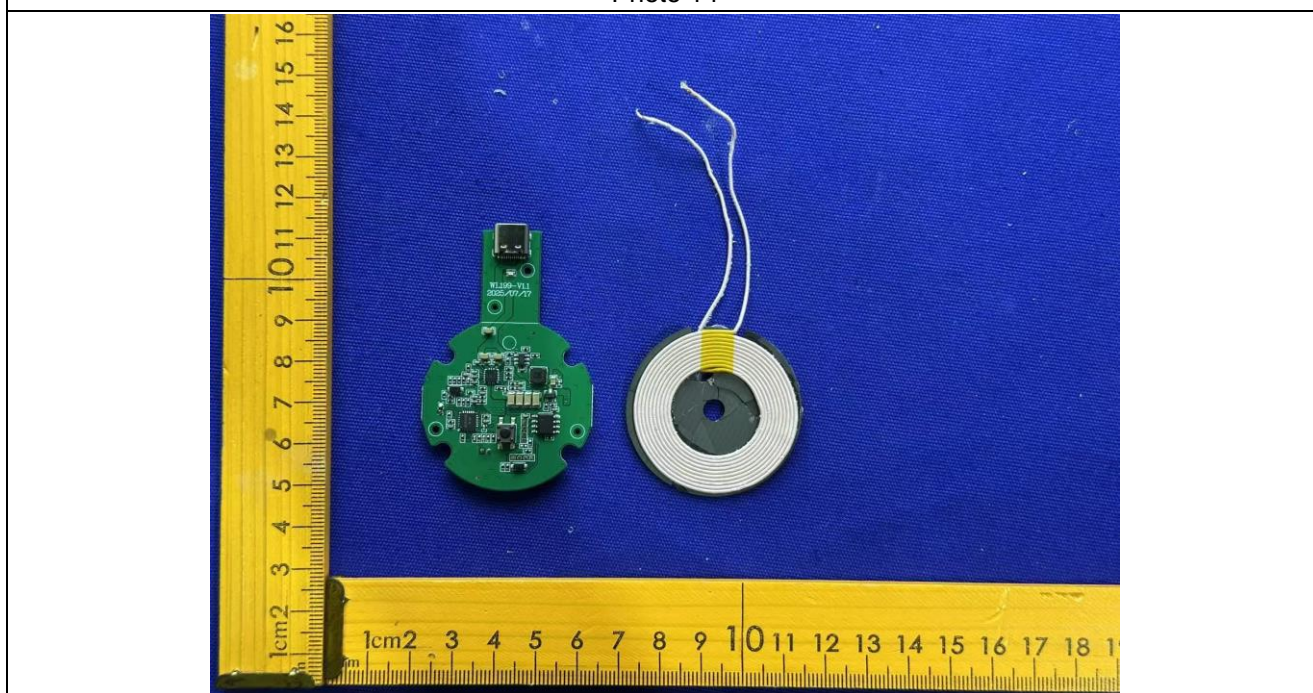

Photo 15

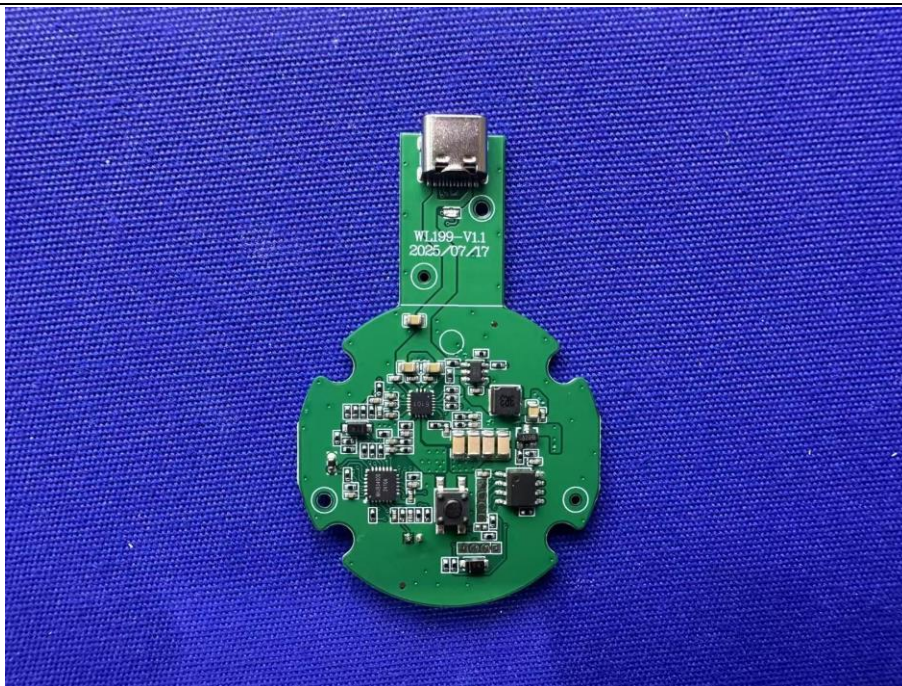
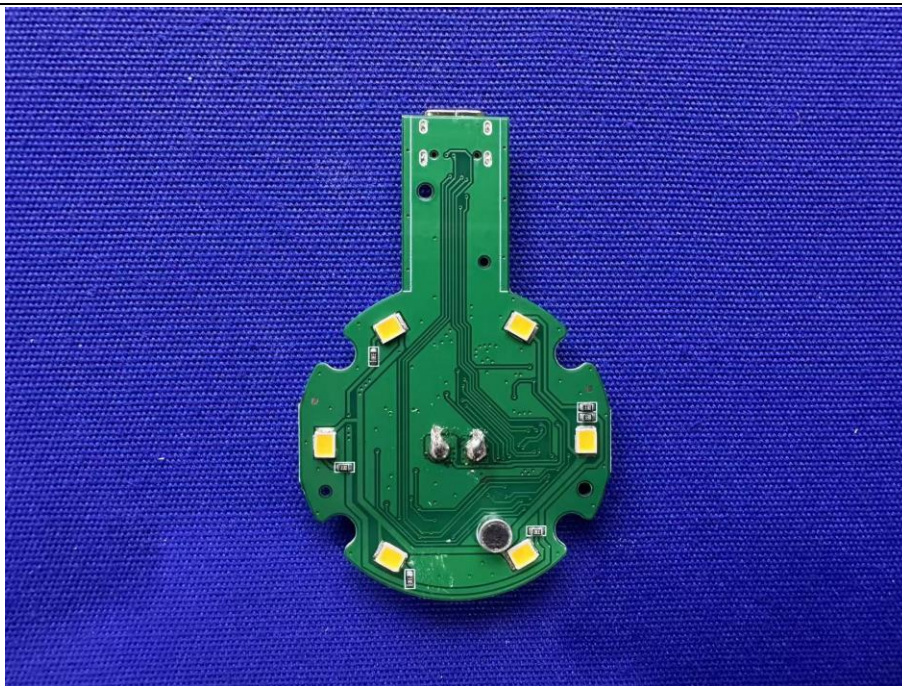

Photo 16



***** END OF REPORT *****