



APPLIED TEST LAB INC.

Page 1 of 56

FCC Part 15 TEST REPORT

DTS 4.0 (2400-2483.5 MHz)

Limits Applied: **FCC 15.247**

Report#: **A001E005-31**

FCC ID: **2AOSO1M01831**

Manufacturer: **L3 Mobile-Vision Inc.**

Model: **BWX-100 Camera System**

Serial Number: **Camera:214, Dock:307**

Test Start Date: **2017-12-18**

Test Completion Date: **2018-02-22**

Test Result: **PASS**

Report Issue Date: **2018-05-14**

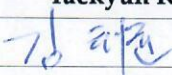
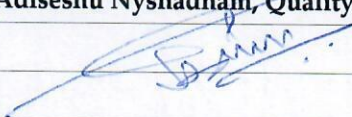
Tested by	Approved by:
Taekyun Kim, Test specialist 	Adishesu Nyshadham, Quality Prime 

Report Issued to	Report Issued by
L3 Mobile-Vision Inc. 400 Commons way, Suite F, Rockaway, NJ, 07866	Applied Test Lab Inc. Unit 4174-3961 52 Ave NE Calgary, AB, T3J 0J8

Report Revision History		
Rev	Description of Change	Date
Draft01	Initial	18-02-23
Release	Title Page and Information (Page 1, 6, 26, 31, 34, 35, 41, 58-60)	18-03-06
Rev 1	Title Page and Information (Page 1, 4, 6, 15-56)	18-05-14

Applied Test Lab Inc. (ATL) test facilities are recognized by FCC and Industry Canada to perform the test(s) listed in this report, except where noted otherwise. This report and the information contained herein represent the results of testing test articles identified and selected by the client performed to specifications and or procedures selected by the client. ATL makes no representations, expressed or implied, that such testing is adequate (or inadequate) to demonstrate efficiency, performance, reliability, or other characteristic of the article being tested, or similar products. This report should not be relied up on as an endorsement or certification by ATL of the equipment tested, nor does it represent any statement whatsoever as to its merchantability or fitness of the test article, or similar products, for a particular purpose. The report must not be used by client to claim product endorsement by FCC or Industry Canada. Any use which a third party makes of this report, or any reliance on or decisions to be made on it, are the responsibility of such third parties. ATL accepts no responsibility for damages suffered by any third party as a result of decisions made or actions based on this report. This report shall not be reproduced except in full without the written approval of ATL

This report contains 56 pages



Table of Contents

1.0 General.....	3
1.1 Purpose.....	3
1.2 Relevant Standards and References.....	3
1.3 Performance Requirement.....	3
1.4 Test Results Summary.....	4
1.5 Test Facility Information.....	4
1.6 Client Information.....	5
2.0 Test Sample Information.....	6
2.1 Equipment Under Test (EUT).....	6
2.2 Support Equipment and Details.....	7
2.3 I/O Ports and Details.....	7
2.4 I/O Cable Descriptions.....	7
3.0 Test Facilities.....	8
3.1 Semi-Anechoic Chamber Test Site Description.....	9
3.2 A diagram of the Semi-Anechoic Chamber Test Site.....	12
3.3 Test Equipment List.....	13
4.0 Test Setup Description.....	14
4.1 EUT System Block Diagram and Support Equipment.....	14
5.0 Test Methodology.....	15
5.1 Method of measurement of conducted disturbance.....	15
5.2 Method of measurement of radiated disturbance.....	15
5.3 Test Criteria.....	17
5.3.1 Conducted Emission Limits FCC 15.107.....	17
5.3.2 Radiated Emission Limits FCC 15.109 at a distance of 3 (m)	18
5.3.3 Radiated Emission Limits FCC Part 15.209/15.247(d) at a distance of 3 (m)	19
6.0 Test Results.....	20
6.1 FCC 15.247(b)(3) Conducted Output Power (2400-2483.5MHz DTS).....	20
6.2 FCC 15.247(d) RF Antenna Conducted Band Edge and Spurious Emissions.....	25
6.3 FCC 15. 247(d) Tx Radiated Spurious Emission & Band Edge.....	29
6.4 FCC 15.107 AC Conducted Emission Measurement.....	37
6.5 FCC15.109 Radiated Emission(30MHz - 1000MHz).....	45
6.6 FCC15.109 Radiated Emission(Above 1000MHz).....	49
7.0 Appendix A – Test Sample Description.....	52
8.0 Appendix B – List of Abbreviations and Acronyms.....	55



1.0 General

1.1 Purpose

The purpose of this report is to document conformance with FCC Part 15 Subpart C – 15.247(DTS) and to detail the results of testing performed on the sample Model: [BWX-100 Camera System](#) manufactured by [L3 Mobile-Vision Inc.](#). The test sample was received in good condition. Testing began [2017-12-18](#) on and was completed on [2018-02-22](#).

1.2 Relevant Standards and References

One or more of the following standards were used to evaluate the EUT:

1. **ANSI C63.4-2014:** American National Standard for Method of Measurements of Radio-Noise Emissions from Low-Voltage Electrical and Electronic Equipment in the 9 kHz to 40 GHz
2. **ANSI C63.10-2013:** American National Standard of Procedures for Compliance Testing of Unlicensed Wireless Devices
3. **US Code of Federal Regulations (CFR):** Part 15 Subpart B Title 47, Radio Frequency Devices - Unintentional Radiators
4. **US Code of Federal Regulations (CFR):** Part 15 Sub part C Title 47, Radio Frequency Devices - Intentional Radiators
5. **KDB 558074 D01 DTS Meas Guidance v04 2017-04** – Guidance for performing compliance measurements on Digital Transmission System(DTS) operating under section 15.247

1.3 Performance Requirement

The EUT is marketed as [FCC Part 15 Subpart C](#) equipment and must comply with the [FCC 15.247\(DTS\)](#) emission limits and requirements.

Maintenance of compliance is the responsibility of the manufacturer. Any modification of the product which may result in increase emission levels should be checked and verified to ensure continuous compliance has been maintained (i.e., printed circuit board layout changes, changes to filter performance, power supply changes, I/O cable and interface changes, critical component changes etc.)



1.4 Test Results Summary

Test Type	Basic Standard	Assessment	Limit/Requirement	Result
Frequency Hopping or Digital Modulation	15.247(a)	System uses Frequency Hopping Techniques		PASS
Conducted Output power	15.247(b)(3)	Full Power 12.00dBm (15.85 mW)	<1000mW (30 dBm)	PASS
Antenna Conducted Band Edge Emissions	15.247(d)/15.209	2390 MHz Level: -54.75dBc 2483.5 MHz Level:-57.43 dBc	<-30dBc	PASS
Antenna Conducted Spurious Emissions	15.247(d)/15.209	Highest Fundamental: 2480 MHz, 119.0 dBuV Highest Spurious: 24954.75MHz, -72.92 dBc,	<-30dBc	PASS
Tx Radiated Band Edge Emissions	15.247(d)/15.209	2390 MHz Level: -43.94 dBc 2483.5 MHz Level:-43.68 dBc	<-30dBc	PASS
Tx Radiated Spurious Emissions	15.247(d)/15.209	Highest Fundamental: 2402 MHz, 90.34 dBuV/m Highest Spurious: 4960.47MHz, -18.04dB	<-30dBc	PASS
RF connector	FCC 15.203	Integral Antenna	Integral Antenna or non-standard connector	PASS
Radiated Emission	15.109	Highest Emissions: 47.83MHz, 37.6 dBuV/m, -2.4 dB, Vertical Polarization	Refer to Standard	PASS
AC Conducted Emission	15.107	Highest Emissions: 0.209MHz, 49.67 dBuV, -4.62 dB, Line 2	Refer to Standard	PASS
Power Spectral Density	15.247(e)	-	<8 dBm	NP
6 dB Bandwidth	15.247(a)(2)	-	>= 0.5MHz	NP

NP=ATL was not contracted to perform the test.

There were no modifications to Body Camera, Dock was modified (please see details in section 7.0)

1.5 Test Facility Information

Name	Applied Test Lab Inc.				
Address	Unit 4174-3961 52 nd Avenue NE, Calgary, Alberta, T3J 0J8, Canada				
Telephone	403 590 8701		Fax	403 590 8570	
Email	emctestng@appliedtestlab.com		Website	www.appliedtestlab.com	
FCC Registration Number	950875	MRA Designation Number.	CA0004	IC Recognition	10988A



1.6 Client Information

Name	L3 Mobile-Vision Inc.		
Address	400 Commons way, Suite F, Rockaway, NJ, 07866		
Telephone	407 478 3636 ext)401	Website	www.mobile-vision.com
Contact Name	Kurt Kessel	Contact Email	Kurt.kessel@L3T.com



2.0 Test Sample Information

The **BWX-100 Camera System** was only operated and exercised in the mode(s) and configuration(s) described in this report. All inputs and outputs to and from support equipment associated with the **BWX-100 Camera System** were provided or simulated under the direction and responsibility of **L3 Mobile-Vision Inc.**. A description of these signals and their provision is included in Appendix A.

2.1 Equipment Under Test (EUT)

FCC ID	2AOSO1M01831
Product Description	Body Camera + Dock
Manufacturer	L3 Mobile-Vision Inc.
Model Number	BWX-100 Camera System
Serial Number	Camera:214, Dock:307
Model discrepancy/Variations	N/A
Power Supply and Requirements	POE or +5V AC/DC USB Adapter
Firmware Version	1.5.95
Software Version	N/A
Tx/Rx Channel Frequency Range	2402MHz – 2480MHz
Number of Channels	40
Carrier Frequency of Each Channel	40Channel(37 hopping + 3 advertising channel)
Maximum Output Power to Antenna (From original FCC Filing)	9.99dBm(0.010W)
99% Occupied Bandwidth (From original FCC Filing)	1.012MHz
Antenna Type and Gain	Antenna 1(Chip antenna type, 1.6dBi)
Modulation type(s)	Bluetooth 4.0 – LE:GFSK
Product Manufacturing Status	<input type="checkbox"/> Production Unit <input type="checkbox"/> Pre-Production Unit



2.2 Support Equipment and Details

 Applicable

Manufacturer	Description	Model No.	Serial Number	Other Info
ASUS	Laptop	S46CM-DH51-CA	9N0BC395958383	Emission
HP	Laptop	Elite book	PDXVC001X5UJ2N	Emission
NETGEAR	Ethernet router	FS108P	2HK1163E0191F	Emission
D-Link	Ethernet router	DGS-1008P	SY3L1H5001356	Emission
CUI Inc	AC/DC adapter	SWI10-5-N-138	N/A	Emission

2.3 I/O Ports and Details

 Applicable

Port Type	Description	Filter Info	Shielding Info	Other Info
USB	C type	No	Shielded	-
USB	Micro B Type	No	Shielded	-
Ethernet	Ethernet	No	UnShielded	-

2.4 I/O Cable Descriptions

 Applicable

Cable Description	Length (m)	Port From	Port To	Cable Type	Remarks
USB cable	0.9	AC/DC adapter	EUT	Shielded	Emission
Ethernet cable	>5	Ethernet router	EUT	Shielded	Emission



3.0 Test Facilities

Laboratory Location



The radiated and conducted emission test sites are located at the following address:

Applied Test Lab,
Unit 4174, 3961-52 Ave N.E., Calgary, AB T3J 0J8

Laboratory Accreditation/Recognitions/Certifications

The Semi-Anechoic Chamber Test Site and Conducted Emission Site have been fully described, submitted to, and accepted by the FCC and Industry Canada for testing Interference by information technology equipment. In addition, ATL has implemented an interim in-house quality system which is based on the ISO 17025 standard and is actively pursuing to achieve its accreditation. The following certification numbers have been issued in recognition of the certifications:

FCC Registration Number: **950875**
Industry Canada Lab Code: **IC 10988A**

Country	Agency	Accreditation/Certification	LOGO
USA	FCC	3 (m) Semi-Anechoic Chamber to perform FCC Part 15/18 measurements	
Canada	Industry Canada	3 (m) Semi-Anechoic Chamber to perform ICES-004 and RSS measurements	

Note: Unless otherwise specified, ATL performs the tests using standard test methods to evaluate the EUT for compliance to the defined International standards. However, the report is not to be used to claim compliance, certification or endorsement by FCC or Industry Canada or any other government agency unless specifically submitted to such agency for such purpose.



3.1 Semi-Anechoic Chamber Test Site Description

The Semi-Anechoic Chamber Test Site consists of a 6.24 x 9.144 x 5.79 (m) shielded enclosure. The chamber is lined with SAMWAH Ferrite Grid Absorber, model number SN-20. The ferrite tile grid is 100 x 100x 6.7 (mm) thick and weighs approximately 200 (grams). These tiles are mounted on steel panels and installed directly on the inner walls of the chamber. Inner side Wall is lined by 600H Foam Absorber with White Cap. Chamber is illuminated by set of 12 Incandescent Bulbs.

The turntable is 198 (cm) in diameter and is located 160 (cm) from the back wall of the chamber. The chamber is grounded via Utility Ground installed at the side of the back East wall, it is bound to the Chamber ground Stud using 1/2" copper braided cable.

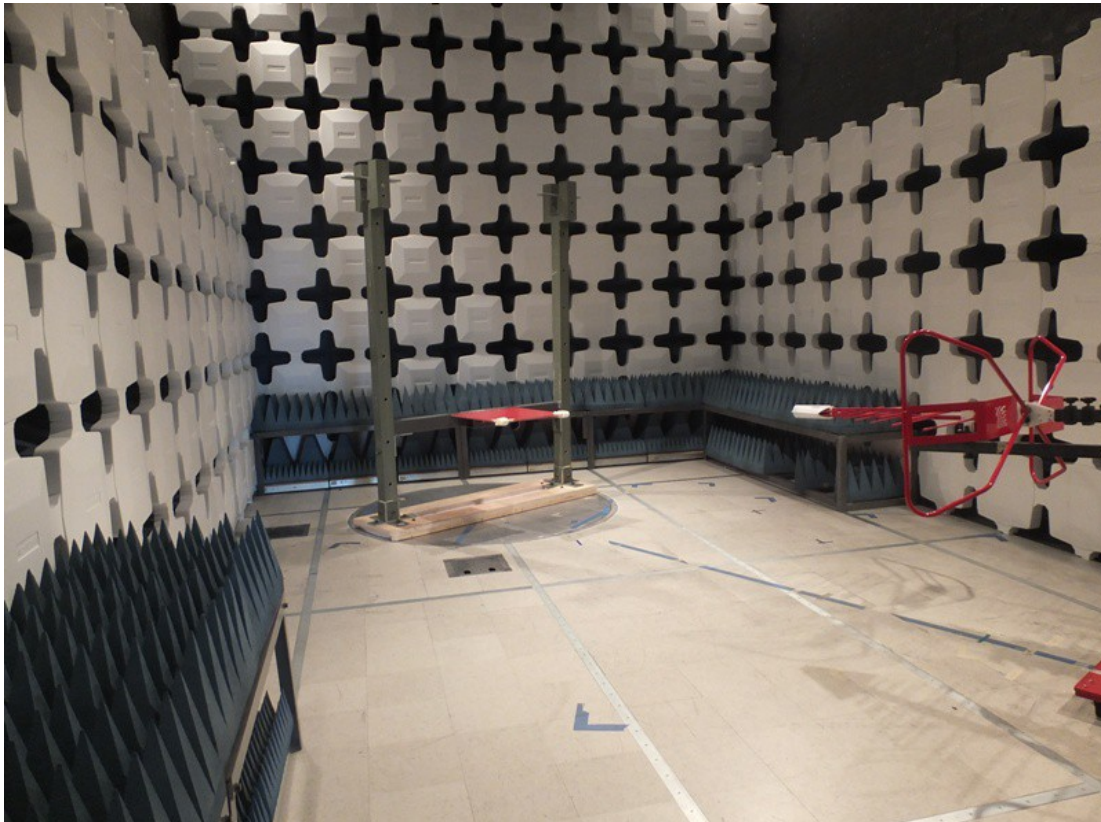

Figure 3.1 - Test Facility (Setup for 30MHz - 1000MHz)



Figure 3.2 - Test Facility (Setup for 1GHz - 18GHz)

The turntable is all aluminum, flush mounted table installed in an all steel frame. The table is remotely operated from the control area located outside the Semi Anechoic Chamber. The turntable is electrically bonded to the surrounding ground plane via steel fingers installed on the edge of the turn table. The steel fingers make constant contact with the ground plane during operation.

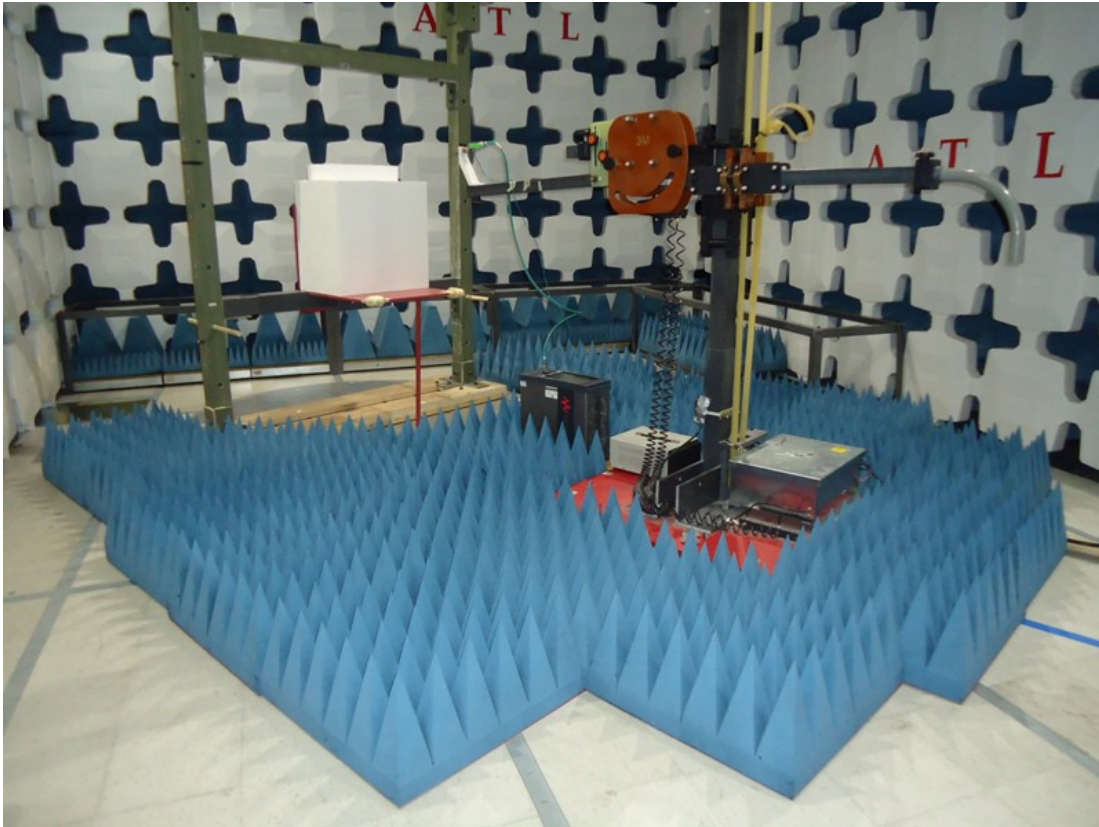

Figure 3.3 - Test Facility (Setup for 18GHz - 26GHz)



3.2 A diagram of the Semi-Anechoic Chamber Test Site

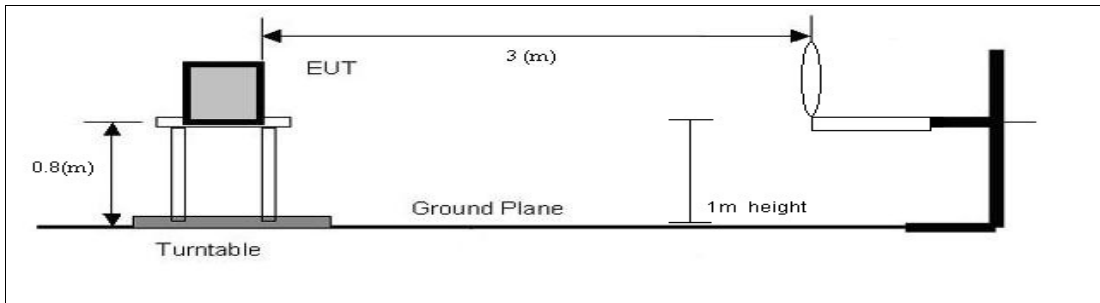

Figure 3.4 - Semi- Anechoic chamber diagram(0.009MHz - 30MHz)

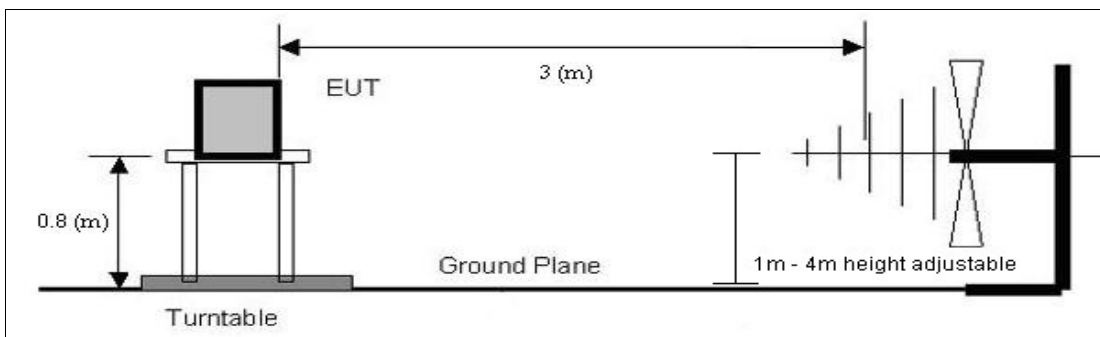

Figure 3.5 - Semi- Anechoic chamber diagram(30MHz - 1000MHz)

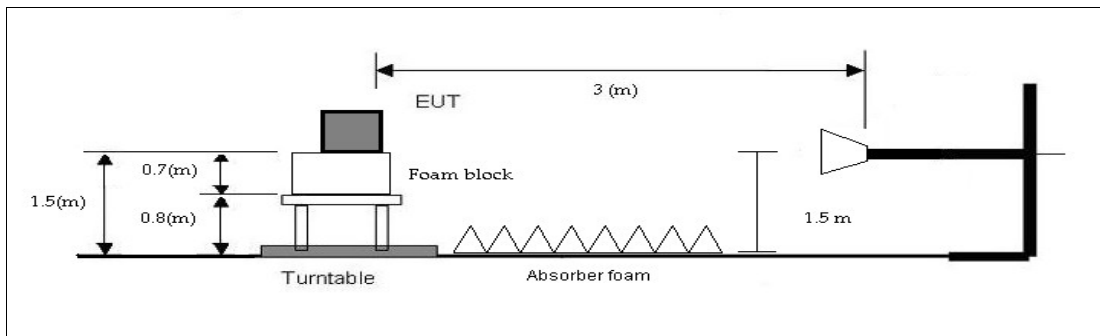

Figure 3.6 - Semi- Anechoic chamber diagram(1000MHz - 18000MHz)

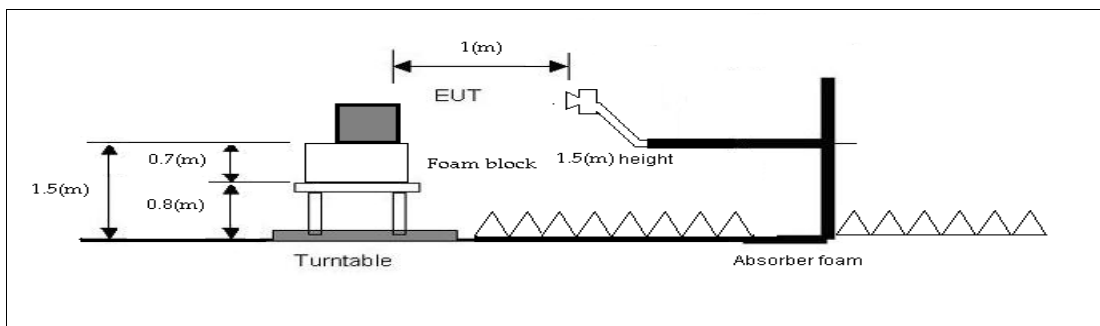

Figure 3.7 - Semi- Anechoic chamber diagram(18000MHz - 26000MHz)



3.3 Test Equipment List

Table 3.1 - Test Equipment used for Radiated Emission

Description	Manufacturer	Model Number	Serial Number	Next Cal
Bi-Log antenna	ETS Lindgren	3142E	144760	April 29, 2018
Double Ridged Horn	ETS Lindgren	3117	143094	May 5, 2019
Spectrum Analyzer	Hewlett Packard	Hp8593EM	3639A00172	February 18, 2018
EMI Receiver & RF filter section	Hewlett Packard	8546A, 85460A	3448A00267, 3448A00245	May 13, 2018
MXA Signal Analyzer	Keysight	N9020B-526	SG56080714	October 13, 2019
Cable	Micro Coax UTIFLEX	UFB293C	303	PV
Cable	Micro Coax UTIFLEX	UFB311A	SFC220863	PV
Cable	Micro Coax UTIFLEX	UFA210B-0-0120-50250	96G1557	PV
Turntable	ETS Lindgren	2187	NA	NCR
Antenna Bore-sight Mast	ETS Lindgren	2071B	136243	NCR
Multi Device Controller	ETS Lindgren	ETS 2090	148017	NCR
3 Meter chamber	ETS Lindgren	FACT 3-2.0	N/A	March 27, 2018
LNA	MITEQ	AMF-7D-01001800-22-10P	1782797	PV
LNA	Wenteq Microwave CORP	ABL0300-00-4030	N/A	PV
DC power supply	Instek	PC-3030	9503310	PV
Test SW	DVT Solutions Inc	REDvtAtIV3p29.exe - (20170610)		

NOTE: The measurement uncertainty is less than +/- 4.4 (dB) which is evaluated as per the NAMAS NIS 81 and CISPR 16-4-2

NCR: No Calibration required.

PV: Periodic Verification



4.0 Test Setup Description

4.1 EUT System Block Diagram and Support Equipment

Applicable

UUT powered with POE (Power-Over-Ethernet)

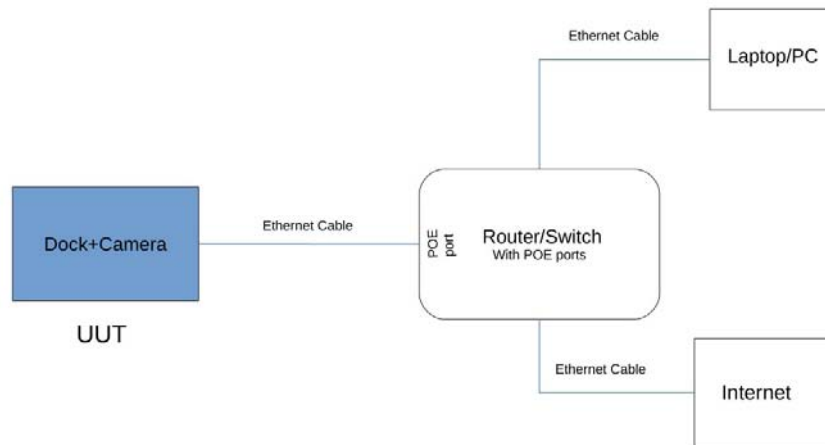

Figure 4.1a - EUT System Block Diagram and Support Equipment

UUT connected with Standard AC/DC USB Adapters

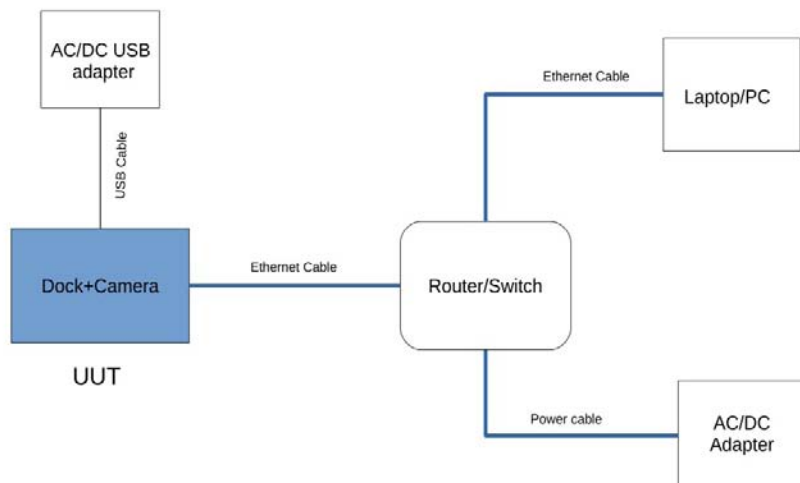

Figure 4.1b - EUT System Block Diagram and Support Equipment



5.0 Test Methodology

5.1 Method of measurement of conducted disturbance

Conducted Emission measurements were made over the frequency range of 150 (kHz) to 30 (MHz). The software is programmed to perform a peak sweep of the frequency band using the max hold function. This sweep is performed for every power conductor of the power line. During the sweep measurement the Spectrum Analyzer/Receiver's resolution bandwidth set to 9 (kHz) and the video bandwidth set to 30 (kHz). Although not a fully maximized scan, this type of scan provides emission data with a good indication of pass or fail.

Quasi- Peak measurements are taken with the Spectrum Analyzer/Receiver's resolution bandwidth set to 9 (kHz) and Video Bandwidth set to 30 (kHz). Average measurements are taken with the resolution bandwidth set to 9 (kHz) and the video bandwidth set to 30 (kHz): The calculation for the radiated emission field strength is as follows:

$$\begin{aligned}\text{Corrected Reading (dBuV)} &= \text{Analyzer/Receiver Reading(dBuV)} + \text{Correction Factor (dB)} \\ \text{Correction Factor (dB)} &= \text{LISN Insertion Loss(dB)} + \text{Cable Insertion Loss(dB)} + \text{Transient Limiter Insertion} \\ &\quad \text{Loss(dB)} \\ \text{Margin(dB)} &= \text{Corrected Reading(dBuV)} - \text{Applicable Limit(dBuV)}\end{aligned}$$

5.2 Method of measurement of radiated disturbance

Measurement below 1 (GHz)

Measurements shall be made with a quasi-peak measuring receiver in the frequency range 30 (MHz) to 1000 (MHz). To reduce the testing time, a peak measuring receiver may be used instead of a quasi-peak measuring receiver. In case of dispute, measurement with a quasi-peak measuring receiver will take precedence.

The quasi-peak measuring receiver shall be in accordance with Clause 4 of CISPR 16-1-1. Receivers with peak detectors shall be in accordance with Clause 5 of CISPR 16-1-1 and shall have a 6 (dB) bandwidth in accordance with Clause 4 of CISPR 16-1-1. The antenna shall be a balanced dipole. For frequencies of 80 (MHz) or above, the antenna shall be resonant in length, and for frequencies below 80 (MHz) it shall have a length equal to the 80 (MHz) resonant length. Further detailed information is given in Clause 4 of CISPR 16-1-4.

Of those disturbances above ($L - 20$ dB), where L is the limit level in logarithmic units, record at least the disturbance levels and the frequencies of the six highest disturbances. Record the antenna polarization for each reported disturbance.

The software is programmed to perform a peak sweep of the frequency band using the max hold function. This sweep is performed every 22.5 (deg) in both horizontal and vertical polarities and at antenna heights of 100, 200 300 and 400 (cm). Although not a fully maximized scan, this type of scan provides emission data with a good indication of pass or fail.



Measurement above 1 (GHz)

The measurement instrumentation shall be as specified in CISPR 16-1-1.

The measuring antennas shall be as specified in 4.6 of CISPR 16-1-4.

The measuring site shall be as specified in 8 of CISPR 16-1-4.

The measurement method shall be as specified in 7.3 of CISPR 16-2-3.

The peak detector limits shall not be applied to disturbances produced by arcs or sparks that are high voltage breakdown events. Such disturbances arise when ITE devices contain or control mechanical switches that control current in inductors, or when ITE devices contain or control subsystems that create static electricity (such as paper handling devices). The average limits apply to disturbances from arcs or sparks, and both peak and average limits will apply to other disturbances from such ITE devices.

Compliance Scans

Radiated emission measurements were made over the frequency range of 30 (MHz) to 1000 (MHz). Quasi-peak measurements are taken with the Spectrum Analyzer/Receiver 's Resolution Bandwidth set to 120 (kHz) and Video Bandwidth set to 300 (kHz) for measurements below 1 (GHz). Average measurements are taken with the Resolution Bandwidth set to 1 (MHz) and the Video Bandwidth set to 1 (MHz) for measurements above 1000 (MHz). For unintentional radiators other than ITE, for each of the frequencies to which the device is tuned, the frequency and amplitude of the six highest radiated emissions relative to the limit and the operating frequency, or frequency to which the EUT is tuned (if appropriate), shall be reported unless such emissions are more than 20 (dB) below the limit. If less than the specified number (less than six) emissions are within 20 (dB) of the limit, the noise level of the measuring instrument at representative frequencies shall be reported.

The polarization of the measurement antenna (horizontal or vertical) shall be identified for each of the reported emissions. Radiated emission measurements taken at alternative distances are to be converted to the limit distance using the inverse distance relationship, unless data can be presented to validate a different conversion. At a reported frequency, the polarization with the highest level shall be reported. The calculation for the radiated emission field strength is as follows:

$$\text{Corrected Reading (dBuV/m)} = \text{Analyzer/Receiver Reading(dBuV)} + \text{Correction Factor(dB/m)}$$

$$\text{Correction Factor (dB/m)} = \text{Cable Loss(dB)} + \text{Antenna Factor(dB/m)}$$

$$\text{Margin (dB)} = \text{Corrected Reading(dBuV/m)} - \text{Applicable Limit(dBuV/m)}$$



5.3 Test Criteria

5.3.1 Conducted Emission Limits FCC 15.107

Class A: An ITE meeting the conditions for Class A operation shall comply with the Class A conducted limits set out in Table 5.1. **Applicable**

Table 5.1 - Class A Conducted Emission Limits (FCC)

Emission Type	Frequency Range (MHz)	FCC (dBuV)	
		Quasi-peak	Average
Conducted Emission	0.15 - 0.5	79	66
	0.5 - 30	73	60

Class B: An ITE meeting the conditions for Class B operation shall comply with the Class B conducted limits set out in Table 5.2. **Applicable**

Table 5.2 - Class B Conducted Emission Limits (FCC)

Emission Type	Frequency Range (MHz)	FCC (dBuV)	
		Quasi-peak	Average
Conducted Emission	0.15 - 0.5	66 linear to 56	56 linear to 46
	0.5 - 5	56	46
	5 - 30	60	50



5.3.2 Radiated Emission Limits FCC 15.109 at a distance of 3 (m)

Radiated emission from an ITE shall be measured from the lowest frequency generated, or used, in the device or 30 (MHz), whichever is higher, up to the frequency determined in accordance with Table 5.3

Table 5.3 - Frequency Range of Measurement

Highest Frequency Generated or Used in Device	Upper Frequency of Radiated Measurement
Below 1.705 MHz	No radiated testing required
1.705 MHz - 108 MHz	1000 (MHz)
108 MHz - 500 MHz	2000 (MHz)
500 MHz - 1000 MHz	5000 (MHz)
Above 1000M Hz	5th harmonic of the highest frequency or 40000 (MHz), whichever is lower.

Class A: An ITE meeting the conditions for Class A operation defined in Section 1.3 shall comply with the Class A radiated limits set out in Table 5.4 determined at a distance of 3 (m).

Applicable

Table 5.4 - Class A Radiated Emission Limits(FCC)

Emission Type	Frequency Range (MHz)	FCC @ 3 (m) (dBuV/m)	
		Quasi-peak	Average
Radiated Emission	30 - 88	49.54	-
	88 - 216	53.98	-
	216 - 960	56.90	-
	960 - 1000	60	-
	Above 1000	-	60

Class B: An ITE that does not meeting the conditions for Class A operation shall comply with the Class B radiated limits set out in Table 5.5 determined at a distance of 3 (m).

Applicable

Table 5.5 - Class B Radiated Emission Limits (FCC)

Emission Type	Frequency Range (MHz)	FCC @ 3 (m) (dBuV/m)	
		Quasi-peak	Average
Radiated Emission	30 - 88	40	-
	88 - 216	43.52	-
	216 - 960	46.02	-
	960 - 1000	53.89	-
	Above 1000	-	53.98



5.3.3 Radiated Emission Limits FCC Part 15.209/15.247(d) at a distance of 3 (m)

Frequency range of radiated measurements.

(a) Unless otherwise noted in the specific rule section under which the equipment operates for an intentional radiator the spectrum shall be investigated from the lowest radio frequency signal generated in the device, without going below 9 kHz, up to at least the frequency shown in this paragraph:

- (1) If the intentional radiator operates below 10 GHz: to the tenth harmonic of the highest fundamental frequency or to 40 GHz, whichever is lower.
- (2) If the intentional radiator operates at or above 10 GHz and below 30 GHz: to the fifth harmonic of the highest fundamental frequency or to 100 GHz, whichever is lower.
- (3) If the intentional radiator operates at or above 30 GHz: to the fifth harmonic of the highest fundamental frequency or to 200 GHz, whichever is lower, unless specified otherwise elsewhere in the rules.
- (4) If the intentional radiator contains a digital device, regardless of whether this digital device controls the functions of the intentional radiator or the digital device is used for additional control or function purposes other than to enable the operation of the intentional radiator, the frequency range shall be investigated up to the range specified in paragraphs (a)(1)-(a)(3) of this section or the range applicable to the digital device, as shown in paragraph (b)(1) of this Section, whichever is the higher frequency range of investigation.

Applicable

Table 5.6 - Radiated Emission Part 15.209 Limits(FCC)

Emission Type	Frequency Range (MHz)	FCC @ 3 (m) (dBuV/m)	
		Quasi-peak	Average
Radiated Emission	0.009 - 0.490	-	128.52 to 93.8
	0.490 - 1.705	-	73.8 to 62.97
	1.705 - 30	-	69.54
	30 - 88	40	-
	88 - 216	43.52	-
	216 - 960	46.02	-
	960 - 1000	53.98	-
	Above 1000	-	53.98
	2400 - 2483.5	-	137



6.0 Test Results

6.1 FCC 15.247(b)(3) Conducted Output Power (2400-2483.5MHz DTS)

 Applicable

Table 6.1 – Power Output(2400-2483.5MHz DTS) information

CLIENT:	L3 Mobile-Vision Inc.	TEST STANDARD:	FCC 15.247(b)(3)
MODEL NUMBER:	BWX-100 Camera System	PRODUCT:	Body Camera + Dock
SERIAL NUMBER:	Camera:214, Dock:307	CLASS:	FCC 15.247
TEMPERATURE:	20°C	HUMIDITY:	20%
TESTED BY:	Taekyun Kim	DATE OF TEST:	2018-02-15
TEST REFERENCE:	ANSI C63.10(2013), KDB 558074(April 5, 2017)		
TEST VOLTAGE:	3.42VDC, 3.85VDC, 4.2VDC		
SETUP:	<p>The EUT is DC powered through a DC power supply.</p> <p>The EUT is continuously transmitting. Low, Mid and High channels as well as all data rates were investigated, worst case data reported. The EUT was fitted with a temporary antenna port for direct conducted measurements.</p>		
FREQUENCY RANGE	Fundamental		
FREQUENCY TESTED:	2402MHz, 2440MHz, 2480MHz		
FIRMWARE POWER SETTING	Max power		
EUT FIRMWARE	1.5.95		
MODULATION/DATA RATE	All data rates were investigated, 1Mbps data rate was found to be worst case.		
ANTENNA TYPE/GAIN	Antenna 1(Chip antenna type, 1.6dBi)		
DUTY CYCLE	100%		
RESULTS:	PASS		

**Table 6.2 – Test Data Summary – Voltage Variations**

Voltage Variations					
Frequency (MHz)	Modulation	3.42VDC (dBm)	3.85VDC (dBm)	4.2VDC (dBm)	Max Deviation from 3.85VDC (dB)
2402	1M Data Rate	11.76	11.74	11.74	-0.02
2440	1M Data Rate	11.84	11.87	11.85	0.03
2480	1M Data Rate	12.01	12.00	12.03	-0.03

Table 6.3 – Power Output Test Data Summary – RF Conducted Measurement

Power Output Test Data Summary – RF Conducted Measurement					
Frequency	Modulation	Ant. Type/ Gain (dBi)	Measured (dBm)	Limit (dBm)	Result
2412	1M Data Rate	1.6	11.74	30	PASS
2437	1M Data Rate	1.6	11.87	30	PASS
2462	1M Data Rate	1.6	12.00	30	PASS

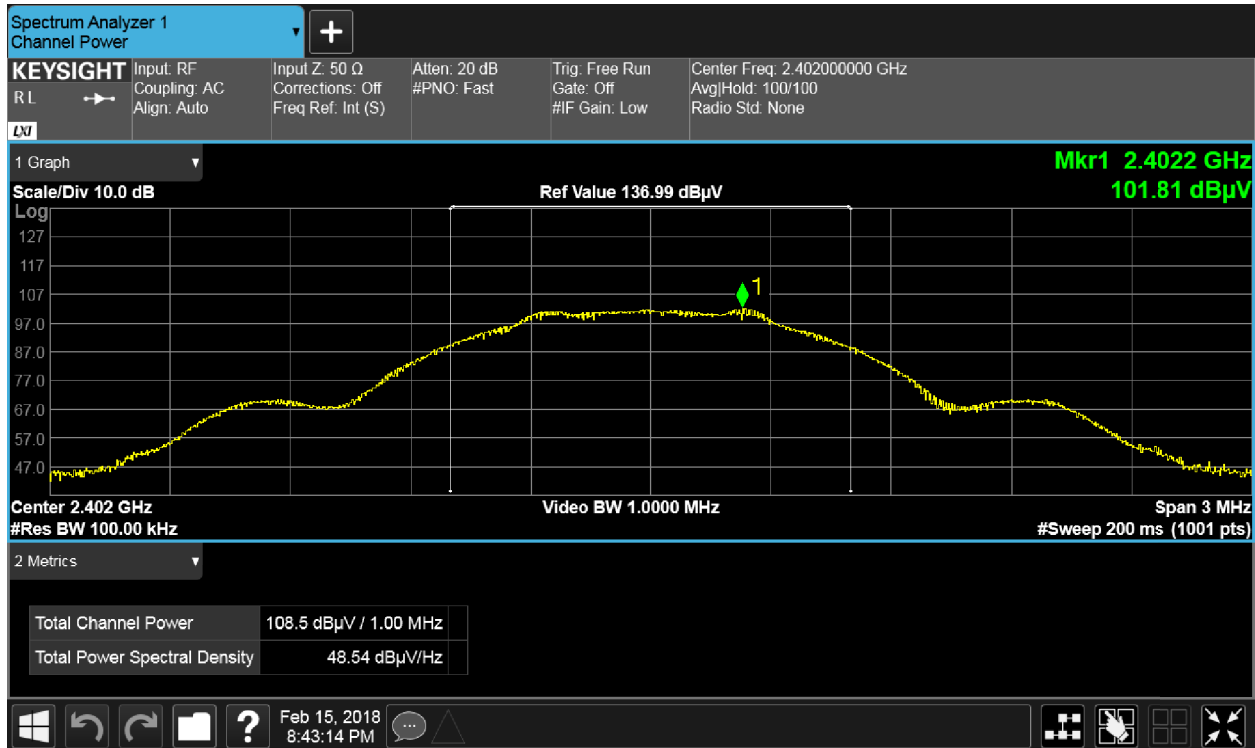

Figure 6.1 – Channel 0, Data rate 1M Data.

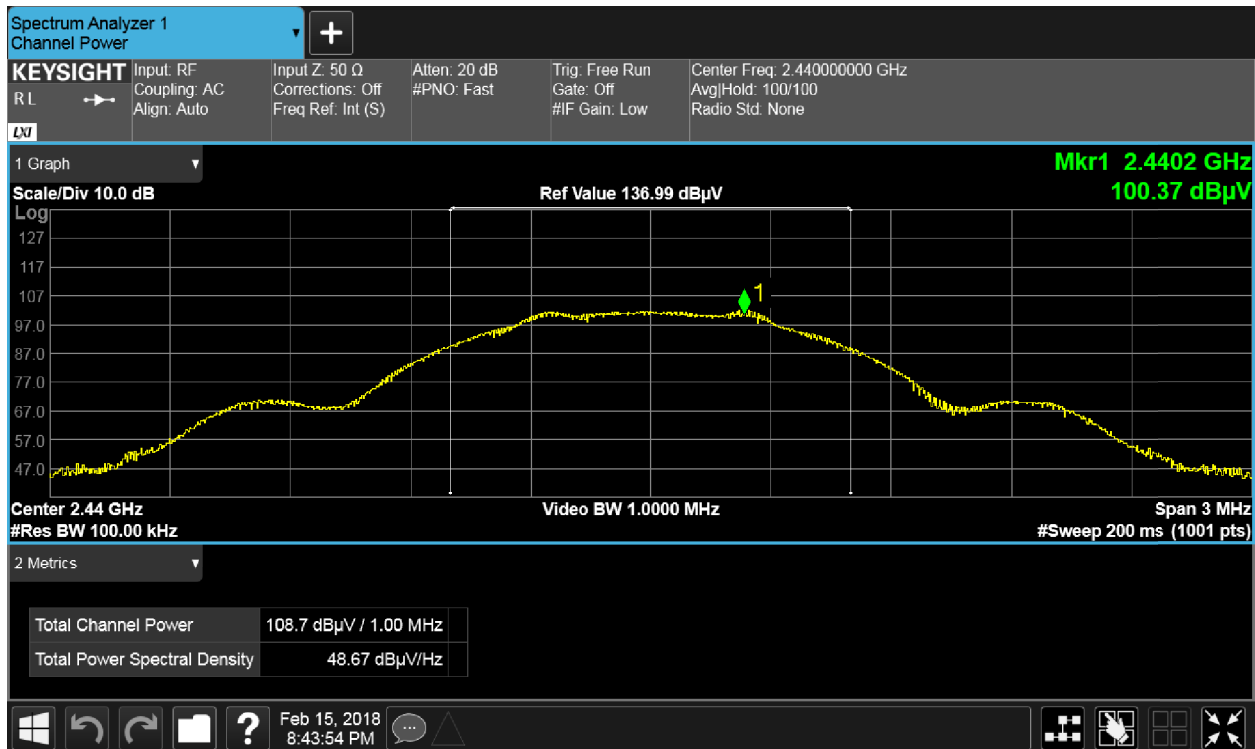

Figure 6.2 - Channel 19, Data rate 1M Data.

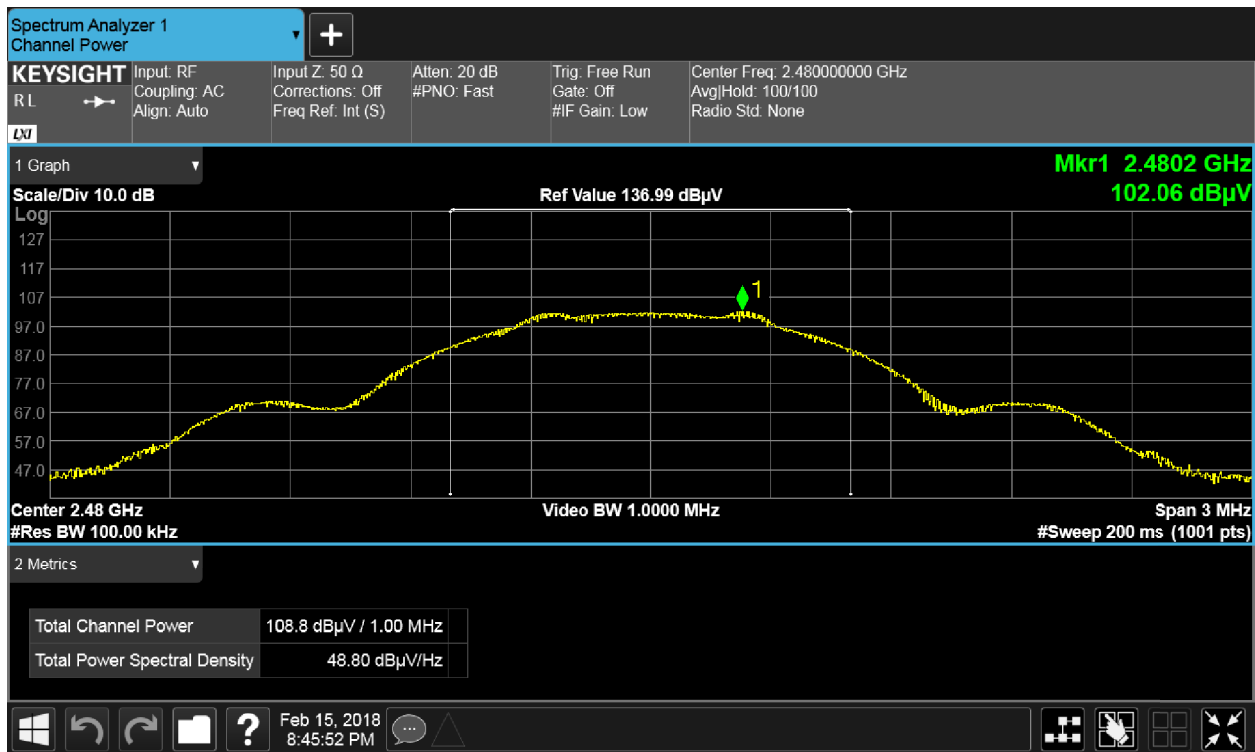

Figure 6.3 – Channel 39, Data rate 1M Data.

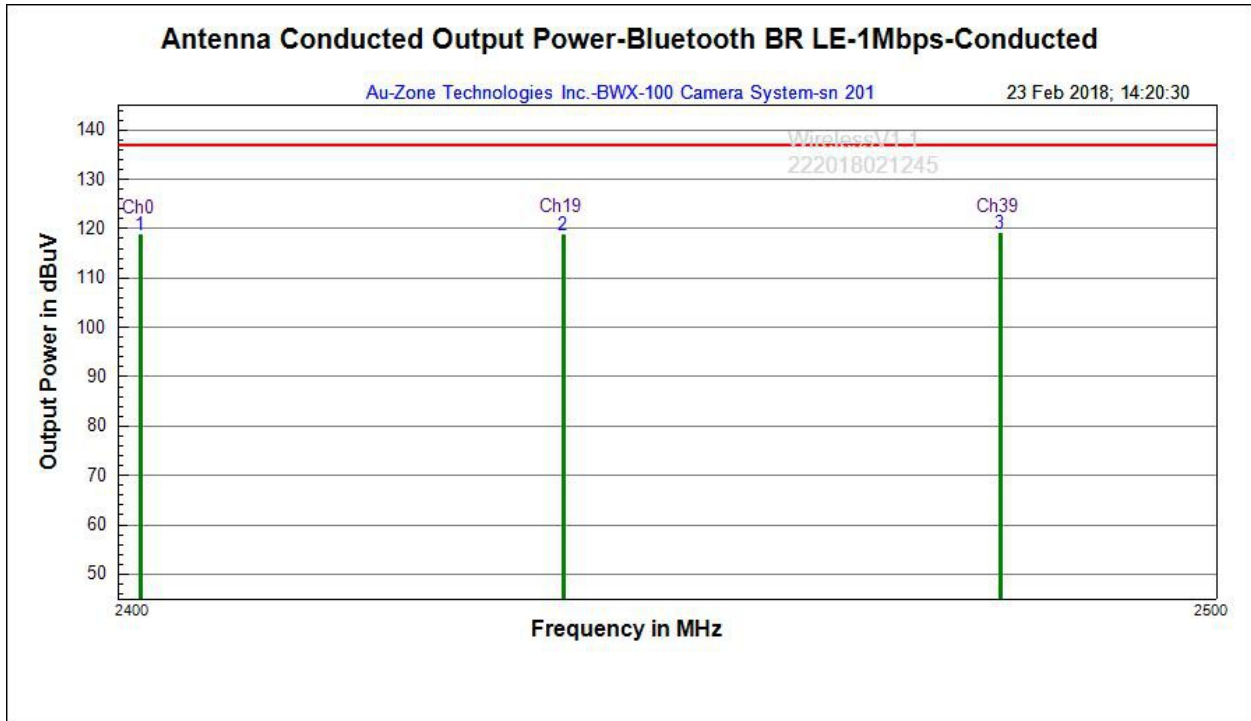

Figure 6.4 - Conducted Output Power (2400MHz - 2500MHz)

Table 6.4 – Conducted Output Power measurement

Frequency (MHz)	Measured Reading (dBuV)	Correction Factor (dB)	Corrected Reading (dBuV)	FCC 15.247(d) Limit (dBuV)	Margin (dB)
2402	108.54	10.2	118.74	137.00	-18.26
2440	108.67	10.2	118.87	137.00	-18.13
2480	108.80	10.2	119.00	137.00	-18.00

**6.2 FCC 15.247(d) RF Antenna Conducted Band Edge and Spurious Emissions** **Applicable****Table 6.5 - Conducted Emission information (FCC 15.247(d))**

CLIENT:	L3 Mobile-Vision Inc.	TEST STANDARD:	FCC 15.247(d)
MODEL NUMBER:	BWX-100 Camera System	PRODUCT:	Body Camera + Dock
SERIAL NUMBER:	Camera:214, Dock:307	CLASS:	FCC 15.247
TEMPERATURE:	20.5°C	HUMIDITY:	14%
TESTED BY:	Taekyun Kim	DATE OF TEST:	2018-02-17
TESTREFERENCE:	ANSI C63.10(2013), KDB 558074(April 5, 2017)		
TEST VOLTAGE:	3.85VDC		
SETUP:	<p>The EUT is DC powered through a DC power supply.</p> <p>The EUT is continuously transmitting. Low, Mid and High channels as well as all data rates were investigated, worst case data reported. The EUT was fitted with a temporary antenna port for direct conducted measurements.</p>		
FREQUENCY RANGE	Fundamental		
FREQUENCY TESTED:	2402MHz, 2440MHz, 2480MHz		
FIRMWARE POWER SETTING	Max power		
EUT FIRMWARE	1.5.95		
MODULATION/DATA RATE	All data rates were investigated, 1Mbps data rate was found to be worst case.		
ANTENNA TYPE/GAIN	Antenna 1(Chip antenna type, 1.6dBi)		
DUTY CYCLE	100%		
RESULTS:	PASS		

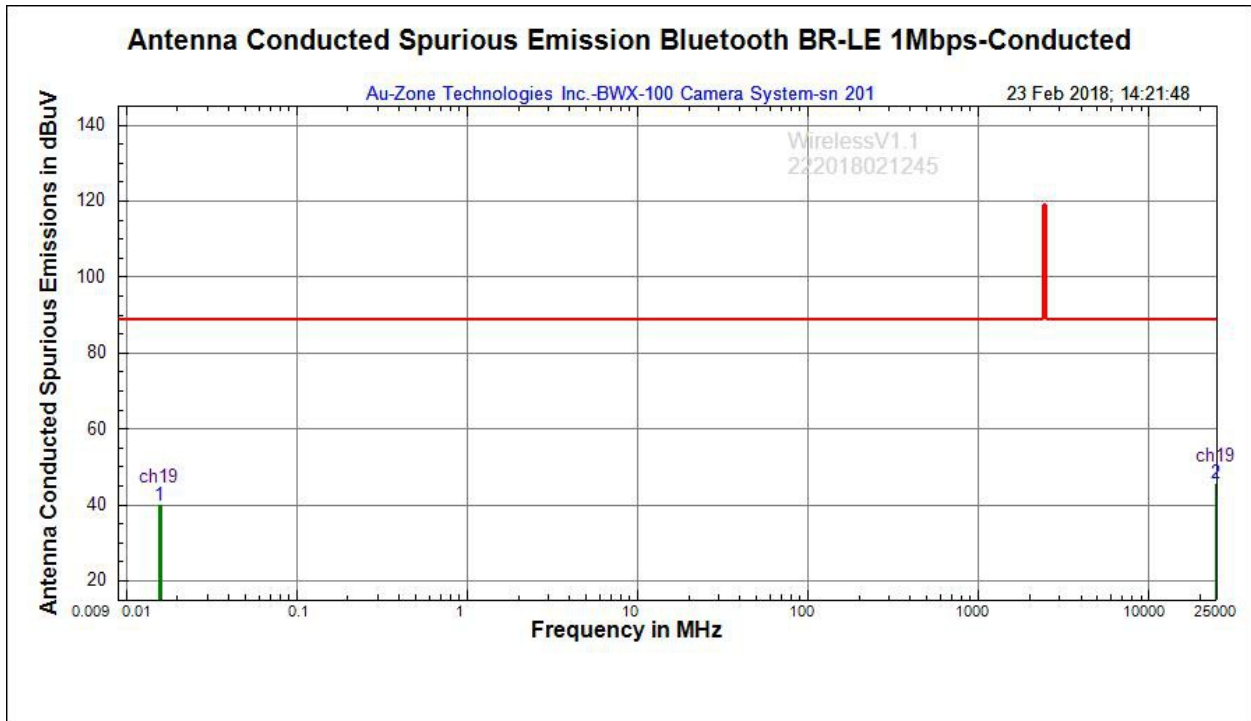

Figure 6.5 - Conducted Spurious Emission(9kHz - 25GHz)

[NOTE] There are no emissions detected above noise floor. The noise floor level is shown in the above chart

Table 6.6 -Conducted Spurious Emission measurement information (FCC 15.247(d))

Frequency (MHz)	Measured Reading (dBuV)	Correction Factor (dB)	Corrected Reading (dBuV/m)	FCC 15.247(d) Limit (dBuV/m)	Margin (dB)
0.0158	29.75	10.2	39.95	88.61	-48.66
24954.7486	35.49	10.2	45.69	88.61	-42.92



Table 6.7 – Band Edge information (FCC 15.247(d))

Frequency (MHz)	Modulation	Measured (dBc)	Limit (dBc)	Result
2390	1Mbps Data rate	-54.75	<-30	PASS
2400	1Mbps Data rate	-58.23	<-30	PASS
2483.5	1Mbps Data rate	-57.43	<-30	PASS

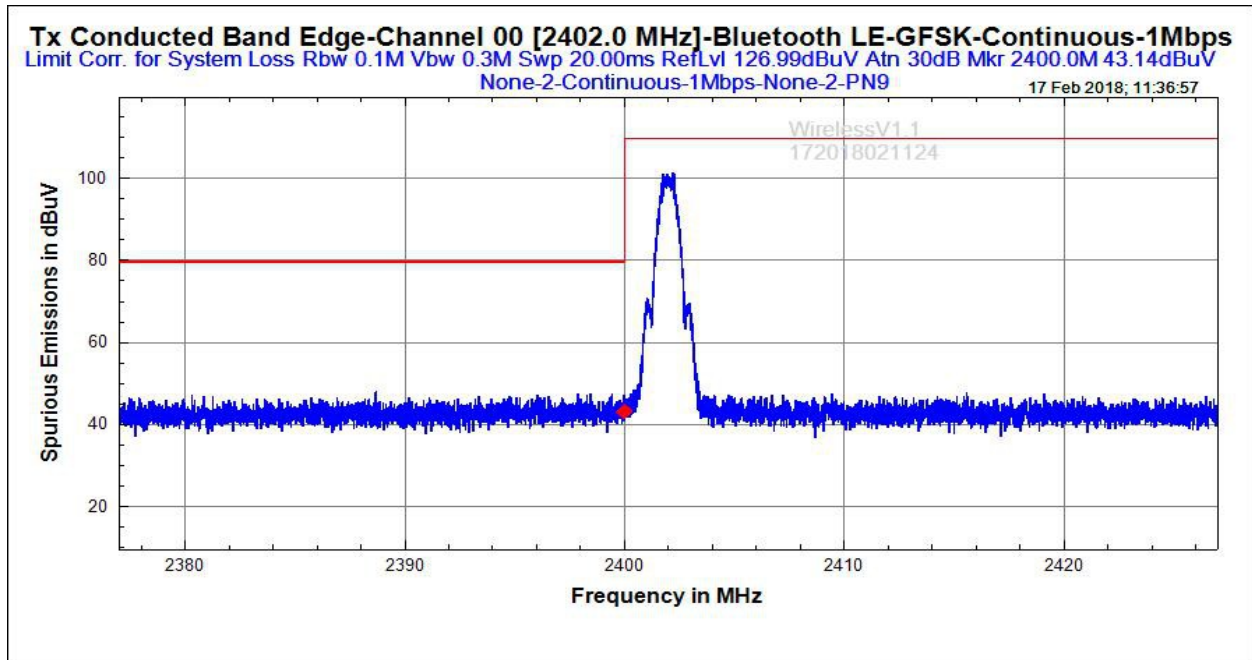

Figure 6.6 – Conducted Spurious Emissions(FCC Part 15,247(d))

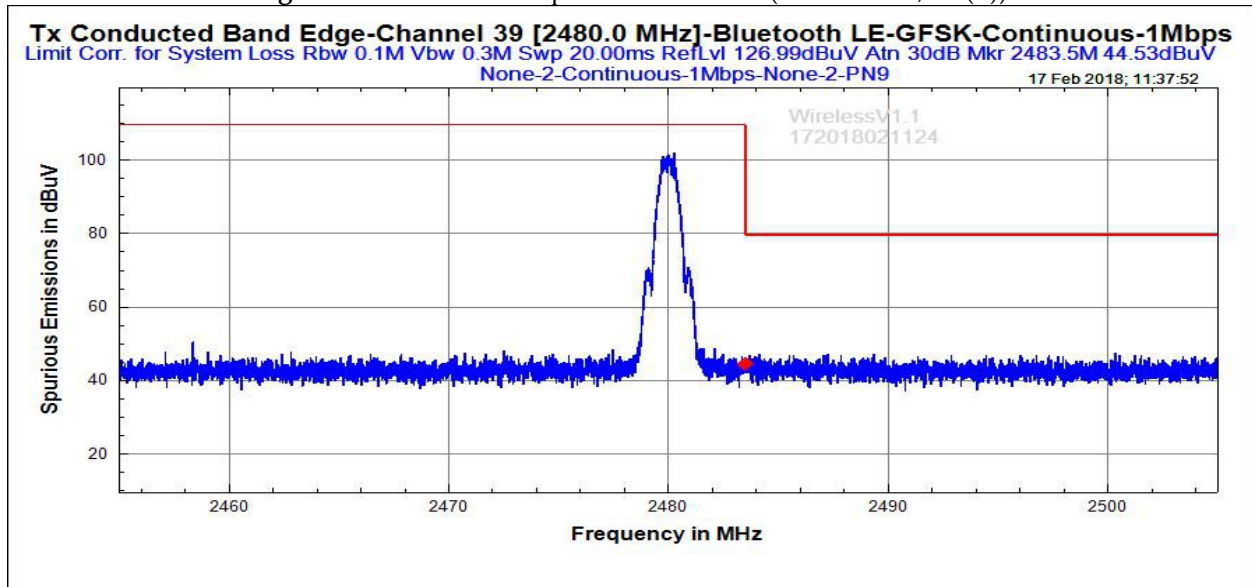

Figure 6.7 - Conducted Spurious Emissions(FCC Part 15,247(d))



Table 6.8 - Conducted Spurious Emission information (FCC 15.247(d))

CLIENT:	L3 Mobile-Vision Inc.	TEST STANDARD:	FCC 15.247(d)
MODEL NUMBER:	BWX-100 Camera System	PRODUCT:	Body Camera + Dock
SERIAL NUMBER:	Camera:214, Dock:307	CLASS:	FCC 15.247
TEMPERATURE:	20.5°C	HUMIDITY:	14%
TESTED BY:	Taekyun Kim	DATE OF TEST:	2018-02-16
TEST VOLTAGE:	3.85VDC		
SETUP:	<p>The EUT is DC powered through a DC power supply.</p> <p>The EUT is continuously transmitting. Low and High channels as well as all data rates were investigated, worst case data reported. The EUT was fitted with a temporary antenna port for direct conducted measurements.</p>		
FREQUENCY RANGE	Fundamental		
FREQUENCY TESTED:	2402MHz, 2480MHz		
FIRMWARE POWER SETTING	Max power		
EUT FIRMWARE	1.5.95		
MODULATION/DATA RATE	All data rates were investigated, 1Mbps data rate was found to be worst case.		
ANTENNA TYPE/GAIN	Antenna 1(Chip antenna type, 1.6dBi)		
DUTY CYCLE	100%		
RESULTS:	PASS		

Table 6.9 - Conducted Spurious Emission measurement

Frequency (MHz)	Measured Reading (dBuV)	Correction Factor (dB)	Corrected Reading (dBuV)	FCC 15.247(d) Limit (dBuV)	Margin (dB)
2400	43.14	10.2	53.34	75.6	-32.46
2483.5	44.53	10.2	54.73	75.6	-31.07

**6.3 FCC 15. 247(d) Tx Radiated Spurious Emission & Band Edge** **Applicable****Table 6.10 - Radiated Spurious Emission information (FCC 15.247(d)/15.209)**

CLIENT:	L3 Mobile-Vision Inc.	TEST STANDARD:	FCC 15.247(d)/ 15.209
MODEL NUMBER:	BWX-100 Camera System	PRODUCT:	Body Camera + Dock
SERIAL NUMBER:	Camera:214, Dock:307	CLASS:	FCC 15.247
TEMPERATURE:	23.5°C	HUMIDITY:	20%
TESTED BY:	Jaeheon Yun	DATE OF TEST:	2018-02-23
TESTREFERENCE:	ANSI C63.10(2013), KDB 558074(April 5, 2017)		
TEST VOLTAGE:	13.2VDC		
SETUP:	The EUT is DC powered through AC/DC adapter. The EUT is continuously transmitting. Low, Mid and High channels as well as all data rates were investigated, worst case data was reported. The EUT is fully exercised with communication and data transfer between the EUT and support laptop. Below 1GHz, the EUT is on the test table 80cm high. Above 1GHz, the EUT is on the test table 150cm high connected to the internal trace antenna.		
FREQUENCY RANGE	9k - 26GHz		
FREQUENCY TESTED:	2412MHz, 2437MHz, 2462MHz		
FIRMWARE POWER SETTING	Max power		
EUT FIRMWARE	1.5.95		
MODULATION/DATA RATE	All data rates were investigated, 1Mbps data rate was found to be worst case.		
ANTENNA TYPE/GAIN	Antenna 1(Chip antenna type, 1.6dBi)		
DUTY CYCLE	100%		
RESULTS:	PASS		

**Table 6.11 - Radiated Emission - Horizontal Polarization AVG**

Frequency (MHz)	Azimuth Angle (deg)	Antenna Height (cm)	Measured Reading (dBuV)	Correction Factor (dB)	Corrected Reading (dBuV/m)	FCC 15. 209 Limit (dBuV/m)	Margin (dB)
1249.99	306.6	248.7	47.43	-26.82	20.61	53.98	-33.37
1375	301.7	160.8	47.76	-26.56	21.20	53.98	-32.78
1499.99	232.4	287.4	51.97	-26.53	25.44	53.98	-28.54
2132.06	91.1	211.3	56.89	-22.07	34.82	53.98	-19.16
4960.47	314.8	213.9	53.27	-17.33	35.94	53.98	-18.04

Table 6.12 - Radiated Emission - Vertical Polarization AVG

Frequency (MHz)	Azimuth Angle (deg)	Antenna Height (cm)	Measured Reading (dBuV)	Correction Factor (dB)	Corrected Reading (dBuV/m)	FCC 15. 209 Limit (dBuV/m)	Margin (dB)
1249.99	0	150.1	49.99	-26.82	23.17	53.98	-30.81
1375	133.3	201.4	46.02	-26.56	19.46	53.98	-34.52
1499.99	64.6	111.3	52.33	-26.53	25.80	53.98	-28.18
2132.06	105	230	54.65	-22.07	32.58	53.98	-21.40
4960.47	300	151.5	50.46	-17.33	33.13	53.98	-20.85

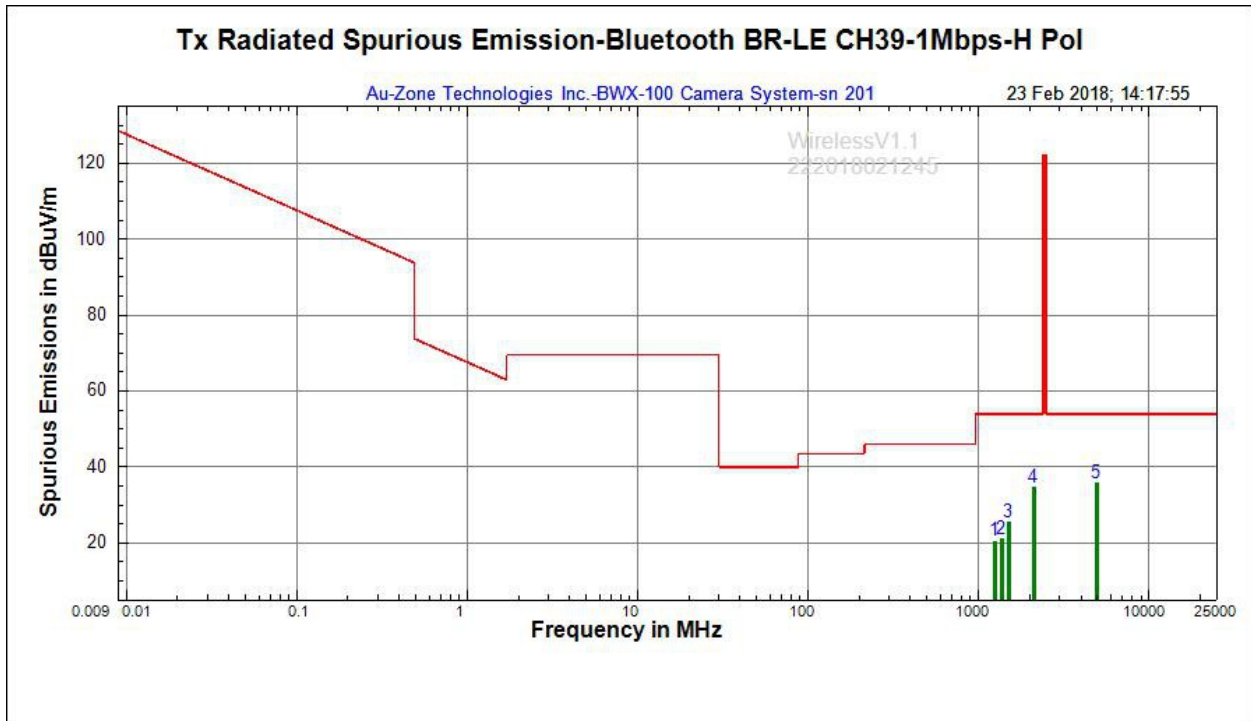

Figure 6.8 - Radiated Emission data(Ch 39, 1Mbps) -H-Pol

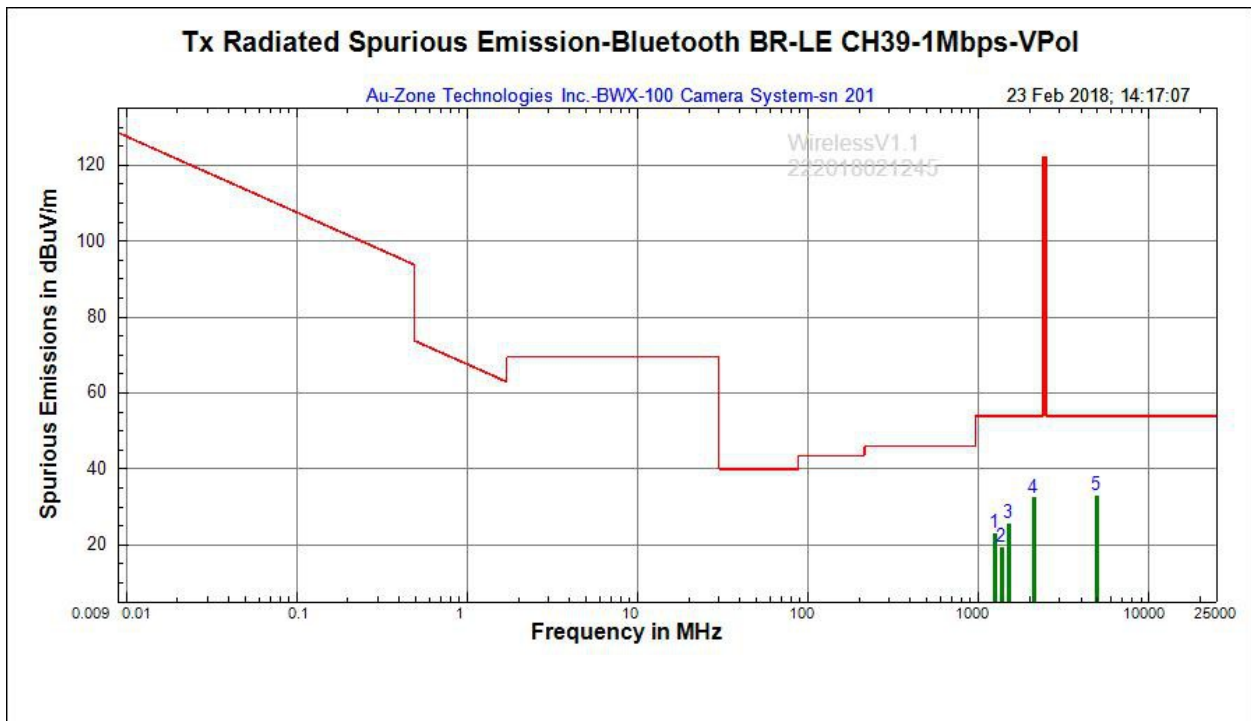

Figure 6.9 - Radiated Emission data(Ch 39, 1Mbps) – V-pol.

**Table 6.13a** – Band Edge information (FCC 15.247(d)) - 1Mbps data

Frequency (MHz)	Measurement (dBuV)	Factor (dB)	Field Strength (dBuV/m@ 3m)	Limit (dBuV/m @ 3m)	Margin (dB)	Detector	Result
2390	46.80	4.11	50.91	74	-23.09	Peak	PASS
2400	49.00	4.11	53.11	97.8	-44.69	Peak	PASS
2483.5	47.06	5.32	52.38	74	-21.62	Peak	PASS
2390	38.63	4.11	42.74	54	-11.26	AVG	PASS
2400	43.8	4.11	47.91	77.8	-29.89	AVG	PASS
2483.5	38.69	5.32	44.01	54	-9.99	AVG	PASS

[NOTE] All data rates were investigated, worst case data (1Mbps) was reported.

Table 6.13b – Band Edge information (FCC 15.247(d)) - 1Mbps data

Frequency (MHz)	Measurement (dBuV)	Channel Peak Level (dBuV)	Band Edge Level (dBc)	Limit (dBc)	Margin (dB)	Detector	Result
2390	46.80	90.74	-43.94	-30	-13.94	Peak	PASS
2400	49.00	90.74	-41.74	-30	-11.74	Peak	PASS
2483.5	47.06	90.74	-43.68	-30	-13.68	Peak	PASS
2390	38.63	90.74	-52.11	-30	-22.11	AVG	PASS
2400	43.8	90.74	-46.94	-30	-16.94	AVG	PASS
2483.5	38.69	90.74	-52.05	-30	-22.05	AVG	PASS

[NOTE] All data rates were investigated, worst case data (1Mbps) was reported.



Applicable

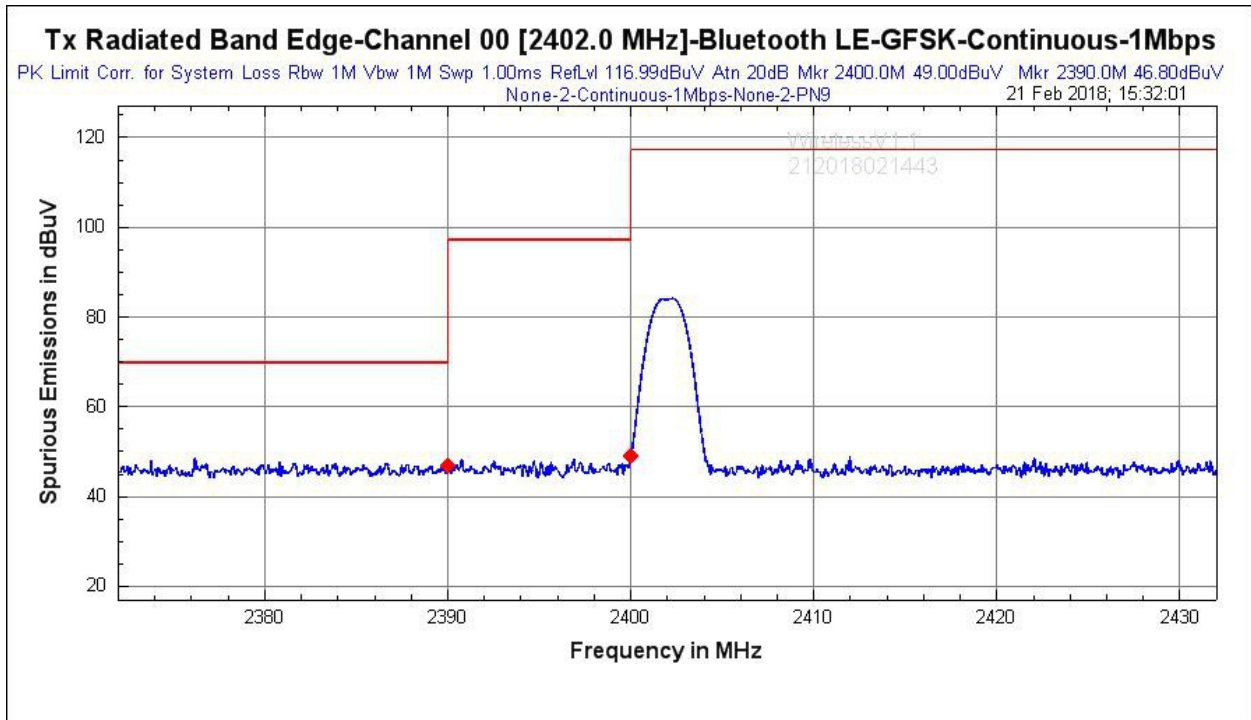

Figure 6.10 – Band edge data (Channel 0, 1Mbps, Peak)

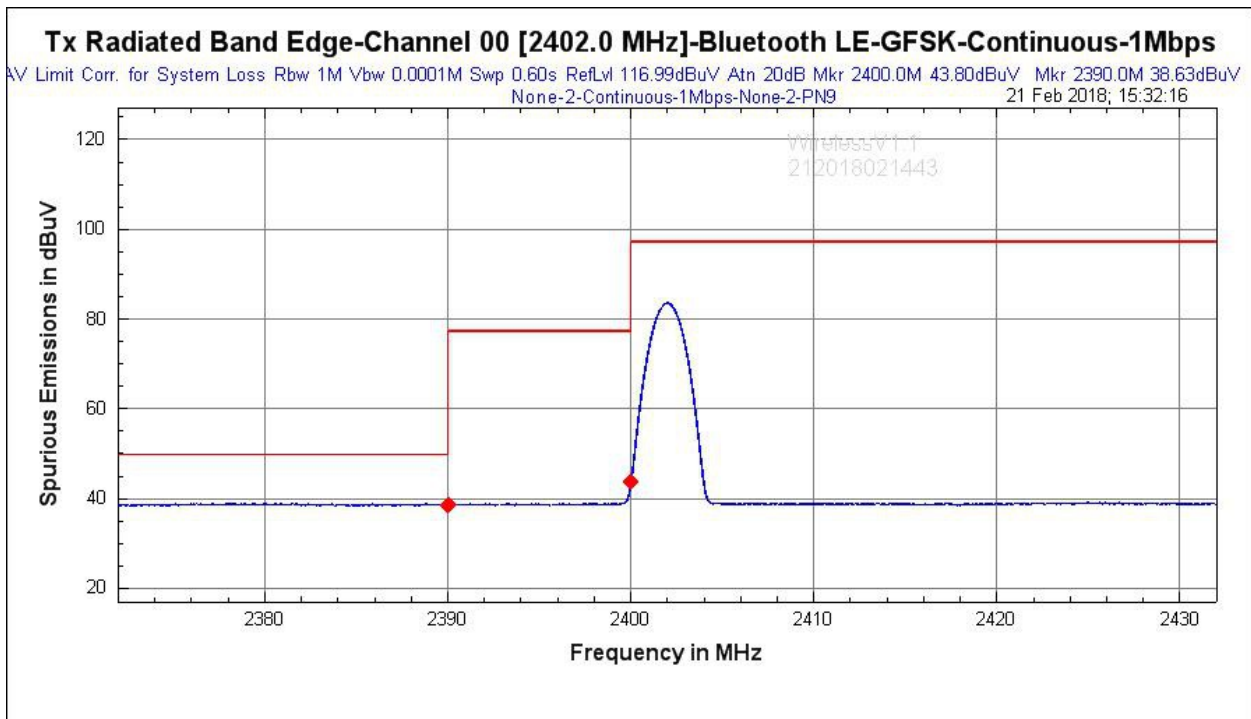

Figure 6.11 - Band edge data (Channel 0, 1Mbps, Average)



Applicable

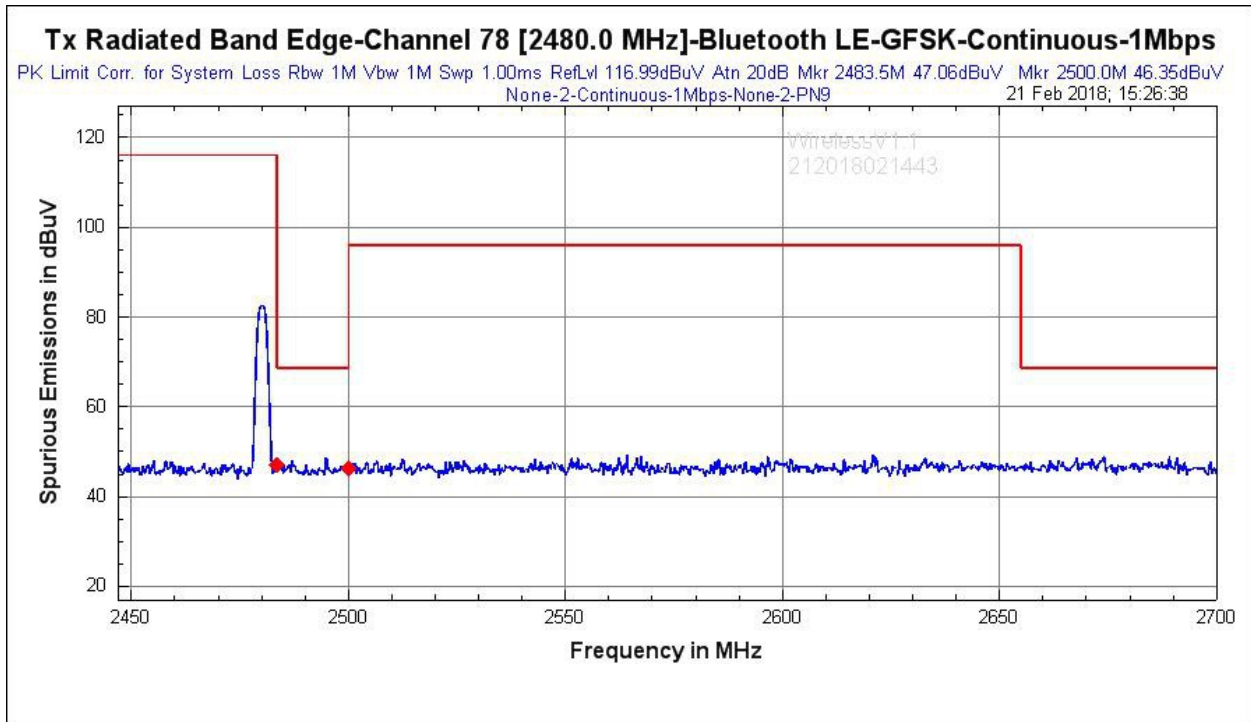

Figure 6.12 – Band edge data (Channel 78, 1Mbps, Peak)

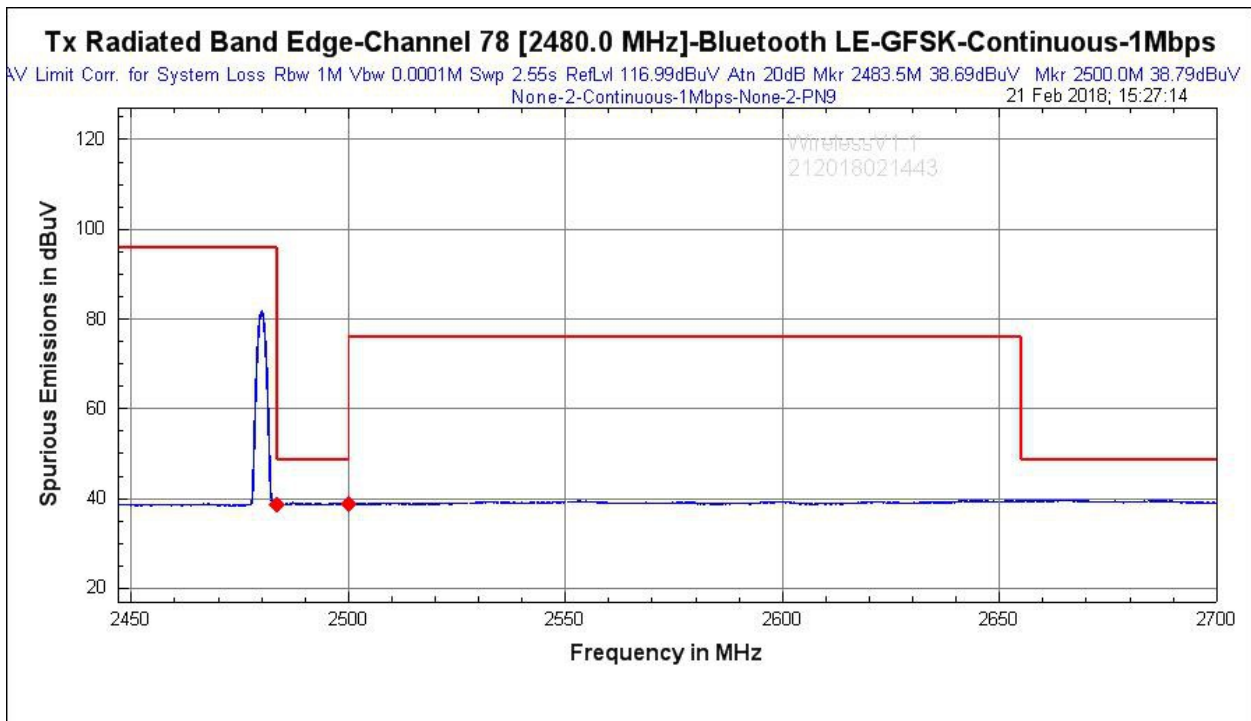

Figure 6.13 - Band edge data (Channel 78, 1Mbps, Average)

 Applicable**Table 6.14** - Radiated Spurious Emissions AVG(FCC 15.247(d)/15.209)

CLIENT:	L3 Mobile-Vision Inc.	TEST STANDARD:	FCC 15.247(d)/ 15.209
MODEL NUMBER:	BWX-100 Camera System	PRODUCT:	Body Camera + Dock
SERIAL NUMBER:	Camera:214, Dock:307	CLASS:	FCC 15.247
TEMPERATURE:	23.5°C	HUMIDITY:	20%
TESTED BY:	Taekyun Kim	DATE OF TEST:	2018-02-22
TESTREFERENCE:	ANSI C63.10(2013), KDB 558074(April 5, 2017)		
TEST VOLTAGE:	3.85VDC		
SETUP:	The EUT is DC powered through AC/DC adapter. The EUT is continuously transmitting. Low, Mid and High channels as well as all data rates were investigated, worst case data was reported. The EUT is fully exercised with communication and data transfer between the EUT and support laptop. Below 1GHz, the EUT is on the test table 80cm high. Above 1GHz, the EUT is on the test table 150cm high connected to the internal trace antenna.		
FREQUENCY RANGE	2.38GHz – 2.7GHz		
FREQUENCY TESTED:	2412MHz, 2462MHz		
FIRMWARE POWER SETTING	Max Power		
EUT FIRMWARE	1.5.95		
MODULATION/DATA RATE	All data rates were investigated, 1Mbps data rate was found to be worst case.		
ANTENNA TYPE/GAIN	Antenna 1(Chip antenna type, 1.6dBi)		
DUTY CYCLE	100%		
RESULTS:	PASS		



Table 6.15 - Radiated Emission - Horizontal Polarization AVG FCC

Frequency (MHz)	Azimuth Angle (deg)	Antenna Height (cm)	Measured Reading (dBuV)	Correction Factor (dB)	Corrected Reading (dBuV/m)	FCC 15. 209 Limit (dBuV/m)	Margin (dB)
2483.5	71.9	287.9	38.69	5.32	44.01	54	-9.99

Table 6.16 - Radiated Emission - Vertical Polarization AVG FCC

Frequency (MHz)	Azimuth Angle (deg)	Antenna Height (cm)	Measured Reading (dBuV)	Correction Factor (dB)	Corrected Reading (dBuV/m)	FCC 15. 209 Limit (dBuV/m)	Margin (dB)
2400	316.4	154.5	43.8	4.11	47.91	77.8	-29.89

**6.4 FCC 15.107 AC Conducted Emission Measurement** **Applicable****Table 6.17 – AC Conducted Emission information**

CLIENT:	L3 Mobile-Vision Inc.	TEST STANDARD:	FCC 15.107
MODEL NUMBER:	BWX-100 Camera System	PRODUCT:	Body Camera + Dock
SERIAL NUMBER:	Camera:214, Dock:307	CLASS:	Class B
TEMPERATURE:	22.5°C	HUMIDITY:	21%
TESTED BY:	Taekyun Kim	DATE OF TEST:	January 07, 2018
TEST REFERENCE:	ANSI C63.10(2013), FCC 15.107		
TESTED RANGE:	0.15MHz - 30MHz		
TEST VOLTAGE:	120VAC 60Hz AC/DC adapter used 3.85VDC		
TEST SETUP:	The EUT is DC powered through a USB AC/DC power Adapter. The USB AV/DC power adapter connected to LISN. The EUT performed 10/100Mbps Download.		
RESULTS:	PASS		



Table 6.18 - Conducted Emission Line 1 – AVG FCC

Emission Type	Frequency (MHz)	Measured Reading (dBuV)	Correction Factor (dB)	Corrected Reading (dBuV)	FCC AVG Limit (dBuV)	FCC Margin (dB)
Conducted Emission	0.209	39.1	10.21	49.31	54.29	-4.98
	0.419	25.95	10.18	36.13	48.32	-12.19
	0.539	28.08	10.18	38.26	46	-7.74
	1.799	20.38	10.21	30.59	46	-15.41
	2.095	24.76	10.22	34.98	46	-11.02
	4.395	24.58	10.26	34.84	46	-11.16
	7.141	23.51	10.29	33.8	50	-16.2

Table 6.19 - Conducted Emission Line 2 – AVG FCC

Emission Type	Frequency (MHz)	Measured Reading (dBuV)	Correction Factor (dB)	Corrected Reading (dBuV)	FCC AVG Limit (dBuV)	FCC Margin (dB)
Conducted Emission	0.209	39.46	10.21	49.67	54.29	-4.62
	0.419	24	10.18	34.18	48.32	-14.14
	0.539	26.71	10.18	36.89	46	-9.11
	1.799	24.86	10.21	35.07	46	-10.93
	2.095	20.63	10.22	30.85	46	-15.15
	4.395	20.22	10.26	30.48	46	-15.52
	7.141	22.48	10.29	32.77	50	-17.23



Applicable

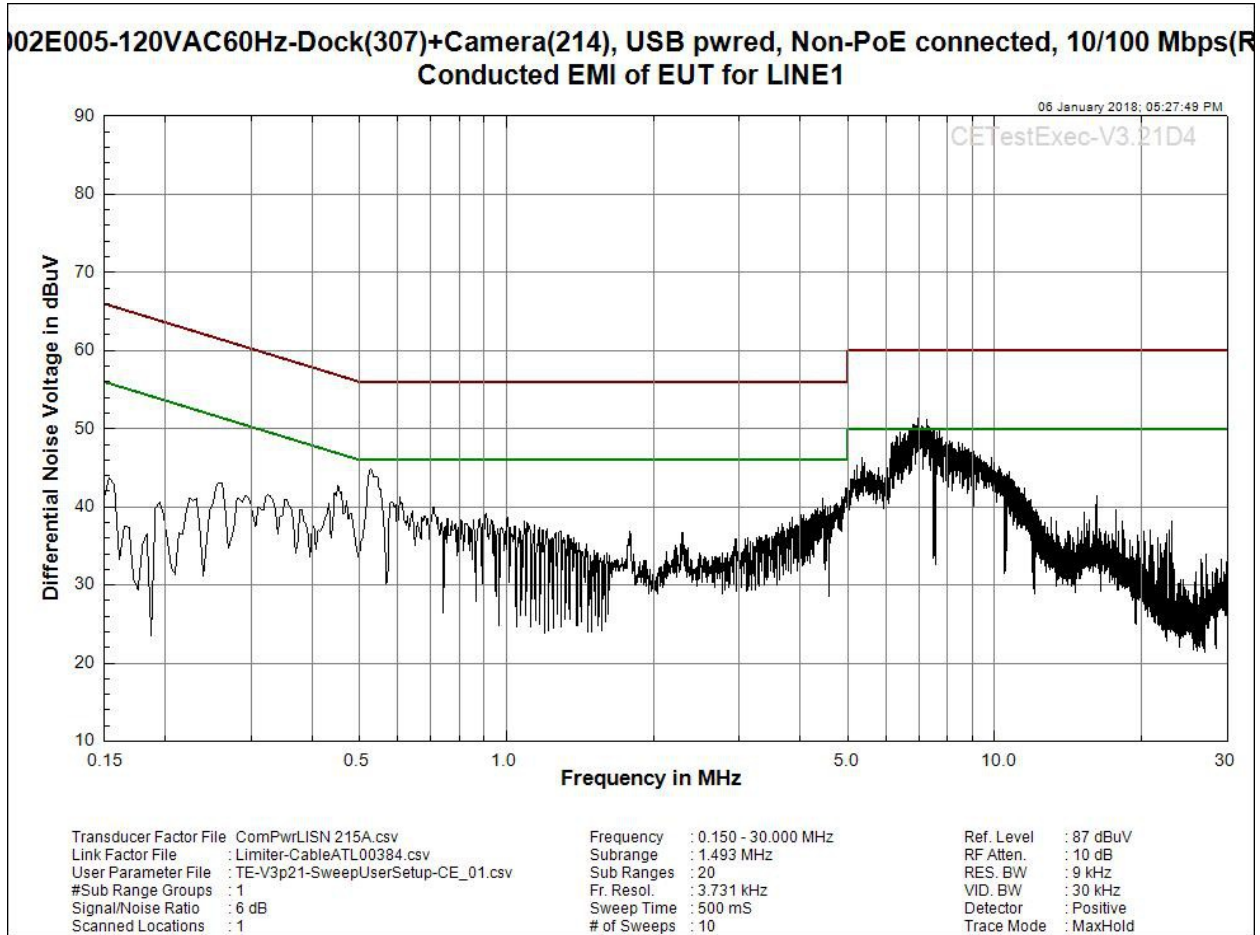

Figure 6.14 - Conducted Emission Scan Line 1 (Line L)

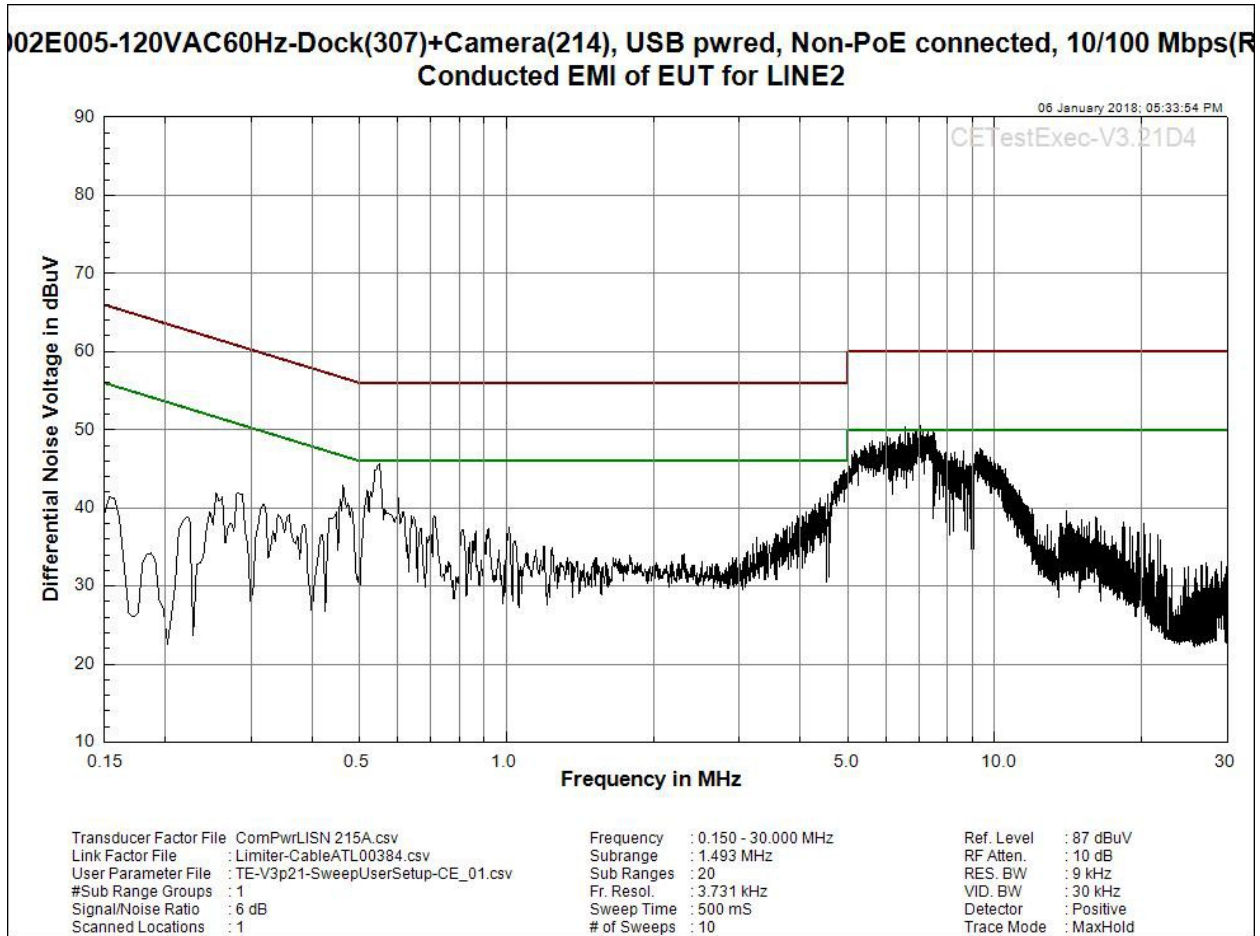

Figure 6.15 - Conducted Emission Scan Line 2 (Line N)

**Table 6.20 – AC Conducted Emission information**

CLIENT:	L3 Mobile-Vision Inc.	TEST STANDARD:	FCC 15.107
MODEL NUMBER:	BWX-100 Camera System	PRODUCT:	Body Camera + Dock
SERIAL NUMBER:	Camera:214, Dock:307	CLASS:	Class B
TEMPERATURE:	22.5°C	HUMIDITY:	21%
TESTED BY:	Taekyun Kim	DATE OF TEST:	January 07, 2018
TEST REFERENCE:	ANSI C63.10(2013), FCC 15.107		
TESTED RANGE:	0.15MHz - 30MHz		
TEST VOLTAGE:	120VAC 60Hz AC/DC adapter used 3.85VDC		
TEST SETUP:	The EUT is DC powered through a USB AC/DC power Adapter. The USB AV/DC power adapter connected to LISN. The EUT performed 1Gbps Download.		
RESULTS:	PASS		



Table 6.21 - Conducted Emission Line 1 – AVG FCC

Emission Type	Frequency (MHz)	Measured Reading (dBuV)	Correction Factor (dB)	Corrected Reading (dBuV)	FCC AVG Limit (dBuV)	FCC Margin (dB)
Conducted Emission	0.209	35.11	10.21	45.32	54.29	-8.97
	1.799	19.63	10.21	29.84	46	-16.16

Table 6.22 - Conducted Emission Line 2 – AVG FCC

Emission Type	Frequency (MHz)	Measured Reading (dBuV)	Correction Factor (dB)	Corrected Reading (dBuV)	FCC AVG Limit (dBuV)	FCC Margin (dB)
Conducted Emission	0.209	34.20	10.21	44.4	54.29	-9.89
	1.799	19.51	10.21	29.72	46	-16.28



Applicable

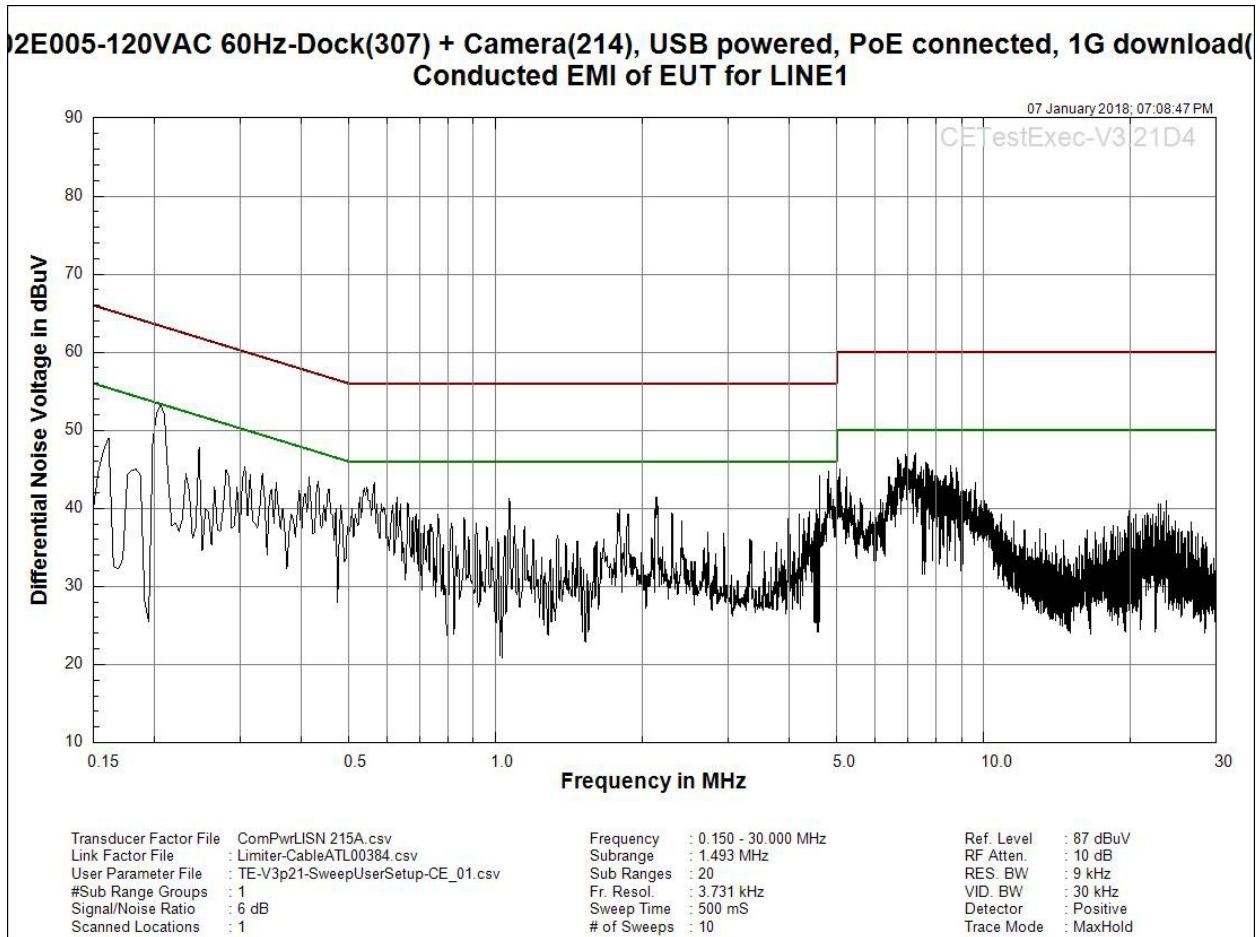

Figure 6.16 - Conducted Emission Scan Line 1 (Line L)

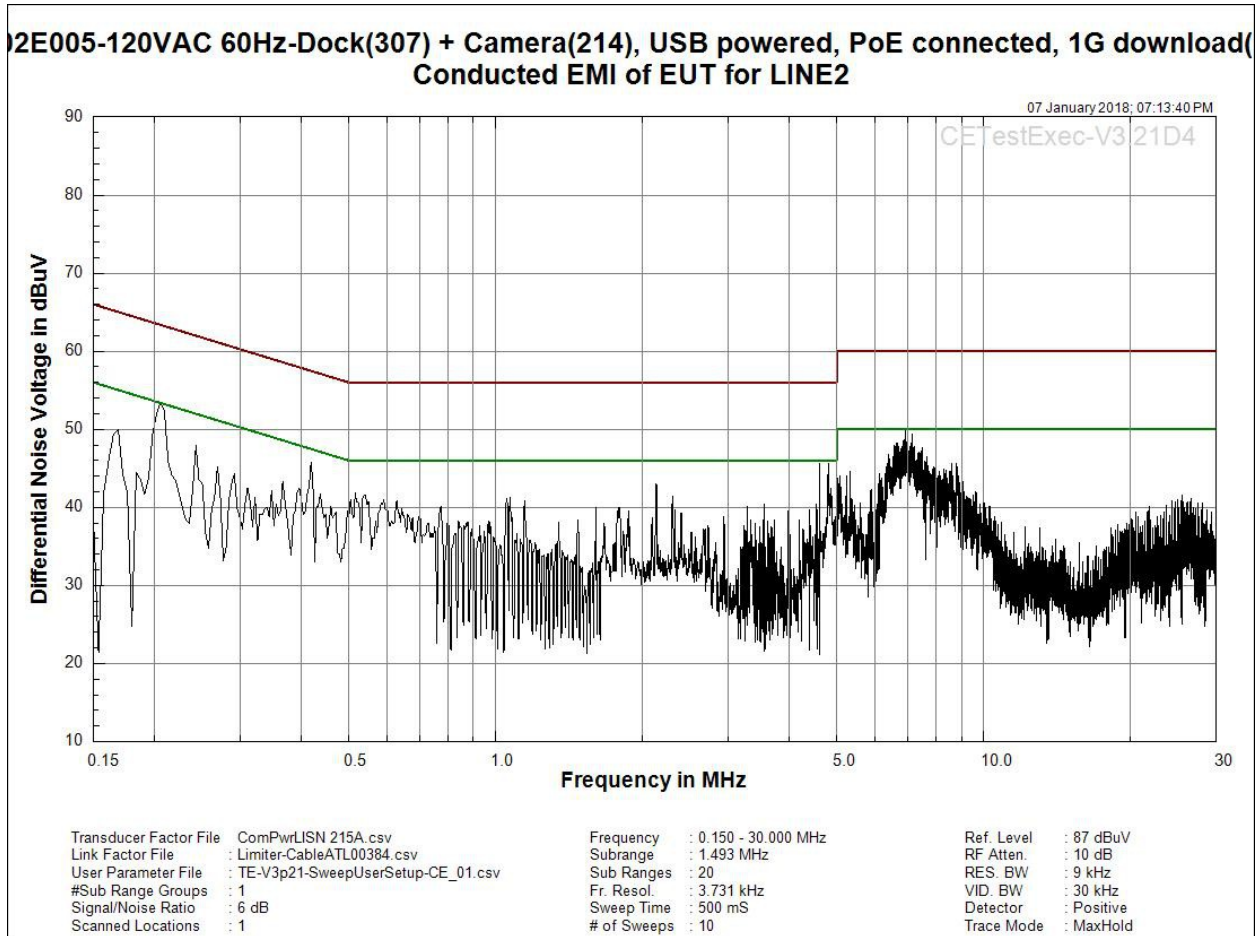

Figure 6.17 - Conducted Emission Scan Line 2 (Line N)



6.5 FCC15.109 Radiated Emission(30MHz - 1000MHz)

Several pre-scans may have been performed in an effort to mitigate any non-compliance and ultimately to identify the six highest offending Emission. The final compliance scan graph is shown below in figure 6.18 to figure 6.19.

Applicable

Table 6.23 - Radiated Emission information (FCC)

CLIENT:	L3 Mobile-Vision Inc.	TEST STANDARD:	FCC 15.109
MODEL NUMBER:	BWX-100 Camera System	PRODUCT:	Body Camera + Dock
SERIAL NUMBER:	Camera:214, Dock:307	CLASS:	FCC 15.247
TEMPERATURE:	22°C	HUMIDITY:	22%
TESTED BY:	Taekyun Kim	DATE OF TEST:	2017-12-14
TESTREFERENCE:	FCC Part 15.109		
TESTED RANGE:	30MHz - 1000MHz		
TEST VOLTAGE:	120VAC 60Hz AC/DC adapter used 3.85VDC		
RESULTS:	PASS		
CHANGES OR MODIFICATIONS:	N/A		

**Table 6.24 - Radiated Emission - Horizontal Polarization Quasi-peak FCC**

Frequency (MHz)	Azimuth Angle (deg)	Antenna Height (cm)	Measured Reading (dBuV)	Correction Factor (dB)	Corrected Reading (dBuV/m)	FCC Limit (dBuV/m)	Margin (dB)
47.83	126	300	6.16	13.87	20.03	40	-19.97
73.66	180	400	6.93	13.68	20.61	40	-19.39
103.048	159.8	373.8	2.18	15.27	17.45	43.52	-26.07
374.99	125.8	200	4.69	23.36	28.05	46.06	28.05
500.02	88.9	162.4	12.16	26.67	38.83	46.02	-7.19
625	0	181.3	9.9	29.9	39.80	46.02	-6.22

Table 6.25 - Radiated Emission - Vertical Polarization Quasi-peak FCC

Frequency (MHz)	Azimuth Angle (deg)	Antenna Height (cm)	Measured Reading (dBuV)	Correction Factor (dB)	Corrected Reading (dBuV/m)	FCC Limit (dBuV/m)	Margin (dB)
47.83	135	100	23.73	13.87	37.60	40	-2.40
73.66	340	100	22.33	13.68	36.01	40	-3.99
103.048	135.3	100	18.29	15.27	33.56	43.52	-9.96
374.99	25.6	199.2	11.95	23.36	35.31	46.06	-10.75
500.02	67.4	100	17.2	26.67	43.87	46.02	-2.15
625	0	100	9.5	29.9	39.40	46.02	-6.62



Applicable

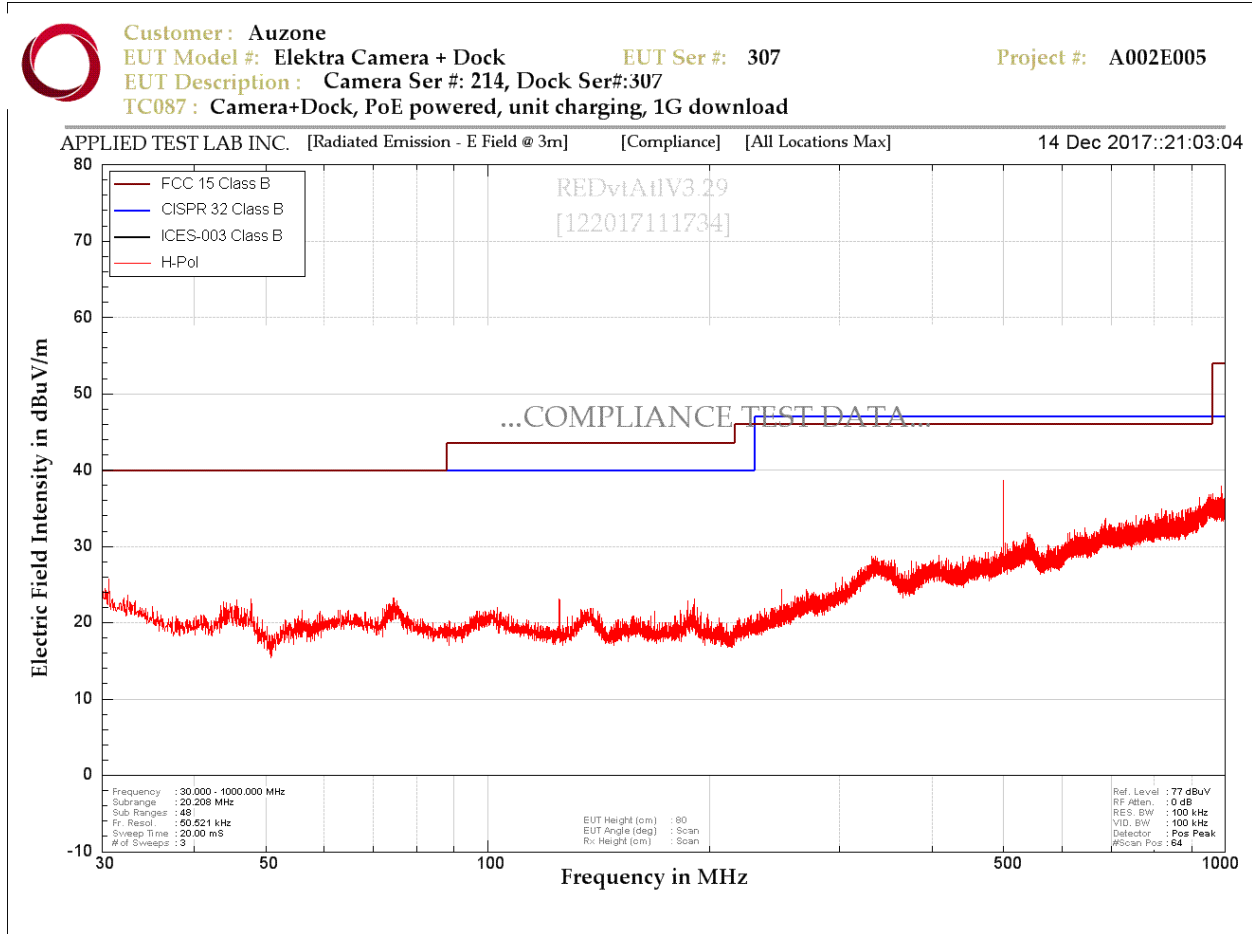

Figure 6.18 - Radiated Emission (FCC) - Scan Horizontal Polarization (30MHz - 1000MHz)

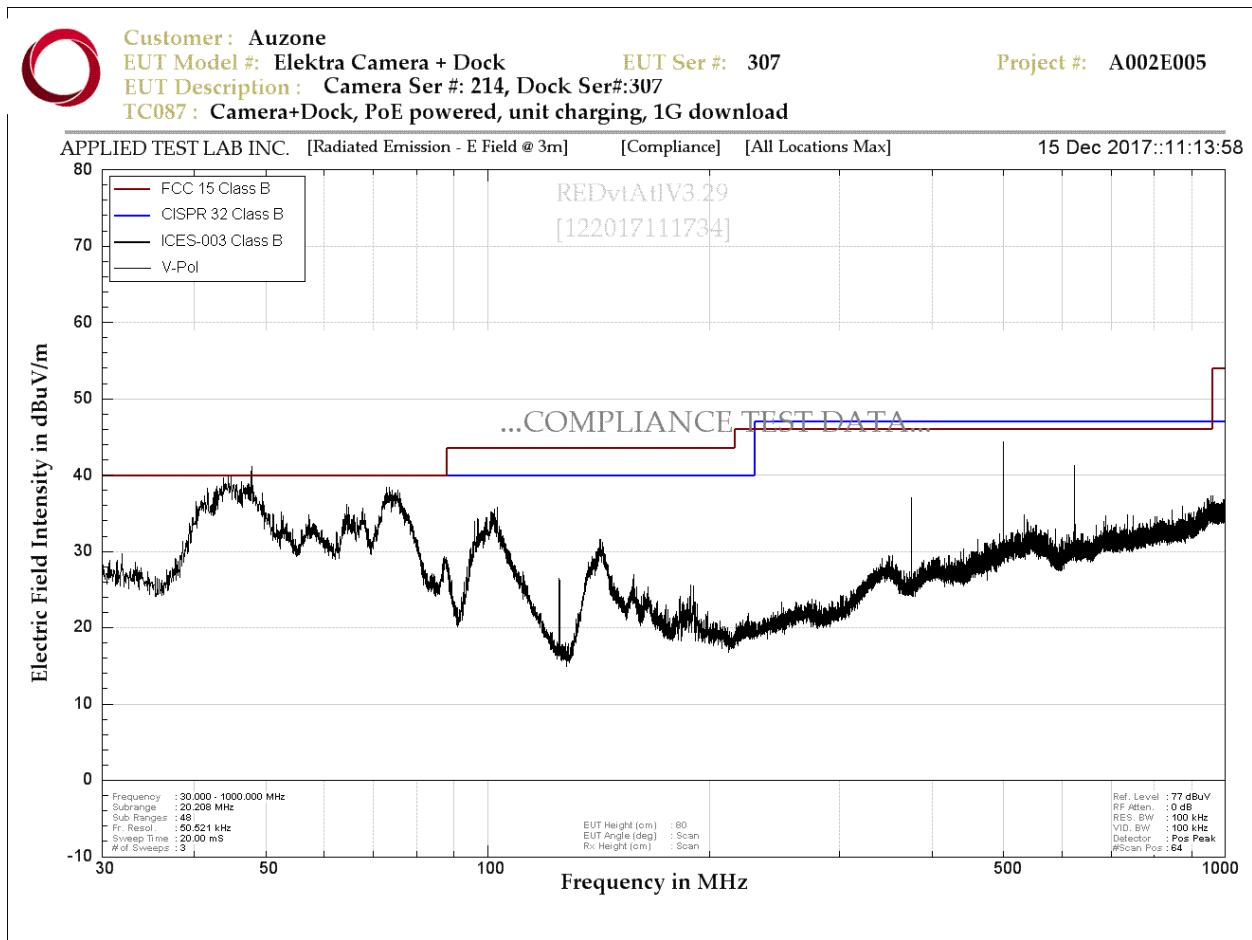

Figure 6.19 - Radiated Emission (FCC) - Scan Vertical Polarization (30MHz - 1000MHz)



6.6 FCC15.109 Radiated Emission(Above 1000MHz)

Applicable

Table 6.26 - Radiated Emission information (FCC)

CLIENT:	L3 Mobile-Vision Inc.	TEST STANDARD:	FCC 15.109
MODEL NUMBER:	BWX-100 Camera System	PRODUCT:	Body Camera + Dock
SERIAL NUMBER:	Camera:214, Dock:307	CLASS:	FCC 15.247
TEMPERATURE:	23.5°C	HUMIDITY:	24%
TESTED BY:	Taekyun Kim	DATE OF TEST:	2018-01-02
TESTREFERENCE:	FCC part 15.109		
TESTED RANGE:	1000MHz - 6000MHz		
TEST VOLTAGE:	120VAC 60Hz AC/DC adapter used 3.85VDC		
RESULTS:	PASS		
CHANGES OR MODIFICATIONS:	N/A		



Applicable

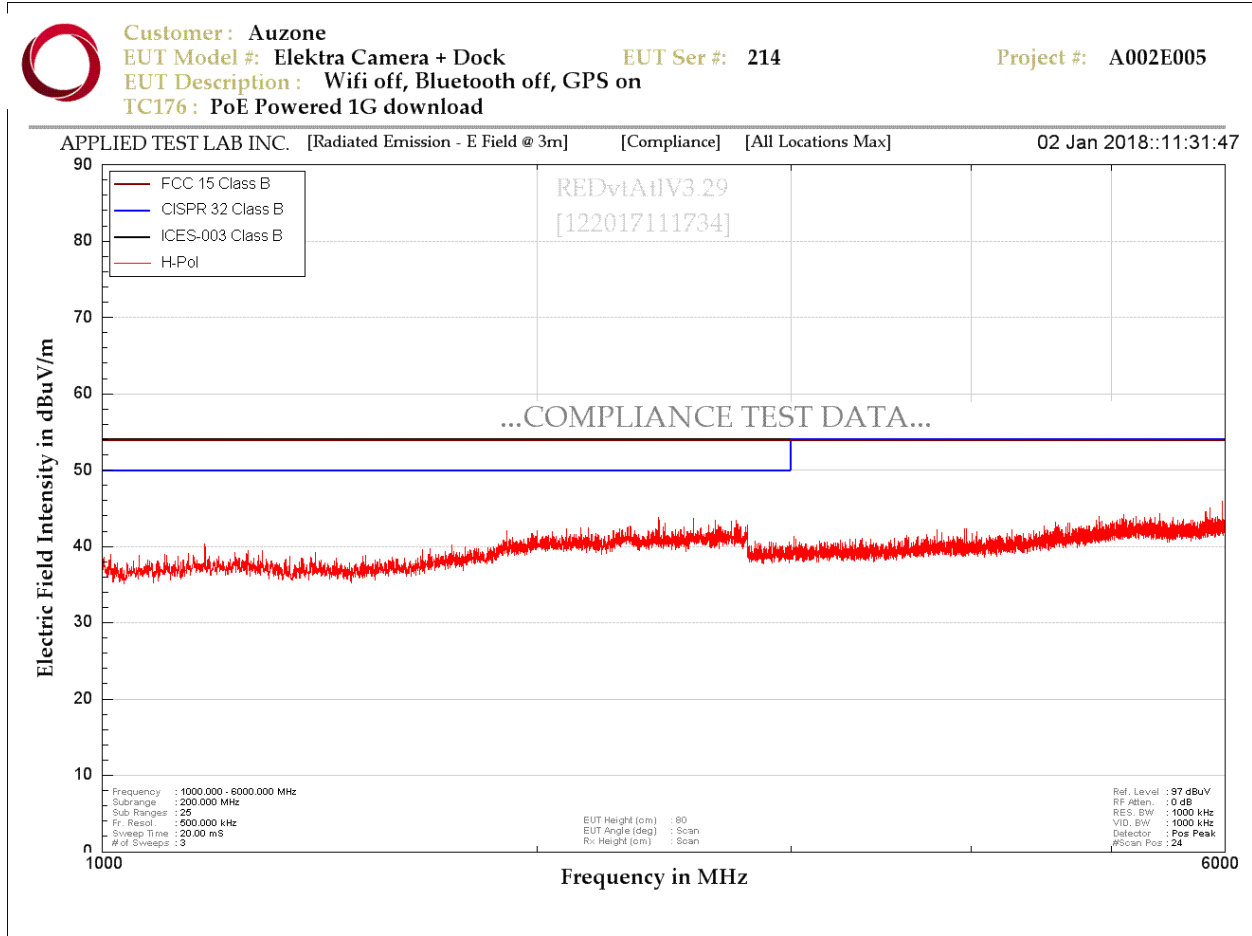

Figure 6.5 - Radiated Emission (FCC) - Scan Horizontal Polarization (1000MHz - 6000MHz)



Customer : Auzone

EUT Model #: Elektra Camera + Dock

EUT Ser #: 214

Project #: A002E005

EUT Description : Wifi off, Bluetooth off, GPS on

TC176 : PoE Powered 1G download

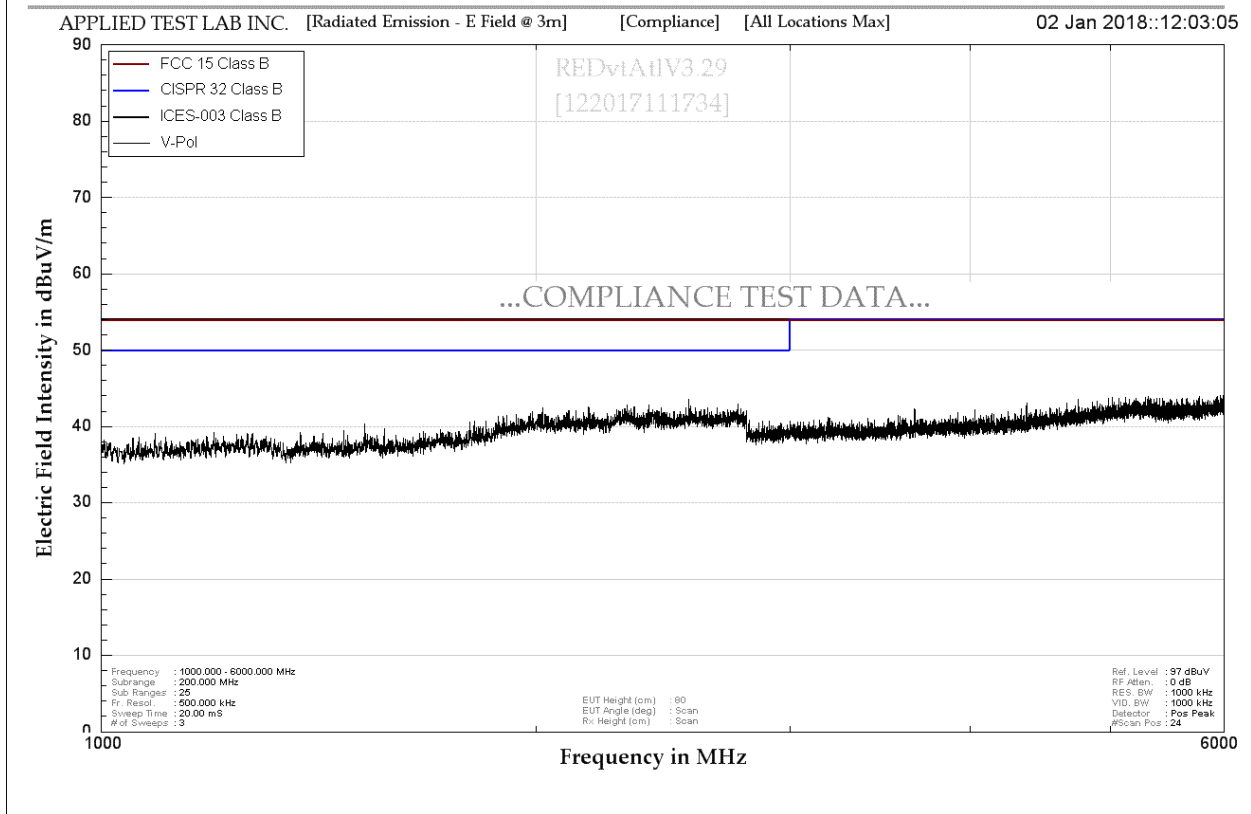

Figure 6.6 - Radiated Emission (FCC) - Scan Vertical Polarization (1000MHz - 6000MHz)



7.0 Appendix A – Test Sample Description

(From Data Provided by the Customer)

BWX-100 Camera System:

Camera:

BWX-100 is a small, body worn digital video recorder that can be used to capture high definition video with audio. After recording video, you can upload it to your Mobile-Vision video management software by simply placing the device in a docking station connected to the internet.

BWX-100 features include:

- 10.5 hours of video recording in full high definition (1920 x 1080)
- A 129° field of view
- Bi-directional record triggering between BWX-100 devices
- Mobile App for IOS and Android devices
- Built-in WiFi, Bluetooth, and GPS

Note: In Wi-Fi, the HT40 mode is not being used due to current software driver limitations and the required throughput of the camera.

With BWX-100, you can:

- Tag video in the field
- Review video in the field
- Check device status in the field, such as remaining record time and battery power.
- Capture a still photo “snapshot” while a recording is in progress
- Insert a “tracepoint” place marker while a recording is in progress
- Record in “Covert Mode”, which deactivates all electronic audio/visual indicators
- Mute audio while a recording is in progress
- Easily upload video to PC/Laptop via a docking station connected to the internet
- Capture up to 90 seconds of pre-record activity (i.e., the activity that occurs just before a user initiates a recording)

Docking Station:

The Docking Station includes a clip on the side that is used to link multiple devices together to form a Charging/Transmitting station

The Docking Station has three purposes:

- Upload videos from the BWX-100 to your PC/Laptop



- Download data from PC/laptop to BWX-100
- Recharge the BWX-100's battery using USB power or POE power.

Camera changes:

Camera changes before compliance test started

- R55 changed to 255 ohm

Dock changes:

Dock changes before Dec 14, 2017. Test done from Dec 14 will have the following dock changes

- Changes for USB power as default power
- Connection from Q4.3 to U5 current limiter EN pin (U5.4) removed.
- Q4.3 is connected to U6.4 (POE current limiter EN pin)
- Q4.1 is changed to VBUS_USB pullup from 5V_POE pullup.
- ESD diode added on U2 buffer output (U2.4 to GND)
- ESD diode added on U1 buffer output (U1.4 to GND)
- 475 ohm resistor added between RJ45 connector pin(J2.10) and buffer U2.4
- 475 ohm resistor added between via (via connected to green led D2 and green led on RJ45 connector and buffer U1.4)
- R26,R23 and R2 resistors removed and shorted.
- Snubber tuning circuit changes:
 - C10 to 680pF
 - C46 to 100pF
 - R44 to 66.5R

Cap changes:

- C17, C14 to 10nF
- C12 to 47nF
- C11 to 22nF
- R48 to 1k
- L2 – change back to Ferrite
- L1 – move L2 to L1.

The following changes are done on Dec 27. Test done from Dec 27 will have the following changes

- 0.1uF added between U5.10 (Fault) and GND



- 0.1uF added between U6.10(Fault) and GND
- 0.1uF added between U5.4(EN) and GND
- 0.1uF added between U6.4(EN) and GND
- R48 – changed to 4.2k from 1k
- and all changes done before Dec 27, 2017

The following changes are done on Jan 02. Test done from Jan02 will have the following changes in addition to Dec 27 changes

- R11 - changed to 15ohm from 10ohm
- Q3 changed to SI3440 from FDC86244.



8.0 Appendix B – List of Abbreviations and Acronyms

Industrial, scientific and medical (ISM) applications (of radio frequency energy)

operation of equipment or appliances designed to generate and use locally radio frequency energy for industrial, scientific, medical, domestic or similar purposes, excluding applications in the field of telecommunications

ISM equipment and appliances

equipment or appliances designed to generate and/or use locally radio-frequency energy for industrial, scientific, medical, domestic or similar purposes, excluding applications in the field of telecommunications and information technology and other applications covered by other CISPR publications

Electromagnetic radiation

1. phenomenon by which energy in the form of electromagnetic waves emanates from a source into space
2. energy transferred through space in the form of electromagnetic waves

Boundary of the equipment under test

imaginary straight line periphery describing a simple geometric configuration encompassing the equipment under test. All interconnecting cables are included within this boundary

Electro-discharge machining (EDM) equipment

all the necessary units for the spark erosion process including the machine tool, the generator, control circuits, the working fluid container and integral devices

Spark erosion

removal of material in a dielectric working fluid by electro-discharges, which are separated in time and randomly distributed in space, between two electrically conductive electrodes (the tool electrode and the work piece electrode), and where the energy in the discharge is controlled

Arc welding equipment

equipment for applying current and voltage and having the required characteristics suitable for arc welding and allied processes

Equipment for resistance welding and allied processes

all equipment associated with carrying out the processes of resistance welding or allied processes consisting of e.g. power source, electrodes, tooling and associated control equipment, which may be a separate unit or part of a complex machine

Low voltage LV

a set of voltage levels used for the distribution of electricity and whose upper limit is generally accepted to be 1 000 V a.c.



End of document