

## Mounting the Mobile Device

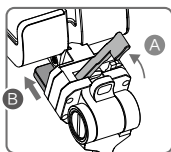

Ensure that Part B is unlocked. Connect Part B to Part A.

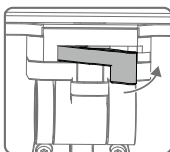

Lock the Mounting Bracket.

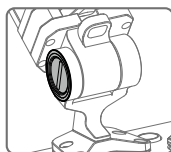

Use a coin or the screwdriver included to adjust the tightness of the tilt axis.

① Press the button to release the clamp.

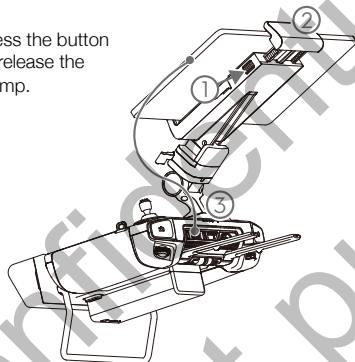

② Place your mobile device and adjust the clamp to secure.

③ Connect your mobile device with a USB cable.

## Attaching the Control Sticks

Follow the steps below to attach the control sticks to the remote controller.

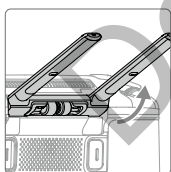

Lift the antennas

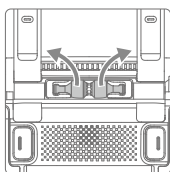

Remove the control sticks

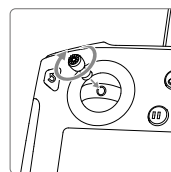

Rotate to attach the control sticks



The control sticks can be stored in the sticks storage slot on the back of the remote controller.

---

## Remote Controller Operations

### Checking the Battery Level and Turning On

#### Checking the Internal Battery Level

Check the internal battery level according to the Battery Level LEDs. Press the power button once to check it while turned off.

Press the power button once, press again and hold for a few seconds to turn on / off the Secure Controller.

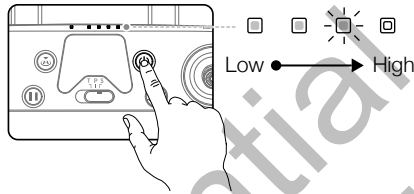

- 
- ⚠ • When using external RC Battery, it is still necessary to make sure that the internal battery has some power. Otherwise, the Secure Controller cannot be turned on.
- Once the remote control cannot be shut down normally, press and hold the power button for at least 8 seconds, the remote control will be forced to shut down.
- 

#### Checking the External Battery Level

Method 1: Press the button of the external battery, the battery level is presented in the form of LED lights.



Method 2: Check the percentage of the battery level in the status bar of the main page of the remote controller.

- 
- ⚠ When using an aircraft firmware version of v02.02.01.02 or later, it is not possible to take off when the battery level of the remote controller is below 10%.
- 

### Charging and Discharging Description

#### Charging

- The remote controller is not activated, the internal battery can only reach up to 60% battery level, and after activation, it can reach 100%.
- The internal battery of the remote controller currently supports charging by the standard charger and external battery (RC).
- When the external battery is used independently for charging, the internal battery can be charged up to 50%.
- When the working temperature is different, the charging speed varies.

---

## Discharging

- a. When the charger and external battery are connected at the same time, the charger supplies power to the remote controller.
- b. When only the external battery is connected, the external battery will supply power to the remote controller. However, once the external battery is exhausted, the internal battery will supply power.

## Linking

When the Secure Controller is purchased together with an aircraft, the remote controller has already been linked to the aircraft, and they can be directly used after activating the remote controller and aircraft. If the Secure Controller and the aircraft were purchased separately, follow the steps below to link the remote controller to the aircraft.

### Method 1: Using Secure Controller Buttons

1. Power on the remote controller and the aircraft.
2. Press the customizable button C1, C2, and Record button simultaneously. The status LED blinks blue and the controller beeps twice to indicate the linking has started.
3. Press the linking button on the aircraft. The remote controller's status LED will be solid green if the linking is successful.

### Method 2: Using the app

1. Power on the remote controller and the aircraft.
2. Tap "Enter Device", select "Connect to the aircraft", and follow the prompts to start linking.
3. Select "Enter the Camera View" and tap  in camera view. Scroll to the bottom, tap "Remote Controller Linking" and tap "OK" to confirm.
4. The status LED blinks blue and the remote controller beeps twice to indicate the linking has started.
5. Press the linking button on the aircraft. The remote controller's status LED will be solid green if the linking is successful.

### Method 3: Using Quick Settings

1. Power on the remote controller and the aircraft.
2. Swipe down from the top of the screen to open Quick Settings. Tap  to start linking.
3. The status LED blinks blue and the remote controller beeps twice to indicate the linking has started.
4. Press the linking button on the aircraft. The remote controller's status LED will be solid green if the linking is successful.



- Make sure the remote controller is within 1.6 ft (0.5 m) of the aircraft during linking.
-

---

## Operating the Aircraft

### Controlling the Aircraft

This section explains how to control the orientation of the aircraft through the remote controller. Control can be set to Mode 1, Mode 2 or Mode 3.

#### Mode 1

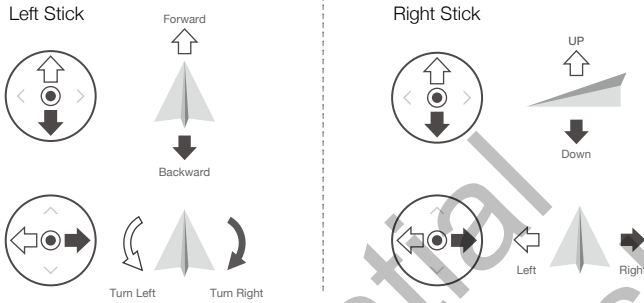

---

#### Mode 2

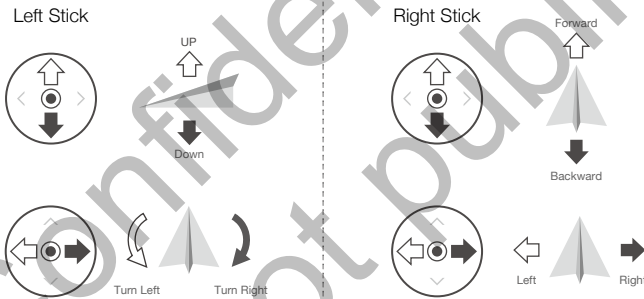

---

#### Mode 3

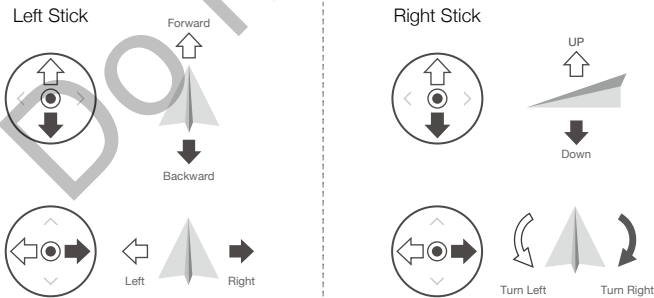







The Stick Mode is set to Mode 2 by default.

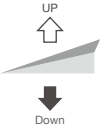

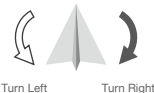
Stick Neutral/Mid-Point: Control sticks are centered.

Moving the Control Stick: Control sticks are pushed away from the center.

Remote Controller (Mode 2)	Aircraft	Remarks
<p>Left Stick</p> 	 <p>UP</p> <p>Down</p>	<p>Moving the left stick up and down changes the aircraft's elevation.</p> <p>Push the stick up to ascend and down to descend. When both sticks are centered, the aircraft will hover in place.</p> <p>The more the stick is pushed away from the center position, the faster the aircraft will change elevation. Always push the stick gently to prevent sudden and unexpected elevation changes.</p>
	 <p>Turn Left</p> <p>Turn Right</p>	<p>Moving the left stick to the left or right controls the rudder and rotation of the aircraft.</p> <p>Push the sick left to rotate the aircraft counter clockwise, and push the stick right to rotate the aircraft clockwise. If the stick is centered, the aircraft will maintain its current orientation.</p> <p>The more the stick is pushed away from the center position, the faster the aircraft will rotate.</p>
<p>Right Stick</p> 	 <p>Forward</p> <p>Backward</p>	<p>Moving the right stick up and down changes the aircraft's forward and backward pitch.</p> <p>Push the stick up to fly forward and down to fly backward. The aircraft will hover in place if the stick is centered.</p> <p>Push the stick further away from the center position for a larger pitch angle and faster flight.</p>
	 <p>Left</p> <p>Right</p>	<p>Moving the right stick control left and right changes the aircraft's left and right pitch.</p> <p>Push left to fly left and right to fly right. The aircraft will hover in place if the stick is centered.</p> <p>Push the stick further away from the center position for a larger pitch angle and faster flight.</p>



- Keep the remote controller away from magnetic materials to avoid it being affected by magnetic interference.
- To avoid damage, it is recommended that the control sticks are removed and stored in the storage slot on the remote controller during transportation or storage.

## Flight Mode Switch

Toggle the switch to select the flight mode. Choose between T-mode, P-mode, and S-mode.

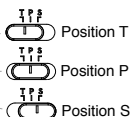
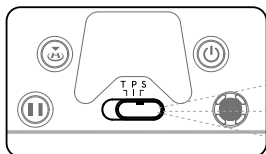

Position	Flight Mode
T	T-mode (Tripod)
P	P-mode (Positioning)
S	S-mode (Sport)

**T-mode (Tripod):** The aircraft utilizes GNSS and Camera Sensing systems to locate itself, stabilize, and navigate between obstacles. In this mode, the maximum flight speed is limited to 15.7 mph (25.2 kph). The responsiveness to stick movements is also reduced for smoother, more controlled movement.

**P-mode (Positioning):** P-mode works best when the GNSS signal is strong. The aircraft utilizes GNSS, Camera Sensing Systems, and an Infrared Sensing System to stabilize, avoid obstacles, and track moving subjects.

**S-mode (Sport):** The handling gain values of the aircraft are adjusted to enhance aircraft maneuverability. Note that Camera Sensing Systems are disabled in this mode.

Regardless of the position the switch is in on the remote controller, the aircraft begins in P-mode by the default. To switch flight modes, first go to camera view in the app, tap the  and enable "Multiple Flight tap Modes". After enabling multiple flight modes, toggle the switch to P then to S or T to switch flight and modes.

## RTH Button

Press and hold the RTH button to start Return to Home (RTH) and the aircraft will return to the last recorded Home Point. Press the button again to cancel RTH and regain control of the aircraft. Refer to the Return to Home section in the aircraft's user manual for more information about RTH.

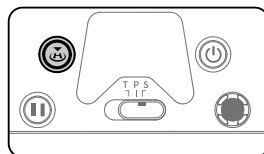

 In Advanced Dual Operator Mode, the remote controller without flight control cannot use this button to start and stop the RTH function.

## Customizable Buttons

The functions of the C1, C2 and 5D buttons are set in the app. The default configurations are as below:  
C1: Re-center the gimbal.

C2: To switch the camera view between different cameras.

Rotating the Gimbal Pan Control Dial by holding the Confirm Button: To control the camera zoom.

---

## Optimal Transmission Zone

Try to keep the aircraft inside the optimal transmission zone. If the signal is weak, adjust the antennas or fly the aircraft closer.

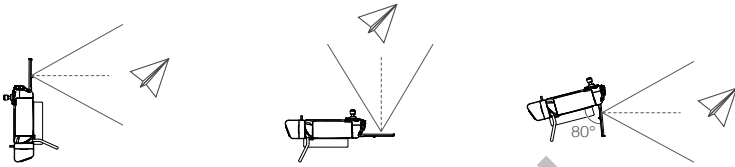

Make sure the antennas are facing towards the aircraft. When the angle between the antennas and the back of the Secure Controller is 80° or 180°, the connection between the remote controller and the aircraft can reach its optimal performance.

Note that the illustrations above do not reflect the actual distances between the user and aircraft and are for reference only.

- 
- ⚠ • Avoid using wireless devices that use the same frequency bands as the Secure Controller.
- In real operation, the app will issue a prompt to warn that the transmission signal is weak, and please adjust the antennas to ensure that the aircraft is back to the optimal transmission range.
- 

## Operating the Camera

Shoot videos and photos with the Focus / Shutter button and Record button on the remote controller.

### 1. Focus / Shutter Button

Press to take a photo. If Burst mode is selected, multiple photos will be taken if the button is continuously pressed. Set the Shutter mode in the app.

### 2. Record Button

Press once to start recording video and press again to stop.

- 
- ⚠ When using an aircraft firmware version is v02.02.01.02 or later, the record and the focus/shutter buttons on the remote controller are disabled during Mapping, Oblique, and Linear Flight missions to avoid accidentally interrupting operations. .
- 

## Operating the Gimbal

Use the left dial and right dial to adjust the gimbal pitch and pan.

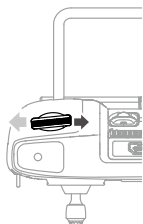

The left dial controls the gimbal tilt. Turn the dial to the right, and the gimbal will shift to point upwards. Turn the dial to the left, and the gimbal will shift to point downwards. The camera will remain in its current position when the dial is static.

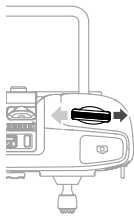

The right dial controls the gimbal pan. Turn the dial to the right, and the gimbal will shift clockwise. Turn the dial to the left, and the gimbal will shift counter clockwise. The camera will remain in its current position when the dial is static.

## Advanced Dual Operator Mode

### Introduction

The Explore2 supports Advanced Dual Operator Mode, which allows two remote controllers to connect to the same aircraft. In this mode, two remote controllers are of the same priority and have no pre-assigned roles. During operation, two pilots take control based on their requirements and decide which onboard device such as aircraft, gimbal and camera can be operated currently, making it more flexible to operate.

There are two types of control, including aircraft flight control and gimbal control. For the remote controller with aircraft flight control, it can control the orientation of the aircraft. For the remote controller with gimbal control, it can control the movement of the gimbal and camera operation.

### Configuring Advanced Dual Operator Mode

Before use, remote controller A and remote controller B must be linked separately. Follow these steps to complete linking:

#### Linking the Remote Controller

1. Launch App.
2. Enter "Camera" and tap . The remote controller is ready to link.
3. On the drop-down list of Advanced Dual Operator Mode, select remote controller as Controller A or Controller B. Tap the pop-up window to confirm linking.

#### Using Advanced Dual Operator Mode

1. Ensure two remote controllers have been linked and connected to the aircraft. The first connected remote controller is able to control all devices including aircraft, gimbal and camera by default, while the second one has no control of any device.
2. A remote controller that has control of a device can use a control stick, gimbal dial, button combinations, and UI icon to control the device, which is in line with a single remote controller. Otherwise, the device cannot be controlled. A remote controller that has no control of a device can still switch to the Camera View of the device. Only a remote controller that is able to control the orientation of the aircraft can initiate and cancel the Return to Home (RTH) procedure.
3. Users can take control of devices manually. First, switch to the Camera View of the device that you want to control. For aircraft flight control, switch to the Camera View of the FPV camera. Second, tap on the control icon on the upper left to take control. The 4-axis aircraft icon represents aircraft flight control, and the camera icon represents gimbal control.
4. When a user has aircraft flight control, press and hold the Control Lock icon to lock the aircraft flight control on the Camera page of the FPV camera.



- 
5. If a remote controller can only control the gimbal, it can use control sticks. If a user has both aircraft flight control and gimbal control, he/she can use control sticks to control the orientation of the aircraft, and gimbal dial to control the gimbal.
  6. When operating in Dual Remote Control Mode, control switching will be triggered if one remote controller is disconnected to an aircraft. At this point, gimbal control that the disconnected remote controller has will be transferred to the connected controller unconditionally. If the disconnected controller has aircraft flight control, the connected controller will receive takeover prompts and the pilot can decide whether to take over or not. For a negative decision or when a decision is not made within the given time, a failsafe logic will be triggered.
  7. During operation, if the disconnected controller reconnects to the aircraft, it has no control of any device by default. Pilots can take control according to their requirements.
  8. Settings related to gimbal and camera are only available to the remote controller that has control of gimbal and camera.
  9. Functions such as download and playback of gimbal and camera are only available to the remote controller that has control of gimbal and camera.
  10. Normally, both remote controllers can configure the flight controller, Camera Sensing system, video transmission, and Flight Battery. However, if aircraft flight control is locked, only the remote controller that has aircraft flight control can perform such configurations.
  11. Both remote controllers can perform operations that will not affect flight.
  12. Controller B does not support Mission upload for AI Spot-check.
  13. Controller A supports one-click upgrade when connecting to the aircraft and gimbal and camera. Controller B only supports remote controller upgrade.
  14. App log upload: Controller A supports uploading Controller A aircraft log and remote controller log, while Controller B only supports uploading Controller B remote controller log.
  15. Controller B does not support the upgrade of flight limits database.
  16. Users can control the zoom of the camera by using the joystick of the RC with gimbal control.

## Video Transmission Descriptions

Explore2 aircraft features radio technology, supports up to three 1080p video transmissions, and also supports single remote controller mode or dual remote controller mode.

1. Single remote controller mode: supports two 1080p video transmissions.
2. Dual remote controller mode: supports up to three 1080p video transmissions and each remote controller can select two of the video transmissions to display.

---

 Transmission resolution is limited by the output capability of different payloads.

---

## Status LED and Battery Level Indicators Description

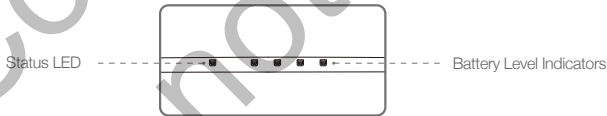

The battery level indicators displays the battery level of the controller. The status LED displays the linking status and warnings for control stick, low battery level, and high temperature.

Status LED	Description
Solid Red	The remote controller is not linked to an aircraft.
Solid Green	The remote controller is linked to an aircraft.
Blinks Blue	The remote controller is linking to an aircraft.
Blinks Red	The temperature of the remote controller is too high.
Blinks Yellow	The battery level of the remote controller is low.
Blinks Cyan	The control sticks are not centered.

Battery Level Indicators				Battery Level
●	●	●	●	75%~100%
●	●	●	○	50%~75%
●	●	○	○	25%~50%
●	○	○	○	0%~25%

### Secure Controller Warning Sounds

In certain scenarios that require a user warning, the Secure Controller will do so by vibrating and/or beeping. When the controller beeps and the status LED is solid green, this error may be related to the aircraft or flight status, and a warning will appear in the app. If this error is related to the Secure Controller, the controller's screen will display a warning or alert.

To disable the beeping, power on the remote controller, select "Sound" in Settings, and turn off "Notification volume".

- ⚠ Some prompts or warning sounds cannot be turned off, such as linking, high temperature alarm, low battery alarm, stick operation mode switching, stick and key power-on self-test alarm, etc.

### Firmware Update Using the Skycatch

#### Update Manager

1. Make sure the remote controller is powered off, and then connect the remote controller to a computer using a USB cable with dual-A ports.
2. Power on the remote controller. Tap  on USB data export mode.
3. Launch Skycatch Update Manager
4. Click the Secure Controller icon, and then "Firmware Update".
5. Select and confirm the firmware version you want to update.
6. Skycatch Update Manager will download and update the firmware automatically.
7. The remote controller will restart after update.

- ⚠
- Make sure the remote controller has more than 20% power before updating.
  - DO NOT disconnect the USB cable during the update when using Skycatch Update Manager.

The update takes approximately 15 minutes. Make sure the remote controller or the computer is connected to the internet during the update.

---

## Button Combinations

Some frequently-used features can be activated by using button combinations. To use button combinations, hold the back button and then press the other button.

### Checking the available button combinations

Hold the Back button until the controller vibrates to check button combinations:

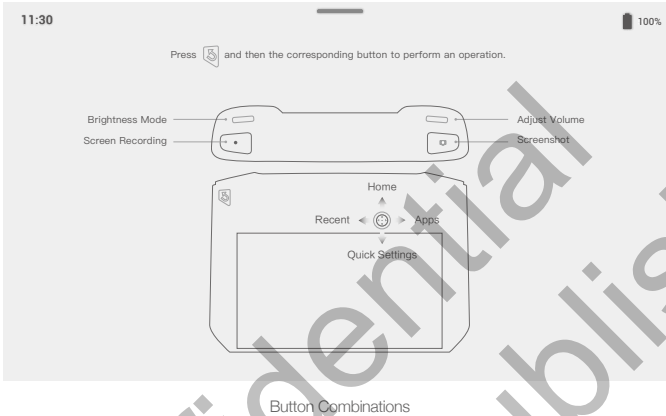

### Using Button Combinations

The functions of the button combinations cannot be changed. The following table displays the function of each button combination.

Button Combinations	Description
Function Button + Right Wheel	Adjust the system volume
Function Button + Left Wheel	Adjust the screen brightness
Function Button + Record Button	Record the screen
Function Button + Focus/Shutter Button	Screenshot the screen
Function Button + 5D Button (up)	Return to Homepage
Function Button + 5D Button (down)	Open Quick Settings
Function Button + 5D Button (left)	Check recently opened apps
Function Button + 5D Button (right)	Open App Center

---

## Calibrating the Compass

After the remote controller is used in places with electro-magnetic interference, the compass may need to be calibrated. A warning prompt will appear if the remote controller's compass requires calibration. Tap the warning pop-up to start calibrating. In other cases, follow the steps below to calibrate your remote controller.

1. Enter the App Center, tap , and scroll down and tap Compass.
2. Follow the diagram on the screen to calibrate your remote controller.
3. The user will receive a prompt when the calibration is successful.

## Blocking Third-party Notifications

To ensure safe flight, we recommend to disable third-party notifications before each flight. Follow the steps below to disable third-party notifications.

1. Enter the App Center, tap , and scroll down and tap Notifications.
2. Enable "Aerial Photography Do Not Disturb Mode".

## HDMI

A monitor can display the remote controller's interface by connecting the remote controller to a monitor using a HDMI cable. Follow the steps below to enable the HDMI connection.

1. Swipe down from the top of the screen to open Quick Settings.
2. Follow the diagram on the screen to calibrate your remote controller. Tap HDMI to enable or disable the HDMI connection. Hold to enter settings and adjust HDMI resolution, rotation, output mode, and screen zoom.

## Flight

---

This section describes safe flight practices and flight restrictions.

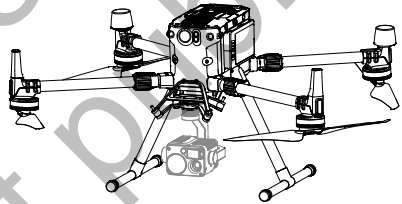

# Flight

Ensure that all flights are carried out in an open area. It is important to understand basic flight guidelines for the safety of both you and those around you. Refer to the Disclaimer and Safety Guidelines for more information.

## Flight Environment Requirements

1. DO NOT use the aircraft in severe weather conditions such as where wind speeds exceed 15 m/s. When flying in rain, refer to the flight requirements listed in the IP45 Protection Rating section on Page 38.
2. When flying in open areas, tall and large metal structures may affect the accuracy of the onboard compass and GNSS system. Make sure to operate the aircraft by following the prompts in the app.
3. Avoid obstacles, crowds, high voltage power lines, trees, and bodies of water.
4. Minimize interference by avoiding areas with elevated levels of electromagnetism, including base stations and radio transmission towers.
5. Aircraft and battery performance are subject to environmental factors such as air density and temperature. Be very careful when flying at high altitudes, as battery and aircraft performance may be affected.
6. The compass and GNSS will not work in Polar Regions. Fly carefully.

Confidential  
Do not publish

---

## Flight Restrictions

### Introduction

UAV operators should abide by all flight regulations established by the relevant government and regulatory agencies, including the ICAO and the FAA.

### Maximum Altitude & Radius Restrictions

Maximum flight altitude restricts an aircraft's flight altitude, while maximum radius restricts its distance.

Confidential  
Do not publish



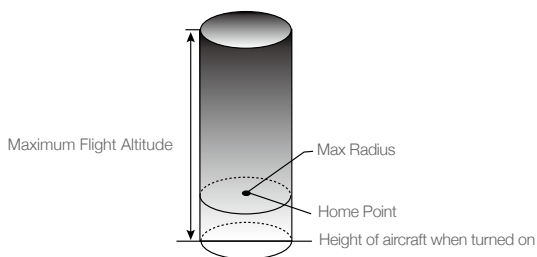

### Strong GNSS Signal

Restriction	Description
Max Altitude	Aircraft's altitude cannot exceed the specified value. Maximum Flight Altitude reached. Adjust your altitude using FC Settings if required.
Max Radius	Flight distance cannot exceed the specified value. Maximum Flight Distance reached. Adjust your distance using FC Settings if required.

### Weak GNSS Signal

Restriction	Description
Max Altitude	Altitude is restricted to 26 ft. (8 m) when GNSS signal is weak and the Camera Sensing System is activated. Altitude is restricted to 98 ft. (30 m) when GNSS signal is weak and the Camera Sensing System is deactivated. Maximum Flight Altitude reached. Adjust your altitude using MC Settings if required.
Max Radius	No limit. N/A

- ⚠
- When an aircraft exceeds a specified limit, the pilot can still control the aircraft but it will be unable to fly any farther.
  - For safety reasons, DO NOT fly near airports, highways, railway stations, railway lines, city centers, or other sensitive areas. Only fly aircraft in areas that are within your direct line of sight.

---

**This page  
intentionally left  
blank**

Confidential  
Do not publish

---

## Pre light Checklist

1. Remote controller, Battery, and display device are fully charged.
2. Frame arms are unfolded and locked firmly, landing gears are mounted firmly, and batteries are locked firmly.
3. All the devices' firmware is up-to-date.
4. microSD card has been inserted, if necessary.
5. Gimbal is functioning normally.
6. Motors can start and are functioning normally.
7. The Skycatch Secure Controller is successfully connected to the aircraft.
8. Ensure that the sensors for the Sensing Systems are clean.
9. DO NOT face the battery connector downwards to the ground to avoid getting dust or water into the battery connector.
10. Make sure that the gimbal dampener is without obvious wear and tear, and the gimbal anti-drop rope has been fastened.

## Calibrating the Compass

Only calibrate the compass when the app or the status indicator prompts you to do so. Observe the following rules when calibrating your compass:

-  DO NOT calibrate your compass where there is a chance of strong magnetic interference, such as near magnets, parking structures, or steel reinforcements underground.
  - DO NOT carry ferromagnetic materials with you during calibration such as cellular phones.
  - The app will notify you if the compass is affected by strong interference after calibration is complete. Follow the prompts to resolve the compass issue.
-

---

## Calibration Procedures

Choose an open area to carry out the following procedures.

1. Tap the Aircraft Status Bar in the app and select Calibrate, then follow the on-screen instructions.
2. Hold the aircraft horizontally and rotate it 360 degrees. The Aircraft Status Indicators will go solid green.

3. Hold the aircraft vertically, with the nose pointing downward, and rotate it 360 degrees around the center axis. Re-calibrate the aircraft if the aircraft status indicators blink red.

Confidential  
Do not publish



If the Aircraft Status Indicator blinks red and yellow after the calibration procedure, move your aircraft to a different location and try again.



- DO NOT calibrate the compass near metal objects such as a metal bridge, cars, scaffolding.
  - If the aircraft status indicators are blinking red and yellow alternately after placing the aircraft on the ground, the compass has detected magnetic interference. Please change your location.
-

## Starting/Stopping the Motors

### Starting Motors

The Combination Stick Command (CSC) is used to start the motors. Push both sticks to the bottom inner or outer corners to start the motors. Once the motors start spinning, release both sticks simultaneously.

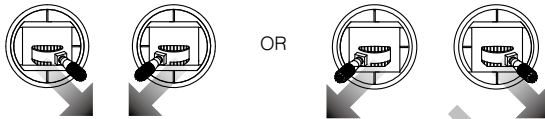

### Stopping the Motors

There are two ways to stop the motors:

1. When the aircraft has landed, push and hold the left stick down. The motors will stop after three seconds. (Recommended).
2. When aircraft has landed, push the left stick down ①, then conduct the same CSC that was used to start the motors, as shown above ②. Motors will stop immediately. Release both sticks once motors stop.

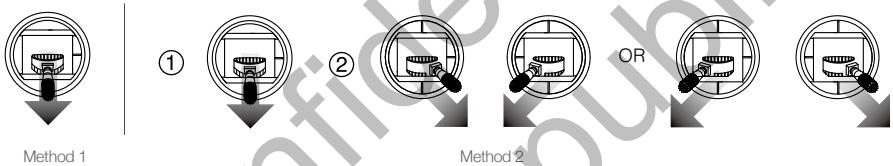

### Emergency Propeller Stop

The Combination Stick Command (CSC) can be used to execute the emergency propeller stop once the flight controller detects critical error during flight.

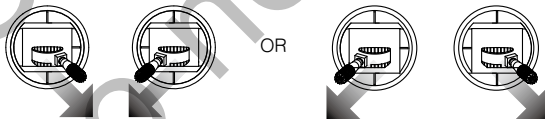

## Flight Test

### Takeoff/Landing Procedures

1. Place the aircraft in an open, flat area with the battery level indicators facing towards you.
2. Turn on the remote controller, then turn on the aircraft.
3. Launch app and enter the Camera View.
4. Wait until the Aircraft Status Indicators blink green (with single point positioning) or blink green and blue alternately (RTK).
5. If the Flight Battery temperature is low, use the self-heating function to heat the batteries to ensure the temperature is suitable for the aircraft to take off.
6. Turn on the motors using CSC and push the left stick up slowly to take off.
7. To land, hover over a level surface and gently pull down on the left stick to descend.

- 
8. After landing, execute the CSC command or hold the left stick at its lowest position until the motors stop.
  9. Turn off the Flight Battery first, then the remote controller.

- 
- ⚠
- When the Aircraft Status Indicators blink yellow rapidly during flight, the aircraft has entered Failsafe mode.
  - A low battery level warning is indicated by the Aircraft Status Indicators blinking red slowly or rapidly during flight.
  - Watch our video tutorials for more flight information.
- 

### Three-propeller Emergency Landing

During flight, if the aircraft lacks one lift output (e.g. propulsion system failure of a motor), it will automatically switch to the Three-propeller Emergency Landing Mode. The flight controller will try to maintain the stability and controllability of attitude and velocity, and make the aircraft automatically descent in this mode. This mode enables a user to land the aircraft onto a safe zone by controlling the aircraft, helps to reduce the chance for the aircraft and payload to drop, and damage the people and property on the ground.

When the aircraft enters the Three-propeller Emergency Landing Mode, the remote controller will alert the user by vibrating. At this time, the aircraft will enter rapid spin and automatically descend by default. The stick that controls back and forth movement will be adjusted to control the north-south movement and the stick that controls the left and right movement will be adjusted to control the west-east movement. The user can operate the sticks to move the aircraft to the appropriate landing area as soon as possible. When the aircraft reaches near to the ground, user can use the Emergency propeller stop to land the aircraft to minimize the drop loss caused by the aircraft spin.

- 
- ⚠
- Three-propeller Emergency Landing requires that the takeoff weight of the aircraft to be less than 7.7 kg and it should work in open space with the flight height that exceeds 10 m.
  - Once such a failure occurs, please move the aircraft immediately away from people and valuables, and land on a level and soft surface (e.g. grass) to reduce damaging the aircraft.
  - If a propeller is damaged but the motor is still working normally, the aircraft will not enter the Three-propeller Emergency Landing Mode.
  - Three-propeller Emergency Landing is only used as an emergency protection function when the propulsion system fails. Please do not actively trigger it.
  - Make sure that all firmware is up-to-date.
  - After landing, contact Skycatch support for the propulsion system maintenance as soon as possible.
-

## Appendix

---

Confidential  
Do not publish

# Appendix

## Specifications

Aircraft	
Dimensions (Unfolded, propellers excluded)	810×670×430 mm (L×W×H)
Dimensions (Folded)	430×420×430 mm (L×W×H)
Diagonal Wheelbase	895 mm
Weight (Batteries excluded)	3600 g
Max Payload	2700 g
Max Takeoff Weight	9000 g
Operating Frequency	2.400 - 2.4835 GHz; 5.725 - 5.850 GHz
Transmitter Power (EIRP)	2.400 - 2.4835 GHz: 29.5 dBm (FCC); 18.5 dBm (CE); 18.5 dBm (SRRC); 18.5 dBm (MIC) 5.725 - 5.850 GHz: 28.5 dBm (FCC); 12.5 dBm (CE); 28.5 dBm (SRRC)
Hovering Accuracy (Windless or breezy)	Vertical: ±0.1 m (Camera Sensing System enabled)±0.5 m (P-mode with GPS)  Horizontal: ±0.3 m (Camera Sensing System enabled)±1.5 m (P-mode with GPS)
Max Angular Velocity	Pitch: 300°/s, Yaw: 100°/s
Max Pitch Angle	30° (P-mode and Forward Camera Sensing System enabled: 25°)
Max Ascent Speed	6 m/s
Max Descent Speed (vertical)	5 m/s
Max Descent Speed (tilt)	7 m/s
Max Horizontal Speed	23 m/s
Max Service Ceiling Above Sea Level	5000 m (with 2110 Propellers, and takeoff weight ≤7 kg) / 7000 m (with 2195 High Altitude Low Noise Propellers, and takeoff weight ≤7 kg)
Max Wind Resistance	15 m/s
Max Forward Flight Time (Sea level)	45 minutes (Load weight 700 g)
Max Hover Time (Sea level)	43 minutes (Load weight 700 g)
Motor Model	6009
Propeller Model	2110
Supported Gimbals	Skycatch Vision1 Skycatch Scan1
Supported Gimbal Configurations	Dual Downward Gimbals, Single Upward Gimbal, Single Downward Gimbal, Single Downward Gimbal+Single Upward Gimbal, Dual Downward Gimbals+Single Upward Gimbal



Other Supported Products	CSM Radar, Manifold 2
Ingress Protection Rating	IP45
GNSS	GPS+GLONASS+BeiDou+Galileo
Operating Temperature	-20° to 50°C (-4° to 122° F)
<b>Secure Controller</b>	
Operation Frequency Range	2.400 - 2.4835 GHz; 5.725 - 5.850 GHz*
Max Transmission Distance (Unobstructed, free of interference)	NCC / FCC: 15 km CE / MIC: 8 km SRRC: 8 km
Transmitter Power (EIRP)	2.400 - 2.4835 GHz: 29.5 dBm (FCC); 18.5 dBm (CE) ; 18.5 dBm (SRRC); 18.5 dBm (MIC) 5.725 - 5.850 GHz: <b>5.510-5.250GHz</b> 28.5 dBm (FCC); 12.5 dBm (CE); 20.5 dBm (SRRC)
External Battery	Name: RC Battery Capacity: 4920 mAh; Voltage: 7.6 V Battery Type: LiPo; Energy: 37.39 Wh Charge Time (Using Charging Station): 70 min (15° to 45° C); 130 min (0° to 15° C)
Built-in Battery	Battery Type: 18650 Li-ion (5000 mAh @ 7.2 V) Charge Type : Supports USB charger rated 12 V / 2 A Rated Power: 17 W** Charge Time: 2 hours and 15 minutes (Using a USB charger rated 12 V / 2 V)
Working Time	Built-in Battery: Approx. 2.5 hours Built-in Battery + External Battery: Approx. 4.5 hours
Power Supply Voltage / Current (USB-A port)	5 V / 1.5 A
Operation Temperature Range	-20° to 40° C (-4° to 104° F)
Storage Capacity	Rom: 32 GB + scalable with microSD
<b>camera sensing System</b>	
Obstacle Sensing Range	Forward / Backward / Left / Right: 0.7 - 40 m Upward / Downward: 0.6 - 30 m
FOV	Forward / Backward / Downward: 65°(H), 50°(V) Left / Right / Upward: 75°(H), 60°(V)
Operating Environment	Surfaces with clear patterns and adequate lighting (> 15 lux)
<b>Infrared Sensing System</b>	
Obstacle Sensing Range	0.1 - 8 m
FOV	30°
Operating Environment	Large, diffuse, and reflective obstacles (reflectivity >10%)

---

## Flight Battery

Capacity	5935 mAh
Voltage	52.8 V
Battery Type	LiPo 12S
Energy	274 Wh
Net Weight (Single One)	Approx. 1.35 kg
Operating Temperature	-4° to 122°F (-20° to 50°C)
Storage Temperature	71.6° to 86°F (22° to 30°C)
Charging Temperature	41° to 104°F (5° to 40°C)
Max Charging Power	470 W

## Auxiliary Light

Effective Illumination Distance	5 m
Illumination Mode	60 Hz, solid on

## FPV Camera

Resolution	960p
FOV	145°
Frame rate	30fps

\* Local regulations in some countries prohibit the use of the 5.8 GHz and 5.2 GHz frequencies and in some regions the 5.2 GHz frequency band is only allowed for indoor use.

\*\* The Secure Controller will supply power for the mobile device installed, which may affect the above mentioned specifications.

## Firmware Update

Use the Skycatch Update Manager to update the remote controller, aircraft and other connected devices.

Gimbal firmware must be updated via a microSD card.

The firmware of the Skycatch Vision1 cannot be updated using Skycatch Update Manager for Explore2. If the firmware of the aircraft is updated using Skycatch Update Manager for Explore2 while the Skycatch Vision1 is attached, only the aircraft firmware will be updated. Use an SD card to update the firmware of Skycatch Vision1.

The CSM Radar is not supported when using an aircraft firmware version of v01.00.0214 or earlier. Update the aircraft firmware to use the radar. Make sure the CSM Radar is correctly mounted to the aircraft and follow the prompts in the app to update the CSM Radar firmware.

---

## Using Skycatch Update Manager for Explore2

For the remote controller and aircraft users can connect each device to the software and then run a firmware update to update firmware on the devices accordingly.

### Remote Controller Firmware Update

1. Power on the remote controller and aircraft. Connect the remote controller to a PC with a USB cable with dual A-port.
2. Tap  to set as USB data export mode in the remote controller's Quick Settings.
3. Click the corresponding device name and then the firmware update tag.
4. Select the firmware version required. Make sure to connect to the Internet when downloading the firmware.
5. Restart the device after the firmware update is complete.

### Aircraft Firmware Update

1. Power on the aircraft. Connect the aircraft to a PC with a Type-C USB cable.
2. Run the Skycatch Update Manager. Click the corresponding device name and then the firmware update tag.
3. Select the firmware version required. Make sure to connect to the Internet when downloading the firmware.
4. Restart the device after the firmware update is complete.



Radar firmware updates are included with aircraft firmware updates.

---



- The battery firmware is included in the aircraft firmware. Be sure to update all the batteries' firmware.
  - The aircraft battery level should be above 25% and the remote controller battery level should be above 50% for the firmware update process.
  - Make sure all the devices are connected normally during update.
  - It is normal that the gimbal will go limp, the aircraft status indicator blinks abnormally when the aircraft reboots. Wait patiently until the update is complete.
  - Make sure to keep the aircraft away from people and animals during firmware update, system calibration and parameter setting.
  - Be sure to update the firmware to the latest version to ensure flight safety.
  - After the firmware update is completed, the remote controller and the aircraft may be disconnected. If necessary, re-link them.
-