



# FCC RF Test Report

**APPLICANT** : Mundo Reader S.L.  
**EQUIPMENT** : Mobile Phone  
**BRAND NAME** : Suro, BQ  
**MODEL NAME** : Carbon, Aquaris X3  
**FCC ID** : 2AN87CARBON  
**STANDARD** : FCC Part 15 Subpart E §15.407  
**CLASSIFICATION** : (NII) Unlicensed National Information Infrastructure

The product was received on Oct. 14, 2019 and testing was completed on Jan. 23, 2020. We, Sporton International (Kunshan) Inc., would like to declare that the tested sample has been evaluated in accordance with the test procedures and has been in compliance with the applicable technical standards.

The test results in this report apply exclusively to the tested model / sample. Without written approval of Sporton International (Kunshan) Inc., the test report shall not be reproduced except in full.

Jason Jia

Reviewed by: Jason Jia / Supervisor

James Huang

Approved by: James Huang / Manager



**Sporton International (Kunshan) Inc.**

**No. 1098, Pengxi North Road, Kunshan Economic Development Zone Jiangsu Province 215300  
People's Republic of China**



# TABLE OF CONTENTS

**REVISION HISTORY..... 3**

**SUMMARY OF TEST RESULT ..... 4**

**1 GENERAL DESCRIPTION ..... 5**

    1.1 Applicant ..... 5

    1.2 Manufacturer ..... 5

    1.3 Product Feature of Equipment Under Test..... 5

    1.4 Product Specification of Equipment Under Test..... 6

    1.5 Modification of EUT ..... 6

    1.6 Testing Location ..... 6

    1.7 Test Software ..... 7

    1.8 Applicable Standards..... 7

**2 TEST CONFIGURATION OF EQUIPMENT UNDER TEST ..... 8**

    2.1 Carrier Frequency and Channel ..... 8

    2.2 Test Mode ..... 9

    2.3 Connection Diagram of Test System ..... 10

    2.4 Support Unit used in test configuration and system ..... 11

    2.5 EUT Operation Test Setup ..... 11

    2.6 Measurement Results Explanation Example..... 11

**3 TEST RESULT ..... 12**

    3.1 6dB and 26dB and 99% Occupied Bandwidth Measurement ..... 12

    3.2 Maximum Conducted Output Power Measurement ..... 15

    3.3 Power Spectral Density Measurement ..... 16

    3.4 Unwanted Emissions Measurement ..... 18

    3.5 AC Conducted Emission Measurement..... 22

    3.6 Automatically Discontinue Transmission ..... 24

    3.7 Antenna Requirements ..... 25

**4 LIST OF MEASURING EQUIPMENT ..... 26**

**5 UNCERTAINTY OF EVALUATION ..... 27**

**APPENDIX A. CONDUCTED TEST RESULTS**

**APPENDIX B. AC CONDUCTED EMISSION TEST RESULT**

**APPENDIX C. RADIATED SPURIOUS EMISSION**

**APPENDIX D. DUTY CYCLE PLOTS**

**APPENDIX E. SETUP PHOTOGRAPHS**





### SUMMARY OF TEST RESULT

Report Section	FCC Rule	Description	Limit	Result	Remark
3.1	15.403(i)	6dB, 26dB and 99% Occupied Bandwidth	> 500kHz	Pass	-
3.2	15.407(a)	Maximum Conducted Output Power	≤ 30 dBm	Pass	-
3.3	15.407(a)	Power Spectral Density	≤ 30 dBm/500kHz	Pass	-
3.4	15.407(b)	Unwanted Emissions	15.407(b)(4)(i) & 15.209(a)	Pass	Under limit 8.40 dB at 76.560 MHz
3.5	15.207	AC Conducted Emission	15.207(a)	Pass	Under limit 8.15 dB at 14.138 MHz
3.6	15.407(c)	Automatically Discontinue Transmission	Discontinue Transmission	Pass	-
3.7	15.203 & 15.407(a)	Antenna Requirement	N/A	Pass	-

Remark: Not required means after assessing, test items are not necessary to carry out.

**Declaration of Conformity:**

The test results with all measurement uncertainty excluded are presented in accordance with the regulation limits or requirements declared by manufacturers.

**Comments and Explanations:**

The declared of product specification for EUT presented in the report are provided by the manufacturer, and the manufacturer takes all the responsibilities for the accuracy of product specification.



# 1 General Description

## 1.1 Applicant

Mundo Reader S.L.

Calle Sofia, 10, Parque Industrial Tecnológico 28232 Las Rozas Europolis, Madrid, Spain

## 1.2 Manufacturer

Mundo Reader S.L.

Calle Sofia, 10, Parque Industrial Tecnológico 28232 Las Rozas Europolis, Madrid, Spain

## 1.3 Product Feature of Equipment Under Test

Product Feature	
Equipment	Mobile Phone
Brand Name	Suro, BQ
Model Name	Carbon, Aquaris X3
FCC ID	2AN87CARBON
EUT supports Radios application	GSM/WCDMA/LTE/NFC WLAN 2.4GHz 802.11b/g/n HT20/HT40 WLAN 5GHz 802.11a/n HT20/HT40 WLAN 5GHz 802.11ac VHT20/VHT40 Bluetooth BR/EDR/LE FM Receiver and GNSS
IMEI Code	Conducted:N/A Coduction: 955379058091132/955379058096636 Radiation: 355379058091033/355379058096537
HW Version	1.A.1
SW Version	1.2.0_20200211-1558
EUT Stage	Identical Prototype

Remark: The above EUT's information was declared by manufacturer. Please refer to the specifications or user's manual for more detailed description.



### 1.4 Product Specification of Equipment Under Test

Standards-related Product Specification	
<b>Tx/Rx Channel Frequency Range</b>	5745 MHz ~ 5825 MHz
<b>Maximum Output Power</b>	<b>&lt;5745 MHz ~ 5825 MHz&gt;</b> 802.11a : 16.07 dBm / 0.0405 W 802.11n HT20 : 15.98 dBm / 0.0396 W 802.11n HT40 : 16.48 dBm / 0.0445 W 802.11ac VHT20: 15.91 dBm / 0.0390 W 802.11ac VHT40: 16.36 dBm / 0.0433 W
<b>99% Occupied Bandwidth</b>	802.11a : 17.68 MHz 802.11n HT20 : 18.88 MHz 802.11n HT40 : 36.66 MHz
<b>Type of Modulation</b>	802.11a/n : OFDM (BPSK / QPSK / 16QAM / 64QAM) 802.11ac : OFDM (BPSK / QPSK / 16QAM / 64QAM / 256QAM)
<b>Antenna Type / Gain</b>	PIFA Antenna with gain -1.00 dBi

Note: For 802.11n HT20 / ac VHT20 and 802.11n HT40 / ac VHT40 mode, the whole testing have assessed only 802.11n HT20/ HT40 by referring to their maximum conducted power.

### 1.5 Modification of EUT

No modifications are made to the EUT during all test items.

### 1.6 Testing Location

Sporton International (Kunshan) Inc. is accredited to ISO/IEC 17025:2017 by American Association for Laboratory Accreditation with Certificate Number 5145.02.

<b>Test Firm</b>	Sporton International (Kunshan) Inc.		
<b>Test Site Location</b>	No. 1098, Pengxi North Road, Kunshan Economic Development Zone Jiangsu Province 215300 People's Republic of China TEL : +86-512-57900158 FAX : +86-512-57900958		
<b>Test Site No.</b>	<b>Sporton Site No.</b>	<b>FCC Designation No.</b>	<b>FCC Test Firm Registration No.</b>
	CO01-KS 03CH06-KS TH01-KS	CN1257	314309



### 1.7 Test Software

Item	Site	Manufacture	Name	Version
1.	03CH06-KS	AUDIX	E3	6.2009-8-24al
2.	CO01-KS	AUDIX	E3	6.2009-8-24

### 1.8 Applicable Standards

According to the specifications of the manufacturer, the EUT must comply with the requirements of the following standards:

- ♦ 47 CFR Part 15 Subpart E
- ♦ FCC KDB 789033 D02 General UNII Test Procedures New Rules v02r01.
- ♦ ANSI C63.10-2013

**Remark:**

1. All test items were verified and recorded according to the standards and without any deviation during the test.
2. This EUT has also been tested and complied with the requirements of FCC Part 15, Subpart B, recorded in a separate test report.



## 2 Test Configuration of Equipment Under Test

- a. The EUT has been associated with peripherals and configuration operated in a manner tended to maximize its emission characteristics in a typical application. Frequency range investigated: conduction emission (150 kHz to 30 MHz), radiation emission (9 kHz to the 10th harmonic of the highest fundamental frequency or to 40 GHz, whichever is lower). For radiated measurement, pre-scanned in three orthogonal panels, X, Y, Z. The worst cases (Y plane) were recorded in this report.
- b. AC power line Conducted Emission was tested under maximum output power.

### 2.1 Carrier Frequency and Channel

Frequency Band	Channel	Freq. (MHz)	Channel	Freq. (MHz)
5725-5850 MHz Band 4 (U-NII-3)	149	5745	157	5785
	151*	5755	159*	5795
	153	5765	161	5805
	-	-	165	5825

Note: The above Frequency and Channel in "\*" were 802.11n HT40 and 802.11ac VHT40.





## 2.2 Test Mode

Final test modes are considering the modulation and worse data rates as below table.

Modulation	Data Rate
802.11a	6 Mbps
802.11n HT20	MCS0
802.11n HT40	MCS0

<b>AC Conducted Emission</b>	Mode 1 : GSM 850 Idle + Bluetooth Link + WLAN Link(5G) + Earphone + USB Cable 1(Charing from Adapter 1)
<b>Remark:</b> For Radiated Test Cases, The tests were performance with Adapter 1, Earphone and USB Cable 1 for sample 1.	

Ch. #		Band IV : 5725-5850 MHz		
		802.11a	802.11n HT20	802.11n HT40
L	Low	149	149	151
M	Middle	157	157	-
H	High	165	165	159

## 2.3 Connection Diagram of Test System

For Radiation

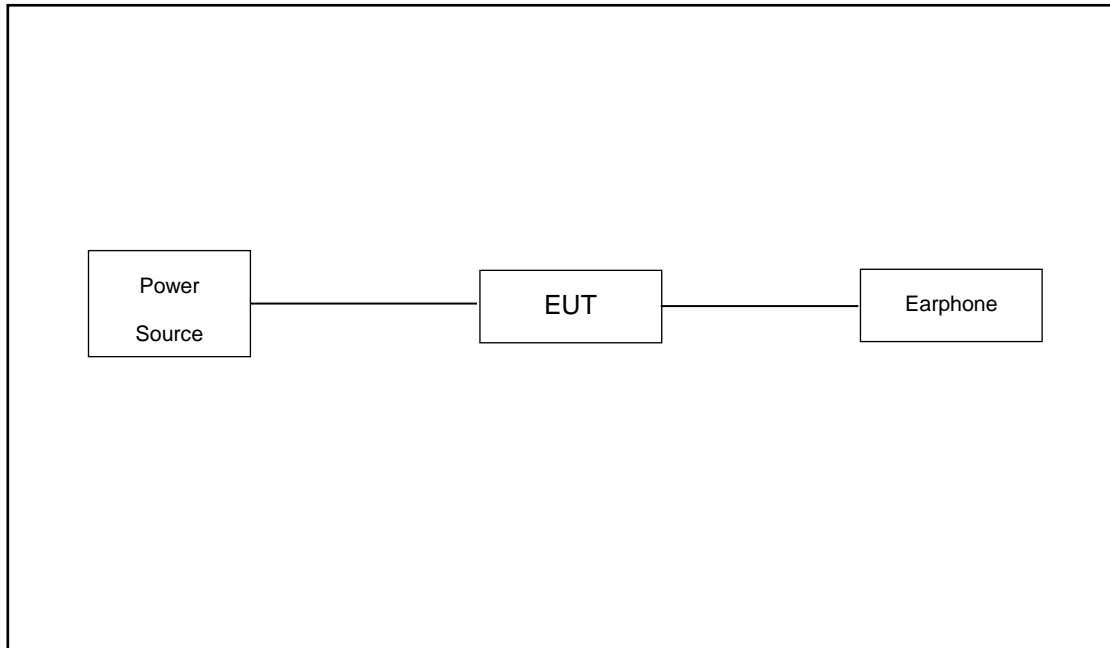

For Conducted Emission

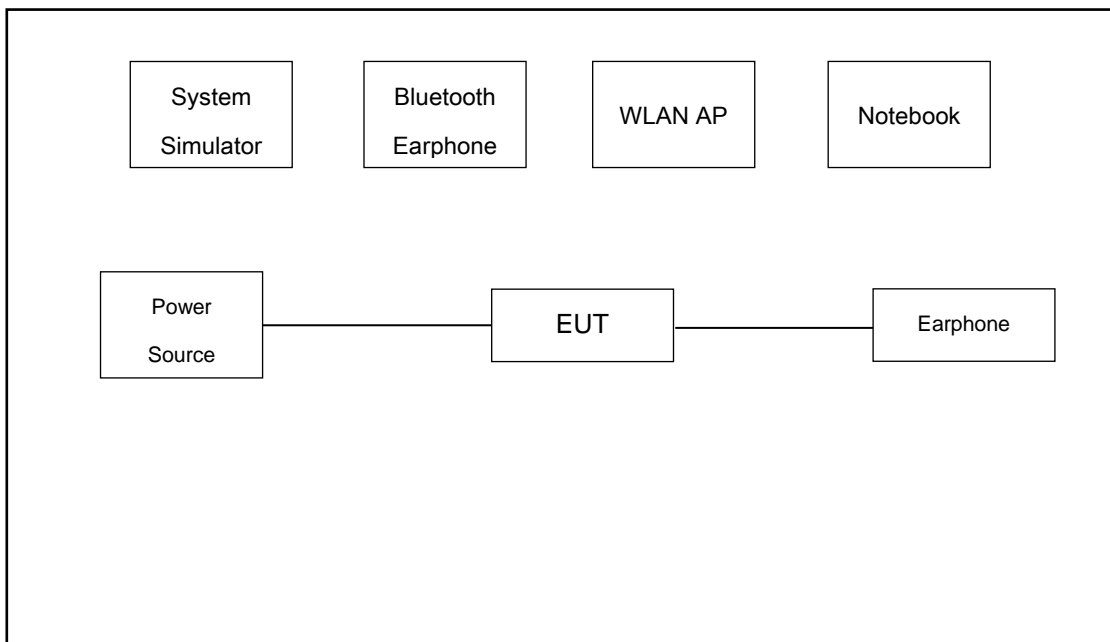

## 2.4 Support Unit used in test configuration and system

Item	Equipment	Trade Name	Model Name	FCC ID	Data Cable	Power Cord
1.	LTE Base Station	Anritsu	MT8820C	N/A	N/A	Unshielded,1.8m
2.	WLAN AP	D-link	DIR-655	KA21R655B1	N/A	Unshielded,1.8m
3.	Notebook	Lenovo	G480	QDS-BRCM1050I	N/A	AC I/P: Unshielded, 1.8 m DC O/P: Shielded, 1.8 m
4.	Bluetooth Earphone	Lenovo	LBH308	N/A	N/A	N/A
5.	Adapter 1(Type C)	N/A	N/A	N/A	N/A	N/A
6.	Earphone	N/A	N/A	N/A	N/A	Unshielded,1.2m
7.	SD Card	Kingston	8GB	N/A	N/A	N/A

## 2.5 EUT Operation Test Setup

For WLAN RF test items, an engineering test program was provided and enabled to make EUT continuously transmit/receive.

For AC power line conducted emissions, the EUT was set to connect with the WLAN AP under large package sizes transmission.

## 2.6 Measurement Results Explanation Example

**For all conducted test items:**

The offset level is set in the spectrum analyzer to compensate the RF cable loss between EUT conducted output port and spectrum analyzer. With the offset compensation, the spectrum analyzer reading level is exactly the EUT RF output level.

Example :

The spectrum analyzer offset is derived from RF cable loss.

*Offset = RF cable loss*

Following shows an offset computation example with cable loss 6.6 dB.

$$\begin{aligned} \text{Offset(dB)} &= \text{RF cable loss(dB)}. \\ &= 6.6 \text{ (dB)} \end{aligned}$$

### 3 Test Result

#### 3.1 6dB and 26dB and 99% Occupied Bandwidth Measurement

##### 3.1.1 Description of 6dB and 26dB and 99% Occupied Bandwidth

The minimum 6 dB bandwidth shall be at least 500 kHz.

26dB and 99% Occupied bandwidth are reporting only.

##### 3.1.2 Measuring Instruments

The measuring equipment is listed in the section 4 of this test report.

##### 3.1.3 Test Procedures

1. The testing follows FCC KDB 789033 D02 General UNII Test Procedures New Rules v02r01. Section C) Emission bandwidth for the band 5.725-5.85GHz
2. Set RBW = 100kHz.
3. Set the VBW  $\geq 3 \times$  RBW.
4. Detector = Peak.
5. Trace mode = max hold
6. Measure the maximum width of the emission that is 6 dB down from the peak of the emission.
7. Measure and record the results in the test report.

##### 3.1.4 Test Setup

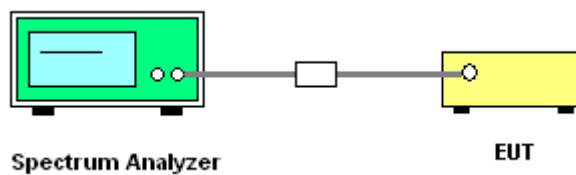



### 3.1.5 Test Result of 6dB Bandwidth

Please refer to Appendix A.

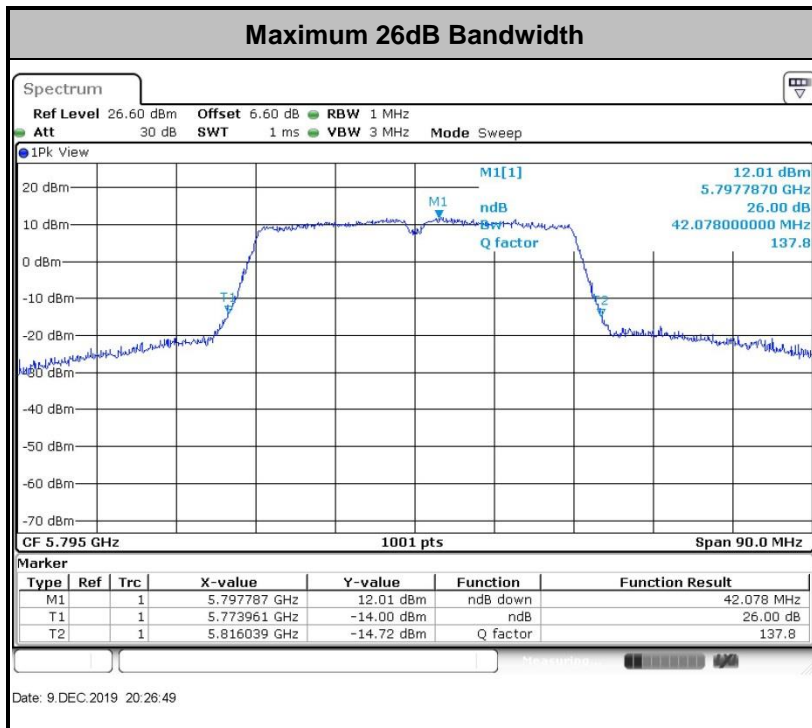
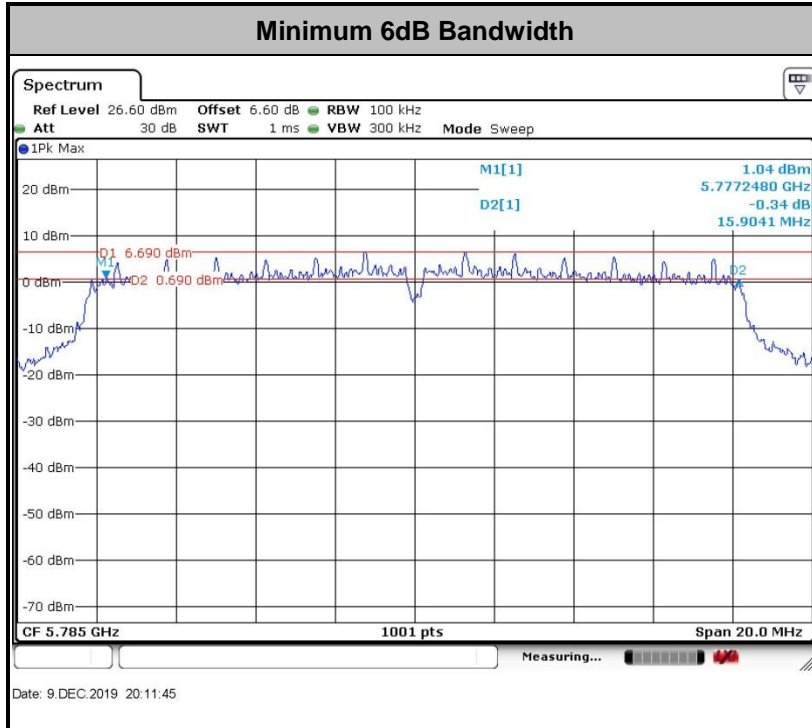

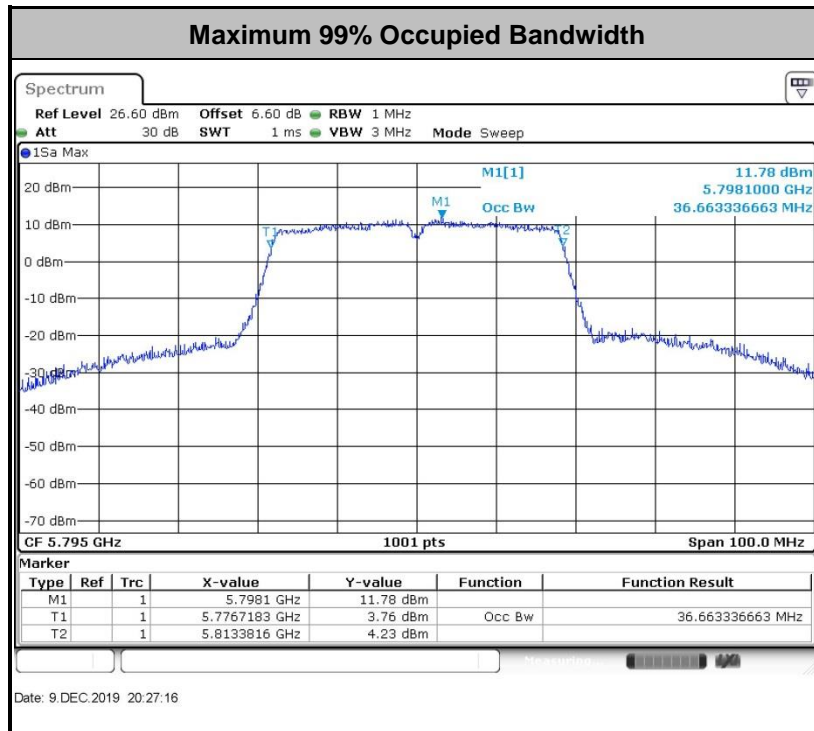

**Note:** The occupied channel bandwidth is maintained within the band of operation for all of the modulations.

## 3.2 Maximum Conducted Output Power Measurement

### 3.2.1 Limit of Maximum Conducted Output Power

For the band 5.725–5.85 GHz, the maximum conducted output power over the frequency band of operation shall not exceed 1 W.

If transmitting antennas of directional gain greater than 6 dBi are used, the peak output power shall be reduced by the amount in dB that the directional gain of the antenna exceeds 6 dBi.

### 3.2.2 Measuring Instruments

The measuring equipment is listed in the section 4 of this test report.

### 3.2.3 Test Procedures

The testing follows Method PM of FCC KDB 789033 D02 General UNII Test Procedures New Rules v02r01.

Method PM (Measurement using an RF average power meter):

1. Measurement is performed using a wideband RF power meter.
2. The EUT is configured to transmit continuously with a consistent duty cycle at its maximum power control level.
3. Measure the average power of the transmitter, and the average power is corrected with duty factor,  $10 \log(1/x)$ , where  $x$  is the duty cycle.

### 3.2.4 Test Setup

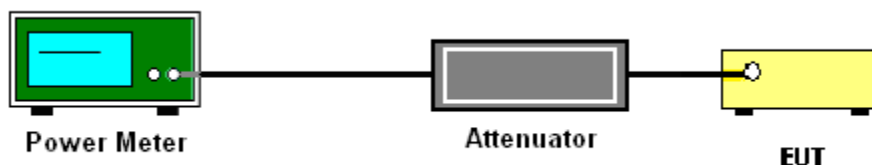

### 3.2.5 Test Result of Maximum Conducted Output Power

Please refer to Appendix A.



### 3.3 Power Spectral Density Measurement

#### 3.3.1 Limit of Power Spectral Density

For the band 5.725–5.85 GHz, the maximum power spectral density shall not exceed 30 dBm in any 500-kHz band.

If transmitting antennas of directional gain greater than 6 dBi are used, the peak output power shall be reduced by the amount in dB that the directional gain of the antenna exceeds 6 dBi.

#### 3.3.2 Measuring Instruments

The measuring equipment is listed in the section 4 of this test report.

#### 3.3.3 Test Procedures

The testing follows FCC KDB 789033 D02 General UNII Test Procedures New Rules v02r01. Section F) Maximum power spectral density.

##### # Method SA-2 #

(trace averaging across on and off times of the EUT transmissions, followed by duty cycle correction).

- Measure the duty cycle.
  - Set span to encompass the entire emission bandwidth (EBW) of the signal.
  - Set RBW = 300 kHz.
  - Set VBW  $\geq$  1 MHz.
  - Number of points in sweep  $\geq$  2 Span / RBW.
  - Sweep time = auto.
  - Detector = RMS
  - Trace average at least 100 traces in power averaging mode.
  - Add  $10 \log(500\text{kHz}/\text{RBW})$  to the test result.
  - Add  $10 \log(1/x)$ , where  $x$  is the duty cycle, to the measured power in order to compute the average power during the actual transmission times. For example, add  $10 \log(1/0.25) = 6$  dB if the duty cycle is 25 percent.
1. The RF output of EUT was connected to the spectrum analyzer by a low loss cable.
  2. Each plot has already offset with cable loss, and attenuator loss. Measure the PPSD and record it.



### 3.3.4 Test Setup

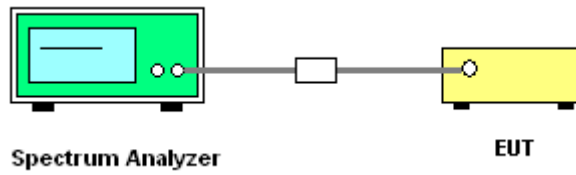

### 3.3.5 Test Result of Power Spectral Density

Please refer to Appendix A.

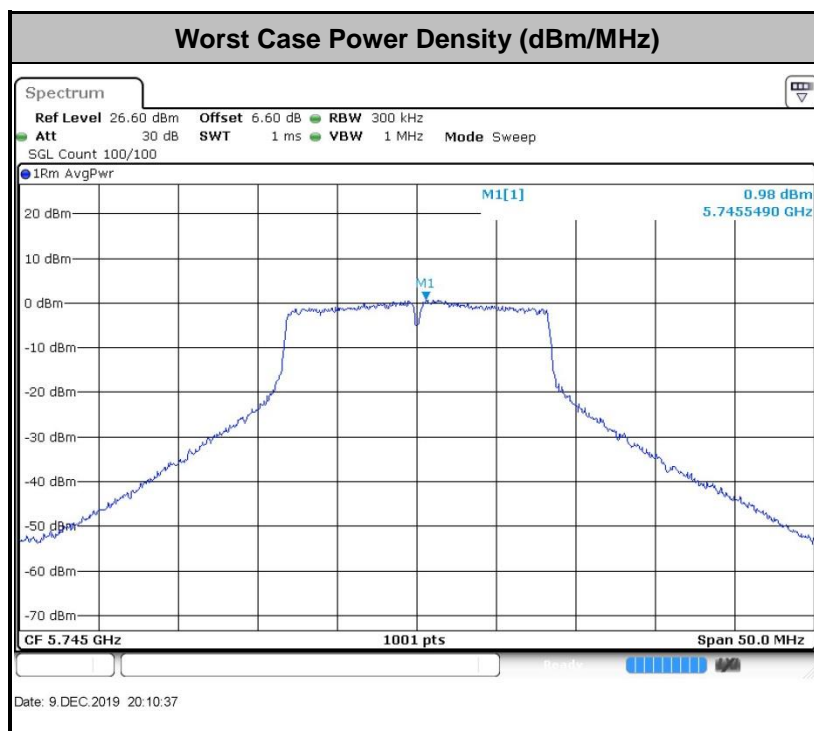

### 3.4 Unwanted Emissions Measurement

This section is to measure unwanted emissions through radiated measurement for band edge spurious emissions and out of band emissions measurement.

#### 3.4.1 Limit of Unwanted Emissions

- (1) For transmitters operating in the 5.725-5.85 GHz band:  
 15.407(b)(4)(i) All emissions shall be limited to a level of -27 dBm/MHz at 75 MHz or more above or below the band edge increasing linearly to 10 dBm/MHz at 25 MHz above or below the band edge, and from 25 MHz above or below the band edge increasing linearly to a level of 15.6 dBm/MHz at 5 MHz above or below the band edge, and from 5 MHz above or below the band edge increasing linearly to a level of 27 dBm/MHz at the band edge.
- (2) Unwanted spurious emissions fallen in restricted bands shall comply with the general field strength limits as below table,

Frequency (MHz)	Field Strength (microvolts/meter)	Measurement Distance (meters)
0.009 – 0.490	2400/F(kHz)	300
0.490 – 1.705	24000/F(kHz)	30
1.705 – 30.0	30	30
30 – 88	100	3
88 – 216	150	3
216 - 960	200	3
Above 960	500	3

EIRP (dBm)	Field Strength at 3m (dBµV/m)
- 27	68.2

**Note:** The following formula is used to convert the EIRP to field strength.

$$EIRP = E_{Meas} + 20\log (d_{Meas}) -104.7$$

where

EIRP is the equivalent isotropically radiated power, in dBm

$E_{Meas}$  is the field strength of the emission at the measurement distance, in dBµV/m

$d_{Meas}$  is the measurement distance, in m

#### 3.4.2 Measuring Instruments

The measuring equipment is listed in the section 4 of this test report.



### 3.4.3 Test Procedures

1. The testing follows FCC KDB 789033 D02 General UNII Test Procedures New Rules v02r01. Section G) Unwanted emissions measurement.
  - (1) Procedure for Unwanted Emissions Measurements Below 1000MHz
    - RBW = 120 kHz
    - VBW = 300 kHz
    - Detector = Peak
    - Trace mode = max hold
  - (2) Procedure for Peak Unwanted Emissions Measurements Above 1000 MHz
    - RBW = 1 MHz
    - VBW  $\geq$  3 MHz
    - Detector = Peak
    - Sweep time = auto
    - Trace mode = max hold
  - (3) Procedures for Average Unwanted Emissions Measurements Above 1000MHz
    - RBW = 1 MHz
    - VBW = 10 Hz, when duty cycle is no less than 98 percent.
    - VBW  $\geq$  1/T, when duty cycle is less than 98 percent where T is the minimum transmission duration over which the transmitter is on and is transmitting at its maximum power control level for the tested mode of operation.
2. The EUT was placed on a turntable with 0.8 meter for frequency below 1GHz and 1.5 meter for frequency above 1GHz respectively above ground.
3. The EUT was set 3 meters from the interference receiving antenna which was mounted on the top of a variable height antenna tower.
4. The antenna is a broadband antenna and its height is adjusted between one meter and four meters above ground to find the maximum value of the field strength for both horizontal polarization and vertical polarization of the antenna.
5. For each suspected emission, the EUT was arranged to its worst case and then adjust the antenna tower (from 1 m to 4 m) and turntable (from 0 degree to 360 degrees) to find the maximum reading.
6. For testing below 1GHz, if the emission level of the EUT in peak mode was 3 dB lower than the limit specified, then peak values of EUT will be reported, otherwise, the emissions will be repeated one by one using the CISPR quasi-peak method and reported.
7. For testing above 1GHz, the emission level of the EUT in peak mode was 20dB lower than average limit (that means the emission level in average mode also complies with the limit in average mode), then peak values of EUT will be reported, otherwise, the emissions will be measured in average mode again and reported.

### 3.4.4 Test Setup

For radiated emissions below 30MHz

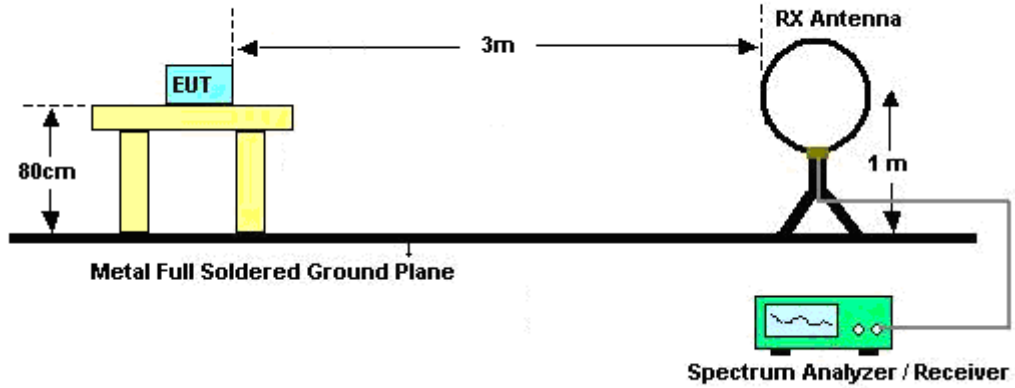

For radiated emissions from 30MHz to 1GHz

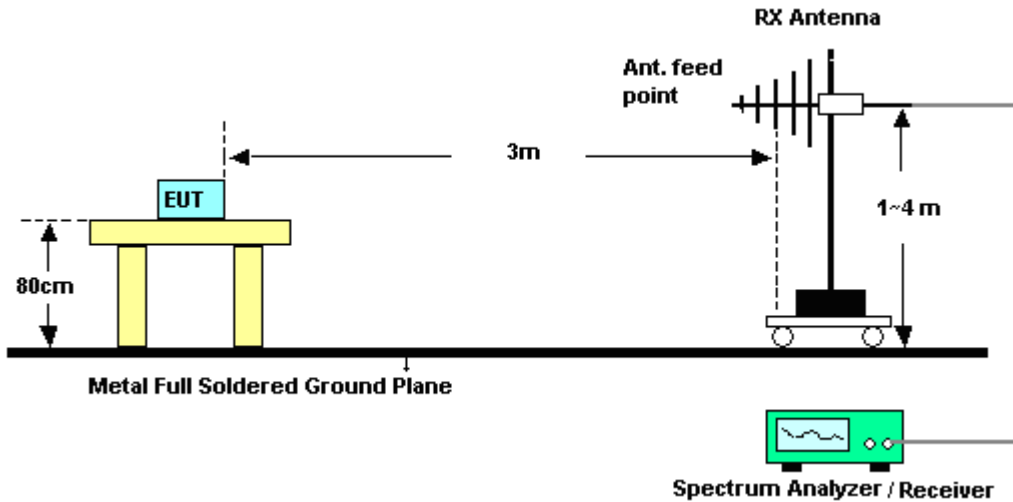

For radiated emissions above 1GHz

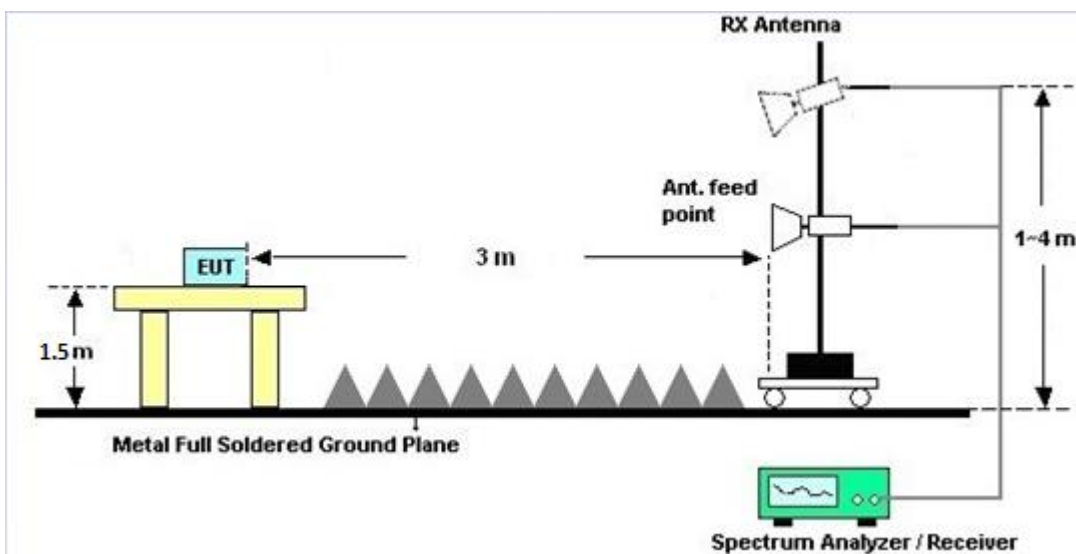



### **3.4.5 Test Results of Radiated Emissions (9 kHz ~ 30 MHz)**

The low frequency, which started from 9 kHz to 30MHz, was pre-scanned and the result which was 20dB lower than the limit line was not reported.

There is a comparison data of both open-field test site and semi-Anechoic chamber, and the result came out very similar.

### **3.4.6 Test Result of Radiated Band Edges**

Please refer to Appendix C.

### **3.4.7 Duty Cycle**

Please refer to Appendix D.

### **3.4.8 Test Result of Unwanted Radiated Emission (30MHz ~ 10th Harmonic)**

Please refer to Appendix C.



### 3.5 AC Conducted Emission Measurement

#### 3.5.1 Limit of AC Conducted Emission

For equipment that is designed to be connected to the public utility (AC) power line, the radio frequency voltage that is conducted back onto the AC power line on any frequency or frequencies within the band 150 kHz to 30 MHz shall not exceed the limits in the following table.

Frequency of emission (MHz)	Conducted limit (dBµV)	
	Quasi-peak	Average
0.15-0.5	66 to 56*	56 to 46*
0.5-5	56	46
5-30	60	50

\*Decreases with the logarithm of the frequency.

#### 3.5.2 Measuring Instruments

The measuring equipment is listed in the section 4 of this test report.

#### 3.5.3 Test Procedures

1. The EUT was placed 0.4 meter from the conducting wall of the shielding room was kept at least 80 centimeters from any other grounded conducting surface.
2. Connect EUT to the power mains through a line impedance stabilization network (LISN).
3. All the support units are connecting to the other LISN.
4. The LISN provides 50 ohm coupling impedance for the measuring instrument.
5. The FCC states that a 50 ohm, 50 microhenry LISN should be used.
6. Both sides of AC line were checked for maximum conducted interference.
7. The frequency range from 150 kHz to 30 MHz was searched.
8. Set the test-receiver system to Peak Detect Function and specified bandwidth with Maximum Hold Mode.

### 3.5.4 Test Setup

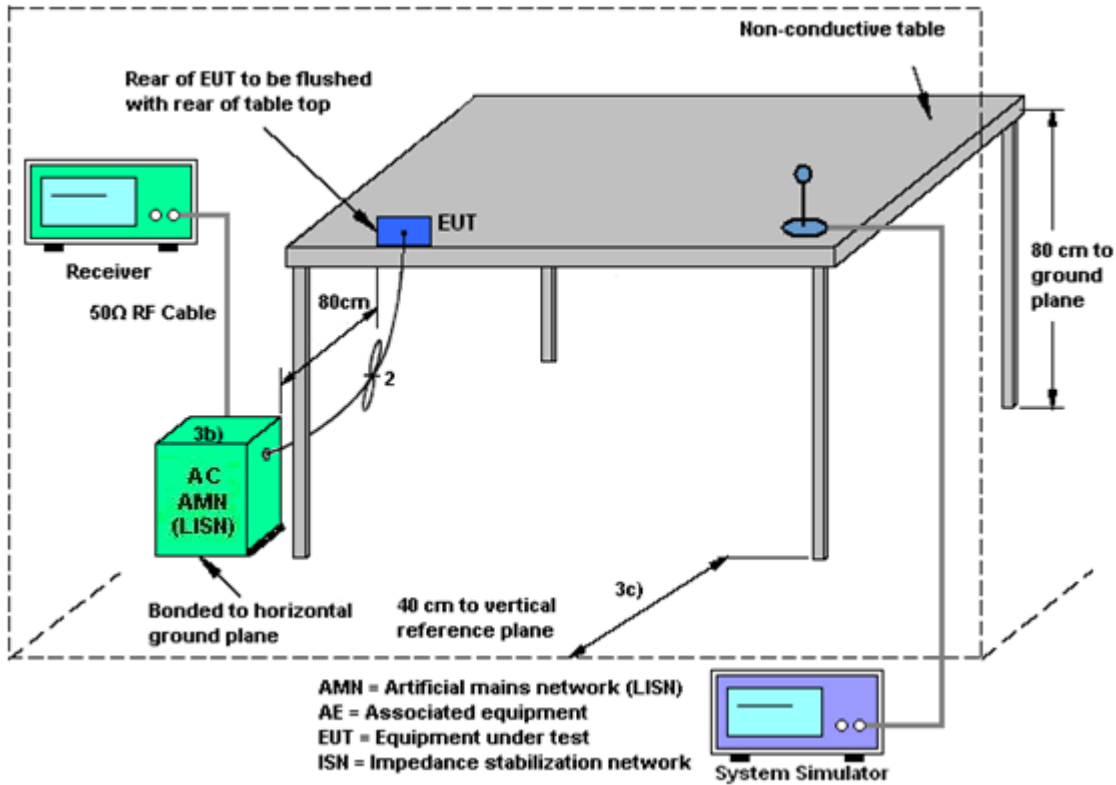

### 3.5.5 Test Result of AC Conducted Emission

Please refer to Appendix B.



## **3.6 Automatically Discontinue Transmission**

### **3.6.1 Limit of Automatically Discontinue Transmission**

The device shall automatically discontinue transmission in case of either absence of information to transmit or operational failure. These provisions are not intended to preclude the transmission of control or signaling information or the use of repetitive codes used by certain digital technologies to complete frame or burst intervals. Applicants shall include in their application for equipment authorization to describe how this requirement is met.

### **3.6.2 Measuring Instruments**

The measuring equipment is listed in the section 4 of this test report.

### **3.6.3 Test Result of Automatically Discontinue Transmission**

While the EUT is not transmitting any information, the EUT can automatically discontinue transmission and become standby mode for power saving. The EUT can detect the controlling signal of ACK message transmitting from remote device and verify whether it shall resend or discontinue transmission.





## 3.7 Antenna Requirements

### 3.7.1 Standard Applicable

If transmitting antenna directional gain is greater than 6 dBi, both the peak transmit power and the peak power spectral density shall be reduced by the amount in dB that the directional gain of the antenna exceeds 6 dBi.

### 3.7.2 Antenna Anti-Replacement Construction

An embedded-in antenna design is used.

### 3.7.3 Antenna Gain

The antenna peak gain of EUT is less than 6 dBi. Therefore, it is not necessary to reduce maximum peak output power limit.



## 4 List of Measuring Equipment

Instrument	Manufacturer	Model No.	Serial No.	Characteristics	Calibration Date	Test Date	Due Date	Remark
Spectrum Analyzer	R&S	FSV40	101040	10Hz~40GHz	Nov. 02, 2019	Dec. 09, 2019	Nov. 01, 2020	Conducted (TH01-KS)
Pulse Power Sensor	Anritsu	MA2411B	0917070	300MHz~40GHz	Jan. 14, 2019	Dec. 09, 2019	Jan. 13, 2020	Conducted (TH01-KS)
Power Meter	Anritsu	ML2495A	1005002	50MHz Bandwidth	Jan. 14, 2019	Dec. 09, 2019	Jan. 13, 2020	Conducted (TH01-KS)
EMI Test Receiver	Keysight	N9038A	MY57290157	3Hz~8.5GHz;Max 30dBm	Jul. 18, 2019	Jan. 08, 2020	Jul. 17, 2020	Radiation (03CH06-KS)
EXA Spectrum Analyzer	Keysight	N9010A	MY55150208	10Hz~44GHz	Apr. 16, 2019	Jan. 08, 2020	Apr. 18, 2020	Radiation (03CH06-KS)
Loop Antenna	R&S	HFH2-Z2	100321	9kHz~30MHz	Nov. 10, 2019	Jan. 08, 2020	Nov. 09, 2020	Radiation (03CH06-KS)
Bilog Antenna	TeseQ	CBL6111D	49921	30MHz~1GHz	May 30, 2019	Jan. 08, 2020	May 29, 2020	Radiation (03CH06-KS)
Double Ridge Horn Antenna	ETS-Lindgren	3117	75959	1GHz~18GHz	Jan. 27, 2019	Jan. 08, 2020	Jan. 26, 2020	Radiation (03CH06-KS)
SHF-EHF Horn	Com-power	AH-840	101070	18GHz~40GHz	Jan. 08, 2020	Jan. 08, 2020	Jan. 07, 2021	Radiation (03CH06-KS)
Amplifier	SONOMA	310N	187289	9KHz ~1GHZ	Aug. 06, 2019	Jan. 08, 2020	Aug. 05, 2020	Radiation (03CH06-KS)
Amplifier	MITEQ	TTA1840-35-HG	2014749	18~40GHz	Jan. 14, 2019	Jan. 08, 2020	Jan. 13, 2020	Radiation (03CH06-KS)
high gain Amplifier	MITEQ	AMF-7D-0010 1800-30-10P	2025788	1Ghz-18Ghz	Aug. 16, 2019	Jan. 08, 2020	Aug. 15, 2020	Radiation (03CH06-KS)
Amplifier	Keysight	83017A	MY53270203	500MHz~26.5GHz	Apr. 15, 2019	Jan. 08, 2020	Apr. 14, 2020	Radiation (03CH06-KS)
AC Power Source	Chroma	61601	F104090004	N/A	NCR	Jan. 08, 2020	NCR	Radiation (03CH06-KS)
Turn Table	ChamPro	EM 1000-T	060762-T	0~360 degree	NCR	Jan. 08, 2020	NCR	Radiation (03CH06-KS)
Antenna Mast	ChamPro	EM 1000-A	060762-A	1 m~4 m	NCR	Jan. 08, 2020	NCR	Radiation (03CH06-KS)
EMI Receiver	R&S	ESCI7	100768	9kHz~7GHz;	Apr. 16, 2019	Jan. 23, 2020	Apr. 15, 2020	Conduction (CO01-KS)
AC LISN (for auxiliary equipment)	MessTec	AN3016	060103	9kHz~30MHz	Oct. 18, 2019	Jan. 23, 2020	Oct. 17, 2020	Conduction (CO01-KS)
AC LISN	MessTec	AN3016	060105	9kHz~30MHz	Oct. 28, 2019	Jan. 23, 2020	Oct. 27, 2020	Conduction (CO01-KS)
AC Power Source	Chroma	61602	ABP00000811	AC 0V~300V, 45Hz~1000Hz	Oct. 18, 2019	Jan. 23, 2020	Oct. 17, 2020	Conduction (CO01-KS)

NCR: No Calibration Required



## 5 Uncertainty of Evaluation

The measurement uncertainties shown below were calculated in accordance with the requirements of ANSI 63.10-2013. All the measurement uncertainty value were shown with a coverage K=2 to indicate 95% level of confidence. The measurement data show herein meets or exceeds the CISPR measurement uncertainty values specified in CISPR 16-4-2 and can be compared directly to specified limit to determine compliance.

### Uncertainty of Conducted Emission Measurement (150kHz ~ 30MHz)

Measuring Uncertainty for a Level of Confidence of 95% (U = 2Uc(y))	2.9dB
---	-------

### Uncertainty of Radiated Emission Measurement (30 MHz ~ 1000 MHz)

Measuring Uncertainty for a Level of Confidence of 95% (U = 2Uc(y))	5.0dB
---	-------

### Uncertainty of Radiated Emission Measurement (1000 MHz ~ 18000 MHz)

Measuring Uncertainty for a Level of Confidence of 95% (U = 2Uc(y))	5.0dB
---	-------

### Uncertainty of Radiated Emission Measurement (18000 MHz ~ 40000 MHz)

Measuring Uncertainty for a Level of Confidence of 95% (U = 2Uc(y))	5.0dB
---	-------



## **Appendix A. Conducted Test Results**

Report Number : FR9O1409F

Test Engineer:	Weller Liu	Temperature:	21~25	°C
Test Date:	2019/12/9	Relative Humidity:	51~54	%

**TEST RESULTS DATA**  
**6dB and 26dB EBW and 99% OBW**

Band IV									
Mod.	Data Rate	N <sub>Tx</sub>	CH.	Freq. (MHz)	99% Bandwidth (MHz)	26 dB Bandwidth (MHz)	6 dB Bandwidth (MHz)	6dB Bandwidth min. Limit (MHz)	Pass/Fail
11a	6M bps	1	149	5745	17.68	24.48	15.92	0.5	Pass
11a	6Mbps	1	157	5785	17.68	24.28	15.90	0.5	Pass
11a	6Mbps	1	165	5825	17.68	24.03	16.28	0.5	Pass
HT20	MCS 0	1	149	5745	18.88	25.48	16.40	0.5	Pass
HT20	MCS 0	1	157	5785	18.83	25.38	16.50	0.5	Pass
HT20	MCS 0	1	165	5825	18.88	25.28	16.26	0.5	Pass
HT40	MCS 0	1	151	5755	36.46	41.99	35.68	0.5	Pass
HT40	MCS 0	1	159	5795	36.66	42.08	35.64	0.5	Pass

**TEST RESULTS DATA**  
**Average Power Table**

Band IV										
Mod.	Data Rate	N <sub>Tx</sub>	CH.	Freq. (MHz)	Duty Factor (dB)	Average Conducted Power (dBm)	FCC Conducted Power Limit (dBm)	DG (dBi)		Pass/Fail
11a	6M bps	1	149	5745	0.21	15.76	30.00	-1.00		Pass
11a	6Mbps	1	157	5785	0.21	16.07	30.00	-1.00		Pass
11a	6Mbps	1	165	5825	0.21	16.04	30.00	-1.00		Pass
HT20	MCS 0	1	149	5745	0.20	15.54	30.00	-1.00		Pass
HT20	MCS 0	1	157	5785	0.20	15.98	30.00	-1.00		Pass
HT20	MCS 0	1	165	5825	0.20	15.88	30.00	-1.00		Pass
HT40	MCS 0	1	151	5755	0.42	16.33	30.00	-1.00		Pass
HT40	MCS 0	1	159	5795	0.42	16.48	30.00	-1.00		Pass
VHT20	MCS 0	1	149	5745	0.23	15.60	30.00	-1.00		Pass
VHT20	MCS 0	1	157	5785	0.23	15.85	30.00	-1.00		Pass
VHT20	MCS 0	1	165	5825	0.23	15.91	30.00	-1.00		Pass
VHT40	MCS 0	1	151	5755	0.42	16.29	30.00	-1.00		Pass
VHT40	MCS 0	1	159	5795	0.42	16.36	30.00	-1.00		Pass

***TEST RESULTS DATA***  
***Power Spectral Density***

Band IV										
Mod.	Data Rate	N <sub>TX</sub>	CH.	Freq. (MHz)	Duty Factor (dB)	10log (500kHz /RBW) Factor (dB)	Average Power Density (dBm/500kHz)	Average PSD Limit (dBm/500kHz)	DG (dBi)	Pass/Fail
11a	6M bps	1	149	5745	0.21	2.22	3.41	30.00	-1.00	Pass
11a	6Mbps	1	157	5785	0.21	2.22	3.30	30.00	-1.00	Pass
11a	6Mbps	1	165	5825	0.21	2.22	3.16	30.00	-1.00	Pass
HT20	MCS 0	1	149	5745	0.20	2.22	2.97	30.00	-1.00	Pass
HT20	MCS 0	1	157	5785	0.20	2.22	3.01	30.00	-1.00	Pass
HT20	MCS 0	1	165	5825	0.20	2.22	2.39	30.00	-1.00	Pass
HT40	MCS 0	1	151	5755	0.42	2.22	0.02	30.00	-1.00	Pass
HT40	MCS 0	1	159	5795	0.42	2.22	0.46	30.00	-1.00	Pass





## Appendix B. AC Conducted Emission Test Results

Test Engineer :	Amos Zhang	Temperature :	25.3~26.2°C
		Relative Humidity :	38~40%
Test Voltage :	120Vac / 60Hz	Phase :	Line
Remark :	All emissions not reported here are more than 10 dB below the prescribed limit.		

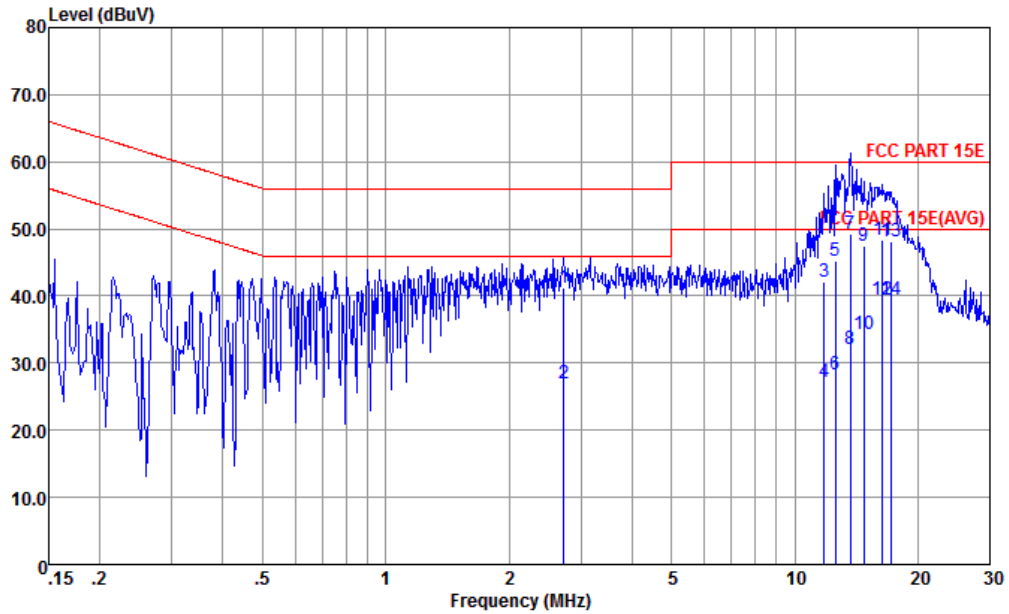

Site : CO01-KS  
 Condition : FCC PART 15E LISN-L-191028-060105 LINE

	Freq	Level	Over	Limit	Read	LISN	Cable	Remark
	MHz	dBuV	Limit	Line	Level	Factor	Loss	
			dB	dBuV	dBuV	dB	dB	
1	2.721	41.26	-14.74	56.00	30.90	0.12	10.24	QP
2	2.721	26.96	-19.04	46.00	16.60	0.12	10.24	Average
3	11.807	42.16	-17.84	60.00	31.50	0.30	10.36	QP
4	11.807	27.26	-22.74	50.00	16.60	0.30	10.36	Average
5	12.582	45.29	-14.71	60.00	34.60	0.32	10.37	QP
6	12.582	28.29	-21.71	50.00	17.60	0.32	10.37	Average
7	13.695	49.33	-10.67	60.00	38.60	0.35	10.38	QP
8	13.695	32.03	-17.97	50.00	21.30	0.35	10.38	Average
9	14.750	47.56	-12.44	60.00	36.80	0.37	10.39	QP
10	14.750	34.36	-15.64	50.00	23.60	0.37	10.39	Average
11	16.398	48.39	-11.61	60.00	37.50	0.46	10.43	QP
12	16.398	39.39	-10.61	50.00	28.50	0.46	10.43	Average
13	17.199	48.04	-11.96	60.00	37.10	0.50	10.44	QP
14 *	17.199	39.54	-10.46	50.00	28.60	0.50	10.44	Average



Test Engineer :	Amos Zhang	Temperature :	25.3~26.2°C
		Relative Humidity :	38~40%
Test Voltage :	120Vac / 60Hz	Phase :	Neutral
Remark :	All emissions not reported here are more than 10 dB below the prescribed limit.		

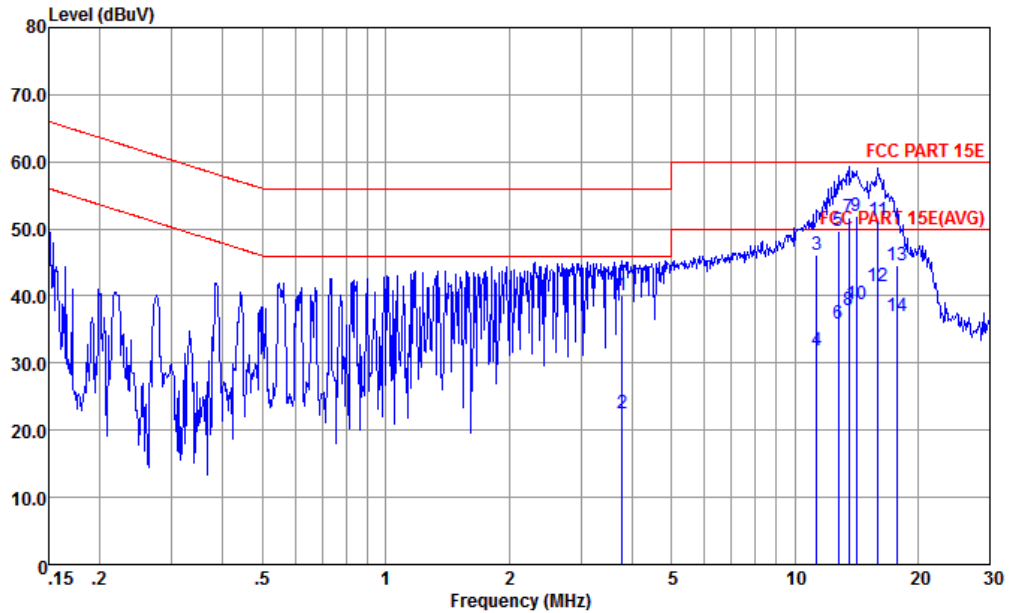

Site : CO01-KS  
 Condition : FCC PART 15E LISN-N-191028-060105 NEUTRAL

	Freq	Level	Over	Limit	Read	LISN	Cable	Remark
	MHz	dBuV	Limit	Line	Level	Factor	Loss	
			dB	dBuV	dBuV	dB	dB	
1	3.779	40.00	-16.00	56.00	29.60	0.15	10.25	QP
2	3.779	22.60	-23.40	46.00	12.20	0.15	10.25	Average
3	11.317	46.15	-13.85	60.00	35.50	0.29	10.36	QP
4	11.317	31.95	-18.05	50.00	21.30	0.29	10.36	Average
5	12.784	49.60	-10.40	60.00	38.90	0.33	10.37	QP
6	12.784	35.90	-14.10	50.00	25.20	0.33	10.37	Average
7	13.551	51.63	-8.37	60.00	40.90	0.35	10.38	QP
8	13.551	37.93	-12.07	50.00	27.20	0.35	10.38	Average
9 *	14.138	51.85	-8.15	60.00	41.10	0.36	10.39	QP
10	14.138	38.85	-11.15	50.00	28.10	0.36	10.39	Average
11	15.970	51.35	-8.65	60.00	40.50	0.43	10.42	QP
12	15.970	41.45	-8.55	50.00	30.60	0.43	10.42	Average
13	17.849	44.58	-15.42	60.00	33.60	0.53	10.45	QP
14	17.849	36.88	-13.12	50.00	25.90	0.53	10.45	Average

Note:

- Level(dBμV) = Read Level(dBμV) + LISN Factor(dB) + Cable Loss(dB)
- Over Limit(dB) = Level(dBμV) – Limit Line(dBμV)



## Appendix C. Radiated Spurious Emission

### Band 4 - 5725~5850MHz WIFI 802.11a (Band Edge @ 3m)

WIFI Ant.	Note	Frequency	Level	Over Limit	Limit Line	Read Level	Antenna Factor	Cable Loss	Preamp Factor	Ant Pos	Table Pos	Peak Avg.	Pol.
1		( MHz )	( dBμV/m )	( dB )	( dBμV/m )	( dBμV )	( dB/m )	( dB )	( dB )	( cm )	( deg )	( P/A )	( H/V )
802.11a CH 149 5745MHz		5646.4	56.98	-11.32	68.3	41.08	34.67	11.42	30.19	103	50	P	H
		5664.8	56.89	-22.4	79.29	40.95	34.7	11.45	30.21	103	50	P	H
		5709.6	60.1	-47.89	107.99	44.06	34.73	11.55	30.24	103	50	P	H
		5724.8	63.55	-58.29	121.84	47.44	34.77	11.58	30.24	103	50	P	H
		5746	107.96	-	-	91.81	34.8	11.61	30.26	103	50	P	H
		5746	101.04	-	-	84.89	34.8	11.61	30.26	103	50	A	H
		5630.4	55.61	-12.69	68.3	39.77	34.63	11.4	30.19	349	282	P	V
		5653.2	56.49	-14.19	70.68	40.53	34.7	11.45	30.19	349	282	P	V
		5712.8	57.76	-51.13	108.89	41.72	34.73	11.55	30.24	349	282	P	V
		5724.4	64.22	-56.71	120.93	48.11	34.77	11.58	30.24	349	282	P	V
		5746	107.88	-	-	91.73	34.8	11.61	30.26	349	282	P	V
		5746	100.86	-	-	84.71	34.8	11.61	30.26	349	282	A	V
802.11a CH 165 5825MHz		5853.6	62.56	-52.37	114.93	46.04	35.03	11.82	30.33	101	49	P	H
		5860.8	62.3	-46.97	109.27	45.79	35.03	11.82	30.34	101	49	P	H
		5875.6	56.56	-48.29	104.85	39.99	35.07	11.84	30.34	101	49	P	H
		5942	56.88	-11.42	68.3	40.17	35.2	11.9	30.39	101	49	P	H
		5824	107.83	-	-	91.41	34.97	11.76	30.31	101	49	P	H
		5824	100.52	-	-	84.1	34.97	11.76	30.31	101	49	A	H
		5851.6	57.32	-63.37	120.69	40.86	35	11.79	30.33	374	284	P	V
		5855.6	56.68	-54.05	110.73	40.16	35.03	11.82	30.33	374	284	P	V
		5887.2	57.73	-38.51	96.24	41.18	35.07	11.84	30.36	374	284	P	V
		5958.8	56.45	-11.85	68.3	39.7	35.23	11.91	30.39	374	284	P	V
		5824	107.95	-	-	91.53	34.97	11.76	30.31	374	284	P	V
		5824	100.63	-	-	84.21	34.97	11.76	30.31	374	284	A	V
Remark	1. No other spurious found. 2. All results are PASS against Peak and Average limit line.												



Band 4 5725~5850MHz

WIFI 802.11a (Harmonic @ 3m)

WIFI Ant. 1	Note	Frequency ( MHz )	Level ( dBμV/m )	Over Limit ( dB )	Limit Line ( dBμV/m )	Read Level ( dBμV )	Antenna Factor ( dB/m )	Cable Loss ( dB )	Preamp Factor ( dB )	Ant Pos ( cm )	Table Pos ( deg )	Peak Avg. ( P/A )	Pol. ( H/V )
802.11a CH 149		11490	40.74	-33.26	74	49.48	38.08	16.03	62.85	100	360	P	H
5745MHz		11490	39.68	-34.32	74	48.42	38.08	16.03	62.85	100	360	P	V
802.11a CH 157		11570	41.1	-32.9	74	49.56	38.17	16.11	62.74	100	360	P	H
5785MHz		11570	38.95	-35.05	74	47.41	38.17	16.11	62.74	100	341	P	V
802.11a CH 165		11650	42.81	-31.19	74	51.01	38.24	16.18	62.62	100	360	P	H
5825MHz		11650	43.07	-30.93	74	51.27	38.24	16.18	62.62	100	360	P	V
Remark	1. No other spurious found. 2. All results are PASS against Peak and Average limit line.												



Band 4 5725~5850MHz

WIFI 802.11n HT20 (Band Edge @ 3m)

WIFI Ant. 1	Note	Frequency ( MHz )	Level ( dBμV/m )	Over Limit ( dB )	Limit Line ( dBμV/m )	Read Level ( dBμV )	Antenna Factor ( dB/m )	Cable Loss ( dB )	Preamp Factor ( dB )	Ant Pos ( cm )	Table Pos ( deg )	Peak Avg. ( P/A )	Pol. ( H/V )
802.11n HT20 CH 149 5745MHz		5649.8	56.46	-11.84	68.3	40.5	34.7	11.45	30.19	103	43	P	H
		5650.8	56.48	-12.41	68.89	40.52	34.7	11.45	30.19	103	43	P	H
		5713.6	59.38	-49.73	109.11	43.34	34.73	11.55	30.24	103	43	P	H
		5724.8	63.13	-58.71	121.84	47.02	34.77	11.58	30.24	103	43	P	H
		5746	107.02	-	-	90.87	34.8	11.61	30.26	103	43	P	H
		5746	99.34	-	-	83.19	34.8	11.61	30.26	103	43	A	H
		5646	56.49	-11.81	68.3	40.59	34.67	11.42	30.19	296	319	P	V
		5693.6	57.03	-43.55	100.58	41.04	34.7	11.52	30.23	296	319	P	V
		5706.4	60.49	-46.6	107.09	44.45	34.73	11.55	30.24	296	319	P	V
		5724.4	62.07	-58.86	120.93	45.96	34.77	11.58	30.24	296	319	P	V
		5746	106.06	-	-	89.91	34.8	11.61	30.26	296	319	P	V
		5746	99.35	-	-	83.2	34.8	11.61	30.26	296	319	A	V
802.11n HT20 CH 165 5825MHz		5850	61.64	-63.66	125.3	45.18	35	11.79	30.33	100	43	P	H
		5864	60.57	-47.81	108.38	44.06	35.03	11.82	30.34	100	43	P	H
		5904.4	58.07	-25.44	83.51	41.48	35.1	11.85	30.36	100	43	P	H
		5995.6	57.04	-11.26	68.3	40.22	35.3	11.94	30.42	100	43	P	H
		5824	106.55	-	-	90.13	34.97	11.76	30.31	100	43	P	H
		5824	99.78	-	-	83.36	34.97	11.76	30.31	100	43	A	H
		5854.8	62.38	-49.1	111.48	45.86	35.03	11.82	30.33	332	301	P	V
		5855.2	62.38	-48.46	110.84	45.86	35.03	11.82	30.33	332	301	P	V
		5884	56.48	-42.14	98.62	39.93	35.07	11.84	30.36	332	301	P	V
		5975.6	56.71	-11.59	68.3	39.91	35.27	11.93	30.4	332	301	P	V
Remark	1. No other spurious found.												
	2. All results are PASS against Peak and Average limit line.												



**Band 4 5725~5850MHz**  
**WIFI 802.11n HT20 (Harmonic @ 3m)**

WIFI Ant. 1	Note	Frequency ( MHz )	Level ( dBμV/m )	Over Limit ( dB )	Limit Line ( dBμV/m )	Read Level ( dBμV )	Antenna Factor ( dB/m )	Cable Loss ( dB )	Preamp Factor ( dB )	Ant Pos ( cm )	Table Pos ( deg )	Peak Avg. ( P/A )	Pol. ( H/V )
802.11n HT20		11490	40.82	-33.18	74	49.56	38.08	16.03	62.85	100	360	P	H
CH 149		11490	40.63	-33.37	74	49.37	38.08	16.03	62.85	100	105	P	V
5745MHz													
802.11n HT20		11570	41.11	-32.89	74	49.57	38.17	16.11	62.74	100	360	P	H
CH 157		11570	41.66	-32.34	74	50.12	38.17	16.11	62.74	100	360	P	V
5785MHz													
802.11n HT20		11650	41.7	-32.3	74	49.9	38.24	16.18	62.62	100	360	P	H
CH 165		11650	40.57	-33.43	74	48.77	38.24	16.18	62.62	100	360	P	V
5825MHz													
Remark	1. No other spurious found. 2. All results are PASS against Peak and Average limit line.												



Band 4 5725~5850MHz

WIFI 802.11n HT40 (Band Edge @ 3m)

WIFI Ant. 1	Note	Frequency ( MHz )	Level ( dBμV/m )	Over Limit ( dB )	Limit Line ( dBμV/m )	Read Level ( dBμV )	Antenna Factor ( dB/m )	Cable Loss ( dB )	Preamp Factor ( dB )	Ant Pos ( cm )	Table Pos ( deg )	Peak Avg. ( P/A )	Pol. ( H/V )
802.11n HT40 CH 151 5755MHz		5645.2	55.97	-12.33	68.3	40.07	34.67	11.42	30.19	115	49	P	H
		5698	57.19	-46.64	103.83	41.2	34.7	11.52	30.23	115	49	P	H
		5717.2	69.42	-40.7	110.12	53.38	34.73	11.55	30.24	115	49	P	H
		5724.8	69.14	-52.7	121.84	53.03	34.77	11.58	30.24	115	49	P	H
		5850	54.74	-70.56	125.3	38.28	35	11.79	30.33	115	49	P	H
		5866.4	55.95	-51.76	107.71	39.44	35.03	11.82	30.34	115	49	P	H
		5914.8	56.24	-19.58	75.82	39.61	35.13	11.87	30.37	115	49	P	H
		5958	56.68	-11.62	68.3	39.93	35.23	11.91	30.39	115	49	P	H
		5758	104.51	-	-	88.32	34.83	11.64	30.28	115	49	P	H
		5758	97.25	-	-	81.06	34.83	11.64	30.28	115	49	A	H
		5640	56.61	-11.69	68.3	40.71	34.67	11.42	30.19	364	253	P	V
		5698.4	56.65	-47.47	104.12	40.66	34.7	11.52	30.23	364	253	P	V
		5719.6	68.3	-42.49	110.79	52.19	34.77	11.58	30.24	364	253	P	V
		5724.8	69.56	-52.28	121.84	53.45	34.77	11.58	30.24	364	253	P	V
		5854.4	55.76	-56.87	112.63	39.24	35.03	11.82	30.33	364	253	P	V
		5861.6	55.96	-53.09	109.05	39.45	35.03	11.82	30.34	364	253	P	V
		5875.6	56.76	-48.09	104.85	40.19	35.07	11.84	30.34	364	253	P	V
		5994.8	56.2	-12.1	68.3	39.38	35.3	11.94	30.42	364	253	P	V
	5752	104.22	-	-	88.01	34.83	11.64	30.26	364	253	P	V	
	5752	97.2	-	-	80.99	34.83	11.64	30.26	364	253	A	V	



WIFI Ant. 1	Note	Frequency ( MHz )	Level ( dBμV/m )	Over Limit ( dB )	Limit Line ( dBμV/m )	Read Level ( dBμV )	Antenna Factor ( dB/m )	Cable Loss ( dB )	Preamp Factor ( dB )	Ant Pos ( cm )	Table Pos ( deg )	Peak Avg. ( P/A )	Pol. ( H/V )
802.11n HT40 CH 159 5795MHz		5602.4	56.12	-12.18	68.3	40.35	34.6	11.39	30.22	179	8	P	H
		5657.2	55.83	-17.82	73.65	39.89	34.7	11.45	30.21	179	8	P	H
		5718.8	56.94	-53.62	110.56	40.83	34.77	11.58	30.24	179	8	P	H
		5720.8	55.69	-57.03	112.72	39.58	34.77	11.58	30.24	179	8	P	H
		5852.4	57.54	-60.85	118.39	41.08	35	11.79	30.33	179	8	P	H
		5866.8	60.45	-47.14	107.59	43.94	35.03	11.82	30.34	179	8	P	H
		5876	57.87	-46.69	104.56	41.3	35.07	11.84	30.34	179	8	P	H
		5939.2	55.79	-12.51	68.3	39.08	35.2	11.9	30.39	179	8	P	H
		5794	106.05	-	-	89.75	34.9	11.7	30.3	179	8	P	H
		5794	98.59	-	-	82.29	34.9	11.7	30.3	179	8	A	H
		5640.8	55.8	-12.5	68.3	39.9	34.67	11.42	30.19	291	298	P	V
		5670	57	-26.14	83.14	41.03	34.7	11.48	30.21	291	298	P	V
		5708	56.31	-51.23	107.54	40.27	34.73	11.55	30.24	291	298	P	V
		5721.6	56.13	-58.42	114.55	40.02	34.77	11.58	30.24	291	298	P	V
		5851.2	57.83	-64.01	121.84	41.37	35	11.79	30.33	291	298	P	V
		5856.8	61.03	-49.37	110.4	44.51	35.03	11.82	30.33	291	298	P	V
		5901.2	56.24	-29.63	85.87	39.65	35.1	11.85	30.36	291	298	P	V
		5947.6	56.42	-11.88	68.3	39.71	35.2	11.9	30.39	291	298	P	V
		5794	104.53	-	-	88.23	34.9	11.7	30.3	291	298	P	V
	5794	97.14	-	-	80.84	34.9	11.7	30.3	291	298	A	V	
Remark	1. No other spurious found. 2. All results are PASS against Peak and Average limit line.												





Band 4 5725~5850MHz
WIFI 802.11n HT40 (Harmonic @ 3m)

Table with 14 columns: WIFI Ant. 1, Note, Frequency (MHz), Level (dBµV/m), Over Limit (dB), Limit Line (dBµV/m), Read Level (dBµV), Antenna Factor (dB/m), Cable Loss (dB), Preamp Factor (dB), Ant Pos (cm), Table Pos (deg), Peak Avg. (P/A), Pol. (H/V). Rows include test results for 802.11n HT40 CH 151 and CH 159 at 11510MHz and 11590MHz.



Band 4 5725~5850MHz

Emission below 1GHz

5GHz WIFI 802.11n HT20 (LF @ 3m)

WIFI Ant.	Note	Frequency	Level	Over Limit	Limit Line	Read Level	Antenna Factor	Cable Loss	Preamp Factor	Ant Pos	Table Pos	Peak Avg.	Pol.
1		( MHz )	( dBμV/m )	( dB )	( dBμV/m )	( dBμV )	( dB/m )	( dB )	( dB )	( cm )	( deg )	( P/A )	( H/V )
5GHz 802.11n HT20 LF		54.25	19.38	-20.62	40	37.72	13.34	1.28	32.96	-	-	P	H
		100.81	28.13	-15.37	43.5	42.45	16.96	1.64	32.92	-	-	P	H
		204.6	32.08	-11.42	43.5	47.21	15.53	2.26	32.92	-	-	P	H
		244.37	35.43	-10.57	46	47.98	17.97	2.46	32.98	100	0	P	H
		312.27	29.84	-16.16	46	40.59	19.52	2.77	33.04	-	-	P	H
		359.8	26.97	-19.03	46	36.43	20.7	2.94	33.1	-	-	P	H
		43.58	28.15	-11.85	40	43.26	16.7	1.16	32.97	-	-	P	V
		76.56	31.6	-8.4	40	50.36	12.7	1.46	32.92	100	360	P	V
		130.88	30.51	-12.99	43.5	43.91	17.7	1.84	32.94	-	-	P	V
		199.75	33.32	-10.18	43.5	48.4	15.6	2.23	32.91	-	-	P	V
		239.52	27.23	-18.77	46	40.37	17.4	2.43	32.97	-	-	P	V
	366.59	21.82	-24.18	46	31.08	20.87	2.97	33.1	-	-	P	V	
Remark	1. No other spurious found. 2. All results are PASS against limit line.												



**Note symbol**

*	<b>Fundamental Frequency</b> which can be ignored. However, the level of any unwanted emissions shall not exceed the level of the fundamental frequency.
!	Test result is <b>over limit</b> line.
P/A	<b>Peak</b> or <b>Average</b>
H/V	<b>Horizontal</b> or <b>Vertical</b>



A calculation example for radiated spurious emission is shown as below:

WIFI	Note	Frequency	Level	Over	Limit	Read	Antenna	Cable	Preamp	Ant	Table	Peak	Pol.
Ant.				Limit	Line	Level	Factor	Loss	Factor	Pos	Pos	Avg.	
2		( MHz )	( dBμV/m )	( dB )	( dBμV/m )	( dBμV )	( dB/m )	( dB )	( dB )	( cm )	( deg )	( P/A )	( H/V )
802.11b		2390	55.45	-18.55	74	54.51	32.22	4.58	35.86	103	308	P	H
CH 01													
2412MHz		2390	43.54	-10.46	54	42.6	32.22	4.58	35.86	103	308	A	H

- Level(dBμV/m) =  
Antenna Factor(dB/m) + Cable Loss(dB) + Read Level(dBμV) - Preamp Factor(dB)
- Over Limit(dB) = Level(dBμV/m) – Limit Line(dBμV/m)

**For Peak Limit @ 2390MHz:**

- Level(dBμV/m)  
= Antenna Factor(dB/m) + Cable Loss(dB) + Read Level(dBμV) - Preamp Factor(dB)  
= 32.22(dB/m) + 4.58(dB) + 54.51(dBμV) – 35.86 (dB)  
= 55.45 (dBμV/m)
- Over Limit(dB)  
= Level(dBμV/m) – Limit Line(dBμV/m)  
= 55.45(dBμV/m) – 74(dBμV/m)  
= -18.55(dB)

**For Average Limit @ 2390MHz:**

- Level(dBμV/m)  
= Antenna Factor(dB/m) + Cable Loss(dB) + Read Level(dBμV) - Preamp Factor(dB)  
= 32.22(dB/m) + 4.58(dB) + 42.6(dBμV) – 35.86 (dB)  
= 43.54 (dBμV/m)
- Over Limit(dB)  
= Level(dBμV/m) – Limit Line(dBμV/m)  
= 43.54(dBμV/m) – 54(dBμV/m)  
= -10.46(dB)

Both peak and average measured complies with the limit line, so test result is “PASS”.



## Appendix D. Duty Cycle Plots

Band	Duty Cycle(%)	T(ms)	1/T(kHz)	VBW Setting
802.11a	95.24	2.029	0.493	0.51kHz
802.11n HT20	95.60	1.891	0.529	0.56kHz
802.11n HT40	90.78	0.928	1.078	1.1kHz

### 802.11a

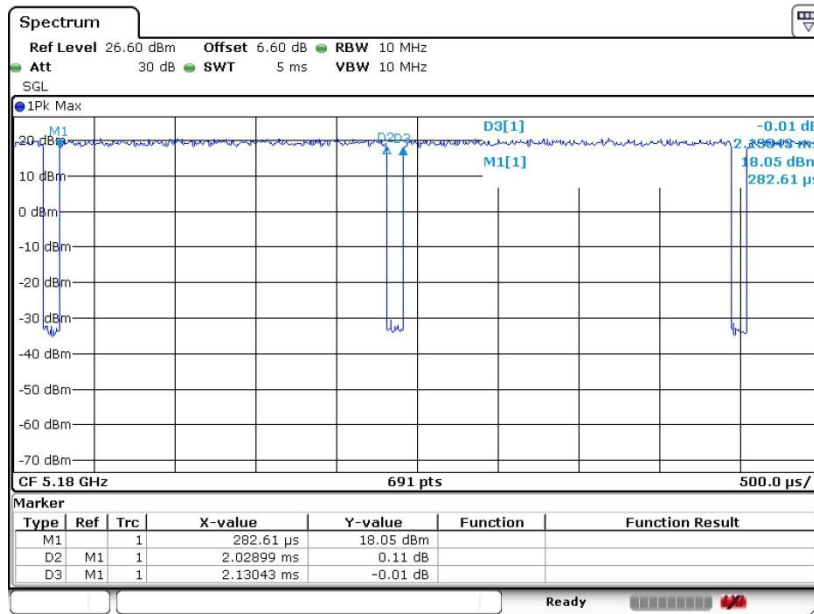

Date: 2.DEC.2019 11:10:28



802.11n HT20

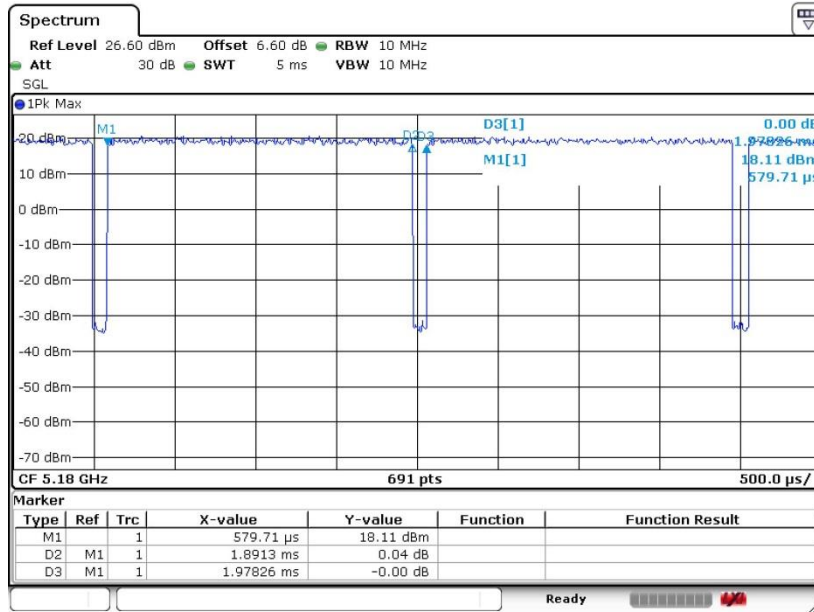

Date: 2.DEC.2019 11:11:24

802.11n HT40

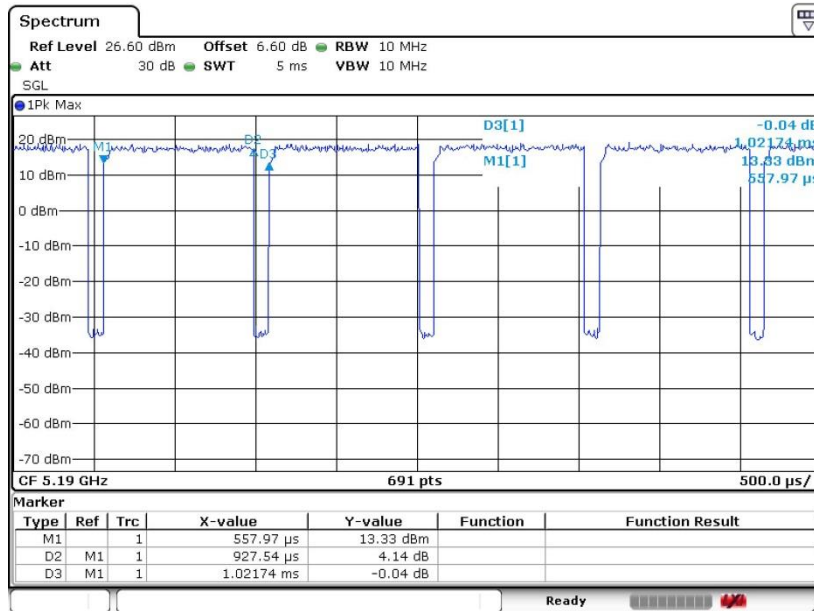

Date: 2.DEC.2019 11:12:11