

FCC Radio Test Report

FCC ID: 2AMYW-L8
FCC 47 CFR Part 15 Subpart C: 2016
RSS 247 Issue 1:2015

Product	:	Bluetooth headset
Trade Name	:	Yincine
Model No.	:	L8
Serise Model No.	:	HM-1, HM-2, HM-3, HM-4, HM-5, HM-6, HM-7, HM-8, HM-9

Issued for

Shenzhen Huangmai Technology Co.,Ltd
4/F Bldg 15, Blk C, Fangxing Technology park, Nanlian No.6 industrial Zone,
Longgang district, Shenzhen city, China

Issued by

Shenzhen ATL Testing Technology Co., Ltd.
F/4, Building 10, Dayuan Industrial Zone, Xili Town, Nanshan District, Shenzhen,
China
Tel.: +86-0755-26909822 Fax.: +86-0755-61605504
Website: www.atllab.org

Note: This report shall not be reproduced except in full, without the written approval of Shenzhen ATL Testing Technology Co., Ltd.. This document may be altered or revised by Shenzhen ATL Testing Technology Co., Ltd. personnel only, and shall be noted in the revision section of the document. The test results in the report only apply to the tested sample

TEST RESULT CERTIFICATION

Product : Bluetooth headset
Applicant : Shenzhen Huangmai Technology Co.,Ltd
Address : 4/F Bldg 15, Blk C, Fangxing Technology park, Nanlian No.6
industrial Zone, Longgang district, Shenzhen city, China
Manufacturer : Shenzhen Huangmai Technology Co.,Ltd
Address : 4/F Bldg 15, Blk C, Fangxing Technology park, Nanlian No.6
industrial Zone, Longgang district, Shenzhen city, China
Model No...... : L8
Standards : FCC Part 15 Subpart C (15.247):2016
RSS 247 Issue 1: 2015
ANSI C63.10: 2013
Test Method..... : KDB 558074 D01 DTS Meas Guidance v04

The above equipment has been tested by Shenzhen ATL Testing Technology Co., Ltd. and found compliance with the requirements set forth in the technical standards mentioned above. The results of testing in this report apply only to the product/system, which was tested. Other similar equipment will not necessarily produce the same results due to production tolerance and measurement uncertainties.

Test..... :

Date of receipt of test item 2017-06-24

Date(s) of performance of test 2017-06-27 to 2017-07-01

Test Result..... : **Pass**

Testing by	:	<i>Si feifei</i>	Date	:	2017-06-26
		(Si feifei)			_____
Check by	:	<i>Xie Lingling</i>	Date	:	2017-06-30
		(Xie Lingling)			_____
Approved by	:	<i>Xu Peng</i>	Date	:	2017-07-01
		(Xu Peng)			_____

Table of Contents	Page
1 . TEST SUMMARY	5
1.1 TEST FACILITY	6
1.2 MEASUREMENT UNCERTAINTY	6
2 . GENERAL INFORMATION	7
2.1 GENERAL DESCRIPTION OF EUT	7
2.2 DESCRIPTION OF TEST MODES	9
2.3 DESCRIPTION OF TEST SETUP	10
2.4 DESCRIPTION TEST PERIPHERAL AND EUT PERIPHERAL	11
2.5 EUT EXERCISE SOFTWARE	11
3 . CONDUCTED EMISSION TEST	12
3.1 CONDUCTED EMISSION MEASUREMENT (Frequency Range 150KHz-30MHz)	12
3.2 TEST PROCEDURE	12
3.3 TEST SETUP	13
3.4 TEST INSTRUMENTS	13
3.5 EUT OPERATING CONDITIONS	13
3.6 TEST RESULTS	13
4. RADIATED EMISSION MEASUREMENT	16
4.1 RADIATED EMISSION LIMIT (Frequency Range 9KHz-1000MHz)	16
4.2 TEST PROCEDURE	16
4.3 TEST SETUP	17
4.4 TEST INSTRUMENTS	18
4.5 EUT OPERATING CONDITIONS	18
4.6 TEST RESULTS	19
5. MAXIMUM CONDUCTED OUTPUT POWER MEASUREMENT	24
5.1 LIMITS	24
5.2 TEST PROCEDURE	24
5.3 TEST SETUP	24
5.4 TEST INSTRUMENTS	24
5.5 EUT OPERATING CONDITIONS	24
5.6 TEST RESULTS	24
6. OCCUPIED BANDWIDTH MEASUREMENT	27
6.1 LIMITS	27
6.2 TEST PROCEDURE	27

Table of Contents	Page
6.3 TEST SETUP	27
6.4 TEST INSTRUMENTS	27
6.5 EUT OPERATING CONDITIONS	27
6.6 TEST RESULTS	27
7. POWER SPECTRAL DENSITY	30
7.1 LIMITS	30
7.2 TEST PROCEDURE	30
7.3 TEST SETUP	30
7.4 TEST INSTRUMENTS	30
7.5 EUT OPERATING CONDITIONS	30
7.6 TEST RESULTS	30
8. BAND EDGE AND OUT-OF-BAND EMISSION	33
8.1 LIMITS	33
8.2 TEST PROCEDURE	33
8.3 TEST SETUP	33
8.4 TEST INSTRUMENTS	34
8.5 EUT OPERATING CONDITIONS	34
8.6 TEST RESULTS	34
9. ANTENNA REQUIREMENT	38
9.1 REQUIREMENT	38
9.2 ANTENNA CONNECTOR CONSTRUCTION	38

1. TEST SUMMARY

Test procedures according to the technical standards:

FCC Part 15 Subpart C (15.247)/RSS 247 Issue 1				
Standard Section		Test Item	Judgment	Remark
FCC	IC			
15.203	/	Antenna Requirement	PASS	
15.207	RSS-GEN 7.2.4	Conducted Emission	N/A	N/A
15.205/ 15.209	RSS-GEN 7.2.2	Restricted Bands	PASS	
15.247(a)(2)	RSS 247 5.2 (1)	6dB Bandwidth	PASS	
15.247(b)	RSS 247 5.4 (4)	Peak Output Power	PASS	
15.247(e)	RSS 247 5.2 (2)	Power Spectral Density	PASS	
15.247(d)	RSS 247 5.5	Band Edge/Out-of-band Emission	PASS	

NOTE:

(1) "N/A" denotes test is not applicable in this Test Report

(2) The test results of this report relate only to the tested sample(s) identified in this report.

1.1 TEST FACILITY

Shenzhen ATL Testing Technology Co., Ltd.

Add. : F/4, Building 10, Dayuan Industrial Zone, Xili Town, Nanshan District, Shenzhen, China

1.2 MEASUREMENT UNCERTAINTY

The reported uncertainty of measurement $y \pm U$, where expanded uncertainty U is based on a standard uncertainty multiplied by a coverage factor of $k=2$, providing a level of confidence of approximately **95** %.

A. Conducted Emission :

The measurement uncertainty is evaluated as ± 3.2 dB.

B. Radiated Measurement :

The measurement uncertainty is evaluated as ± 3.7 dB.

2. GENERAL INFORMATION

2.1 GENERAL DESCRIPTION OF EUT

Equipment	Bluetooth headset
Model Name	L8
Additional Model Number(s)	HM-1, HM-2, HM-3, HM-4, HM-5, HM-6, HM-7, HM-8, HM-9
Model Difference	All these models are identical in the same PCB, layout and electrical circuit, the only difference is model name for commercial.
Frequency Range	Bluetooth 4.1(BLE): 2402~2480 MHz
Number of Channel:	40 Channels
Modulation Type	GFSK
RF Output Power	-3.453dBm
Antenna Type	PCB Antenna (Gain: 2dBi)
Power Source	DC Powered by host system or Battery .
Power Rating	DC 5V from USB interference. DC 3.7V 150mAh from Battery.
Remark	More details EUT technical specifications, please refer to the User's Manual.

Note:

(1) This Test Report is FCC Part 15 Subpart C, 15.247 for BLE. And the Test procedure follows the FCC KDB 558074 D01 DTS Meas Guidance v04.

(2) Transmitting mode with antennas

Mode	TX Antenna (s)
BLE	1

(3) Channel List.

2.4 GHz Band				
Frequency Band	Channel No.	Frequency	Channel No.	Frequency
2402~2480MHz	0	2402 MHz	20	2442 MHz
	1	2404 MHz	21	2444 MHz
	2	2406 MHz	22	2446 MHz
	3	2408 MHz	23	2448 MHz
	4	2410 MHz	24	2450 MHz
	5	2412 MHz	25	2452 MHz
	6	2414 MHz	26	2454 MHz
	7	2416MHz	27	2456 MHz
	8	2418 MHz	28	2458 MHz
	9	2420 MHz	29	2460 MHz
	10	2422 MHz	30	2462 MHz
	11	2424 MHz	31	2464 MHz
	12	2426 MHz	32	2466 MHz
	13	2428 MHz	33	2468 MHz
	14	2430 MHz	34	2470 MHz
	15	2432 MHz	35	2472 MHz
	16	2434MHz	36	2474 MHz
	17	2436 MHz	37	2476 MHz
	18	2438 MHz	38	2478 MHz
	19	2440 MHz	39	2480 MHz

2.2 DESCRIPTION OF TEST MODES

To investigate the maximum EMI emission characteristics generated from EUT, the test system was pre-scanning tested based on the consideration of following EUT operation mode or test configuration mode which possibly have effect on EMI emission level. Each of these EUT operation mode(s) or test configuration mode(s) mentioned above was evaluated respectively.

Pretest Mode	Description
Mode 1	BLE TX Mode

For Conducted Test	
Final Test Mode	Description
Mode 1	BLE TX Mode

For Radiated Test	
Final Test Mode	Description
Mode 1	BLE TX Mode

Note:

- (1) Software used to control the EUT for staying in continuous transmitting mode was programmed. After verification, all tests were carried out with the worst case test modes as shown below.
- (2) BLE(GFSK) Mode:
Channel (2402/2442/2480 MHz) with 1Mbps data rate were chosen for full testing.
- (3) By preliminary testing and verifying three axis (X, Y and Z) position of EUT transmitted status, it was found that "X axis" position was the worst, then the final test was executed the worst condition and test data were recorded in this report.

2.3 DESCRIPTION OF TEST SETUP

Conducted Emission

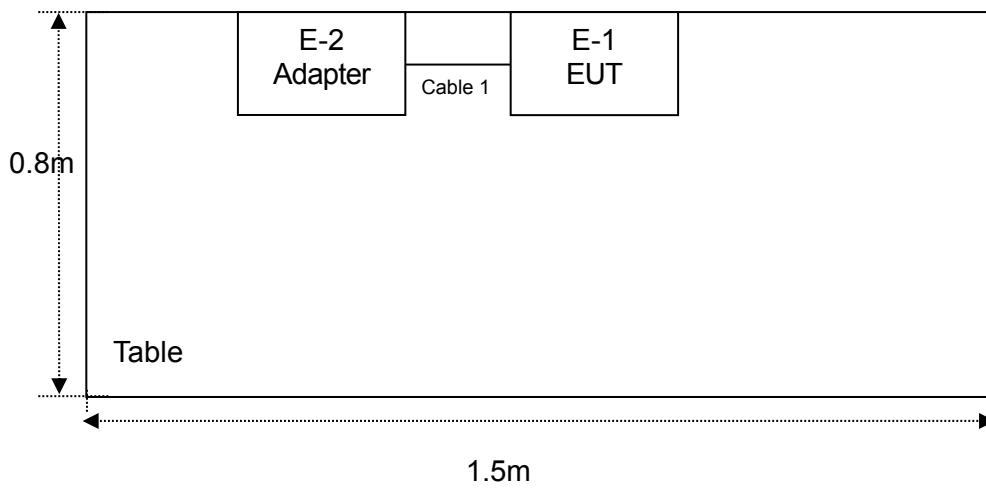

Radiated Emission

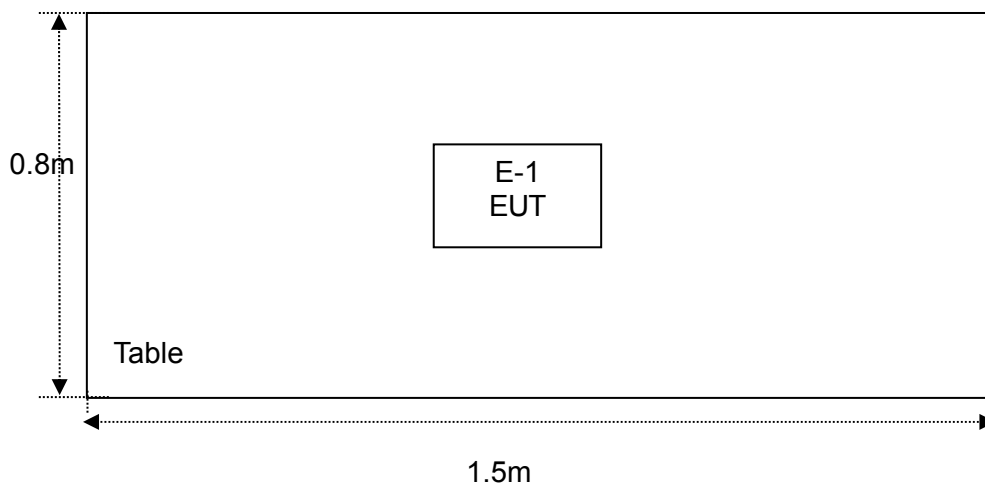

2.4 DESCRIPTION TEST PERIPHERAL AND EUT PERIPHERAL

The EUT has been tested as an independent unit together with other necessary accessories or support units. The following support units or accessories were used to form a representative test configuration during the tests.

Item	Equipment	Mfr/Brand	Model/Type No.	VOC/DOC	Note
E-1	Bluetooth headset	N/A	L8	/	EUT
E-2	Adapter	N/A	KA1517-050200CNU	VOC	EUT

Item	Shielded Type	Ferrite Core	Length	Note
1	NO	NO	0.4m	

Note:

- (1) The support equipment was authorized by Verification of Confirmation.
- (2) For detachable type I/O cable should be specified the length in cm in 『Length』 column.
- (3) “YES” means “shielded” “with core”; “NO” means “unshielded” “without core”.

2.5 EUT EXERCISE SOFTWARE

Power Parameters for Testing			
Test Software Version	BlueTest 3		
Mode	Frequency/ Parameters		
BLE(GFSK)	2402 MHz	2442 MHz	2480 MHz
	DEF	DEF	DEF

3. CONDUCTED EMISSION TEST

3.1 CONDUCTED EMISSION MEASUREMENT (Frequency Range 150KHz-30MHz)

FREQUENCY (MHz)	Quasi-peak	Average
	dBuV	dBuV
0.15 -0.5	66 - 56 *	56 - 46 *
0.50 -5.0	56.00	46.00
5.0 -30.0	60.00	50.00

Note:

- (1) The tighter limit applies at the band edges.
- (2) The limit of " * " marked band means the limitation decreases linearly with the logarithm of the frequency in the range.

The following table is the setting of the receiver

Receiver Parameters	Setting
Attenuation	10 dB
Start Frequency	0.15 MHz
Stop Frequency	30 MHz
IF Bandwidth	9 kHz

3.2 TEST PROCEDURE

- a. The EUT was placed 0.8 meters from the horizontal ground plane with EUT being connected to the power mains through a line impedance stabilization network (LISN). All other support equipments powered from additional LISN(s). The LISN provide 50 Ohm/ 50uH of coupling impedance for the measuring instrument.
- b. Interconnecting cables that hang closer than 40 cm to the ground plane shall be folded back and forth in the center forming a bundle 30 to 40 cm long.
- c. I/O cables that are not connected to a peripheral shall be bundled in the center. The end of the cable may be terminated, if required, using the correct terminating impedance. The overall length shall not exceed 1 m.
- d. LISN at least 80 cm from nearest part of EUT chassis.
- e. For the actual test configuration, please refer to the related Item –EUT Test Photos.

3.3 TEST SETUP

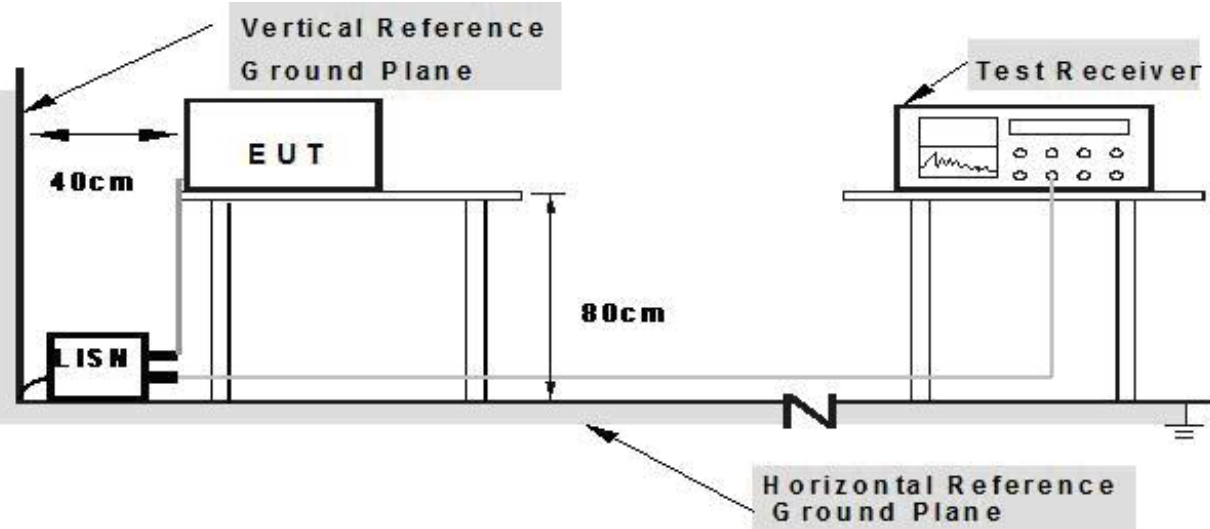

- Note: 1. Support units were connected to second LISN.**
2. Both of LISNs (AMN) are 80 cm from EUT and at least 80 from other units and other metal planes

3.4 TEST INSTRUMENTS

Equipment	Manufacturer	Type No.	Serial No.	Last calibration	Calibrated until	Calibration period
LISN	R&S	NSLK81	8126466	Jul. 04, 2016	Jul. 03. 2017	1 year
LISN	R&S	NSLK81	8126487	Jul. 04, 2016	Jul. 03. 2017	1 year
50Ω Switch	ANRITSU CORP	MP59B	6200983704	Jul. 04, 2016	Jul. 03. 2017	1 year
Test Cable	N/A	C01	N/A	Jul. 04, 2016	Jul. 03. 2017	1 year
Test Cable	N/A	C02	N/A	Jul. 04, 2016	Jul. 03. 2017	1 year
Test Cable	N/A	C03	N/A	Jul. 04, 2016	Jul. 03. 2017	1 year
EMI Test Receiver	R&S	ESCI	1166.595	Jul. 04, 2016	Jul. 03. 2017	1 year
Passive Voltage Probe	ESH2-Z3	R&S	100196	Jul. 04, 2016	Jul. 03. 2017	1 year

3.5 EUT OPERATING CONDITIONS

The EUT tested system was configured as the statements of 2.3 Unless otherwise a special operating condition is specified in the follows during the testing.

3.6 TEST RESULTS

EUT :	Bluetooth headset	Model Name. :	L8
Temperature :	26 °C	Relative Humidity :	56%
Pressure :	1010hPa	Test Date :	2017-06-27
Test Mode :	Mode 1	Phase :	Line
Test Voltage :	AC 120V/ 60Hz		

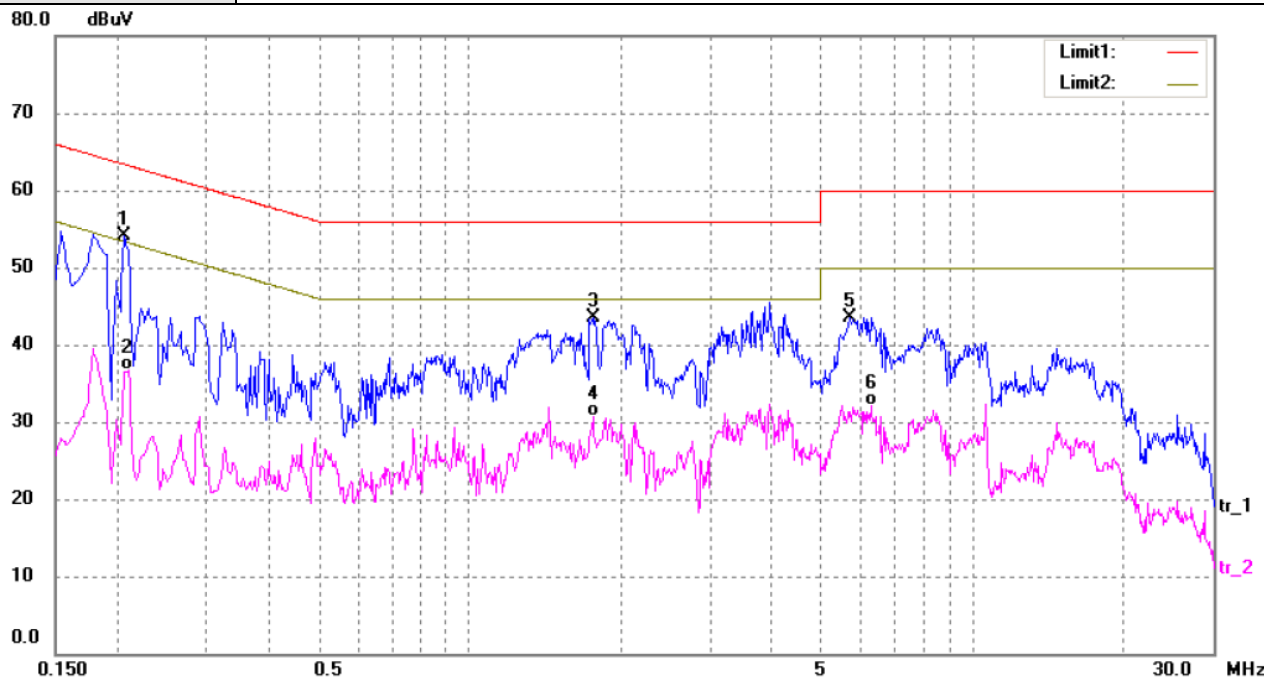

No.	Frequency (MHz)	Reading (dBuV)	Correct (dB/m)	Result (dBuV)	Limit (dBuV)	Margin (dB)	Detector
1*	0.2060	44.55	9.50	54.05	63.37	-9.32	peak
2	0.2100	27.23	9.50	36.73	53.21	-16.48	AVG
3	1.7540	33.70	9.79	43.49	56.00	-12.51	peak
4	1.7540	20.88	9.79	30.67	46.00	-15.33	AVG
5	5.7100	33.22	10.26	43.48	60.00	-16.52	peak
6	6.2580	21.77	10.27	32.04	50.00	-17.96	AVG

Remark:

1. All readings are Quasi-Peak and Average values.
2. Factor = Insertion Loss + Cable Loss.

EUT :	Bluetooth headset	Model Name. :	L8
Temperature :	26 °C	Relative Humidity :	56%
Pressure :	1010hPa	Test Date :	2017-06-27
Test Mode :	Mode 1	Phase :	Neutral
Test Voltage :	AC 120V/ 60Hz		

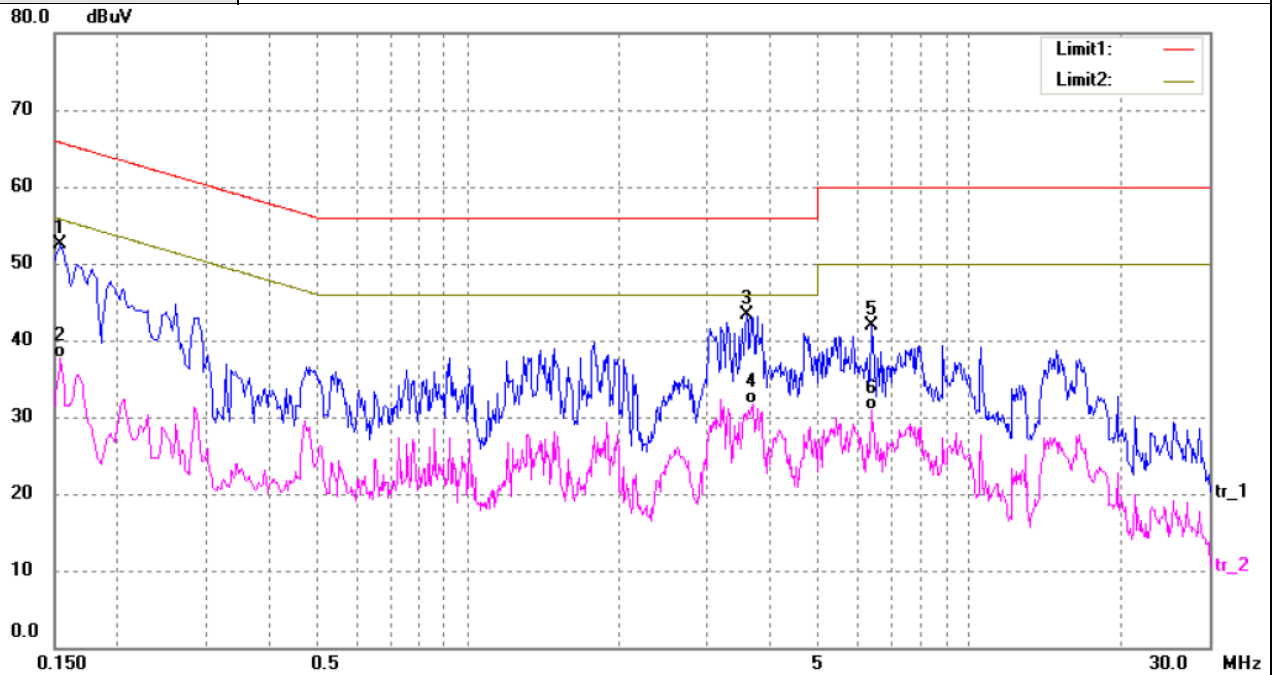

No.	Frequency (MHz)	Reading (dBuV)	Correct (dB/m)	Result (dBuV)	Limit (dBuV)	Margin (dB)	Detector
1	0.1540	43.07	9.50	52.57	65.78	-13.21	peak
2	0.1540	28.27	9.50	37.77	55.78	-18.01	AVG
3*	3.5860	33.26	10.04	43.30	56.00	-12.70	peak
4	3.6820	21.64	10.06	31.70	46.00	-14.30	AVG
5	6.3580	31.68	10.27	41.95	60.00	-18.05	peak
6	6.3580	20.65	10.27	30.92	50.00	-19.08	AVG

Remark:

1. All readings are Quasi-Peak and Average values.
2. Factor = Insertion Loss + Cable Loss.

4. RADIATED EMISSION MEASUREMENT

4.1 RADIATED EMISSION LIMIT (Frequency Range 9KHz-1000MHz)

20 dBc in any 100 kHz bandwidth outside the operating frequency band. In case the emission fall within the restricted band specified on 15.205(a) and RSS-210 Section 2.2&A8.5, then the 15.209(a) and RSS-General limit in the table below has to be followed.

FREQUENCY (MHz)	Field Strength (uV/m at meter)	Measurement Distance (meters)
0.009 -0.490	2400/F(KHz)	300
0.490 -1.705	24000/F(KHz)	30
1.705 -30.0	30	30
30 -88	100	3
88 -216	150	3
216~960	200	3
Above 960	500	3

RADIATED EMISSION LIMITS (Above 1000MHz)

FREQUENCY (MHz)	Distance of 3m (dBuV/m)	
	Peak	Average
Above 1000	74	54

Note:

- (1) The limit for radiated test was performed according to FCC PART 15C.
- (2) The tighter limit applies at the band edges.
- (2) Emission Level(dBuV/m)=20log Emission Level(uV/m)

The following table is the setting of the receiver

Receiver Parameter	Setting
Attenuation	Auto
Start Frequency~ Stop Frequency	9kHz~150kHz/ RB 200Hz for QP
Start Frequency~ Stop Frequency	150kHz~30MHz/ RB 9kHz for QP
Start Frequency~ Stop Frequency	30MHz~1000MHz/ RB120kHz for QP

The following table is the setting of the spectrum

Spectrum Parameter	Setting
Attenuation	Auto
Start Frequency	1000 MHz
Stop Frequency	10 th carrier harmonic
RB/ VB (emission in restricted band)	1MHz/ 3 MHz for Peak, 1MHz/ 10Hz for Average

4.2 TEST PROCEDURE

- a. The measuring distance of at 3 m shall be used for measurements at frequency up to 1GHz. For frequencies above 1GHz, any suitable measuring distance may be used.
- b. The EUT was placed on the top of a rotating table 0.8 meters above the ground at a 3 meter open area test site. The table was rotated 360 degrees to determine the position of the highest radiation.

- c. The height of the equipment or of the substitution antenna shall be 0.8 m; the height of the test antenna shall vary between 1 m to 4 m. Both horizontal and vertical polarizations of the antenna are set to make the measurement.
- d. The initial step in collecting conducted emission data is a spectrum analyzer peak detector mode pre-scanning the measurement frequency range. Significant peaks are then marked and then Quasi Peak detector mode re-measured, above 1G Average detector mode will be instead.
- e. If the Peak Mode measured value compliance with and lower than Quasi Peak Mode Limit, the EUT shall be deemed to meet QP Limits and then no additional QP Mode measurement performed.
- f. For the actual test configuration, please refer to the related Item –EUT Test Photos.

Note:

Both horizontal and vertical antenna polarities were tested.

And performed pretest to three orthogonal axis. The worst case emissions were reported.

4.3 TEST SETUP

(A) Radiated Emission Test Set-Up Frequency Below 30MHz

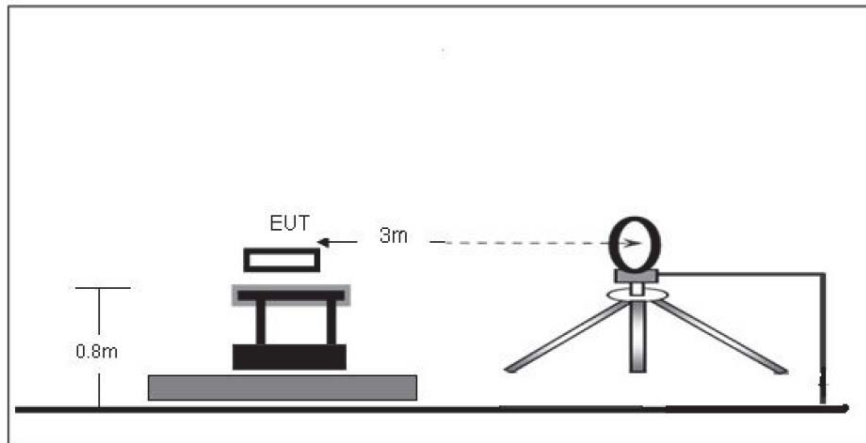

(B) Radiated Emission Test Set-Up Frequency Below 1 GHz

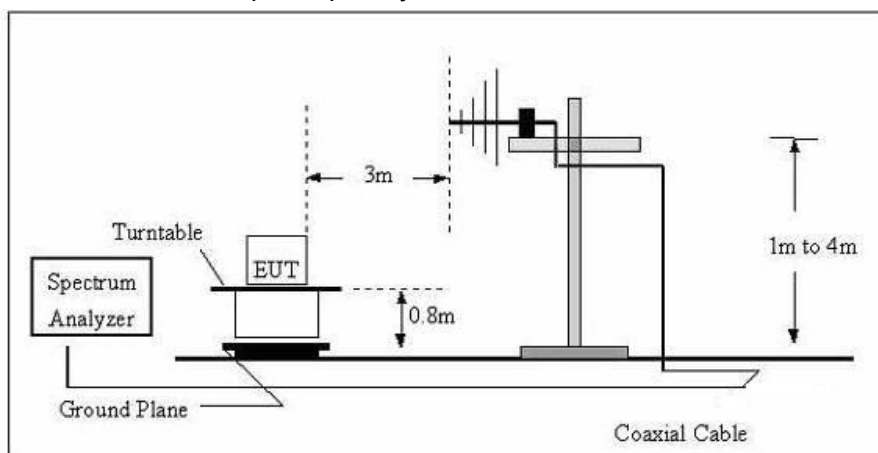

(C) Radiated Emission Test Set-Up Frequency Above 1GHz

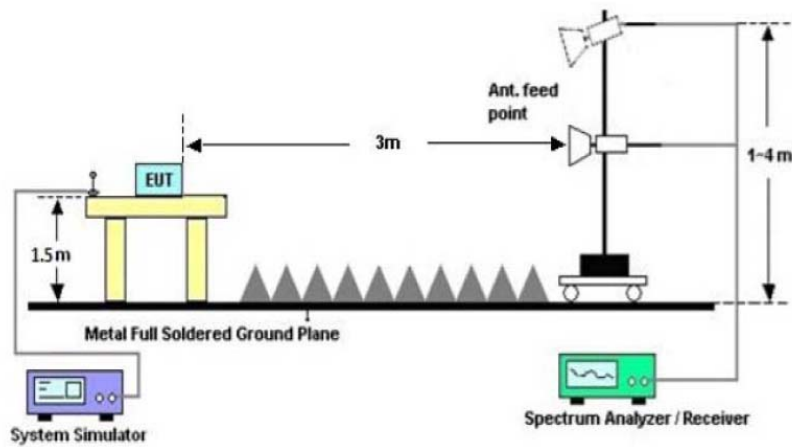

4.4 TEST INSTRUMENTS

Equipment	Manufacturer	Type No.	Serial No.	Last calibration	Calibrated until	Calibration period
Broadband Antenna	R&S	VULB 9168	VULB 9168-456	Jul. 04, 2016	Jul. 03. 2017	1 year
Test Cable	N/A	R-01	N/A	Jul. 04, 2016	Jul. 03. 2017	1 year
Test Cable	N/A	R-02	N/A	Jul. 04, 2016	Jul. 03. 2017	1 year
EMI Test Receiver	R&S	ESCI	101324	Jul. 04, 2016	Jul. 03. 2017	1 year
Antenna Mast	EM	SC100_1	N/A	N/A	N/A	N/A
Turn Table	EM	SC100	060531	N/A	N/A	N/A
50Ω Switch	Anritsu Corp	MP59B	6200983705	Jul. 04, 2016	Jul. 03. 2017	1 year
Spectrum Analyzer	R&S	FSP40	100154	Jul. 04, 2016	Jul. 03. 2017	1 year
Horn Antenna	R&S	HF906	10029	Jul. 04, 2016	Jul. 03. 2017	1 year
Broadband Antenna	Schwarz beck	VULB9163	9163-333	Jul. 04, 2016	Jul. 03. 2017	1 year
Loop Antenna	Schwarz beck	FMZB 1516	9773	Jul. 04, 2016	Jul. 03. 2017	1 year
Amplifier	EM	EM-30180	060538	Jul. 04, 2016	Jul. 03. 2017	1 year

4.5 EUT OPERATING CONDITIONS

The EUT tested system was configured as the statements of 2.3 Unless otherwise a special operating condition is specified in the follows during the testing.

4.6 TEST RESULTS

3.6.1 TEST RESULTS (9KHz~ 30MHz)

Note: The amplitude of spurious emissions which are attenuated by more than 20dB below the permissible value has no need to be reported.

3.6.2 TEST RESULTS (Bellow 1GHz)

EUT :	Bluetooth headset	Model Name. :	L8
Temperature :	26 °C	Relative Humidity :	56%
Pressure :	1010 hPa	Test Date :	2017-06-26
Test Mode :	BLE TX Mode (2402MHz)	Polarization :	Horizontal
Test Power :	DC 3.7V		
Remark :	Only show the worse case.		

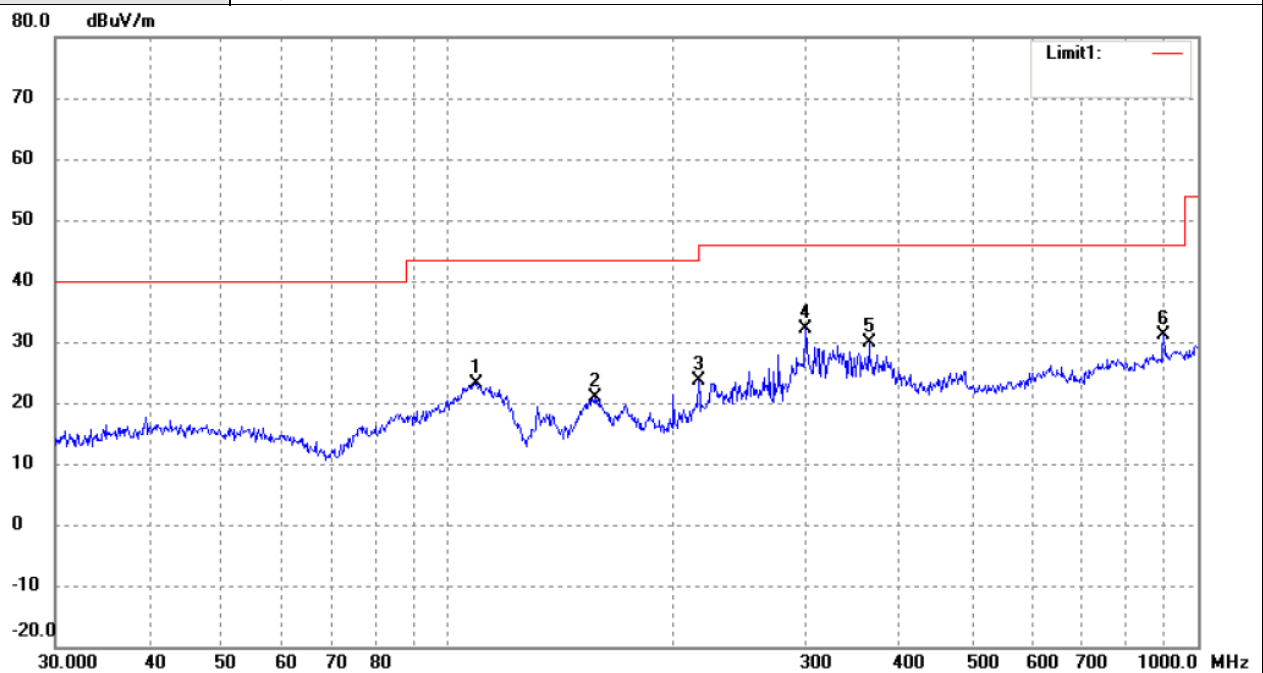

No.	Frequency (MHz)	Reading (dBuV/m)	Correct (dB/m)	Result (dBuV/m)	Limit (dBuV/m)	Margin (dB)	Degree (°)	Height (cm)	Remark
1	109.0286	34.33	-11.14	23.19	43.50	-20.31	100	100	peak
2	157.0074	33.29	-12.31	20.98	43.50	-22.52	100	100	peak
3	216.0240	32.52	-8.81	23.71	46.00	-22.29	100	100	peak
4	300.3673	37.84	-5.63	32.21	46.00	-13.79	100	100	peak
5	364.2595	32.76	-3.00	29.76	46.00	-16.24	100	100	peak
6	900.1474	27.90	3.15	31.05	46.00	-14.95	100	100	peak

Remark:
Factor = Antenna Factor + Cable Loss.

EUT :	Bluetooth headset	Model Name. :	L8
Temperature :	26 °C	Relative Humidity :	56%
Pressure :	1010 hPa	Test Date :	2017-06-26
Test Mode :	BLE TX Mode (2402MHz)	Polarization :	Vertical
Test Power :	DC 3.7V		
Remark :	Only show the worse case.		

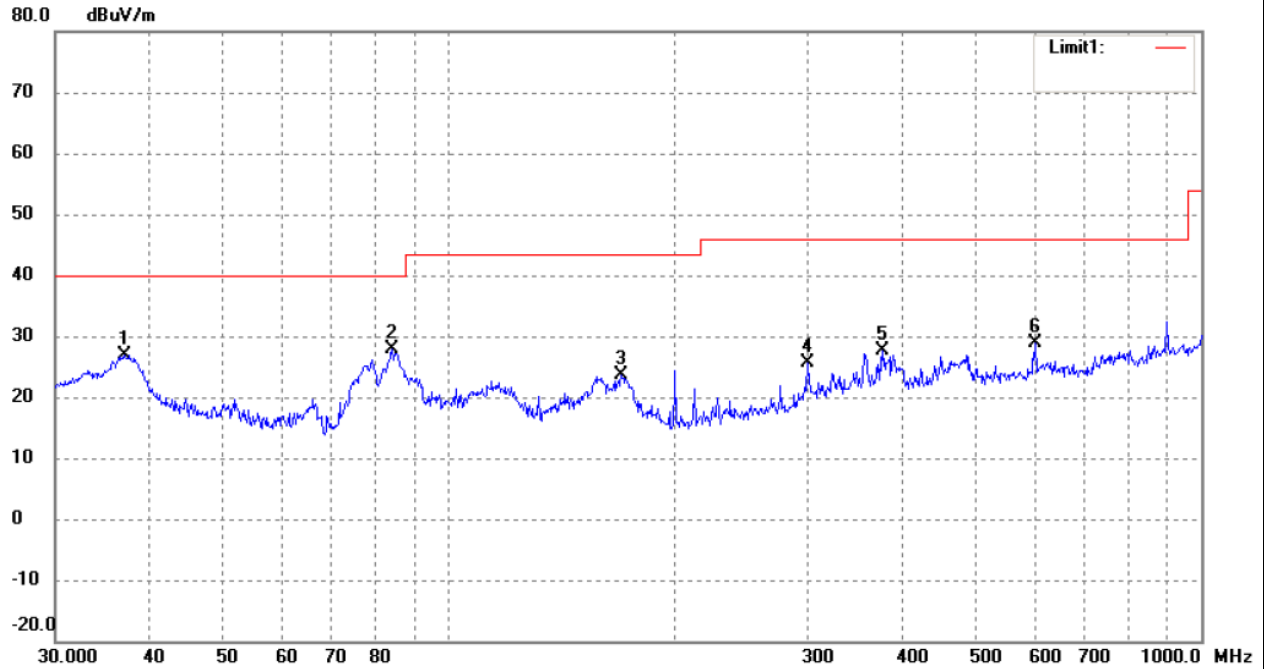

No.	Frequency (MHz)	Reading (dBuV/m)	Correct (dB/m)	Result (dBuV/m)	Limit (dBuV/m)	Margin (dB)	Degree (°)	Height (cm)	Remark
1	37.0249	35.45	-8.48	26.97	40.00	-13.03	100	100	peak
2	84.1100	40.25	-12.38	27.87	40.00	-12.13	100	100	peak
3	169.5990	35.42	-11.83	23.59	43.50	-19.91	100	100	peak
4	299.3158	31.20	-5.66	25.54	46.00	-20.46	100	100	peak
5	377.2591	29.92	-2.26	27.66	46.00	-18.34	100	100	peak
6	601.4265	28.98	-0.05	28.93	46.00	-17.07	100	100	peak

Remark:
Factor = Antenna Factor + Cable Loss.

3.6.3 TEST RESULTS (Above 1GHz)

EUT :	Bluetooth headset			Model Name. :	L8		
Temperature :	26 °C			Relative Humidity :	56%		
Test Power :	DC 3.7V			Pressure :	1010 hPa		
Test Mode :	BLE TX 2402MHz			Test Date :	2017-06-26		
Freq.	Deceiver Reading	Detector	Polar	Corrected Factor	Emission Level	Limit	Margin
MHz	dBuV	Peak/Avg	H/V	dB	dBuV /m	dBuV /m	dB
4804	66.34	Peak	H	-3.59	62.75	74	-11.25
4804	52.73	Avg	H	-3.59	49.14	54	-4.86
7206	58.19	Peak	H	-0.52	57.67	74	-16.33
7206	45.20	Avg	H	-0.52	44.68	54	-9.32
---	---	Peak	H			74	
---	---	Avg	H			54	
4804	65.21	Peak	V	-3.59	61.62	74	-12.38
4804	53.64	Avg	V	-3.59	50.05	54	-3.95
7206	58.66	Peak	V	-0.52	58.14	74	-15.86
7206	47.20	Avg	V	-0.52	46.68	54	-7.32
---	---	Peak	V			74	
---	---	Avg	V			54	

Remark:

Emission Level= Read Level+ Correct Factor

Margin= Emission Level-Limit

The testing has been conformed to 10th harmonics(1G~25G)

Other harmonics emission are lower then 20dB below the allowable Limit

EUT :	Bluetooth headset			Model Name. :	L8		
Temperature :	26 °C			Relative Humidity :	56%		
Test Power :	DC 3.7V			Pressure :	1010 hPa		
Test Mode :	BLE TX 2442MHz			Test Date :	2017-06-26		
Freq.	Deceiver Reading	Detector	Polar	Corrected Factor	Emission Level	Limit	Margin
MHz	dBuV	Peak/Avg	H/V	dB	dBuV /m	dBuV /m	dB
4884	65.45	Peak	H	-3.49	61.96	74	-12.04
4884	53.12	Avg	H	-3.49	49.63	54	-4.37
7326	59.39	Peak	H	-0.47	58.92	74	-15.08
7326	46.15	Avg	H	-0.47	45.68	54	-8.32
---	---	Peak	H			74	
---	---	Avg	H			54	
4884	65.46	Peak	V	-3.49	61.97	74	-12.03
4884	52.77	Avg	V	-3.49	49.28	54	-4.72
7326	58.51	Peak	V	-0.47	58.04	74	-15.96
7326	45.64	Avg	V	-0.47	45.17	54	-8.83
---	---	Peak	V			74	
---	---	Avg	V			54	

Remark:
 Emission Level= Read Level+ Correct Factor
 Margin= Emission Level-Limit
 The testing has been conformed to 10th harmonics(1G~25G)
 Other harmonics emission are lower then 20dB below the allowable Limit

EUT :	Bluetooth headset			Model Name. :	L8		
Temperature :	26 °C			Relative Humidity :	56%		
Test Power :	DC 3.7V			Pressure :	1010 hPa		
Test Mode :	BLE TX 2480MHz			Test Date :	2017-06-26		
Freq.	Deceiver Reading	Detector	Polar	Corrected Factor	Emission Level	Limit	Margin
MHz	dBuV	Peak/Avg	H/V	dB	dBuV /m	dBuV /m	dB
4960	65.96	Peak	H	-3.41	62.55	74	-11.45
4960	53.9	Avg	H	-3.41	50.49	54	-3.51
7440	57.94	Peak	H	-0.42	57.52	74	-16.48
7440	46.70	Avg	H	-0.42	46.28	54	-7.72
---	---	Peak	H			74	
---	---	Avg	H			54	
4960	64.85	Peak	V	-3.41	61.44	74	-12.56
4960	53.46	Avg	V	-3.41	50.05	54	-3.95
7440	58.43	Peak	V	-0.42	58.01	74	-15.99
7440	47.05	Avg	V	-0.42	46.63	54	-7.37
---		Peak	V			74	
---		Avg	V			54	

Remark:
 Emission Level= Read Level+ Correct Factor
 Margin= Emission Level-Limit
 The testing has been conformed to 10th harmonics(1G~25G)
 Other harmonics emission are lower then 20dB below the allowable Limit

5. MAXIMUM CONDUCTED OUTPUT POWER MEASUREMENT

5.1 LIMITS

FCC Part 15.247, subpart C/ RSS 247 Section 5.4(4)	
Frequency Range (MHz)	2400~2483.5
Limits	30

5.2 TEST PROCEDURE

The measurement is according to section 9.1.2 of FCC KDB 558074 D01 DTS Meas Guidance v04.

The EUT was directly connected to the Spectrum Analyzer and antenna output port as show in the block diagram as bellow.

5.3 TEST SETUP

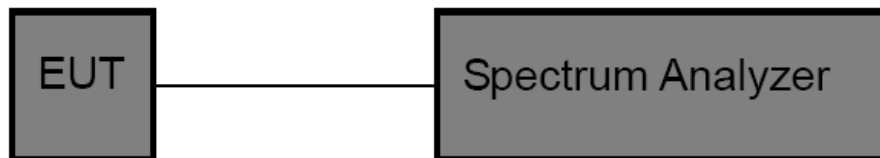

5.4 TEST INSTRUMENTS

Equipment	Manufacturer	Type No.	Serial No.	Last calibration	Calibrated until	Calibration period
Spectrum Analyzer	R&S	FSP40	100154	Jul. 04, 2016	Jul. 03. 2017	1 year
Spectrum Analyzer	Agilent	E4407B	MY41440432	Jul. 04, 2016	Jul. 03. 2017	1 year

5.5 EUT OPERATING CONDITIONS

The EUT was set to continuously transmitting in the maximum power during the test.

5.6 TEST RESULTS

BLE(GFSK) Mode		
Frequency (MHz)	Peak Output Power (dBm)	Limit (dBm)
2402	-3.453	<30
2442	-4.425	
2480	-5.124	

2402 MHz

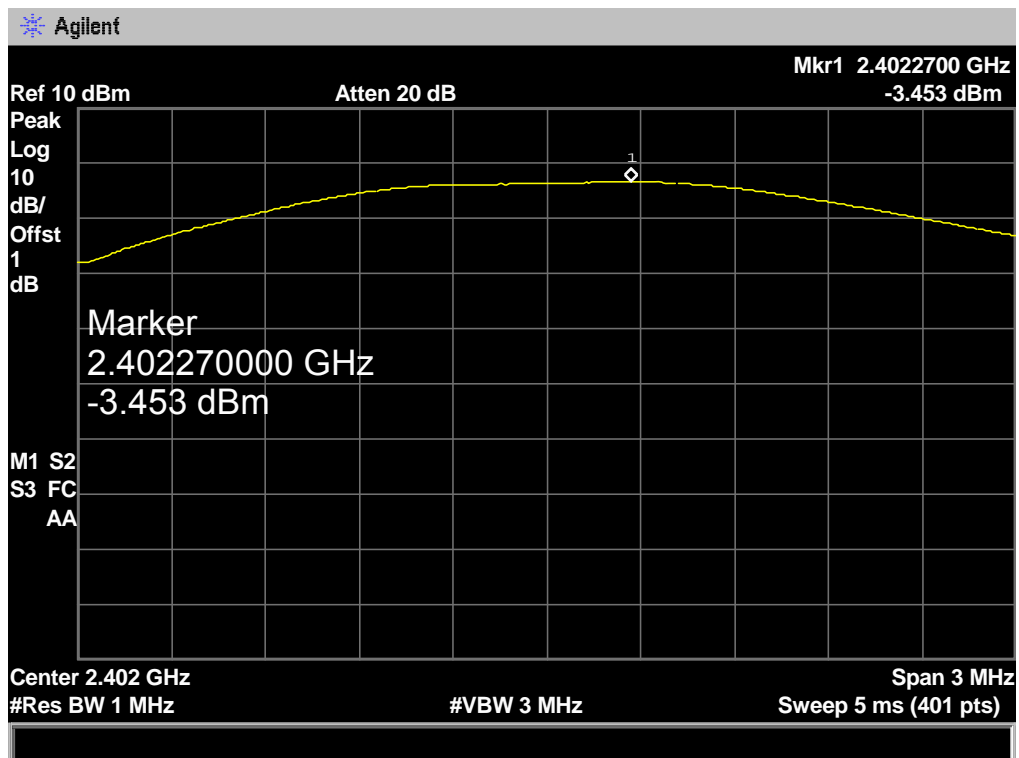

2442 MHz

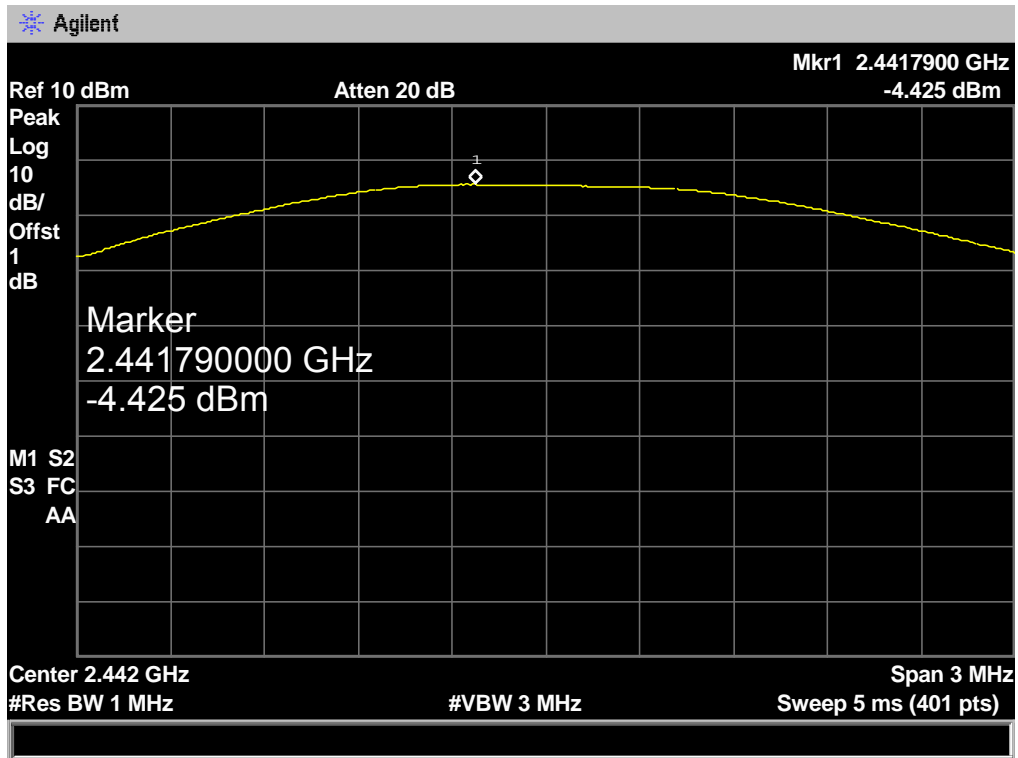

2480 MHz

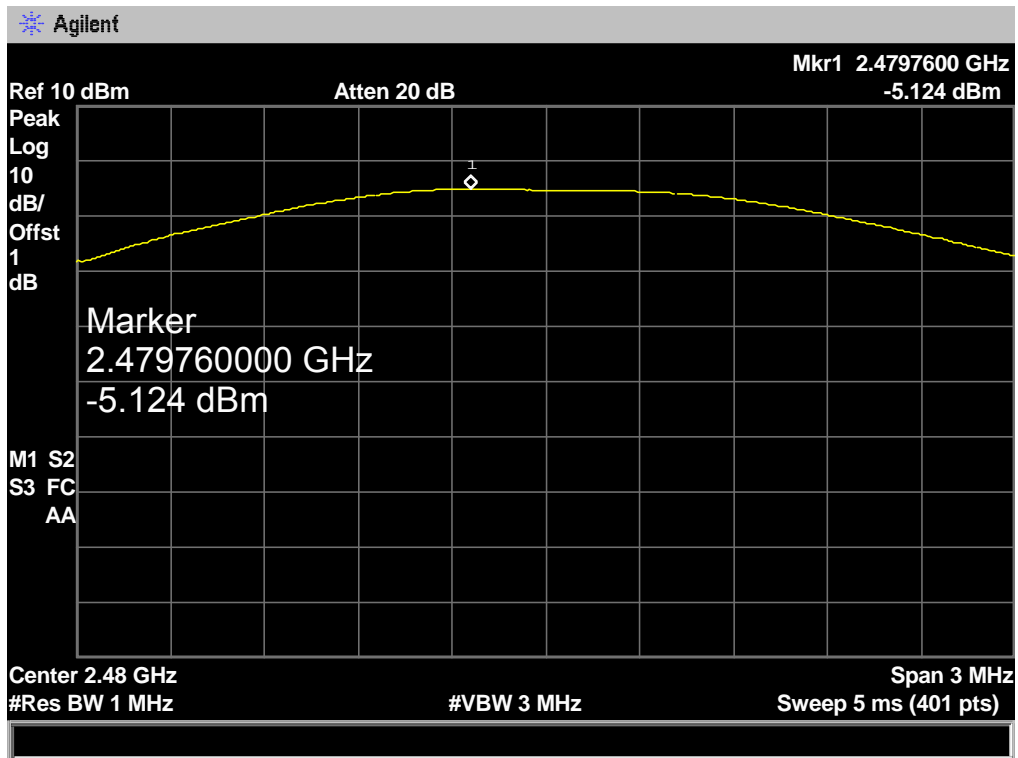

6. OCCUPIED BANDWIDTH MEASUREMENT

6.1 LIMITS

FCC Part 15.247, subpart C/ RSS 247 Section 5.2(1)	
Frequency Range (MHz)	2400~2483.5
Limits	6 dB Bandwidth>500 KHz

6.2 TEST PROCEDURE

The EUT was directly connected to the Spectrum Analyzer and antenna output port as show in the block diagram as bellow.

Spectrum Parameters	Setting
Attenuation	Auto
Span	>6 dB Bandwidth
RBW	100 kHz
VBW	≥3RBW
Detector	Peak
Trace	Max Hold
Sweep Time	Auto

6.3 TEST SETUP

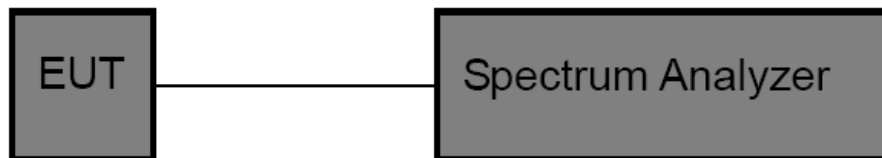

6.4 TEST INSTRUMENTS

Equipment	Manufacturer	Type No.	Serial No.	Last calibration	Calibrated until	Calibration period
Spectrum Analyzer	R&S	FSP40	100154	Jul. 04, 2016	Jul. 03. 2017	1 year
Spectrum Analyzer	Agilent	E4407B	MY41440432	Jul. 04, 2016	Jul. 03. 2017	1 year

6.5 EUT OPERATING CONDITIONS

The EUT was set to continuously transmitting in the maximum power during the test.

6.6 TEST RESULTS

BLE (GFSK) Mode			
Frequency (MHz)	6dB Bandwidth (KHz)	99% OBW (MHz)	Limit
2402	718.439	1.1112	≥500 kHz
2442	722.597	1.1027	
2480	721.732	1.1055	

2402 MHz

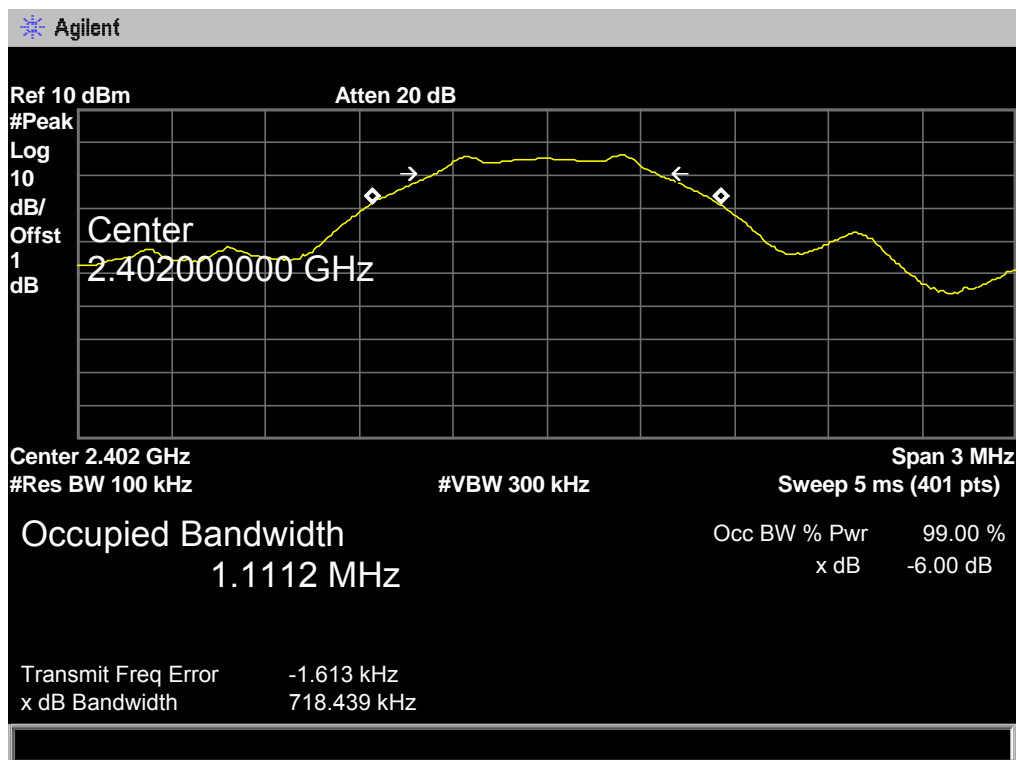

2442 MHz

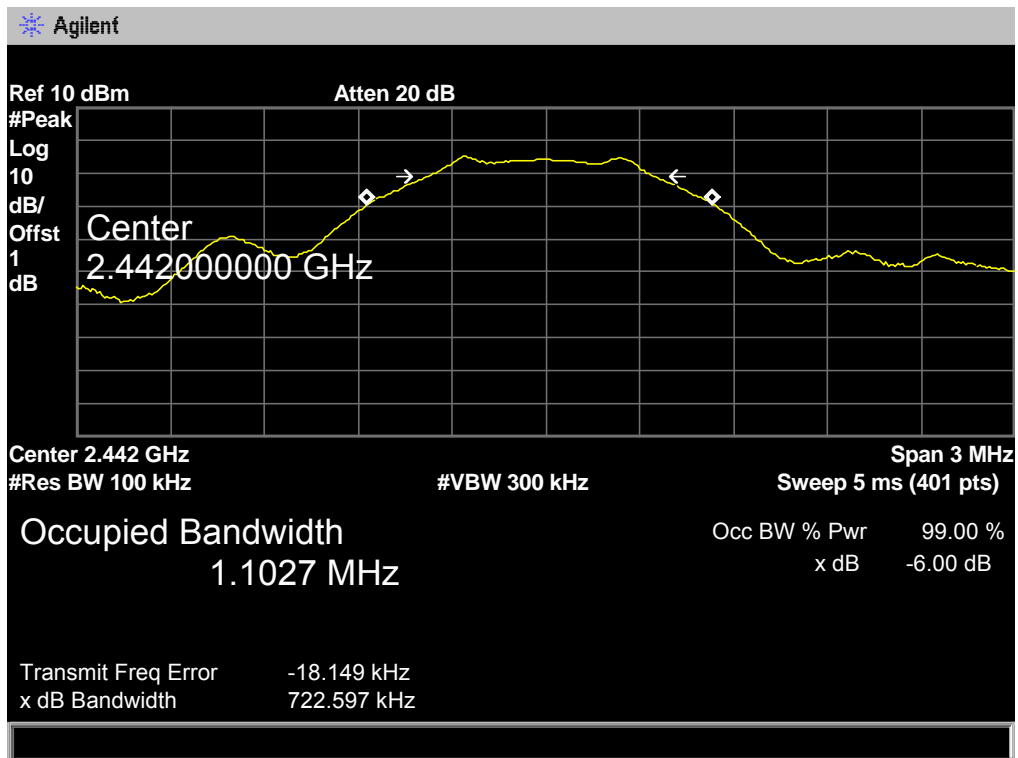

2480 MHz

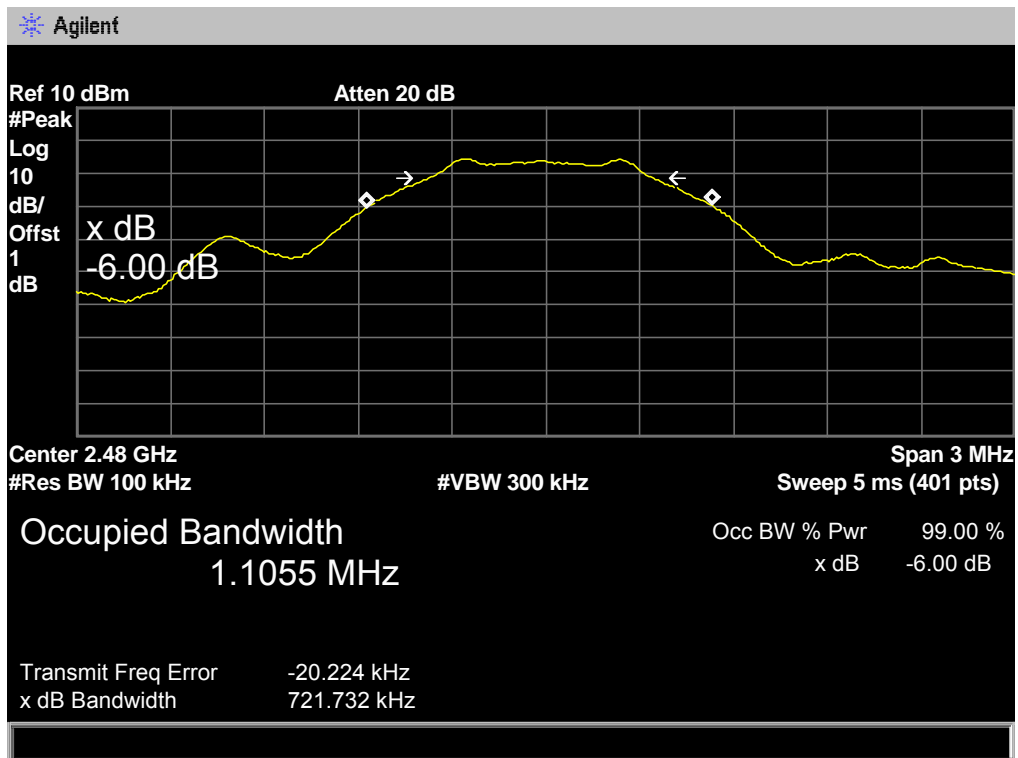

7. POWER SPECTRAL DENSITY

7.1 LIMITS

FCC Part 15.247, Subpart C/ RSS 247 Section 5.2(2)	
Frequency Range (MHz)	2400~2483.5
99% Occupied Bandwidth	8 dBm in any 3 kHz

7.2 TEST PROCEDURE

The EUT was directly connected to the Spectrum Analyzer and antenna output port as show in the block diagram as bellow.

Spectrum Parameters	Setting
Attenuation	Auto
Span	Set the span to 1.5 times the DTS channel bandwidth
RBW	3 kHz
VBW	$\geq 3\text{RBW}$
Detector	Reak
Trace	Max Hold
Sweep Time	Auto

7.3 TEST SETUP

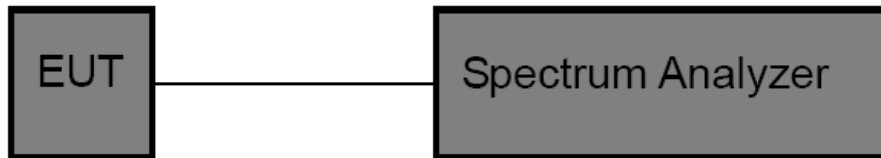

7.4 TEST INSTRUMENTS

Equipment	Manufacturer	Type No.	Serial No.	Last calibration	Calibrated until	Calibration period
Spectrum Analyzer	R&S	FSP40	100154	Jul. 04, 2015	Jul. 03. 2017	1 year
Spectrum Analyzer	Agilent	E4407B	MY41440432	Jul. 04, 2016	Jul. 03. 2017	1 year

7.5 EUT OPERATING CONDITIONS

The EUT was set to continuously transmitting in the maximum power during the test.

7.6 TEST RESULTS

BLE (GFSK) Mode			
Frequency (MHz)	Power Density (3 kHz/dBm)	Limit (dBm/3KHz)	Result
2402	-15.61	8	Pass
2442	-15.95		
2480	-16.60		

2402 MHz

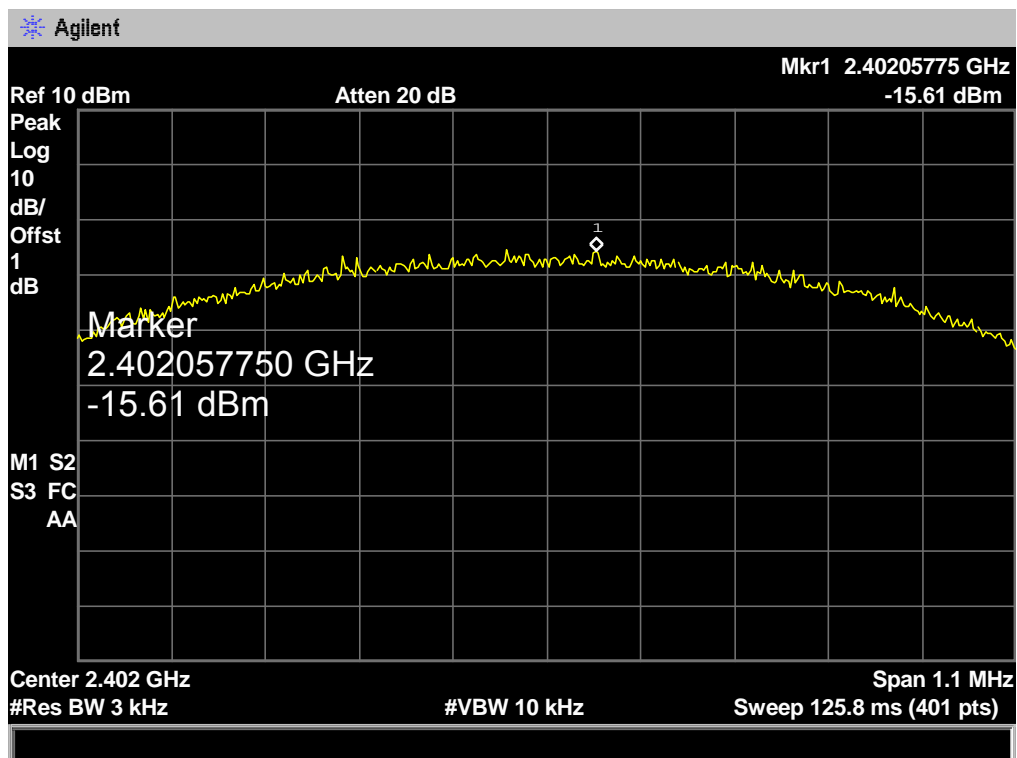

2442 MHz

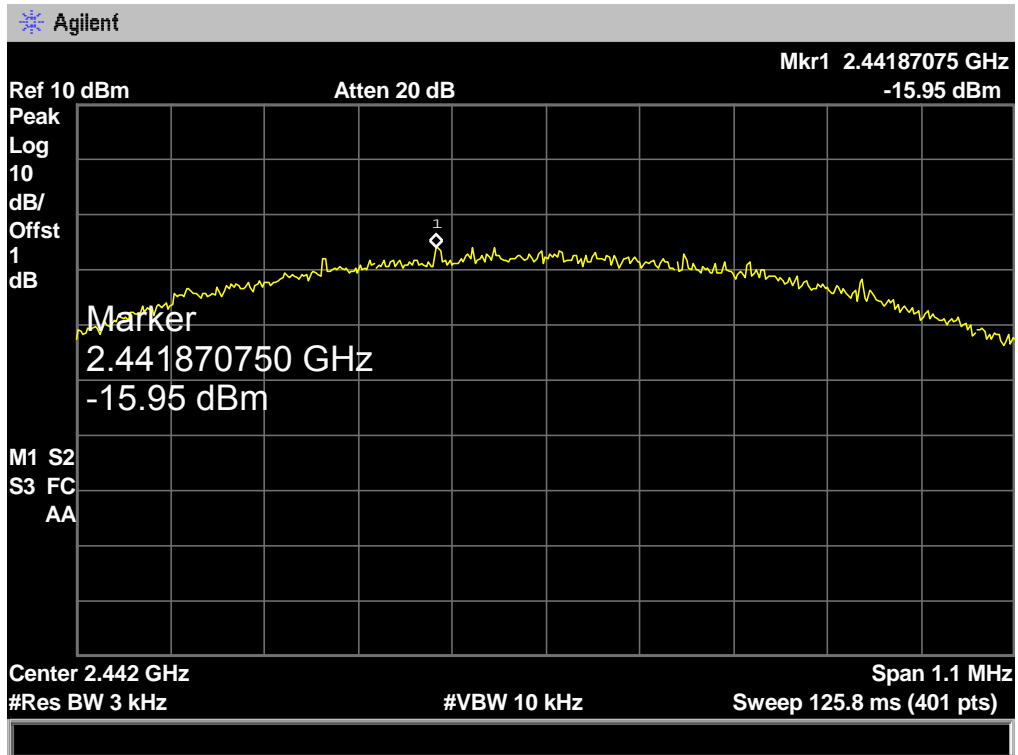

2480 MHz

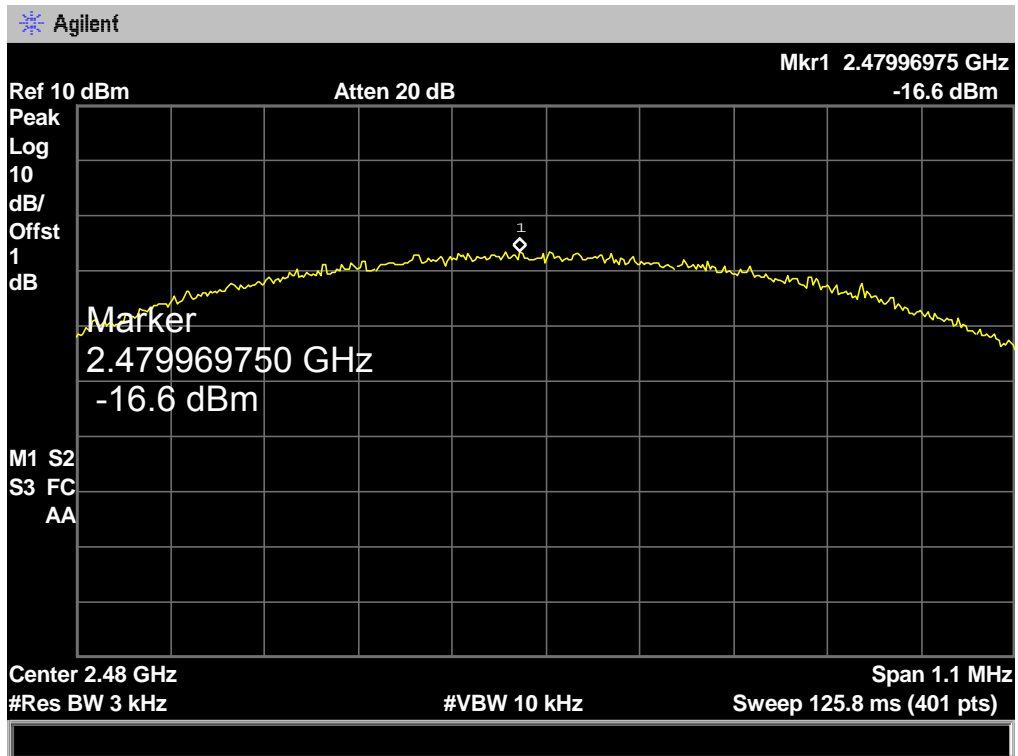

8. BAND EDGE AND OUT-OF-BAND EMISSION

8.1 LIMITS

FCC Part 15.247, Subpart C/ RSS 247 Section 5.5	
Frequency Range (MHz)	2400~2483.5
Limit	In any 100 kHz bandwidth outside the intentional radiation frequency band, the radio frequency power shall be at least 20 dB below the highest level of the desired power, based on either an RF conducted measurement, provide the transmitter demonstrates compliance with the peak conducted power limits.

8.2 TEST PROCEDURE

The EUT was directly connected to the Spectrum Analyzer and antenna output port as show in the block diagram as bellow.

- Set frequency range to capture low band-edge from 2310 MHz up to 2390 MHz, and for up band-edge from 2483.5 MHz up to 2500 MHz
- For low band-edge set the equipment transmit at the lowest channel, and for up band-edge set the equipment transmit at the highest channel
- Set the VBW ≥ 3 RBW (100kHz/ 300kHz) for conducted measurement
- For radiated measurements the RBW set to 1 MHz, and the VBW set to 1 MHz for peak measurements and 10 Hz for average measurement

8.3 TEST SETUP

(A) Radiated Emission Test Set-Up

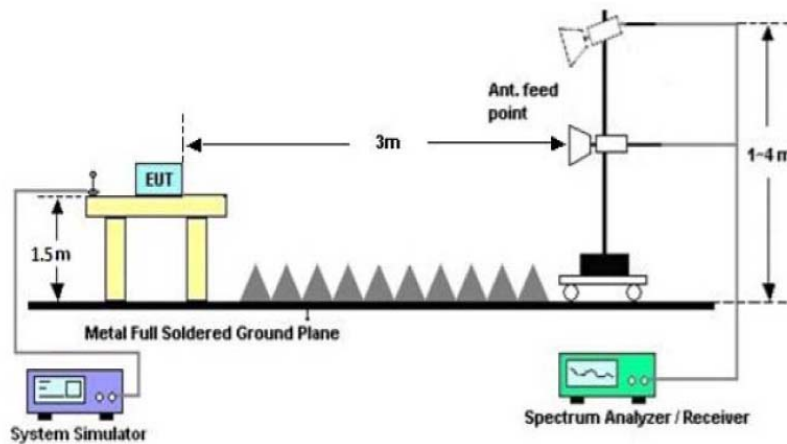

(B) Conducted Emission Test Setup

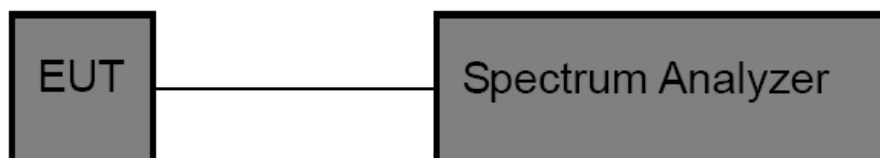

8.4 TEST INSTRUMENTS

Equipment	Manufacturer	Type No.	Serial No.	Last calibration	Calibrated until	Calibration period
Broadband Antenna	R&S	VULB 9168	VULB 9168-456	Jul. 04, 2016	Jul. 03. 2017	1 year
Test Cable	N/A	R-01	N/A	Jul. 04, 2016	Jul. 03. 2017	1 year
Test Cable	N/A	R-02	N/A	Jul. 04, 2016	Jul. 03. 2017	1 year
EMI Test Receiver	R&S	ESCI	101324	Jul. 04, 2016	Jul. 03. 2017	1 year
Spectrum Analyzer	Agilent	E4407B	MY41440432	Jul. 04, 2016	Jul. 03. 2017	1 year
Antenna Mast	EM	SC100_1	N/A	N/A	N/A	N/A
Turn Table	EM	SC100	060531	N/A	N/A	N/A
50Ω Switch	Anritsu Corp	MP59B	6200983705	Jul. 04, 2016	Jul. 03. 2017	1 year
Spectrum Analyzer	R&S	FSP40	100154	Jul. 04, 2016	Jul. 03. 2017	1 year
Horn Antenna	R&S	HF906	10029	Jul. 04, 2016	Jul. 03. 2017	1 year
Amplifier	EM	EM-30180	060538	Jul. 04, 2016	Jul. 03. 2017	1 year

8.5 EUT OPERATING CONDITIONS

The EUT was set to continuously transmitting in the maximum power during the test.

8.6 TEST RESULTS

Bandedge(Radiated Emission)

EUT :	Bluetooth headset	Model Name. :	L8
Temperature :	26 °C	Relative Humidity :	56%
Test Power :	DC 3.7V	Pressure :	1010 hPa
Test Mode :	BLE TX Mode 2402MHz	Test Date :	2017-06-26
Polarity :	Horizontal		
Remark :	Only show the worst polarity		

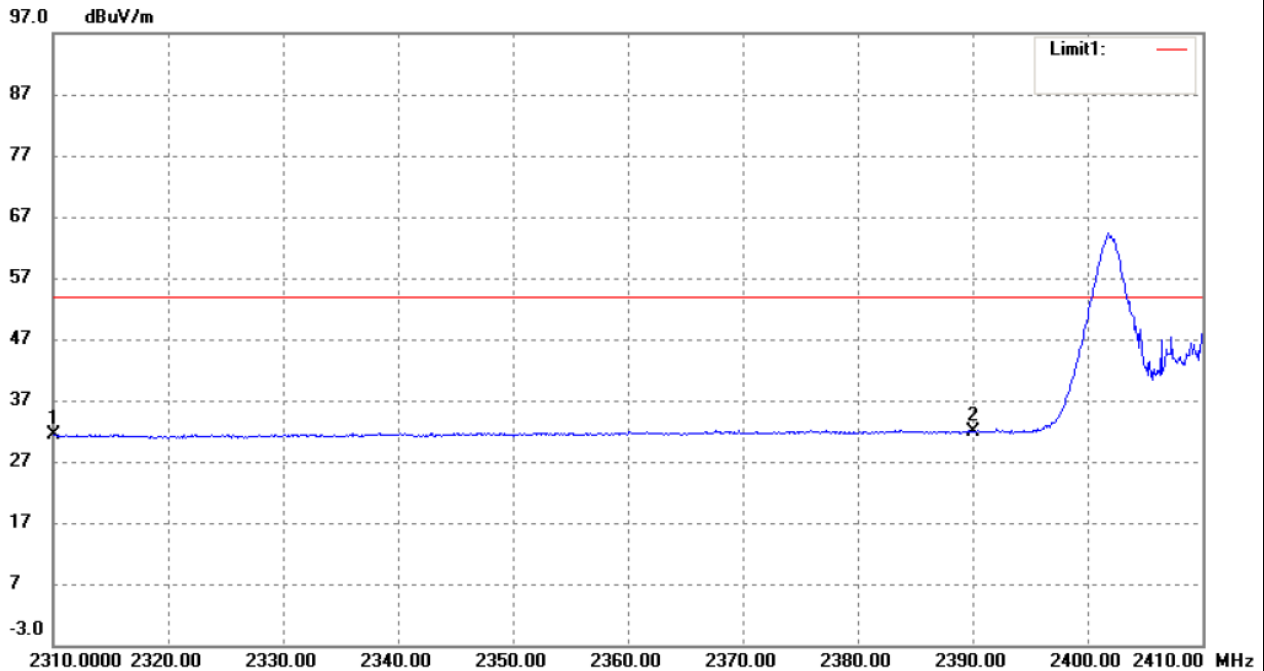

No.	Frequency (MHz)	Reading (dBuV/m)	Correct (dB/m)	Result (dBuV/m)	Limit (dBuV/m)	Margin (dB)	Remark
1	2310.000	35.09	-3.80	31.29	54.00	-22.71	Ave Detector
	2310.000	47.36	-3.80	43.56	74.00	-30.44	Peak Detector
2	2390.000	34.87	-3.00	31.87	54.00	-22.13	Ave Detector
	2390.000	54.62	-3.00	51.62	74.00	-22.38	Peak Detector

Remark:

Emission Level= Read Level+ Correct Factor

Margin= Emission Level-Limit

No report for the emission which more than 10 dB below the prescribed limit.

EUT :	Bluetooth headset	Model Name. :	L8
Temperature :	26 °C	Relative Humidity :	56%
Test Power :	DC 3.7V	Pressure :	1010 hPa
Test Mode :	BLE TX Mode 2480MHz	Test Date :	2017-06-26
Polarity :	Horizontal		
Remark :	Only show the worst polarity		

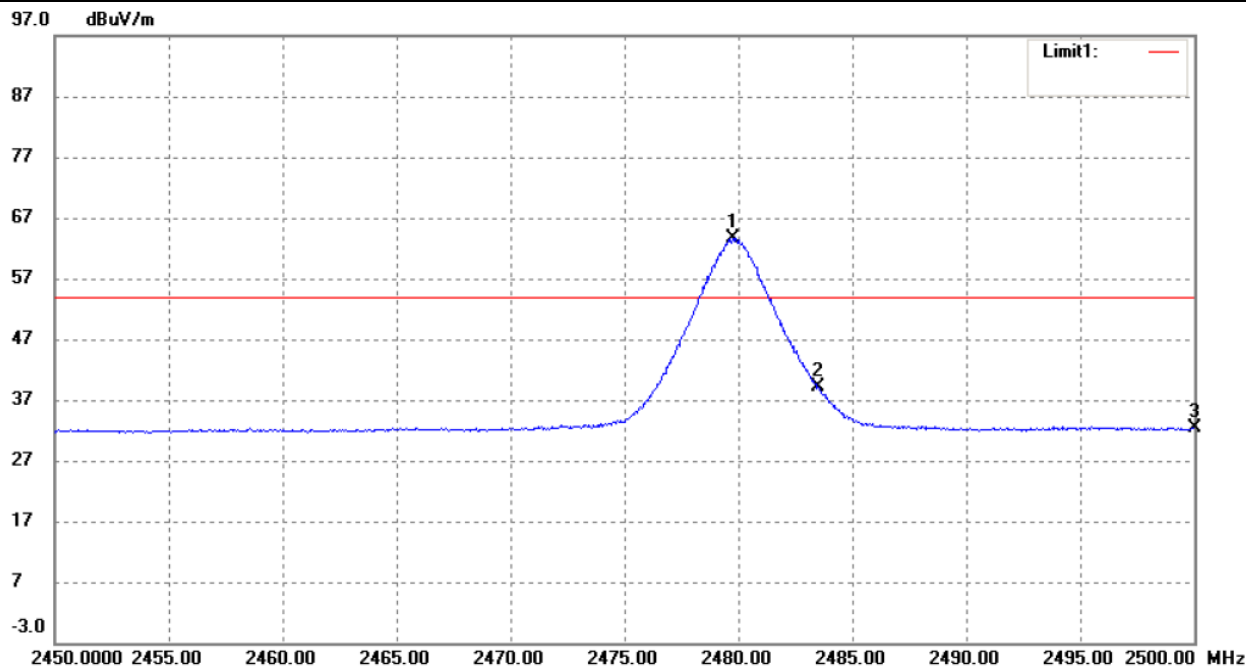

No.	Frequency (MHz)	Reading (dBuV/m)	Correct (dB/m)	Result (dBuV/m)	Limit (dBuV/m)	Margin (dB)	Remark
1	2479.750	66.22	-2.50	63.72	/	/	Ave Detector
	2479.950	89.88	-2.50	87.38	/	/	Peak Detector
2	2483.500	41.52	-2.49	39.03	54.00	-14.97	Ave Detector
	2483.500	70.83	-2.49	68.34	74.00	-5.66	Peak Detector
3	2500.000	34.71	-2.40	32.31	54.00	-21.69	Ave Detector
	2500.000	51.28	-2.40	48.88	74.00	-25.12	Peak Detector

Remark:

Emission Level= Read Level+ Correct Factor

Margin= Emission Level-Limit

No report for the emission which more than 10 dB below the prescribed limit.

Bandedge(Conducted Emission)

BLE Mode Low CH

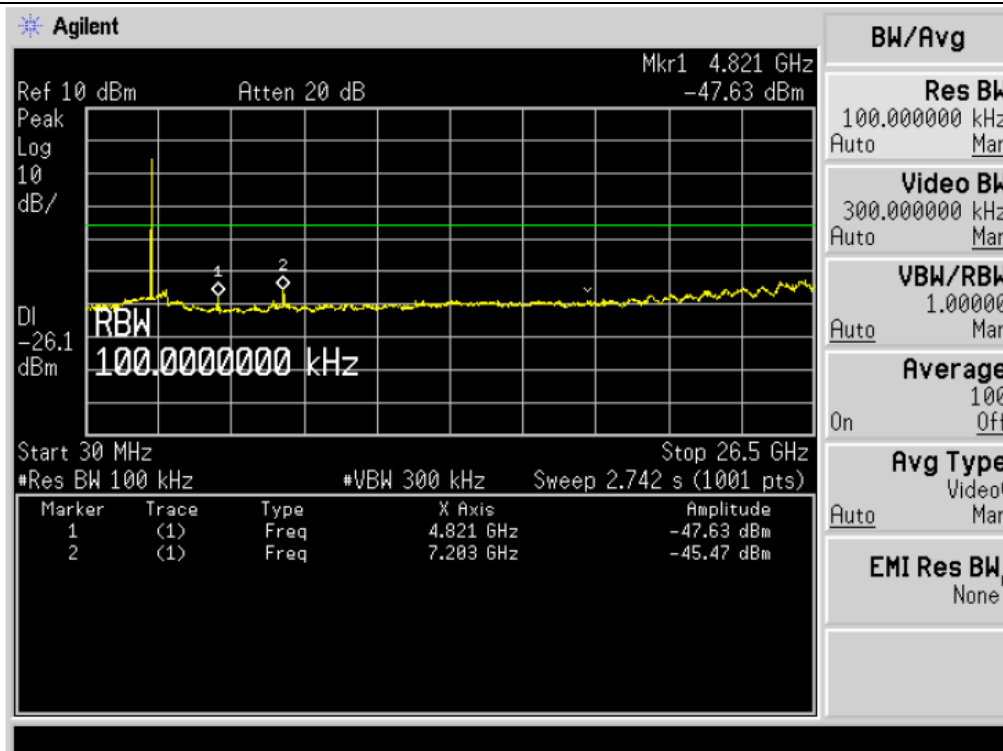

BLE Mode High CH

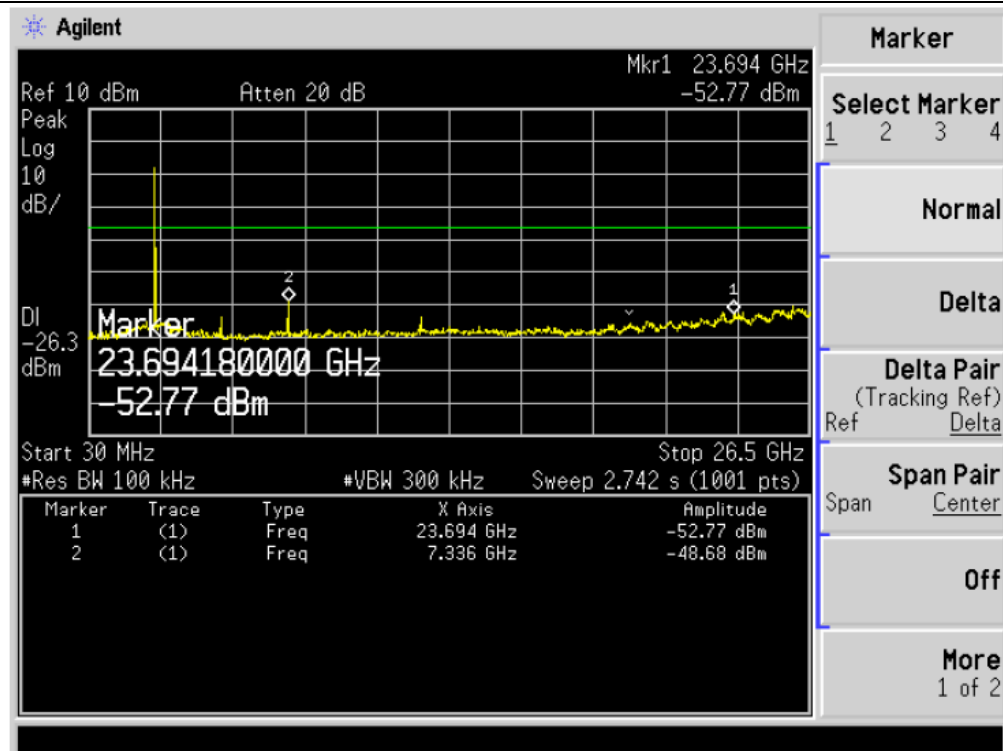

9. ANTENNA REQUIREMENT

9.1 REQUIREMENT

Antenna Requirement (15.203)	An intentional radiator shall be designed to ensure that no antenna other than that furnished by the responsible party shall be used with the device. The use of a permanently attached antenna or of an antenna that uses a unique coupling to the intentional radiator shall be considered sufficient to comply with the provisions of this Section. The manufacturer may design the unit so that a broken antenna can be replaced by the user, but the use of a standard antenna jack or electrical connector is prohibited.
Antenna Requirement (15.247)	If transmitting antennas of directional gain greater than 6 dBi are used, the power shall be reduced by the amount in dB that the directional gain of the antenna exceeds 6 dBi.

9.2 ANTENNA CONNECTOR CONSTRUCTION

The EUT antenna is a PCB Antenna. And the maximum gain of this antenna is 2dBi. It complies with the standard requirement.

-----END OF REPORT-----