



FCC Test Report

FCC ID: 2ALXA-C108

Product: Education Tablets
Trade Mark: N/A
Model Number: C108
Serial Model: Vexia Stronger Hey! C109
Report No.: NTEK- 2016NT12060429F4

Prepared for

CRAMBO S.A

AV DEL SOL 11, TORREJON DE ARDOZ 28850, MADRID, SPAIN.

Prepared by

NTEK Testing Technology Co., Ltd.

1/F, Building E, Fenda Science Park, Sanwei Community,
Xixiang Street Bao'an District, Shenzhen 518126 P.R. China

Tel.: +86-755-6115 6588

Fax.: +86-755-6115 6599

Website: <http://www.ntek.org.cn>

TEST RESULT CERTIFICATION

Applicant's name : CRAMBO S.A

Address..... : AV DEL SOL 11, TORREJON DE ARDOZ 28850, MADRID, SPAIN.

Manufacturer's Name : VEXIA

Address..... : AV DEL SOL 11, TORREJON DE ARDOZ 28850, MADRID, SPAIN.

Product description

Product name..... : Education Tablets

Model and/or type reference : C108

FCC Part15B:01 Oct.2016

Standards : ANSI C63.4:2014

This device described above has been tested by NTEK, and the test results show that the equipment under test (EUT) is in compliance with Part 15 of FCC Rules. And it is applicable only to the tested sample identified in the report.

This report shall not be reproduced except in full, without the written approval of NTEK, this document may be altered or revised by NTEK, personnel only, and shall be noted in the revision of the document.

Date of Test

Date (s) of performance of tests..... : 06 Dec. 2016 ~ 14 Apr. 2017

Date of Issue

14 Apr. 2017

Test Result..... : **Pass**

Testing Engineer :

Eileen Liu

(Eileen Liu)

Technical Manager :

Jason Chen

(Jason Chen)

Authorized Signatory :

Sam Chen

(Sam Chen)

Table of Contents	Page
1 . TEST SUMMARY	4
1.1 TEST FACILITY	5
1.2 MEASUREMENT UNCERTAINTY	5
2 . GENERAL INFORMATION	6
2.1 GENERAL DESCRIPTION OF EUT	6
2.2 DESCRIPTION OF TEST SETUP	8
2.3 DESCRIPTION TEST PERIPHERAL AND EUT PERIPHERAL	9
2.4 MEASUREMENT INSTRUMENTS LIST	10
3 . EMC EMISSION TEST	11
3.1 CONDUCTED EMISSION MEASUREMENT	11
3.1.1 POWER LINE CONDUCTED EMISSION	11
3.1.2 TEST PROCEDURE	12
3.1.3 TEST SETUP	12
3.1.4 EUT OPERATING CONDITIONS	12
3.1.5 TEST RESULTS	13
3.2 RADIATED EMISSION MEASUREMENT	15
3.2.1 LIMITS OF RADIATED EMISSION MEASUREMENT	15
3.2.2 TEST PROCEDURE	15
3.2.3 TEST SETUP	16
3.2.4 TEST RESULTS	17
3.2.5 TEST RESULTS(1000~6000MHz)	19
4 . EUT TEST PHOTO	20

1. TEST SUMMARY

Test procedures according to the technical standards:

EMC Emission				
Standard	Test Item	Limit	Judgment	Remark
FCC Part15B:2016 ANSI C63.4: 2014	Conducted Emission	Class B	PASS	
	Radiated Emission	Class B	PASS	

NOTE:

- (1) 'N/A' denotes test is not applicable in this Test Report
- (2) For client's request and manual description, the test will not be executed.

1.1 TEST FACILITY

NTEK Testing Technology Co., Ltd

Add. : 1/F, Building E, Fenda Science Park, Sanwei Community, Xixiang Street, Bao'an District, Shenzhen P.R. China.

FCC Registration Number:238937; IC Registration Number:9270A-1

CNAS Registration Number:L5516

1.2 MEASUREMENT UNCERTAINTY

The reported uncertainty of measurement $y \pm U$, where expanded uncertainty U is based on a standard uncertainty multiplied by a coverage factor of $k=2$, providing a level of confidence of approximately **95** %.

A. Conducted Measurement :

Test Site	Method	Measurement Frequency Range	U, (dB)	NOTE
NTEKC01	ANSI	150 KHz ~ 30MHz	3.2	

B. Radiated Measurement :

Test Site	Method	Measurement Frequency Range	U, (dB)	NOTE
NTEKA01	ANSI	30MHz ~ 1000MHz	4.7	
		1GHz ~12.4GHz	5.0	

2. GENERAL INFORMATION

2.1 GENERAL DESCRIPTION OF EUT

Equipment	Education Tablets	
Trade Mark	N/A	
Model Name	C108	
Serial Model	Vexia Stronger Hey! C109	
Model Difference	All the model are the same circuit and RF module, except the model No..	
Product Description	The EUT is a Education Tablets.	
	Connecting I/O port:	USB, DC in, HDMI, Micro USB
	Operation Frequency:	BT:2402~2480 MHz WIFI:802.11b/g/n(20MHz): 2412~2462MHz 802.11n(40MHz):2422~2452MHz 5.8 WIFI: 5745-5825 MHz for 802.11a/n(HT20)/AC20; 5755-5795 MHz for 802.11a/n(HT40)/AC40; 5775MHz for 802.11 AC80
Modulation Type:	BT(1Mbps)/BLE: GFSK BT EDR(2Mbps): $\pi/4$ -DQPSK BT EDR(3Mbps): 8-DPSK IEEE 802.11b : DSSS (CCK, QPSK, DBPSK) IEEE 802.11g/n (HT20/HT40) : OFDM (64QAM, 16QAM, QPSK, BPSK) OFDM with BPSK/QPSK/16QAM/64QAM/256QAM for 802.11a/n/ac	
Power Source	DC Voltage: DC 3.8V/8600mAh from Battery or DC 5V from adapter.	
Adapter	Model:JK050250-S04US Input:AC 100-240V 50/60Hz 0.5A Output:DC 5V,2500mA	
Battery	DC 3.8V, 8600mAh	
HW Version	CT108AC_CHT_V1.0	
SW Version	V1.0	

2.1.1 DESCRIPTION OF TEST MODES

To investigate the maximum EMI emission characteristics generates from EUT, the test system was pre-scanning tested base on the consideration of following EUT operation mode or test configuration mode which possible have effect on EMI emission level. Each of these EUT operation mode(s) or test configuration mode(s) mentioned above was evaluated respectively.

Pretest Mode	Description
Mode 1	Connect to PC
Mode 2	REC
Mode 3	BT
Mode 4	2.4G/5GWIFI
Mode 5	TF CARD

For Conducted Test	
Final Test Mode	Description
Mode 1	Connect to PC
Mode 2	REC
Mode 3	BT
Mode 4	WIFI
Mode 5	TF CARD

For Radiated Test	
Final Test Mode	Description
Mode 1	Connect to PC
Mode 2	REC
Mode 3	BT
Mode 4	2.4G/5GWIFI
Mode 5	TF CARD

Note: Final Test Mode: Through Pre-scan, find the mode 1 is the worst case. Only the worst case mode is recorded in the report.

2.2 DESCRIPTION OF TEST SETUP

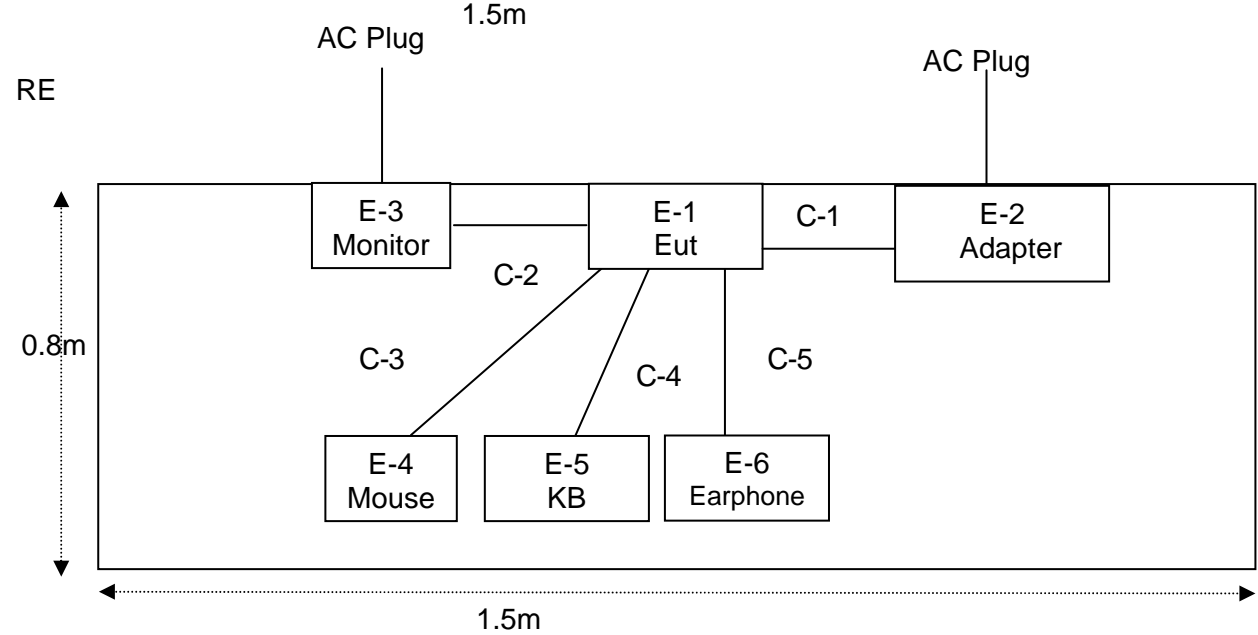
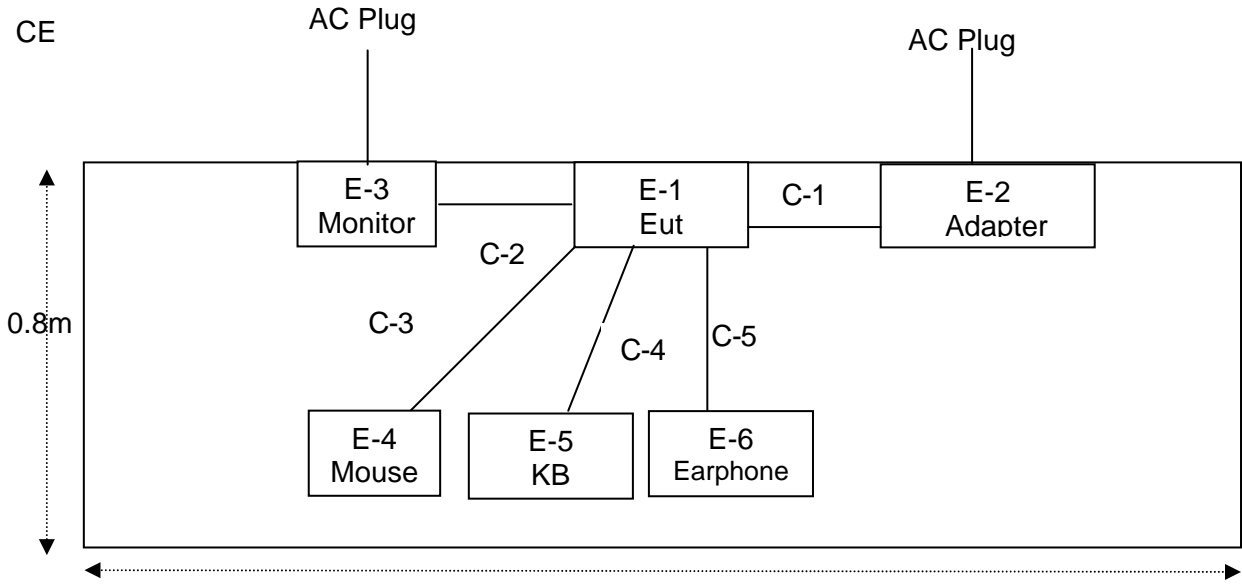

2.3 DESCRIPTION TEST PERIPHERAL AND EUT PERIPHERAL

The EUT has been tested as an independent unit together with other necessary accessories or support units. The following support units or accessories were used to form a representative test configuration during the tests.

Item	Equipment	Brand	Model/Type No.	Series No.	Note
E-1	Education Tablets	N/A	C108	N/A	EUT
E-2	Adapter	N/A	JK050250-S04US	N/A	
E-3	Monitor	DELL	IN2020MB	cn-0y6mhx-74261-11f-67es	Peripherals
E-4	Mouse	DELL	MS111-P	cn-011d3v-71581-11e-1th7	Peripherals
E-5	KB	DELL	SK-8185	OY526KUS	Peripherals
E-6	Earphone	N/A	L662	N/A	Peripherals

Item	Cable Type	Shielded Type	Ferrite Core	Length	Note
C-1	USB Cable	NO	NO	1.2m	
C-2	HDMI Cable	NO	NO	0.8m	
C-3	Mouse Cable	NO	NO	1.2m	
C-4	KB Cable	NO	NO	1.2m	
C-5	Earphone Cable	NO	NO	1.2m	

Note:

- (1) The support equipment was authorized by Declaration of Confirmation.
- (2) For detachable type I/O cable should be specified the length in cm in 『Length』 column.
- (3) “YES” means “shielded” “with core”; “NO” means “unshielded” “without core”.

2.4 MEASUREMENT INSTRUMENTS LIST

Radiation Test equipment

Item	Kind of Equipment	Manufacturer	Type No.	Serial No.	Last calibration	Calibrated until	Calibration period
1	Spectrum Analyzer	Agilent	E4407B	MY45108040	2016.07.06	2017.07.05	1 year
2	Test Receiver	R&S	ESPI	101318	2016.06.07	2017.06.06	1 year
3	Bilog Antenna	TESEQ	CBL6111D	31216	2016.07.06	2017.07.05	1 year
4	50Ω Coaxial Switch	Anritsu	MP59B	6200264416	2016.06.07	2017.06.06	1 year
5	Spectrum Analyzer	ADVANTEST	R3132	150900201	2016.06.07	2017.06.06	1 year
6	Horn Antenna	EM	EM-AH-10180	2011071402	2016.07.06	2017.07.05	1 year
7	Horn Ant	Schwarzbeck	BBHA 9170	9170-181	2016.07.06	2017.07.05	1 year
8	Amplifier	EM	EM-30180	060538	2016.07.06	2017.07.05	1 year
9	Loop Antenna	ARA	PLA-1030/B	1029	2016.06.08	2017.06.07	1 year
10	Power Meter	R&S	NRVS	100696	2016.07.06	2017.07.05	1 year
11	Power Sensor	R&S	URV5-Z4	0395.1619.05	2016.07.06	2017.07.05	1 year
12	Test Cable	N/A	R-01	N/A	2016.07.06	2017.07.05	1 year
13	Test Cable	N/A	R-02	N/A	2016.07.06	2017.07.05	1 year

Conduction Test equipment

Item	Kind of Equipment	Manufacturer	Type No.	Serial No.	Last calibration	Calibrated until	Calibration period
1	Test Receiver	R&S	ESCI	101160	2016.06.06	2017.06.05	1 year
2	LISN	R&S	ENV216	101313	2016.08.24	2017.08.23	1 year
3	LISN	EMCO	3816/2	00042990	2016.08.24	2017.08.23	1 year
4	50Ω Coaxial Switch	Anritsu	MP59B	6200264417	2016.06.07	2017.06.06	1 year
5	Passive Voltage Probe	R&S	ESH2-Z3	100196	2016.06.07	2017.06.06	1 year
6	Absorbing clamp	R&S	MOS-21	100423	2016.06.08	2017.06.07	1 year
7	Test Cable	N/A	C01	N/A	2016.06.08	2017.06.07	1 year
8	Test Cable	N/A	C02	N/A	2016.06.08	2017.06.07	1 year
9	Test Cable	N/A	C03	N/A	2016.06.08	2017.06.07	1 year

3. EMC EMISSION TEST

3.1 CONDUCTED EMISSION MEASUREMENT

3.1.1 POWER LINE CONDUCTED EMISSION (Frequency Range 150KHz-30MHz)

FREQUENCY (MHz)	Class A (dBuV)		Class B (dBuV)	
	Quasi-peak	Average	Quasi-peak	Average
0.15 -0.5	79.00	66.00	66 - 56 *	56 - 46 *
0.50 -5.0	73.00	60.00	56.00	46.00
5.0 -30.0	73.00	60.00	60.00	50.00

Note:

- (1) The tighter limit applies at the band edges.
- (2) The limit of " * " marked band means the limitation decreases linearly with the logarithm of the frequency in the range.

The following table is the setting of the receiver

Receiver Parameters	Setting
Attenuation	10 dB
Start Frequency	0.15 MHz
Stop Frequency	30 MHz
IF Bandwidth	9 kHz

3.1.2 TEST PROCEDURE

- a. The EUT was placed 0.8 meters from the horizontal ground plane with EUT being connected to the power mains through a line impedance stabilization network (LISN). All other support equipments powered from additional LISN(s). The LISN provide 50 Ohm/ 50uH of coupling impedance for the measuring instrument.
- b. Interconnecting cables that hang closer than 40 cm to the ground plane shall be folded back and forth in the center forming a bundle 30 to 40 cm long.
- c. I/O cables that are not connected to a peripheral shall be bundled in the center. The end of the cable may be terminated, if required, using the correct terminating impedance. The overall length shall not exceed 1 m.
- d. LISN at least 80 cm from nearest part of EUT chassis.
- e. For the actual test configuration, please refer to the related Item –EUT Test Photos.

3.1.3 TEST SETUP

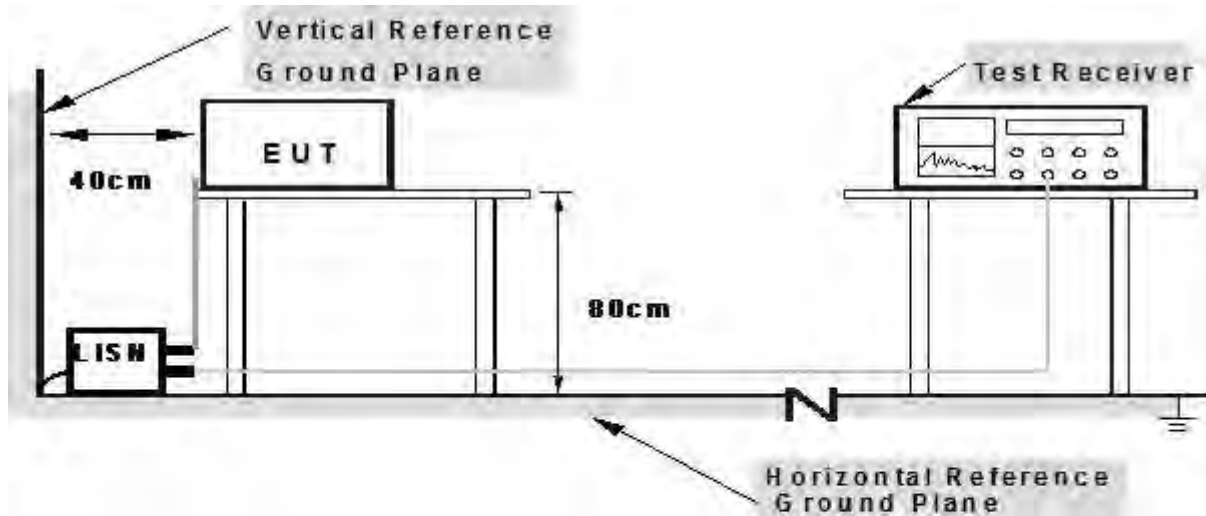

Note: 1. Support units were connected to second LISN.

2. Both of LISNs (AMN) are 80 cm from EUT and at least 80 cm from other units and other metal planes

3.1.4 EUT OPERATING CONDITIONS

The EUT tested system was configured as the statements of 2.3 Unless otherwise a special operating condition is specified in the follows during the testing.

3.1.5 TEST RESULTS

EUT:	Education Tablets	Model Name. :	C108
Temperature:	26 °C	Relative Humidity:	54%
Pressure:	1010hPa	Test Date:	2016-12-06
Test Mode:	Mode 1	Phase :	L
Test Voltage:	DC 5V from adapter AC 120V/60Hz		

Frequency (MHz)	Reading Level (dBμV)	Correct Factor (dB)	Measure-ment (dBμV)	Limits (dBμV)	Margin (dB)	Remark
0.1500	61.30	0.16	61.46	65.99	-4.53	QP
0.1500	48.39	0.16	48.55	55.99	-7.44	AVG
0.1980	58.35	0.13	58.48	63.69	-5.21	QP
0.1980	46.49	0.13	46.62	53.69	-7.07	AVG
0.2740	53.15	0.12	53.27	60.99	-7.72	QP
0.2740	38.16	0.12	38.28	50.99	-12.71	AVG
0.5100	48.92	0.14	49.06	56.00	-6.94	QP
0.5100	37.83	0.14	37.97	46.00	-8.03	AVG
3.0178	38.23	0.21	38.44	56.00	-17.56	QP
3.0178	26.01	0.21	26.22	46.00	-19.78	AVG
10.5259	42.29	0.29	42.58	60.00	-17.42	QP
10.5259	30.02	0.29	30.31	50.00	-19.69	AVG

Remark:

1. All readings are Quasi-Peak and Average values.
2. Factor = Insertion Loss + Cable Loss.

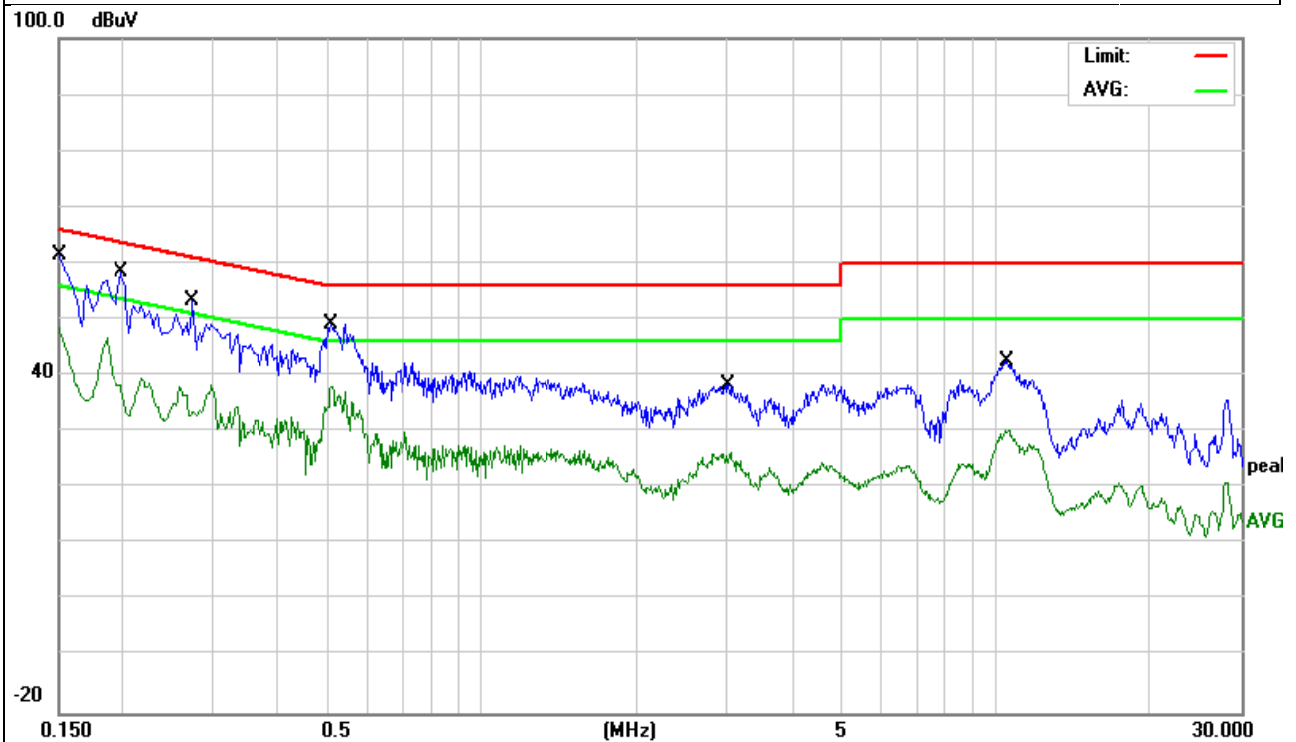

EUT:	Education Tablets	Model Name. :	C108
Temperature:	26 °C	Relative Humidity:	54%
Pressure:	1010hPa	Test Date:	2016-12-06
Test Mode:	Mode 1	Phase :	N
Test Voltage:	DC 5V from adapter AC 120V/60Hz		

Frequency (MHz)	Reading Level (dBμV)	Correct Factor (dB)	Measure-ment (dBμV)	Limits (dBμV)	Margin (dB)	Remark
0.1500	58.72	0.16	58.88	65.99	-7.11	QP
0.1500	48.86	0.16	49.02	55.99	-6.97	AVG
0.1980	57.64	0.13	57.77	63.69	-5.92	QP
0.1980	43.33	0.13	43.46	53.69	-10.23	AVG
0.2939	52.96	0.12	53.08	60.41	-7.33	QP
0.2939	35.35	0.12	35.47	50.41	-14.94	AVG
0.5220	49.49	0.15	49.64	56.00	-6.36	QP
0.5220	38.59	0.15	38.74	46.00	-7.26	AVG
1.6140	39.46	0.19	39.65	56.00	-16.35	QP
1.6140	27.22	0.19	27.41	46.00	-18.59	AVG
11.3338	39.38	0.31	39.69	60.00	-20.31	QP
11.3338	27.08	0.31	27.39	50.00	-22.61	AVG

Remark:

1. All readings are Quasi-Peak and Average values.
2. Factor = Insertion Loss + Cable Loss.

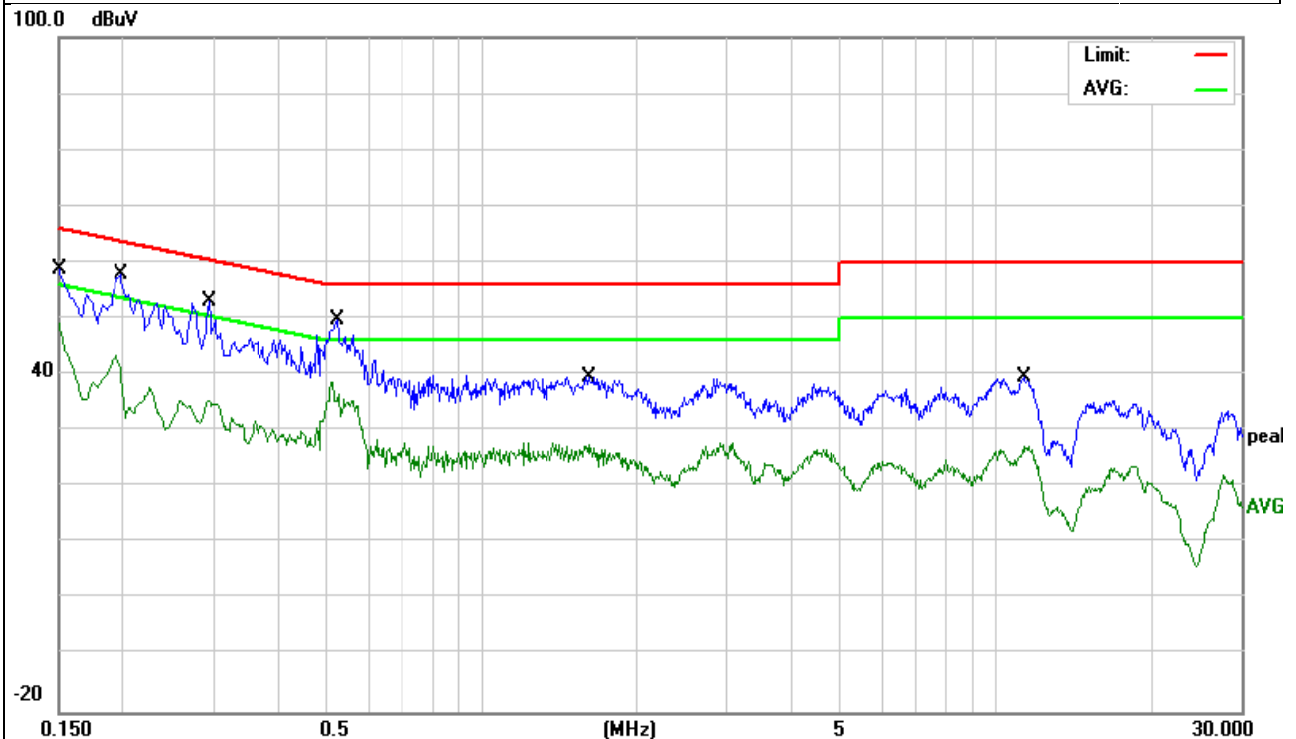

3.2 RADIATED EMISSION MEASUREMENT

3.2.1 LIMITS OF RADIATED EMISSION MEASUREMENT

FREQUENCY (MHz)	Class A (at 10m)	Class B (at 3m)
	dBuV/m	dBuV/m
30 ~ 88	39.0	40.0
88 ~ 216	43.5	43.5
216 ~ 960	46.5	46.0
Above 960	49.5	54.0

Notes:

- (1) The limit for radiated test was performed according to as following:
FCC PART 15B /ICES-003.
- (2) The tighter limit applies at the band edges.
- (3) Emission level (dBuV/m)=20log Emission level (uV/m).

3.2.2 TEST PROCEDURE

Test Arrangement for Radiated Emissions up to 1 GHz

- a. The EUT was placed on the top of a rotating table 0.8 meters above the ground at an accredited test facility. The table was rotated 360 degrees to determine the position of the highest radiation.
- b. The EUT was set 3 meters away from the interference-receiving antenna, which was mounted on the top of a variable-height antenna tower.
- c. The antenna is a broadband antenna, and its height is varied from one meter to four meters above the ground to determine the maximum value of the field strength. Both horizontal and vertical polarizations of the antenna are set to make the measurement.
- d. For each suspected emission, the EUT was arranged to its worst case and then the antenna was tuned to heights from 1 meter to 4 meters and the rotatable table was turned from 0 degrees to 360 degrees to find the maximum reading.

Note: The resolution bandwidth and video bandwidth of test receiver/spectrum analyzer is 120kHz for quasi-peak detection (QP) at frequency below 1GHz.

Test Arrangement for Radiated Emissions above 1 GHz.

- a. The EUT was placed on the top of a rotating table 0.8 meters above the ground at an accredited chamber room. The table was rotated 360 degrees to determine the position of the highest radiation.
- b. The EUT was set 3 meters away from the interference-receiving antenna, which was mounted on the top of a variable-height antenna tower.
- c. The height of antenna can be varied from one meter to four meters, the height of adjustment depends on the EUT height and the antenna 3dB beamwidth both, to detect the maximum value of the field strength.Both horizontal and vertical polarizations of the antenna are set to make the measurement.
- d. For each suspected emission, the EUT was arranged to its worst case and then the antenna was tuned to heights and the rotatable table was turned from 0 degrees to 360 degrees to find the maximum reading.

Note: For the hand-held device, the EUT should be measured for all 3 axes and only the worst case is recorded in the report
 During the radiated emission test, the Spectrum Analyzer was set with the following configurations:

Frequency Band (MHz)	Function	Resolution bandwidth	Video Bandwidth
30 to 1000	QP	120 kHz	300 kHz
Above 1000	Peak	1 MHz	1 MHz
	Avg	1 MHz	10 Hz

3.2.3 TEST SETUP

For Radiated Emission 30~1000MHz

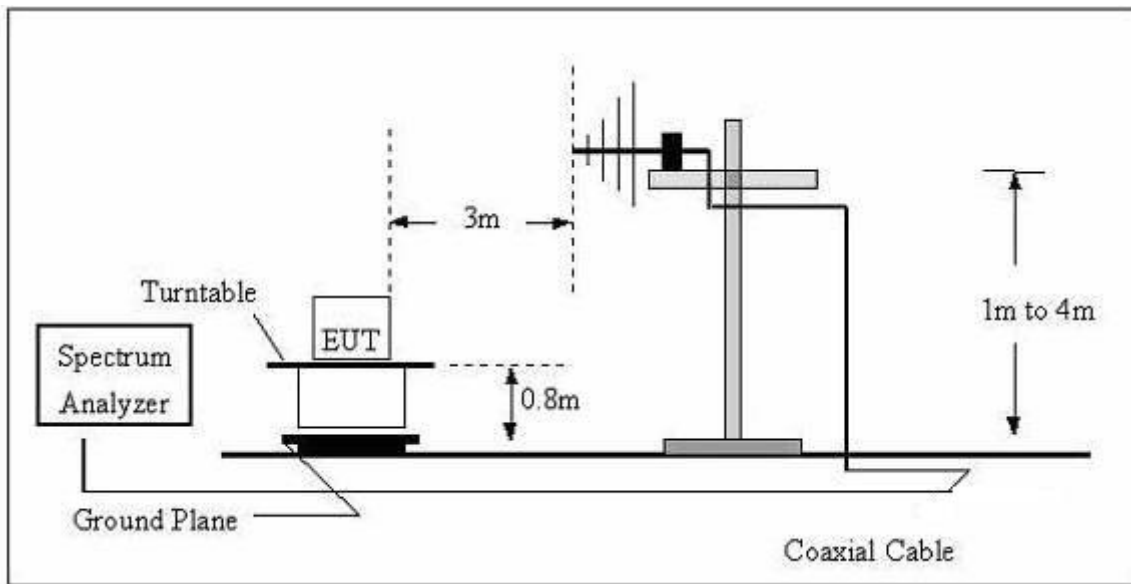

(B) Radiated Emission Test Set-Up Frequency Above 1GHz

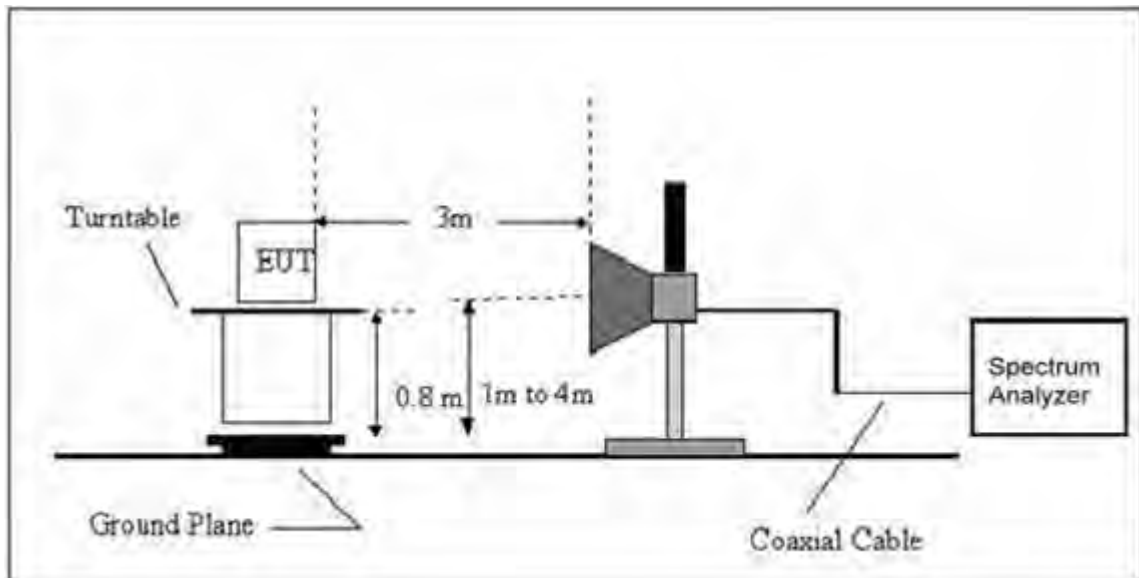

3.2.4 TEST RESULTS

TEST RESULTS (30~1000 MHz)

EUT:	Education Tablets	Model Name:	C108
Temperature:	24 °C	Relative Humidity:	54%
Pressure:	1010 hPa	Test Date :	2016-12-06
Test Mode :	Mode 1	Polarization :	Horizontal
Test Power :	DC 5V from adapter AC 120V/60Hz		

Polar (H/V)	Frequency	Meter Reading	Factor	Emission Level	Limits	Margin	Remark
	(MHz)	(dBuV)	(dB)	(dBuV/m)	(dBuV/m)	(dB)	
H	62.4314	22.04	6.35	28.39	40.00	-11.61	QP
H	99.8777	18.09	11.87	29.96	43.50	-13.54	QP
H	199.9856	24.02	10.26	34.28	43.50	-9.22	QP
H	318.8170	24.06	16.85	40.91	46.00	-5.09	QP
H	501.1790	15.47	21.45	36.92	46.00	-9.08	QP
H	1000.0000	7.51	31.05	38.56	54.00	-15.44	QP

Remark:
Factor = Antenna Factor + Cable Loss - Amplifier.

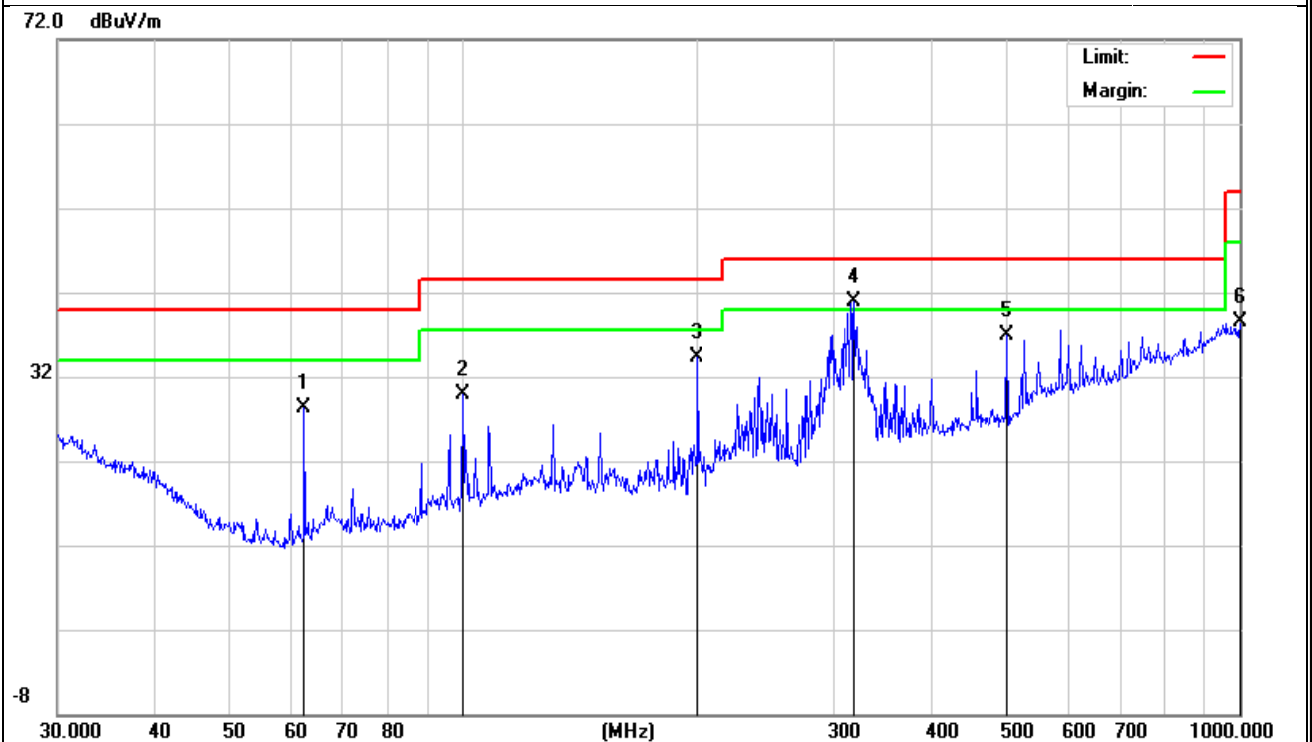

EUT:	Education Tablets	Model Name :	C108
Temperature:	24 °C	Relative Humidity:	54%
Pressure:	1010 hPa	Test Date :	2016-12-06
Test Mode :	Mode 1	Polarization :	Vertical
Test Power :	DC 5V from adapter AC 120V/60Hz		

Polar (H/V)	Frequency	Meter Reading	Factor	Emission Level	Limits	Margin	Remark
	(MHz)	(dBuV)	(dB)	(dBuV/m)	(dBuV/m)	(dB)	
V	30.0000	14.75	19.88	34.63	40.00	-5.37	QP
V	149.4857	17.42	13.06	30.48	43.50	-13.02	QP
V	312.1792	20.50	16.65	37.15	46.00	-8.85	QP
V	528.2458	11.52	23.36	34.88	46.00	-11.12	QP
V	622.8900	15.20	24.98	40.18	46.00	-5.82	QP
V	937.8326	5.40	30.93	36.33	46.00	-9.67	QP

Remark:

Factor = Antenna Factor + Cable Loss - Amplifier.

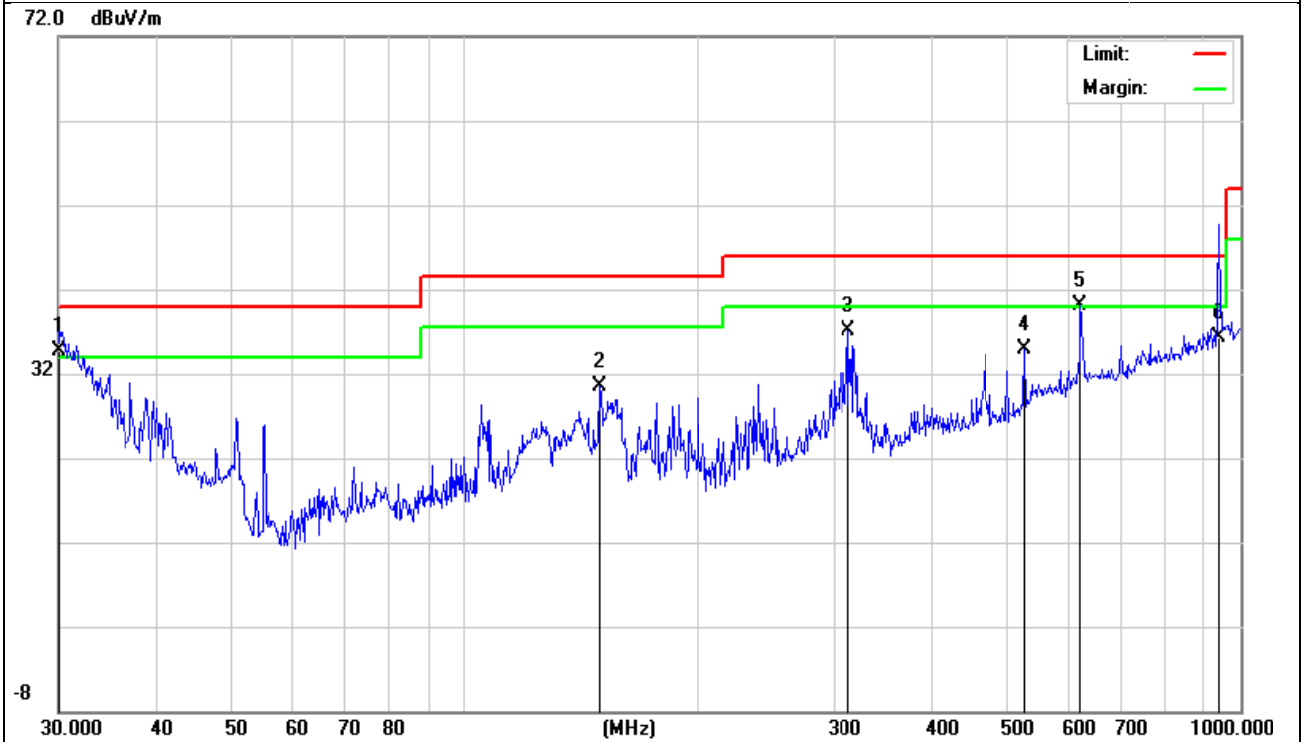

3.2.5 TEST RESULTS(1000~6000MHz)

EUT:	Education Tablets	Model Name :	C108
Temperature:	24 °C	Relative Humidity:	54%
Pressure:	1010 hPa	Test Date :	2016-12-06
Test Mode :	Mode 1		
Test Power :	DC 5V from adapter AC 120V/60Hz		

All the modulation modes have been tested, and the worst result was report as below:

Polar (H/V)	Frequency	Reading	Correct	Result	Limit	Over Limit	Remark
	(MHz)	(dBuV/m)	dB/m	(dBuV/m)	(dBuV/m)	(dB)	
V	2188.024	43.54	-9.84	33.7	74	-40.3	Pk
V	2188.024	31.16	-9.84	21.32	54	-32.7	AV
V	3659.161	41.75	-5.13	36.62	74	-37.4	Pk
V	3659.161	30.69	-5.13	25.56	54	-28.4	AV
H	2092.177	42.81	-9.93	32.88	74	-41.1	Pk
H	2092.177	31.75	-9.93	21.82	54	-32.2	AV
H	3973.53	41.21	-3.64	37.57	74	-36.4	Pk
H	3973.53	30.16	-3.64	26.52	54	-27.5	AV

Remark:

Absolute Level= ReadingLevel+ Factor, Margin= Absolute Level - Limit

Note: Only the worst results data points are reported in the report.

4. EUT TEST PHOTO

Radiated Measurement Photos

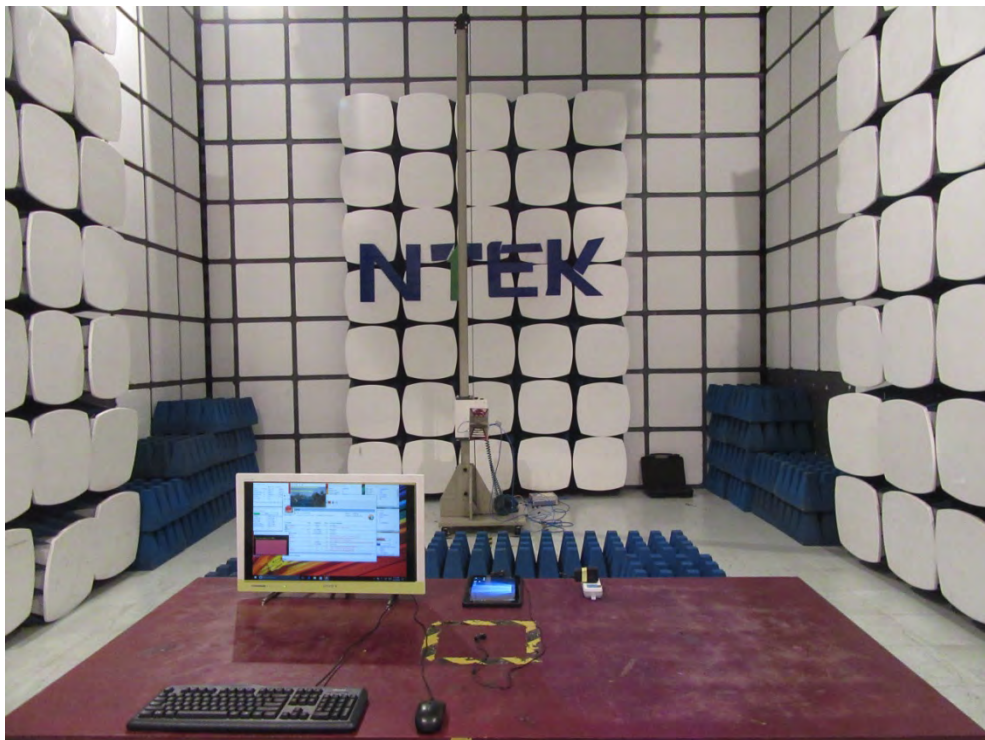
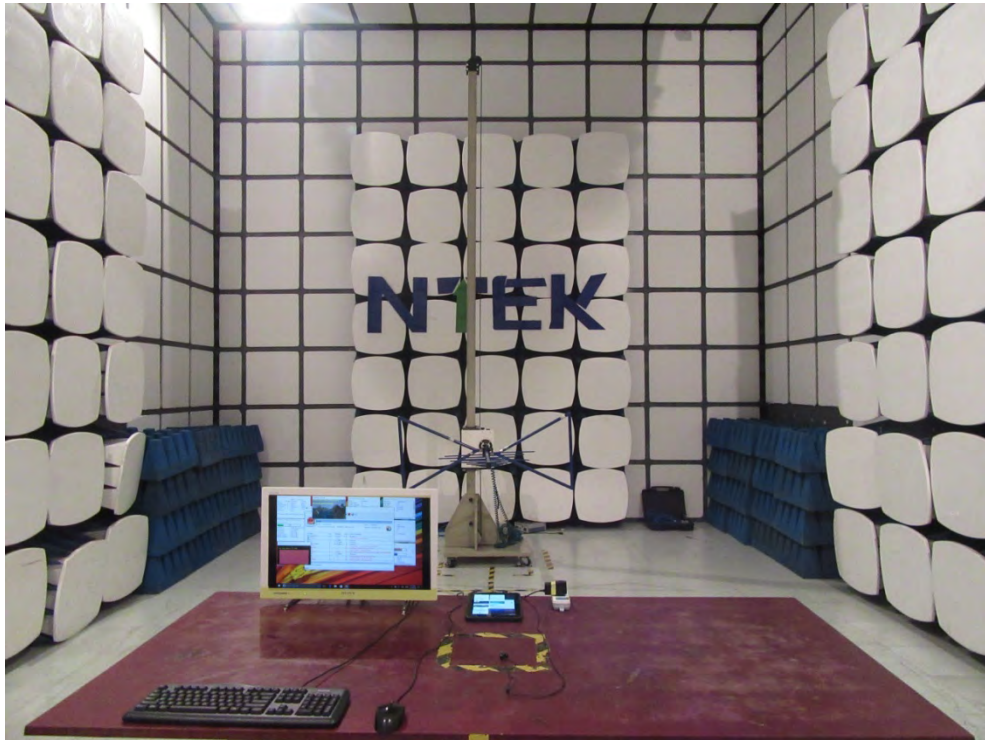

Conducted Measurement Photos

