

# **FCC Part 15 Subpart C Test Report**

## **for DSSS System**

**Product Name : 3G/2G fixed wireless phone**  
**Model Name : F800C**

Prepared for:

**CO-COMM SERVICIOS TELECOMUNICACIONES S.L.**  
**C/Lisboa, 20 – 28232 Las Rozas (Madrid), Spain.**  
**TEL: (+34) 981 553233**  
**FAX: (+34) 981 553054**

Prepared by:

**Unilab (Shanghai) Co., Ltd**  
**FCC 2.948 register number is 714465**  
**No.1350, Lianxi Rd. Pudong New District, Shanghai, China**  
**TEL: +86-21-50275125**  
**FAX: +86-21-50275126**

**Report Number : UL47120170105FCC001-03**  
**Date of Report : 02-07-2017**  
**Date of Test : 01-05-2017~01-23-2017**

**Notes :**

The test results only relate to these samples which have been tested.  
Partly using this report will not be admitted unless been allowed by Unilab.  
Unilab is only responsible for the complete report with the reported stamp of Unilab.

**Applicant:** CO-COMM SERVICIOS TELECOMUNICACIONES S.L.  
C/Lisboa, 20 – 28232 Las Rozas (Madrid), Spain.

**Manufacturer:** CO-COMM SERVICIOS TELECOMUNICACIONES S.L.  
C/Lisboa, 20 – 28232 Las Rozas (Madrid), Spain.

**Product Name:** 3G/2G fixed wireless phone

**Brand Name:** CO-COMM

**Model Name:** F800

**FCC ID:** 2AKWZF800C

**EUT Voltage:** Extreme Low:3.5V Nominal:3.7V Extreme High:4.2V

**Date of Receipt:** 01-05-2017

**Date of Test:** 01-05-2017~01-23-2017

**Test Standard:** FCC CFR Title 47 Part 15 Subpart C  
ANSI C 63.4: 2014  
ANSI C 63.10: 2013  
KDB 558074 D01 v03r05

**Test Result:** PASS

Prepared by : Wayne Wu  
(Technical Engineer: Wayne Wu)

Reviewed by : Forest Cao  
(Senior Engineer: Forest Cao)

Approved by : Eva Wang  
(Supervisor: Eva Wang)

## TABLE OF CONTENTS

<b>1.</b>	<b>GENERAL INFORMATION .....</b>	<b>5</b>
1.1	EUT DESCRIPTION .....	5
1.2	TEST MODE .....	5
<b>2.</b>	<b>TEST METHODOLOGY .....</b>	<b>5</b>
2.1	EUT CONFIGURATION .....	6
2.2	EUT EXERCISE .....	6
2.3	GENERAL TEST PROCEDURES .....	6
2.4	FCC PART 15.205 RESTRICTED BANDS OF OPERATIONS .....	6
2.5	Restricted Frequency Bands of RSS-GEN .....	7
<b>3.</b>	<b>TECHNIACL SUMMARY .....</b>	<b>7</b>
3.1	SUMMARY OF STANDARDS AND TEST RESULTS .....	7
3.2	TEST UNCERTAINTY .....	8
3.3	TEST EQUIPMENT LIST .....	8
3.4	TEST FACILITY .....	8
3.5	TEST SETUP CONFIGURATION .....	9
<b>4.</b>	<b>6 DB BANDWIDTH .....</b>	<b>9</b>
4.1	TEST SETUP .....	9
4.2	LIMITS .....	10
4.3	TEST PROCEDURE .....	10
4.4	RESULTS & PERFORMANCE .....	11
<b>5.</b>	<b>POWER SPECTRAL DENSITY .....</b>	<b>13</b>
5.1	TEST SETUP .....	13
5.2	LIMITS .....	13
5.3	TEST PROCEDURE .....	13
5.4	RESULTS & PERFORMANCE .....	14
<b>6.</b>	<b>PEAK OUTPUT POWER (CONDUCTION) .....</b>	<b>16</b>
6.1	TEST SETUP .....	16
6.2	LIMITS .....	16
6.3	TEST PROCEDURE .....	16
6.4	RESULTS & PERFORMANCE .....	16
<b>7.</b>	<b>SPURIOUS EMISSIONS (CONDUCTION) .....</b>	<b>17</b>
7.1	TEST SETUP .....	17
7.2	LIMITS .....	17
7.3	TEST PROCEDURE .....	17
7.4	RESULTS & PERFORMANCE .....	18
<b>8.</b>	<b>BAND EDGE MEASUREMENT .....</b>	<b>26</b>
8.1	TEST SETUP .....	26
8.2	LIMITS .....	26
8.3	TEST PROCEDURE .....	26
8.4	RESULTS & PERFORMANCE .....	27
<b>9.</b>	<b>SPURIOUS EMISSIONS (RADIATION) .....</b>	<b>36</b>
9.1	TEST SETUP .....	36
9.2	LIMITS .....	37
9.3	TEST PROCEDURE .....	37
9.4	RESULTS & PERFORMANCE .....	39
<b>10.</b>	<b>AC POWER LINE CONDUCTED EMISSIONS .....</b>	<b>46</b>
10.1	TEST SETUP .....	46

<b>10.2</b>	<b>LIMITS .....</b>	<b>46</b>
<b>10.3</b>	<b>TEST PROCEDURE .....</b>	<b>46</b>
<b>10.4</b>	<b>RESULTS &amp; PERFORMANCE .....</b>	<b>46</b>
<b>APPENDIX 1</b>	<b>PHOTOGRAPHS OF TEST SETUP.....</b>	<b>53</b>
<b>APPENDIX 2</b>	<b>PHOTOGRAPHS OF EUT .....</b>	<b>53</b>

## 1. GENERAL INFORMATION

### 1.1 EUT DESCRIPTION

Product Name:	3G/2G fixed wireless phone
Model Name:	F800C
Hardware Version:	F800C57v1.0
Software Version:	F800C57v000.1.0
RF Exposure Environment:	Uncontrolled
<b>BT 4.1 LE</b>	
Frequency Range:	2402MHz~2480MHz
Type of Modulation:	GFSK
Channel Number:	40
Antenna Type:	Internal
Antenna Peak Gain:	3.1dBi

### 1.2 TEST MODE

Unilab has verified the construction and function in typical operation. All the test modes were carried out with the EUT in normal operation, which was shown in this test report is the worst test mode and defined as:

Test Mode	Test Voltage
Mode 1: Bluetooth V4.1 LE:GFSK	AC 115V / 60Hz

Note:

1. Regards to the frequency band operation: the lowest, middle and highest frequency of channel were selected to perform the test, then shown on this report.
2. For the radiated emission test, every axis (X, Y, Z) was verified, and show the worst result on this report.

## 2. TEST METHODOLOGY

The tests documented in this report were performed in accordance with ANSI C63.4 and FCC CFR 47 2.1046, 2.1047, 2.1049, 2.1051, 2.1053, 2.1055, 2.1057, 15.207, 15.209 and 15.247.

**2.1 EUT CONFIGURATION**

The EUT configuration for testing is installed on RF field strength measurement to meet the Commissions requirement and operating in a manner that intends to maximize its emission characteristics in a continuous normal application

**2.2 EUT EXERCISE**

The EUT was operated in the engineering mode to fix the TX frequency that was for the purpose of the measurements. According to its specifications, the EUT must comply with the requirements of the Section 15.207, 15.209 and 15.247 under the FCC Rules Part 15 Subpart C.

**2.3 GENERAL TEST PROCEDURES**

**Conducted Emissions**

The EUT is placed on the turntable, which is 0.8 m above ground plane. According to the requirements in Section 13.1.4.1 of ANSI C63.4: 2014 Conducted emissions from the EUT measured in the frequency range between 0.15 MHz and 30MHz using CISPR Quasi-peak and average detector modes.

**Radiated Emissions**

The EUT is placed on a turn table, which is 0.8 m above ground plane. The turntable shall rotate 360 degrees to determine the position of maximum emission level. EUT is set 3m away from the receiving antenna, which varied from 1m to 4m to find out the highest emission. And also, each emission was to be maximized by changing the polarization of receiving antenna both horizontal and vertical. In order to find out the maximum emissions, exploratory radiated emission measurements were made according to the requirements in Section 13.1.4.1 of ANSI C63.4: 2014.

**2.4 FCC PART 15.205 RESTRICTED BANDS OF OPERATIONS**

(a) Except as shown in paragraph (d) of this section, only spurious emissions are permitted in any of the frequency bands listed below:

MHz	MHz	MHz	GHz
0.090 - 0.110	16.42 - 16.423	399.9 - 410	4.5 - 5.15
1 <sup>0</sup> .495 - 0.505	16.69475 - 16.69525	608 - 614	5.35 - 5.46
2.1735 - 2.1905	16.80425 - 16.80475	960 - 1240	7.25 - 7.75
4.125 - 4.128	25.5 - 25.67	1300 - 1427	8.025 - 8.5
4.17725 - 4.17775	37.5 - 38.25	1435 - 1626.5	9.0 - 9.2
4.20725 - 4.20775	73 - 74.6	1645.5 - 1646.5	9.3 - 9.5
6.215 - 6.218	74.8 - 75.2	1660 - 1710	10.6 - 12.7
6.26775 - 6.26825	108 - 121.94	1718.8 - 1722.2	13.25 - 13.4
6.31175 - 6.31225	123 - 138	2200 - 2300	14.47 - 14.5
8.291 - 8.294	149.9 - 150.05	2310 - 2390	15.35 - 16.2
8.362 - 8.366	156.52475 - 156.52525	2483.5 - 2500	17.7 - 21.4
8.37625 - 8.38675	156.7 - 156.9	2655 - 2900	22.01 - 23.12
8.41425 - 8.41475	162.0125 - 167.17	3260 - 3267	23.6 - 24.0
12.29 - 12.293	167.72 - 173.2	3332 - 3339	31.2 - 31.8
12.51975 - 12.52025	240 - 285	3345.8 - 3358	36.43 - 36.5
12.57675 - 12.57725	322 - 335.4	3600 - 4400	( <sup>2</sup> )

13.36 - 13.41			
---------------	--	--	--

1 Until February 1, 1999, this restricted band shall be 0.490-0.510 MHz.

2 Above 38.6

(b) Except as provided in paragraphs (d) and (e), the field strength of emissions appearing within these frequency bands shall not exceed the limits shown in Section 15.209. At frequencies equal to or less than 1000 MHz, compliance with the limits in Section 15.209 shall be demonstrated using measurement instrumentation employing a CISPR quasi-peak detector. Above 1000 MHz, compliance with the emission limits in Section 15.209 shall be demonstrated based on the average value of the measured emissions. The provisions in Section 15.35 apply to these measurements.

## 2.5 Restricted Frequency Bands of RSS-GEN

Restricted bands, identified in Table 6, are designated primarily for safety-of-life services (distress calling and certain aeronautical bands), certain satellite downlinks, radio astronomy and some government uses. Except where otherwise indicated, the following restrictions apply:

(a) Fundamental components of modulation of licence-exempt radio apparatus shall not fall within the restricted bands of Table 6 except for apparatus complying under RSS-287;

(b) Unwanted emissions that fall into restricted bands of Table below shall comply with the limits specified in RSS-Gen; and

(c) Unwanted emissions that do not fall within the restricted frequency bands of Table 6 shall comply either with the limits specified in the applicable RSS or with those specified in this RSS-Gen.

MHz	MHz	MHz	MHz	GHz
0.090-0.110	8.37625-8.38675	74.8-75.2	1718.8-1722.2	9.0-9.2
2.1735-2.1905	8.41425-8.41475	108-138	2200-2300	9.3-9.5
3.020-3.026	12.29-12.293	156.52475-156.52525	2310-2390	10.6-12.7
4.125-4.128	12.51975-12.52025	156.7-156.9	2655-2900	13.25-13.4
4.17725-4.17775	12.57675-12.57725	240-285	3260-3267	14.47-14.5
4.20725-4.20775	13.36-13.41	322-335.4	3332-3339	15.35-16.2
5.677-5.683	16.42-16.423	399.9-410	3345.8-3358	17.7-21.4
6.215-6.218	16.69475-16.69525	608-614	3500-4400	22.01-23.12
6.26775-6.26825	16.80425-16.80475	960-1427	4500-5150	23.6-24.0
6.31175-6.31225	25.5-25.67	1435-1626.5	5350-5460	31.2-31.8
8.291-8.294	37.5-38.25	1645.5-1646.5	7250-7750	36.43-36.5
8.362-8.366	73-74.6	1660-1710	8025-8500	Above 38.6

\* Certain frequency bands listed in Table 6 and in bands above 38.6 GHz are designated for licence-exempt applications. These frequency bands and the requirements that apply to the devices are set out in the 200- and 300-series of RSSs, such as RSS-210 and RSS-310, which contain the requirements that apply to licence-exempt radio apparatus.

## 3. TECHNICAL SUMMARY

### 3.1 SUMMARY OF STANDARDS AND TEST RESULTS

The EUT have been tested according to the applicable standards as referenced below:

Test Item	FCC	Result
-----------	-----	--------

6 dB bandwidth	§15.247 (a)	Pass
Power spectral density	§15.247 (e)	Pass
Peak Output Power (Conduction)	§15.247 (b)(1)	Pass
Spurious Emissions (Conduction)	§15.247 (d)	Pass
Band edge measurement	§15.247 (d)	Pass
Spurious Emissions (Radiation)	§15.247 (d) §15.35 (b) §15.209 (a)	Pass
Restricted Bands of operation	§15.205	Pass
AC power line conducted emissions	§15.207(a)	Pass

### 3.2 TEST UNCERTAINTY

Where relevant, the following test uncertainty levels have been estimated for tests performed on the EUT as specified in CISPR 16-4-2. This uncertainty represents an expanded uncertainty expressed at approximately the 95% confidence level using a coverage factor of k=2.

Test item	Value
Conducted disturbance	3.4 dB
Radiated disturbance	4.2 dB
Conducted output power	1.1 dB
Power spectral density	1.7 dB
Band width	20 kHz

### 3.3 TEST EQUIPMENT LIST

Equipment	Manufacturer	Model	Serial No.	Due Date
Receiver	Agilent	N9038A	MY51210142	11/01/2017
Power meter	R&S	NRP2	101607	06/07/2017
Loop Antenna	Schwarzbeck	FMZB1519	1519-020	03/24/2018
LISN	R&S	ENV216	100069	06/07/2017
3m Chamber & Accessory Equipment	ETS-LINDGREN	FACT-3	CT-0000336	03/12/2017
Microwave Preamplifier	EM Electronics	EM30180	3008A02425	06/07/2017
Power Splitter	Agilent	11667C/ 52401	MY53806148	02/26/2018
Biconilog Antenna	Schwarzbeck	VULB 9160	3316	09/08/2018
Horn Antenna	Schwarzbeck	BBHA9120D	942	09/08/2018
Horn Antenna	Schwarzbeck	BBHA9120D	943	09/08/2018
Horn Antenna(18-40GHz)	ETS	3116	00070497	09/08/2018
Directional coupler	ATM	C122H-10	C279710-02	/
RF cable	HUBER+SUHNER	SUCOFLEX 104	342800/4	/
Attenuator	Compliance Direction System	ATT-20	/	/
Wave Trap	Walwright instrument	WRCT2402/2480-2400/2483.5-30/20SS	SN30	/

### 3.4 TEST FACILITY

All test facilities used to collect the test data are located at No.1350, Lianxi Rd. Pudong New District, Shanghai, China. The site and apparatus are constructed in conformance with the requirements of ANSI C63.4: 2014, CISPR 16-1-1 and other equivalent standards. The laboratory is compliance with the requirements of the ISO/IEC/E 17025.



### **3.5 TEST SETUP CONFIGURATION**

The information contained within this report is intended to show verification of compliance of the EUT to the requirements of CFR 47 FCC Part 15.247.

Unilab has verified the construction and function in typical operation. All the test modes were carried out with the EUT in normal operation, which was shown in this test report.

## **4. 6 DB BANDWIDTH**

### **4.1 TEST SETUP**

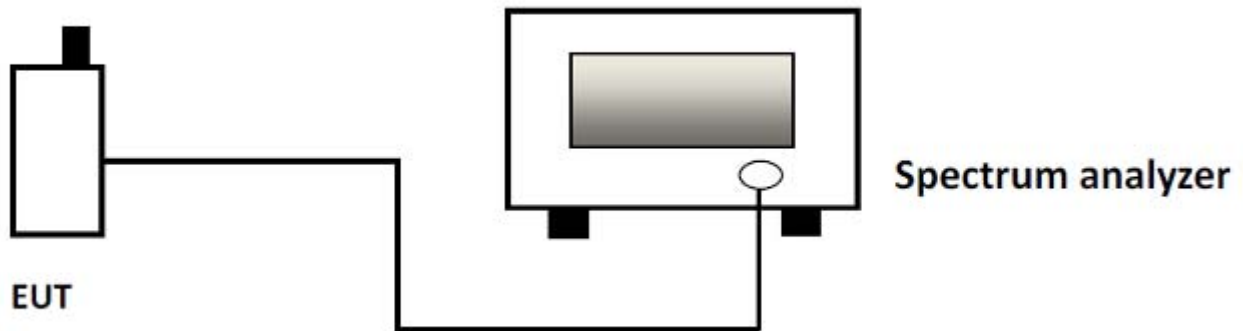

## 4.2 LIMITS

Limit	$\geq 500$ kHz
-------	----------------

## 4.3 TEST PROCEDURE

Place the EUT on the table and set it in transmitting mode. Remove the antenna from the EUT and then connect a low loss RF cable from the antenna port to spectrum analyzer. The loss between RF output port of the EUT and the input port of the tester will be taken into consideration.

The measurement will be conducted at three channels.

Bluetooth: Low (0), Middle (19) and High (39).

Using occupied BW measurement function of spectrum analyzer and settings are:

XdB = -6dB

RBW = 100 kHz

VBW  $\geq 3 \times$  RBW

Span = approximately 2 to 3 times the 6 dB bandwidth, centered on a channel

Sweep = auto

Detector function = peak

Trace = max hold

#### 4.4 RESULTS & PERFORMANCE

Channel	Measured 6dB bandwidth (KHz)	Limit (MHz)	Result
<b>Bluetooth V4.1 LE</b>			
GFSK CH0	679.6	≥0.5	PASS
GFSK CH19	667.2	≥0.5	PASS
GFSK CH39	682.4	≥0.5	PASS

#### Bluetooth V4.1 LE: GFSK channel 0

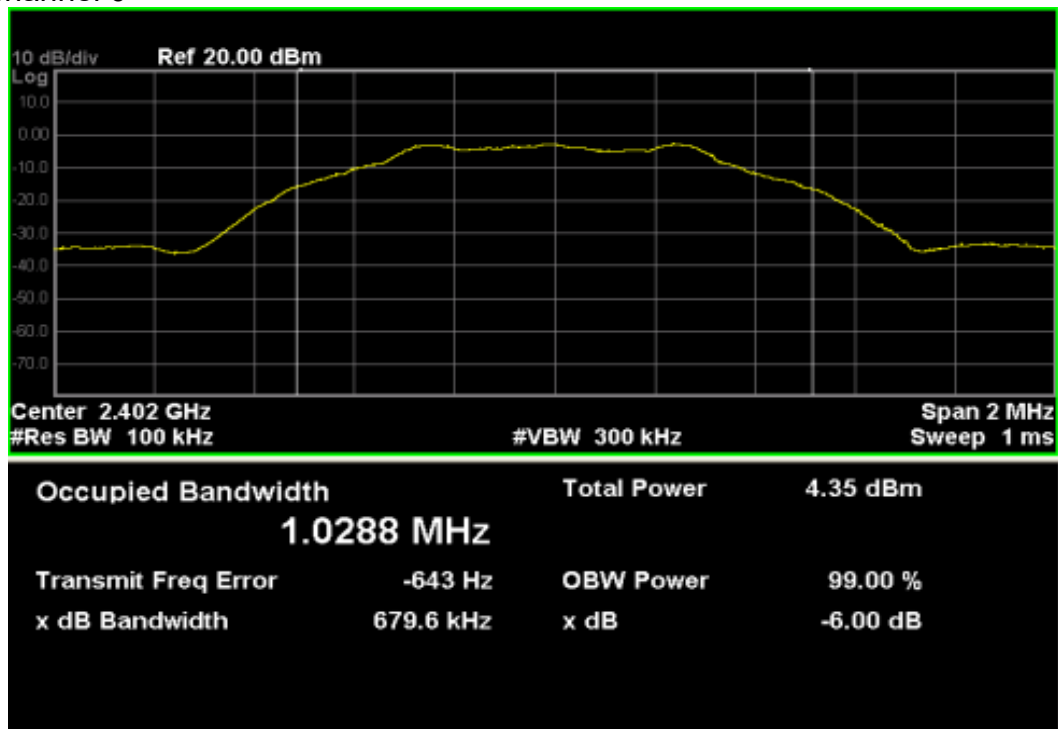

GFSK channel 19

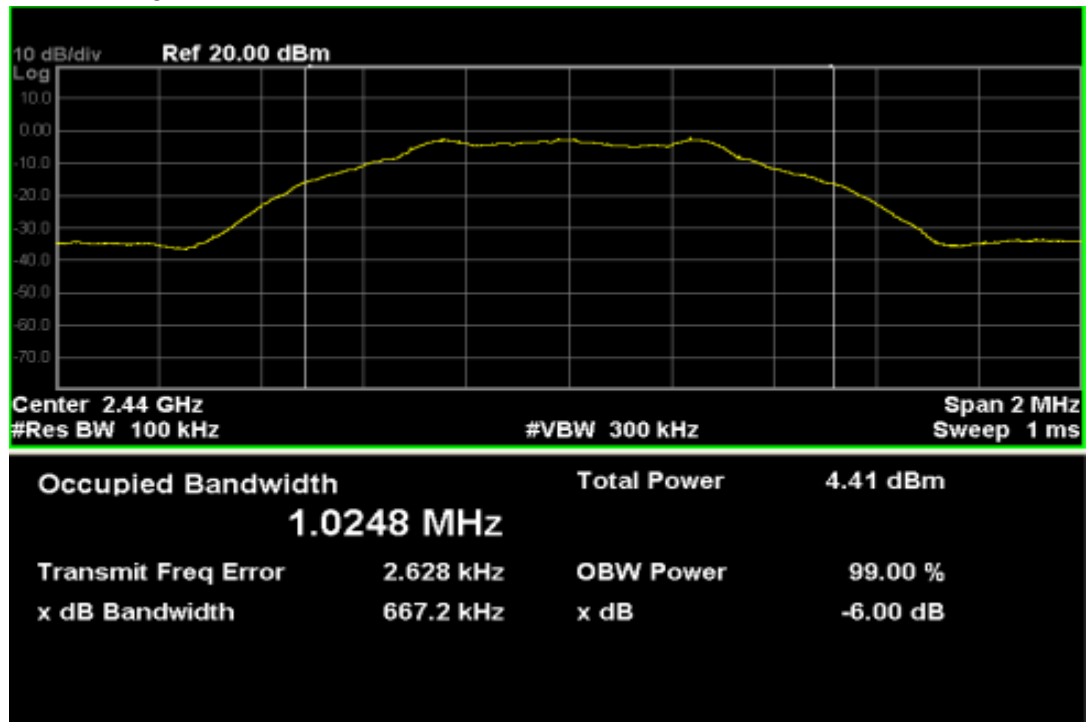

GFSK channel39

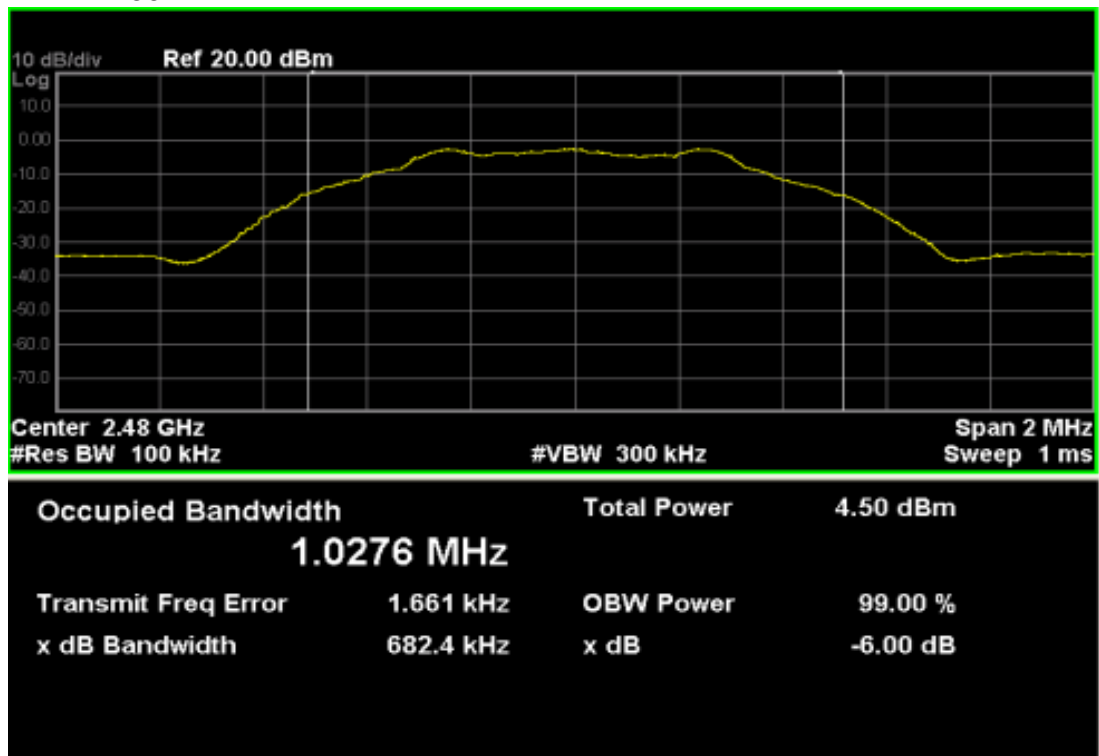

## 5. POWER SPECTRAL DENSITY

### 5.1 TEST SETUP

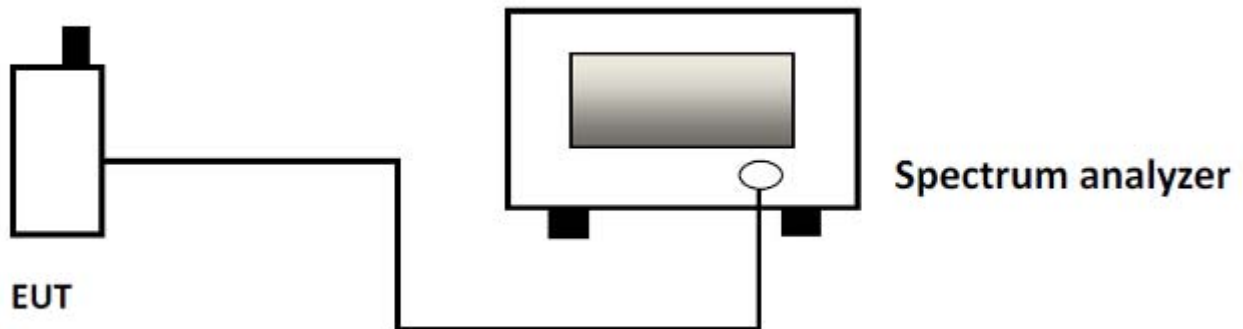

### 5.2 LIMITS

Limits	$\leq 8\text{dBm}/3\text{kHz}$
--------	--------------------------------

### 5.3 TEST PROCEDURE

Set analyzer center frequency to DTS channel center frequency.

Set the span to 1.5 times the DTS bandwidth.

Set the RBW to:  $3\text{ kHz} \leq \text{RBW} \leq 100\text{ kHz}$ .

Set the VBW  $\geq 3 \times \text{RBW}$ .

Detector = peak.

Sweep time = auto couple.

Trace mode = max hold.

Allow trace to fully stabilize.

Use the peak marker function to determine the maximum amplitude level within the RBW.

If measured value exceeds limit, reduce RBW (no less than 3 kHz) and repeat.

### 5.4 RESULTS & PERFORMANCE

Mode	Channel	Measured level (dBm/3KHz)	Limit (dBm/3KHz)	Result
Bluetooth V4.1 LE	CH0	-16.996	≤8.00	Pass
	CH19	-16.841	≤8.00	Pass
	CH39	-16.720	≤8.00	Pass

#### Bluetooth V4.1 LE GFSK Channel 0

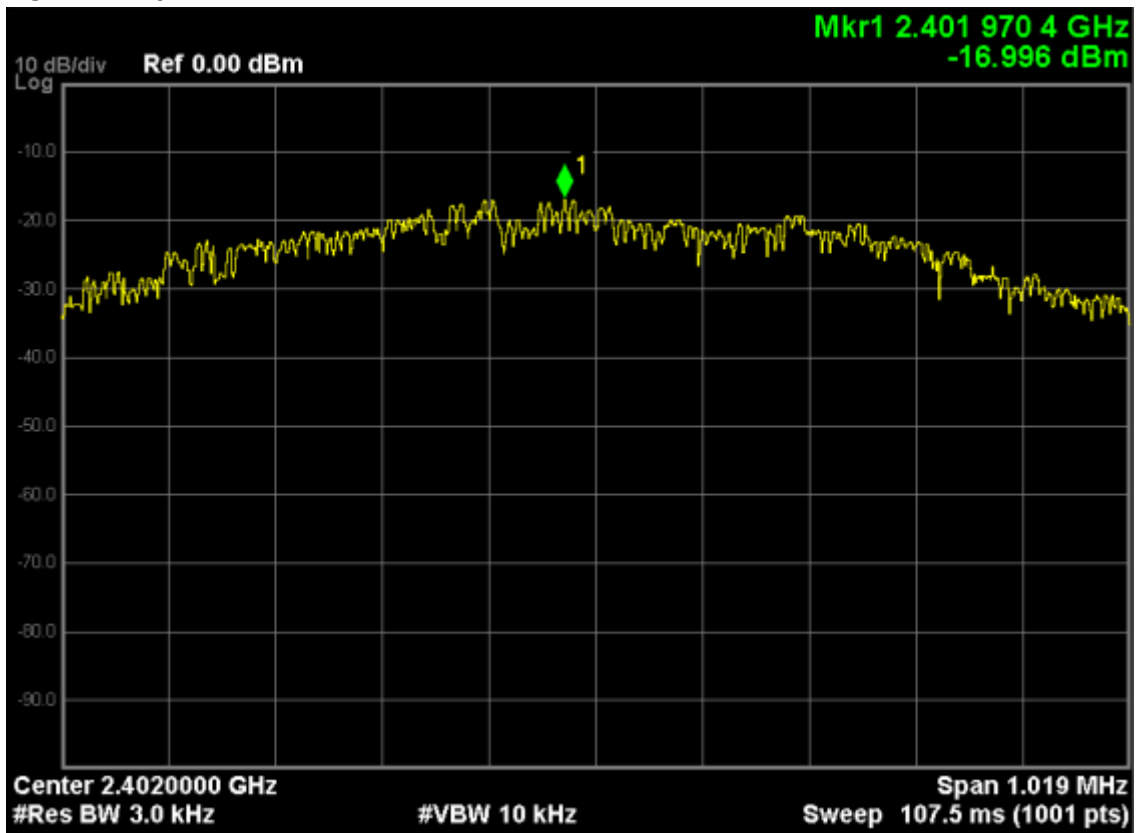

GFSK Channel 19

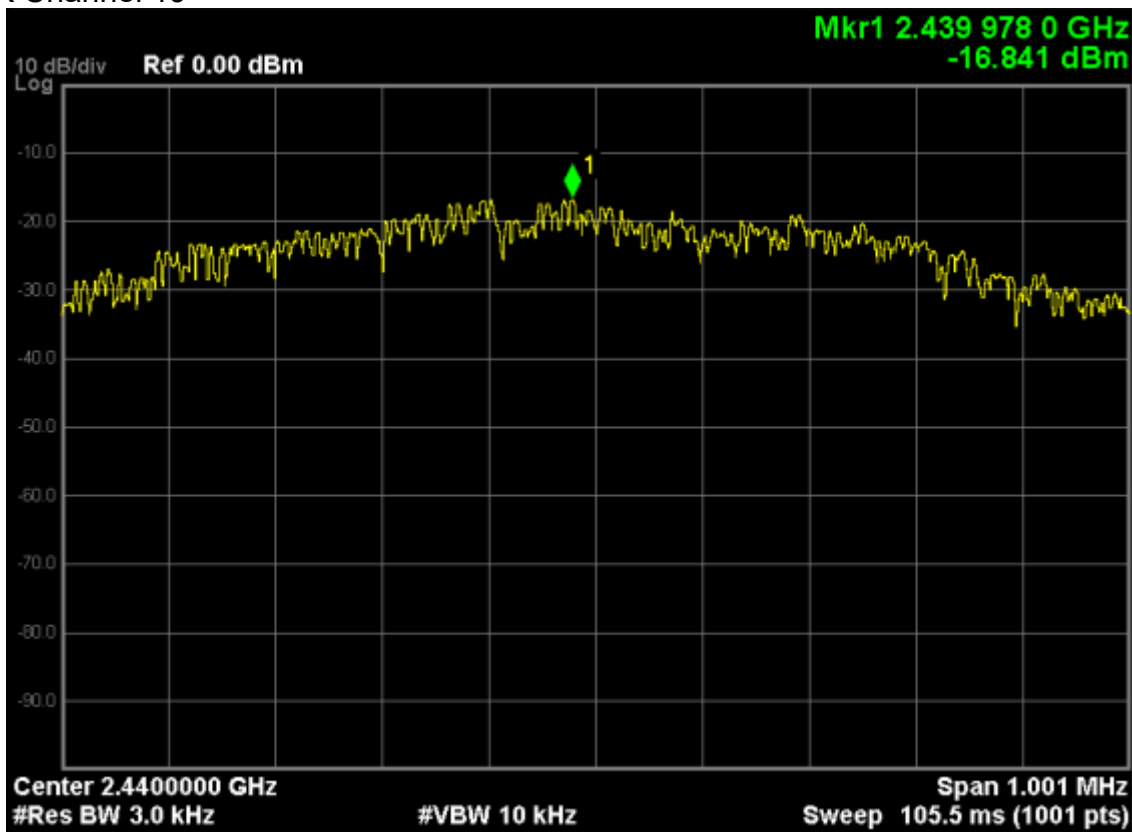

GFSK Channel 39

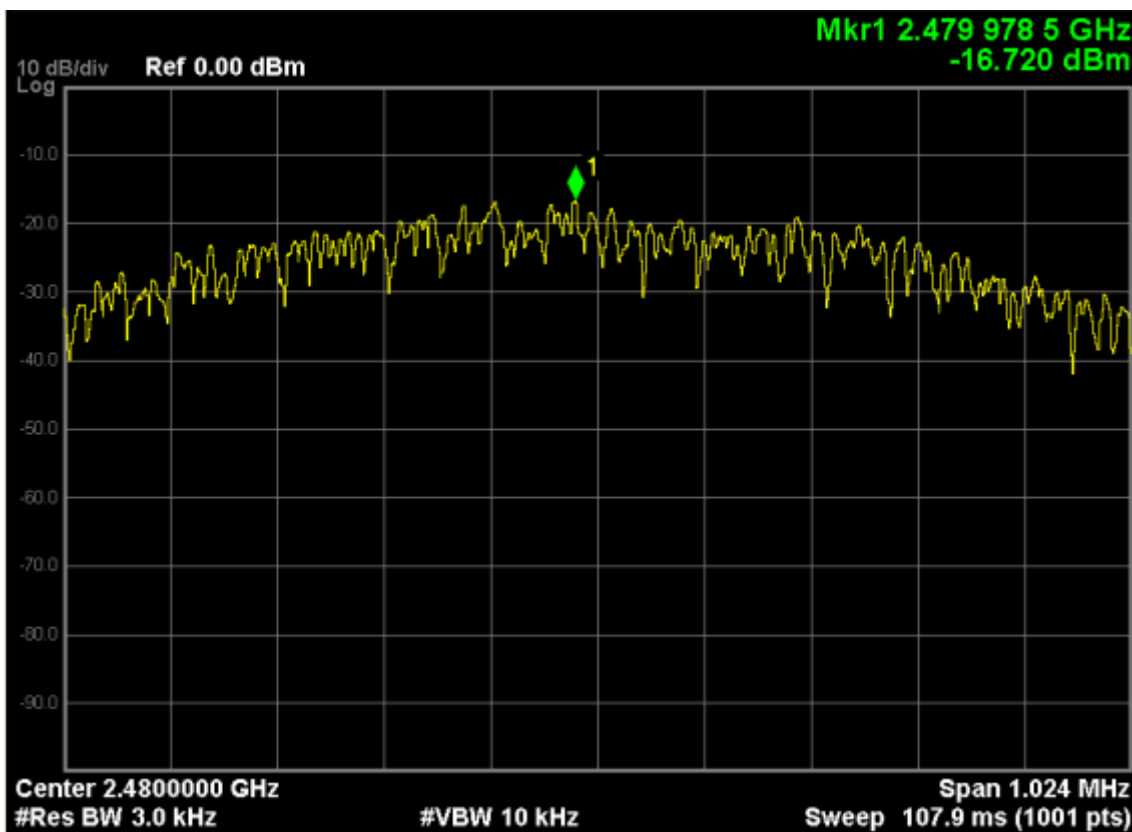

## 6. PEAK OUTPUT POWER (CONDUCTION)

### 6.1 TEST SETUP

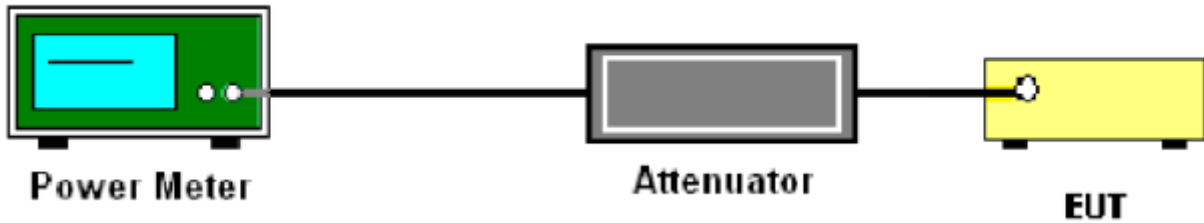

### 6.2 LIMITS

Limits	<30dBm
--------	--------

### 6.3 TEST PROCEDURE

Place the EUT on the table and set it in transmitting mode. Remove the antenna from the EUT and then connect a low loss RF cable from the antenna port to spectrum analyzer. The loss between RF output port of the EUT and the input port of the tester will be taken into consideration.

The measurement will be conducted at three channels.  
 Bluetooth: Low(0), Middle(19) and High (39).

### 6.4 RESULTS & PERFORMANCE

Bluetooth V4.1 LE			
Channel	Peak power (dBm)	Limit (dBm)	Margin (dB)
0 (2402MHz)	1.4	30	28.6
19 (2440MHz)	1.5	30	28.5
39 (2480MHz)	1.2	30	28.8



## 7. SPURIOUS EMISSIONS (CONDUCTION)

### 7.1 TEST SETUP

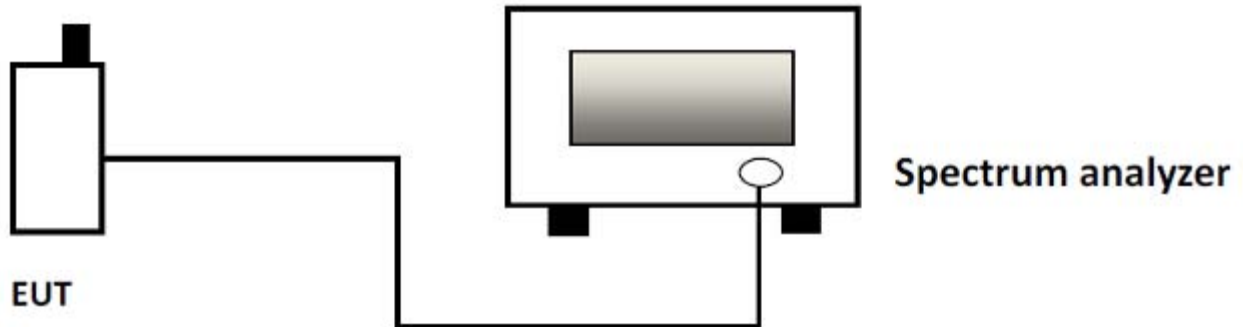

### 7.2 LIMITS

Limit	<(P-20dB)
Note: P is the highest level of the desired power	

### 7.3 TEST PROCEDURE

The EUT was connected to Spectrum Analyzer and Base Station via power divider. Use the following spectrum analyzer settings:

Span = wide enough to capture the peak level of the in-band emission and all spurious emissions (e.g., harmonics) from the lowest frequency generated in the EUT up through the 10th harmonic. Typically, several plots are required to cover this entire span.

RBW = 100 kHz; VBW ≥ RBW; Sweep = auto; Detector function = peak; Trace = max hold  
Allow the trace to stabilize. Set the marker on the peak of any spurious emission recorded.

The level displayed must comply with the limit specified in this Section.

### 7.4 RESULTS & PERFORMANCE

#### Bluetooth V4.1 LE GFSK Channel 0

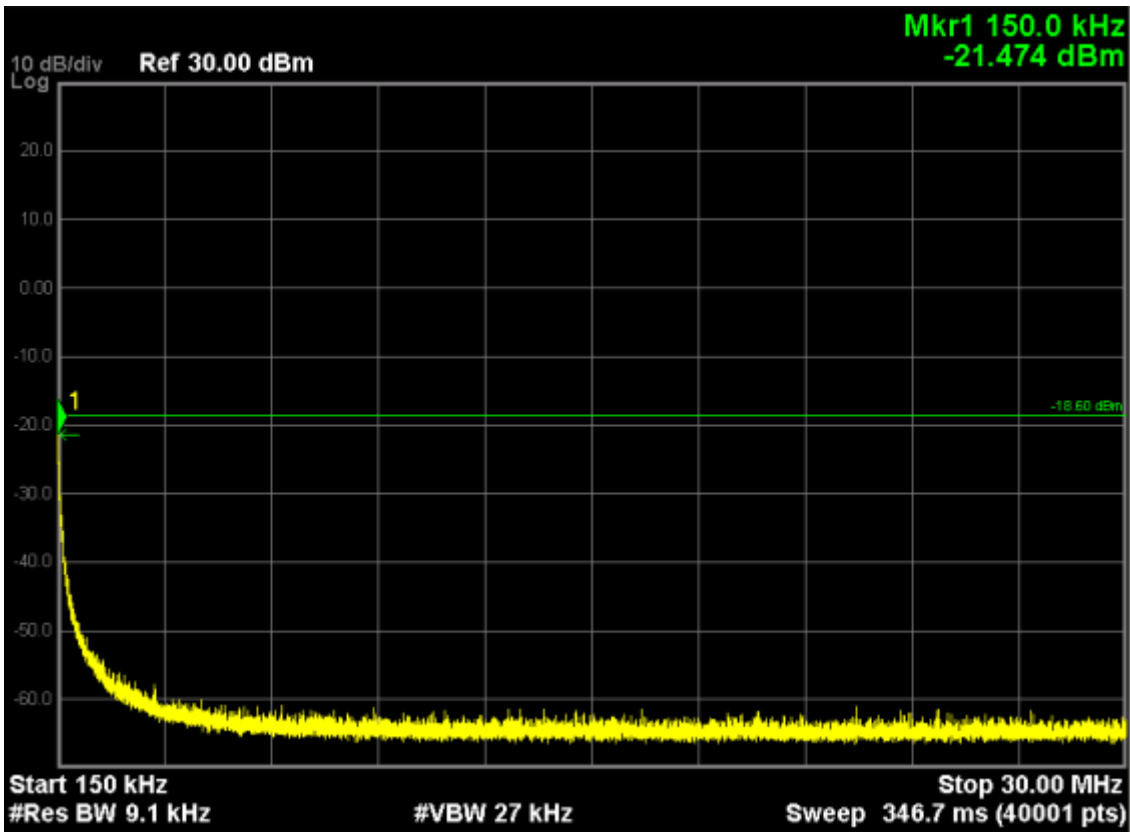
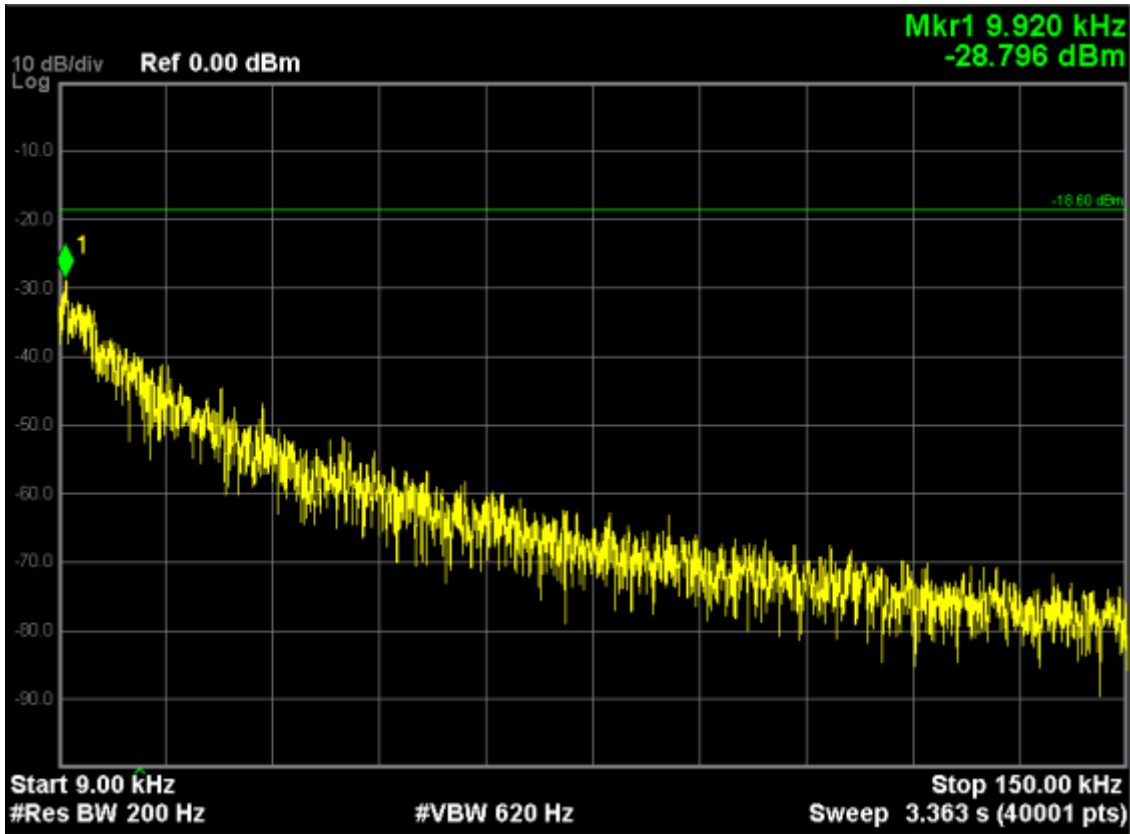

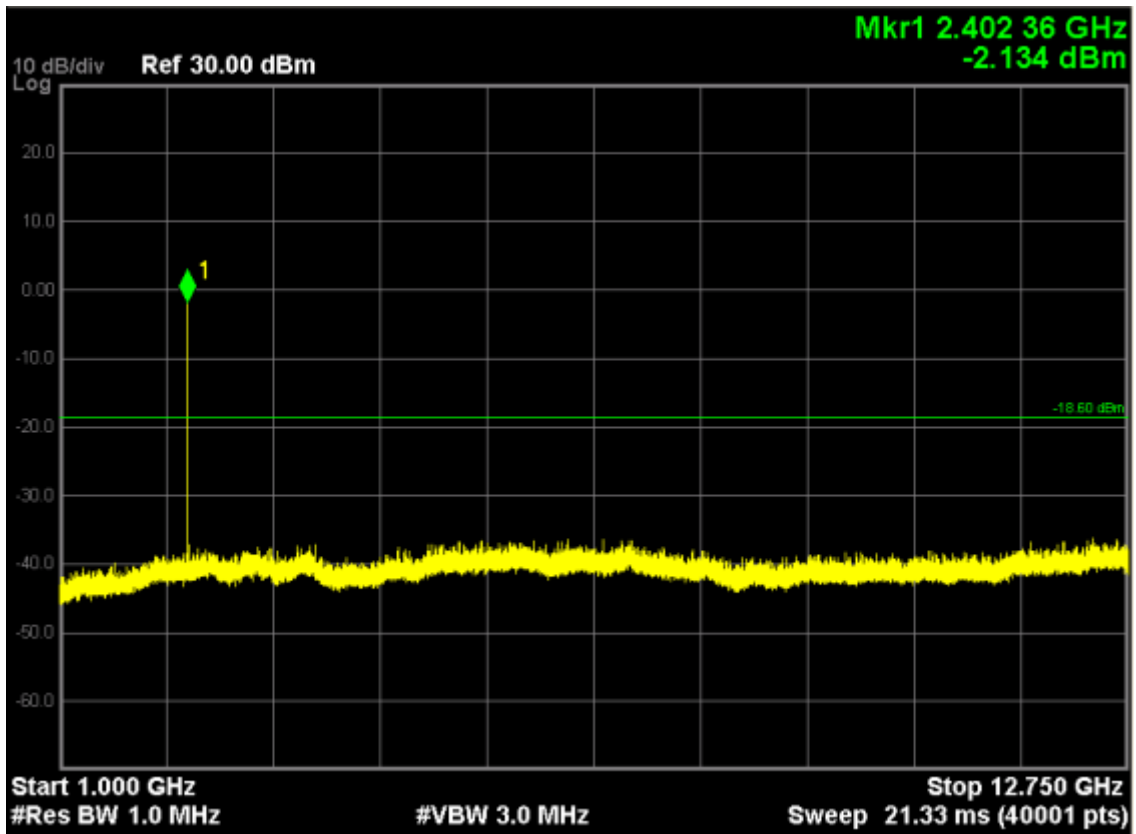
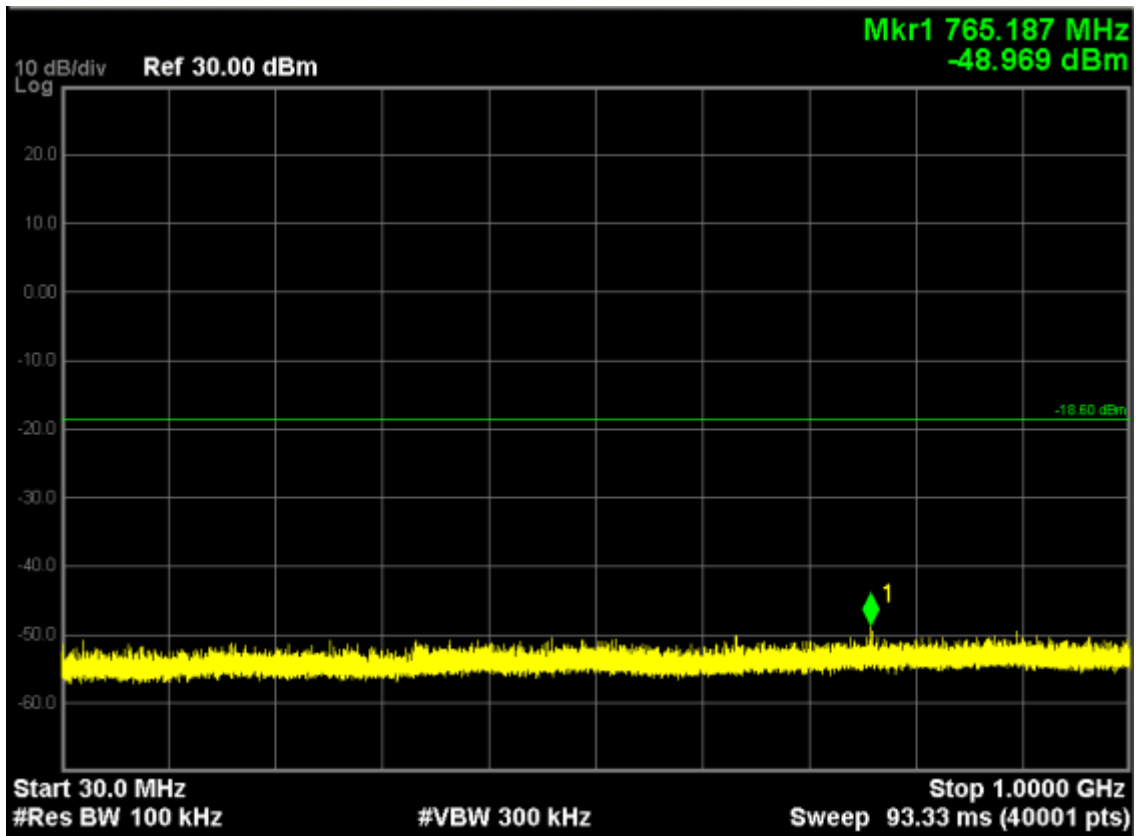

Note: The point mark1 is carrier.

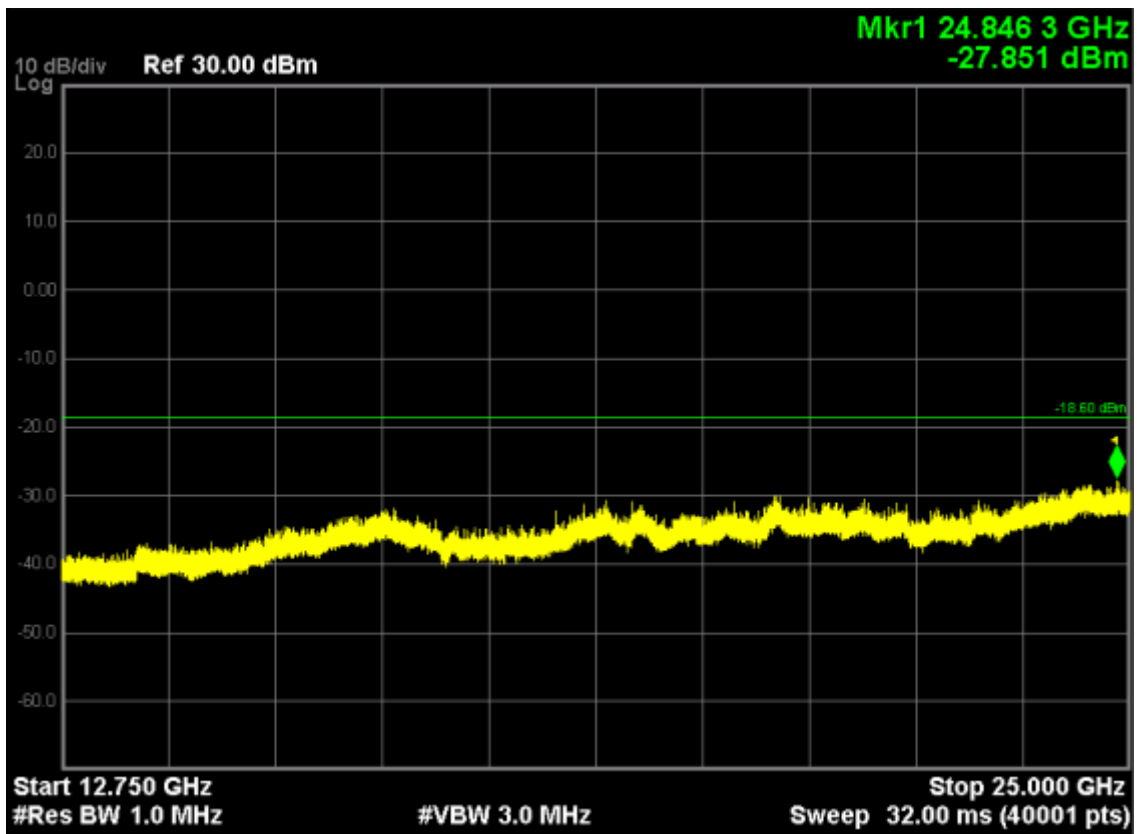

### Bluetooth V4.1 LE GFSK Channel 19

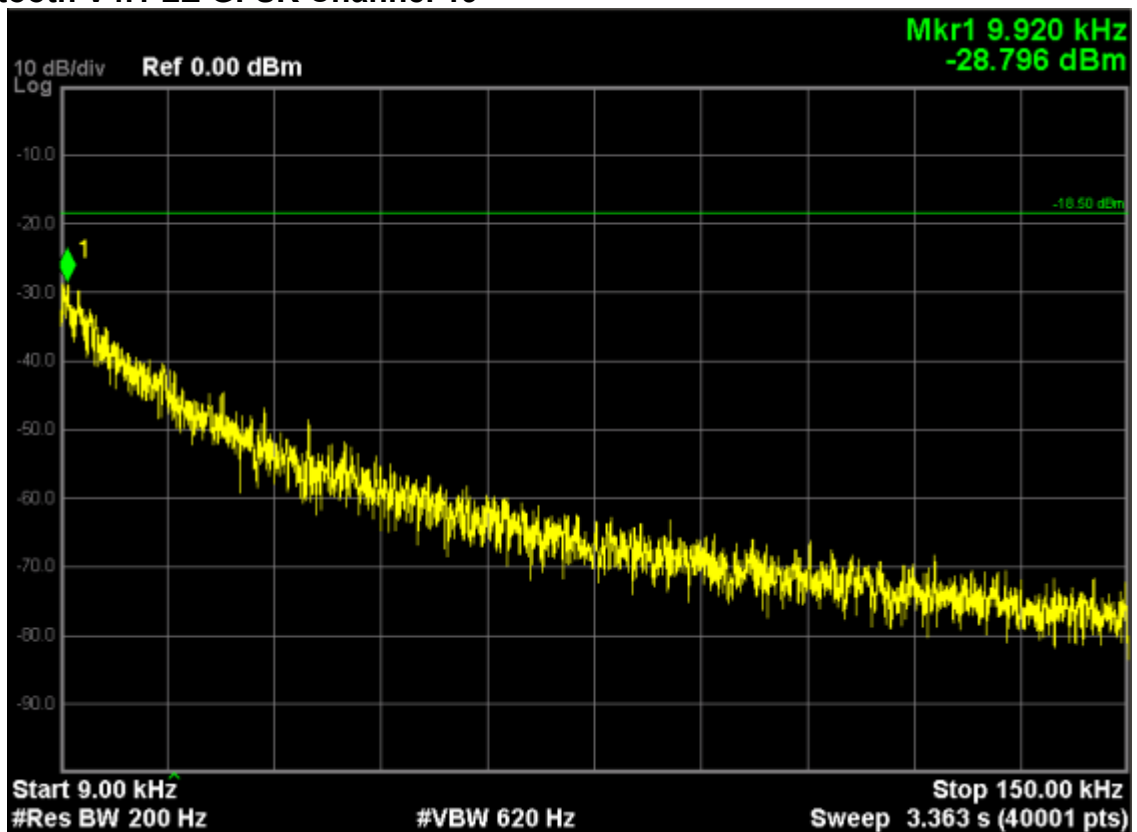

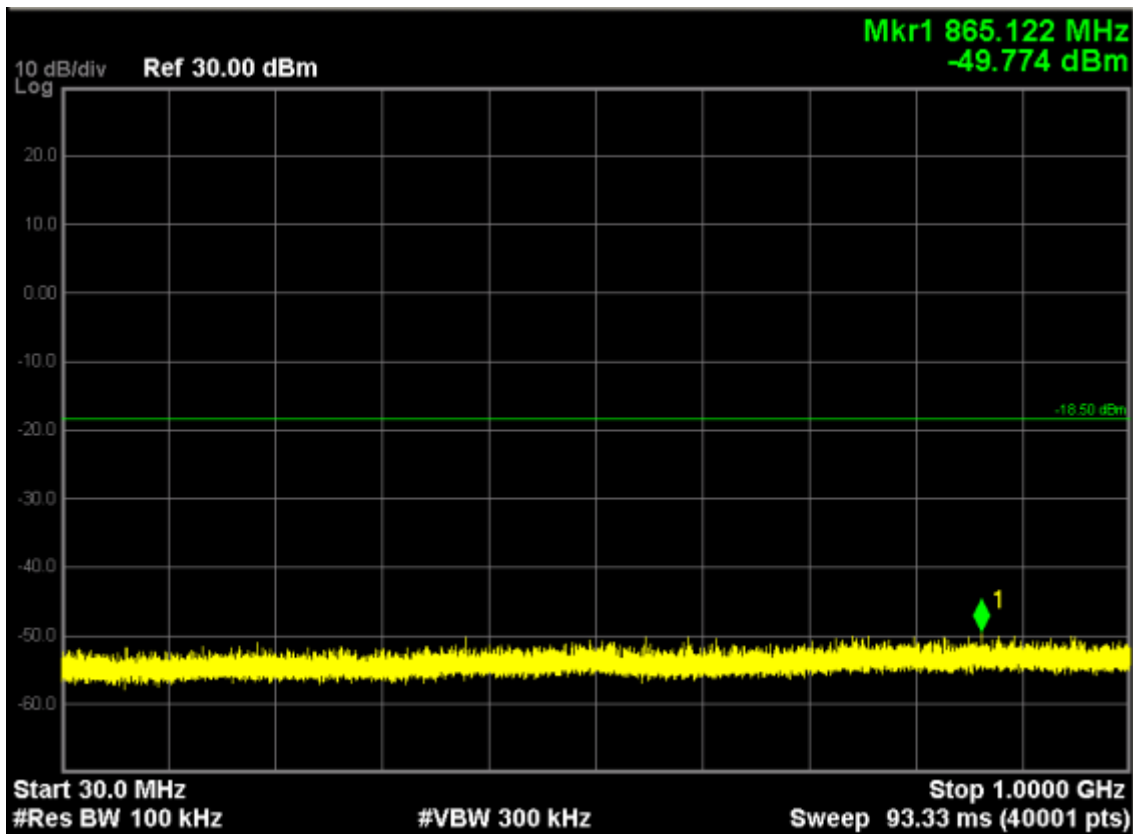
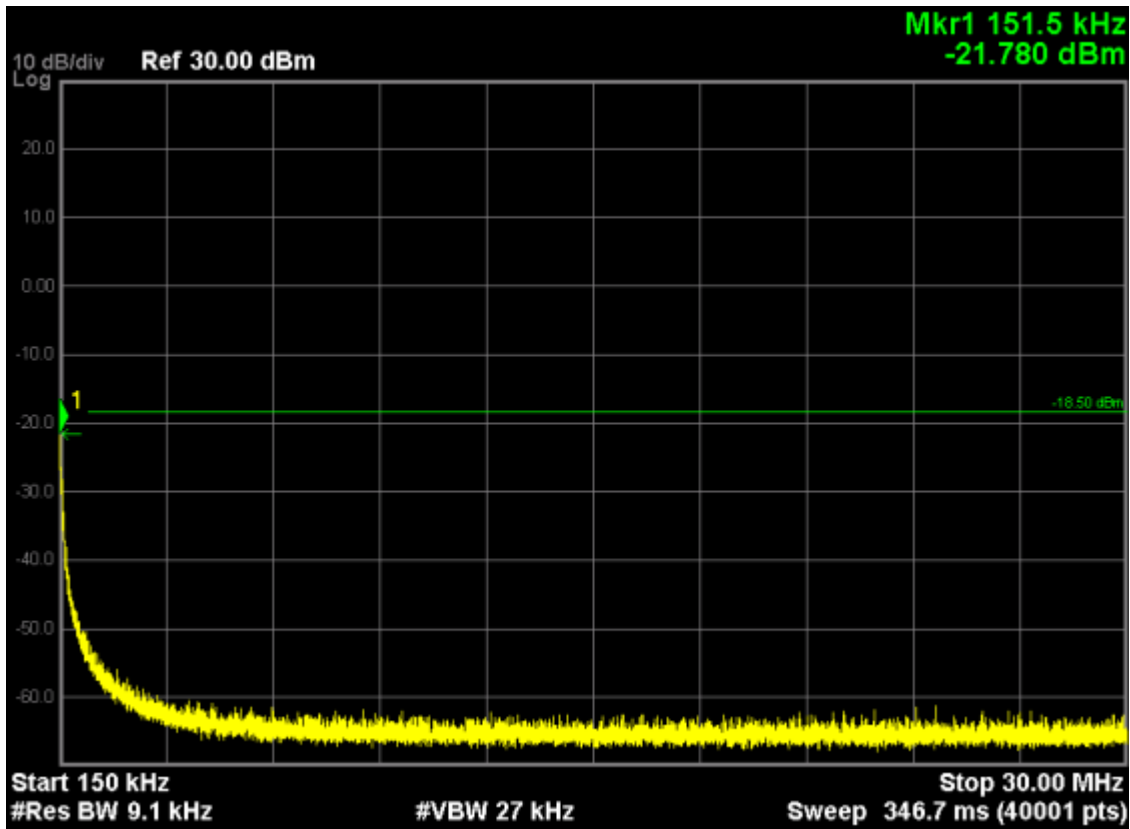

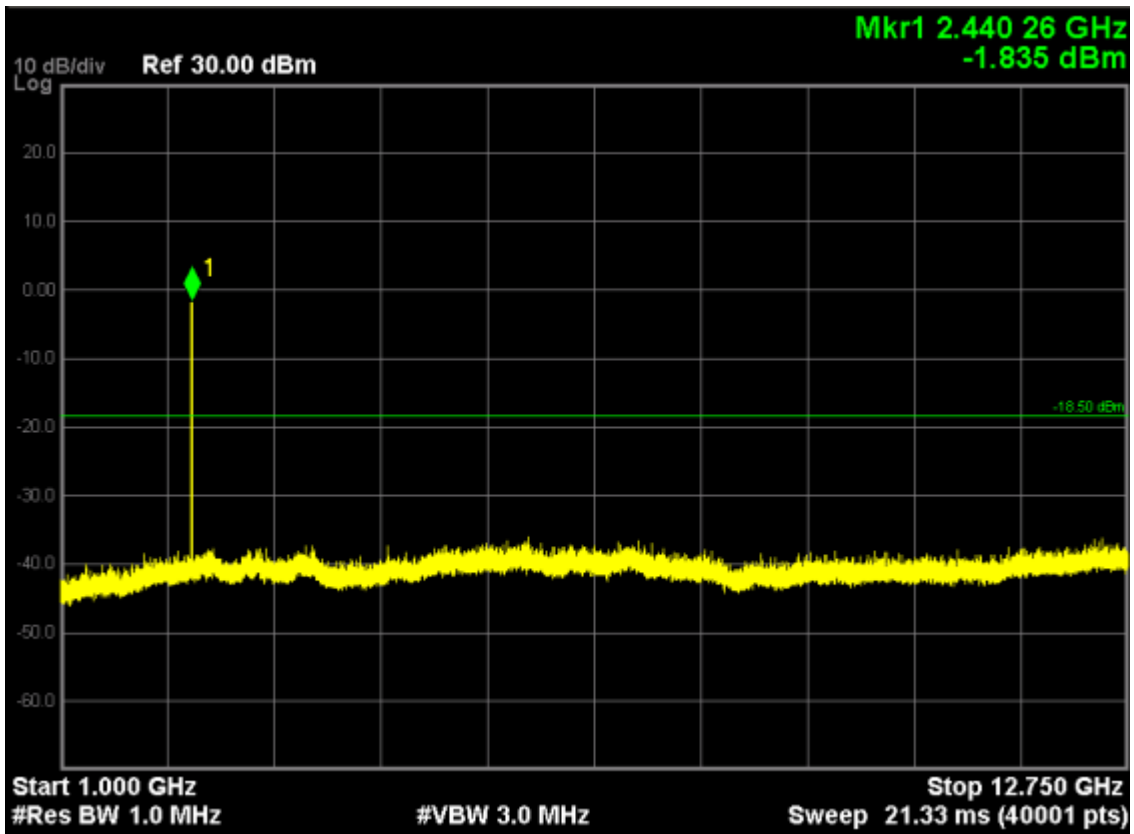

Note: The Mark1 point is carrier.

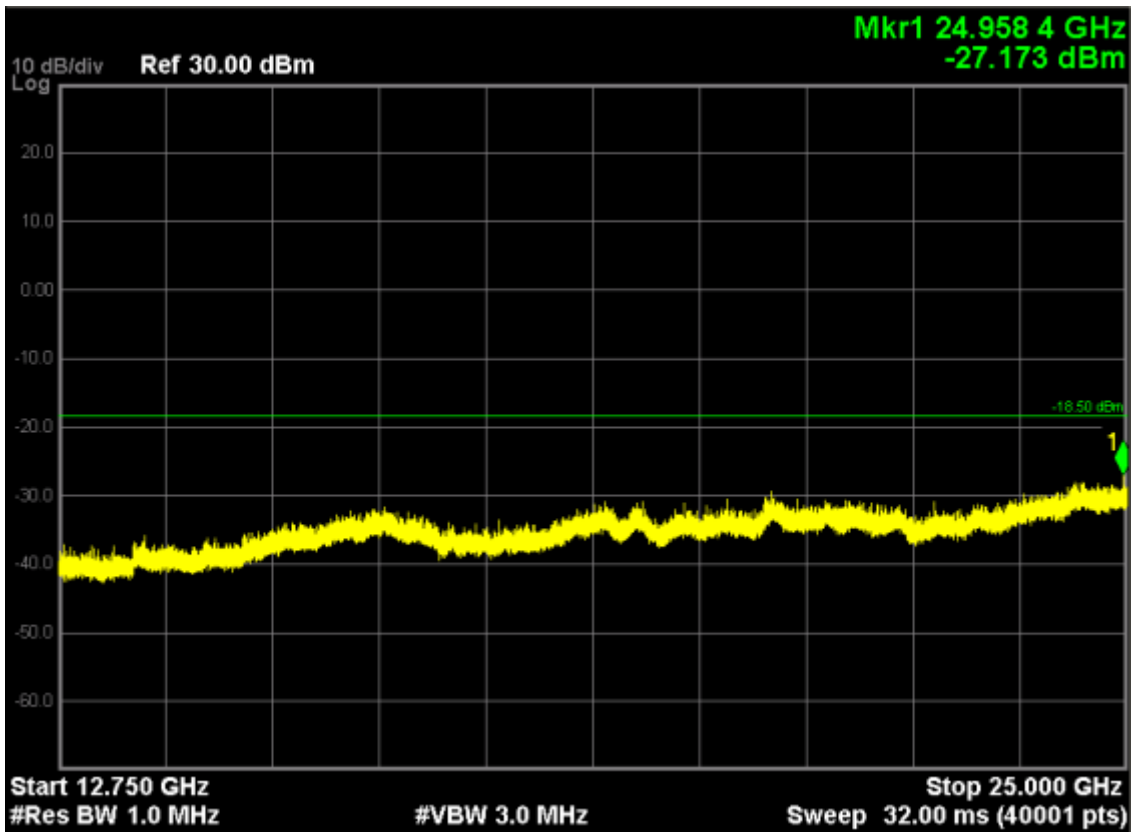

### Bluetooth V4.1 LE GFSK Channel 39

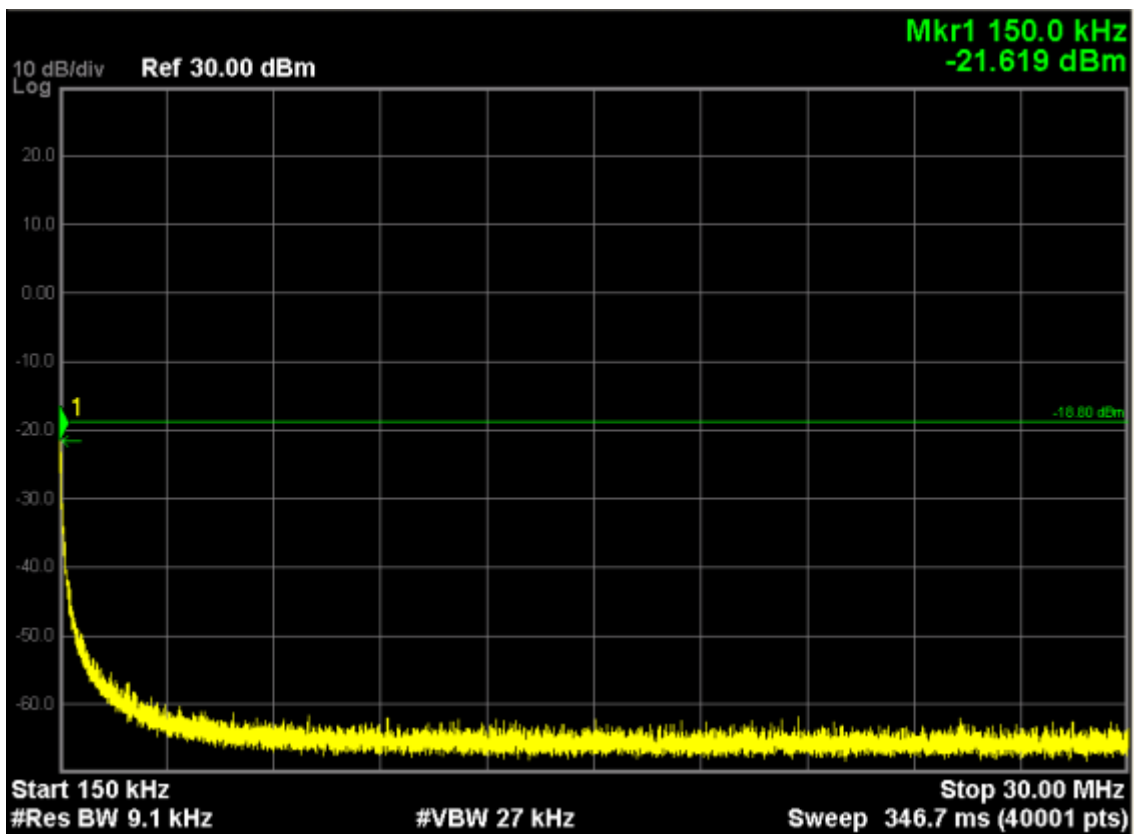
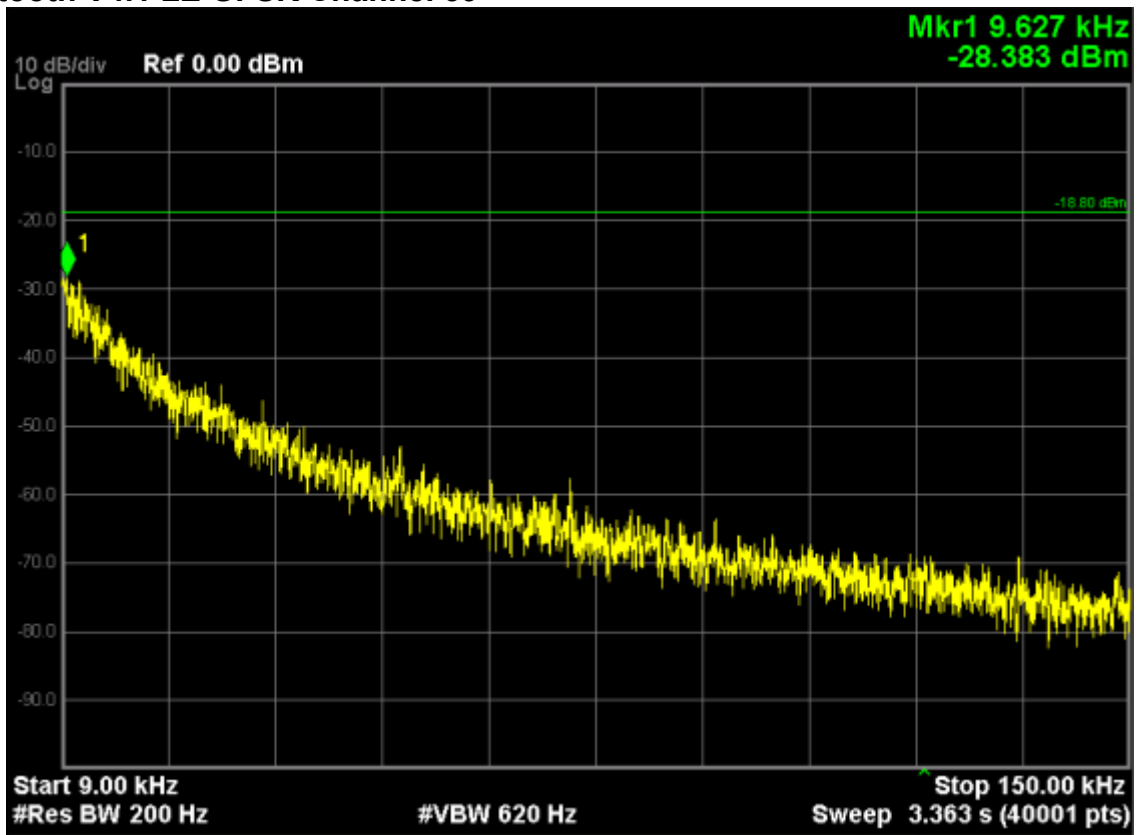

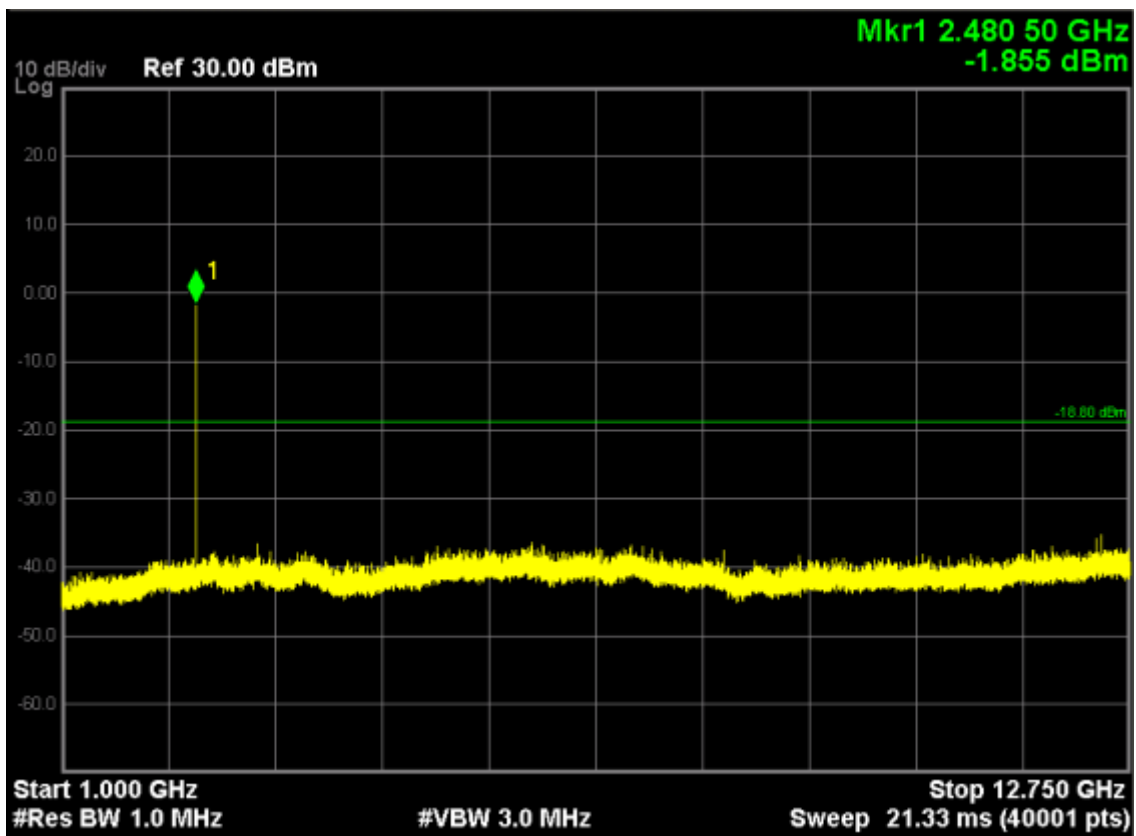
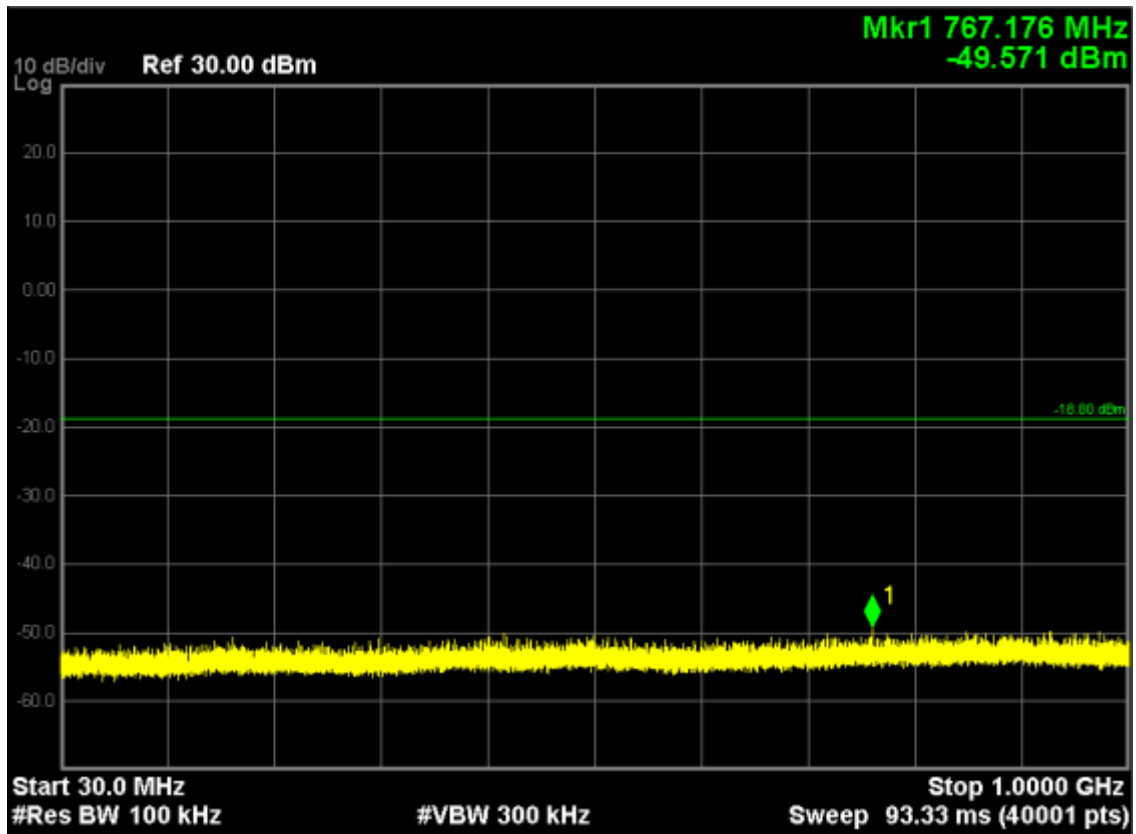

Note: The Mark1 point is carrier.



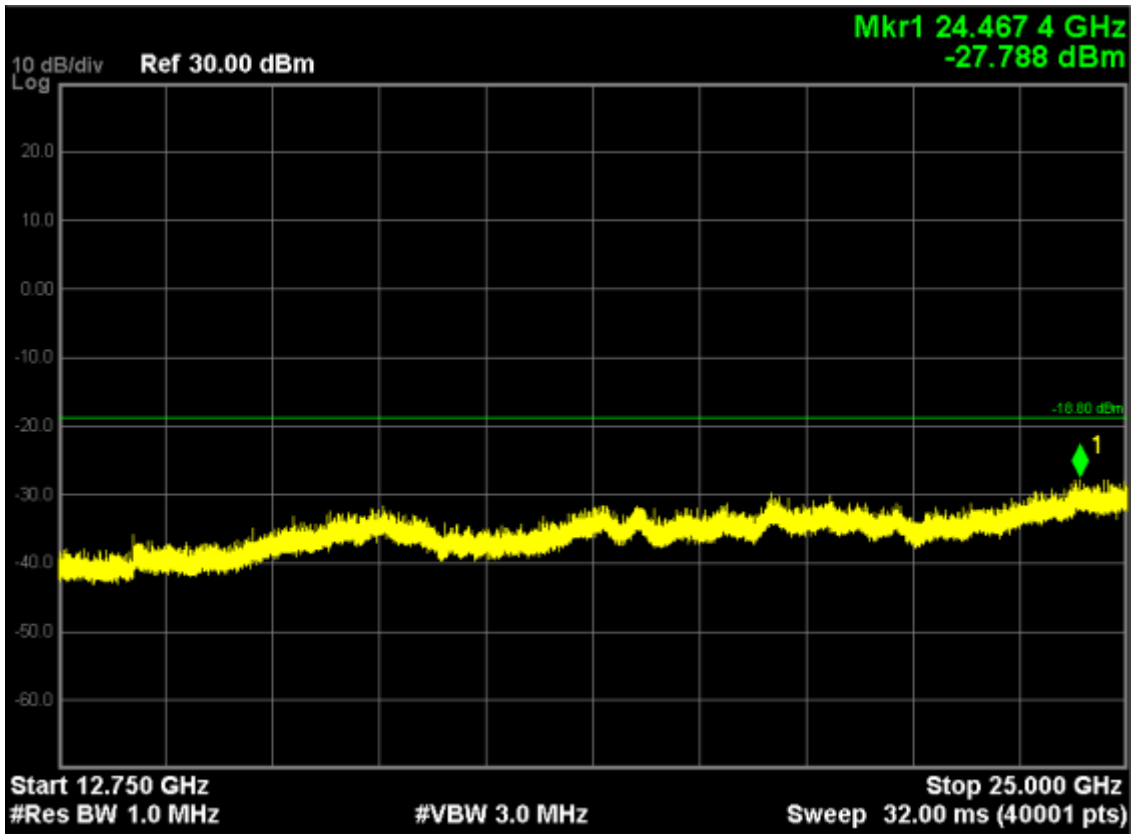

## 8. BAND EDGE MEASUREMENT

### 8.1 TEST SETUP

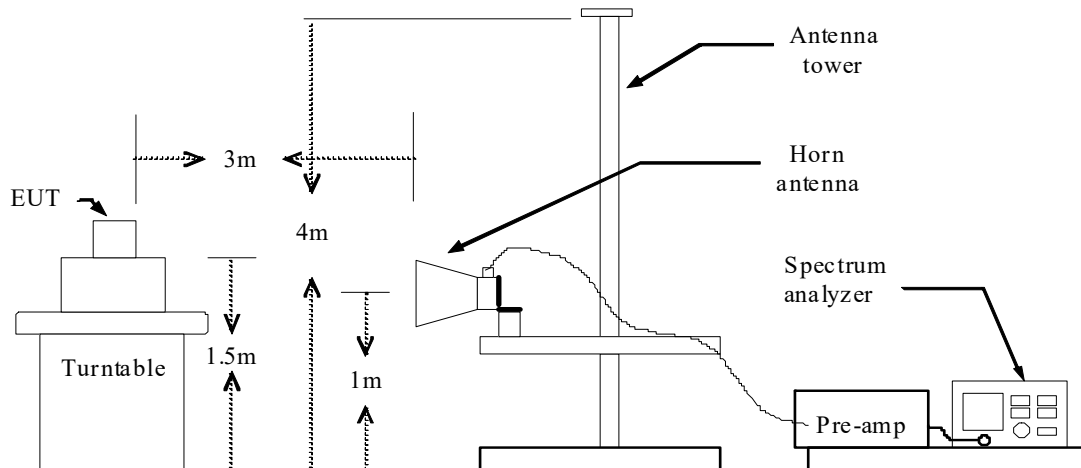

### 8.2 LIMITS

According to §15.247(d), in any 100 kHz bandwidth outside the frequency bands in which the spread spectrum intentional radiator is operating, the radio frequency power that is produced by the intentional radiator shall be at least 20dB below that in the 100kHz bandwidth within the band that contains the highest level of the desired power. In addition, radiated emissions which fall in the restricted bands, as defined in §15.205(a), must also comply with the radiated emission limits specified in 15.209(a).

### 8.3 TEST PROCEDURE

The EUT is placed on a turntable, which is 0.8m above the ground plane.

The turntable shall be rotated for 360 degrees to determine the position of maximum emission level.

EUT is set 3m away from the receiving antenna, which is varied from 1m to 4m to find out the highest emission.

Set the spectrum analyzer in the following setting in order to capture the lower and upper band-edges of the emission:

PEAK: RBW=VBW=1MHz / Sweep=AUTO

AVERAGE: RBW=1MHz / VBW=10Hz / Sweep=AUTO

Repeat the procedures until all the PEAK and AVERAGE versus POLARIZATION are measured.

### 8.4 RESULTS & PERFORMANCE

**Radiated Band Edge:**

**Bluetooth V4.1 LE GFSK Channel 0**

**Test mode : Mode 1**

Detector mode: Peak

Polarity: Horizontal

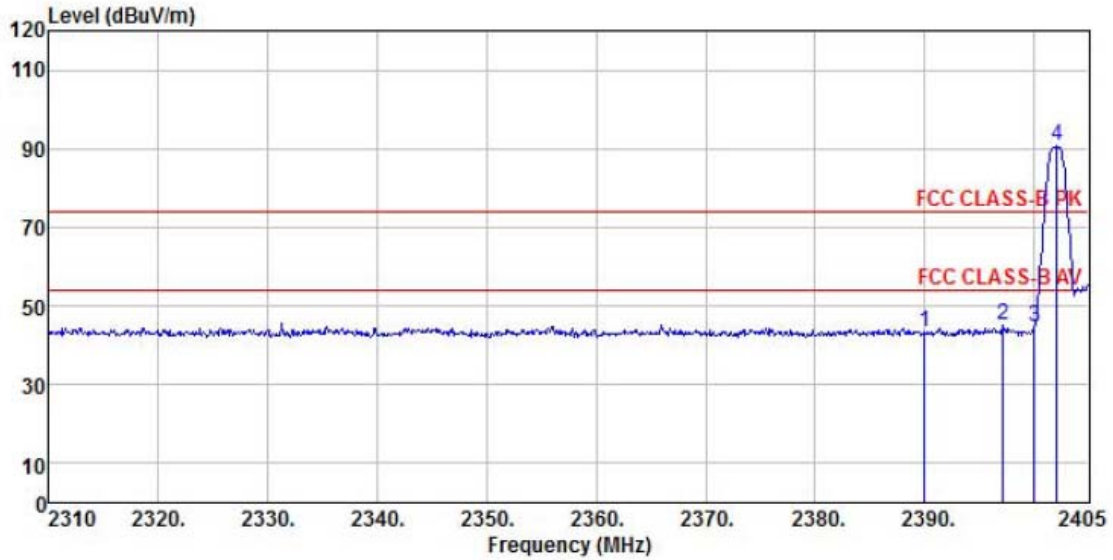

Site : chamber  
 Condition : FCC CLASS-B PK 3m BBHA9120D(942) HORIZONTAL  
 EUT :  
 Model Name : F800  
 Temp/Humi : 18 °C / 48 %  
 Power Rating:  
 Mode : BT CH0  
 Memo :

	Read	Antenna	Cable	Preamp	Limit	Over	
	Freq	Level	Factor	Loss	Factor	Level	Line
	MHz	dBuV	dB/m	dB	dB	dBuV/m	dBuV/m
1	2389.99	47.24	27.58	7.13	38.34	43.61	74.00 -30.39 Peak
2	2397.21	48.83	27.58	7.13	38.34	45.20	74.00 -28.80 Peak
3	2400.06	48.43	27.58	7.13	38.34	44.80	74.00 -29.20 Peak
4 pp	2402.15	94.35	27.54	7.13	38.34	90.68	74.00 16.68 Peak

Detector mode: Average

Polarity: Horizontal

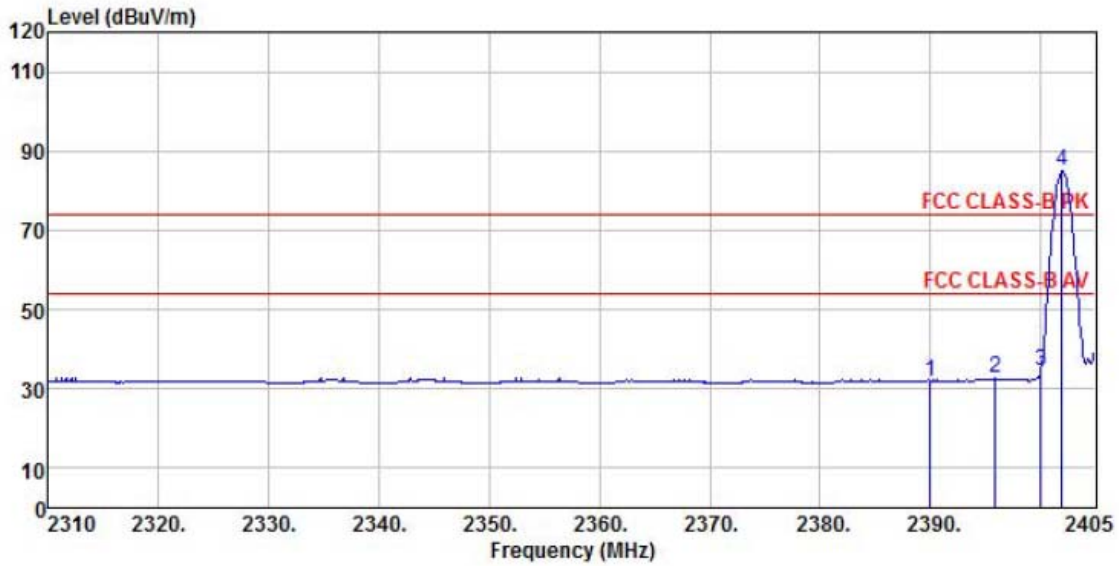

Site : chamber  
 Condition : FCC CLASS-B PK 3m BBHA9120D(942) HORIZONTAL  
 EUT :  
 Model Name : F800  
 Temp/Humi : 18 °C / 48 %  
 Power Rating:  
 Mode : BT CHO  
 Memo :

ReadAntenna Cable Preamp Limit Over  
 Freq Level Factor Loss Factor Level Line Limit Remark

	MHz	dBuV	dB/m	dB	dB	dBuV/m	dBuV/m	dB	
1	2389.99	35.41	27.58	7.13	38.34	31.78	54.00	-22.22	Average
2	2395.88	36.61	27.58	7.13	38.34	32.98	54.00	-21.02	Average
3	2400.06	38.27	27.58	7.13	38.34	34.64	54.00	-19.36	Average
4 pp	2401.96	88.59	27.54	7.13	38.34	84.92	54.00	30.92	Average

Detector mode: Peak

Polarity: Vertical

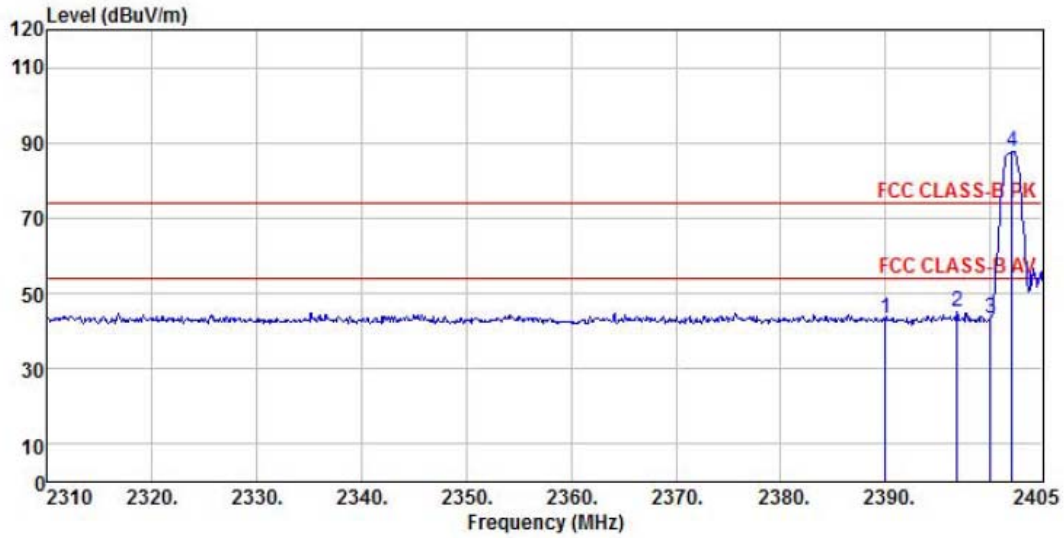

Site : chamber  
 Condition : FCC CLASS-B PK 3m BBHA9120D(942) VERTICAL  
 EUT :  
 Model Name : F800  
 Temp/Humi : 18 °C / 48 %  
 Power Rating:  
 Mode : BT CHO  
 Memo :

	Read	Antenna	Cable	Preamp	Limit	Over	
Freq	Level	Factor	Loss	Factor	Level	Line	Limit
MHz	dBuV	dB/m	dB	dB	dBuV/m	dBuV/m	dB
1	2389.99	46.95	27.58	7.13	38.34	43.32	74.00 -30.68 Peak
2	2396.83	48.93	27.58	7.13	38.34	45.30	74.00 -28.70 Peak
3	2400.06	47.15	27.58	7.13	38.34	43.52	74.00 -30.48 Peak
4 pp	2402.15	91.33	27.54	7.13	38.34	87.66	74.00 13.66 Peak

Detector mode: Average

Polarity: Vertical

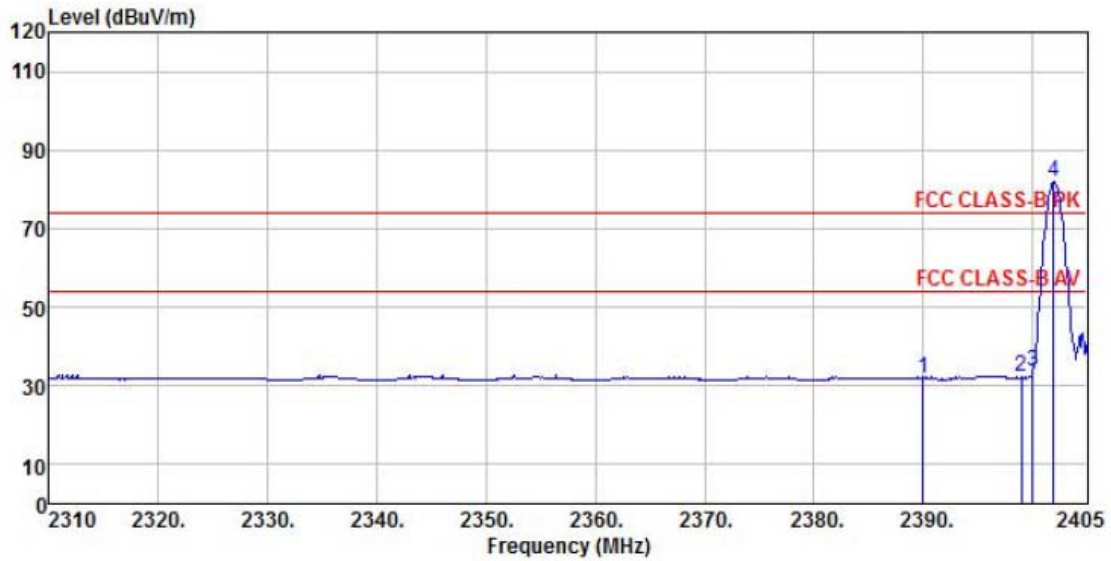

Site : chamber  
 Condition : FCC CLASS-B PK 3m BBHA9120D(942) VERTICAL  
 EUT :  
 Model Name : F800  
 Temp/Humi : 18 °C / 48 %  
 Power Rating:  
 Mode : BT CH0  
 Memo :

	Read	Antenna	Cable	Preamp	Limit	Over		
	Freq	Level	Factor	Loss	Factor	Level	Line	Limit
	MHz	dBuV	dB/m	dB	dB	dBuV/m	dBuV/m	dB
1	2389.99	35.37	27.58	7.13	38.34	31.74	54.00	-22.26
2	2399.02	36.08	27.58	7.13	38.34	32.45	54.00	-21.55
3	2400.06	37.10	27.58	7.13	38.34	33.47	54.00	-20.53
4 pp	2401.96	85.73	27.54	7.13	38.34	82.06	54.00	28.06

**Bluetooth V4.1 LE GFSK Channel 39**

Detector mode: Peak

Polarity: Horizontal

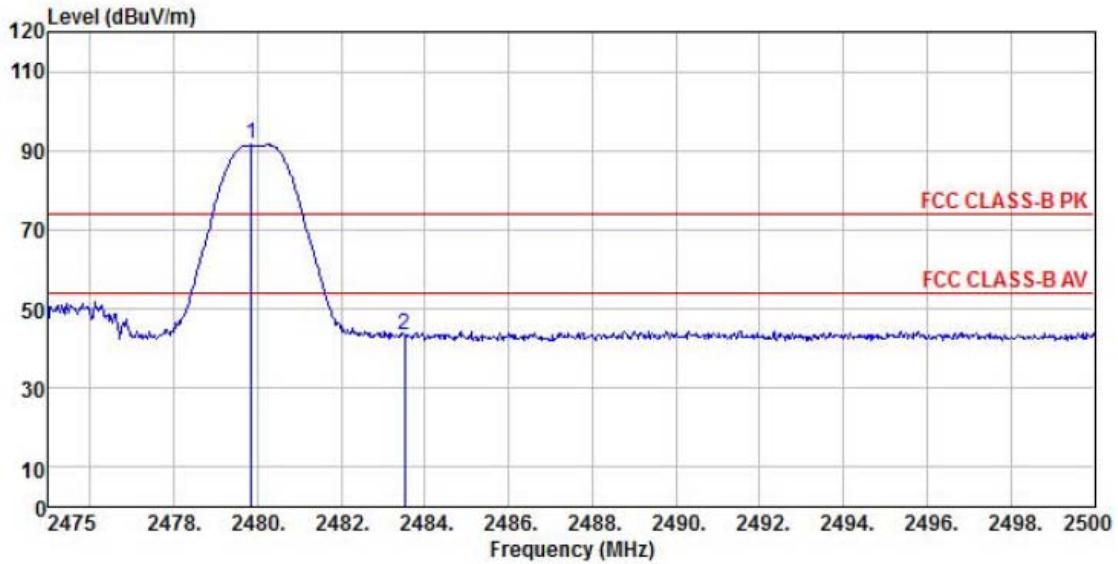

Site : chamber  
 Condition : FCC CLASS-B PK 3m BBHA9120D(942) HORIZONTAL  
 EUT :  
 Model Name : F800  
 Temp/Humi : 18 °C / 48 %  
 Power Rating:  
 Mode : BT CH39  
 Memo :

	Read	Antenna	Cable	Preamp	Limit	Over	
Freq	Level	Factor	Loss	Factor	Level	Line	Limit
MHz	dBuV	dB/m	dB	dB	dBuV/m	dBuV/m	dB

1	pp	2479.85	94.94	27.52	7.41	38.31	91.56	74.00	17.56	Peak
2		2483.50	46.62	27.52	7.41	38.31	43.24	74.00	-30.76	Peak

Detector mode: Average

Polarity: Horizontal

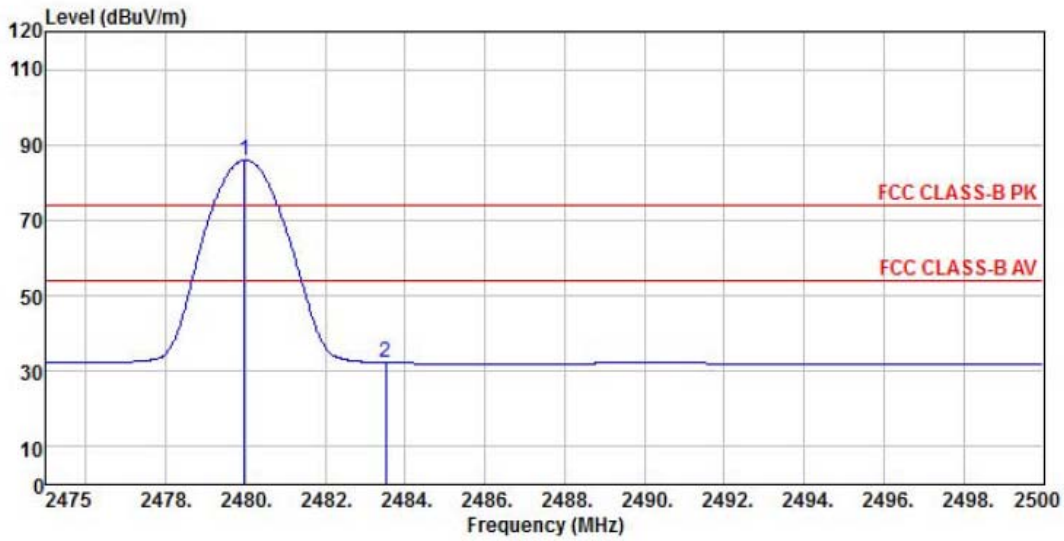

Site : chamber  
 Condition : FCC CLASS-B PK 3m BBHA9120D(942) HORIZONTAL  
 EUT :  
 Model Name : F800  
 Temp/Humi : 18 °C / 48 %  
 Power Rating:  
 Mode : BT CH39  
 Memo :

ReadAntenna Cable Preamp Limit Over  
 Freq Level Factor Loss Factor Level Line Limit Remark

	MHz	dBuV	dB/m	dB	dB	dBuV/m	dBuV/m	dB
1	pp 2479.98	89.31	27.52	7.41	38.31	85.93	54.00	31.93 Average
2	2483.50	35.66	27.52	7.41	38.31	32.28	54.00	-21.72 Average



Detector mode: Peak

Polarity: Vertical

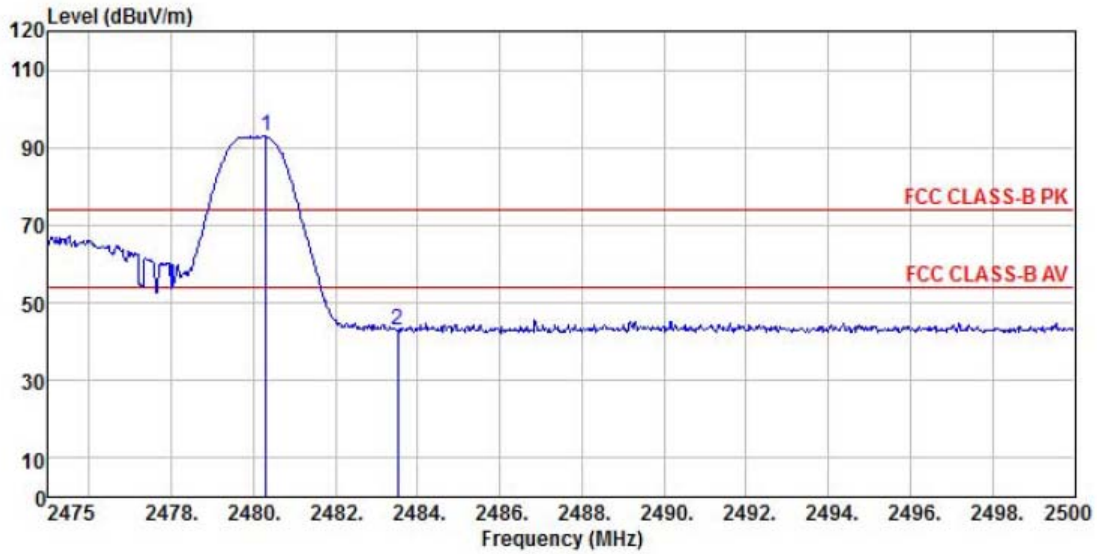

Site : chamber  
 Condition : FCC CLASS-B PK 3m BBHA9120D(942) VERTICAL  
 EUT :  
 Model Name : F800  
 Temp/Humi : 18 °C / 48 %  
 Power Rating:  
 Mode : BT CH39  
 Memo :

Read	Antenna	Cable	Preamp	Limit	Over
Freq	Level	Factor	Loss	Factor	Level
Line	Line	Line	Line	Line	Line

MHz	dBuV	dB/m	dB	dB	dBuV/m	dBuV/m	dB
1 pp 2480.30	96.39	27.52	7.41	38.31	93.01	74.00	19.01 Peak
2 2483.50	46.36	27.52	7.41	38.31	42.98	74.00	-31.02 Peak

Detector mode: Average

Polarity: Vertical

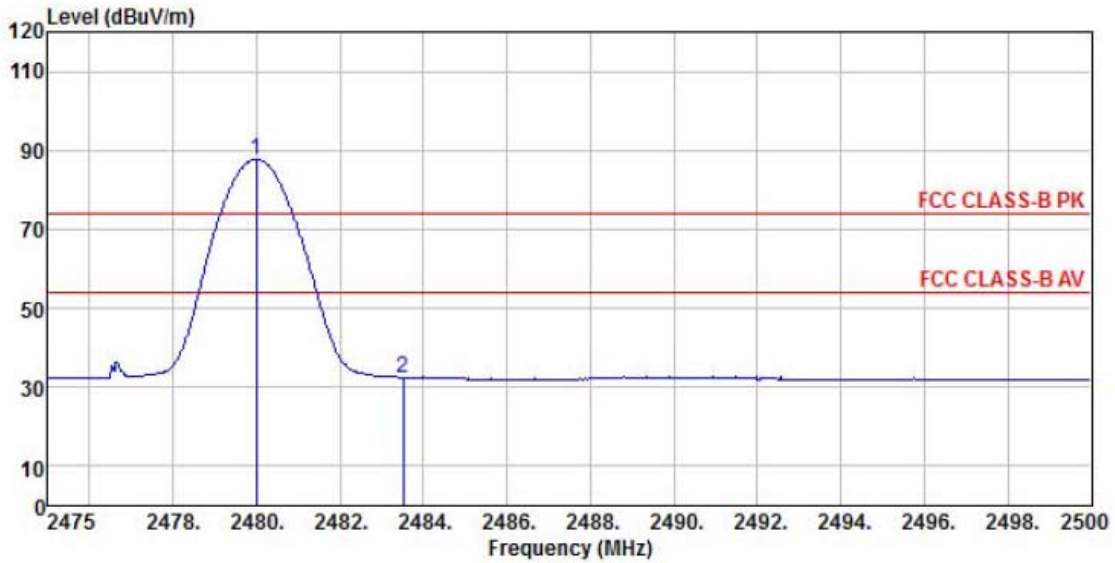

Site : chamber  
 Condition : FCC CLASS-B PK 3m BBHA9120D(942) VERTICAL  
 EUT :  
 Model Name : F800  
 Temp/Humi : 18 °C / 48 %  
 Power Rating:  
 Mode : BT CH39  
 Memo :

ReadAntenna Cable Preamp Limit Over  
 Freq Level Factor Loss Factor Level Line Limit Remark

MHz	dBuV	dB/m	dB	dB	dBuV/m	dBuV/m	dB
1 pp 2480.00	91.14	27.52	7.41	38.31	87.76	54.00	33.76 Average
2 2483.50	35.88	27.52	7.41	38.31	32.50	54.00	-21.50 Average



## 9. SPURIOUS EMISSIONS (RADIATION)

### 9.1 TEST SETUP

Radiated Spurious Measurement: below 30MHz

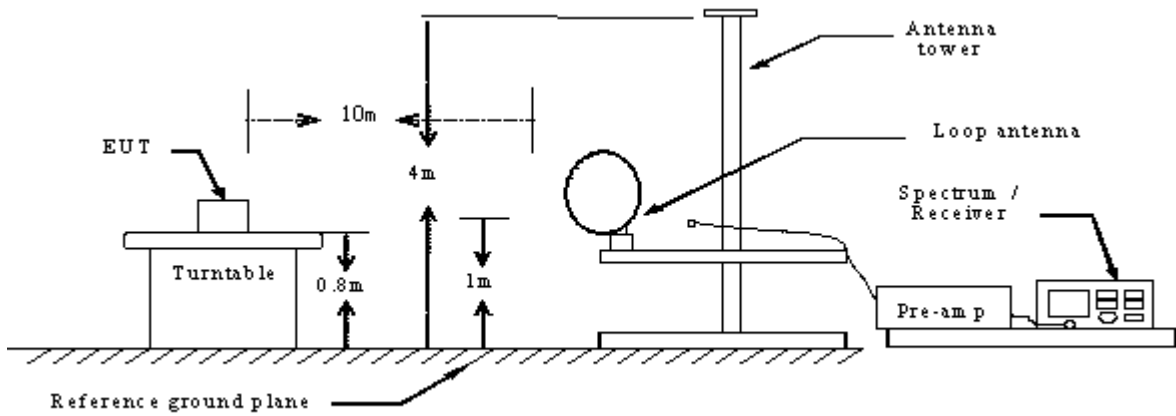

Radiated Spurious Measurement: below 1GHz

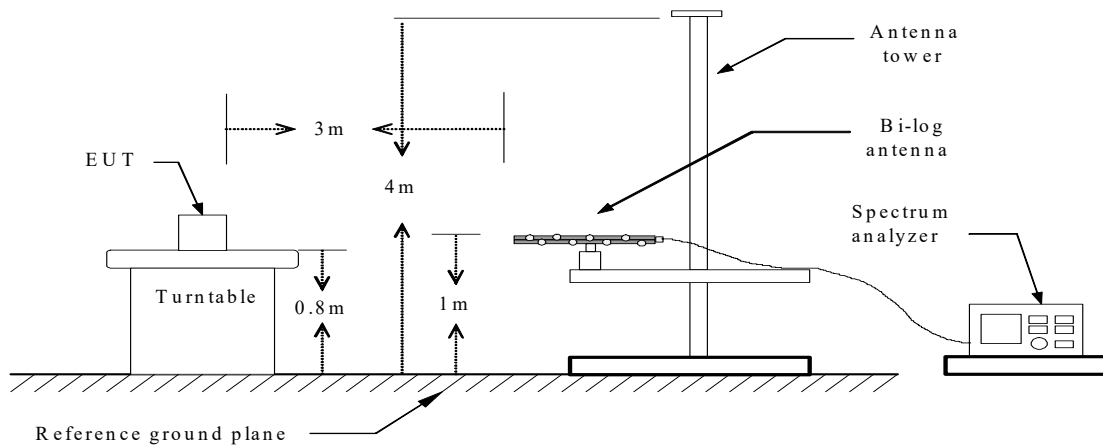

Radiated Spurious Measurement: above 1GHz

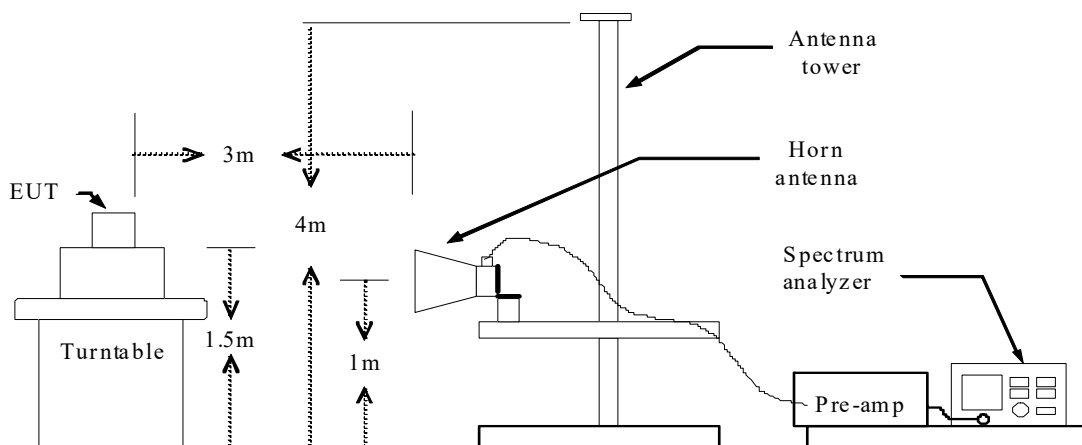

## 9.2 LIMITS

Frequency (MHz)	Limits (uV/m)	Limits(dBuV/m) At 3m	Measured Distance (m)
0.009-0.490	2400/F(KHz)	128.5-93.80	300
0.490-1.705	24000/F(KHz)	73.80-63.00	30
1.705-30.0	30	69.5	30
30~88	100	40	3
88~216	150	43.5	3
216-960	200	46	3
Above 960	500	54	3

Notes: the calculate formula for below 30MHz

$$L2 = 20\lg(L1) + 40\lg(d1/d2)$$

L2: is the specified limit in dB microvolts per metre at distance d2.

L1: is the specified limit in microvolts per metre at distance d1.

For example:

L1 = 2400/9 (uV/m), d1 = 300 (m), d2 = 3 (m), so L2 as follows:

$$20\lg(2400/9) + 40\lg(300/3) = 128.5(\text{dB}\mu\text{V/m})$$

## 9.3 TEST PROCEDURE

### Radiated Emission ( 9 kHz - 30 MHz ) :

Spurious emissions from the EUT are measured in the frequency range of 9 kHz to 30 MHz using a tuned receiver and a shielded loop antenna. The antenna was positioned 3 meters horizontally from the EUT. The RBW of the spectrum analyzer is set to 200Hz(measured frequency range was 9KHz~150KHz) or 9KHz(measured frequency range was 150KHz~30MHz). Measurements have been made in all three orthogonal axes and the shielded loop antenna was rotated to locate the maximum of the emissions. The emission limits are based on measurements employing a CISPR quasi-peak detector except for the frequency bands 9-90 kHz, 110-490 kHz (these two bands employing a average detector).

### Radiated Emission (30 MHz – 1000 MHz):

According to description of ANSI C63.4: 2014 sec.13.4, the preliminary radiated emissions measurement were carried out. The preliminary radiated measurements were performed at the measurement distance that specified for compliance to determine the emission characteristics of the EUT. The EUT configuration (in X, Y and Z axis), cable configuration and mode of operation were determined for producing the maximum level of emissions. These configurations were used for the final radiated emissions measurements. The measurement is carried out using a spectrum analyzer or receiver. The Quasi-peak detector is used and RBW is set to 120kHz. The antenna height and turn table rotation is adjusted until the maximum power value is founded on spectrum analyzer or receiver.

**Radiated Emission (Above 1 GHz):**

According to description of ANSI C63.4: 2014 sec.13.4, the preliminary radiated emissions measurement were carried out. The preliminary radiated measurements were performed at the measurement distance that specified for compliance to determine the emission characteristics of the EUT. The EUT configuration (in X, Y and Z axis), cable configuration and mode of operation were determined for producing the maximum level of emissions. These configurations were used for the final radiated emissions measurements. The measurement is carried out using a spectrum analyzer or receiver. The spectrum analyzer scans from 1GHz to 25GHz (higher than the 10<sup>th</sup> harmonic of the carrier). The peak detector is used for Peak limit and RBW is set to 1MHz ,VBW  $\geq$  3RBW. The peak detector is used for Average limit and RBW is set to 1MHz ,VBW is not smaller than 1/T, T = to the shortest pulse width. The antenna height and turn table rotation is adjusted until the maximum power value is founded on spectrum analyzer or receiver.

### 9.4 RESULTS & PERFORMANCE

**Test mode: Mode 1**

**From 9KHz to 30MHz:**

The test data was 20dB lower than the permissible limit was not recorded in the report.  
 802.11b, traffic mode; Channel 1

**From 30MHz to 1GHz:**

**Bluetooth V4.1 LE GFSK Channel 0**

Polarity: Horizontal

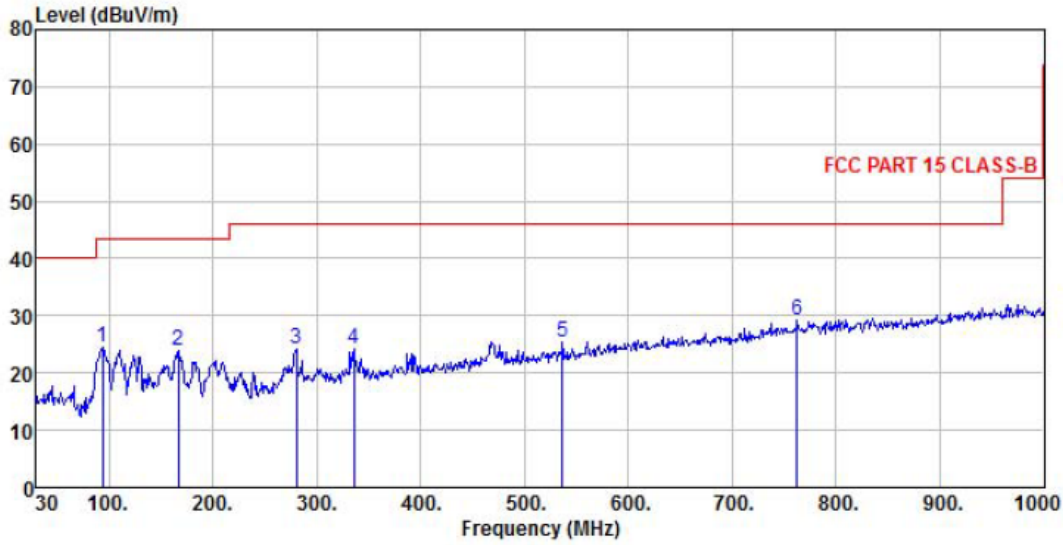

Site : chamber  
 Condition : FCC PART 15 CLASS-B 3m VULB9160 HORIZONTAL  
 EUT :  
 Model Name : F800  
 Temp/Humi : 17 °C /50 %  
 Power Rating:  
 Mode : BT CHO  
 Memo :

	Read	Antenna	Cable	Preamp	Limit	Over	
	Freq	Level	Factor	Loss	Factor	Level	Line
	MHz	dBuV	dB/m	dB	dB	dBuV/m	dBuV/m
1	94.02	13.71	9.74	1.18	0.00	24.63	43.50 -18.87 Peak
2	166.77	8.55	13.44	1.79	0.00	23.78	43.50 -19.72 Peak
3	280.26	9.34	12.81	2.20	0.00	24.35	46.00 -21.65 Peak
4	335.55	7.59	14.00	2.50	0.00	24.09	46.00 -21.91 Peak
5	536.34	4.62	17.61	3.12	0.00	25.35	46.00 -20.65 Peak
6 pp	762.35	4.08	21.38	3.70	0.00	29.16	46.00 -16.84 Peak

**Bluetooth V4.1 LE GFSK Channel 0**

Polarity: Vertical

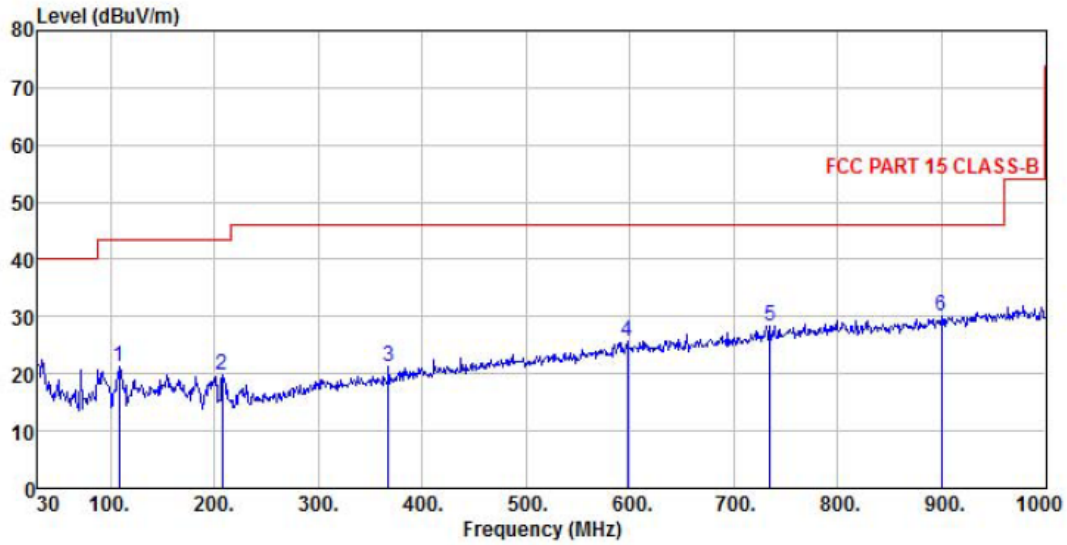

Site : chamber  
 Condition : FCC PART 15 CLASS-B 3m VULB9160 VERTICAL  
 EUT :  
 Model Name : F800  
 Temp/Humi : 17 °C /50 %  
 Power Rating:  
 Mode : BT CHO  
 Memo :

	Read	Antenna	Cable	Preamp	Limit	Over			
Freq	Level	Factor	Loss	Factor	Level	Line	Limit	Remark	
MHz	dBuV	dB/m	dB	dB	dBuV/m	dBuV/m	dB		
1	108.57	9.00	10.90	1.40	0.00	21.30	43.50	-22.20 Peak	
2	207.51	7.46	10.49	1.93	0.00	19.88	43.50	-23.62 Peak	
3	367.56	4.06	14.54	2.70	0.00	21.30	46.00	-24.70 Peak	
4	597.45	3.17	19.11	3.34	0.00	25.62	46.00	-20.38 Peak	
5	735.19	3.67	20.95	3.69	0.00	28.31	46.00	-17.69 Peak	
6 pp	900.09	3.33	22.58	4.06	0.00	29.97	46.00	-16.03 Peak	



**Bluetooth V4.1 LE GFSK Channel 19**

Polarity: Horizontal

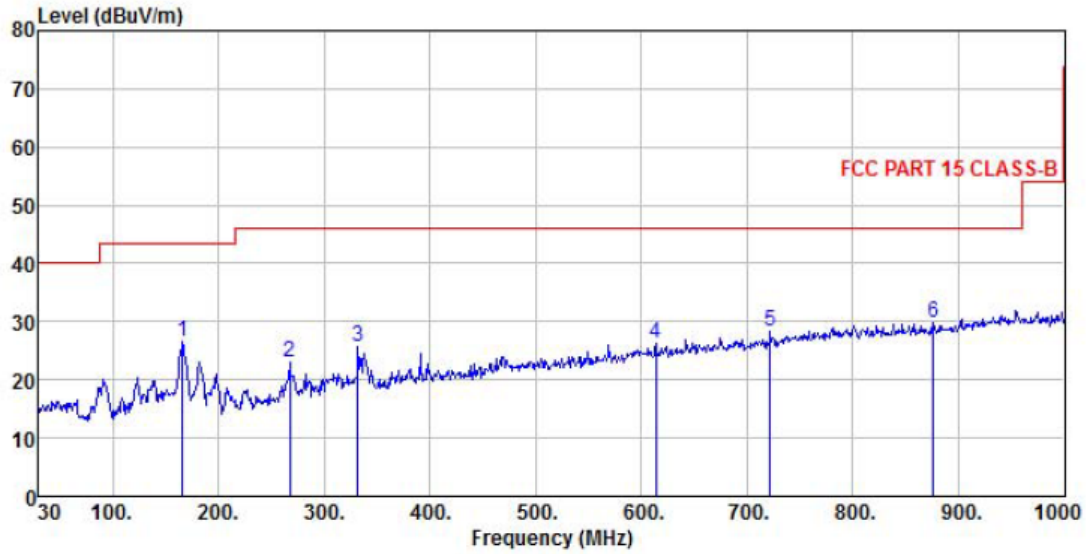

Site : chamber  
 Condition : FCC PART 15 CLASS-B 3m VULB9160 HORIZONTAL  
 EUT :  
 Model Name : F800  
 Temp/Humi : 17 °C /50 %  
 Power Rating:  
 Mode : BT CH19  
 Memo :

ReadAntenna Cable Preamp Limit Over  
 Freq Level Factor Loss Factor Level Line Limit Remark

	MHz	dBuV	dB/m	dB	dB	dBuV/m	dBuV/m	dB
1	165.80	11.36	13.55	1.77	0.00	26.68	43.50	-16.82 Peak
2	267.65	8.36	12.40	2.21	0.00	22.97	46.00	-23.03 Peak
3	331.67	9.42	13.91	2.48	0.00	25.81	46.00	-20.19 Peak
4	613.94	3.83	19.19	3.39	0.00	26.41	46.00	-19.59 Peak
5	721.61	4.17	20.56	3.68	0.00	28.41	46.00	-17.59 Peak
6 pp	875.84	3.73	22.09	3.96	0.00	29.78	46.00	-16.22 Peak

**Bluetooth V4.1 LE GFSK Channel 19**

Polarity: Vertical

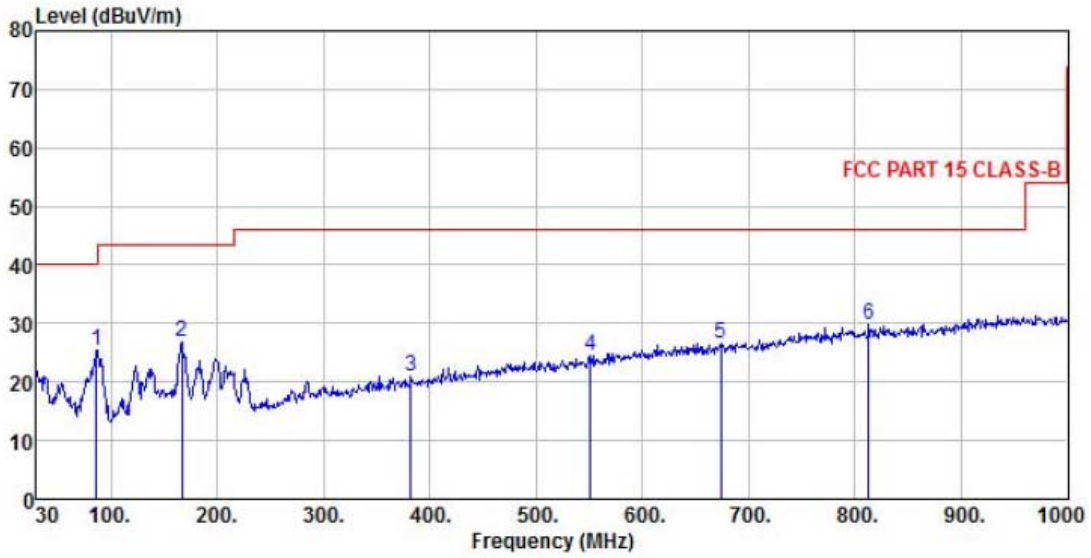

Site : chamber  
 Condition : FCC PART 15 CLASS-B 3m VULB9160 VERTICAL  
 EUT :  
 Model Name : F800  
 Temp/Humi : 17 °C /50 %  
 Power Rating:  
 Mode : BT CH19  
 Memo :

	Read	Antenna	Cable	Preamp	Limit	Over		
	Freq	Level	Factor	Loss	Factor	Level	Line	Limit
	MHz	dBuV	dB/m	dB	dB	dBuV/m	dBuV/m	dB
1	pp	86.26	15.50	8.89	1.09	0.00	25.48	40.00 -14.52
2		166.77	11.65	13.44	1.79	0.00	26.88	43.50 -16.62
3		382.11	3.41	14.92	2.75	0.00	21.08	46.00 -24.92
4		550.89	3.37	17.92	3.18	0.00	24.47	46.00 -21.53
5		674.08	3.21	19.82	3.56	0.00	26.59	46.00 -19.41
6		812.79	4.14	21.85	3.82	0.00	29.81	46.00 -16.19

**Bluetooth V4.1 LE GFSK Channel 39**

Polarity: Horizontal

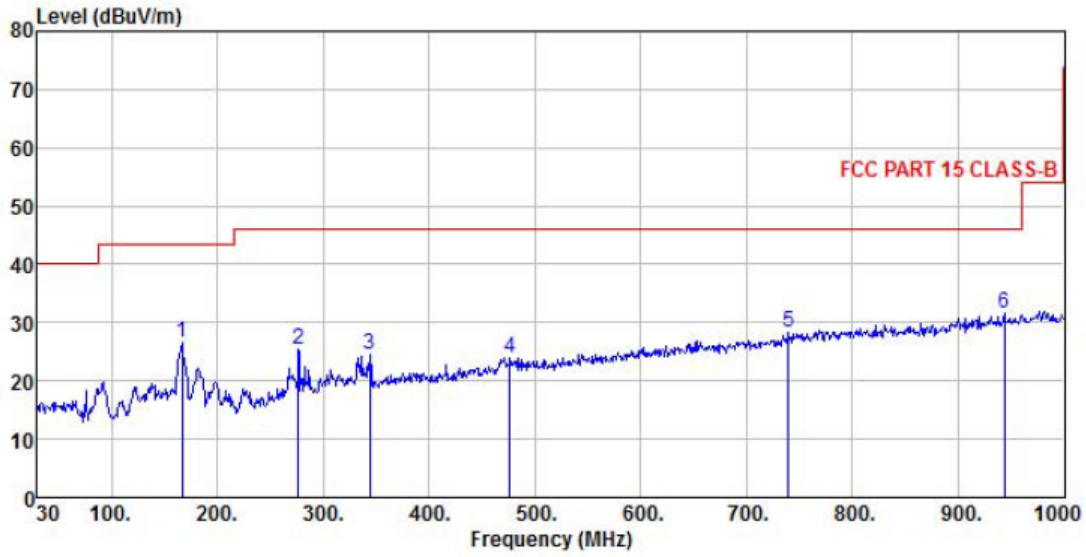

Site : chamber  
 Condition : FCC PART 15 CLASS-B 3m VULB9160 HORIZONTAL  
 EUT :  
 Model Name : F800  
 Temp/Humi : 17 °C /50 %  
 Power Rating:  
 Mode : BT CH39  
 Memo :

	Read	Antenna	Cable	Preamp	Limit	Over	
Freq	Level	Factor	Loss	Factor	Level	Line	Limit Remark
MHz	dBuV	dB/m	dB	dB	dBuV/m	dBuV/m	dB
1	166.77	11.24	13.44	1.79	0.00	26.47	43.50 -17.03 Peak
2	276.38	10.50	12.67	2.21	0.00	25.38	46.00 -20.62 Peak
3	344.28	7.74	14.17	2.54	0.00	24.45	46.00 -21.55 Peak
4	476.20	4.27	16.81	2.97	0.00	24.05	46.00 -21.95 Peak
5	740.04	3.46	21.06	3.77	0.00	28.29	46.00 -17.71 Peak
6 pp	943.74	4.09	23.31	4.13	0.00	31.53	46.00 -14.47 Peak

**Bluetooth V4.1 LE GFSK Channel 39**

Polarity: Vertical

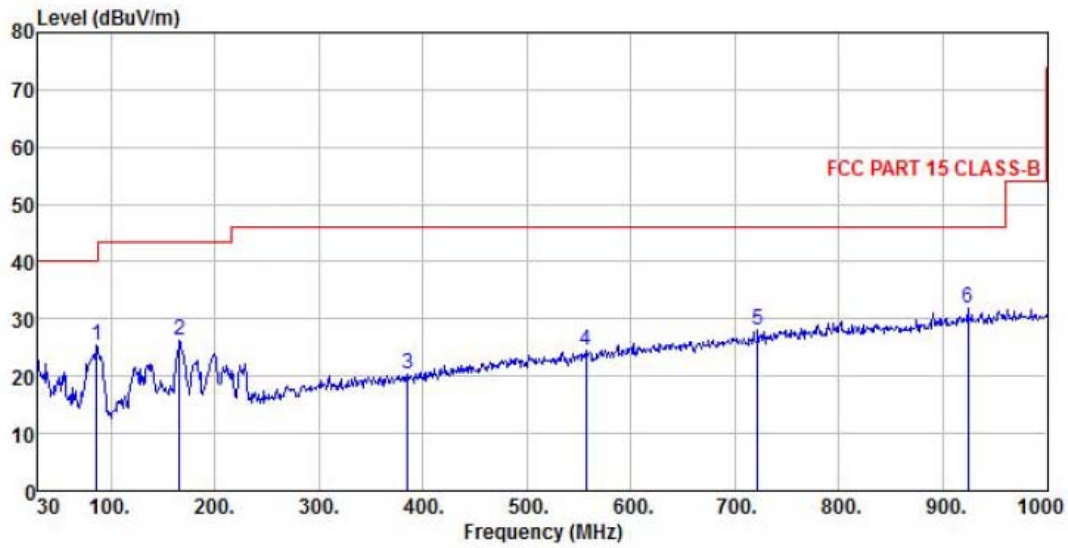

Site : chamber  
 Condition : FCC PART 15 CLASS-B 3m VULB9160 VERTICAL  
 EUT :  
 Model Name : F800  
 Temp/Humi : 17 °C /50 %  
 Power Rating:  
 Mode : BT CH39  
 Memo :

ReadAntenna Cable Preamp Limit Over  
 Freq Level Factor Loss Factor Level Line Limit Remark

	MHz	dBuV	dB/m	dB	dB	dBuV/m	dBuV/m	dB
1	86.26	15.49	8.89	1.09	0.00	25.47	40.00	-14.53 Peak
2	165.80	11.08	13.55	1.77	0.00	26.40	43.50	-17.10 Peak
3	385.02	2.60	14.97	2.73	0.00	20.30	46.00	-25.70 Peak
4	556.71	3.31	18.07	3.22	0.00	24.60	46.00	-21.40 Peak
5	721.61	3.68	20.56	3.68	0.00	27.92	46.00	-18.08 Peak
6 pp	924.34	4.76	22.92	4.10	0.00	31.78	46.00	-14.22 Peak

**From 1GHz to 25GHz:**

Only show the worst test data when EUT was operated on different mode.

EUT operation mode : BT GFSK(Ch0/Ch19/Ch39)

**Bluetooth V4.1 LE GFSK Channel 0**

Frequency (MHz)	Reading (dBuV)	Correct Factor(dB)	Antenna Polarity	Total (dBuV/m)	Limit (dBuV/m)	Margin (dB)	Detector Type
2402	104.89	-3.55	Horizontal	100.45	/	/	Peak
4804	41.67	4.72	Horizontal	46.39	74	27.61	Peak
7206	43.83	10.83	Horizontal	54.66	74	19.34	Peak
2402	105.15	-3.55	Vertical	101.60	/	/	Peak
4804	39.94	4.72	Vertical	44.66	74	29.34	Peak
7206	41.88	10.83	Vertical	52.71	74	21.29	Peak

Note:

- 1, Total=Reading + Correct factor;
- 2, 2402 MHz was fundamental signal which can be ignored;
- 3, Average measurement was not performed if peak level were lower than the average limit;
- 4, Other harmonics are lower than background noise.

## 10. AC POWER LINE CONDUCTED EMISSIONS

### 10.1 TEST SETUP

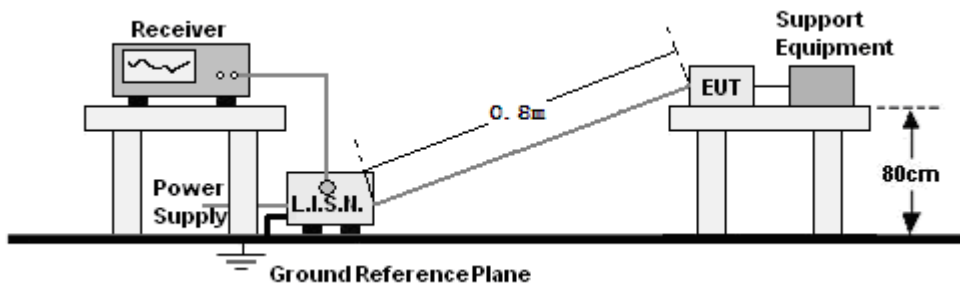

### 10.2 LIMITS

Frequency range (MHz)	Limits dB(μV)	
	Quasi-peak	Average
0,15 to 0,50	66 to 56	56 to 46
0,50 to 5	56	46
5 to 30	60	50

- NOTE:** 1. The lower limit shall apply at the transition frequencies.  
 2. The limit decreases linearly with the logarithm of the frequency in the range 0.15 to 0.50 MHz.

### 10.3 TEST PROCEDURE

According to description of ANSI C63.4: 2009 sec.13.1.3, the AC power line preliminary conducted emissions measurements were carried out. The preliminary conducted measurements were performed using the spectrum analyzer to observe the emission characteristics of the EUT. The EUT configuration, cable configuration and mode of operation were determined for producing the maximum level of emissions. These configurations were used for final AC power line conducted emissions measurements. The EUT is placed on a non-metallic table 0.8m above the horizontal metal reference ground plane. The EUT is connected to LISN and LISN is connected to the reference ground. All other supplemental devices are connected with EUT through other LISN. The distance between EUT and LISN is 80cm. A radio link is established between EUT and the tester. The output power of the EUT is controlled by the tester and driven to maximum value. An initial pre-scan was performed on the live L line and neutral line with peak detector (9kHz RBW ). Both average detector and quasi-peak detector are performed at the frequencies with maximized peak emission. Conducted emissions were investigated over the frequency range from 0.15MHz to 30MHz using a receiver bandwidth of 9kHz.

### 10.4 RESULTS & PERFORMANCE

Only show the worst test data when EUT was operated on different mode.  
 EUT operation mode: Ch0/Ch19/Ch39

**Test mode: Mode 1**

**Bluetooth V4.1 LE GFSK Channel 0**

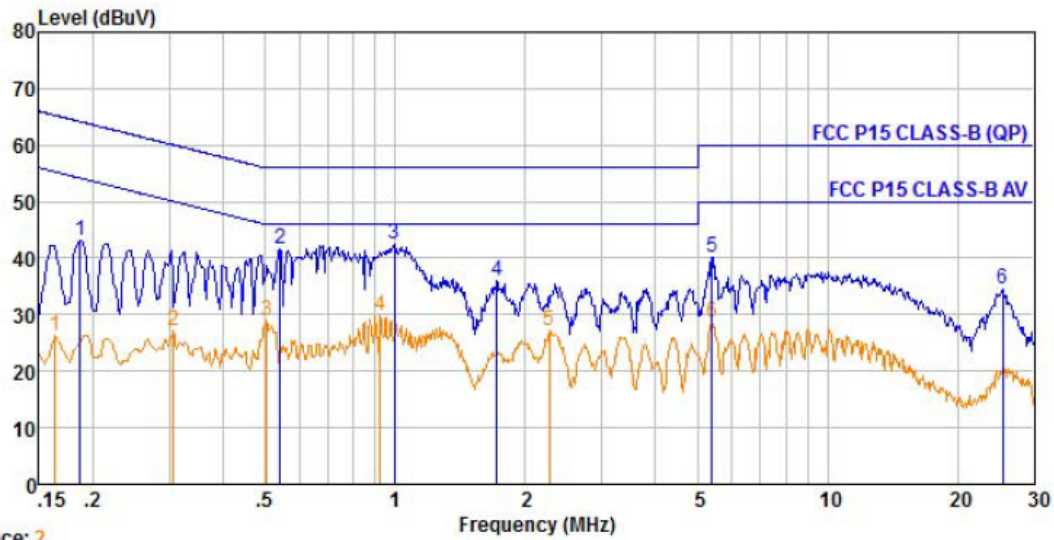

Trace: 2  
 Site : chamber  
 Condition : FCC P15 CLASS-B (QP) ENV216(L) LINE  
 EUT :  
 Model Name : F800  
 Temp/Humi : 17°C / 50 %  
 Power Rating:  
 Mode : BT CH0  
 Memo :

MHz	dBUV	dB	dB	dB	Read		Limit		Over	Line	Limit	Remark
					Factor	Loss	Factor	Level				
1	0.19	33.43	9.46	0.23	0.00	43.12	64.20	-21.08	Peak			
2	0.54	31.66	9.73	0.11	0.00	41.50	56.00	-14.50	Peak			
3	pp	0.99	32.70	9.67	0.14	0.00	42.51	56.00	-13.49	Peak		
4	1.72	26.14	9.68	0.15	0.00	35.97	56.00	-20.03	Peak			
5	5.39	30.43	9.65	0.17	0.00	40.25	60.00	-19.75	Peak			
6	25.46	24.01	10.28	0.12	0.00	34.41	60.00	-25.59	Peak			



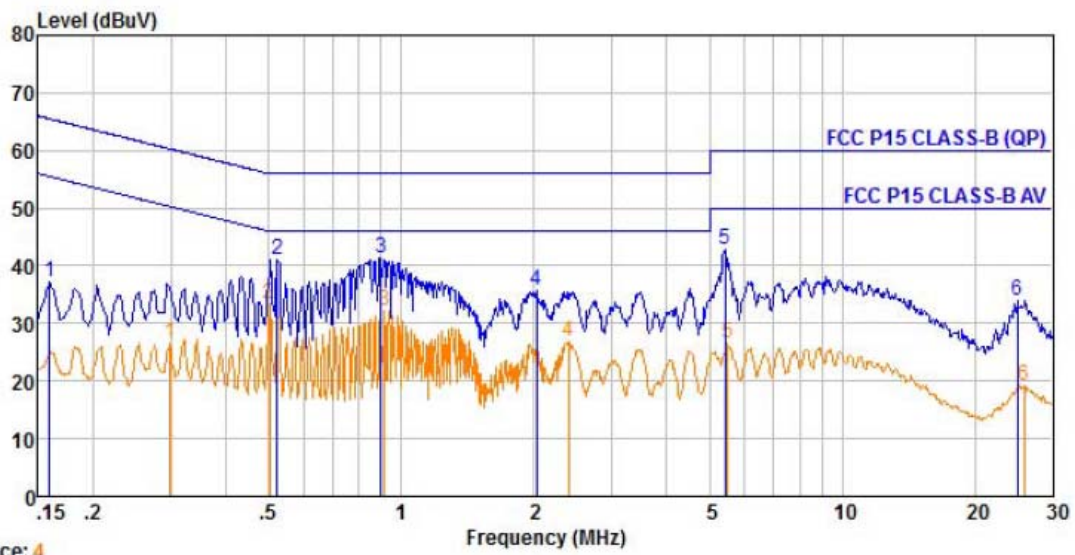

Trace: 4  
 Site : chamber  
 Condition : FCC P15 CLASS-B (QP) ENV216(N) NEUTRAL  
 EUT :  
 Model Name : F800  
 Temp/Humi : 17°C / 50 %  
 Power Rating:  
 Mode : BT CHO  
 Memo :

		Read	LISN	Cable	Preamp	Limit	Over			
Freq	Level	Factor	Loss	Factor	Level	Line	Limit	Remark		
MHz	dBuV	dB	dB	dB	dBuV	dBuV	dB			
1	0.16	27.49	9.63	0.09	0.00	37.21	65.52	-28.31	Peak	
2	0.52	31.53	9.53	0.10	0.00	41.16	56.00	-14.84	Peak	
3	pp	0.90	31.67	9.64	0.13	0.00	41.44	56.00	-14.56	Peak
4		2.02	25.80	9.64	0.15	0.00	35.59	56.00	-20.41	Peak
5		5.42	33.00	9.54	0.18	0.00	42.72	60.00	-17.28	Peak
6		24.92	23.76	9.95	0.12	0.00	33.83	60.00	-26.17	Peak



### Bluetooth V4.1 LE GFSK Channel 19

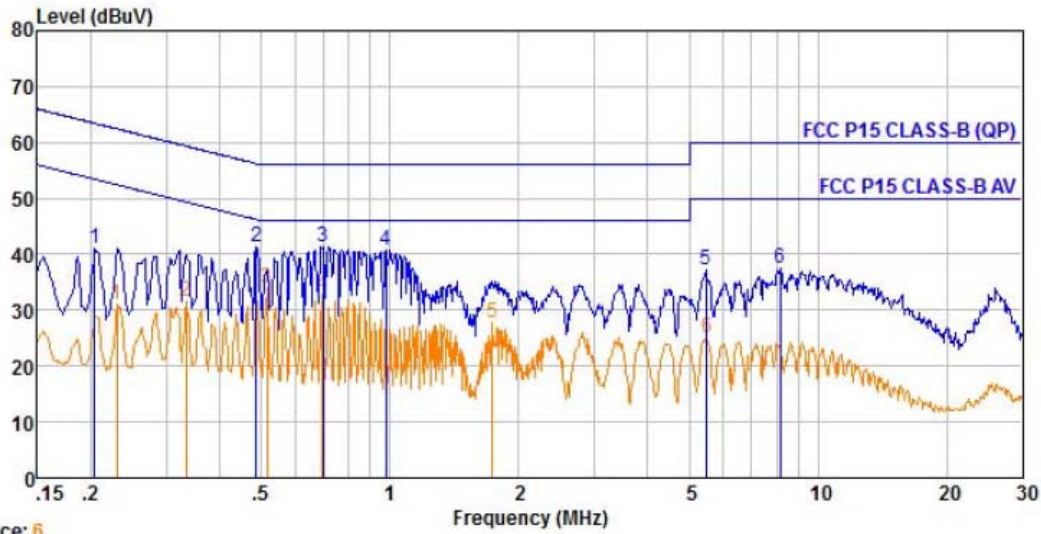

Trace: 6  
 Site : chamber  
 Condition : FCC P15 CLASS-B (QP) ENV216(L) LINE  
 EUT :  
 Model Name : F800  
 Temp/Humi : 17°C / 50 %  
 Power Rating:  
 Mode : BT CH19  
 Memo :

MHz	dBuV	dB	dB	dB	Read LISN Cable Preamp		Limit Over		Remark	
					Level	Factor	Level	Line		
1	0.20	31.31	9.46	0.22	0.00	40.99	63.45	-22.46	Peak	
2	0.49	31.47	9.75	0.10	0.00	41.32	56.23	-14.91	Peak	
3	pp	0.70	31.61	9.68	0.12	0.00	41.41	56.00	-14.59	Peak
4	0.98	30.96	9.67	0.14	0.00	40.77	56.00	-15.23	Peak	
5	5.48	27.26	9.65	0.18	0.00	37.09	60.00	-22.91	Peak	
6	8.15	27.67	9.67	0.29	0.00	37.63	60.00	-22.37	Peak	

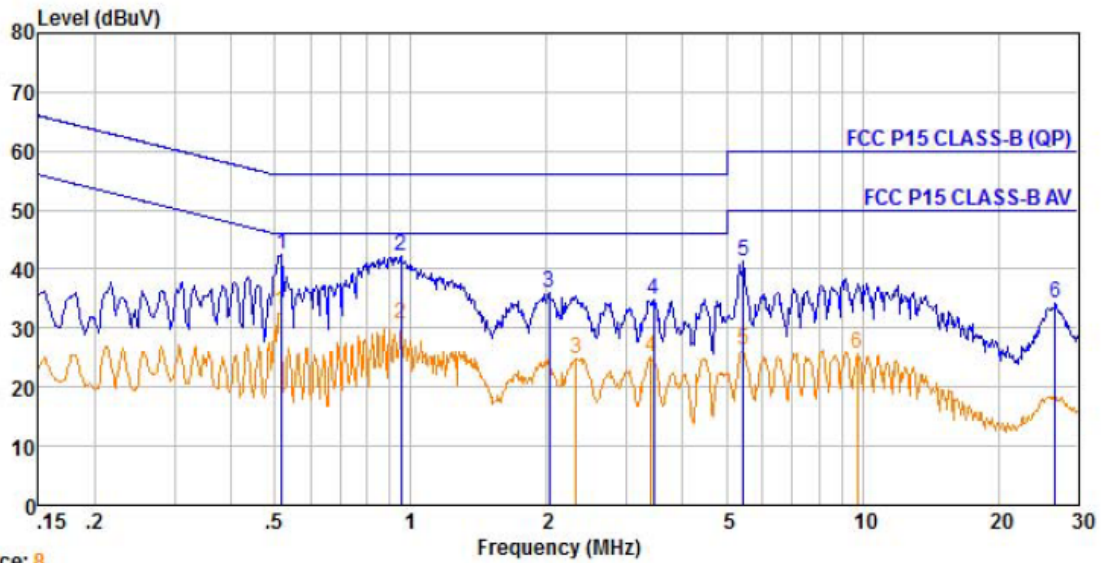

Trace: 8

Site : chamber  
 Condition : FCC P15 CLASS-B (QP) ENV216(N) NEUTRAL  
 EUT :  
 Model Name : F800  
 Temp/Humi : 17°C / 50 %  
 Power Rating:  
 Mode : BT CH19  
 Memo :

Read	LISN	Cable	Preamp	Limit	Over
Freq	Level	Factor	Loss	Factor	Level
MHz	dBuV	dB	dB	dB	dBuV

MHz	dBuV	dB	dB	dB	dBuV	dBuV	dB
1 pp	0.52	33.00	9.53	0.10	0.00	42.63	56.00 -13.37 Peak
2	0.95	32.30	9.64	0.14	0.00	42.08	56.00 -13.92 Peak
3	2.02	26.20	9.64	0.15	0.00	35.99	56.00 -20.01 Peak
4	3.45	25.14	9.59	0.15	0.00	34.88	56.00 -21.12 Peak
5	5.45	31.48	9.55	0.18	0.00	41.21	60.00 -18.79 Peak
6	26.70	24.04	10.18	0.12	0.00	34.34	60.00 -25.66 Peak

**Bluetooth V4.1 LE GFSK Channel 39**

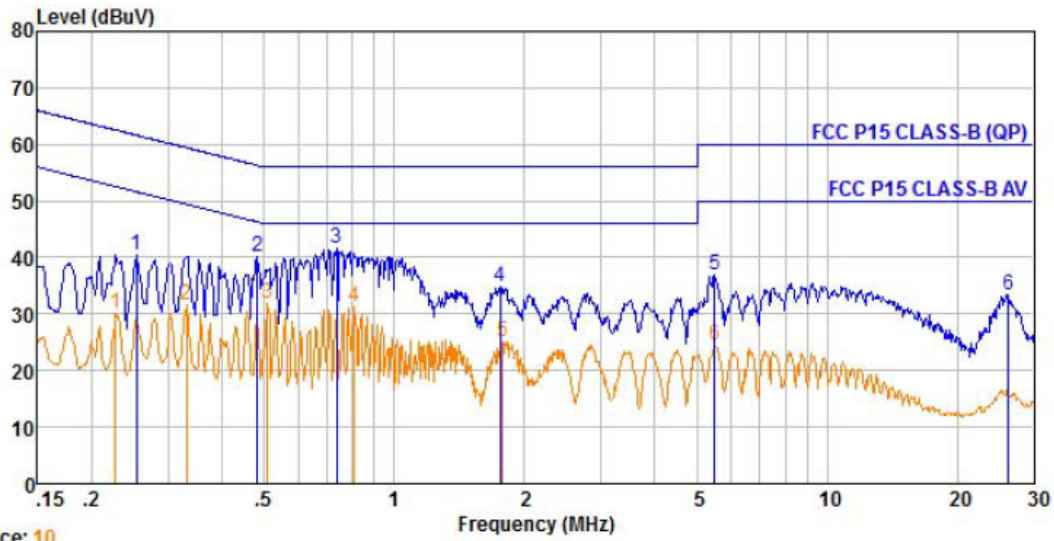

Trace: 10  
 Site : chamber  
 Condition : FCC P15 CLASS-B (QP) ENV216(L) LINE  
 EUT :  
 Model Name : F800  
 Temp/Humi : 17°C / 50 %  
 Power Rating:  
 Mode : BT CH39  
 Memo :

MHz	dBUV	dB	dB	dB	Limit		dB	Remark
					Level	Line		
1	0.25	30.80	9.52	0.20	0.00	40.52	61.64	-21.12 Peak
2	0.48	30.44	9.75	0.10	0.00	40.29	56.27	-15.98 Peak
3 pp	0.74	31.73	9.68	0.12	0.00	41.53	56.00	-14.47 Peak
4	1.75	25.01	9.68	0.15	0.00	34.84	56.00	-21.16 Peak
5	5.51	27.03	9.65	0.19	0.00	36.87	60.00	-23.13 Peak
6	26.28	23.09	10.21	0.12	0.00	33.42	60.00	-26.58 Peak

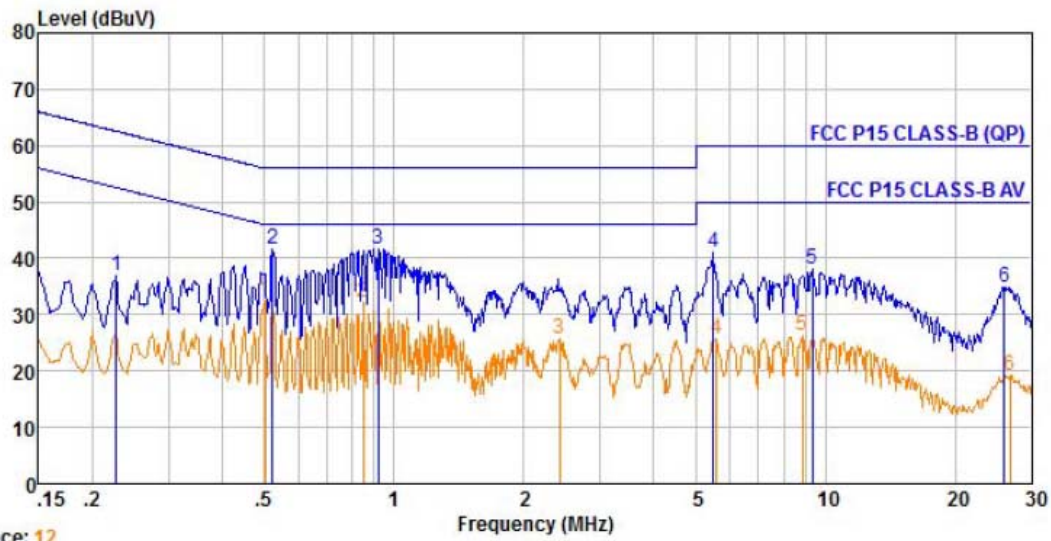

Trace: 12  
 Site : chamber  
 Condition : FCC P15 CLASS-B (QP) ENV216(N) NEUTRAL  
 EUT :  
 Model Name : F800  
 Temp/Humi : 17°C / 50 %  
 Power Rating:  
 Mode : BT CH39  
 Memo :

Read LISN Cable Preamp Limit Over  
 Freq Level Factor Loss Factor Level Line Limit Remark

	MHz	dBuV	dB	dB	dB	dBuV	dBuV	dB
1	0.23	27.29	9.43	0.22	0.00	36.94	62.57	-25.63 Peak
2	0.52	31.93	9.53	0.10	0.00	41.56	56.00	-14.44 Peak
3 pp	0.92	31.92	9.64	0.13	0.00	41.69	56.00	-14.31 Peak
4	5.51	31.25	9.55	0.19	0.00	40.99	60.00	-19.01 Peak
5	9.30	28.32	9.62	0.25	0.00	38.19	60.00	-21.81 Peak
6	26.00	24.76	10.09	0.12	0.00	34.97	60.00	-25.03 Peak

## **APPENDIX 1 PHOTOGRAPHS OF TEST SETUP**

Please refer to the file named "Part 15C Setup Photos".

## **APPENDIX 2 PHOTOGRAPHS OF EUT**

Please refer to the files named "EUT External Photos" and "EUT Internal Photos".

----End of the report----