

7.1 Combination instrument

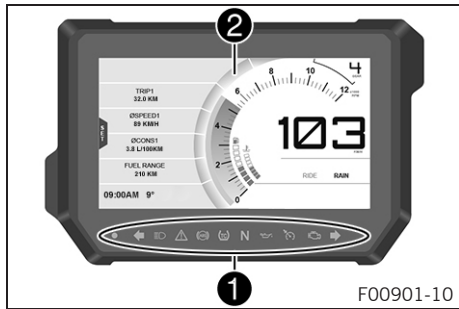

The combination instrument is attached in front of the handlebar.
The combination instrument is divided into two function areas.

① indicator lamps (📖 p. 50)

Display ②



Warning

Danger of burns Parts of the combination instrument become very hot in certain situations.

The display becomes particularly hot in the case of external temperatures above 55 °C (131 °F), extended periods in standing position, e.g. at a traffic light, or in direct sunlight.

- Do not touch the combination instrument with bare hands in the situations referred to.
- Where appropriate protective clothing.
- If you have been burned, hold the area affected under lukewarm water immediately.

7.2 Activation and test



Activation

The combination instrument is activated when the ignition is switched on.



Info

The brightness of the displays is controlled by a brightness sensor in the combination instrument.

Test

The welcome text appears on the display and the indicator lamps are briefly activated for a function test.

7.3 Day-Night mode

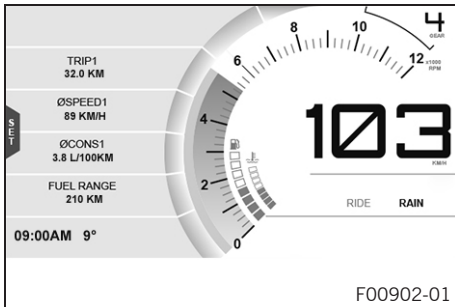

Day mode is shown in a bright color.

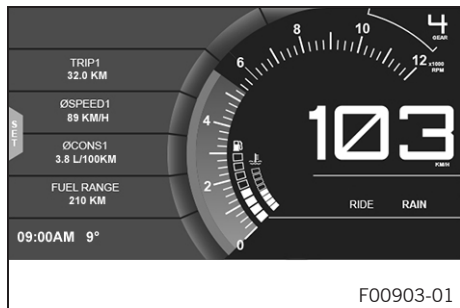

Night mode is shown in a dark color.



Info

The light sensor in the combination instrument measures the brightness of the environment and automatically switches the display to day or night mode. The display is brightened, darkened or switched to the other mode depending on the brightness measured by the light sensor.

The display mode cannot be changed manually.

7.4 Warning notes

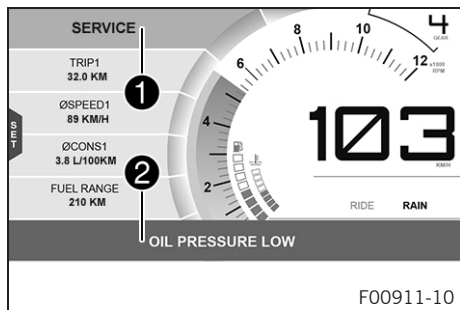

Warning notes appear on the top and/or bottom edge of the display, these are marked yellow or red depending on their relevance.

Yellow warning notes ① indicate errors or information which requires prompt intervention or an adjustment to the riding style.

Red warning notes ② indicate errors or information which requires immediate intervention.



Info

Warning notes are cleared by pressing any button.

All existing warning notes are displayed in the **Warnings** menu until these are no longer active.

7.5 Warning of icy roads

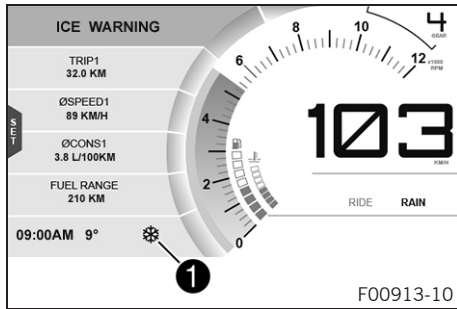

The ice symbol ❄ goes on when there is an increased risk of ice on the roads.

The ice symbol ❄ is shown in area ❶ of the display.

The ice symbol ❄ appears on the display when the ambient temperature drops below the specified value.

Temperature	3 °C (37 °F)
-------------	--------------

The ice symbol ❄ goes out on the display when the ambient temperature rises back up above the specified value.

Temperature	6 °C (43 °F)
-------------	--------------



Info

If the ice symbol ❄ lights up, the warning note **ICE WARNING** also appears.











7.6 Indicator lamps



7 COMBINATION INSTRUMENT

The indicator lamps offer additional information about the operating state of the motorcycle.
When the ignition is switched on, all indicator lamps light up briefly.

Possible states

	Race-on indicator lamp lights up/flashes yellow/orange/red – Status or error messages relating to Race-on system/alarm system.
	The left turn signal indicator lamp flashes green with a steady rhythmic flash – The left turn signal is switched on.
	The high beam indicator lamp lights up blue – The high beam is switched on.
	The general warning lamp lights up yellow – An operating safety (warning) message was detected. This is also shown on the display.
	ABS indicator lamp lights up yellow – Status or error messages relating to <u>ABS</u> . The ABS indicator lamp flashes if the ABS mode Offroad is enabled.
	TC indicator lamp lights up/flashes yellow – The motorcycle traction control is not enabled or is currently intervening. The TC Indicator lamp also lights up if an error is detected. In addition, the TC indicator lamp flashes if the HHC (📖 p. 113) (optional) is active.
	The idle indicator lamp lights up green – The transmission is in idle.
	The oil pressure warning lamp lights up red – The oil pressure is too low.
	The cruise control system lamp lights up yellow – The cruise control system function is switched on, but the speed control is not active.
	The cruise control system lamp lights up green – The cruise control system function is switched on and the speed control is active.
	Malfunction indicator lamp lights up yellow – The <u>OBD</u> has detected an emission- or safety-critical fault.

7 COMBINATION INSTRUMENT



The right turn signal indicator lamp flashes green with a steady rhythmic flash – The right turn signal is switched on.

7 COMBINATION INSTRUMENT

7.7 Display

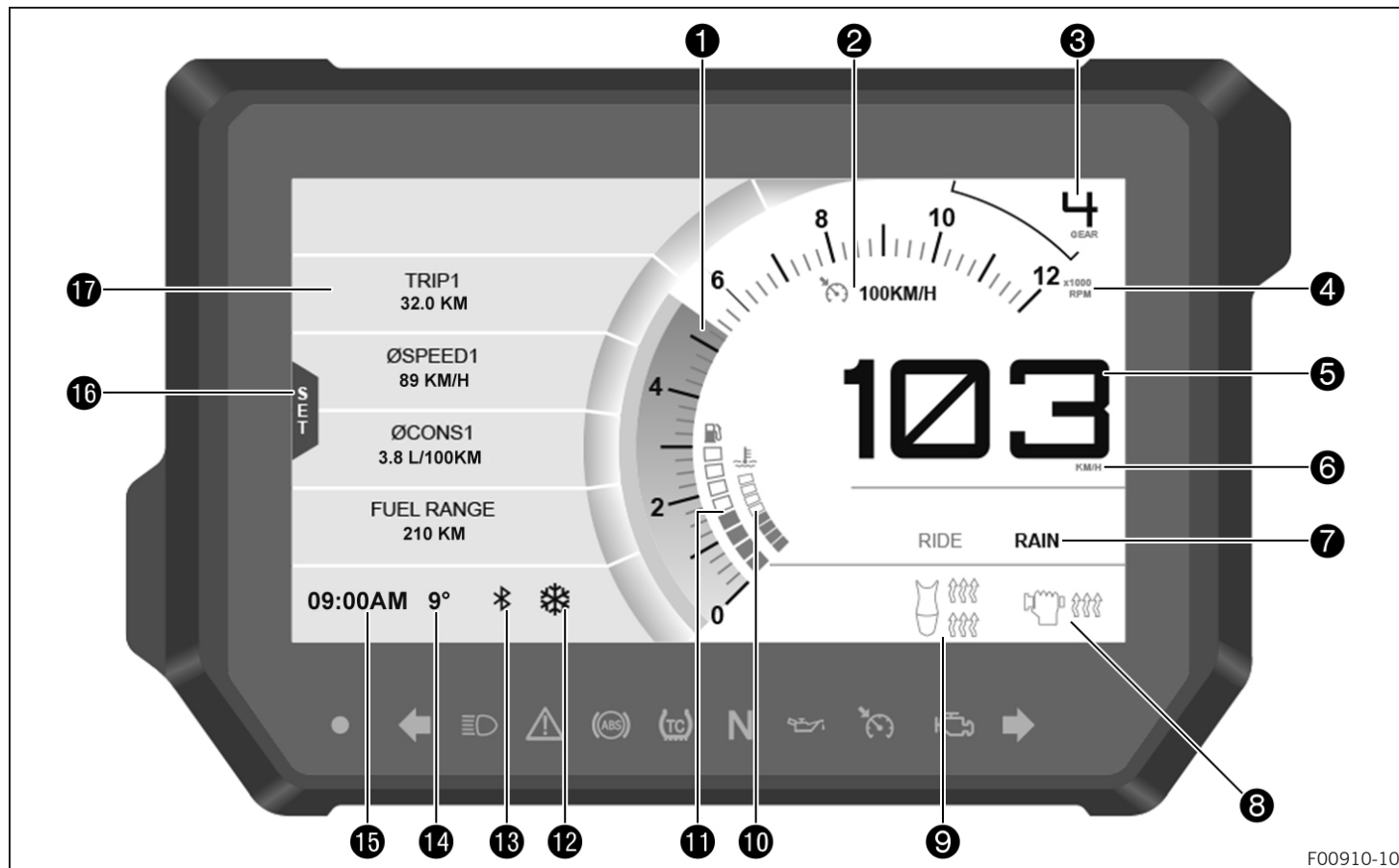

 **Info**
The figure shows the standard display of the combination instrument. If the menu is opened, the speed is still displayed.

1	Speed (📖 p. 56)
1	Shift warning light (📖 p. 57) The shift warning light is integrated in the tachometer display.
2	Cruise control indicator (📖 p. 58)
3	Gear display
4	Unit for the speed display
5	Speed (📖 p. 58)
6	Unit for the speedometer
7	Ride Mode display (📖 p. 59)
8	Heated grip (optional) (📖 p. 59)
9	Sitzbankheizung (optional) (📖 p. 60)
10	Coolant temperature indicator (📖 p. 60)
11	Fuel level display (📖 p. 61)
12	Warning of icy roads (📖 p. 49) Only shown when there is an increased risk of ice on the roads.
13	Bluetooth ® (optional)
14	Ambient temperature indicator (📖 p. 61)
15	Time (📖 p. 62)
16	SET Only shown where the menu overview is closed.
17	Favourites display (📖 p. 62)

7 COMBINATION INSTRUMENT

7.8 Speed

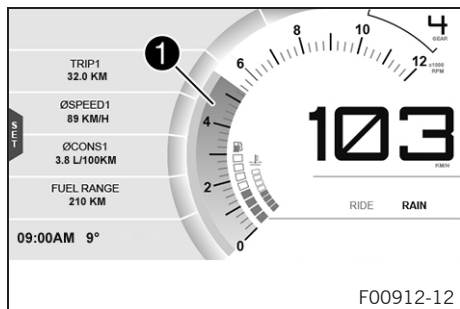

The speed ① is measured in revolutions per minute.

7.9 Shift warning light

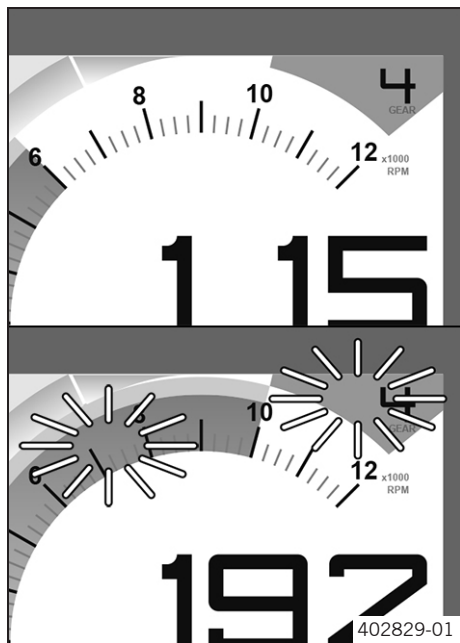

The shift warning light is integrated in the tachometer display.

In the **Shift Light** menu, the engine speed for the shift warning light can be set. The shift warning light is always active during the running-in phase (up to 1,000 km / 621 mi). The shift warning light can only be deactivated, and the values for **RPM1** and **RPM2** can only be adjusted after this. The shift warning light lights up red at **RPM1** and flashes red at **RPM2**.



Info

In sixth-gear, the shift warning light is deactivated when the engine is warm after the first service.

Coolant temperature	≤ 35 °C (≤ 95 °F)
ODO	< 1,000 km (< 620 mi)
The shift warning light always lights up at	6,500 rpm
Coolant temperature	> 35 °C (> 95 °F)
ODO	> 1,000 km (> 620 mi)
RPM1 shift warning light	lights up
RPM2 shift warning light	flashes

7.10 Cruise control indicator

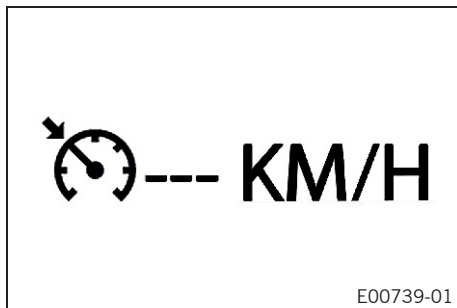

When cruise control is activated, the operating mode is shown on the combination instrument display.

Cruise control is operated using the cruise control tip switch (📖 p. 28).

7.11 Speed

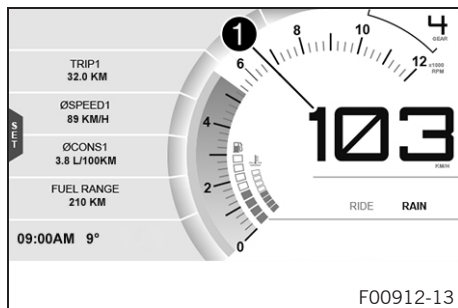

7.12 Ride Mode display

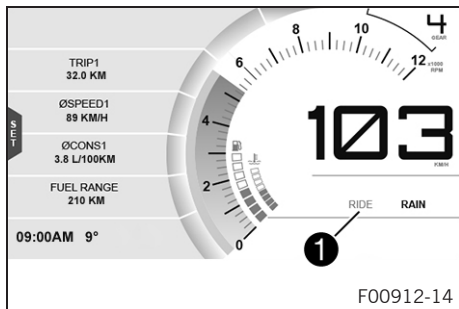

The **Ride Mode** setting is shown in area ❶ of the display.
The drive mode can be configured in the **Ride Mode** menu.

7.13 Heated grip (optional)

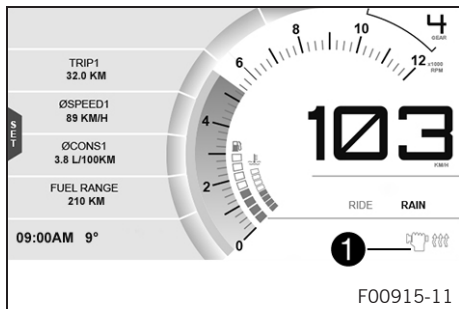

When the heated grip is switched on, the **Heated Grips** symbol appears in the ❶ area of the display.
The heated grip can be configured in the **Heated Grips** menu.

7.14 Sitzbankheizung (optional)

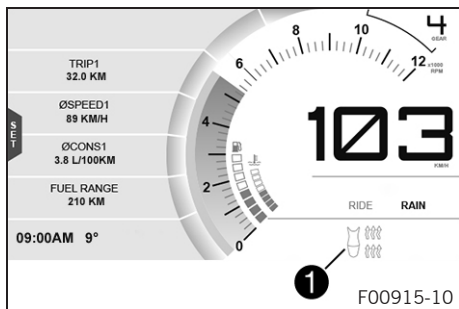

When the seat heating is switched on, the **Heated Seats** symbol appears in the **1** area of the display.

The seat heating can be configured in the **Heated Seat** menu.



Info

The heating level for the passenger seat heating can be controlled by a switch next to the right grab handle.

7.15 Coolant temperature indicator

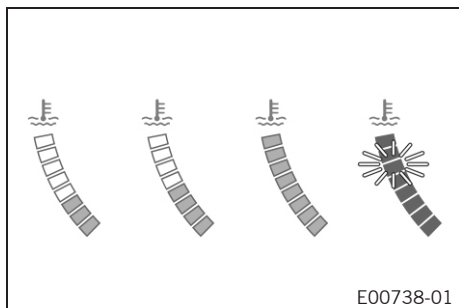

The coolant temperature indicator consists of bars. The more bars that light up, the hotter the coolant.



Info

When all bars flash, the following warning note **ENGINE TEMP HIGH** appears.

Possible states

- The engine is cold – Up to three bars light up.
- Engine warm – Four bars light up.
- Engine hot – Five to eight bars light up.
- Engine very hot – all eight bars flash red.

7.16 Fuel level display

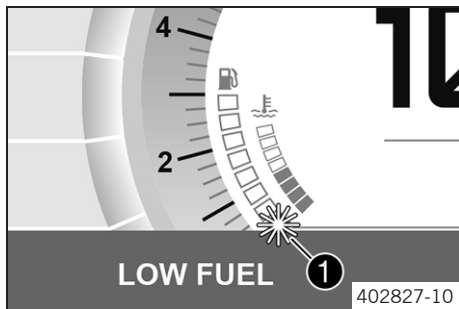

The fuel tank contents are shown in area ❶ of the display.

The fuel level indicator consists of bars. The more bars are lit, the more fuel is in the fuel tank.

i Info

If the fuel level is getting low, the last segment flashes red and the following warning note also appears **LOW FUEL**.

The fuel level is displayed with a slight delay to prevent the indicator from constantly moving while riding.

The fuel level display is not updated while the side stand is folded out or the emergency off switch is switched off.

Once the side stand is folded up and emergency OFF switch is switched on, the fuel level display is next updated after 2 minutes.

The fuel level display flashes if the combination instrument does not receive a signal from the fuel level sensor.

7.17 Ambient temperature indicator

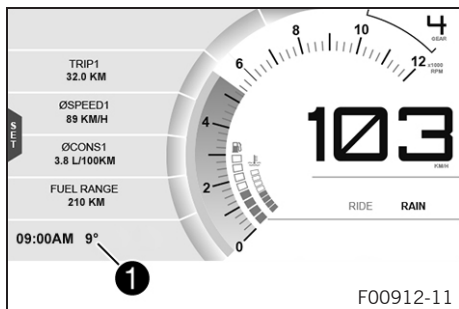

The ambient temperature ❶ is displayed in °C or °F.

7.18 Time

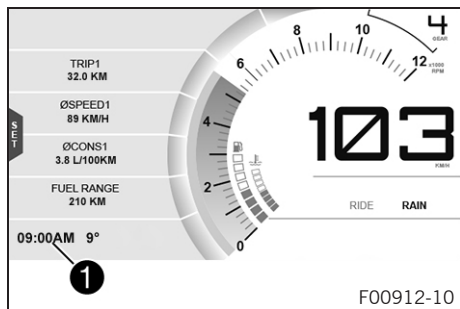

The time is shown in area ❶ of the display.

The time is displayed in 24 hour format in all languages except for EN-US. The time is displayed in 12 hour format if the language is set to EN-US.

The time can be configured in the **Clock/Date** menu.



Info

The time must be reset after the battery was disconnected or the fuse was removed.

7.19 Favourites display

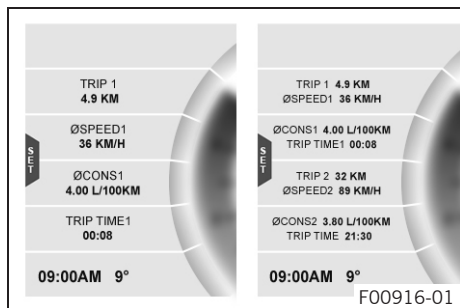

Up to eight items of information are shown in the **Favourites** display.

The **Favourites** display can be freely configured in the **Favourites** menu.



Info

One to four items of information selected are displayed on two lines. Five to eight items of information selected are displayed on a single line.

7.20 Quick Selector 1 display

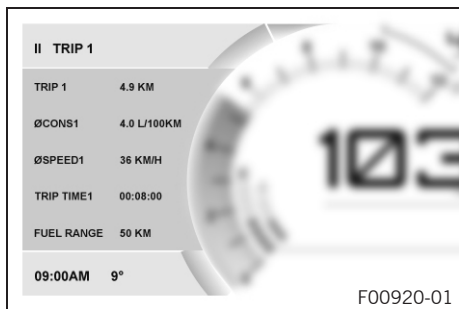

When the menu is closed, the **Quick Selector 1** menu is opened by pressing the **UP** button. Press the **BACK** button to close **Quick Selector 1**.



Info

The **Quick Selector 1** can be configured in the **Quick Selector 1** menu. Any information can be selected.

7.21 Quick Selector 2 display

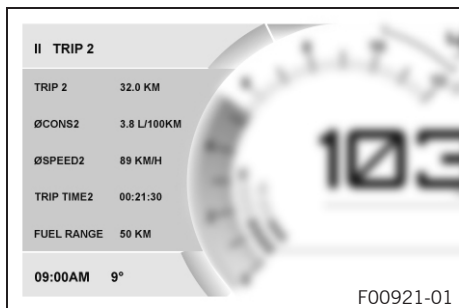

When the menu is closed, the **Quick Selector 2** menu is opened by pressing the **DOWN** button.

Press the **BACK** button to close **Quick Selector 2**.



Info

The **Quick Selector 2** can be configured in the **Quick Selector 2** menu. Any information can be selected.

7.22 Menu

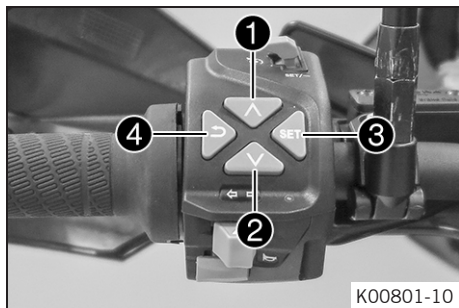

Info

Press the **SET** button ① in the standard display to open the menu. Navigate through the menu using the **UP** button ② or the **DOWN** button ③. Press the **BACK** button ④ to close the current menu or the menu overview.

7.22.1 KTM MY RIDE (optional)

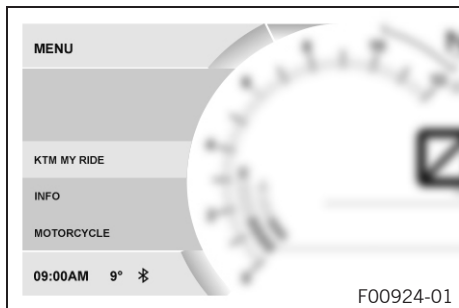

Condition

- The motorcycle is stationary.
- Function **KTM MY RIDE** activated (optional).
 - Press the **SET** button when the menu is closed.
 - Press the **UP** or **DOWN** button until **KTM MY RIDE** is marked. Press the **SET** button to open the menu.

In **KTM MY RIDE** an appropriate cellphone or headset can be paired with the combination instrument via **Bluetooth®**.



Info

Not every cellphone and headset is suitable for pairing with the combination instrument. The standard **Bluetooth®** 2.1 must be supported.

7.22.2 Info

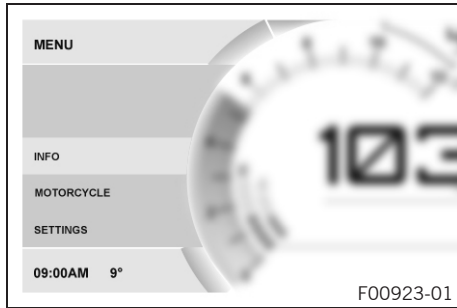

- Press the **SET** button when the menu is closed.
- Press the **UP** or **DOWN** button until **Info** is marked. Press the **SET** button to open the menu.

General information can be accessed in **Info**.

7.22.3 Motorcycle

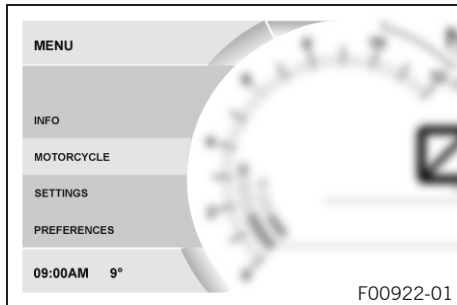

Condition

- The motorcycle is stationary.
- Press the **SET** button when the menu is closed.
- Press the **UP** or **DOWN** button until **Motorcycle** is marked. Press the **SET** button to open the menu.

The vehicle drive mode can be configured in **Motorcycle**.

7.22.4 Settings

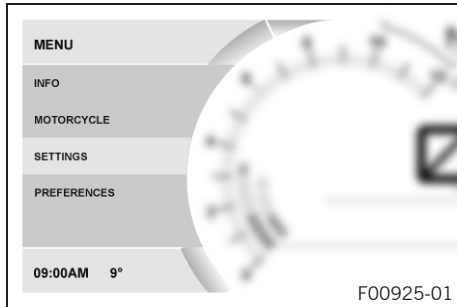

Condition

- The motorcycle is stationary.
- Press the **SET** button when the menu is closed.
- Press the **UP** or **DOWN** button until **Settings** is marked. Press the **SET** button to open the menu.

Favorites and quick selection can be configured in **Settings**.

7.22.5 Preferences

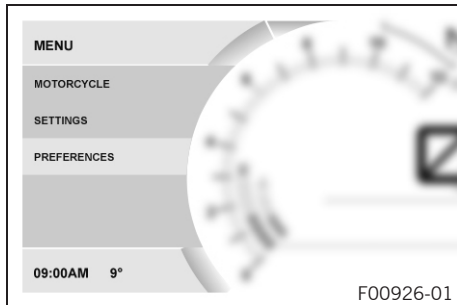

Condition

- The motorcycle is stationary.
- Press the **SET** button when the menu is closed.
- Press the **UP** or **DOWN** button until **Preferences** is marked. Press the **SET** button to open the menu.

The combination instrument display can be configured in **Preferences**. Settings can be made for units or various values. Several functions can be enabled or disabled.

7.22.6 Pairing (optional)

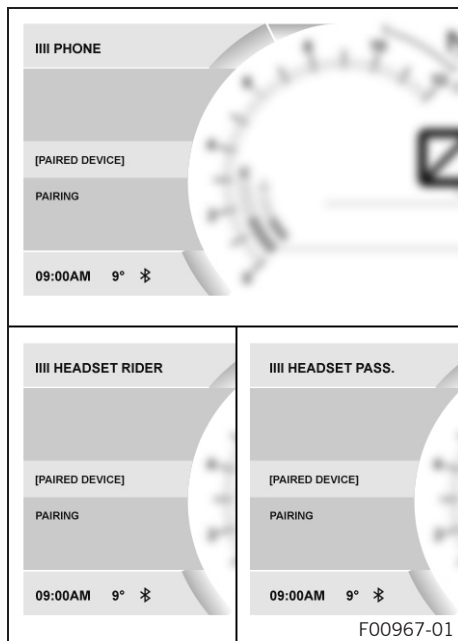

Condition

- The motorcycle is stationary.
- Function **KTM MY RIDE** activated (optional).
- Similarly, the **Bluetooth®** function should also be activated in the device to be paired.
 - Press the **SET** button when the menu is closed.
 - Press the **UP** or **DOWN** button until **KTM MY RIDE** is marked. Press the **SET** button to open the menu.
 - Press the **UP** or **DOWN** button until **Setup** is marked. Press the **SET** button to open the menu.
 - Press the **UP** or **DOWN** button until **Bluetooth** is marked. Press the **SET** button to open the menu.
 - Press the **UP** or the **DOWN** button until menu item **Phone**, **Headset Rider** or **Headset Pass.** is marked.



Info

Two cellphones can never be paired simultaneously with the combination instrument. Only one cellphone and one headset per submenu item can be paired with the combination instrument at the same time.

- A suitable cellphone can be paired with the combination instrument in the **Phone** submenu.
- A suitable rider headset can be paired with the combination instrument in the **Headset Rider** submenu.
- A suitable passenger headset can be paired with the combination instrument in the **Headset Pass.** submenu.



Info

The following steps are identical for cellphones and headsets.

- Press the **SET** button.
- When pairing the device for the first time, press the **UP** or **DOWN** button until **Pairing** is marked. Press the **SET** button to open the menu.
- Navigate to the device required using the **UP** or **DOWN** button. Confirm the selection using the **SET** button.
- Confirmation of the **Passkey** successfully completes the pairing.

i Info

When a suitable device has been successfully paired, the name of the paired cellphone or headset appears in each case in the **Phone**, **Headset Rider** or **Headset Pass.** menu.

Press the **UP** or **DOWN** button until paired device is marked on the display. The paired device can be deleted by pressing the **SET** button.

The device most recently linked is automatically paired with the combination instrument when **Bluetooth®** is switched on and as soon as this device is in range and has not been previously deleted.

Not every cellphone or headset is suitable for pairing with the combination instrument.

7.22.7 Audio (optional)

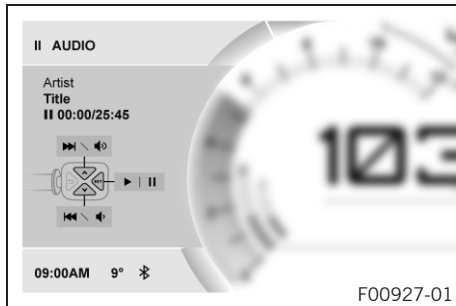

Condition

- Function **KTM MY RIDE** activated (optional).
- Similarly, the **Bluetooth®** function should also be activated in the device to be paired.
- Press the **SET** button when the menu is closed.
- Press the **UP** or **DOWN** button until **KTM MY RIDE** is marked. Press the **SET** button to open the menu.

**Warning**

Danger of accidents Headphone volume which is too high distracts attention from traffic activity.

- Always select headphone volume which is low enough for you to still clearly hear acoustic signals.

-
- Press the **UP** or **DOWN** button until **Audio** is marked. Press the **SET** button to open the menu.
 - Press and hold the **UP** button to increase the audio volume.
 - Press and hold the **DOWN** button to reduce the audio volume.
 - Press the **UP** button briefly to change to the next audio track.
 - Press the **DOWN** button briefly to change to the previous audio track.
 - Press the **SET** button to play or pause the audio track.

**Info**

The audio function can be added to **Quick Selector 1** or **Quick Selector 2** for easier operation.

7.22.8 Telephony (optional)

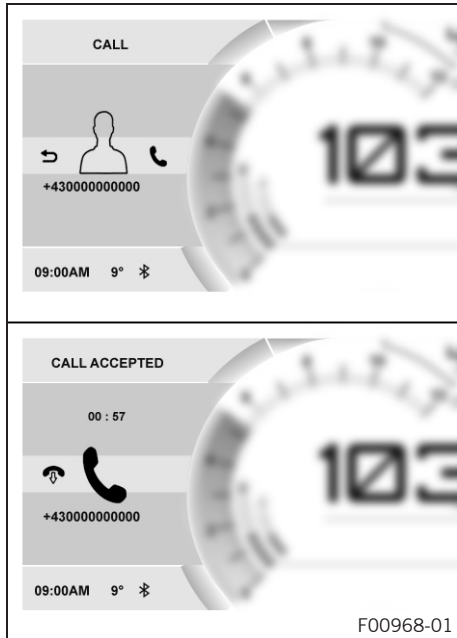

Condition

- **KTM MY RIDE** Function activated (optional).
- Similarly, the **Bluetooth®** function should also be activated in the device to be paired.
- Headset linked with appropriate cellphone.



Warning

Danger of accidents Headphone volume which is too high distracts attention from traffic activity.

- Always select headphone volume which is low enough for you to still clearly hear acoustic signals.

- Press the **SET** button to accept an incoming call.
- Press the **BACK** button to reject an incoming call.
- Press and hold the **UP** button to increase the audio volume.
- Press and hold the **DOWN** button to reduce the audio volume.



Info

The call duration and contact are displayed. Depending on the cellphone settings, the contact is shown by name.

7.22.9 Trip 1

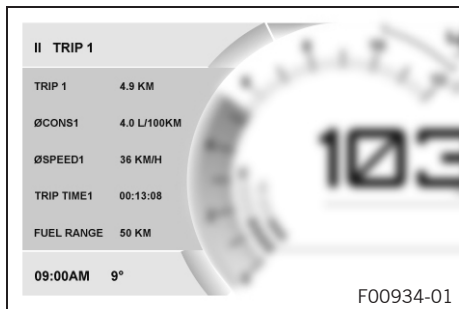

- Press the **SET** button when the menu is closed.
- Press the **UP** or **DOWN** button until **Info** is marked. Press the **SET** button to open the menu.
- Press the **UP** or **DOWN** button until **Trip 1** is marked. Press the **SET** button to open the menu.

Trip 1 shows the distance since the last reset, such as between two refueling stops. **Trip 1** is running and counts up to **9999**.

ØCons1 indicates the average fuel consumption based on **Trip 1**.

ØSpeed1 indicates the average speed based on **Trip 1** and **Trip Time1**.

Trip Time1 shows the journey time on the basis of **Trip 1** and runs as soon as a speed signal is received.

Fuel Range indicates the possible distance you can cover with the fuel reserve.

Press and hold the **SET** button for 3-5 seconds.

All entries in the **Trip 1** menu are reset.

7.22.10 Trip 2

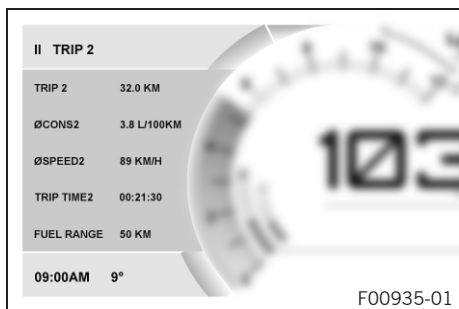

- Press the **SET** button when the menu is closed.
- Press the **UP** or **DOWN** button until **Info** is marked. Press the **SET** button to open the menu.
- Press the **UP** or **DOWN** button until **Trip 2** is marked. Press the **SET** button to open the menu.

Trip 2 shows the distance since the last reset, such as between two refueling stops. **Trip 2** is running and counts up to **9999**.

ØCons2 indicates the average fuel consumption based on **Trip 2**.

ØSpeed2 indicates the average speed based on **Trip 2** and **Trip Time2**.

Trip Time2 shows the journey time on the basis of **Trip 2** and runs as soon as a speed signal is received.

Fuel Range indicates the possible distance you can cover with the fuel reserve.

Press and hold the **SET** button for 3-5 seconds.

All entries in the **Trip 2** menu are reset.

7.22.11 General Info

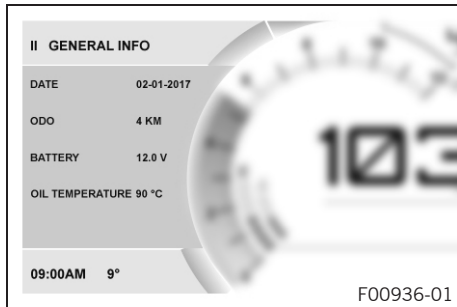

- Press the **SET** button when the menu is closed.
- Press the **UP** or **DOWN** button until **Info** is marked. Press the **SET** button to open the menu.
- Press the **UP** or **DOWN** button until **General Info** is marked. Press the **SET** button to open the menu.

Date shows the date.

ODO shows the total distance covered.

Battery indicates the battery voltage.

Oil Temperature indicates the engine oil temperature.

7.22.12 TPMS

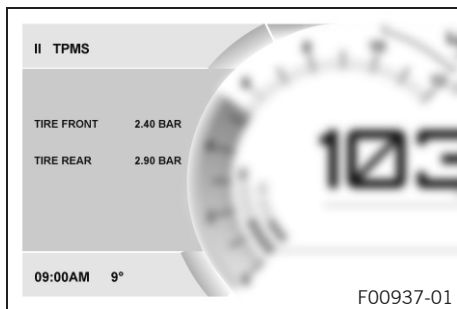

Condition

- Model with **TPMS**.
- Press the **SET** button when the menu is closed.
- Press the **UP** or **DOWN** button until **Info** is marked. Press the **SET** button to open the menu.

**Warning**

Danger of accidents The tire pressure control system does not eliminate the necessity to check the tires before going on a ride.

To avoid false alarms, the tire pressure values are evaluated over a period of several minutes.

- Check the tire pressure before every ride.
- Correct the tire pressure if the tire pressure deviates from the specified value.
- Even if the tire pressure values are correct, stop the vehicle immediately if its behavior indicates a pressure loss in the tires.

-
- Press the **UP** or **DOWN** button until the **TPMS** menu appears in the display.

Guideline

Tire air pressure, solo/with passenger/full payload	
Front: with cold tires	2.4 bar (35 psi)
Rear: with cold tires	2.9 bar (42 psi)

The **TPMS** menu displays the tire air pressure of the front and rear tires.

TIRE FRONT indicates the tire air pressure at the front.

TIRE REAR indicates the tire air pressure at the rear.

7.22.13 Warnings

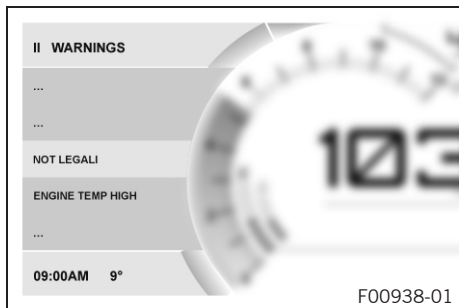

Condition

- Message or warning is present.
- Press the **SET** button when the menu is closed.
- Press the **UP** or **DOWN** button until **Info** is marked. Press the **SET** button to open the menu.
- Press the **UP** or **DOWN** button until **Warnings** is marked. Press the **SET** button to open the menu.
- Use the **UP** or **DOWN** button to navigate through the warnings.

In the **Warnings** menu, all warnings that have occurred are displayed and stored.

7.22.14 Heated Grips (optional)

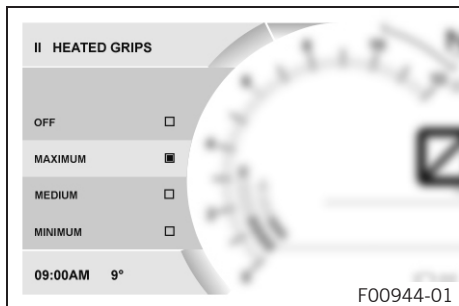

Condition

- The motorcycle is stationary.
- Menu **Heated Grips** activated.
- Press the **SET** button when the menu is closed.
- Press the **UP** or **DOWN** button until **Motorcycle** is marked. Press the **SET** button to open the menu.
- Press the **UP** or **DOWN** button until **Heated Grips** is marked. Press the **SET** button to open the menu.
- Activate the menu item using the **UP** or **DOWN** button.
- Press the **SET** button to select the heating level or to switch the heated grip on or off.

7.22.15 Heated Seat (optional)

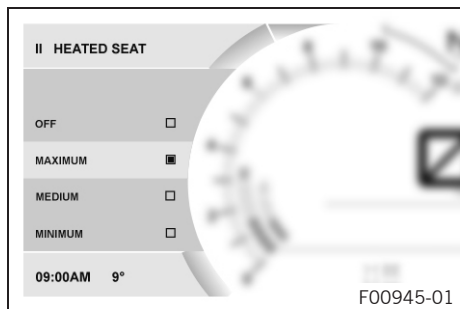

Condition

- The motorcycle is stationary.
 - Menu **Heated Seat Ride** activated.
 - Menu **Heated Seat Pas** activated.
- Press the **SET** button when the menu is closed.
 - Press the **UP** or **DOWN** button until **Motorcycle** is marked. Press the **SET** button to open the menu.
 - Press the **UP** or **DOWN** button until **Heated Seat** is marked. Press the **SET** button to open the menu.
 - Activate the menu item using the **UP** or **DOWN** button.
 - Press the **SET** button to select the heating level or to switch the seat heating on or off.



Info

The heating level for the passenger seat heating is selected using the switch next to the right grab handle.

7.22.16 Ride Mode

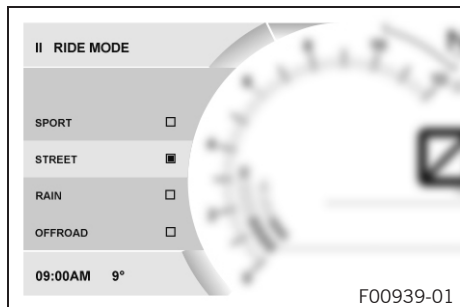

- Press the **SET** button when the menu is closed.
 - Press the **UP** or **DOWN** button until **Motorcycle** is marked. Press the **SET** button to open the menu.
 - Press the **UP** or **DOWN** button until **Ride Mode** is marked. Press the **SET** button to open the menu.
 - Press the **UP** or **DOWN** button to activate the menu item and select it with the **SET** button. By pressing the **SET** button, engine and traction control settings that are coordinated with each other can be selected.
- ✓ **SPORT** – homologated performance with very direct response; the traction control allows greater slip on the rear wheel.

- ✓ STREET – homologated performance with balanced response; the traction control allows normal slip on the rear wheel.
- ✓ RAIN – reduced homologated performance for better ridability; the traction control allows normal slip on the rear wheel.
- ✓ OFFROAD – reduced homologated performance for better ridability; the traction control allows high slip on the rear wheel.

7.22.17 MTC

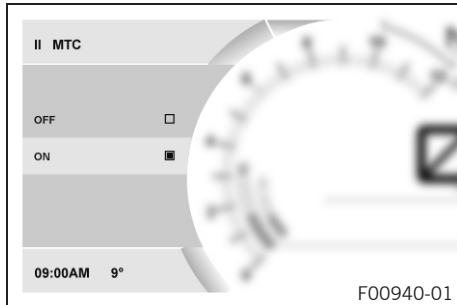

Condition

- The motorcycle is stationary.
- Press the **SET** button when the menu is closed.
- Press the **UP** or **DOWN** button until **Motorcycle** is marked. Press the **SET** button to open the menu.
- Press the **UP** or **DOWN** button until **MTC** is marked. Press the **SET** button to open the menu.
- Activate the menu item using the **UP** or **DOWN** button.
- Switch the **MTC** on or off by pressing the **SET** button.



Info

After the ignition is switched on, the motorcycle traction control is reactivated.

Press and hold the **SET** button for 3-5 seconds.

Activation of motorcycle traction control.

7.22.18 MTC+MSR (optional)

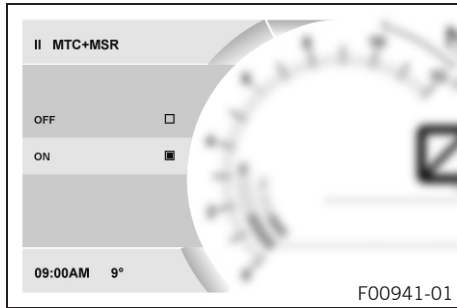

Condition

- The motorcycle is stationary.
- Press the **SET** button when the menu is closed.
- Press the **UP** or **DOWN** button until **Motorcycle** is marked. Press the **SET** button to open the menu.
- Press the **UP** or **DOWN** button until **MTC+MSR** is marked. Press the **SET** button to open the menu.
- Activate the menu item using the **UP** or **DOWN** button.
- Switch the **MTC+MSR** on or off by pressing the **SET** button.

Info

When the ABS or active Drive Mode **Offroad** is switched off, the **MSR** is not active.
After the ignition is switched on, motorcycle traction control and engine braking control are enabled again.

Press and hold the **SET** button for 3-5 seconds.

Activation of motorcycle traction control and engine braking control.

7.22.19 ABS

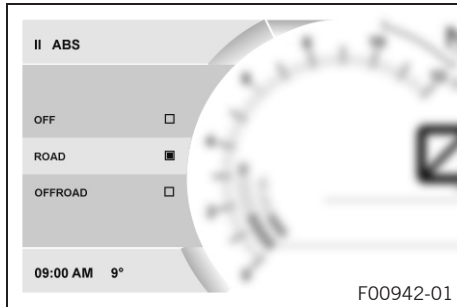

Condition

- The motorcycle is stationary.
- Press the **SET** button when the menu is closed.
- Press the **UP** or **DOWN** button until **Motorcycle** is marked. Press the **SET** button to open the menu.



Warning

Voiding of the government approval for road use and the insurance coverage If the ABS is switched off completely, the vehicle's approval for road use is invalidated.

- Only operate the vehicle in closed-off areas remote from public road traffic if the ABS is switched off completely.
-
- Press the **UP** or **DOWN** button until **ABS** is marked. Press the **SET** button to open the menu.
 - Activate the menu item using the **UP** or **DOWN** button.
 - Press the **ABS** button to switch off **SET** or to select between ABS modes.



Info

The ABS can only be reactivated by switching on the ignition again.

When the **Road** ABS mode is enabled, ABS controls both wheels.

When the **Offroad** ABS mode is enabled, ABS only controls the front wheel. The rear wheel is not controlled by ABS and may lock during braking maneuvers.

Press and hold the **SET** button for 3-5 seconds.

Activation of the different ABS modes.

7.22.20 HHC (optional)

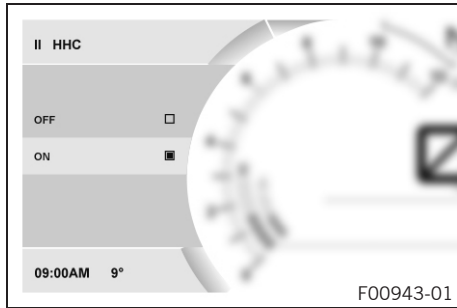

Condition

- The motorcycle is stationary.
- Press the **SET** button when the menu is closed.
- Press the **UP** or **DOWN** button until **Motorcycle** is marked. Press the **SET** button to open the menu.
- Press the **UP** or **DOWN** button until **HHC** is marked. Press the **SET** button to open the menu.
- Activate the menu item using the **UP** or **DOWN** button.
- Switch the **HHC** on or off by pressing the **SET** button.

7.22.21 Favourites

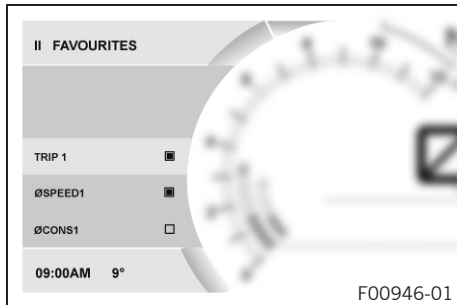

Condition

- The motorcycle is stationary.
- Press the **SET** button when the menu is closed.
- Press the **UP** or **DOWN** button until **Settings** is marked. Press the **SET** button to open the menu.
- Press the **UP** or **DOWN** button until **Favourites** is marked. Press the **SET** button to open the menu.
- Press the **UP** or **DOWN** button to activate the menu item and select it with the **SET** button.

Up to eight items of information can be selected in the **Favourites** menu.

7.22.22 Quick Selector 1

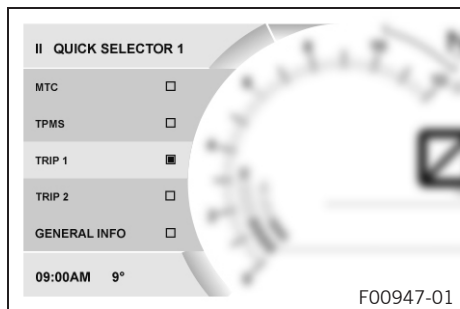

Condition

- The motorcycle is stationary.
- Press the **SET** button when the menu is closed.
- Press the **UP** or **DOWN** button until **Settings** is marked. Press the **SET** button to open the menu.
- Press the **UP** or **DOWN** button until **Quick Selector 1** is marked. Press the **SET** button to open the menu.
- Press the **UP** or **DOWN** button to activate the menu item and select it with the **SET** button.

Information can be selected in the **Quick Selector 1** menu.

When the menu is closed, the **Quick Selector 1** menu is opened by pressing the **UP** button.

7.22.23 Quick Selector 2

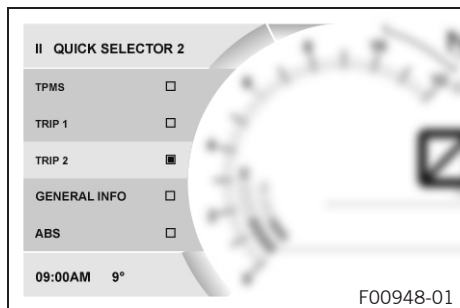

Condition

- The motorcycle is stationary.
- Press the **SET** button when the menu is closed.
- Press the **UP** or **DOWN** button until **Settings** is marked. Press the **SET** button to open the menu.
- Press the **UP** or **DOWN** button until **Quick Selector 2** is marked. Press the **SET** button to open the menu.
- Press the **UP** or **DOWN** button to activate the menu item and select it with the **SET** button.

Information can be selected in the **Quick Selector 2** menu.

When the menu is closed, the **Quick Selector 2** menu is opened by pressing the **DOWN** button.

7.22.24 Distance

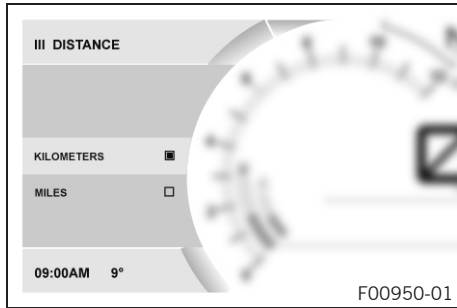

Condition

- The motorcycle is stationary.
- Press the **SET** button when the menu is closed.
- Press the **UP** or **DOWN** button until **Preferences** is marked. Press the **SET** button to open the menu.
- Press the **UP** or **DOWN** button until **Units** is marked.
- Press the **SET** button to open the menu.
- Press the **UP** or **DOWN** button until **Distance** is marked. Press the **SET** button to open the menu.
- Activate the menu item using the **UP** or **DOWN** button.
- Press the **SET** button to confirm the desired unit.

7.22.25 Temp

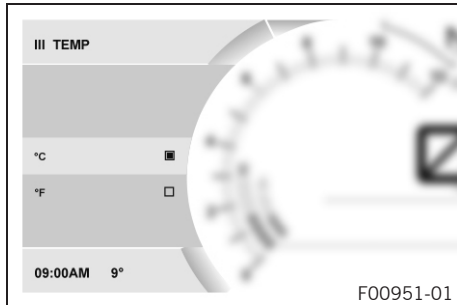

Condition

- The motorcycle is stationary.
- Press the **SET** button when the menu is closed.
- Press the **UP** or **DOWN** button until **Preferences** is marked. Press the **SET** button to open the menu.
- Press the **UP** or **DOWN** button until **Units** is marked.
- Press the **SET** button to open the menu.
- Press the **UP** or **DOWN** button until **Temp** is marked. Press the **SET** button to open the menu.
- Activate the menu item using the **UP** or **DOWN** button.
- Press the **SET** button to confirm the desired unit.

7.22.26 Pressure

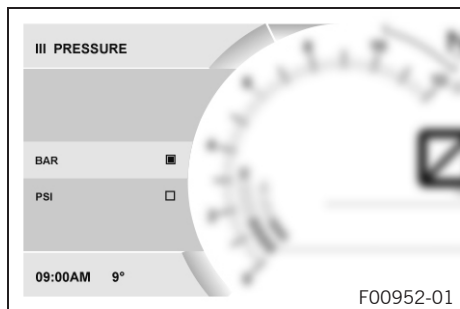

Condition

- The motorcycle is stationary.
- Press the **SET** button when the menu is closed.
- Press the **UP** or **DOWN** button until **Preferences** is marked. Press the **SET** button to open the menu.
- Press the **UP** or **DOWN** button until **Units** is marked.
- Press the **SET** button to open the menu.
- Press the **UP** or **DOWN** button until **Pressure** is marked. Press the **SET** button to open the menu.
- Activate the menu item using the **UP** or **DOWN** button.
- Press the **SET** button to confirm the desired unit.

7.22.27 Consumption

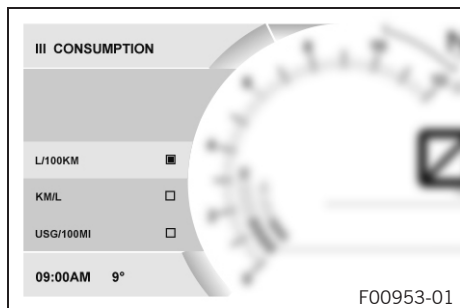

Condition

- The motorcycle is stationary.
- Press the **SET** button when the menu is closed.
- Press the **UP** or **DOWN** button until **Preferences** is marked. Press the **SET** button to open the menu.
- Press the **UP** or **DOWN** button until **Units** is marked.
- Press the **SET** button to open the menu.
- Press the **UP** or **DOWN** button until **Consumption** is marked. Press the **SET** button to open the menu.
- Activate the menu item using the **UP** or **DOWN** button.
- Press the **SET** button to confirm the desired unit.

7.22.28 Language

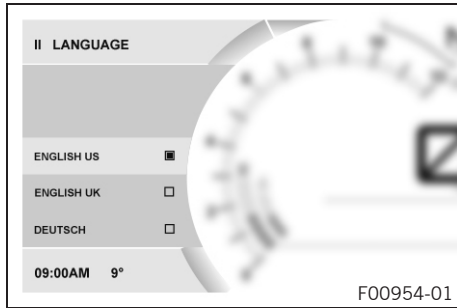

Condition

- The motorcycle is stationary.
- Press the **SET** button when the menu is closed.
- Press the **UP** or **DOWN** button until **Preferences** is marked. Press the **SET** button to open the menu.
- Press the **UP** or **DOWN** button until **Language** is marked. Press the **SET** button to open the menu.
- Press the **UP** or **DOWN** button to activate the menu item and select it with the **SET** button.

The menu languages are US English, UK English, German, Italian, French, and Spanish.

7.22.29 Shift Light

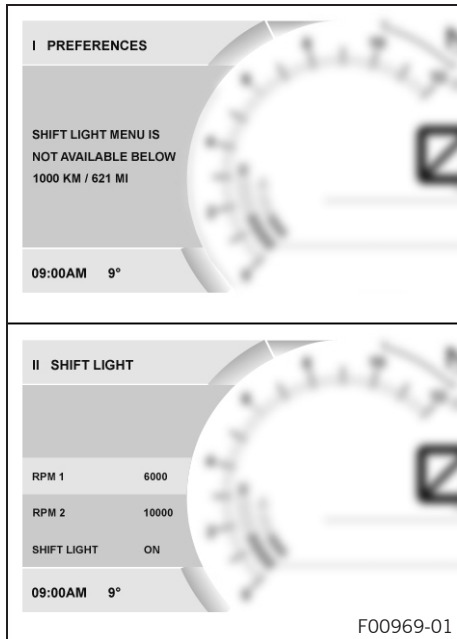

Condition

- The motorcycle is stationary.
- **ODO** > 1000 km (621 mi).
- Press the **SET** button when the menu is closed.
- Press the **UP** or **DOWN** button until **Preferences** is marked. Press the **SET** button to open the menu.
- Press the **UP** or **DOWN** button until **Shift Light** is marked. Press the **SET** button to open the menu.
- Activate the menu item using the **UP** or **DOWN** button.
- Press the **SET** button to switch the shift warning light on or off and to adjust the engine speed for the gear shift recommendation.



Info

When the engine speed reaches **RPM 1**, the speed display lights up red.
When the engine speed reaches **RPM 2**, the speed display flashes red.

7.22.30 Setting the time and date

Condition

The motorcycle is stationary.

7 COMBINATION INSTRUMENT

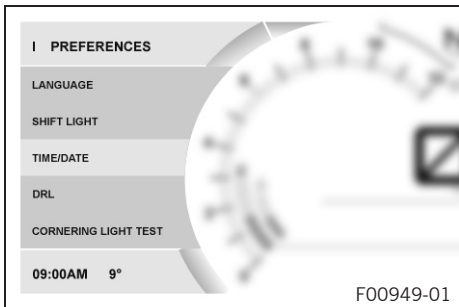

- Press the **SET** button when the menu is closed.
- Press the **UP** or **DOWN** button until **Preferences** appears. Press the **SET** button to open the menu.
- Press the **UP** or **DOWN** button until **Time/Date** is marked. Press the **SET** button to open the menu.

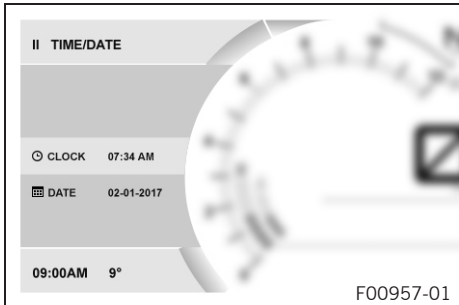

Setting the clock

- Press the **UP** or **DOWN** button until the time is marked.
- Press the **SET** button.
 - ✓ The hour next to **"Clock"** flashes.
- Press the **UP** or **DOWN** button until the current hour is set.
- Press the **SET** button.
 - ✓ The minute next to **"Clock"** flashes.
- Press the **UP** or **DOWN** button until the current minute is set.
- Press the **SET** button.
 - ✓ The time is stored.

7 COMBINATION INSTRUMENT

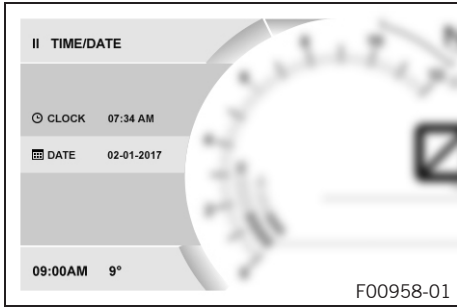

Setting the date

- Press the **UP** or **DOWN** button until the date is marked.
- Press the **SET** button.
 - ✓ The day next to "**Date**" flashes.
- Press the **UP** or **DOWN** button until the current day is set.
- Press the **SET** button.
 - ✓ The month next to "**Date**" flashes.
- Press the **UP** or **DOWN** button until the current month is set.
- Press the **SET** button.
 - ✓ The year next to "**Date**" flashes.
- Press the **UP** or **DOWN** button until the current year is set.
- Press the **SET** button.
 - ✓ The date is stored.

7.22.31 DRL

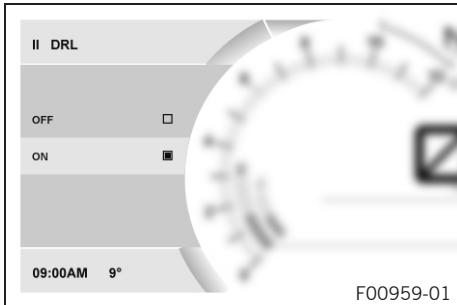

Condition

- The motorcycle is stationary.
- Press the **SET** button when the menu is closed.
- Press the **UP** or **DOWN** button until **Preferences** is marked. Press the **SET** button to open the menu.



Warning

Danger of accidents When visibility is poor, the daytime running light is not a substitute for the low beam.

Automatic switching between the daytime running light and low beam may only be partially available when visibility is significantly impaired due to fog, snow or rain.

- Ensure that the appropriate type of lighting is always selected.
 - If necessary switch off the daytime running lights using the menu before going on a ride or when stopped so that the low beam is switched on permanently.
 - Note the legal regulations regarding the daytime running light.
-
- Press the **UP** or **DOWN** button until **DRL** is marked. Press the **SET** button to open the menu.
 - Activate the menu item using the **UP** or **DOWN** button.
 - Press the **SET** button to switch the daytime running light on or off.

7.22.32 Quick Shift + (optional)

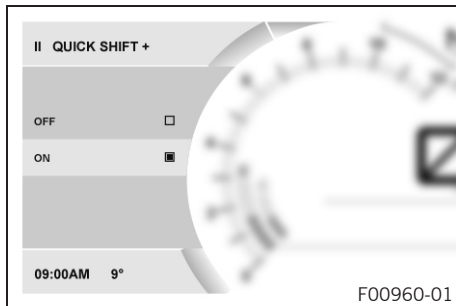

Condition

- The motorcycle is stationary.
- Press the **SET** button when the menu is closed.
- Press the **UP** or **DOWN** button until **Preferences** is marked. Press the **SET** button to open the menu.
- Press the **UP** or **DOWN** button until **Quick Shift +** is marked. Press the **SET** button to open the menu.
- Activate the menu item using the **UP** or **DOWN** button.
- Switch the **Quick Shift +** on or off by pressing the **SET** button.

7.22.33 Heated Grips (optional)

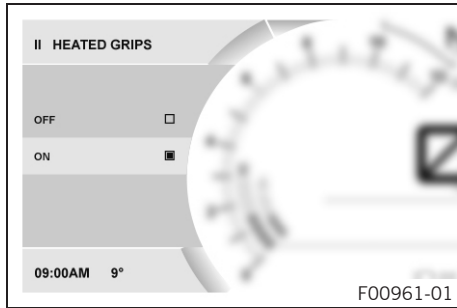

Condition

- The motorcycle is stationary.
- Press the **SET** button when the menu is closed.
- Press the **UP** or **DOWN** button until **Preferences** is marked. Press the **SET** button to open the menu.
- Press the **UP** or **DOWN** button until **Heated Grips** is marked. Press the **SET** button to open the menu.
- Activate the menu item using the **UP** or **DOWN** button.
- Switch the **Heated Grips** on or off by pressing the **SET** button.

7.22.34 Heated Seat Rid (optional)

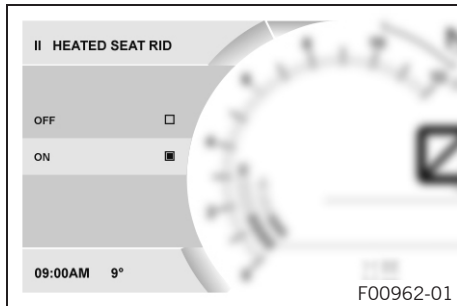

Condition

- The motorcycle is stationary.
- Press the **SET** button when the menu is closed.
- Press the **UP** or **DOWN** button until **Preferences** is marked. Press the **SET** button to open the menu.
- Press the **UP** or **DOWN** button until **Heated Seat Rid** is marked. Press the **SET** button to open the menu.
- Activate the menu item using the **UP** or **DOWN** button.
- Switch the **Heated Seat Rid** on or off by pressing the **SET** button.

7.22.35 Heated Seat Pas (optional)

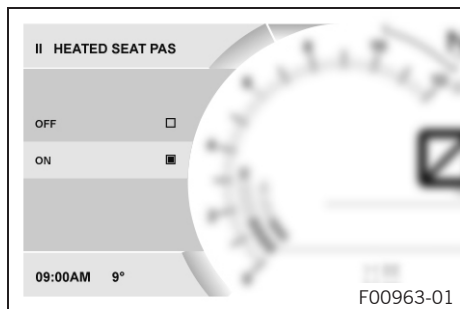

Condition

- The motorcycle is stationary.
- Press the **SET** button when the menu is closed.
- Press the **UP** or **DOWN** button until **Preferences** is marked. Press the **SET** button to open the menu.
- Press the **UP** or **DOWN** button until **Heated Seat Pas** is marked. Press the **SET** button to open the menu.
- Activate the menu item using the **UP** or **DOWN** button.
- Switch the **Heated Seat Pas** on or off by pressing the **SET** button.

7.22.36 Cornering Light Test

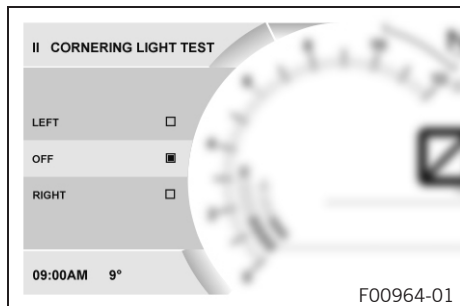

Condition

- The motorcycle is stationary.
- Press the **SET** button when the menu is closed.
- Press the **UP** or **DOWN** button until **Preferences** is marked. Press the **SET** button to open the menu.
- Press the **UP** or **DOWN** button until **Cornering Light Test** is marked. Press the **SET** button to open the menu.
- Activate the menu item using the **UP** or **DOWN** button.



Info

The **Cornering Light Test** is performed on the left cornering light in the **Left** sub-menu.

The **Cornering Light Test** is performed on the right cornering light in the **Right** sub-menu.

The **Cornering Light Test** is completed in the **Off** sub-menu.

- Press the **SET** button in order to perform or switch off the desired **Cornering Light Test**.



Info

The respective cornering light segments light up in succession, starting with the lower segment.
When the test of the respective cornering light is complete, the upper segment lights up continuously.

7.22.37 Service

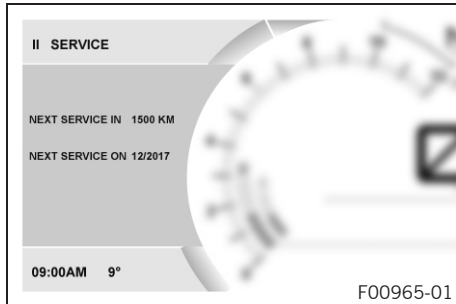

Condition

- The motorcycle is stationary.
- Press the **SET** button when the menu is closed.
- Press the **UP** or **DOWN** button until **Preferences** is marked. Press the **SET** button to open the menu.
- Press the **UP** or **DOWN** button until **Service** is marked. Press the **SET** button to open the menu.

The next service due is shown in the **Service** menu.

7.22.38 Extra Functions

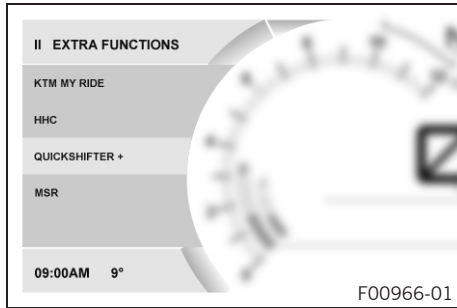

Condition

- The motorcycle is stationary.
- Motorcycle with optional supplementary function.
- Press the **SET** button when the menu is closed.
- Press the **UP** or **DOWN** button until **Preferences** is marked. Press the **SET** button to open the menu.
- Press the **UP** or **DOWN** button until **Extra Functions** is marked. Press the **SET** button to open the menu.
- Use the **UP** or **DOWN** button to navigate through the extra functions.

The optional extra functions are listed in **Extra Functions**.



Info

The current **KTM PowerParts** and the available software for your vehicle can be found on the KTM website.

24.1 EU declaration of conformity



Info

The functional and equipment scope is model-dependent and may not include all wireless systems referred to.

COBO SpA hereby declares that the **BT-ROUTER** wireless system conforms with the relevant guidelines. The full text of the EU Declaration of Conformity is available at the following Internet address.

Certification website: <http://www.ktm.com/btrouter>

KTM AG hereby declares that the **KTM RACE ON system** wireless system conforms with the relevant guideline. The full text of the EU Declaration of Conformity is available at the following Internet address.

Certification website: <http://www.ktm.com/ktm-race-on-system>

KTM AG hereby declares that the **LC8 DASHBOARD** wireless system conforms with the relevant guideline. The full text of the EU Declaration of Conformity is available at the following Internet address.

Certification website: <http://www.ktm.com/lc8-dashboard>

Schrader Electronics Ltd hereby declares that **Tyre Pressure Monitoring Sensor "BC5A4"** wireless system conforms with the relevant guideline. The full text of the EU Declaration of Conformity is available at the following Internet address.

Certification website: <http://www.ktm.com/tpms>

Schrader Electronics Ltd hereby declares that **Tyre Pressure Monitoring Sensor "RDC3"** wireless system conforms with the relevant guideline. The full text of the EU Declaration of Conformity is available at the following Internet address.

Certification website: <http://www.ktm.com/tpms>

24.2 FCC declaration of conformity



Info

The functional and equipment scope is model-dependent and may not include all wireless systems referred to.

24 DECLARATIONS OF CONFORMITY

BT-ROUTER

FCC ID: Z64-2564N

IC: 4511-2564N

KTM RACE ON system - Active Key

FCC ID: VFZKLGKZADIO1

IC: 22239-KLGKZADIO1

KTM RACE ON system - Main Unit

FCC ID: VFZKLGKZADIO1

IC: 22239-KLGMZADIO1

LC8 DASHBOARD

FCC ID: 2AKP9-LC8CLUSTER1

IC: 22273-LC8CLUSTER1

Tyre Pressure Monitoring Sensor "BC5A4"

FCC ID: MRXBC5A4

IC: 2546A-BC5A4

Tyre Pressure Monitoring Sensor "RDC3"

FCC ID: MRXRDC3

IC: 2546A-RDC3

Warning

This device complies with article 15 of the FCC regulations.

Operation is subject to the following two conditions:

- 1 This device must not cause harmful interference.
- 2 This device must be able to absorb any received interference, including interference that potentially causes undesirable operation.

This equipment has been tested and complies with the limits for Class B digital devices, in accordance with article 15 of the FCC regulations. These limits are designed to provide satisfactory protection against harmful interference in residential areas. Devices of this type generate and use as well as also transmit radio frequencies. Therefore, if they are not installed and operated in accordance with the instructions, they may cause harmful interference to radio reception. However, there is no guarantee that interference will not occur in certain cases of application. Should this device cause harmful interference to radio or television reception, (check this by switching the device on and off), you can potentially eliminate this interference as follows:

24 DECLARATIONS OF CONFORMITY

- Re-align the receiving antenna.
- Increase the separation between device and radio receiver.
- Connect the device and the radio receiver to separate electric circuits.
- Consult your dealer or a radio/TV technician.

Alterations and modifications not expressly approved by the relevant authority may result in the user being prohibited from operating the equipment.