FCC Test Report

Report No.: AGC06620160401FE08

FCC ID : 2AIEBTTS
APPLICATION PURPOSE : Original Equipment
PRODUCT DESIGNATION : Bluetooth intercom
BRAND NAME : EJEAS
MODEL NAME : TTS, TTS-4, TTS-8, TTS-10, TTS-15, TTS-20
CLIENT : Shenzhen Ejeas Technology Co., Ltd.
DATE OF ISSUE : May 16, 2016
STANDARD(S) : FCC Part 15 Rules
REPORT VERSION : V1.0

Attestation of Global Compliance (Shenzhen) Co., Ltd



CAUTION:

This report shall not be reproduced except in full without the written permission of the test laboratory and shall not be quoted out of context.



Report Revise Record

Report Version	Revise Time	Issued Date	Valid Version	Notes
V1.0	/	May 16, 2016	Valid	Original Report

TABLE OF CONTENTS

1. VERIFICATION OF COMPLIANCE	5
2. GENERAL INFORMATION	6
2.1 PRODUCT DESCRIPTION	6
2.2 RELATED SUBMITTAL(S)/GRANT(S).....	6
2.3 TEST METHODOLOGY	6
2.4 TEST FACILITY.....	6
2.5 SPECIAL ACCESSORIES.....	6
2.6 EQUIPMENT MODIFICATIONS.....	6
2.7 MEASUREMENT UNCERTAINTY	6
3. SYSTEM TEST CONFIGURATION	7
3.1 CONFIGURATION OF TESTED SYSTEM	7
3.2 EQUIPMENT USED IN TESTED SYSTEM	7
3.3. SUMMARY OF TEST RESULTS	8
4. DESCRIPTION OF TEST MODES	9
5. ANTENNA REQUIREMENT	10
5.1. STANDARD APPLICABLE	10
5.2. TEST RESULT	10
6. TEST FACILITY	11
7. RADIATED EMISSION	13
7.1 MEASUREMENT PROCEDURE	13
7.2 TEST SETUP.....	14
7.3 LIMITS AND MEASUREMENT RESULT	16
7.4 TEST RESULT (WORST MODULATION: GFSK)	16
8. BAND EDGE EMISSION	29
8.1. MEASUREMENT PROCEDURE.....	29
8.2. TEST SET-UP	29
8.3. TEST RESULT	30
9. 6DB BANDWIDTH	34
9.1. TEST PROCEDURE.....	34
9.2. SUMMARY OF TEST RESULTS/PLOTS	34
10. CONDUCTED OUTPUT POWER	36
10.1. MEASUREMENT PROCEDURE.....	36
10.2. TEST SET-UP (BLOCK DIAGRAM OF CONFIGURATION).....	36
10.3. LIMITS AND MEASUREMENT RESULT	37
11. MAXIMUM CONDUCTED OUTPUT POWER SPECTRAL DENSITY	39
11.1 MEASUREMENT PROCEDURE.....	39

11.2 TEST SET-UP (BLOCK DIAGRAM OF CONFIGURATION)..... 39

11.3 LIMITS AND MEASUREMENT RESULT 39

12. FCC LINE CONDUCTED EMISSION TEST 42

12.1 LIMITS 42

12.2 TEST SETUP 42

12.3 PRELIMINARY PROCEDURE 43

12.4 FINAL TEST PROCEDURE..... 43

12.5 TEST RESULT OF POWER LINE 44

APPENDIX A: PHOTOGRAPHS OF TEST SETUP 46

APPENDIX B: PHOTOGRAPHS OF EUT 48

1. VERIFICATION OF COMPLIANCE

Applicant	Shenzhen Ejeas Technology Co., Ltd.
Address	20A, Main Bldg., (Zhida Mansion) No. 8-11, Lane 2, Zone 9, Bantian Guangyayua Longgang Dist., Shenzhen, Guangdong, China
Manufacturer	Shenzhen Ejeas Technology Co., Ltd.
Address	20A, Main Bldg., (Zhida Mansion) No. 8-11, Lane 2, Zone 9, Bantian Guangyayua Longgang Dist., Shenzhen, Guangdong, China
Product Designation	Bluetooth intercom
Brand Name	EJEAS
Test Model	TTS
Series Model	TTS-4, TTS-8, TTS-10, TTS-15, TTS-20
Different Description	All the same except for the model name
Date of test	Apr.11, 2016 to Apr.13, 2016
Deviation	None
Condition of Test Sample	Normal
Report Template	AGCRT-US-BLE/RF (2013-03-01)

We hereby certify that:

The above equipment was tested by Dongguan Precise Testing Service Co., Ltd. The test data, the energy emitted by the sample tested as described in this report is in compliance with the requirements of FCC Rules Part 15.247.



Tested By _____
Time Huang(Huang Nanhui) May 16, 2016



Reviewed By _____
Forrest Lei(Lei Yonggang) May 16, 2016



Approved By _____
Solger Zhang(Zhang Hongyi)
Authorized Officer May 16, 2016

2.GENERAL INFORMATION

2.1PRODUCT DESCRIPTION

The EUT is designed as a “Bluetooth intercom”. It is designed by way of utilizing the FHSS technology to achieve the system operation.

A major technical description of EUT is described as following

Operation Frequency	2.402 GHz to 2.480GHz
Bluetooth Version	V4.1(BLE)
Modulation	GFSK
Number of channels	40 Channel(37 Hopping Channel,3 advertising Channel)
Antenna Designation	Wire Antenna
Antenna Gain	0dBi
Hardware Version	MODI-T8S_V2
Software Version	N/A
Power Supply	DC3.7V by Battery

Note: 1. The USB Port can not be used for communication with PC. It's only for charging.
2.The EUT support BLE function

2.2 RELATED SUBMITTAL(S)/GRANT(S)

This submittal(s) (test report) is intended for **FCC ID: 2AIEBTTS** filing to comply with Section 15.247of the FCC Part 15, Subpart C Rules.

2.3TEST METHODOLOGY

All measurements contained in this report were conducted with ANSI C63.10-2013.

2.4 TEST FACILITY

All measurement facilities used to collect the measurement data are located at Dongguan Precise Testing Service Co., Ltd.

Building D,Baoding Technology Park,Guangming Road2,Dongcheng District, Dongguan, Guangdong, China
FCC register No.:371540

2.5 SPECIAL ACCESSORIES

Refer to section 3.2.

2.6 EQUIPMENT MODIFICATIONS

Not available for this EUT intended for grant.

2.7 MEASUREMENT UNCERTAINTY

Radiation Emission:+/-3.2

Conduction Emission:+/-2.5

3. SYSTEM TEST CONFIGURATION

3.1 CONFIGURATION OF TESTED SYSTEM

Configure 1: (Normal hopping)

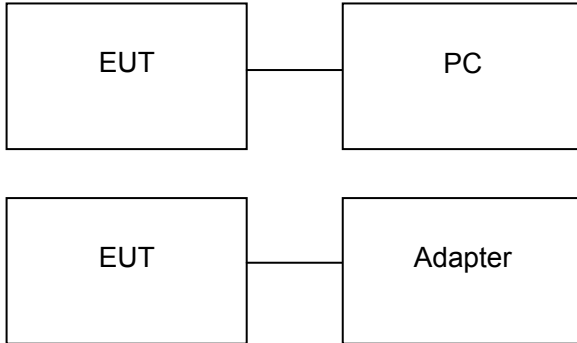

Configuration: Continuous TX

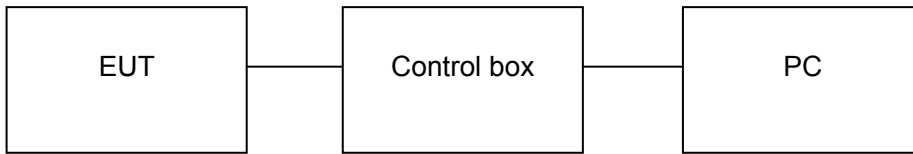

3.2 EQUIPMENT USED IN TESTED SYSTEM

Item	Equipment	Mfr/Brand	Model/Type No.	Remark
1	Bluetooth intercom	EJEAS	TTS	EUT
2	PC	Sony	E1412AYCW	A.E
3	Control box	CSR	CSR8670CGK524BN	A.E
4	Adapter	ETPCA	ETPCA-050100U3W	A.E

3.3. SUMMARY OF TEST RESULTS

FCC RULES	DESCRIPTION OF TEST	RESULT
§15.203	Antenna Requirement	Compliant
§15.209 §15.247(d)	Radiated Emission	Compliant
§15.247(d)	Band Edges	Compliant
§15.247	6 dB Bandwidth	Compliant
§15.247(b)	Conducted Power	Compliant
§15.247(e)	Maximum Conducted Output Power SPECTRAL Density	Compliant
§15.207	Line Conduction Emission	Compliant

4. DESCRIPTION OF TEST MODES

The EUT has been operated in one modulation: GFSK .

NO.	TEST MODE DESCRIPTION
1	Low channel GFSK
2	Middle channel GFSK
3	High channel GFSK
4	BT Link with charging
5	BT Link

Note:

1. Only the result of the worst case was recorded in the report if no any records.
2. For Radiated Emission, 3axis were chosen for testing for each applicable mode.
3. Transmitting duty cycle >98%, The average correction factor is about -0.18
4. The EUT used fully-charged battery when tested.

5. ANTENNA REQUIREMENT

5.1. STANDARD APPLICABLE

According to FCC 15.203, An intentional radiator shall be designed to ensure that no antenna other than that furnished by the responsible party shall be used with the device. The use of a permanently attached antenna or of an antenna that uses a unique coupling to the intentional radiator shall be considered sufficient to comply with the provisions of this Section. The manufacturer may design the unit so that a broken antenna can be replaced by the user, but the use of a standard antenna jack or electrical connector is prohibited. This requirement does not apply to carrier current devices or to devices operated under the provisions of Sections 15.211, 15.213, 15.217, 15.219, or 15.221. Further, this requirement does not apply to intentional radiators that must be professionally installed, such as perimeter protection systems and some field disturbance sensors, or to other intentional radiators which, in accordance with Section 15.31(d), must be measured at the installation site. However, the installer shall be responsible for ensuring that the proper antenna is employed so that the limits in this Part are not exceeded.

5.2. TEST RESULT

This product has a permanent antenna, fulfill the requirement of this section.

6. TEST FACILITY

Site	Dongguan Precise Testing Service Co., Ltd.
Location	Building D,Baoding Technology Park,Guangming Road2,Dongcheng District, Dongguan, Guangdong, China
FCC Registration No.	371540
Description	The test site is constructed and calibrated to meet the FCC requirements in documents ANSI C63.10:2013.

ALL TEST EQUIPMENT LIST

FOR RADIATED EMISSION TEST (BELOW 1GHZ)

Radiated Emission Test Site					
Name of Equipment	Manufacturer	Model Number	Serial Number	Last Calibration	Due Calibration
EMI Test Receiver	Rohde & Schwarz	ESCI	101417	July 4, 2015	July 3, 2016
Trilog Broadband Antenna (25M-1GHz)	SCHWARZBECK	VULB9160	9160-3355	July 4, 2015	July 3, 2016
Signal Amplifier	SCHWARZBECK	BBV 9475	9745-0013	July 4, 2015	July 3, 2016
RF Cable	SCHWARZBECK	AK9515E	96221	July 4, 2015	July 3, 2016
3m Anechoic Chamber	CHENGYU	966	PTS-001	June 6, 2015	June 5, 2016
MULTI-DEVICE Positioning Controller	Max-Full	MF-7802	MF780208339	N/A	N/A
Active loop antenna (9K-30MHz)	Schwarzbeck	FMZB1519	1519-038	June 6, 2015	June 5, 2016
Spectrum analyzer	Agilent	E4407B	MY46185649	June 6, 2015	June 5, 2016

FOR RADIATED EMISSION TEST (1GHZ ABOVE)

Radiated Emission Test Site					
Name of Equipment	Manufacturer	Model Number	Serial Number	Last Calibration	Due Calibration
EMI Test Receiver	Rohde & Schwarz	ESCI	101417	July 4, 2015	July 3, 2016
Horn Antenna (1G-18GHz)	SCHWARZBECK	BBHA9120D	9120D-1246	July 11, 2015	July 10, 2016
Spectrum Analyzer	Agilent	E4411B	MY4511453	July 4, 2015	July 3, 2016
Signal Amplifier	SCHWARZBECK	BBV 9718	9718-269	July 7, 2015	July 6, 2016
RF Cable	SCHWARZBECK	AK9515H	96220	July 8, 2015	July 7, 2016
3m Anechoic Chamber	CHENGYU	966	PTS-001	June 6, 2015	June 5, 2016
MULTI-DEVICE Positioning Controller	Max-Full	MF-7802	MF780208339	N/A	N/A
Horn Ant (18G-40GHz)	Schwarzbeck	BBHA 9170	9170-181	June 6, 2015	June 5, 2016

Conducted Emission Test Site					
Name of Equipment	Manufacturer	Model Number	Serial Number	Last Calibration	Due Calibration
EMI Test Receiver	- Rohde & Schwarz	ESCI	101417	July 4, 2015	July 3, 2016
Artificial Mains Network	Narda	L2-16B	000WX31025	July 8, 2015	July 7, 2016
Artificial Mains Network (AUX)	Narda	L2-16B	000WX31026	July 8, 2015	July 7, 2016
RF Cable	SCHWARZBECK	AK9515E	96222	July 4, 2015	July 3, 2016
Shielded Room	CHENGYU	843	PTS-002	June 6,2015	June 5,2016

7. RADIATED EMISSION

7.1 MEASUREMENT PROCEDURE

1. The measuring distance of 3m shall be used for measurements. The EUT was placed on the top of a rotating table 0.8 meter above the ground at a 3 meter semi-anechoic chamber. The table was rotated 360 degrees to determine the position of the highest radiation(below 1GHz)
2. The measuring distance of 3m shall used for measurements. The EUT was placed on the top of a rotating table 1.5 meter above the ground at a 3 meter semi-anechoic chamber. The table was rotated 360 degrees to determine the position of the highest radiation(above 1GHz)
3. The height of the test antenna shall vary between 1m to 4m.Both horizontal and vertical polarization Of the antenna are set to make the measurement.
4. The initial step in collecting radiated emission data is a receive peak detector mode. Pre-scanning the measurement frequency range. Significant peaks are then marked and then Quasi Peak detector mode re-measured.
5. All readings are peak unless otherwise stated QP in column of Note. Peak denoted that the Peak reading compliance with the QP limits and then QP Mode measurement didn't perform(Bleow 1GHz)
6. All readings are Peak mode value unless otherwise stated AVG in column of Note. If the Peak mode measured value compliance with the Peak limits and lower than AVG Limits, the EUT shall be deemed to meet Peak&AVG limits and then only Peak mode was measured, but AVG mode didn't perform.(above 1GHz)

7.2 TEST SETUP

Radiated Emission Test-Setup Frequency Below 30MHz

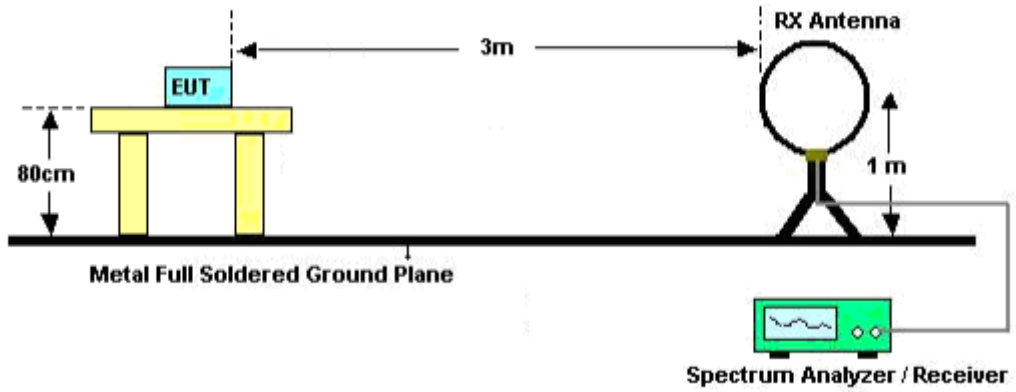

RADIATED EMISSION TEST SETUP 30MHz-1000MHz

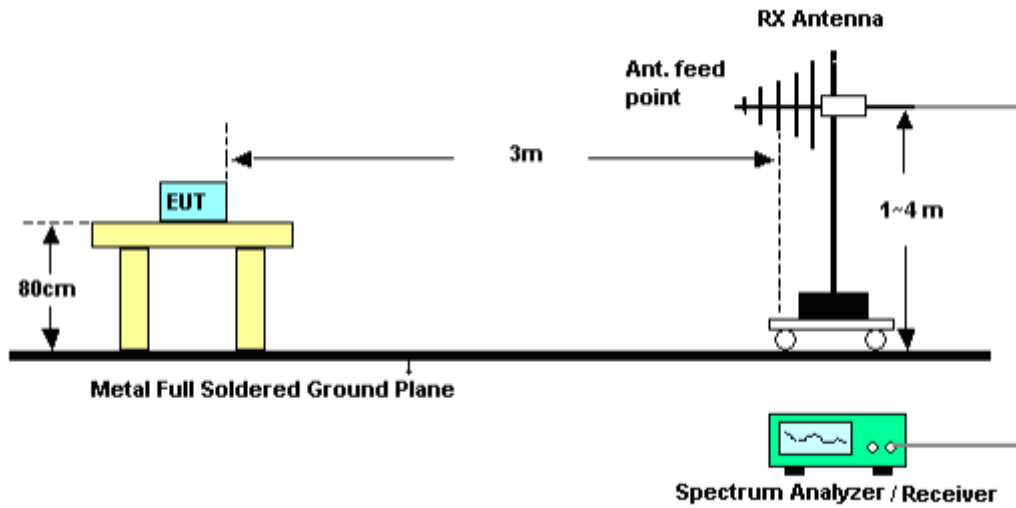

RADIATED EMISSION TEST SETUP ABOVE 1000MHz

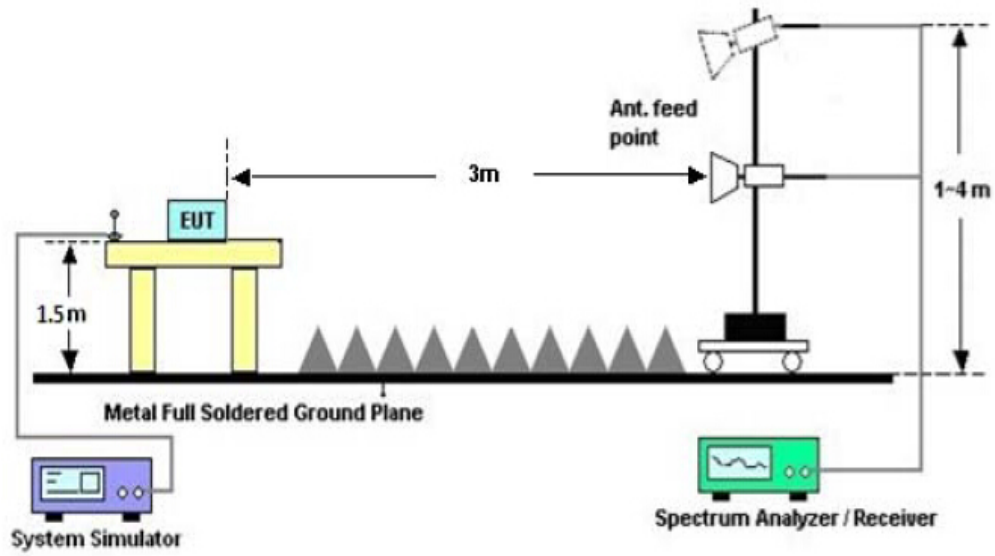

7.3 LIMITS AND MEASUREMENT RESULT

15.209 Limit in the below table has to be followed

Frequencies (MHz)	Field Strength (micorvolts/meter)	Measurement Distance (meters)
0.009~0.490	2400/F(KHz)	300
0.490~1.705	24000/F(KHz)	30
1.705~30.0	30	30
30~88	100	3
88~216	150	3
216~960	200	3
Above 960	500	3

Note: All modes were tested For restricted band radiated emission,
the test records reported below are the worst result compared to other modes.

7.4 TEST RESULT (Worst Modulation: GFSK)

RADIATED EMISSION BELOW 30MHZ

No emission found between lowest internal used/generated frequencies to 30MHz.

RADIATED EMISSION BELOW 1GHZ

RADIATED EMISSION TEST- (30MHZ-1GHZ)-LOW CHANNEL-HORIZONTAL

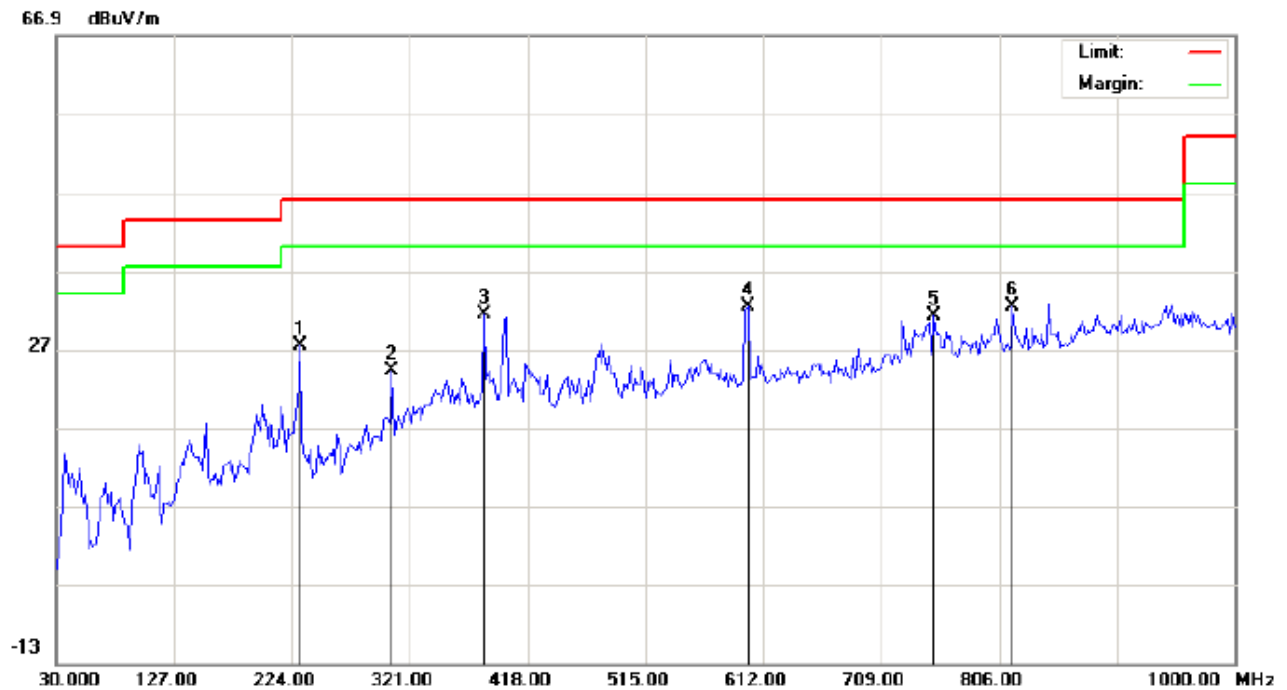

Site: site #1
 Limit: FCC Class B 3M Radiation
 EUT: Bluetooth intercom
 M/N: TTS
 Mode: Low Channel TX
 Note:

Polarization: *Horizontal*
 Power:
 Distance:

Temperature: 22.2
 Humidity: 51.6 %

No.	Mk	Freq.	Reading	Factor	Measurement	Limit	Over	Detector	Antenna Height	Table Degree	Comment
		MHz	dBuV	dB/m	dBuV/m	dBuV/m	dB		cm	degree	
1		230.4667	18.50	8.89	27.39	46.00	-18.61	peak			
2		306.4500	8.36	15.84	24.20	46.00	-21.80	peak			
3		382.4333	12.46	18.95	31.41	46.00	-14.59	peak			
4		599.0667	8.62	23.71	32.33	46.00	-13.67	peak			
5		752.6500	4.63	26.67	31.30	46.00	-14.70	peak			
6	*	817.3167	5.14	27.32	32.46	46.00	-13.54	peak			

RESULT: PASS

RADIATED EMISSION TEST- (30MHZ-1GHZ)-LOW CHANNEL -VERTICAL

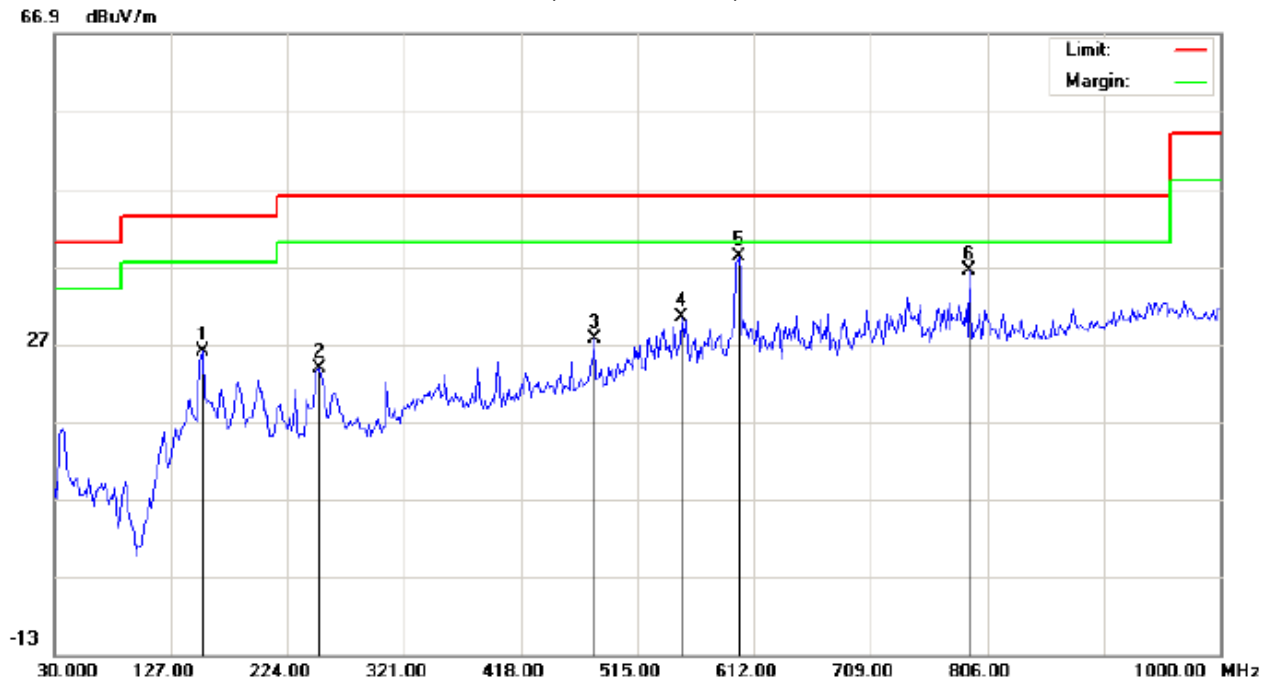

Site: site #1
Limit: FCC Class B 3M Radiation
EUT: Bluetooth intercom
M/N: TTS
Mode: Low Channel TX
Note:

Polarization: *Vertical*
Power:
Distance:

Temperature: 22.2
Humidity: 51.6 %

No.	Mk	Freq.	Reading	Factor	Measurement	Limit	Over	Detector	Antenna Height	Table Degree	Comment
		MHz	dBuV	dB/m	dBuV/m	dBuV/m	dB		cm	degree	
1		152.8667	10.69	15.28	25.97	43.50	-17.53	peak			
2		249.8667	9.93	13.89	23.82	46.00	-22.18	peak			
3		479.4333	6.75	20.91	27.66	46.00	-18.34	peak			
4		552.1833	7.95	22.49	30.44	46.00	-15.56	peak			
5	*	599.0667	15.38	22.73	38.11	46.00	-7.89	peak			
6		791.4500	9.14	27.20	36.34	46.00	-9.66	peak			

RESULT: PASS

- Note:** 1. Factor=Antenna Factor + Cable loss, Margin=Measurement-Limit.
2. The "Factor" value can be calculated automatically by software of measurement system.

RADIATED EMISSION TEST- (30MHZ-1GHZ)-MIDDLE CHANNEL-HORIZONTAL

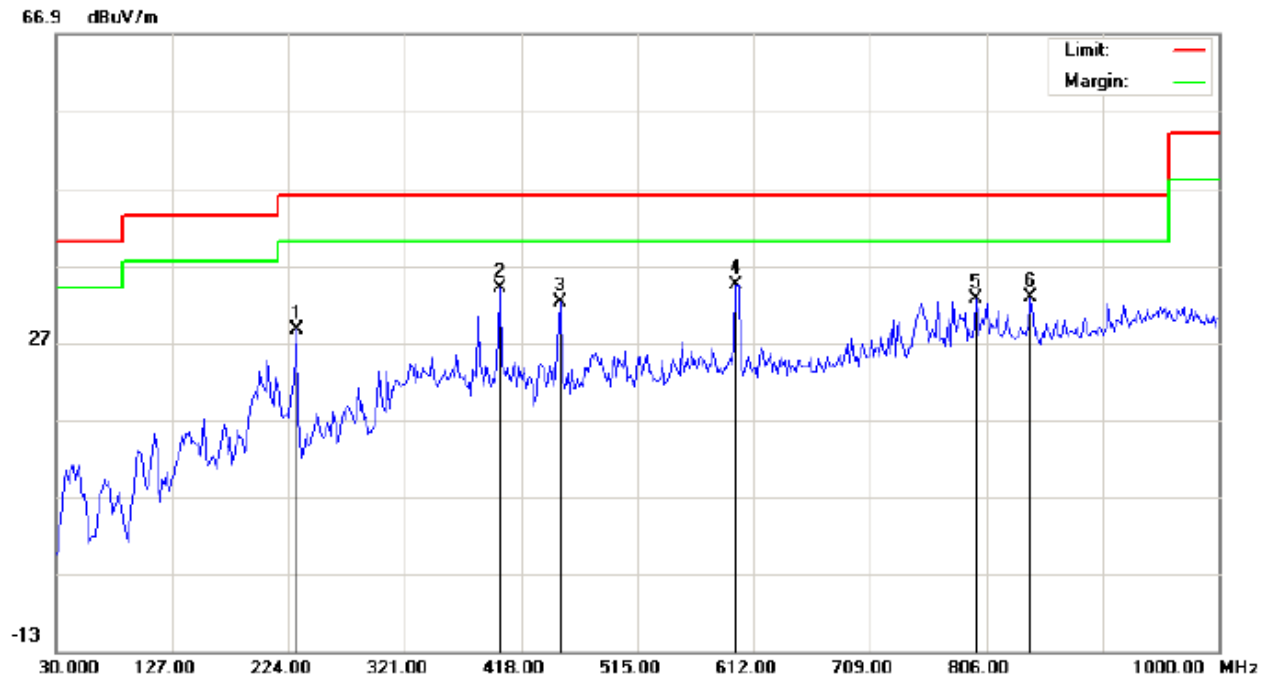

Site: site #1
Limit: FCC Class B 3M Radiation
EUT: Bluetooth intercom
M/N: TTS
Mode: Middle Channel TX
Note:

Polarization: *Horizontal*
Power:
Distance:

Temperature: 22.2
Humidity: 51.6 %

No.	Mk	Freq.	Reading	Factor	Measurement	Limit	Over	Detector	Antenna Height	Table Degree	Comment
		MHz	dBuV	dB/m	dBuV/m	dBuV/m	dB		cm	degree	
1		230.4667	19.77	8.89	28.66	46.00	-17.34	peak			
2		400.2167	14.88	19.08	33.96	46.00	-12.04	peak			
3		450.3333	11.63	20.59	32.22	46.00	-13.78	peak			
4	*	597.4500	10.81	23.67	34.48	46.00	-11.52	peak			
5		797.9167	5.39	27.29	32.68	46.00	-13.32	peak			
6		843.1833	5.46	27.31	32.77	46.00	-13.23	peak			

RESULT: PASS

RADIATED EMISSION TEST- (30MHZ-1GHZ)- MIDDLE CHANNEL -VERTICAL

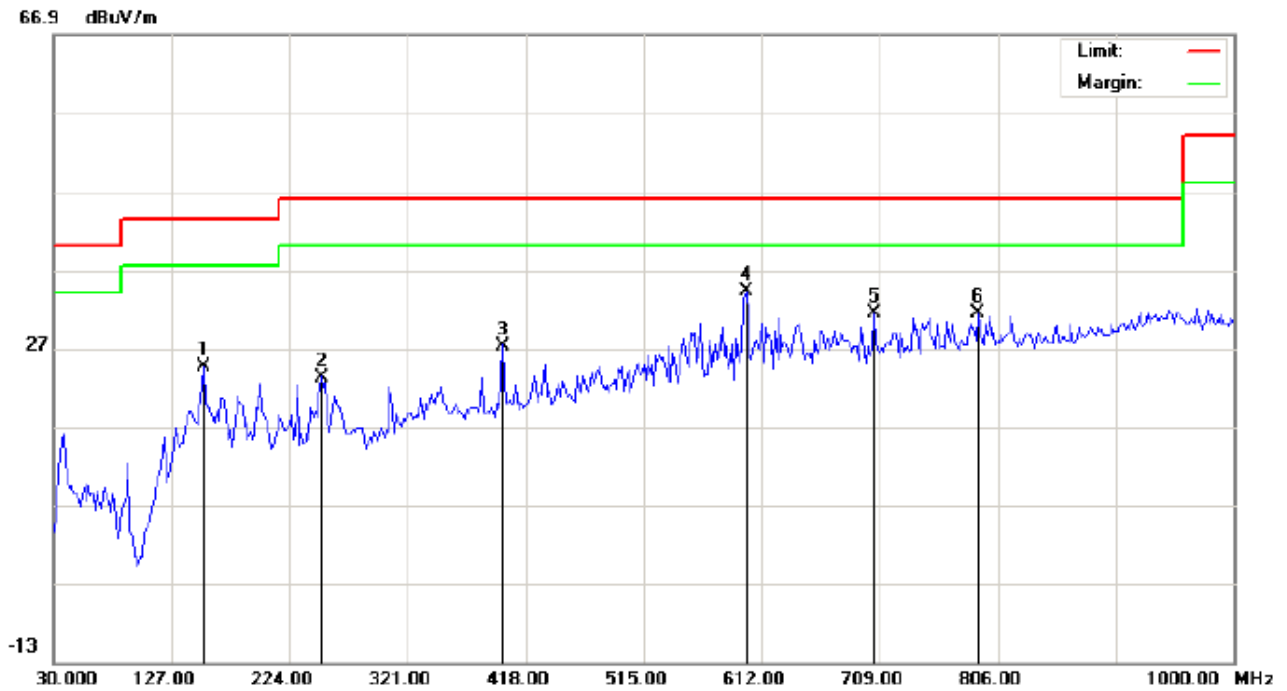

Site: site #1
 Limit: FCC Class B 3M Radiation
 EUT: Bluetooth intercom
 M/N: TTS
 Mode: Middle Channel TX
 Note:

Polarization: *Vertical*
 Power:
 Distance:

Temperature: 22.2
 Humidity: 51.6 %

No.	Mk	Freq.	Reading	Factor	Measurement	Limit	Over	Detector	Antenna Height	Table Degree	Comment
		MHz	dBuV	dB/m	dBuV/m	dBuV/m	dB		cm	degree	
1		152.8667	9.24	15.28	24.52	43.50	-18.98	peak			
2		249.8667	9.41	13.89	23.30	46.00	-22.70	peak			
3		398.6000	8.24	19.06	27.30	46.00	-18.70	peak			
4	*	599.0667	11.48	22.73	34.21	46.00	-11.79	peak			
5		704.1500	6.08	25.31	31.39	46.00	-14.61	peak			
6		789.8333	4.13	27.18	31.31	46.00	-14.69	peak			

RESULT: PASS

Note: 1. Factor=Antenna Factor + Cable loss, Margin=Measurement-Limit.
 2. The "Factor" value can be calculated automatically by software of measurement system.

RADIATED EMISSION TEST- (30MHZ-1GHZ)-HIGH CHANNEL-HORIZONTAL

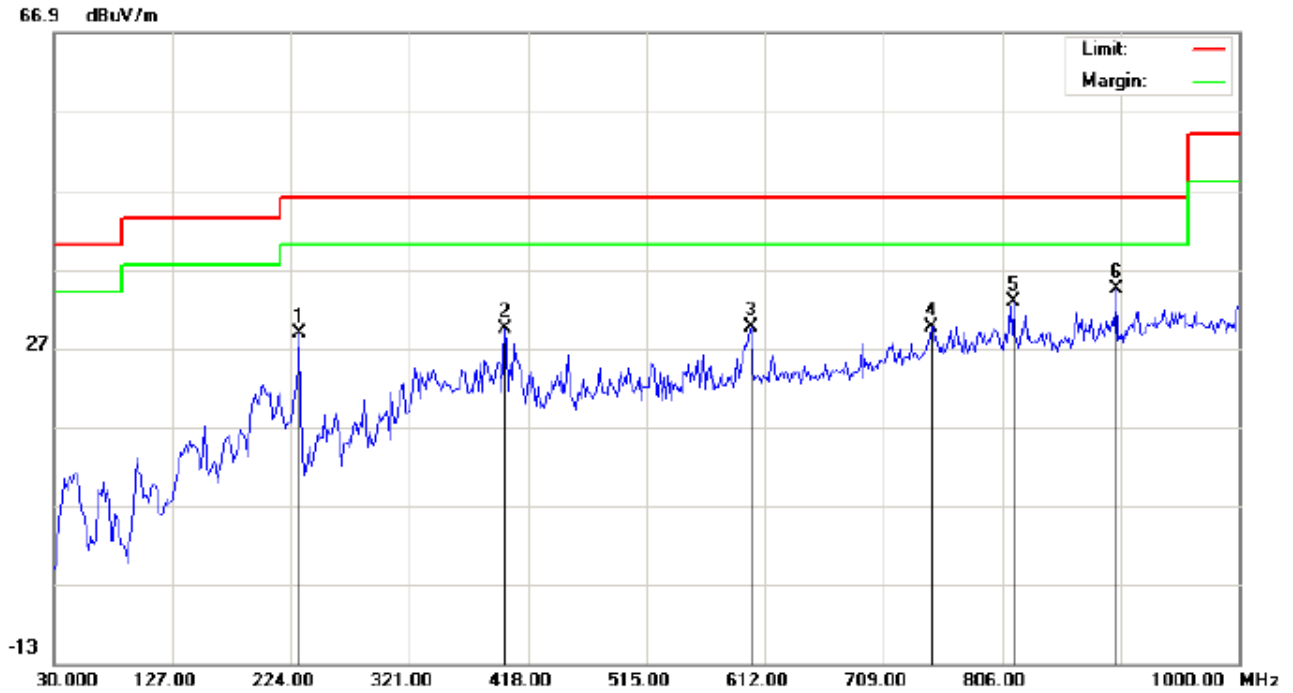

Site: site #1
Limit: FCC Class B 3M Radiation
EUT: Bluetooth intercom
M/N: TTS
Mode: High Channel TX
Note:

Polarization: *Horizontal*
Power:
Distance:

Temperature: 22.2
Humidity: 51.6 %

No.	Mk	Freq.	Reading	Factor	Measurement	Limit	Over	Detector	Antenna Height	Table Degree	Comment
		MHz	dBuV	dB/m	dBuV/m	dBuV/m	dB		cm	degree	
1		230.4667	19.83	8.89	28.72	46.00	-17.28	peak			
2		398.6000	10.39	19.06	29.45	46.00	-16.55	peak			
3		600.6833	5.88	23.73	29.61	46.00	-16.39	peak			
4		747.8000	3.12	26.57	29.69	46.00	-16.31	peak			
5		815.7000	5.41	27.32	32.73	46.00	-13.27	peak			
6	*	899.7667	5.88	28.60	34.48	46.00	-11.52	peak			

RESULT: PASS

RADIATED EMISSION TEST- (30MHZ-1GHZ)-HIGH CHANNEL -VERTICAL

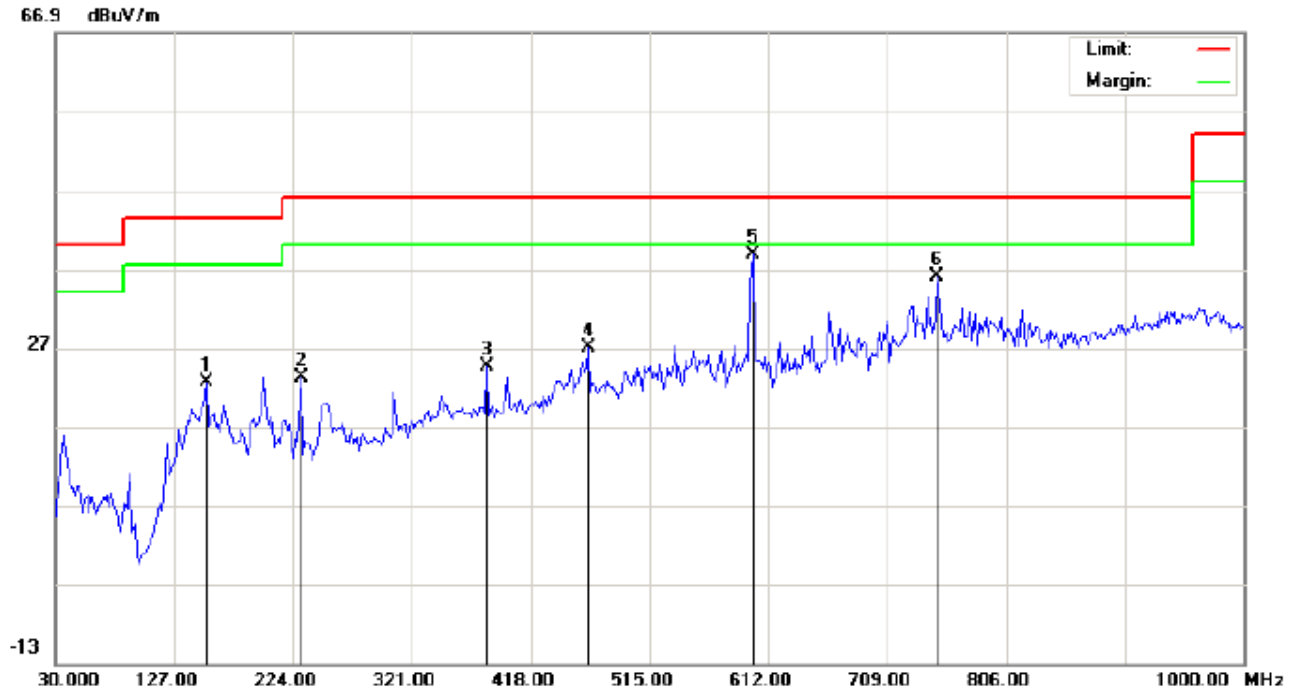

Site: site #1
Limit: FCC Class B 3M Radiation
EUT: Bluetooth intercom
M/N: TTS
Mode: High Channel TX
Note:

Polarization: *Vertical*
Power:
Distance:

Temperature: 22.2
Humidity: 51.6 %

No.	Mk	Freq.	Reading	Factor	Measurement	Limit	Over	Detector	Antenna Height	Table Degree	Comment
		MHz	dBuV	dB/m	dBuV/m	dBuV/m	dB		cm	degree	
1		152.8667	7.32	15.28	22.60	43.50	-20.90	peak			
2		230.4667	11.18	11.99	23.17	46.00	-22.83	peak			
3		382.4333	5.64	18.95	24.59	46.00	-21.41	peak			
4		464.8833	6.24	20.75	26.99	46.00	-19.01	peak			
5	*	599.0667	16.09	22.73	38.82	46.00	-7.18	peak			
6		749.4167	9.48	26.61	36.09	46.00	-9.91	peak			

RESULT: PASS

Note: 1. Factor=Antenna Factor + Cable loss, Margin=Measurement-Limit.

2. The "Factor" value can be calculated automatically by software of measurement system.

RADIATED EMISSION TEST-(ABOVE 1GHZ)-LOW CHANNEL-VERTICAL

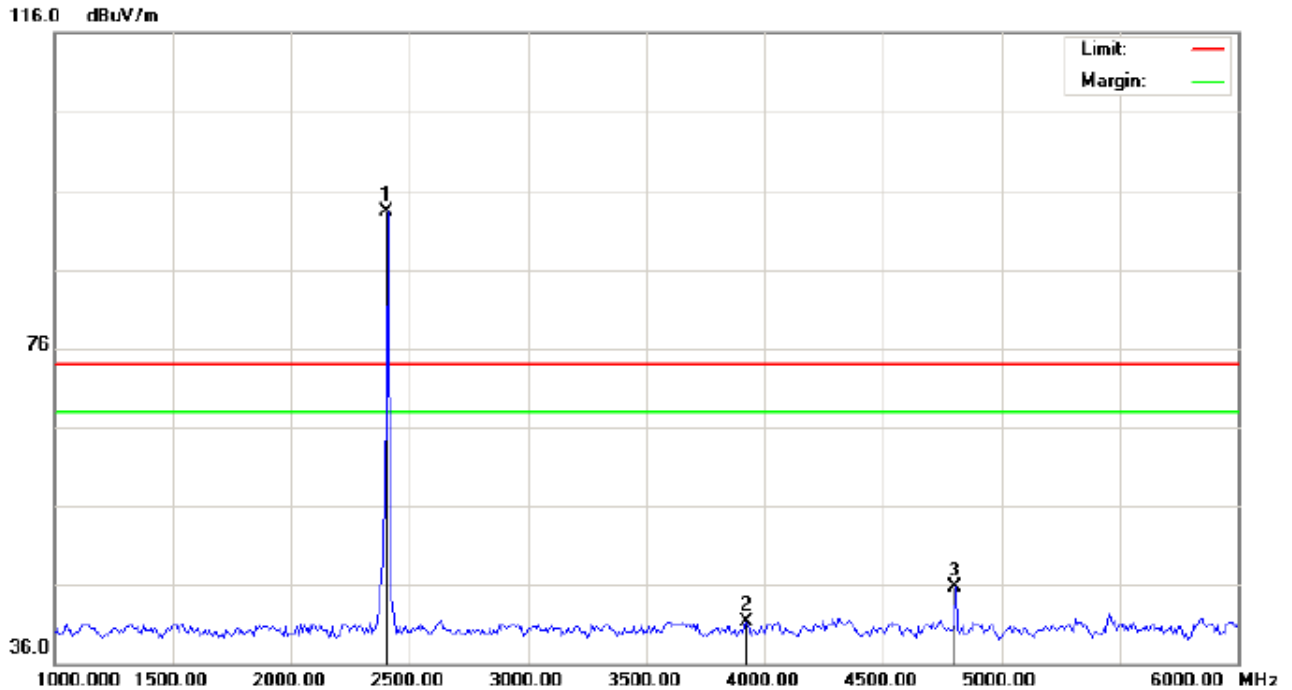

Site: site #1 Polarization: *Vertical* Temperature: 26
 Limit: FCC Class B 3M Radiation above 1GHZ(PK) Power: Humidity: 60 %
 EUT: Bluetooth intercom Distance:
 M/N: TTS
 Mode: Low Channel TX
 Note:

No.	Mk	Freq.	Reading	Factor	Measurement	Limit	Over	Detector	Antenna Height	Table Degree	Comment
		MHz	dBuV	dB/m	dBuV/m	dBuV/m	dB		cm	degree	
1	*	2402.000	82.94	10.32	93.26	74.00	19.26	peak			
2		3925.000	26.67	14.73	41.40	74.00	-32.60	peak			
3		4804.000	38.05	7.69	45.74	74.00	-28.26	peak			

RESULT: PASS

Note: 1. Factor=Antenna Factor + Cable loss, Margin=Measurement-Limit.

2. The "Factor" value can be calculated automatically by software of measurement system.

RADIATED EMISSION TEST-(ABOVE 1GHZ)-MIDDLE CHANNEL-VERTICAL

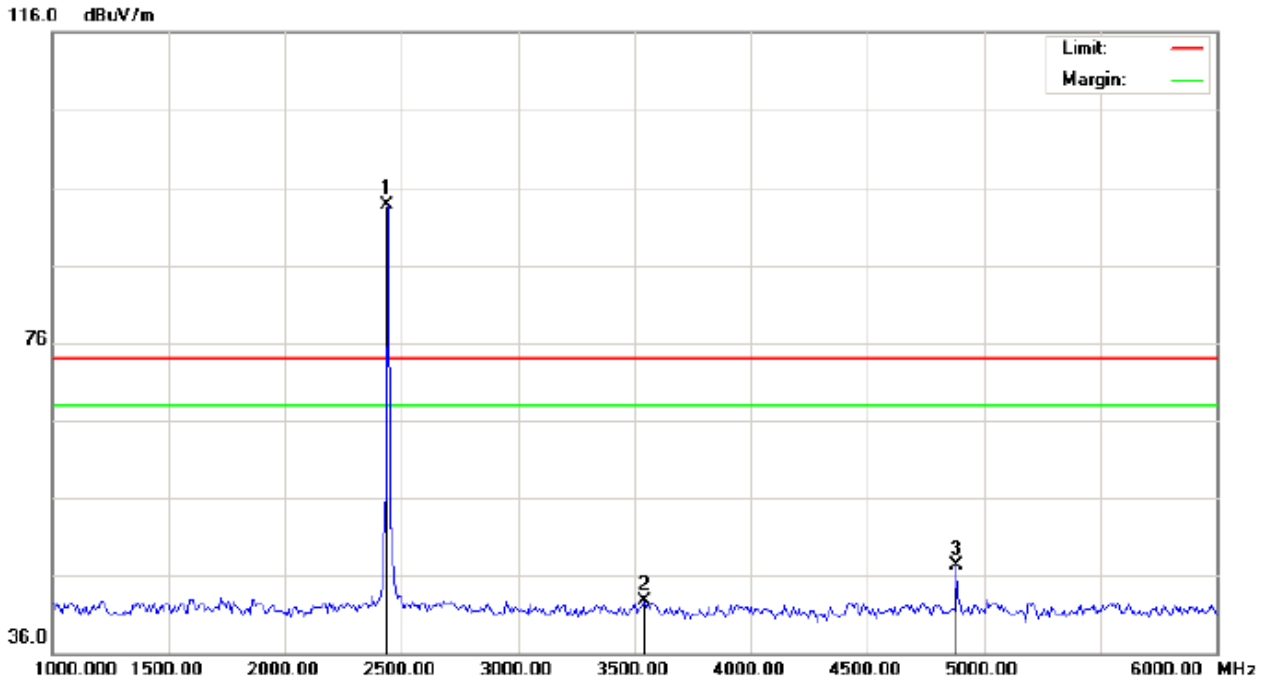

Site: site #1 Polarization: *Vertical* Temperature: 26
Limit: FCC Class B 3M Radiation above 1GHZ(PK) Power: Humidity: 60 %
EUT: Bluetooth intercom Distance:
M/N: TTS
Mode: Middle Channel TX
Note:

No.	Mk	Freq.	Reading	Factor	Measurement	Limit	Over	Detector	Antenna Height	Table Degree	Comment
		MHz	dBuV	dB/m	dBuV/m	dBuV/m	dB		cm	degree	
1	*	2440.000	83.39	10.36	93.75	74.00	19.75	peak			
2		3541.667	30.30	12.37	42.67	74.00	-31.33	peak			
3		4880.000	39.39	7.89	47.28	74.00	-26.72	peak			

RESULT: PASS

Note: 1. Factor=Antenna Factor + Cable loss, Margin=Measurement-Limit.
2. The "Factor" value can be calculated automatically by software of measurement system.

RADIATED EMISSION TEST-(ABOVE 1GHZ)-HIGH CHANNEL-HORIZONTAL

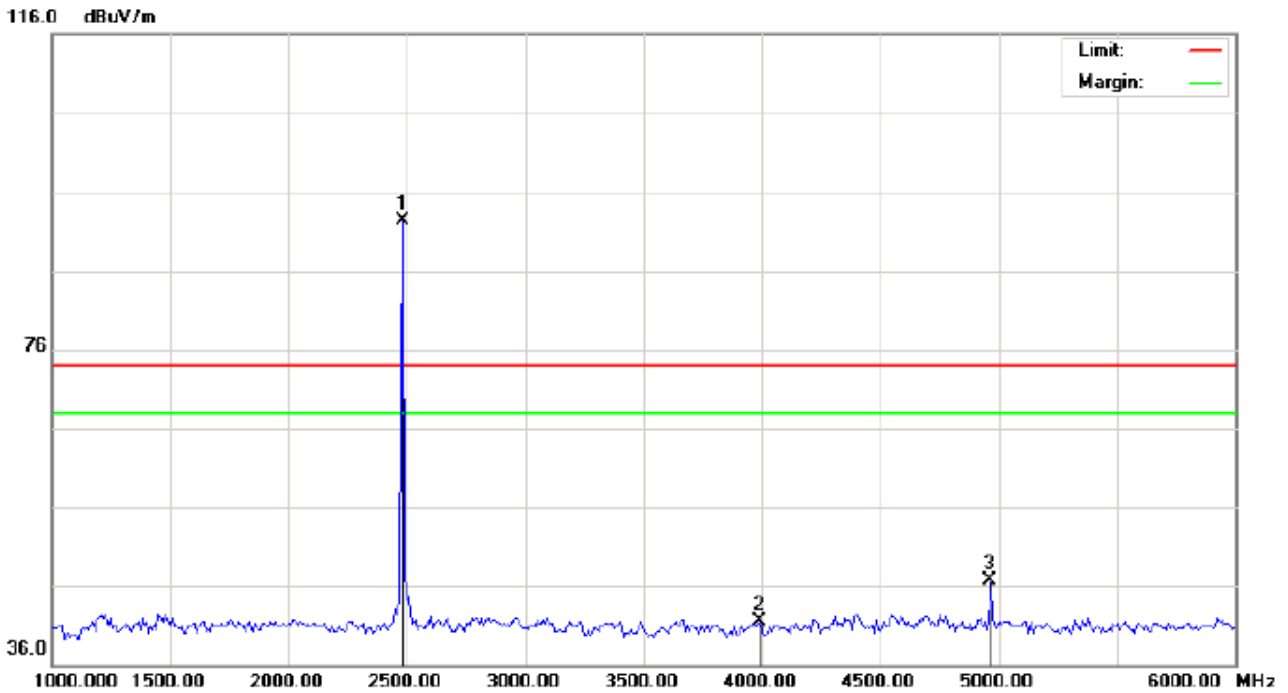

Site: site #1
Limit: FCC Class B 3M Radiation above 1GHZ(PK)
EUT: Bluetooth intercom
M/N: TTS
Mode: High Channel TX
Note:

Polarization: *Horizontal*
Power:
Distance:

Temperature: 26
Humidity: 60 %

No.	Mk	Freq.	Reading	Factor	Measurement	Limit	Over	Detector	Antenna Height	Table Degree	Comment
		MHz	dBuV	dB/m	dBuV/m	dBuV/m	dB		cm	degree	
1	*	2480.000	81.93	10.41	92.34	74.00	18.34	peak			
2		3991.667	26.32	15.14	41.46	74.00	-32.54	peak			
3		4960.000	38.60	8.09	46.69	74.00	-27.31	peak			

RESULT: PASS

RADIATED EMISSION TEST-(ABOVE 1GHZ)-HIGH CHANNEL-VERTICAL

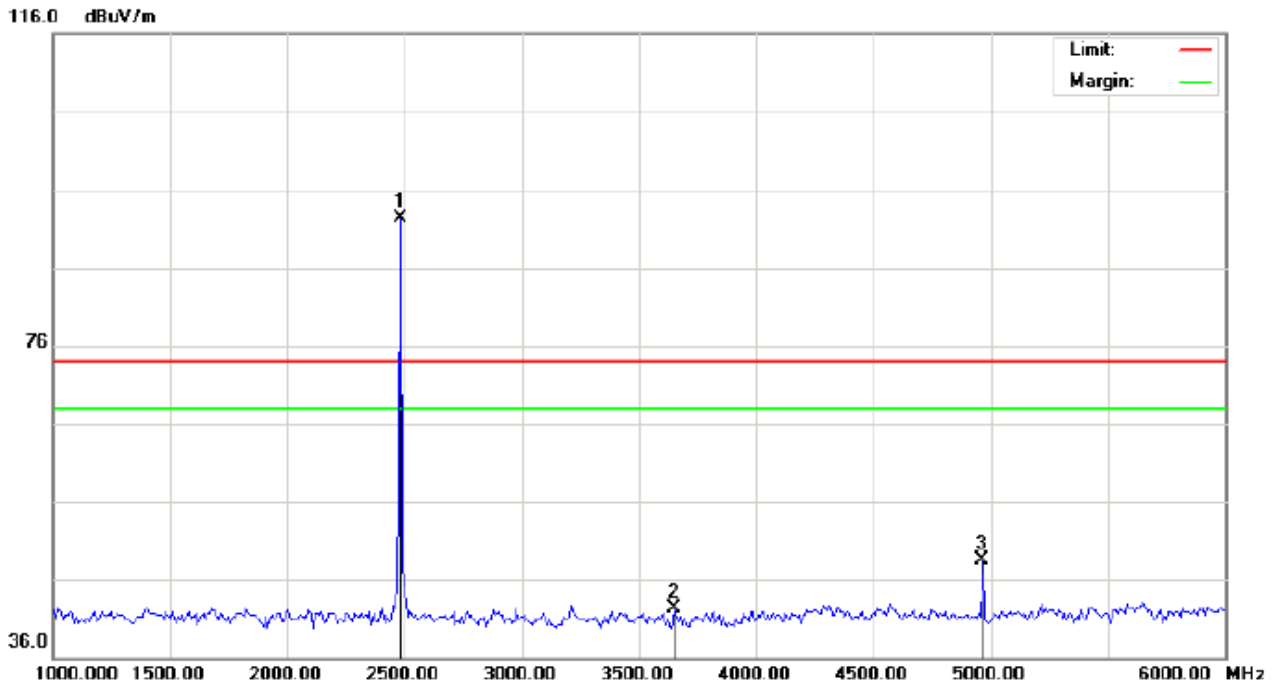

Site: site #1 Polarization: *Vertical* Temperature: 26
Limit: FCC Class B 3M Radiation above 1GHZ(PK) Power: Humidity: 60 %
EUT: Bluetooth intercom Distance:
M/N: TTS
Mode: High Channel TX
Note:

No.	Mk	Freq.	Reading	Factor	Measurement	Limit	Over	Detector	Antenna Height	Table Degree	Comment
		MHz	dBuV	dB/m	dBuV/m	dBuV/m	dB		cm	degree	
1	*	2480.000	81.97	10.41	92.38	74.00	18.38	peak			
2		3650.000	29.34	13.03	42.37	74.00	-31.63	peak			
3		4960.000	40.41	8.09	48.50	74.00	-25.50	peak			

RESULT: PASS

Note: 6~25GHz at least have 20dB margin. No recording in the test report.

Factor=Antenna Factor+ Cable loss-Amplifier gain,

Margin=Measurement-Limit.

The "Factor" value can be calculated automatically by software of measurement system.

8. BAND EDGE EMISSION

8.1. MEASUREMENT PROCEDURE

1. Set the EUT Work on the top, the bottom operation frequency individually.
2. Set SPA Start or Stop Frequency=Operation Frequency, $RBW \geq 100\text{kHz}$, $VBW \geq 3 \cdot RBW$,
Center frequency =Operation frequency
3. The band edges was measured and recorded.

8.2. TEST SET-UP

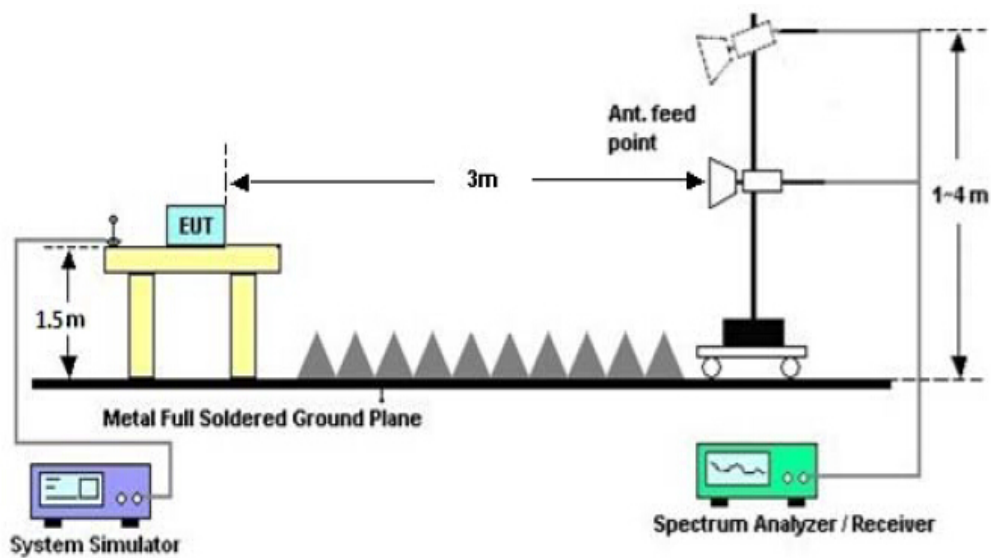

TEST PLOT OF BAND EDGE FOR HIGH CHANNEL –Horizontal

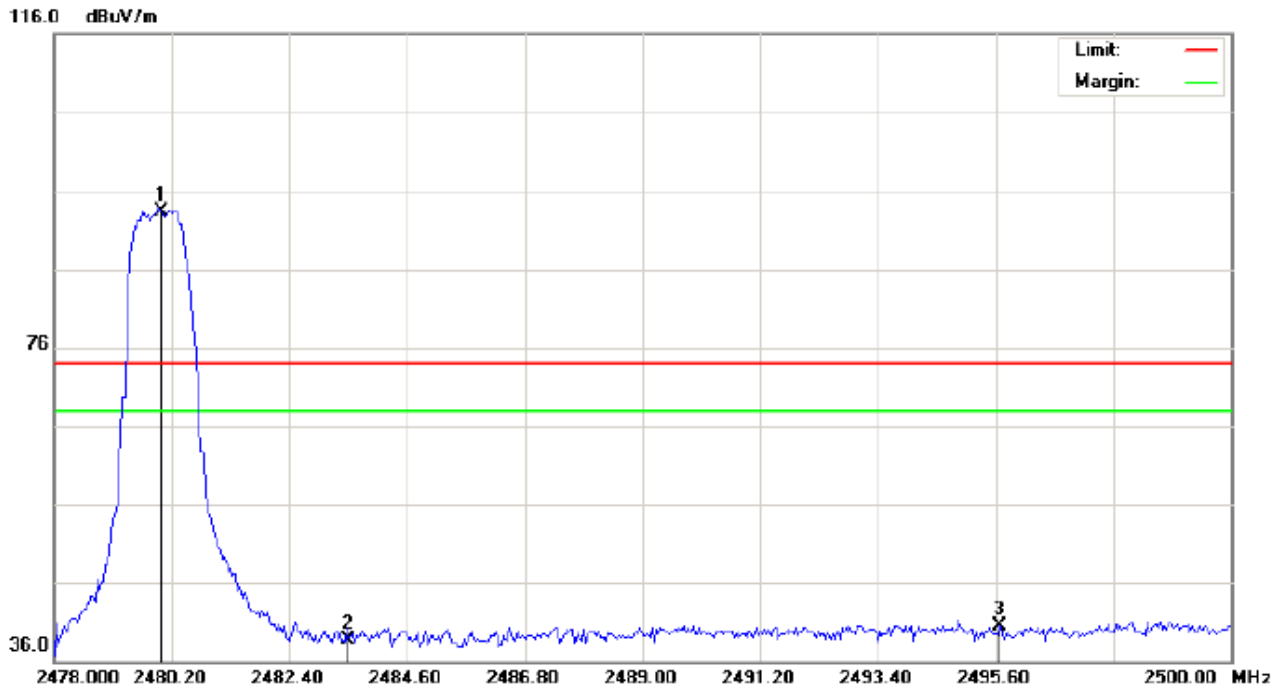

Site: site #1 Polarization: *Horizontal* Temperature: 26
Limit: FCC Class B 3M Radiation above 1GHZ(PK) Power: Humidity: 60 %
EUT: Bluetooth intercom Distance:
M/N: TTS
Mode: High Channel TX
Note:

No.	Mk	Freq.	Reading	Factor	Measurement	Limit	Over	Detector	Antenna Height	Table Degree	Comment
		MHz	dBuV	dB/m	dBuV/m	dBuV/m	dB		cm	degree	
1	*	2480.000	82.96	10.41	93.37	74.00	19.37	peak			
2		2483.500	28.25	10.41	38.66	74.00	-35.34	peak			
3		2495.673	30.15	10.43	40.58	74.00	-33.42	peak			

TEST PLOT OF BAND EDGE FOR HIGH CHANNEL -Vertical

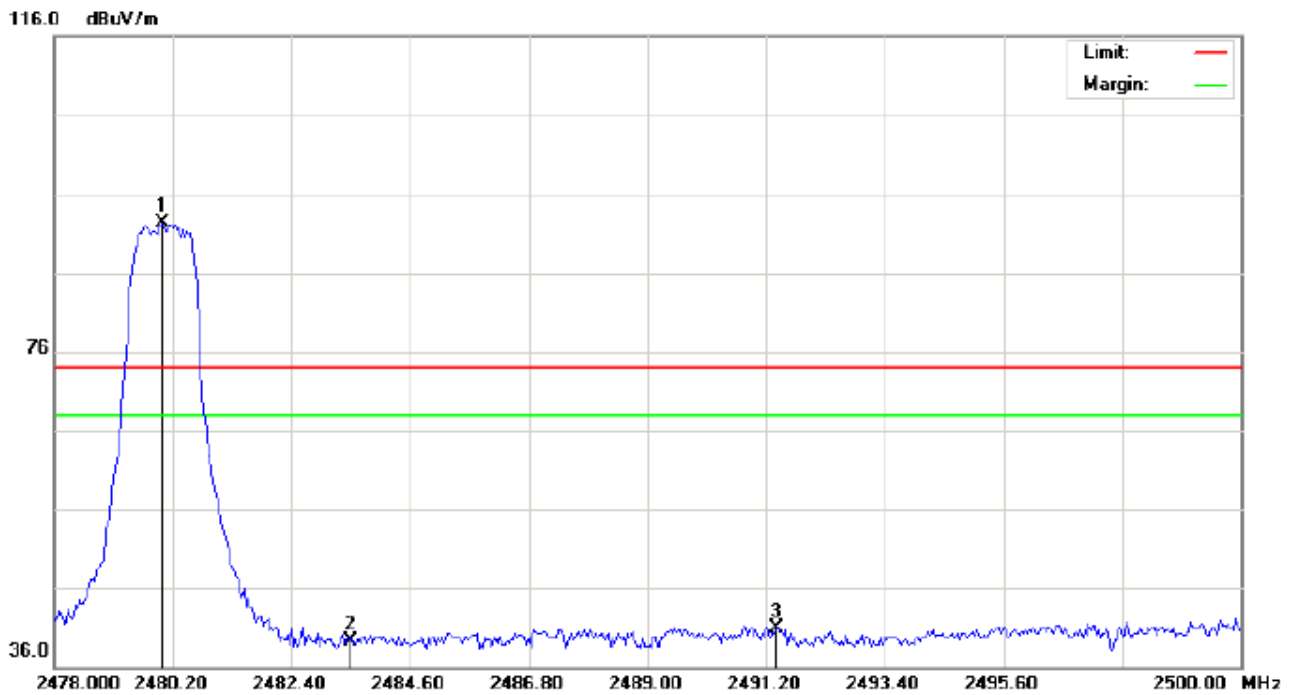

Site: site #1 Polarization: *Vertical* Temperature: 26
Limit: FCC Class B 3M Radiation above 1GHZ(PK) Power: Humidity: 60 %
EUT: Bluetooth intercom Distance:
M/N: TTS
Mode: High Channel TX
Note:

No.	Mk	Freq.	Reading	Factor	Measurement	Limit	Over	Detector	Antenna Height	Table Degree	Comment
		MHz	dBuV	dB/m	dBuV/m	dBuV/m	dB		cm	degree	
1	*	2480.000	81.85	10.41	92.26	74.00	18.26	peak			
2		2483.500	28.87	10.41	39.28	74.00	-34.72	peak			
3		2491.383	30.44	10.42	40.86	74.00	-33.14	peak			

RESULT: PASS

9. 6DB BANDWIDTH

9.1. TEST PROCEDURE

1. Connect EUT RF output port to the Spectrum Analyzer through an RF attenuator
2. Set the EUT Work on the top, the middle and the bottom operation frequency individually.
3. Set SPA Centre Frequency = Operation Frequency, RBW= 100 KHz, VBW \geq 3*RBW.
4. Set SPA Trace 1 Max hold, then View.

9.2. SUMMARY OF TEST RESULTS/PLOTS

Channel	6dB Bandwidth (KHz)	Minimum Limit (KHz)	Pass/Fail
Low	0.706	500KHz	Pass
Middle	0.696		Pass
High	0.709		Pass

TEST PLOT OF BANDWIDTH FOR LOW CHANNEL

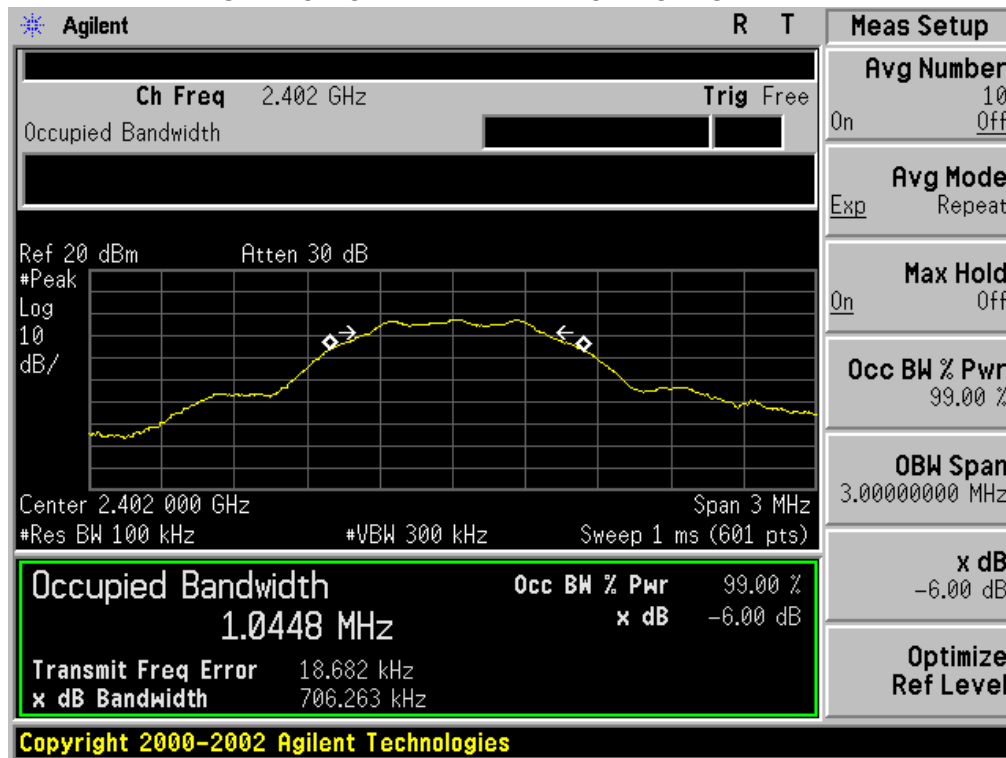

TEST PLOT OF BANDWIDTH FOR MIDDLE CHANNEL

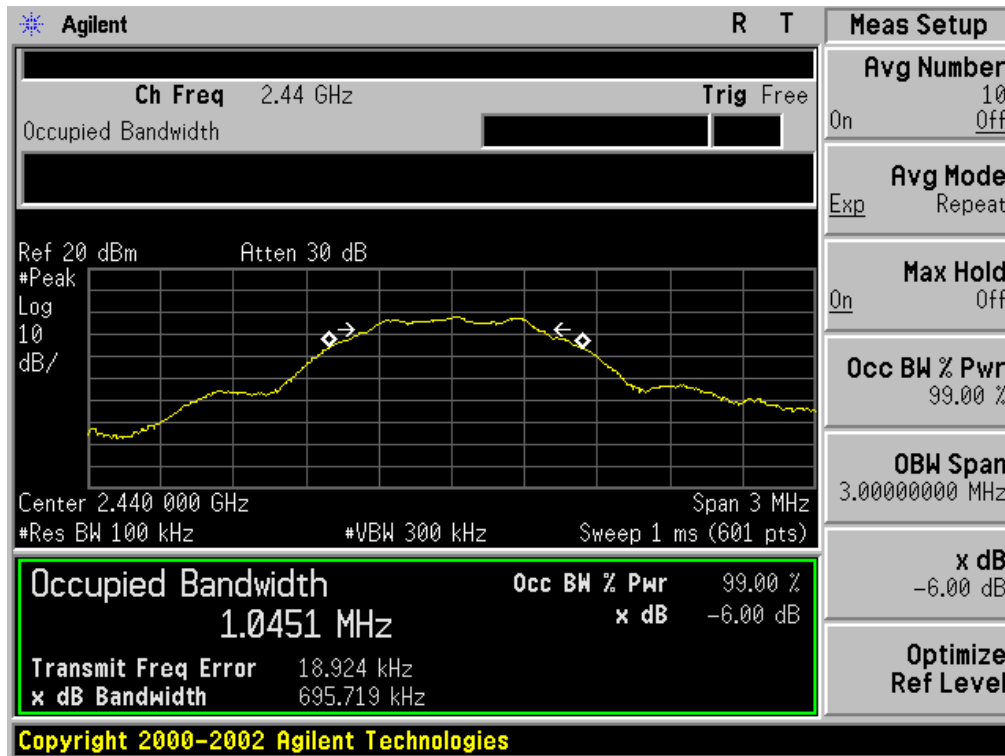

TEST PLOT OF BANDWIDTH FOR HIGH CHANNEL

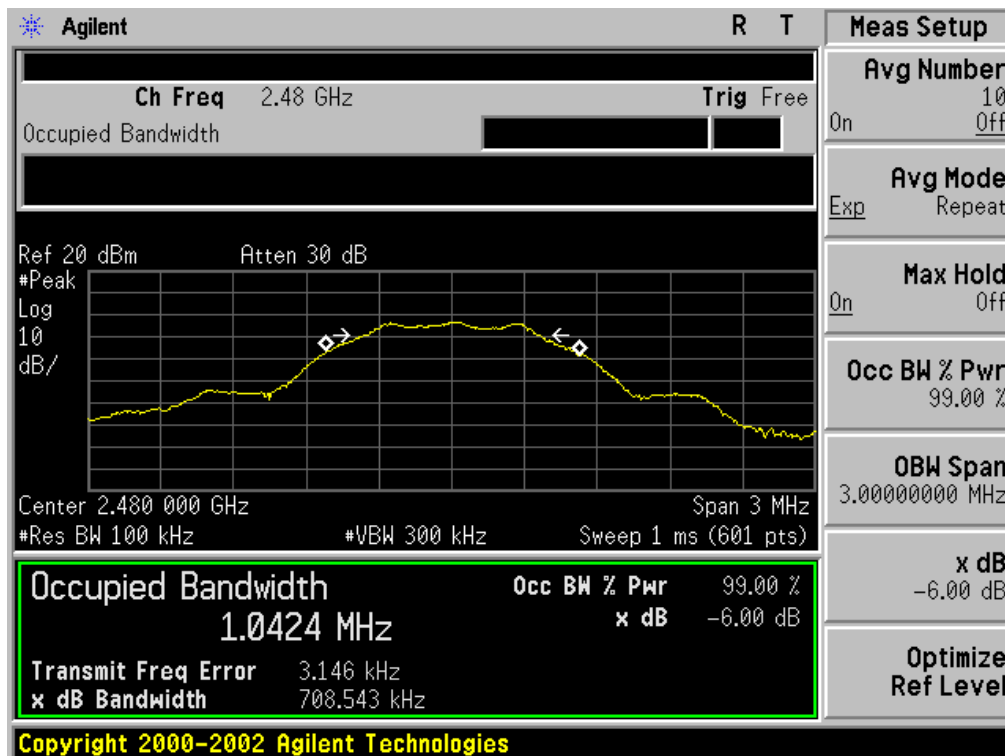

10. CONDUCTED OUTPUT POWER

10.1. MEASUREMENT PROCEDURE

For peak power test:

1. Connect EUT RF output port to the Spectrum Analyzer through an RF attenuator
2. Set the EUT Work on the top, middle and the bottom operation frequency individually.
3. Use the following spectrum analyzer settings:
 - a) Set the RBW \geq DTS bandwidth.
 - b) Set VBW ≥ 3 RBW.
 - c) Set span $\geq 3 \times$ RBW
 - d) Sweep time = auto couple.
 - e) Detector = peak.
 - f) Trace mode = max hold.
 - g) Allow trace to fully stabilize.
 - h) Use peak marker function to determine the peak amplitude level.
4. Allow the trace to stabilize.
5. Record the result form the Spectrum Analyzer.

10.2. TEST SET-UP (BLOCK DIAGRAM OF CONFIGURATION)

Setup Diagram for Peak Power

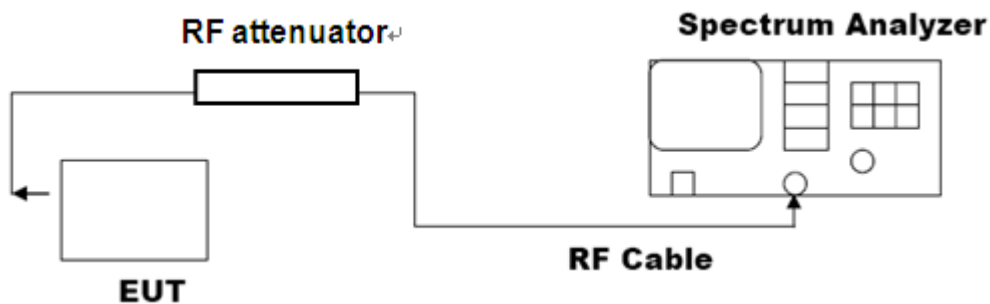

10.3. LIMITS AND MEASUREMENT RESULT

Channel	Peak Power (dBm)	Applicable Limits (dBm)	Pass/Fail
Low Channel	-2.07	30	Pass
Middle Channel	-1.58	30	Pass
High Channel	-2.76	30	Pass

The Low Channel Result

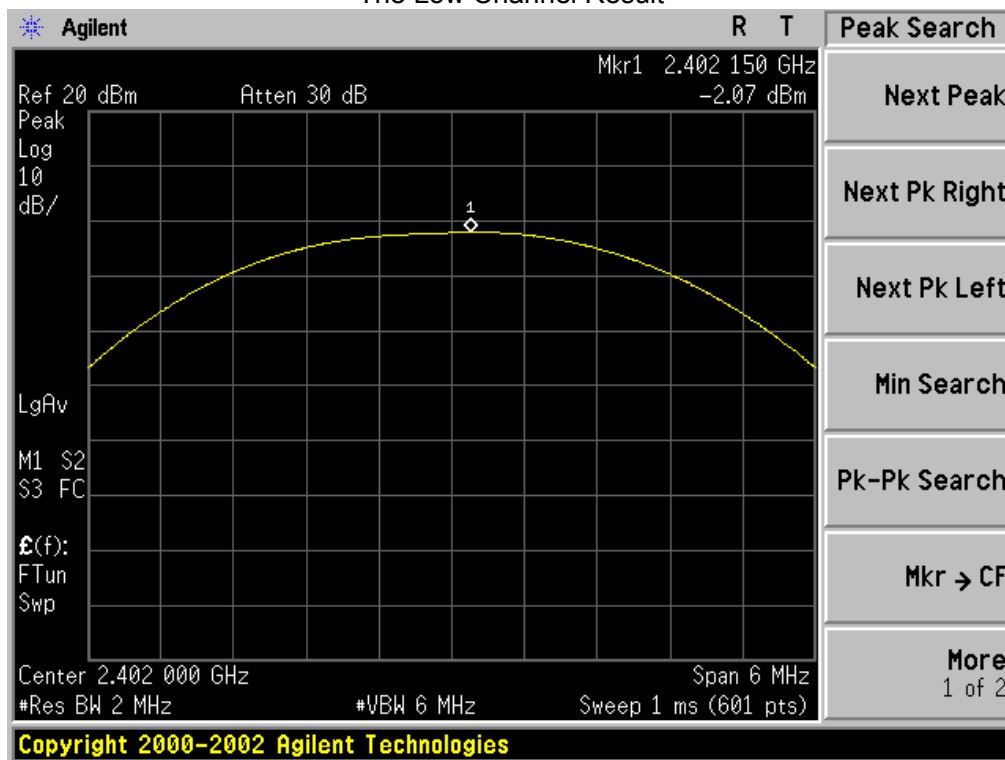

The Middle Channel Result

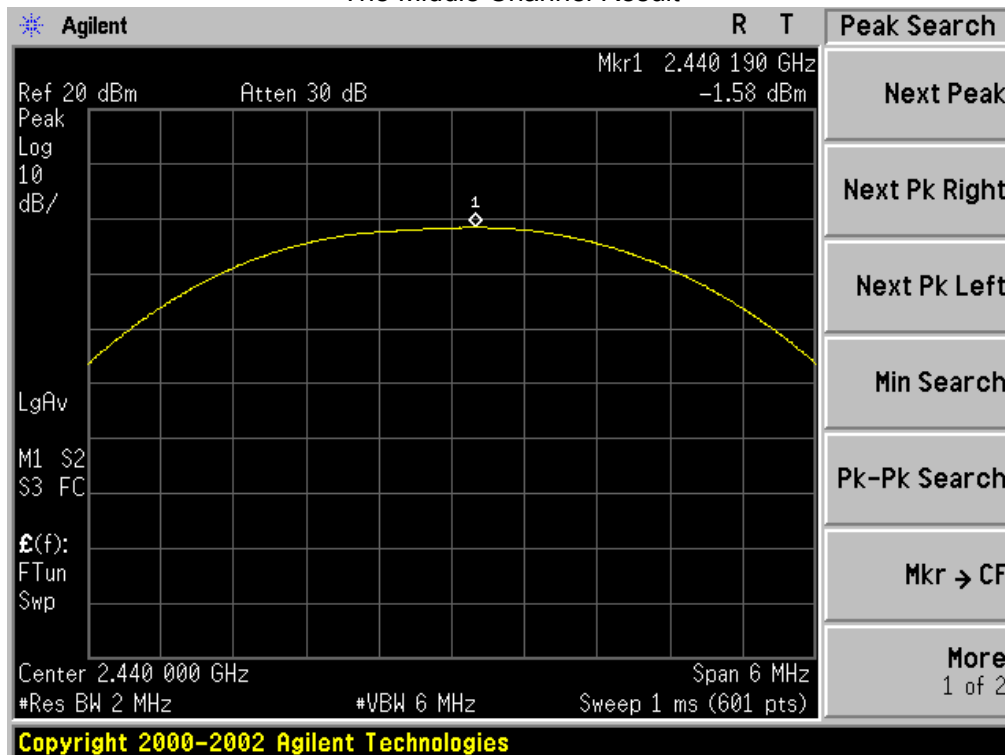

The High Channel Result

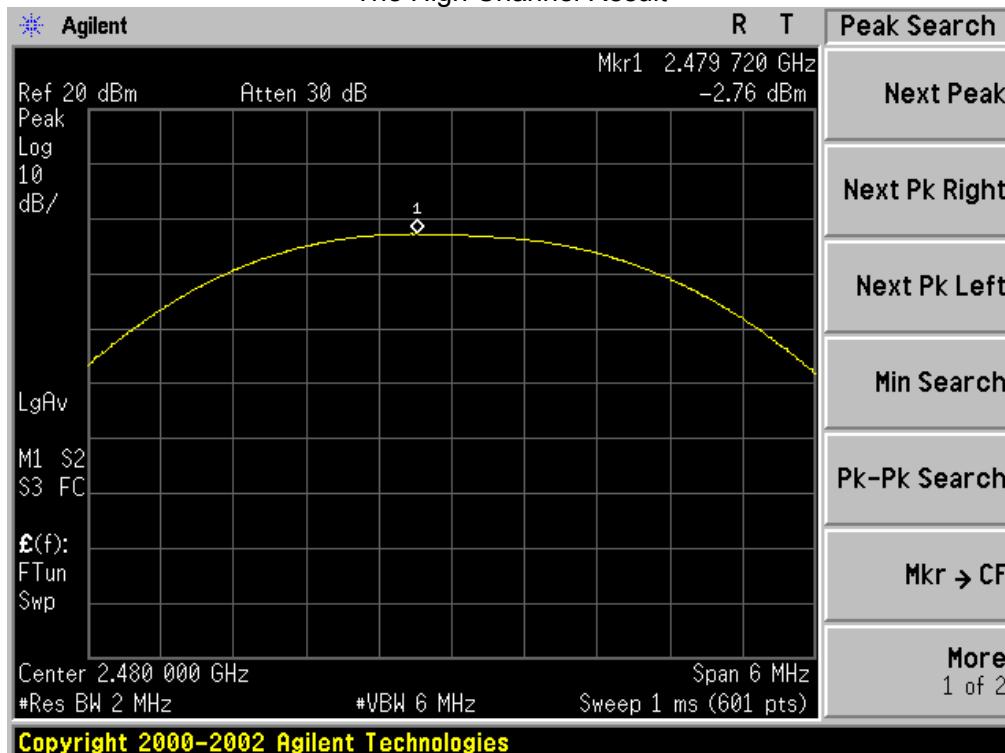

11. MAXIMUM CONDUCTED OUTPUT POWER SPECTRAL DENSITY

11.1 MEASUREMENT PROCEDURE

- (1). Connect EUT RF output port to the Spectrum Analyzer through an RF attenuator
- (2). Set the EUT Work on the top, the middle and the bottom operation frequency individually.
- (3). Set the span to 1.5times the DTS bandwidth, RBW: $3\text{kHz} \leq \text{RBW} \leq 100\text{kHz}$, $\text{VBW} = 3 * \text{RBW}$
- 4). Set SPA Trace 1 Max hold, then View.

Note: The EUT was tested according to KDB 558074 for compliance to FCC 47CFR 15.247 requirements.

11.2 TEST SET-UP (BLOCK DIAGRAM OF CONFIGURATION)

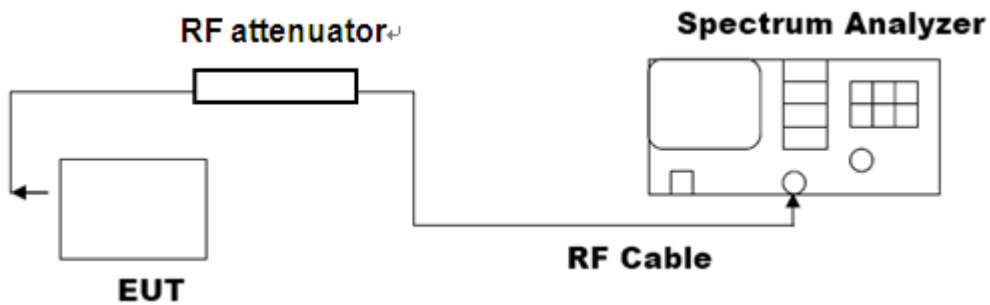

11.3 LIMITS AND MEASUREMENT RESULT

Channel No.	PSD (dBm/3KHz)	Limit (dBm/3KHz)	Result
Low Channel	-18.11	8	Pass
Middle Channel	-17.55	8	Pass
High Channel	-18.41	8	Pass

TEST PLOT OF SPECTRAL DENSITY FOR LOW CHANNEL

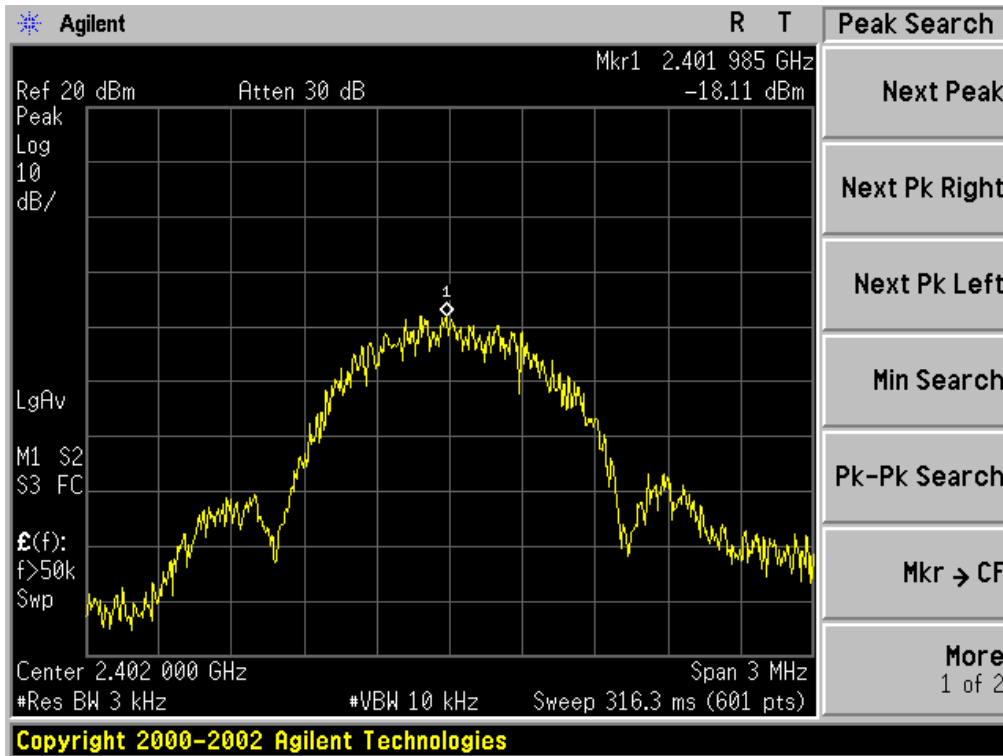

TEST PLOT OF SPECTRAL DENSITY FOR MIDDLE CHANNEL

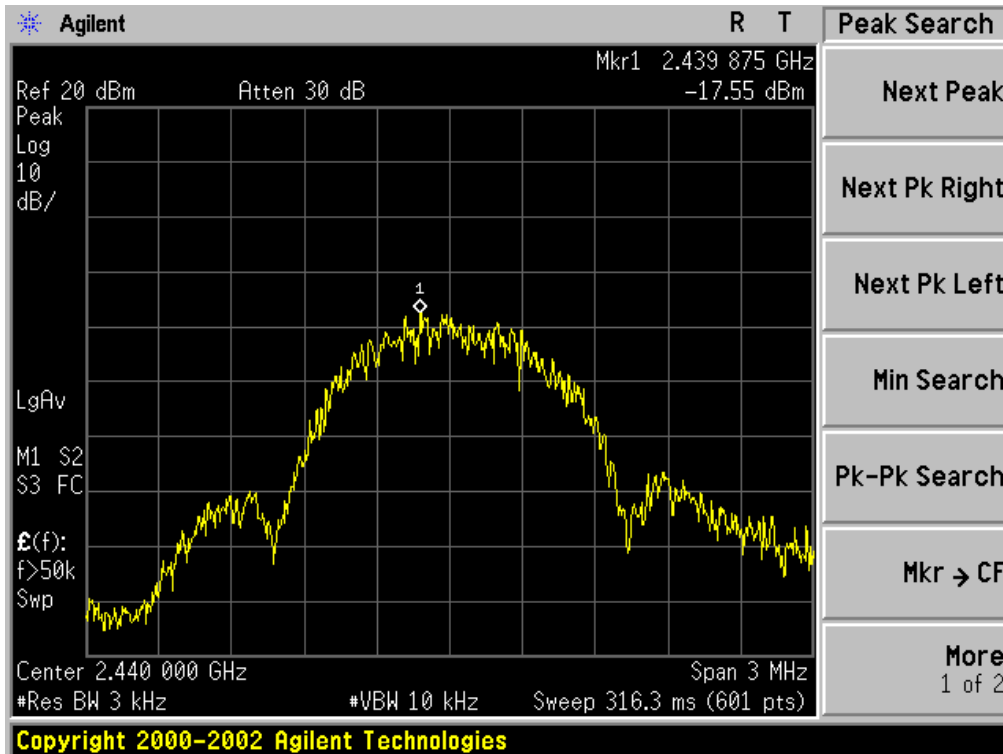

TEST PLOT OF SPECTRAL DENSITY FOR HIGH CHANNEL

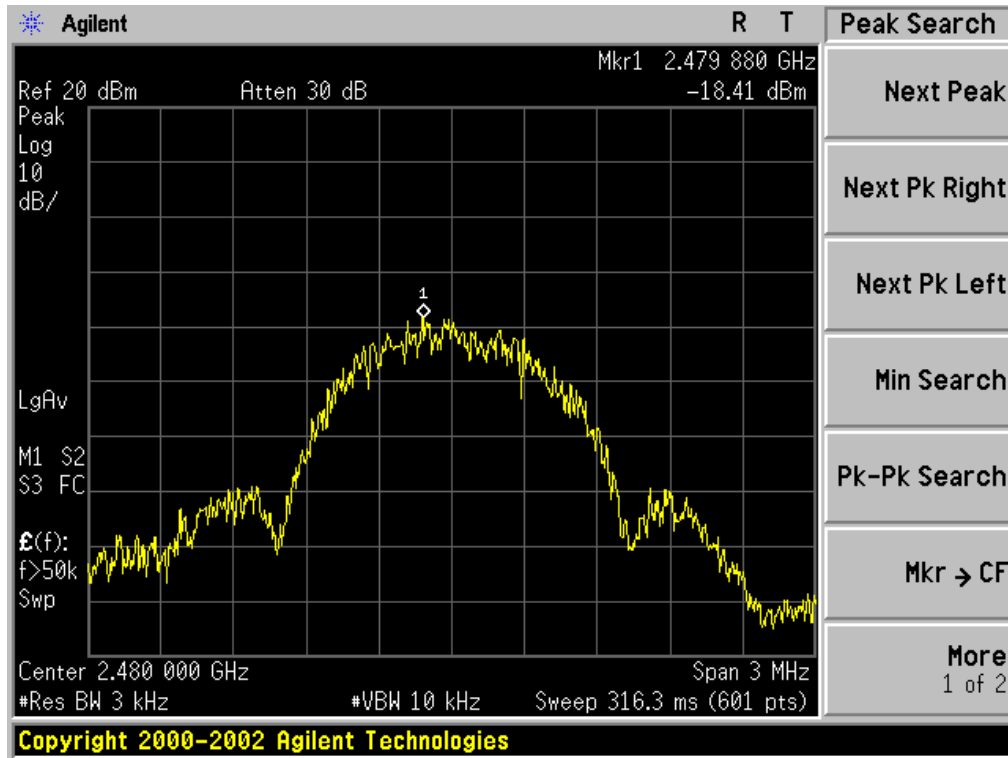

12. FCC LINE CONDUCTED EMISSION TEST

12.1 LIMITS

Frequency	Maximum RF Line Voltage	
	Q.P.(dBuV)	Average(dBuV)
150kHz~500kHz	66-56	56-46
500kHz~5MHz	56	46
5MHz~30MHz	60	50

- **Note:** 1. The lower limit shall apply at the transition frequency.
2. The limit decreases linearly with the logarithm of the frequency in the range 0.15 MHz to 0.50 MHz

12.2 TEST SETUP

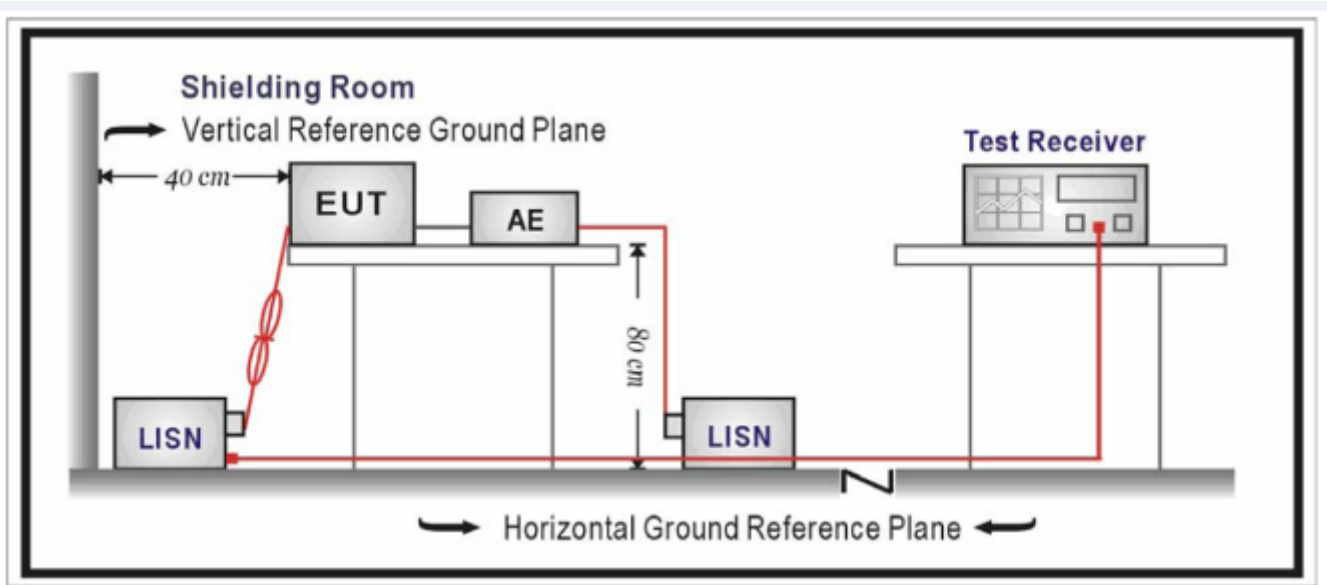

12.3 PRELIMINARY PROCEDURE

- 1) The equipment was set up as per the test configuration to simulate typical actual usage per the user's manual. When the EUT is a tabletop system, a wooden table with a height of 0.8 meters is used and is placed on the ground plane as per ANSI C63.10 (see Test Facility for the dimensions of the ground plane used). When the EUT is a floor-standing equipment, it is placed on the ground plane which has a 3-12 mm non-conductive covering to insulate the EUT from the ground plane.
- 2) Support equipment, if needed, was placed as per ANSI C63.10.
- 3) All I/O cables were positioned to simulate typical actual usage as per ANSI C63.10.
- 4) All support equipments received AC120V/60Hz power from a LISN, if any.
- 5) The EUT received DC charging voltage by PC or by adapter which received 120V/60Hz power by a LISN.
- 6) The test program was started. Emissions were measured on each current carrying line of the EUT using a spectrum Analyzer / Receiver connected to the LISN powering the EUT. The LISN has two monitoring points: Line 1 (Hot Side) and Line 2 (Neutral Side). Two scans were taken: one with Line 1 connected to Analyzer / Receiver and Line 2 connected to a 50 ohm load; the second scan had Line 1 connected to a 50 ohm load and Line 2 connected to the Analyzer / Receiver.
- 7) Analyzer / Receiver scanned from 150 kHz to 30MHz for emissions in each of the test modes.
- 8) During the above scans, the emissions were maximized by cable manipulation.
- 9) The following test mode(s) were scanned during the preliminary test.
Then, the EUT configuration and cable configuration of the above highest emission level were recorded for reference of final testing.

12.4 FINAL TEST PROCEDURE

- 1) EUT and support equipment was set up on the test bench as per step 2 of the preliminary test.
- 2) A scan was taken on both power lines, Line 1 and Line 2, recording at least the six highest emissions. Emission frequency and amplitude were recorded into a computer in which correction factors were used to calculate the emission level and compare reading to the applicable limit. If EUT emission level was less -2dB to the A.V. limit in Peak mode, then the emission signal was re-checked using Q.P and Average detector.
- 3) The test data of the worst case condition(s) was reported on the Summary Data page.

**12.5 TEST RESULT OF POWER LINE
Worst Case (By Adapter)**

Line Conducted Emission Test Line 1-L

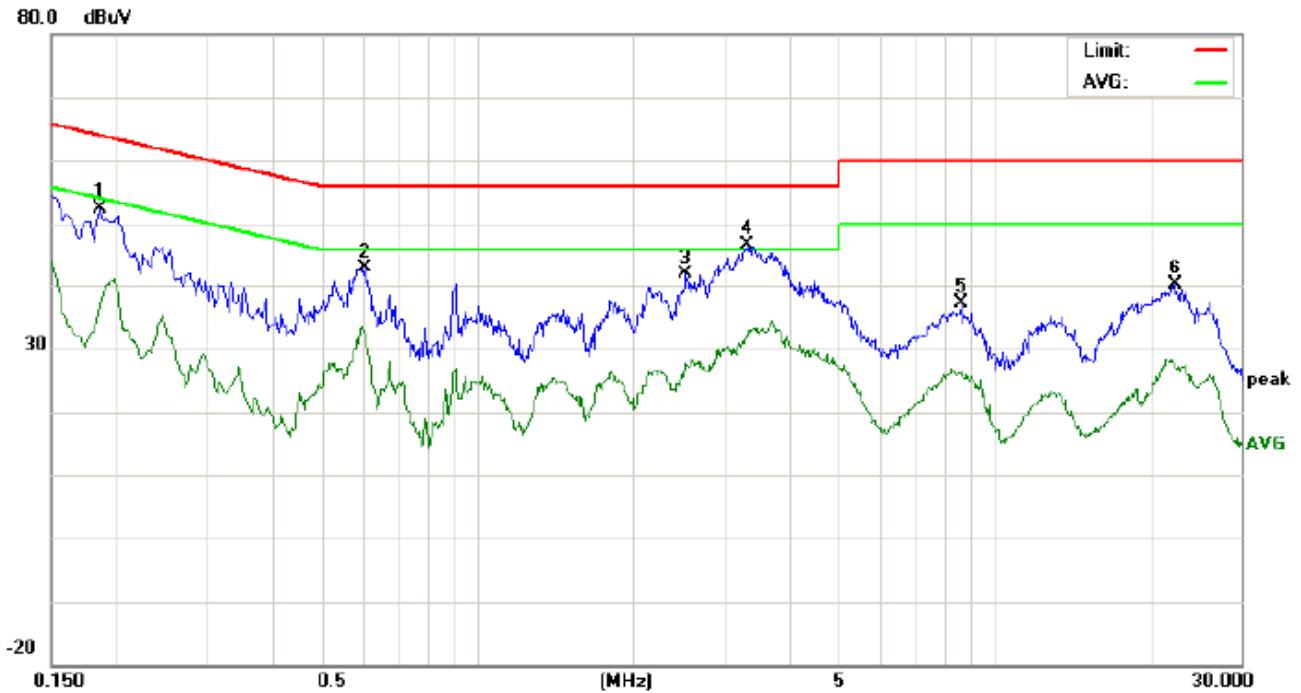

Site: Conduction Phase: **L1** Temperature: 24.8
Limit: FCC Class B Conduction(QP) Power: Humidity: 52.6 %
EUT: Bluetooth intercom
M/N: TTS
Mode: BT Link with charging
Note:

No.	Freq. (MHz)	Reading_Level (dBuV)			Correct Factor (dB)	Measurement (dBuV)			Limit (dBuV)		Margin (dB)		P/F	Comment
		Peak	QP	AVG		Peak	QP	AVG	QP	AVG	QP	AVG		
1	0.1859	42.27		26.70	10.20	52.47		36.90	64.21	54.21	-11.74	-17.31	P	
2	0.6059	32.64		21.73	10.31	42.95		32.04	56.00	46.00	-13.05	-13.96	P	
3	2.5339	31.45		17.15	10.44	41.89		27.59	56.00	46.00	-14.11	-18.41	P	
4	3.3140	36.08		21.73	10.52	46.60		32.25	56.00	46.00	-9.40	-13.75	P	
5	8.6019	26.74		16.17	10.31	37.05		26.48	60.00	50.00	-22.95	-23.52	P	
6	22.3140	29.92		17.35	10.12	40.04		27.47	60.00	50.00	-19.96	-22.53	P	

Line Conducted Emission Test Line 2-N

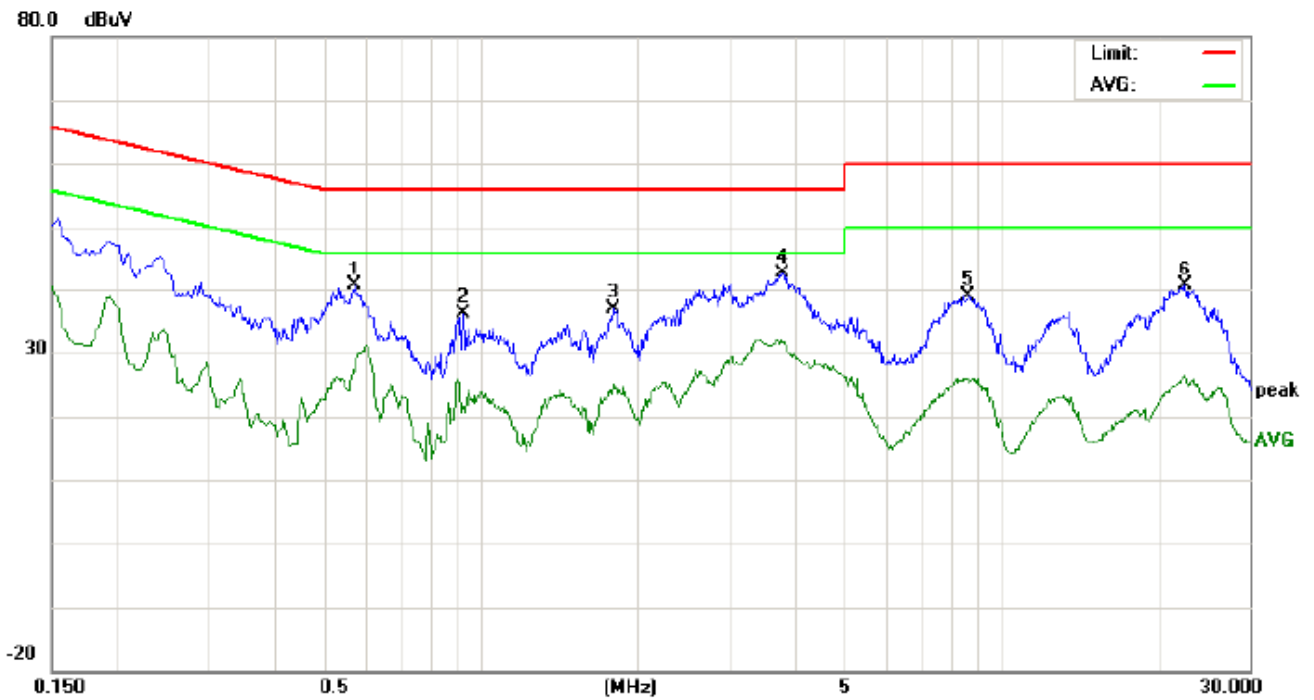

Site: Conduction Phase: **N** Temperature: 24.8
Limit: FCC Class B Conduction(QP) Power: Humidity: 52.6 %
EUT: Bluetooth intercom
M/N: TTS
Mode: BT Link with charging
Note:

No.	Freq. (MHz)	Reading_Level (dBuV)			Correct Factor (dB)	Measurement (dBuV)			Limit (dBuV)		Margin (dB)		P/F	Comment
		Peak	QP	AVG		Peak	QP	AVG	QP	AVG	QP	AVG		
1	0.5740	30.37		16.78	10.33	40.70		27.11	56.00	46.00	-15.30	-18.89	P	
2	0.9260	25.62		11.13	10.40	36.02		21.53	56.00	46.00	-19.98	-24.47	P	
3	1.7940	26.66		14.44	10.29	36.95		24.73	56.00	46.00	-19.05	-21.27	P	
4	3.8100	32.19		21.08	10.46	42.65		31.54	56.00	46.00	-13.35	-14.46	P	
5	8.6379	28.69		15.56	10.30	38.99		25.86	60.00	50.00	-21.01	-24.14	P	
6	22.6180	30.59		16.34	10.11	40.70		26.45	60.00	50.00	-19.30	-23.55	P	

APPENDIX A: PHOTOGRAPHS OF TEST SETUP

FCC LINE CONDUCTED EMISSION TEST SETUP

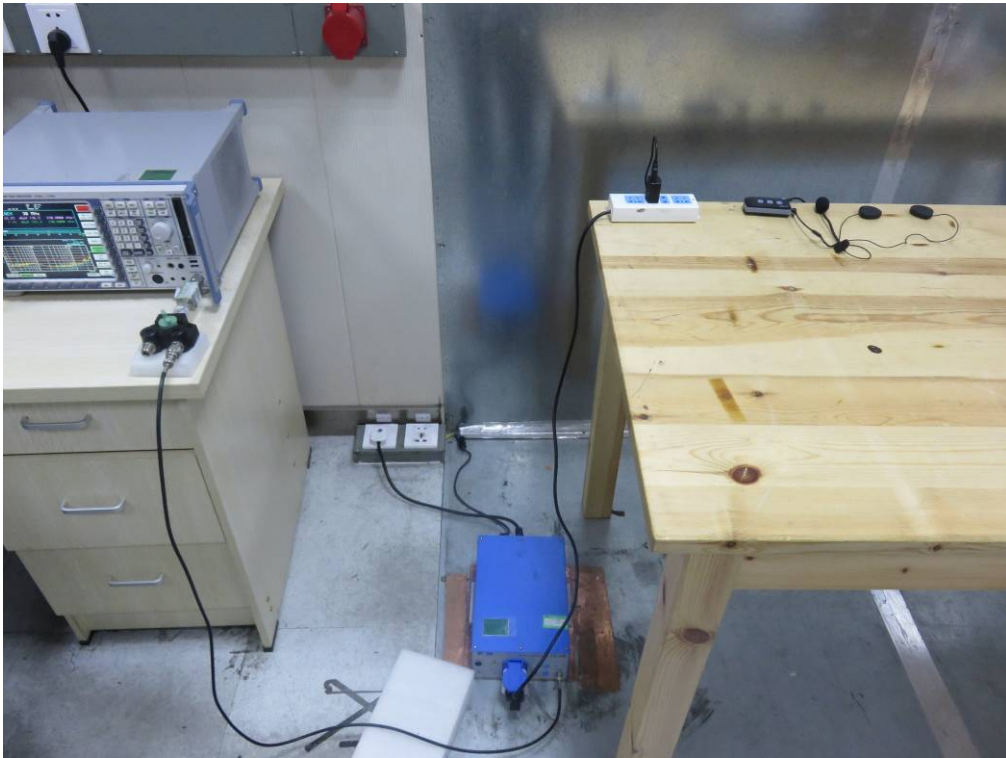

FCC RADIATED EMISSION TEST SETUP

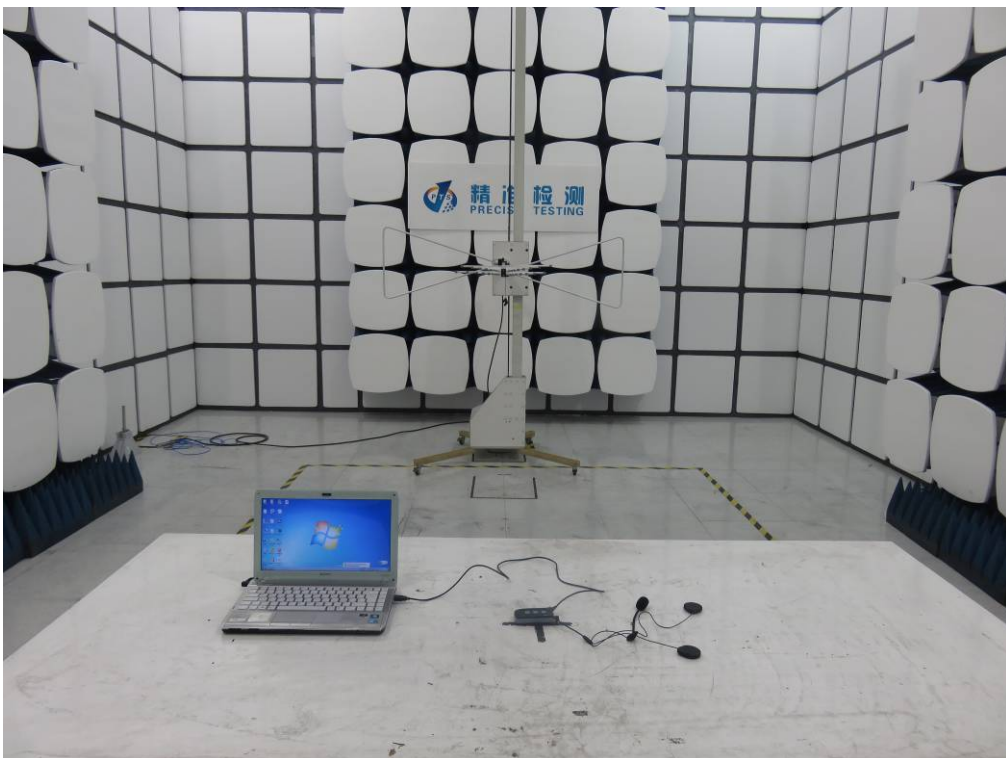

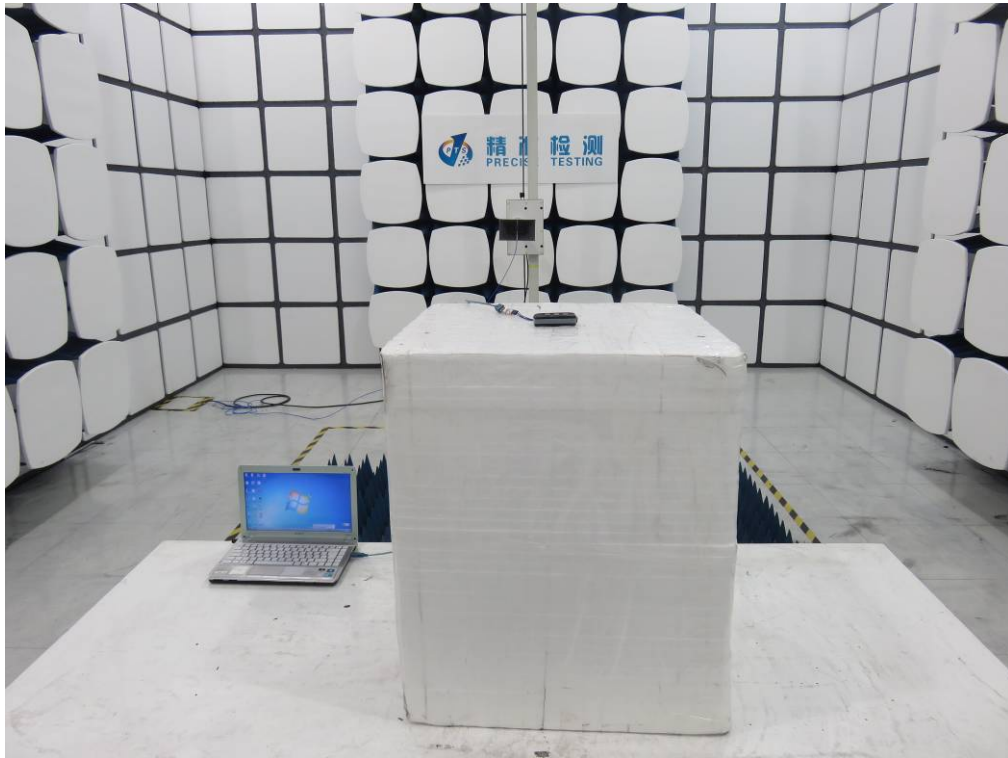

APPENDIX B: PHOTOGRAPHS OF EUT TOTAL VIEW OF EUT



TOP VIEW OF EUT



BOTTOM VIEW OF EUT

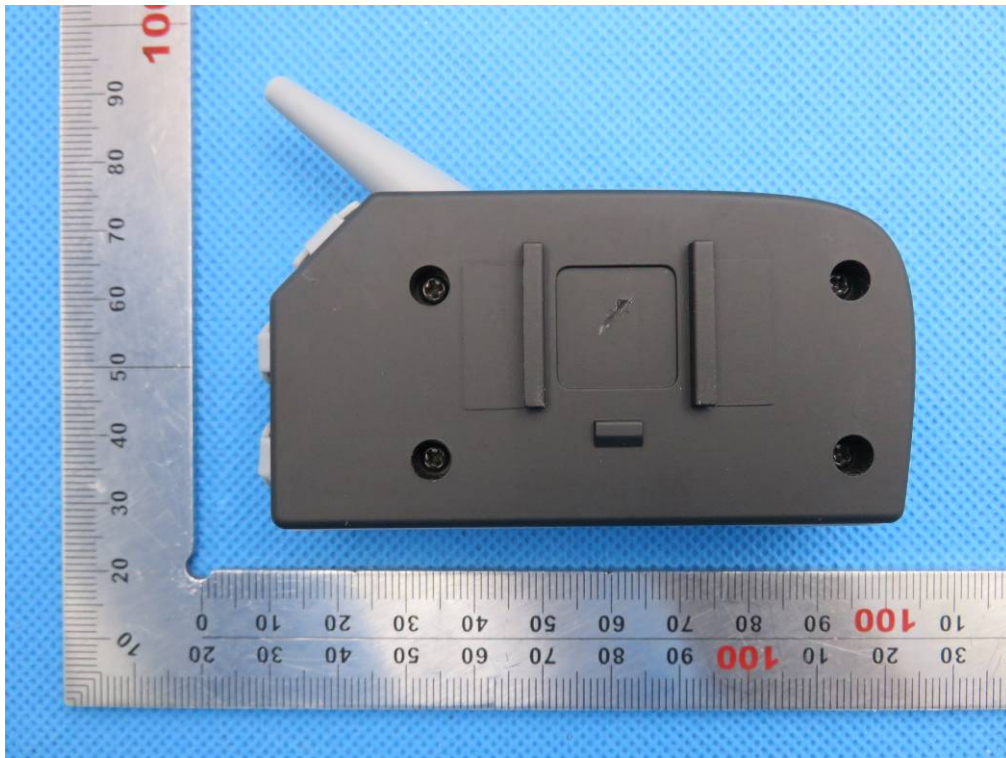

FRONT VIEW OF EUT



BACK VIEW OF EUT

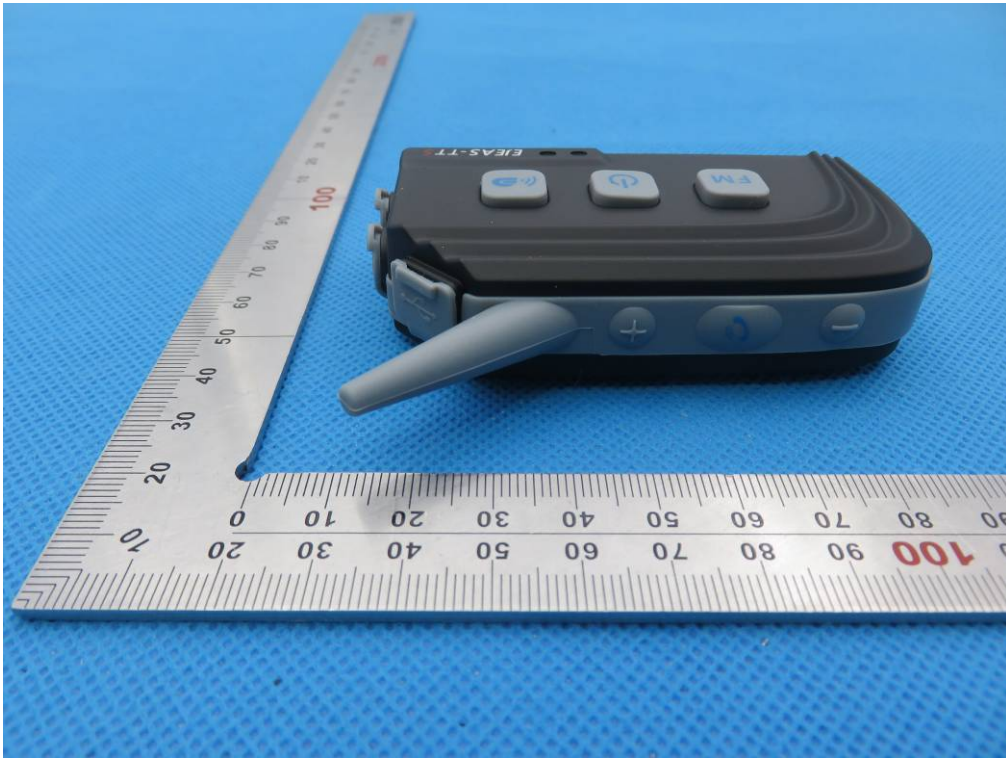

LEFT VIEW OF EUT



RIGHT VIEW OF EUT



VIEW OF EUT (USB Port)

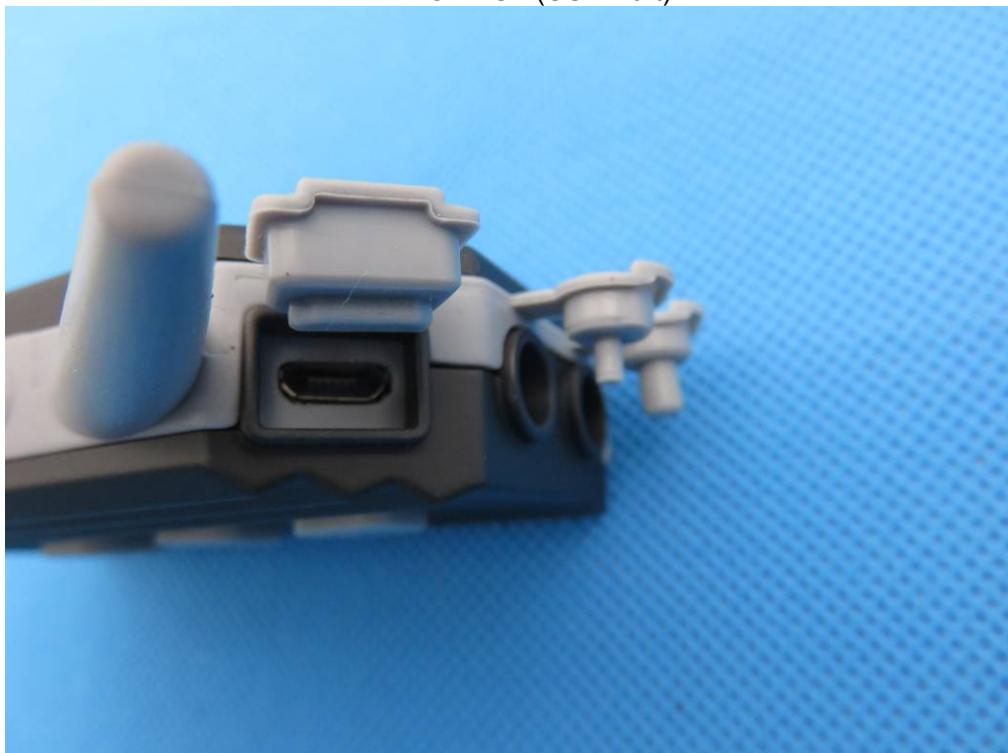

VIEW OF EUT (Audio Port)



OPEN VIEW OF EUT

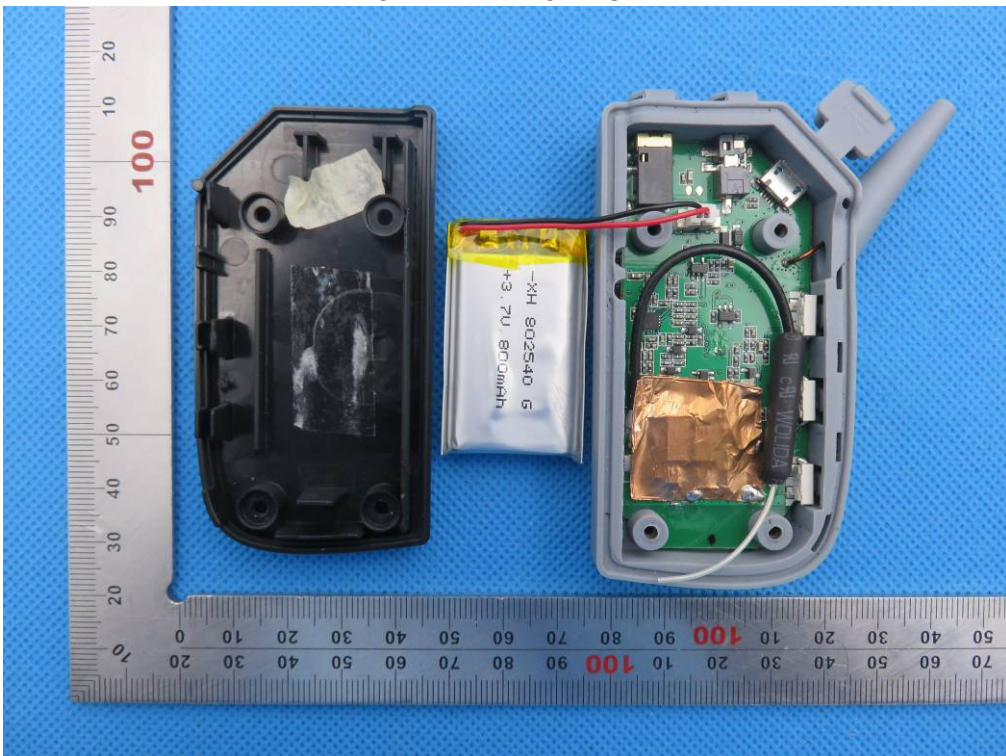

INTERNAL VIEW OF EUT-1

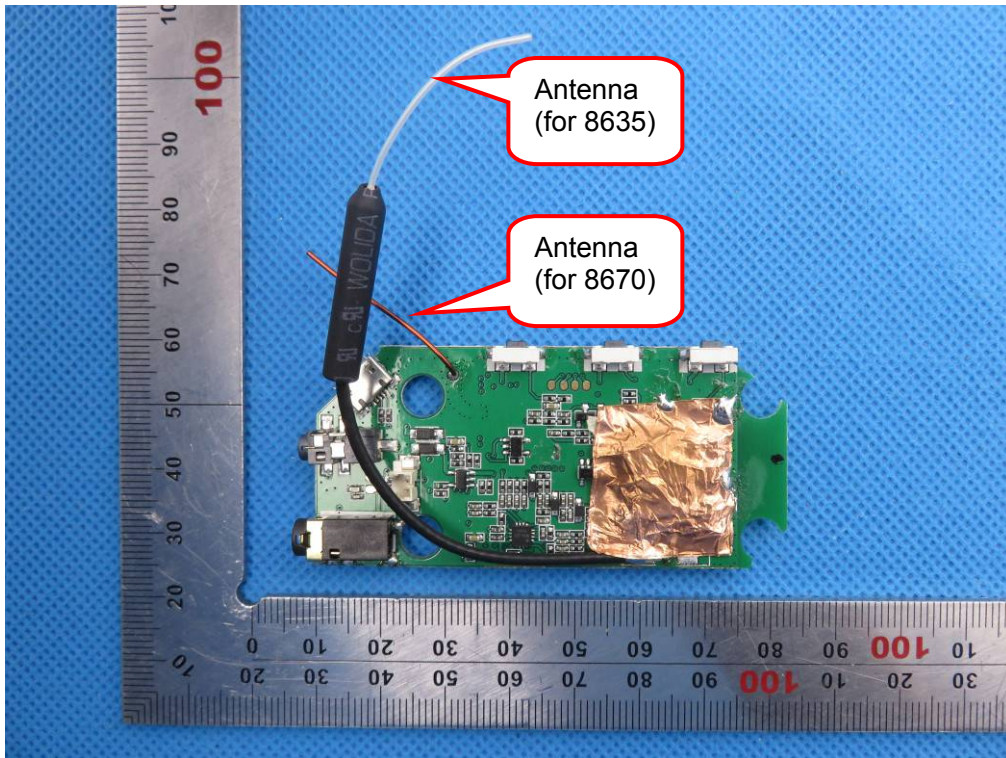

INTERNAL VIEW OF EUT-2(8635)

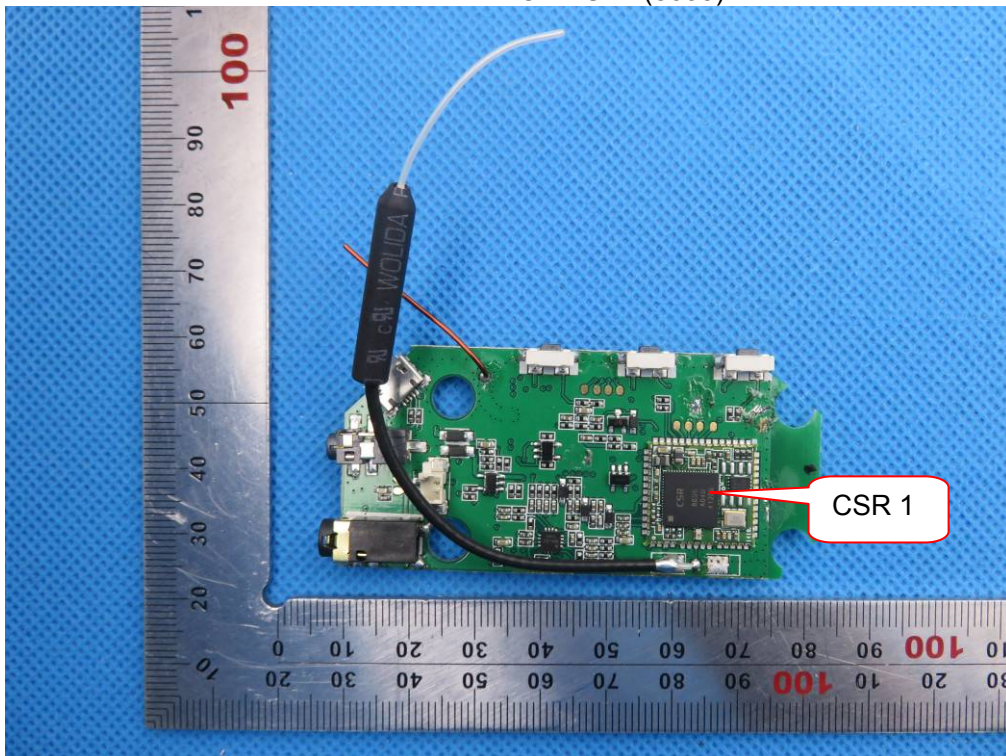

INTERNAL VIEW OF EUT-3(8635)

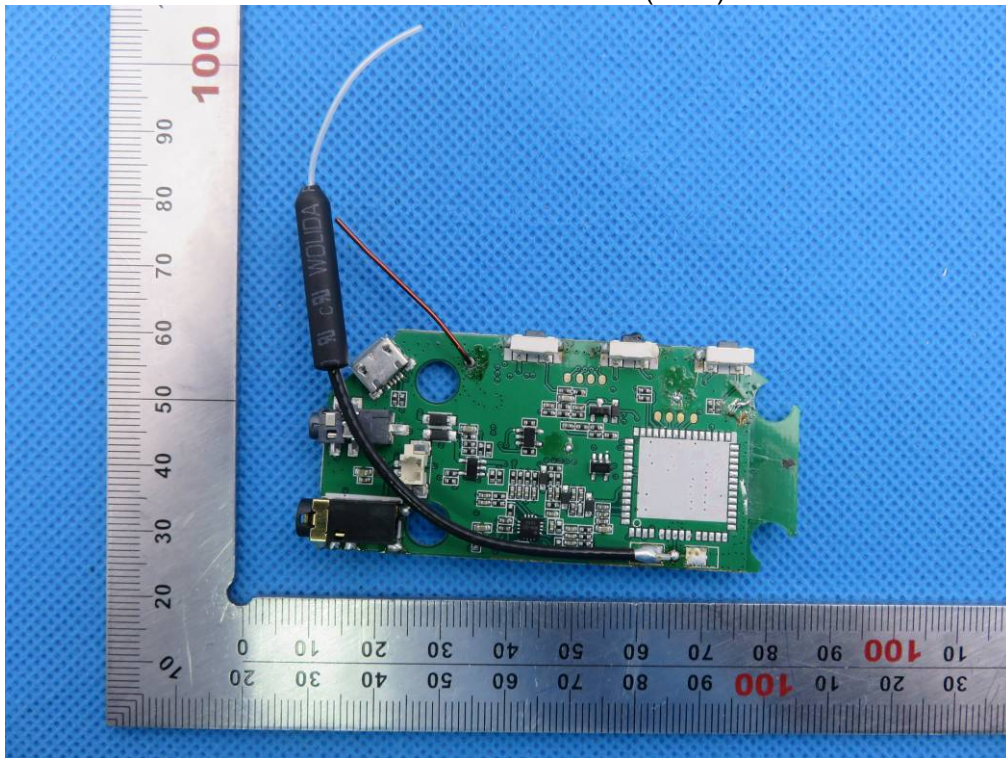

INTERNAL VIEW OF EUT-4(8635)

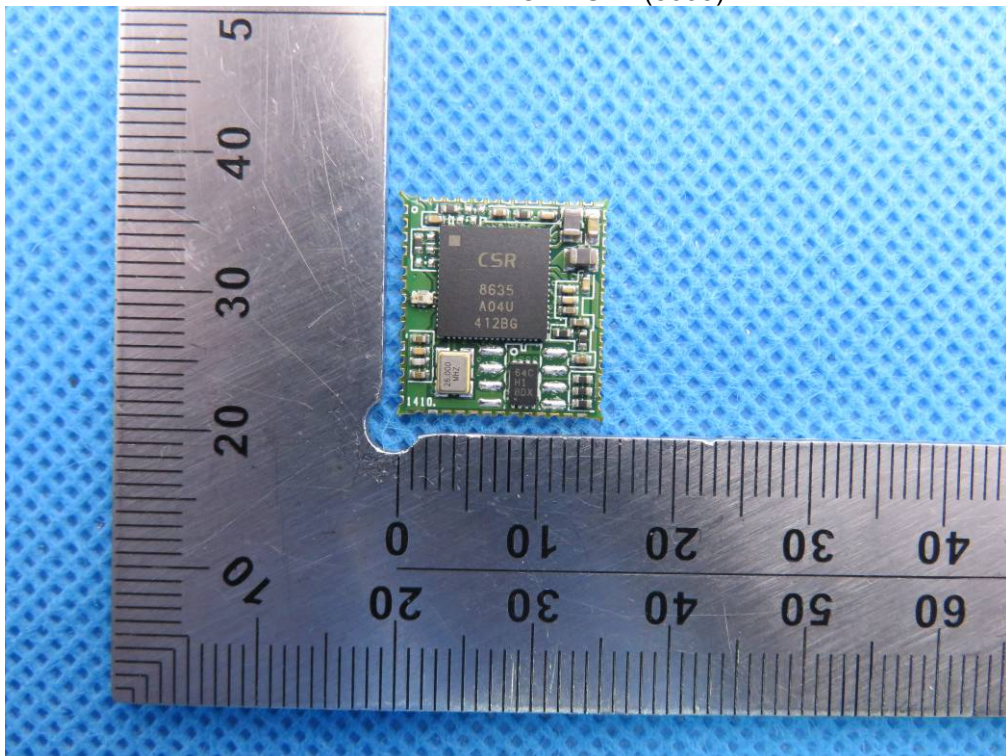

INTERNAL VIEW OF EUT-5(8635)

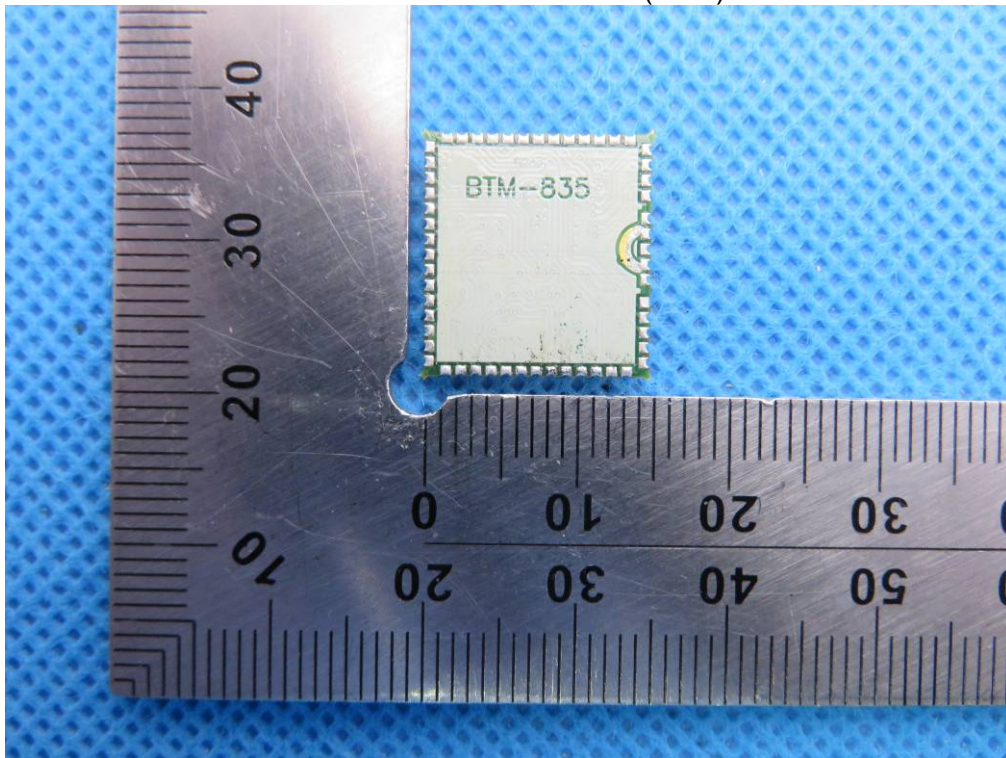

INTERNAL VIEW OF EUT-6(8670)

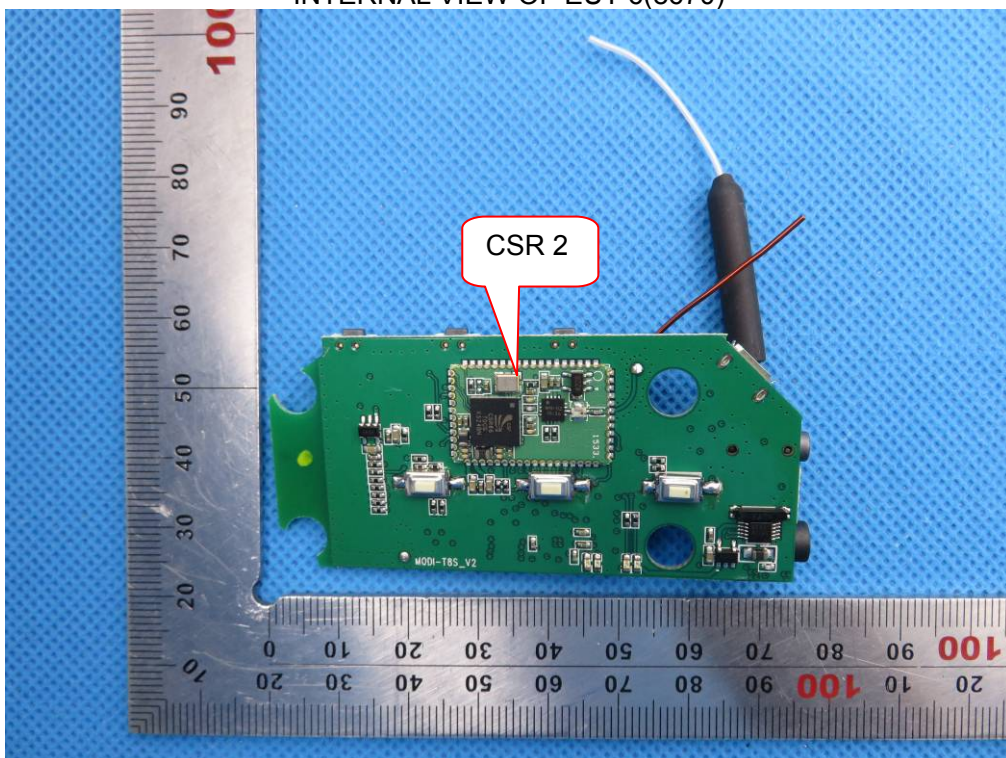

INTERNAL VIEW OF EUT-7(8670)

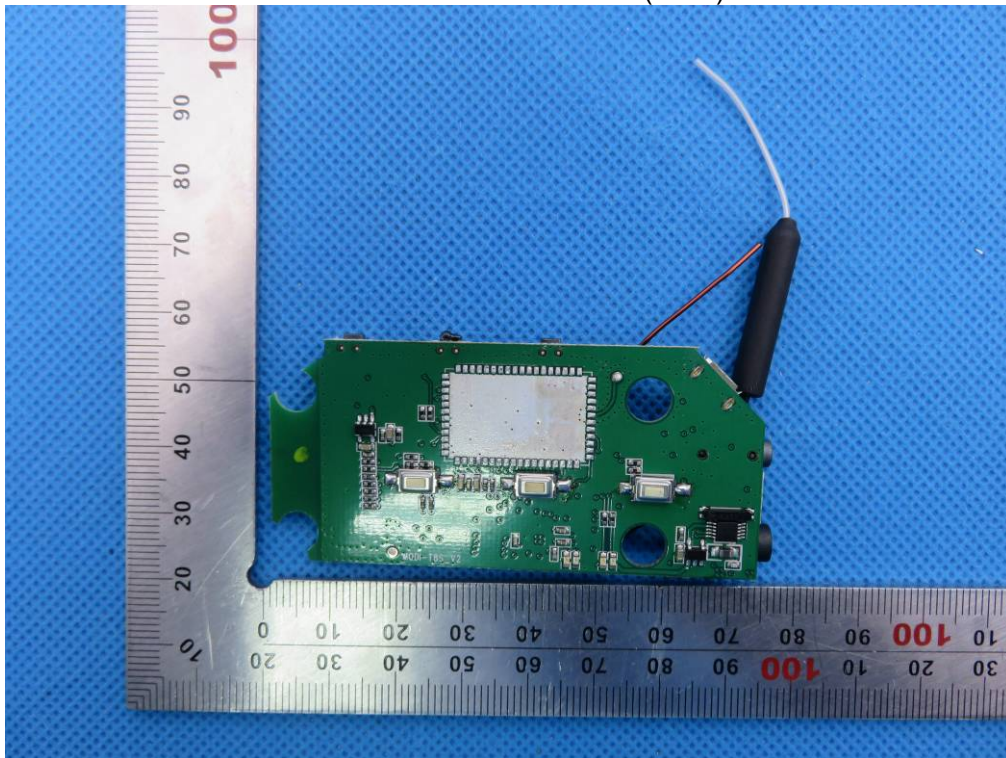

INTERNAL VIEW OF EUT-8(8670)

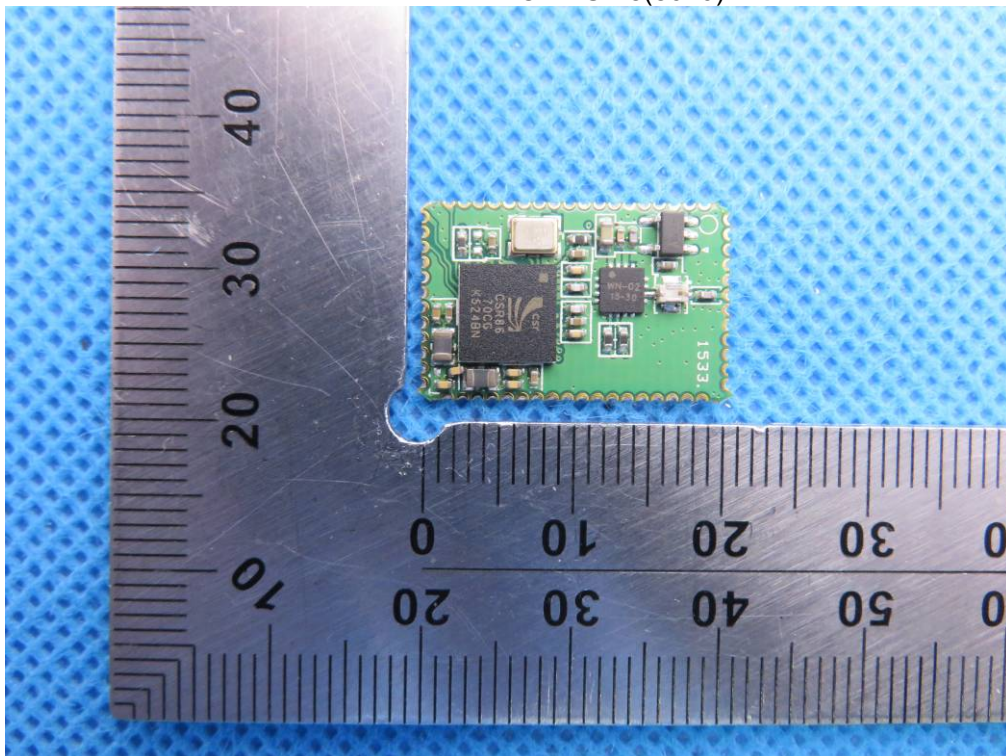

INTERNAL VIEW OF EUT-9(8670)

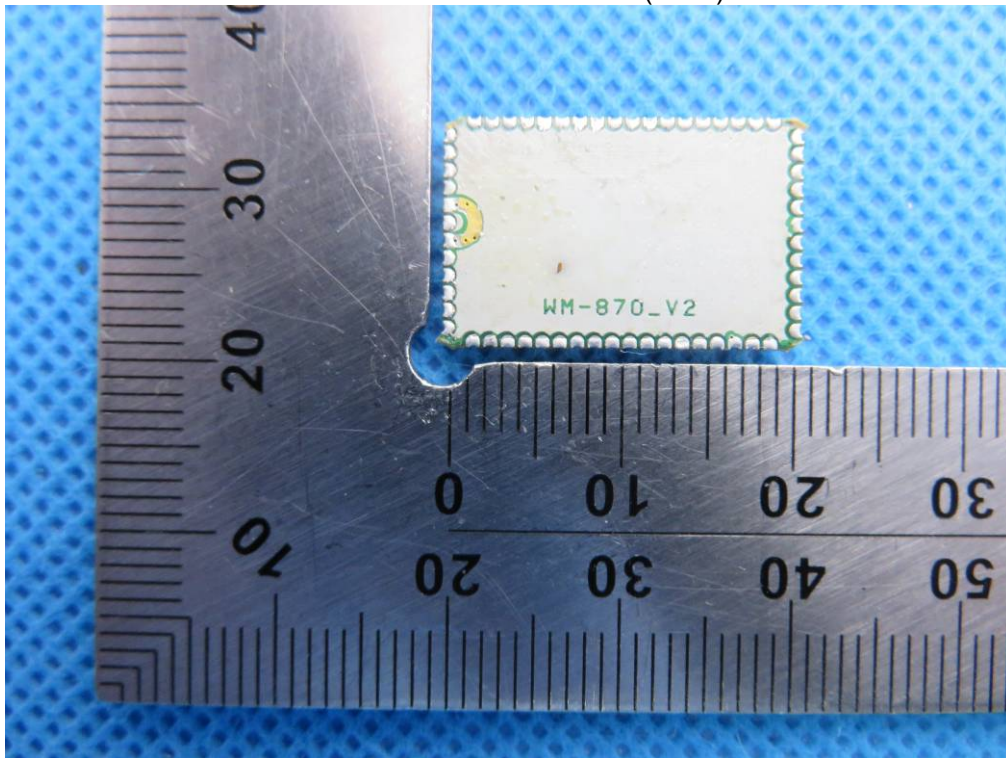

----END OF REPORT----