

Test Report

Report No. : MTi250515031-0104E1

Date of issue : 2025-08-20

Applicant : Guangzhou Havit Technology Co., Ltd.

Product : TRIO QI2 WIRELESS CHARGING STAND

Model(s) : W3037, N9VLT-WLC-TRIO-BK,
N9VLT-WLC-TRIO-WH

FCC ID : 2AI6I-W3037

Shenzhen Microtest Co., Ltd.

TEST REPORT



Report No.: MTi250515031-0104E1

Table of contents

1	General Description	4
1.1	Description of the EUT	4
1.2	Description of test modes	4
1.3	Environmental Conditions	6
1.4	Description of support units	6
1.5	Measurement uncertainty	6
2	Summary of Test Result	7
3	Test Facilities and accreditations	8
3.1	Test laboratory	8
4	List of test equipment	9
5	Evaluation Results (Evaluation)	10
5.1	Antenna requirement	10
6	Radio Spectrum Matter Test Results (RF)	11
6.1	Conducted Emission at AC power line	11
6.2	20dB Occupied Bandwidth	14
6.3	Emissions in frequency bands (below 30MHz)	21
6.4	Emissions in frequency bands (30MHz - 1GHz)	27
	Photographs of the test setup	31
	Photographs of the EUT	32

TEST REPORT

Report No.: MTi250515031-0104E1

Test Result Certification		
Applicant	Guangzhou Havit Technology Co., Ltd.	
Applicant Address	ROOM 1307, 13F, PHASE 2 B, C BUILDING OF POLY WORLD TRADE CENTER, NO.1000, XINGANG EAST ROAD, HAIZHU GUANGDONG China	
Manufacturer	Guangzhou Havit Technology Co., Ltd.	
Manufacturer Address	ROOM 1307, 13F, PHASE 2 B, C BUILDING OF POLY WORLD TRADE CENTER, NO.1000, XINGANG EAST ROAD, HAIZHU GUANGDONG China	
Product description		
Product name	TRIO QI2 WIRELESS CHARGING STAND	
Trademark	HAVIT	
Model name	W3037	
Series Model(s)	N9VLT-WLC-TRIO-BK, N9VLT-WLC-TRIO-WH	
Standards	47 CFR Part 15C	
Test Method	ANSI C63.10-2020	
Testing Information		
Date of test	2025-08-08 to 2025-08-20	
Test result	Pass	
Prepared by:	Maleah Deng	
Reviewed by:	David Lee	
Approved by:	Lewis Lian	

TEST REPORT

Report No.: MTi250515031-0104E1

1 General Description

1.1 Description of the EUT

Product name:	TRIO QI2 WIRELESS CHARGING STAND
Model name:	W3037
Series Model(s):	N9VLT-WLC-TRIO-BK, N9VLT-WLC-TRIO-WH
Model difference:	All the models are the same circuit and module, except the model name and color.
Electrical rating:	Input: DC 9V/3A Wireless Output: Phone: 15W(compatible with 7.5W and 5W); Watch: 2.5W; Earbuds: 5W(Max)
Accessories:	Cable: USB-C to USB-C cable 95cm*1
Hardware version:	V1.0
Software version:	V1.0
Test sample(s) number:	MTi250515031-01-R002
RF specification	
Operating frequency range:	Coil 1 (Phone): 115-205kHz(5W,7.5W, 15W EPP); 360kHz(15W MPP) Coil 2 (Earbuds): 115-205kHz Coil 3 (Watch): 115-205kHz(Samsung Watch) & 300-350kHz(Apple Watch)
Modulation type:	ASK
Antenna(s) type:	Coil Antenna

1.2 Description of test modes

No.	Emission test modes
Mode1	Wireless output(Phone(5W)+Earbuds(5W)+Apple Watch(2.5W))
Mode2	Wireless output(Phone(7.5W)+Earbuds(5W)+Apple Watch(2.5W))
Mode3	Wireless output(Phone(15W EPP)+Earbuds(5W)+Apple Watch(2.5W))
Mode4	Wireless output(Phone(15W MPP)+Earbuds(5W)+Apple Watch(2.5W))
Mode5	Wireless output(Phone(5W)+Earbuds(5W)+Samsung Watch(2.5W))
Mode6	Wireless output(Phone(7.5W)+Earbuds(5W)+Samsung Watch(2.5W))
Mode7	Wireless output(Phone(15W EPP)+Earbuds(5W)+Samsung Watch(2.5W))
Mode8	Wireless output(Phone(15W MPP)+Earbuds(5W)+Samsung Watch(2.5W))
Mode9	Wireless output(Phone(5W)+Earbuds(5W))
Mode10	Wireless output(Phone(7.5W)+Earbuds(5W))
Mode11	Wireless output(Phone(15W EPP)+Earbuds(5W))
Mode12	Wireless output(Phone(15W MPP)+Earbuds(5W))
Mode13	Wireless output(Phone(5W)+Apple Watch(2.5W))

TEST REPORT

Report No.: MTi250515031-0104E1

Mode14	Wireless output(Phone(7.5W)+Apple Watch(2.5W))
Mode15	Wireless output(Phone(15W EPP)+Apple Watch(2.5W))
Mode16	Wireless output(Phone(15W MPP)+Apple Watch(2.5W))
Mode17	Wireless output(Phone(5W)+Samsung Watch(2.5W))
Mode18	Wireless output(Phone(7.5W)+Samsung Watch(2.5W))
Mode19	Wireless output(Phone(15W EPP)+Samsung Watch(2.5W))
Mode20	Wireless output(Phone(15W MPP)+Samsung Watch(2.5W))
Mode21	Wireless Output(Airpods(5W)+Apple Watch(2.5W))
Mode22	Wireless Output(Airpods(5W)+Samsung Watch(2.5W))
Mode23	Wireless output(Phone(5W))
Mode24	Wireless output(Phone(7.5W))
Mode25	Wireless output(Phone(15W EPP))
Mode26	Wireless output(Phone(15W MPP))
Mode27	Wireless Output(Earbuds(5W))
Mode28	Wireless Output(Apple Watch(2.5W))
Mode29	Wireless Output(Samsung Watch(2.5W))
Mode30	stand by

TEST REPORT

Report No.: MTi250515031-0104E1

1.3 Environmental Conditions

During the measurement the environmental conditions were within the listed ranges:

Temperature:	15°C ~ 35°C
Humidity:	20% RH ~ 75% RH
Atmospheric pressure:	98 kPa ~ 101 kPa

1.4 Description of support units

The EUT has been tested as an independent unit together with other necessary accessories or support units. The following support units or accessories were used to form a representative test configuration during the tests.

Support equipment list

Description	Model	Serial No.	Manufacturer
Apple Watch	Apple Watch SE	FH7PP6BAG91J6	Apple
wireless charging load	YBZ3.0	/	YBZ
airpods	airpods 3	/	apple
HUAWEI QUICK CHARGE(65W)	HW-200200ZP1	JN67LSN7N03451	HUAWEI
wireless charging load	YBZ2.1	/	YBZ
Watch	Galaxy Watch 5	R32T5467890	Samsung

Support cable list

Description	Length (m)	From	To
/	/	/	/

1.5 Measurement uncertainty

Measurement	Uncertainty
Conducted emissions (AMN 150kHz~30MHz)	±3.1dB
Occupied channel bandwidth	±3 %
Radiated spurious emissions (9kHz~30MHz)	±4.3dB
Radiated spurious emissions (30MHz~1GHz)	±4.7dB
Temperature	±1 °C
Humidity	± 5 %

This uncertainty represents an expanded uncertainty expressed at approximately the 95% confidence level using a coverage factor of k=2.

TEST REPORT

Report No.: MTi250515031-0104E1

2 Summary of Test Result

No.	Item	Standard	Requirement	Result
1	Antenna requirement	47 CFR Part 15C	47 CFR Part 15.203	Pass
2	Conducted Emission at AC power line	47 CFR Part 15C	47 CFR Part 15.207(a)	Pass
3	20dB Occupied Bandwidth	47 CFR Part 15C	47 CFR Part 15.215(c)	Pass
4	Emissions in frequency bands (below 30MHz)	47 CFR Part 15C	47 CFR Part 15.209	Pass
5	Emissions in frequency bands (30MHz - 1GHz)	47 CFR Part 15C	47 CFR Part 15.209	Pass

TEST REPORT

Report No.: MTi250515031-0104E1

3 Test Facilities and accreditations

3.1 Test laboratory

Test laboratory:	Shenzhen Microtest Co., Ltd.
Test site location:	101, No.7, Zone 2, Xinxing Industrial Park, Fuhai Avenue, Xinhe Community, Fuhai Street, Bao'an District, Shenzhen, Guangdong, China
Telephone:	(86-755)88850135
Fax:	(86-755)88850136
CNAS Registration No.:	CNAS L5868
FCC Registration No.:	448573
IC Registration No.:	21760
CABID:	CN0093

TEST REPORT

Report No.: MTi250515031-0104E1

4 List of test equipment

No.	Equipment	Manufacturer	Model	Serial No.	Cal. date	Cal. Due
Conducted Emission at AC power line						
1	EMI Test Receiver	Rohde&schwarz	ESCi3	101368	2025-03-14	2026-03-13
2	Artificial mains network	Schwarzbeck	NSLK 8127	183	2025-03-18	2026-03-17
3	Artificial Mains Network	Rohde & Schwarz	ESH2-Z5	100263	2025-03-18	2026-03-17
20dB Occupied Bandwidth						
1	Wideband Radio Communication Tester	Rohde&schwarz	CMW500	149155	2025-03-18	2026-03-17
2	ESG Series Analog Ssignal Generator	Agilent	E4421B	GB40051240	2025-03-14	2026-03-13
3	PXA Signal Analyzer	Agilent	N9030A	MY51350296	2025-03-14	2026-03-13
4	Synthesized Sweeper	Agilent	83752A	3610A01957	2025-03-14	2026-03-13
5	MXA Signal Analyzer	Agilent	N9020A	MY50143483	2025-03-14	2026-03-13
6	RF Control Unit	Tonscend	JS0806-1	19D8060152	2025-03-18	2026-03-17
7	Band Reject Filter Group	Tonscend	JS0806-F	19D8060160	2025-03-14	2026-03-13
8	ESG Vector Signal Generator	Agilent	N5182A	MY50143762	2025-03-14	2026-03-13
9	DC Power Supply	Agilent	E3632A	MY40027695	2025-03-18	2026-03-17
Emissions in frequency bands (below 30MHz)						
1	EMI Test Receiver	Rohde&schwarz	ESCi7	101166	2025-03-14	2026-03-13
2	Active Loop Antenna	Schwarzbeck	FMZB 1519 B	00066	2024-03-23	2026-03-22
3	Amplifier	Hewlett-Packard	8447F	3113A06184	2025-03-18	2026-03-17
Emissions in frequency bands (30MHz - 1GHz)						
1	EMI Test Receiver	Rohde&schwarz	ESCi7	101166	2025-03-14	2026-03-13
2	TRILOG Broadband Antenna	schwarabeck	VULB 9163	9163-1338	2025-05-23	2027-05-22
3	Active Loop Antenna	Schwarzbeck	FMZB 1519 B	00066	2024-03-23	2026-03-22
4	Amplifier	Hewlett-Packard	8447F	3113A06184	2025-03-18	2026-03-17

TEST REPORT

Report No.: MTi250515031-0104E1

5 Evaluation Results (Evaluation)

5.1 Antenna requirement

Test Requirement:	Refer to 47 CFR Part 15.203, an intentional radiator shall be designed to ensure that no antenna other than that furnished by the responsible party shall be used with the device. The use of a permanently attached antenna or of an antenna that uses a unique coupling to the intentional radiator shall be considered sufficient to comply with the provisions of this section.
-------------------	---

5.1.1 Conclusion:

The antenna of the EUT is permanently attached.
The EUT complies with the requirement of FCC PART 15.203.

TEST REPORT

Report No.: MTi250515031-0104E1

6 Radio Spectrum Matter Test Results (RF)

6.1 Conducted Emission at AC power line

Test Requirement:	Except as shown in paragraphs (b) and (c) of this section, for an intentional radiator that is designed to be connected to the public utility (AC) power line, the radio frequency voltage that is conducted back onto the AC power line on any frequency or frequencies, within the band 150 kHz to 30 MHz, shall not exceed the limits in the following table, as measured using a 50 μ H/50 ohms line impedance stabilization network (LISN).		
Test Limit:	Frequency of emission (MHz)	Conducted limit (dB μ V)	
		Quasi-peak	Average
	0.15-0.5	66 to 56*	56 to 46*
	0.5-5	56	46
	5-30	60	50
	*Decreases with the logarithm of the frequency.		
Test Method:	ANSI C63.10-2020 section 6.2		
Procedure:	Refer to ANSI C63.10-2020 section 6.2, standard test method for ac power-line conducted emissions from unlicensed wireless devices		

6.1.1 E.U.T. Operation:

Operating Environment:			
Temperature:	26 °C	Humidity:	42 %
		Atmospheric Pressure:	100 kPa
Pre test mode:	Mode1, Mode2, Mode3, Mode4, Mode5, Mode6, Mode7, Mode8, Mode9, Mode10, Mode11, Mode12, Mode13, Mode14, Mode15, Mode16, Mode17, Mode18, Mode19, Mode20, Mode21, Mode22, Mode23, Mode24, Mode25, Mode26, Mode27, Mode28, Mode29, Mode30		
Final test mode:	All of the listed pre-test mode were tested, only the data of the worst mode (Mode4) is recorded in the report		

6.1.2 Test Setup Diagram:

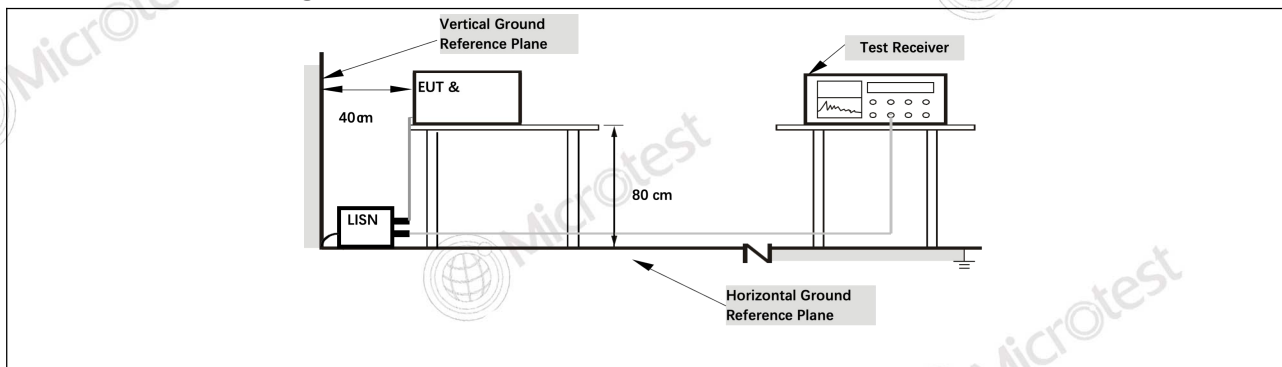

TEST REPORT

Report No.: MTi250515031-0104E1

6.1.3 Test Data:

Mode4 / Line: Line

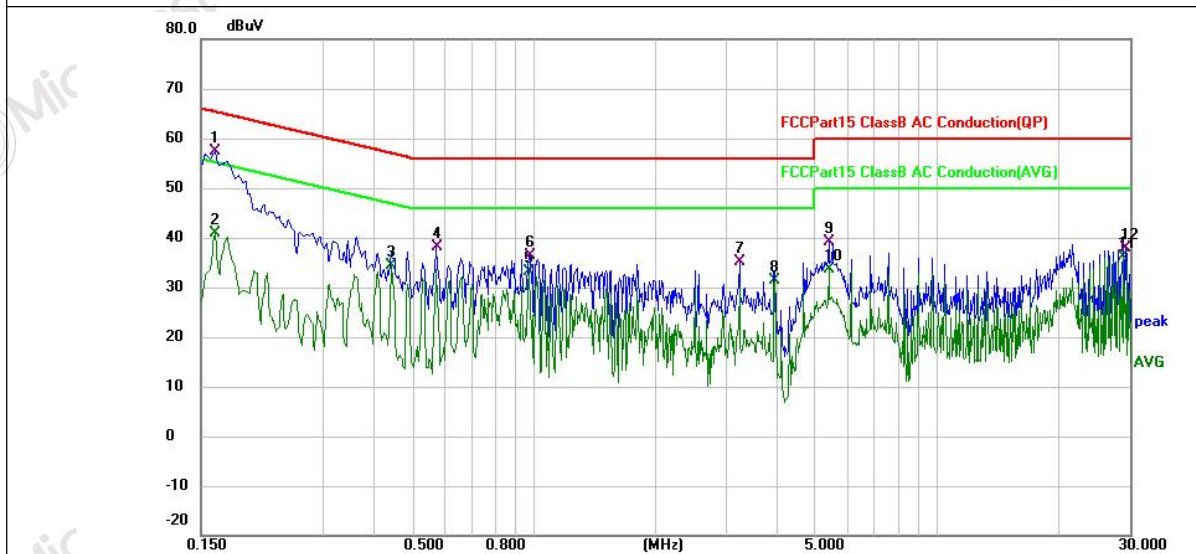

No.	Mk.	Freq.	Reading Level	Correct Factor	Measurement	Limit	Over	Detector	Comment
		MHz	dBuV	dB	dBuV	dBuV	dB		
1	*	0.1620	47.14	10.17	57.31	65.36	-8.05	QP	
2		0.1620	30.81	10.17	40.98	55.36	-14.38	AVG	
3		0.4420	24.10	10.20	34.30	47.02	-12.72	AVG	
4		0.5740	28.05	10.19	38.24	56.00	-17.76	QP	
5		0.9700	23.05	10.19	33.24	46.00	-12.76	AVG	
6		0.9740	26.09	10.19	36.28	56.00	-19.72	QP	
7		3.2420	24.91	10.23	35.14	56.00	-20.86	QP	
8		3.9660	21.22	10.24	31.46	46.00	-14.54	AVG	
9		5.4059	28.87	10.27	39.14	60.00	-20.86	QP	
10		5.4059	23.45	10.27	33.72	50.00	-16.28	AVG	
11		28.8300	25.30	10.71	36.01	50.00	-13.99	AVG	
12		29.3580	27.14	10.72	37.86	60.00	-22.14	QP	

TEST REPORT

Report No.: MTi250515031-0104E1

Mode4 / Line: Neutral

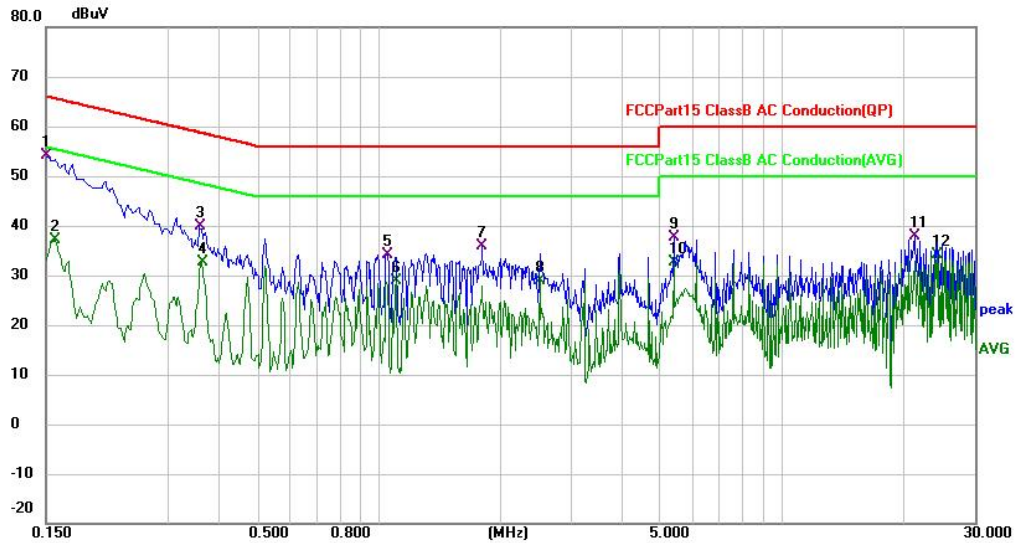

No.	Mk.	Freq. MHz	Reading Level dBuV	Correct Factor dB	Measure- ment dBuV	Limit dBuV	Over dB	Detector	Comment
1	*	0.1500	44.03	10.19	54.22	66.00	-11.78	QP	
2		0.1580	26.86	10.19	37.05	55.57	-18.52	AVG	
3		0.3580	29.68	10.20	39.88	58.77	-18.89	QP	
4		0.3620	22.53	10.20	32.73	48.68	-15.95	AVG	
5		1.0500	24.03	10.20	34.23	56.00	-21.77	QP	
6		1.1019	18.60	10.20	28.80	46.00	-17.20	AVG	
7		1.8020	25.57	10.22	35.79	56.00	-20.21	QP	
8		2.5220	18.56	10.23	28.79	46.00	-17.21	AVG	
9		5.4060	27.24	10.27	37.51	60.00	-22.49	QP	
10		5.4060	22.41	10.27	32.68	50.00	-17.32	AVG	
11		21.2620	27.23	10.56	37.79	60.00	-22.21	QP	
12		24.1460	23.53	10.62	34.15	50.00	-15.85	AVG	

TEST REPORT

Report No.: MTi250515031-0104E1

6.2 20dB Occupied Bandwidth

Test Requirement:	47 CFR Part 15.215(c)
Test Limit:	Refer to 47 CFR 15.215(c), intentional radiators operating under the alternative provisions to the general emission limits, as contained in §§ 15.217 through 15.257 and in subpart E of this part, must be designed to ensure that the 20 dB bandwidth of the emission, or whatever bandwidth may otherwise be specified in the specific rule section under which the equipment operates, is contained within the frequency band designated in the rule section under which the equipment is operated.
Test Method:	ANSI C63.10-2020, section 6.9.2
Procedure:	<p>a) The spectrum analyzer center frequency is set to the nominal EUT channel center frequency. The span range for the EMI receiver or spectrum analyzer shall be between two times and five times the OBW.</p> <p>b) The nominal IF filter bandwidth (3 dB RBW) shall be in the range of 1% to 5% of the OBW and video bandwidth (VBW) shall be approximately three times RBW, unless otherwise specified by the applicable requirement.</p> <p>c) Set the reference level of the instrument as required, keeping the signal from exceeding the maximum input mixer level for linear operation. In general, the peak of the spectral envelope shall be more than $[10 \log (OBW/RBW)]$ below the reference level. Specific guidance is given in 4.1.5.2.</p> <p>d) Steps a) through c) might require iteration to adjust within the specified tolerances.</p> <p>e) The dynamic range of the instrument at the selected RBW shall be more than 10 dB below the target “-xx dB down” requirement; that is, if the requirement calls for measuring the -20 dB OBW, the instrument noise floor at the selected RBW shall be at least 30 dB below the reference value.</p> <p>f) Set detection mode to peak and trace mode to max hold.</p> <p>g) Determine the reference value: Set the EUT to transmit an unmodulated carrier or modulated signal, as applicable. Allow the trace to stabilize. Set the spectrum analyzer marker to the highest level of the displayed trace (this is the reference value).</p> <p>h) Determine the “-xx dB down amplitude” using $[(\text{reference value}) - xx]$. Alternatively, this calculation may be made by using the marker-delta function of the instrument.</p> <p>i) If the reference value is determined by an unmodulated carrier, then turn the EUT modulation ON, and either clear the existing trace or start a new trace on the spectrum analyzer and allow the new trace to stabilize. Otherwise, the trace from step g) shall be used for step j).</p> <p>j) Place two markers, one at the lowest frequency and the other at the highest frequency of the envelope of the spectral display, such that each marker is at or slightly below the “-xx dB down amplitude” determined in step h). If a marker is below this “-xx dB down amplitude” value, then it shall be as close as possible to this value. The occupied bandwidth is the frequency difference between the two markers. Alternatively, set a marker at the lowest frequency of the envelope of the spectral display, such that the marker is at or slightly below the “-xx dB down amplitude” determined in step h). Reset the marker-delta function and move the marker to the other side of the emission until the delta marker amplitude is at the same level as the reference marker amplitude. The marker-delta frequency reading at this point is the specified emission bandwidth.</p> <p>k) The occupied bandwidth shall be reported by providing plot(s) of the</p>

TEST REPORT

Report No.: MTi250515031-0104E1

	measuring instrument display; the plot axes and the scale units per division shall be clearly labeled. Tabular data may be reported in addition to the plot(s).
--	---

6.2.1 E.U.T. Operation:

Operating Environment:					
Temperature:	19.3 °C	Humidity:	45.8 %	Atmospheric Pressure:	100 kPa
Pre test mode:	Mode1, Mode2, Mode3, Mode4, Mode5, Mode6, Mode7, Mode8, Mode9, Mode10, Mode11, Mode12, Mode13, Mode14, Mode15, Mode16, Mode17, Mode18, Mode19, Mode20, Mode21, Mode22, Mode23, Mode24, Mode25, Mode26, Mode27, Mode28, Mode29, Mode30				
Final test mode:	All of the listed pre-test mode were tested, only the data of the worst mode (Mode25, Mode26, Mode27, Mode28, Mode29) is recorded in the report				

6.2.2 Test Setup Diagram:

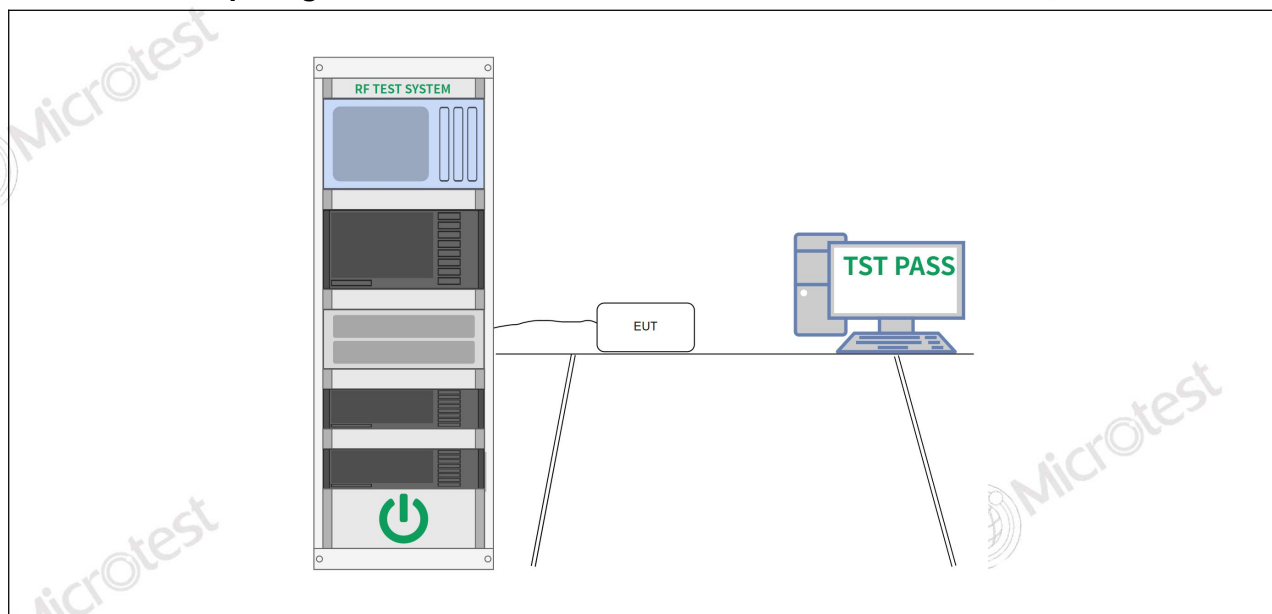

TEST REPORT

Report No.: MTi250515031-0104E1

6.2.3 Test Data:

Note: Because the measured signal is CW-like, adjusting the RBW per C63.10 would not be practical since measurement bandwidth will always follow the RBW. The RBW is set to 300 Hz to perform the occupied bandwidth test.

Coil 1(15W EPP)

Frequency kHz	20 dB occupied bandwidth Hz	99% occupied bandwidth Hz
133.23	748	635

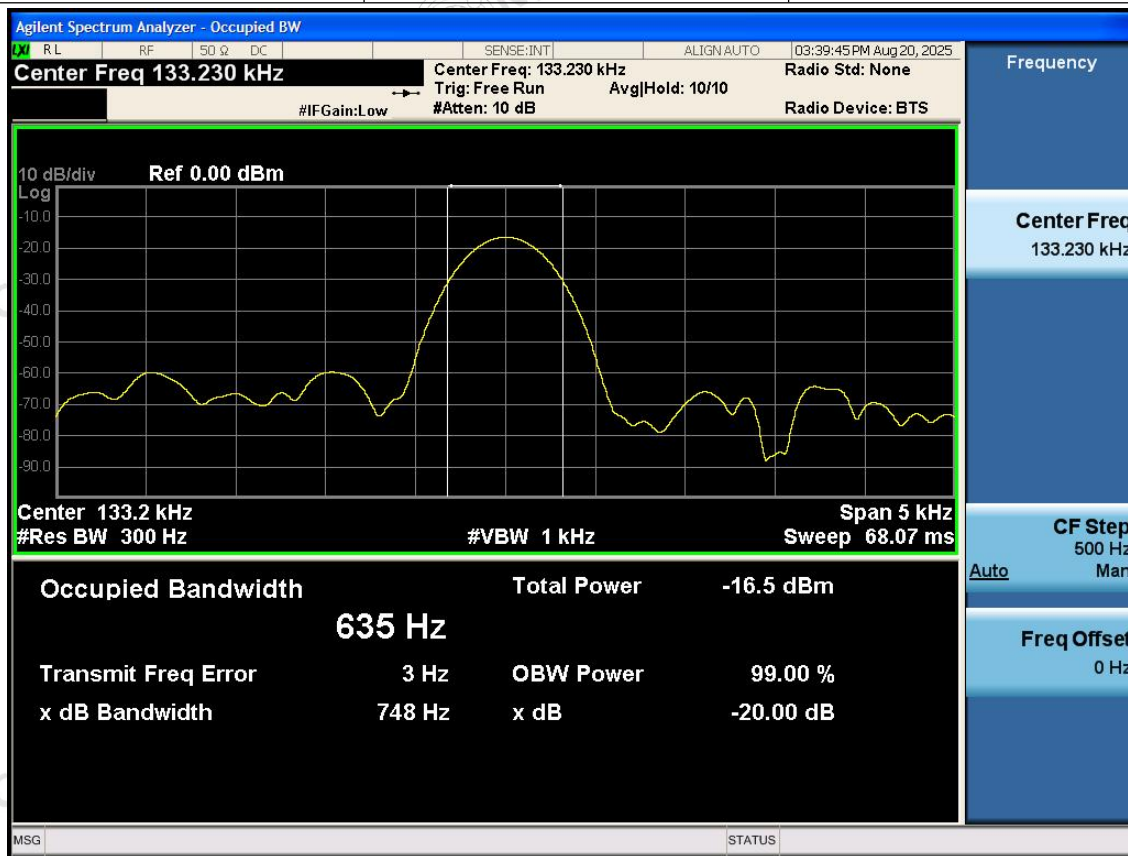

TEST REPORT

Report No.: MTi250515031-0104E1

Note: Because the measured signal is CW-like, adjusting the RBW per C63.10 would not be practical since measurement bandwidth will always follow the RBW. The RBW is set to 300 Hz to perform the occupied bandwidth test.

Coil 1(15W MPP)

Frequency kHz	20 dB occupied bandwidth Hz	99% occupied bandwidth Hz
360	758	719



TEST REPORT

Report No.: MTi250515031-0104E1

Note: Because the measured signal is CW-like, adjusting the RBW per C63.10 would not be practical since measurement bandwidth will always follow the RBW. The RBW is set to 300 Hz to perform the occupied bandwidth test.

Coil 2

Frequency kHz	20 dB occupied bandwidth Hz	99% occupied bandwidth Hz
156.86	749	639

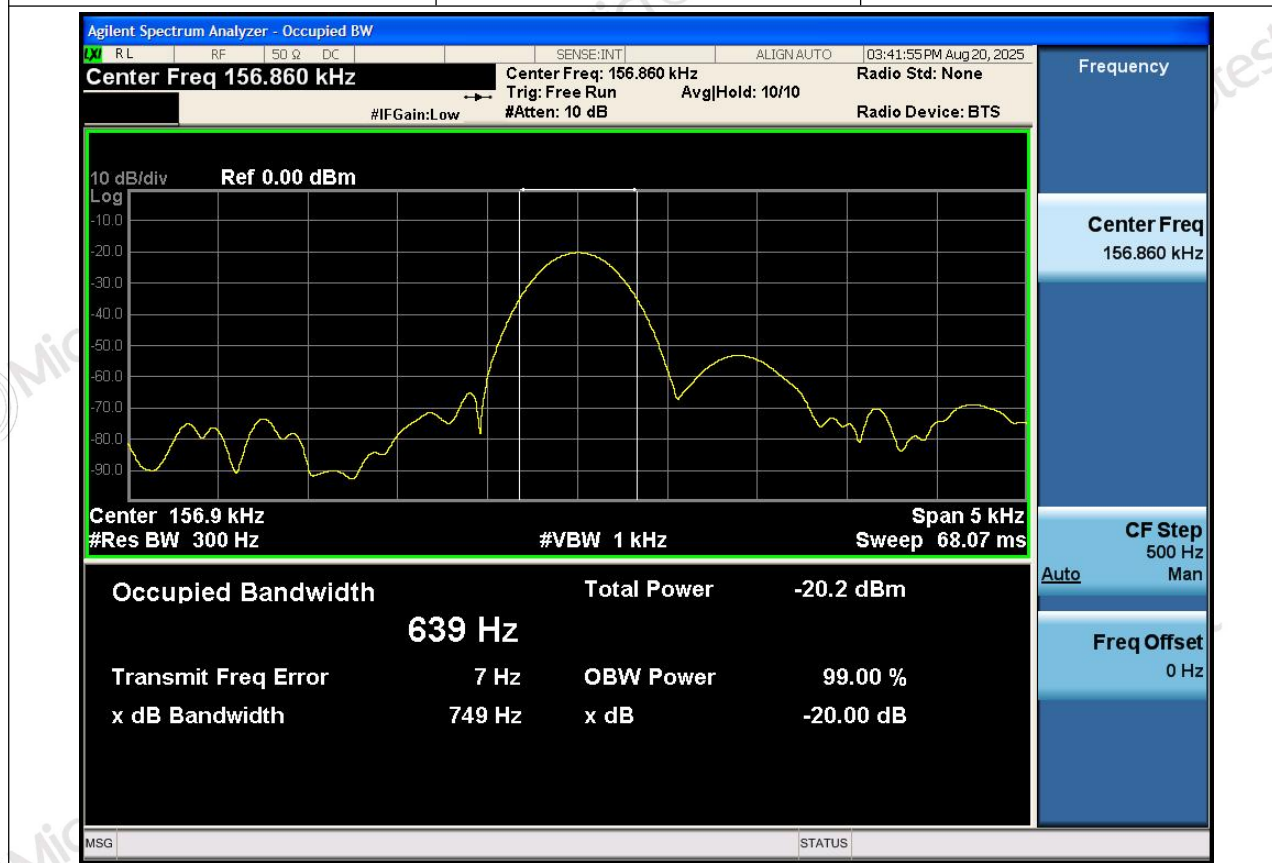

TEST REPORT

Report No.: MTi250515031-0104E1

Note: Because the measured signal is CW-like, adjusting the RBW per C63.10 would not be practical since measurement bandwidth will always follow the RBW. The RBW is set to 300 Hz to perform the occupied bandwidth test.

Coil 3(Apple Watch)

Frequency kHz	20 dB occupied bandwidth Hz	99% occupied bandwidth Hz
318.91	768	657

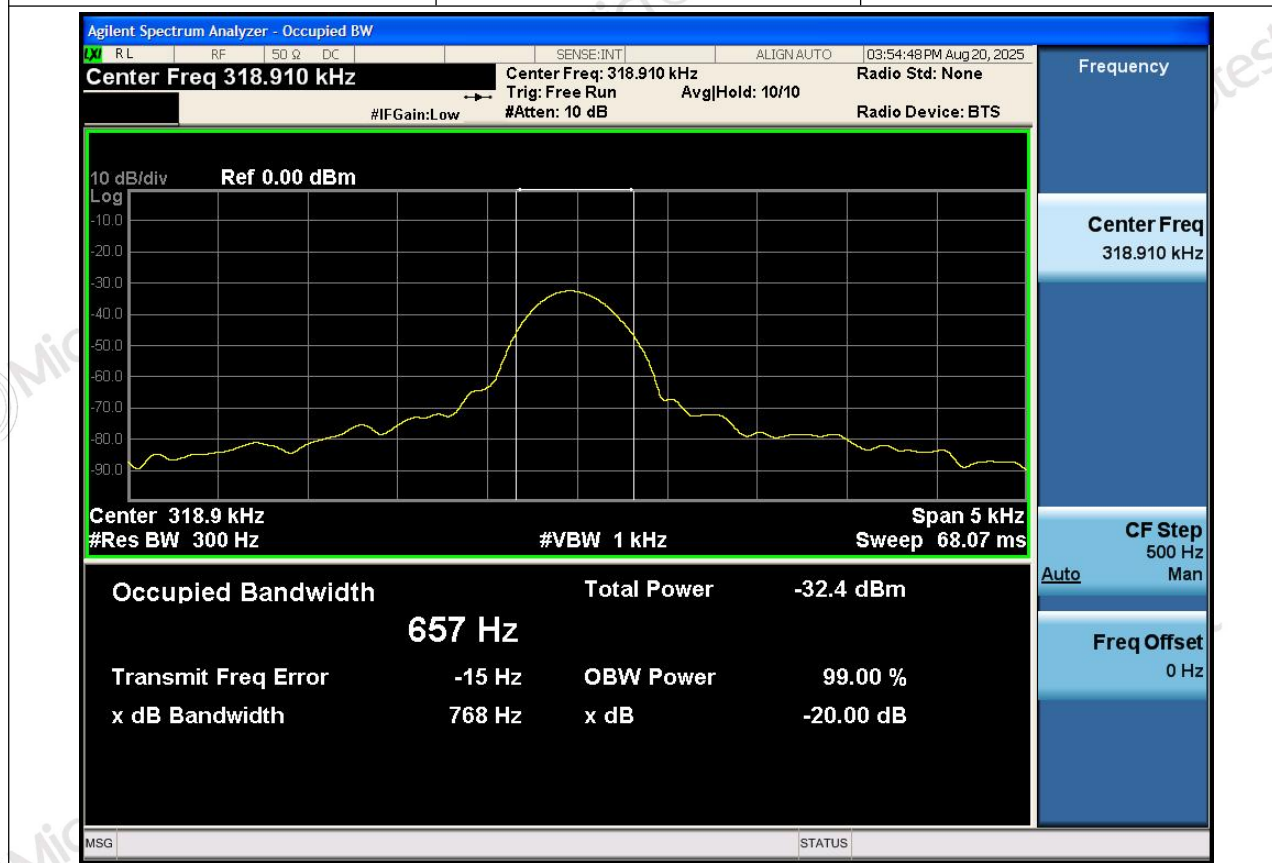

TEST REPORT

Report No.: MTi250515031-0104E1

Note: Because the measured signal is CW-like, adjusting the RBW per C63.10 would not be practical since measurement bandwidth will always follow the RBW. The RBW is set to 300 Hz to perform the occupied bandwidth test.

Coil 3(Samsung Watch)

Frequency kHz	20 dB occupied bandwidth Hz	99% occupied bandwidth Hz
157.67	768	665

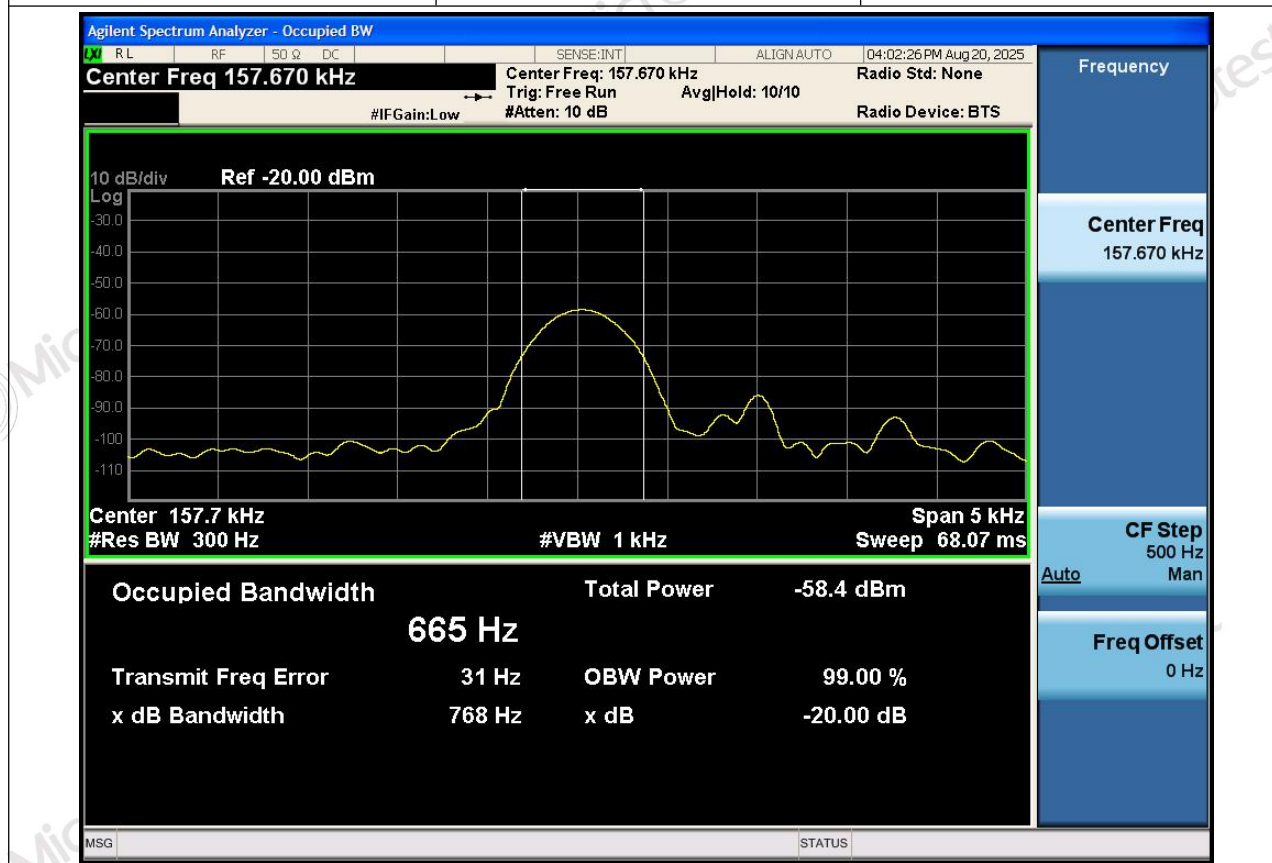

TEST REPORT

Report No.: MTi250515031-0104E1

6.3 Emissions in frequency bands (below 30MHz)

Test Requirement:	47 CFR Part 15.209		
Test Limit:	Frequency (MHz)	Field strength (microvolts/meter)	Measurement distance (meters)
	0.009-0.490	2400/F(kHz)	300
	0.490-1.705	24000/F(kHz)	30
	1.705-30.0	30	30
	30-88	100 **	3
	88-216	150 **	3
	216-960	200 **	3
	Above 960	500	3
<p>** Except as provided in paragraph (g), fundamental emissions from intentional radiators operating under this section shall not be located in the frequency bands 54-72 MHz, 76-88 MHz, 174-216 MHz or 470-806 MHz. However, operation within these frequency bands is permitted under other sections of this part, e.g., §§ 15.231 and 15.241.</p> <p>In the emission table above, the tighter limit applies at the band edges. The emission limits shown in the above table are based on measurements employing a CISPR quasi-peak detector except for the frequency bands 9–90 kHz, 110–490 kHz and above 1000 MHz. Radiated emission limits in these three bands are based on measurements employing an average detector. As shown in § 15.35(b), for frequencies above 1000 MHz, the field strength limits in paragraphs (a) and (b) of this section are based on average limits. However, the peak field strength of any emission shall not exceed the maximum permitted average limits specified above by more than 20 dB under any condition of modulation. For point-to-point operation under paragraph (b) of this section, the peak field strength shall not exceed 2500 millivolts/meter at 3 meters along the antenna azimuth.</p>			
Test Method:	ANSI C63.10-2020 section 6.4		
Procedure:	ANSI C63.10-2020 section 6.4		

6.3.1 E.U.T. Operation:

Operating Environment:					
Temperature:	21 °C	Humidity:	53 %	Atmospheric Pressure:	101 kPa
Pre test mode:	Mode1, Mode2, Mode3, Mode4, Mode5, Mode6, Mode7, Mode8, Mode9, Mode10, Mode11, Mode12, Mode13, Mode14, Mode15, Mode16, Mode17, Mode18, Mode19, Mode20, Mode21, Mode22, Mode23, Mode24, Mode25, Mode26, Mode27, Mode28, Mode29, Mode30				
Final test mode:	All of the listed pre-test mode were tested, only the data of the worst mode (Mode4, Mode7) is recorded in the report				

TEST REPORT

Report No.: MTi250515031-0104E1

6.3.2 Test Setup Diagram:

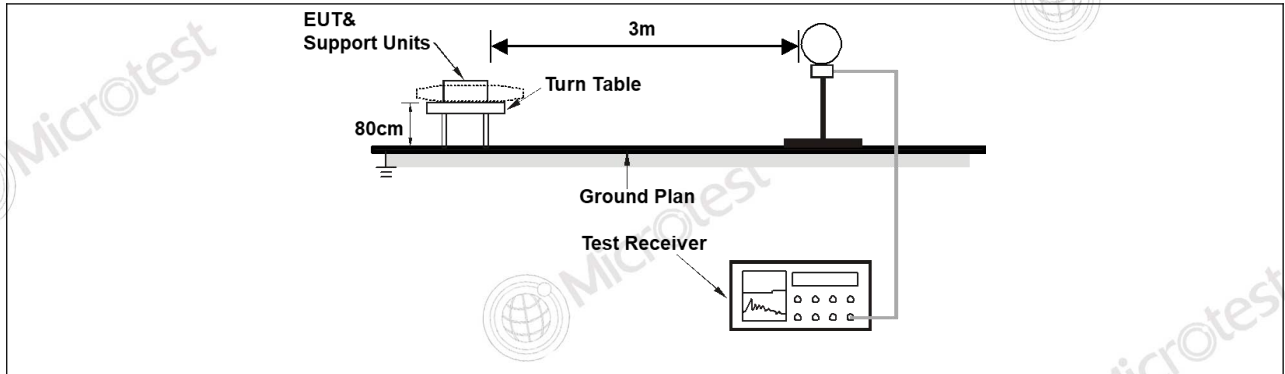

TEST REPORT

Report No.: MTi250515031-0104E1

6.3.3 Test Data:

Mode4 / EUT direction: X axis

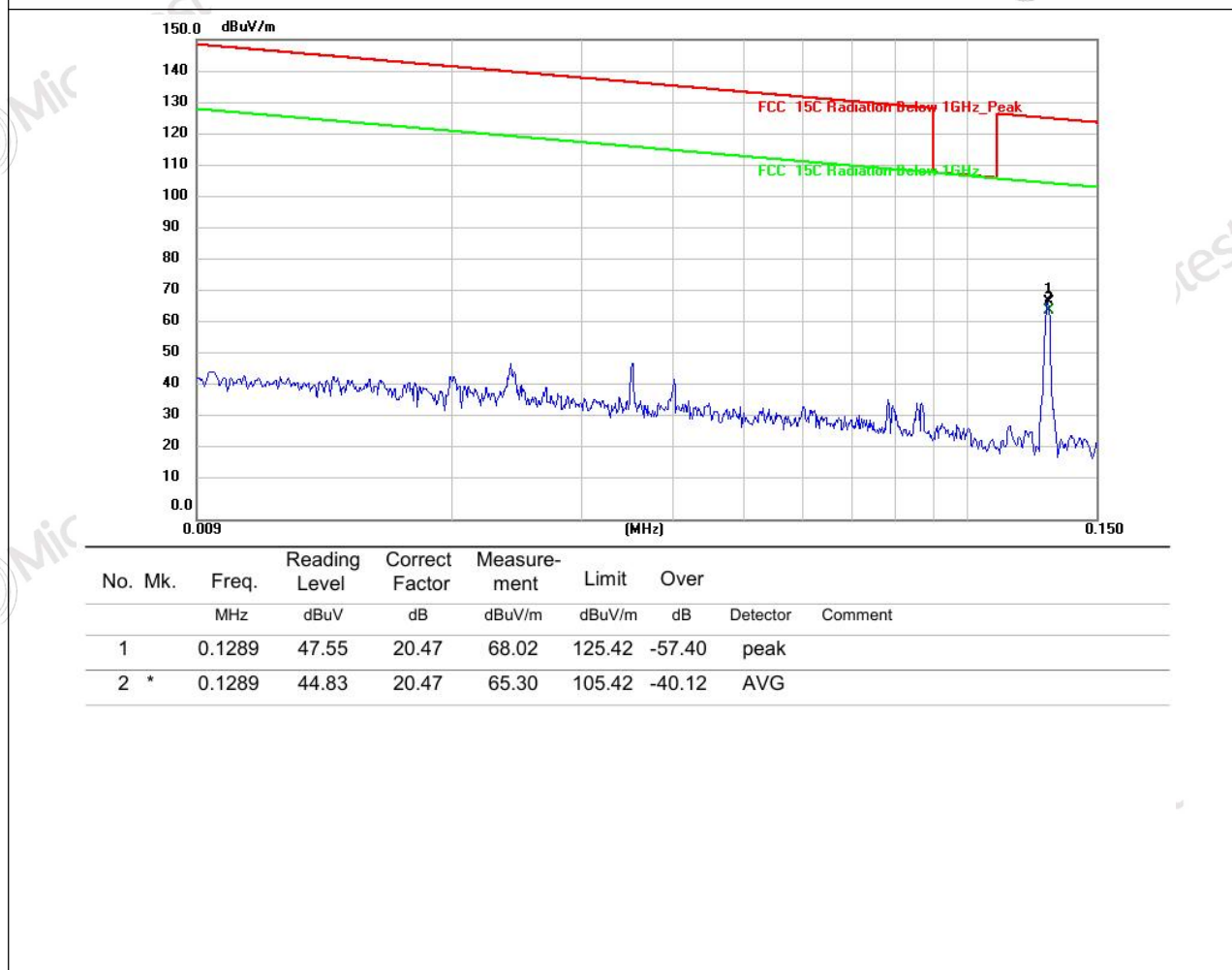

TEST REPORT

Report No.: MTi250515031-0104E1

Mode4 / EUT direction: X axis

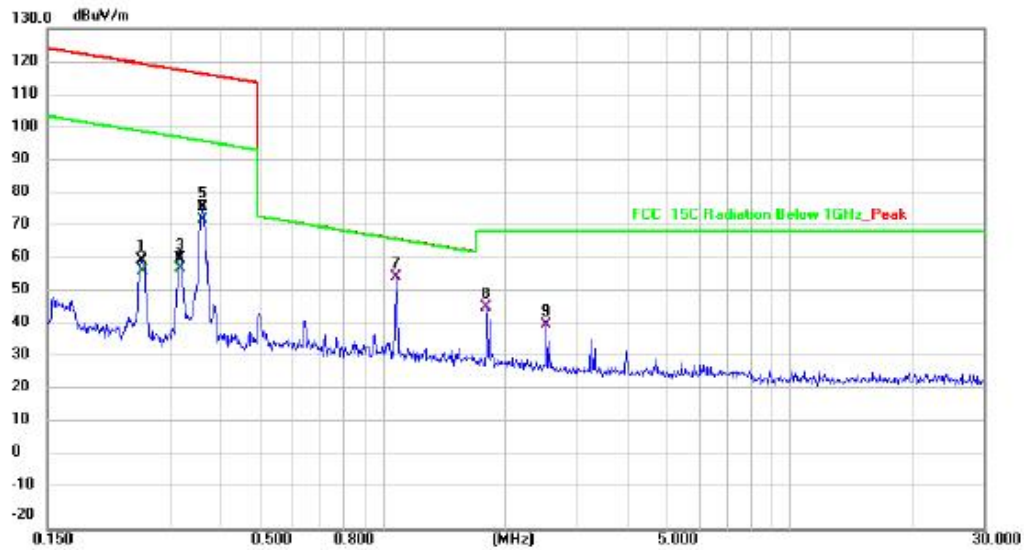

No.	Mk.	Freq. MHz	Reading Level dBuV	Correct Factor dB	Measure- ment dBuV/m	Limit dBuV/m	Over dB	Detector	Comment
1		0.2560	40.05	20.85	60.90	119.45	-58.55	peak	
2		0.2561	36.55	20.85	57.40	99.45	-42.05	AVG	
3		0.3183	40.29	20.99	61.28	117.55	-56.27	peak	
4		0.3183	37.31	20.99	58.30	97.55	-39.25	AVG	
5		0.3599	55.38	21.08	76.46	116.50	-40.04	peak	
6		0.3599	51.82	21.08	72.90	96.49	-23.59	AVG	
7	*	1.0823	32.88	22.76	55.64	66.94	-11.30	QP	
8		1.8000	22.39	24.24	46.63	69.50	-22.87	QP	
9		2.5266	15.39	25.75	41.14	69.50	-28.36	QP	

TEST REPORT

Report No.: MTi250515031-0104E1

Mode7 / EUT direction: X axis

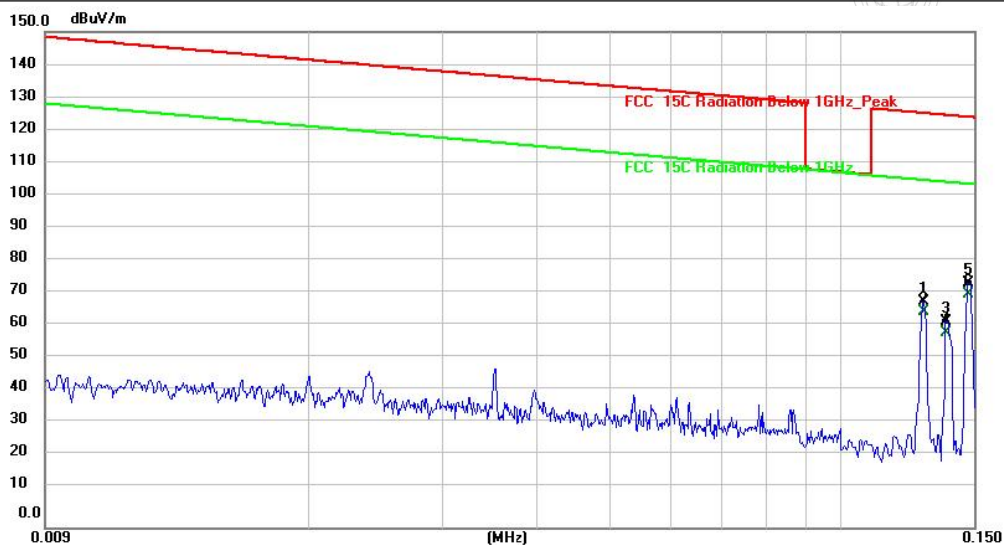

No.	Mk.	Freq. MHz	Reading Level dBuV	Correct Factor dB	Measure- ment dBuV/m	Limit dBuV/m	Over dB	Detector	Comment
1		0.1285	47.91	20.47	68.38	125.45	-57.07	peak	
2		0.1285	44.83	20.47	65.30	105.45	-40.15	AVG	
3		0.1374	42.05	20.52	62.57	124.86	-62.29	peak	
4		0.1374	38.38	20.52	58.90	104.86	-45.96	AVG	
5		0.1474	53.48	20.59	74.07	124.25	-50.18	peak	
6	*	0.1474	50.01	20.59	70.60	104.25	-33.65	AVG	

TEST REPORT

Report No.: MTi250515031-0104E1

Mode7 / EUT direction: X axis

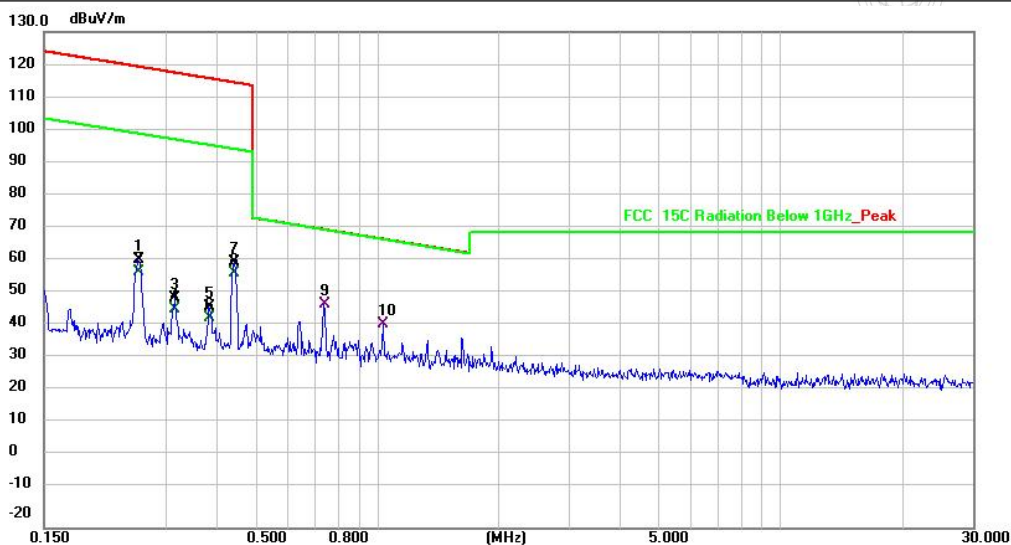

No.	Mk.	Freq. MHz	Reading Level dBuV	Correct Factor dB	Measure- ment dBuV/m	Limit dBuV/m	Over dB	Detector	Comment
1		0.2561	40.22	20.85	61.07	119.45	-58.38	peak	
2		0.2561	36.75	20.85	57.60	99.45	-41.85	AVG	
3		0.3149	28.41	20.97	49.38	117.65	-68.27	peak	
4		0.3149	25.13	20.97	46.10	97.65	-51.55	AVG	
5		0.3831	25.81	21.13	46.94	115.94	-69.00	peak	
6		0.3831	22.27	21.13	43.40	95.94	-52.54	AVG	
7		0.4420	39.35	21.26	60.61	114.70	-54.09	peak	
8		0.4420	35.84	21.26	57.10	94.70	-37.60	AVG	
9	*	0.7391	25.72	21.98	47.70	70.24	-22.54	QP	
10		1.0320	19.03	22.66	41.69	67.35	-25.66	QP	

TEST REPORT

Report No.: MTi250515031-0104E1

6.4 Emissions in frequency bands (30MHz - 1GHz)

Test Requirement:	47 CFR Part 15.209		
Test Limit:	Frequency (MHz)	Field strength (microvolts/meter)	Measurement distance (meters)
	0.009-0.490	2400/F(kHz)	300
	0.490-1.705	24000/F(kHz)	30
	1.705-30.0	30	30
	30-88	100 **	3
	88-216	150 **	3
	216-960	200 **	3
	Above 960	500	3
<p>** Except as provided in paragraph (g), fundamental emissions from intentional radiators operating under this section shall not be located in the frequency bands 54-72 MHz, 76-88 MHz, 174-216 MHz or 470-806 MHz. However, operation within these frequency bands is permitted under other sections of this part, e.g., §§ 15.231 and 15.241.</p> <p>In the emission table above, the tighter limit applies at the band edges. The emission limits shown in the above table are based on measurements employing a CISPR quasi-peak detector except for the frequency bands 9–90 kHz, 110–490 kHz and above 1000 MHz. Radiated emission limits in these three bands are based on measurements employing an average detector. As shown in § 15.35(b), for frequencies above 1000 MHz, the field strength limits in paragraphs (a) and (b) of this section are based on average limits. However, the peak field strength of any emission shall not exceed the maximum permitted average limits specified above by more than 20 dB under any condition of modulation. For point-to-point operation under paragraph (b) of this section, the peak field strength shall not exceed 2500 millivolts/meter at 3 meters along the antenna azimuth.</p>			
Test Method:	ANSI C63.10-2020 section 6.5		
Procedure:	ANSI C63.10-2020 section 6.5		

6.4.1 E.U.T. Operation:

Operating Environment:					
Temperature:	21 °C	Humidity:	51 %	Atmospheric Pressure:	101 kPa
Pre test mode:	Mode1, Mode2, Mode3, Mode4, Mode5, Mode6, Mode7, Mode8, Mode9, Mode10, Mode11, Mode12, Mode13, Mode14, Mode15, Mode16, Mode17, Mode18, Mode19, Mode20, Mode21, Mode22, Mode23, Mode24, Mode25, Mode26, Mode27, Mode28, Mode29, Mode30				
Final test mode:	All of the listed pre-test mode were tested, only the data of the worst mode (Mode4) is recorded in the report				

6.4.2 Test Setup Diagram:

--

TEST REPORT

Report No.: MTi250515031-0104E1

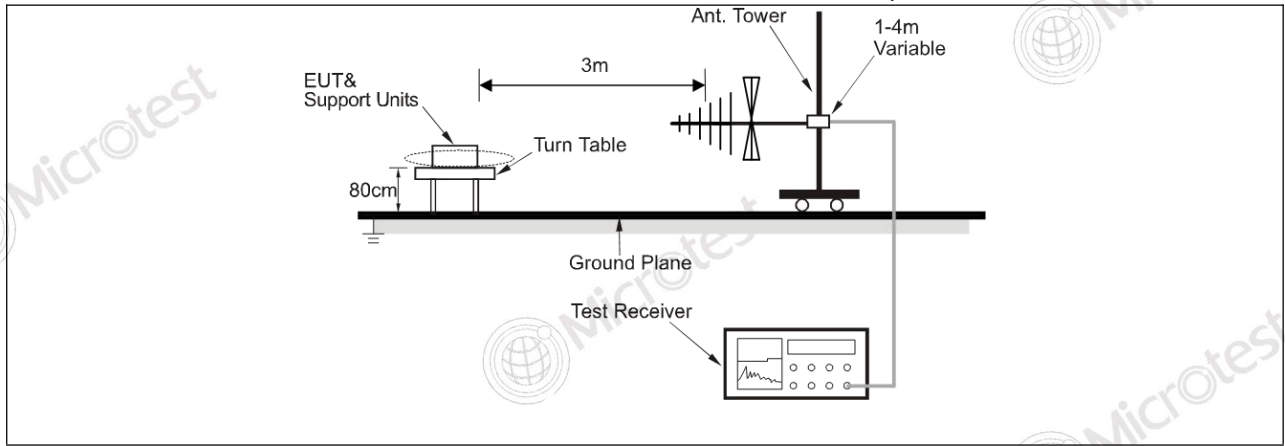

TEST REPORT

Report No.: MTi250515031-0104E1

6.4.3 Test Data:

Mode4 / Polarization: Horizontal

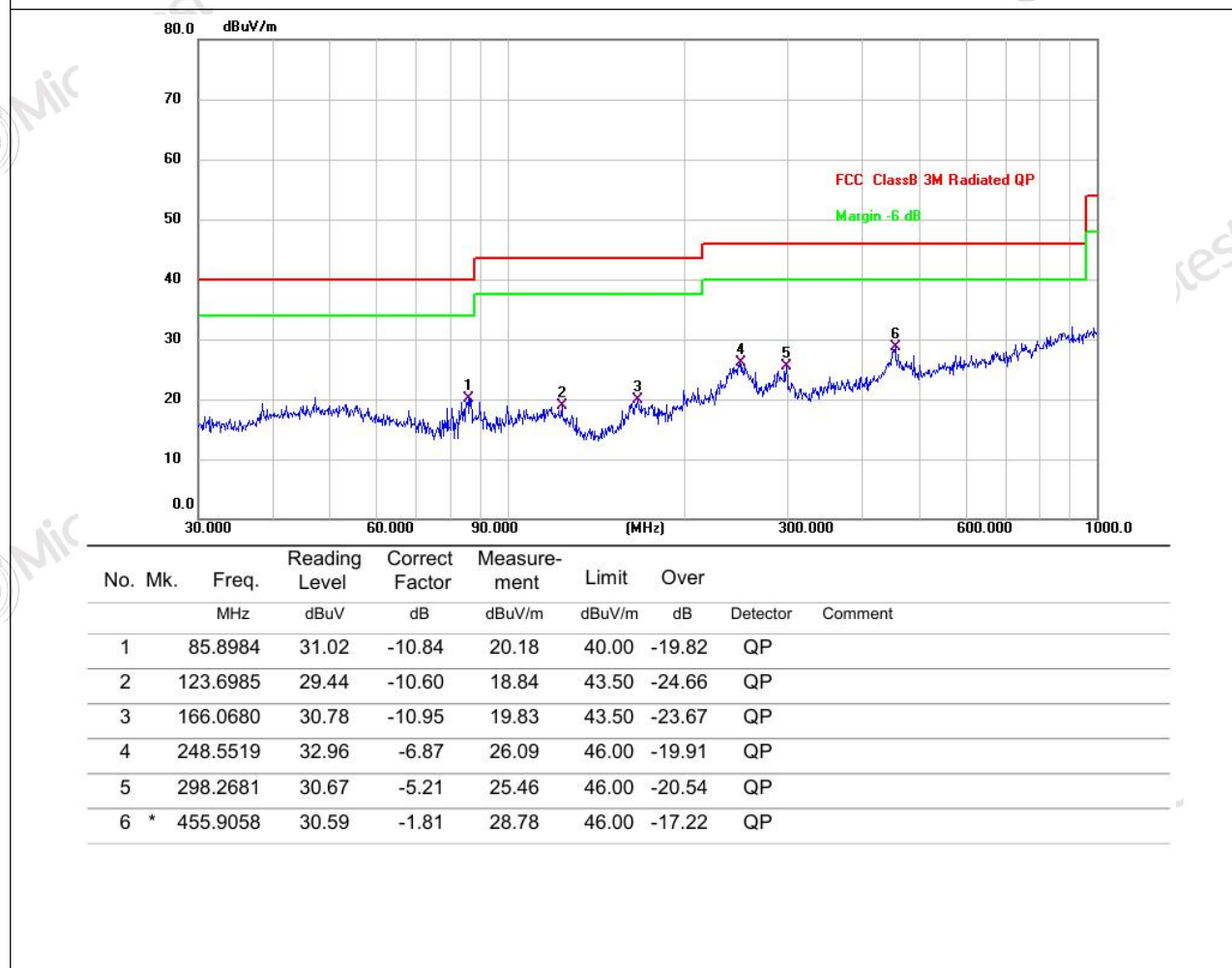

TEST REPORT

Report No.: MTi250515031-0104E1

Mode4 / Polarization: Vertical



No.	Mk.	Freq. MHz	Reading Level dBuV	Correct Factor dB	Measure- ment dBuV/m	Limit dBuV/m	Over dB	Detector	Comment
1	*	39.2991	43.30	-8.00	35.30	40.00	-4.70	QP	
2		67.9129	36.68	-9.81	26.87	40.00	-13.13	QP	
3		86.8068	36.23	-10.81	25.42	40.00	-14.58	QP	
4		120.2766	36.30	-9.98	26.32	43.50	-17.18	QP	
5		163.1818	43.35	-10.98	32.37	43.50	-11.13	QP	
6		224.5193	35.58	-8.20	27.38	46.00	-18.62	QP	

TEST REPORT

Report No.: MTi250515031-0104E1

Photographs of the test setup

Refer to Appendix - Test Setup Photos

TEST REPORT

Report No.: MTi250515031-0104E1

Photographs of the EUT

Refer to Appendix - EUT Photos

TEST REPORT

Report No.: MTi250515031-0104E1

Statement

1. This report is invalid without the seal and signature of the laboratory.
2. The test results of this report are only responsible for the samples submitted. Client shall be responsible for representativeness of the sample and authenticity of the material.
3. The report shall not be partially reproduced without the written consent of the Laboratory.
4. This report is invalid if transferred, altered or tampered with in any form without authorization.
5. The observations or tests with special mark fall outside the scope of accreditation, and are only used for purpose of commission, research, training, internal quality control etc.
6. Any objection to this report shall be submitted to the laboratory within 15 days from the date of receipt of the report.

***** END OF REPORT *****