



FCC PART15B TEST REPORT

For

FCC ID:	2AHK4S8X
Product Name:	G-Box Omnistick
Trademark:	N/A
Model Number:	S8X
Prepared For :	Matricom
Address :	498 Palm Springs Drive, Suite 255, Altamonte Springs, Florida, 32701
Prepared By :	Shenzhen BCTC Technology Co., Ltd.
Address :	A. Floor 3, 44 Building, Tanglang Industrial Park B, Taoyuan Street, Nanshan District, Shenzhen, China
Test Date:	Feb. 15 - Feb. 22, 2016
Date of Report :	Feb. 22, 2016
Report No.:	BCTC-151114656



TABLE OF CONTENTS

TEST REPORT DECLARATION	3
1. GENERAL INFORMATION	4
1.1. Report information.....	4
1.2. Measurement Uncertainty.....	4
1.3. Test Facility.....	4
1.4. Test Uncertainty.....	4
2. PRODUCT DESCRIPTION	5
2.1. EUT Description.....	5
2.2. Block Diagram of EUT Configuration.....	5
2.3. DESCRIPTION OF SUPPORT UNITS(CONDUCTED MODE).....	6
2.4. Test Conditions.....	6
3. TEST RESULTS SUMMARY	6
4. TEST EQUIPMENT USED	7
4.1. For Conducted Emission Test.....	7
4.2. For Radiated Emission Measurement.....	7
5. CONDUCTED EMISSION TEST	8
5.1. Block Diagram of Test Setup.....	8
5.2. Test Standard.....	8
5.3. Conducted Emission Limit (Class B).....	8
5.4. EUT Configuration on Test.....	8
5.5. Operating Condition of EUT.....	8
5.6. Test Procedure.....	9
5.7. Test Result.....	9
6. RADIATED EMISSION MEASUREMENT	12
6.1. Block Diagram of Test Setup.....	12
6.2. Test Standard.....	12
6.3. Radiated Emission Limit(Class B).....	12
6.4. EUT Configuration on Test.....	13
6.5. Test Procedure.....	13
6.6. Test Result.....	13
APPENDIX I (TEST PHOTOS OF THE EUT)	18
APPENDIX II (PHOTOS OF THE EUT)	21



TEST REPORT DECLARATION

Applicant : Matricom
Address : 498 Palm Springs Drive, Suite 255, Altamonte Springs, Florida, 32701
EUT Description : G-Box Omnistick
Model Number : S8X
Rating(s) : DC5V
Adapter : Input: AC100-240V~ 50/60Hz 0.5A
Output: 5.0V $\overline{\text{---}}$ 2.0A

Test Standards:

FCC Part 15 B: 2015
ANSI C63.4-2014

The EUT described above is tested by US to determine the maximum emission levels emanating from the EUT, the maximum emission levels are compared to the FCC Part 15 B Subpart Class B limits.

The measurement results are contained in this test report and Shenzhen BCTC Technology Co., Ltd. is assumed of full responsibility for the accuracy and completeness of these measurements.

Also, this report shows that the EUT is to be technically compliant with the FCC requirements.

This report applies to above tested sample only and shall not be reproduced in part without written approval of Shenzhen BCTC Technology Co., Ltd.

Testing Engineer : Eric Yang
(Eric Yang)

Technical Manager : Sophie Lu
(Sophia Lee)

Authorized Signatory : Carson Zhang
(Carson. Zhang)





1. GENERAL INFORMATION

1.1. Report information

- 1.1.1. This report is not a certificate of quality; it only applies to the sample of the specific product/equipment given at the time of its testing. The results are not used to indicate or imply that they are application to the similar items. In addition, such results must not be used to indicate or imply that BCTC approves recommends or endorses the manufacture, supplier or use of such product/equipment, or that BCTC in any way guarantees the later performance of the product/equipment.
- 1.1.2. The sample/s mentioned in this report is/are supplied by Applicant, BCTC therefore assumes no responsibility for the accuracy of information on the brand name, model number, origin of manufacture or any information supplied.
- 1.1.3. Additional copies of the report are available to the Applicant at an additional fee. No third part can obtain a copy of this report through BCTC, unless the applicant has authorized BCTC in writing to do so.

1.2. Measurement Uncertainty

Available upon request.

1.3. Test Facility

Site Description
Name of Firm : Shenzhen BCTC Technology Co., Ltd.

Site Location : A. Floor 3, 44 Building, Tanglang Industrial Park B,
Taoyuan Street, Nanshan District, Shenzhen, China

FCC Registration No. : 187086

1.4. Test Uncertainty

Conducted Emission Uncertainty = $\pm 2.66\text{dB}$
Radiated Emission Uncertainty = $\pm 4.15\text{dB}$



2. PRODUCT DESCRIPTION

2.1.EUT Description

Description : **G-Box Omnistick**
Applicant : **Matricom**
498 Palm Springs Drive, Suite 255, Altamonte Springs, Florida,
32701
Manufacturer : **Shenzhen Dongzhoujun Technology Co., Ltd**
2-4F.Buliding2#, Sanhe Village, Dalang, Longhua District,
Shenzhen, China
Model Number : **S8X**

2.2.Block Diagram of EUT Configuration

Conducted Emission Test

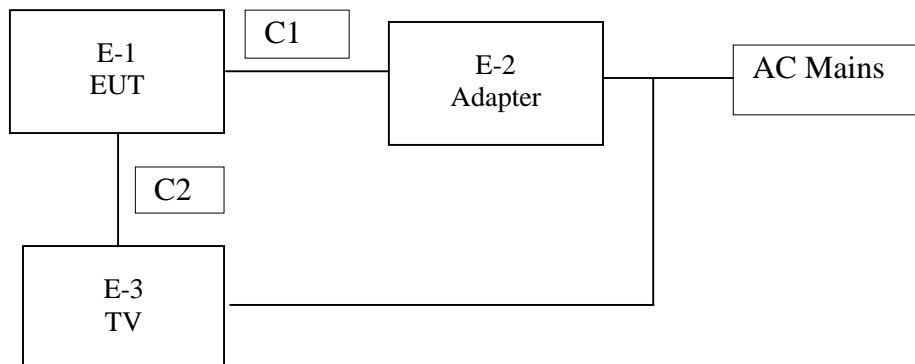



2.3.DESCRPTION OF SUPPORT UNITS(CONDUCTED MODE)

Item	Equipment	Mfr/Brand	Model/Type No.	Series No.	Note
E-1	G-Box Omnistick	N/A	S8X	N/A	EUT
E-2	Adapter	N/A	XHY050200UUCH	N/A	
E-3	TV	PHILIPS	24PFL3543/T3	WJ3C1528000141	AC100-240V 50/60Hz 36W

Item	Shielded Type	Ferrite Core	Length	Note
C1	NO	NO	0.8M	DC cable unshielded
C2	NO	NO	0.3M	HDMI cable shielded

2.4.Test Conditions

Temperature: 23~25℃

Relative Humidity: 55~63 %

3. TEST RESULTS SUMMARY

Table 1 Test Results Summary

Test Items	Test Results
Conducted disturbance	Pass
Radiated disturbance	Pass

Remark: "N/A" means "Not applicable."



4. TEST EQUIPMENT USED

4.1. For Conducted Emission Test

Conducted Emission Test (A --- site)					
Equipment	Manufacturer	Model#	Serial#	Last Cal.	Next Cal.
843 Shielded Room	ChengYu	843 Room	843	Aug. 25, 2015	Aug. 24, 2016
EMI Receiver	R&S	ESCI	101421	Aug. 27, 2015	Aug. 26, 2016
LISN	R&S	NSLK8126	8126466	Aug. 25, 2015	Aug. 24, 2016
LISN	R&S	NSLK8126	8126487	Aug. 25, 2015	Aug. 24, 2016
Attenuator	R&S	ESH3-Z2	BCTC021E	Aug. 25, 2015	Aug. 24, 2016
843 Cable 1#	FUJIKURA	843C1#	001	Aug. 25, 2015	Aug. 24, 2016

4.2. For Radiated Emission Measurement

Radiation Emission Test (966 chamber)					
Equipment	Manufacturer	Model#	Serial#	Last Cal.	Next Cal.
966 chamber	ChengYu	966 Room	966	Aug. 25, 2015	Aug. 24, 2016
Spectrum Analyzer	Agilent	E4407B	MY45109572	Aug. 27, 2015	Aug. 26, 2016
Amplifier	Schwarzbeck	BBV9743	9743-119	Aug. 25, 2015	Aug. 24, 2016
Amplifier	Schwarzbeck	BBV9718	9718-270	Aug. 25, 2015	Aug. 24, 2016
Log-periodic Antenna	Schwarzbeck	VULB9160	VULB9160-3369	Sep. 07, 2015	Sep. 06, 2016
EMI Receiver	R&S	ESCI	101421	Aug. 27, 2015	Aug. 26, 2016
Horn Antenna	Schwarzbeck	BBHA9120D	9120D-1275	Aug. 25, 2015	Aug. 24, 2016
966 Cable 1#	CHENGYU	966	004	Aug. 25, 2015	Aug. 24, 2016
966 Cable 2#	CHENGYU	966	003	Aug. 25, 2015	Aug. 24, 2016

5. CONDUCTED EMISSION TEST

5.1. Block Diagram of Test Setup

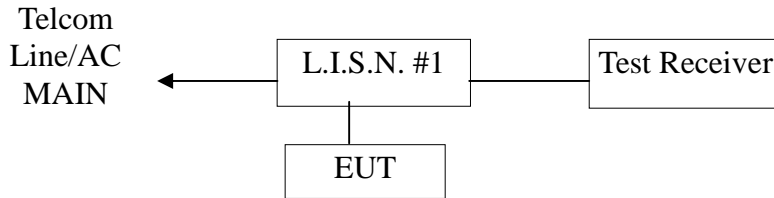

(EUT: G-Box Omnistick)

5.2. Test Standard

FCC Part 15 B: 2015

5.3. Conducted Emission Limit (Class B)

Frequency MHz	Limits dB(μV)	
	Quasi-peak Level	Average Level
0.15 ~ 0.50	66 ~ 56*	56 ~ 46*
0.50 ~ 5.00	56	46
5.00 ~ 30.00	60	50

Notes: 1. *Decreasing linearly with logarithm of frequency.

5.4. EUT Configuration on Test

The following equipments are installed on conducted emission test to meet Part 15 B requirement and operating in a manner, which tends to maximize its emission characteristics in a normal application.

5.4.1. G-Box Omnistick

Model Number: S8X

5.5. Operating Condition of EUT

5.5.1. Setup the EUT and simulators as shown in Section 5.1.

5.5.2. Turn on the power of all equipments.

5.5.3. Let the EUT work in test modes (EUT Working) and test it.



5.6. Test Procedure

The EUT is put on a table of non-conducting material that is 80cm high. The vertical conducting wall of shielding is located 40cm to the rear of the EUT. The power line of the EUT is connected to the AC mains through a Artificial Mains Network (A.M.N.). A EMI test receiver (R&S Test Receiver ESHS30) is used to test the emissions form both sides of AC line. The bandwidth of EMI test receiver is set at 9kHz.

The bandwidth of the test receiver (R&S Test Receiver ESHS30) is set at 10KHz.

5.7. Test Result

Please refer to the following pages.



EUT:	Smart lamp speaker	Model Name :	S8X
Temperature:	25 °C	Relative Humidity:	54%
Pressure:	1010 hPa	Polarization :	L
Test Voltage :	DC 5V from adapter input AC 120V/60Hz		
Test Mode : (Worst)	Link mode		

Frequency (MHz)	Meter Reading (dBμV)	Factor (dB)	Emission Level (dBμV)	Limits (dBμV)	Margin (dB)	Detector Type
0.1940	34.45	10.06	44.51	63.86	-19.35	QP
0.1940	26.32	10.06	36.38	53.86	-17.48	AVG
0.2860	28.49	10.09	38.58	60.64	-22.06	QP
0.2860	24.91	10.09	35.00	50.64	-15.64	AVG
0.3180	29.00	10.10	39.10	59.76	-20.66	QP
0.3180	23.95	10.10	34.05	49.76	-15.71	AVG
0.4780	26.37	10.11	36.48	56.37	-19.89	QP
0.4780	25.36	10.11	35.47	46.37	-10.90	AVG
2.2580	22.65	10.18	32.83	56.00	-23.17	QP
2.2580	17.63	10.18	27.81	46.00	-18.19	AVG
28.2020	33.67	10.21	43.88	60.00	-16.12	QP
28.2020	27.70	10.21	37.91	50.00	-12.09	AVG

Remark:

1. All readings are Quasi-Peak and Average values.
2. Factor = Insertion Loss + Cable Loss.

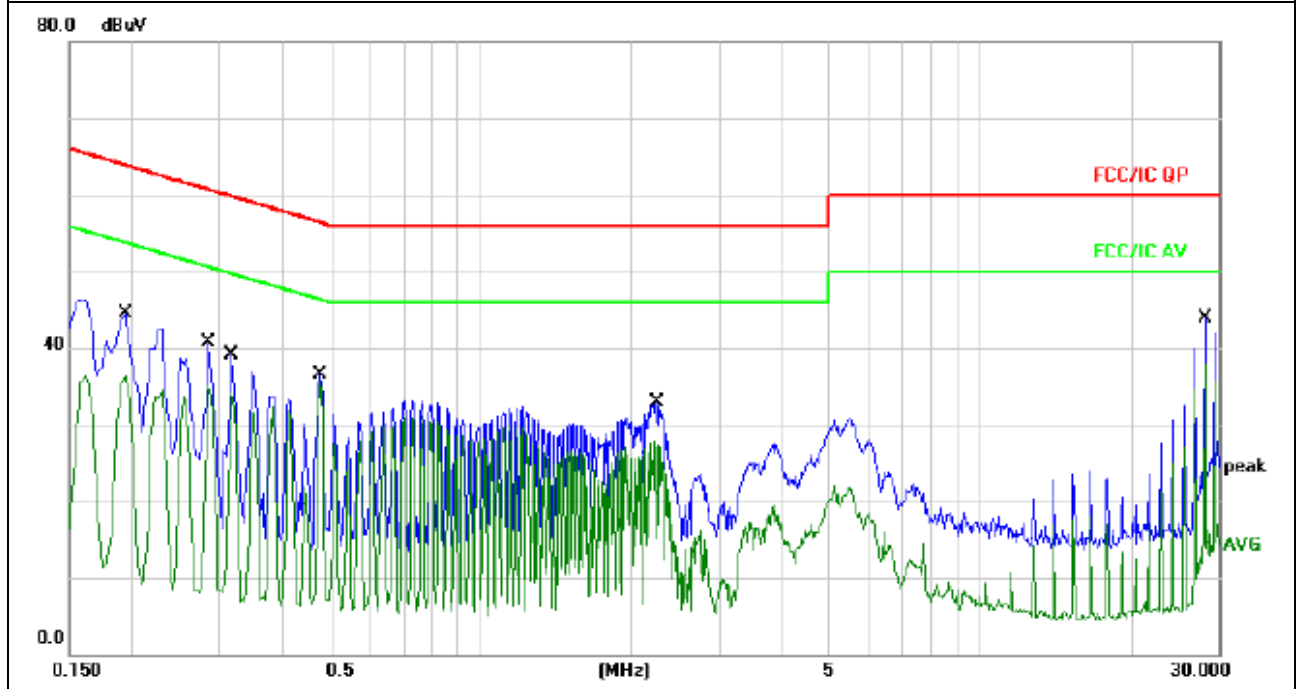



EUT:	Smart lamp speaker	Model Name :	S8X
Temperature:	25 °C	Relative Humidity:	54%
Pressure:	1010 hPa	Polarization :	N
Test Voltage :	DC 5V from adapter input AC 120V/60Hz		
Test Mode : (Worst)	Link mode		

Frequency (MHz)	Meter Reading (dBμV)	Factor (dB)	Emission Level (dBμV)	Limits (dBμV)	Margin (dB)	Detector Type
0.1819	40.14	10.06	50.20	64.39	-14.19	QP
0.1819	29.08	10.06	39.14	54.39	-15.25	AVG
0.2420	36.72	10.08	46.80	62.02	-15.22	QP
0.2420	27.65	10.08	37.73	52.02	-14.29	AVG
0.2740	33.02	10.09	43.11	60.99	-17.88	QP
0.2740	26.72	10.09	36.81	50.99	-14.18	AVG
0.3020	33.33	10.09	43.42	60.19	-16.77	QP
0.3020	26.19	10.09	36.28	50.19	-13.91	AVG
0.3620	29.74	10.10	39.84	58.68	-18.84	QP
0.3620	23.14	10.10	33.24	48.68	-15.44	AVG
2.2700	23.32	10.18	33.50	56.00	-22.50	QP
2.2700	19.01	10.18	29.19	46.00	-16.81	AVG

Remark:

1. All readings are Quasi-Peak and Average values.
2. Factor = Insertion Loss + Cable Loss.

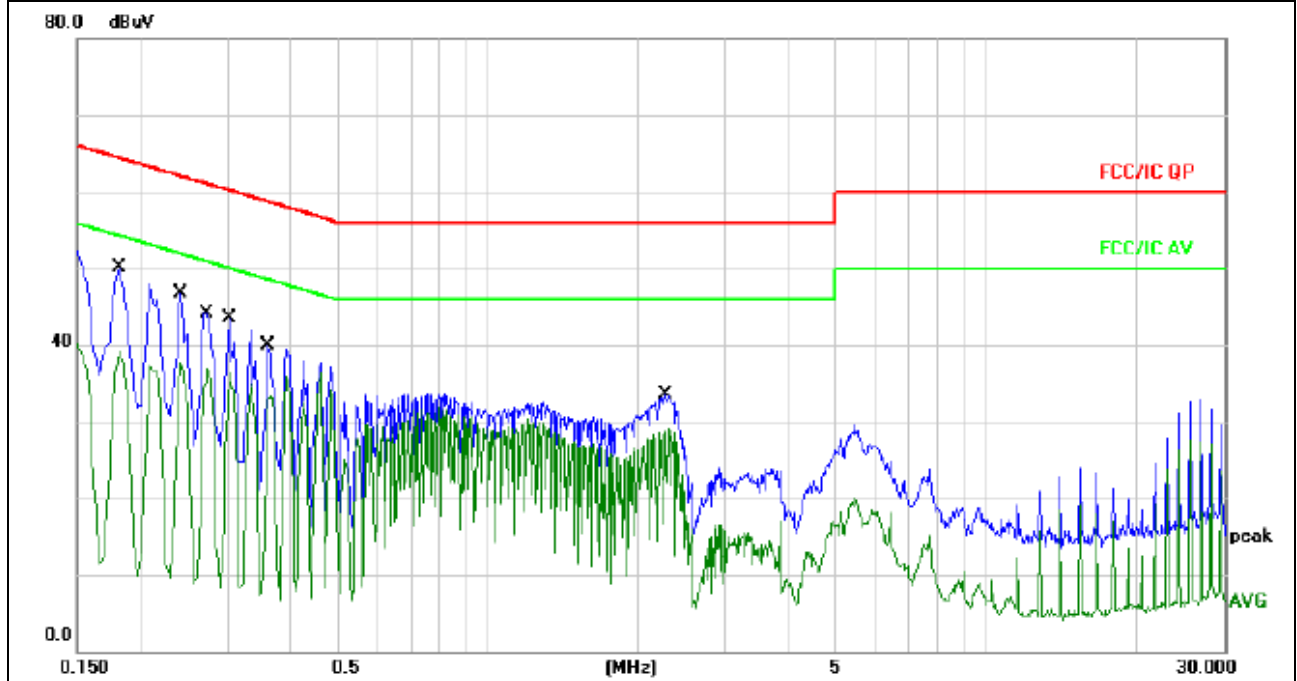

Note: We pretest AC 120V and AC 240V, the worst voltage was AC 120V and the data recording in the report.

6. RADIATED EMISSION MEASUREMENT

6.1. Block Diagram of Test Setup

6.1.1. Block Diagram of connection between the EUT and the simulators

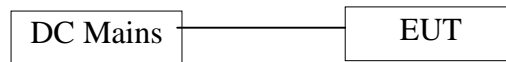

(EUT: G-Box Omnistick)

6.1.2. Anechoic Chamber Test Setup Diagram

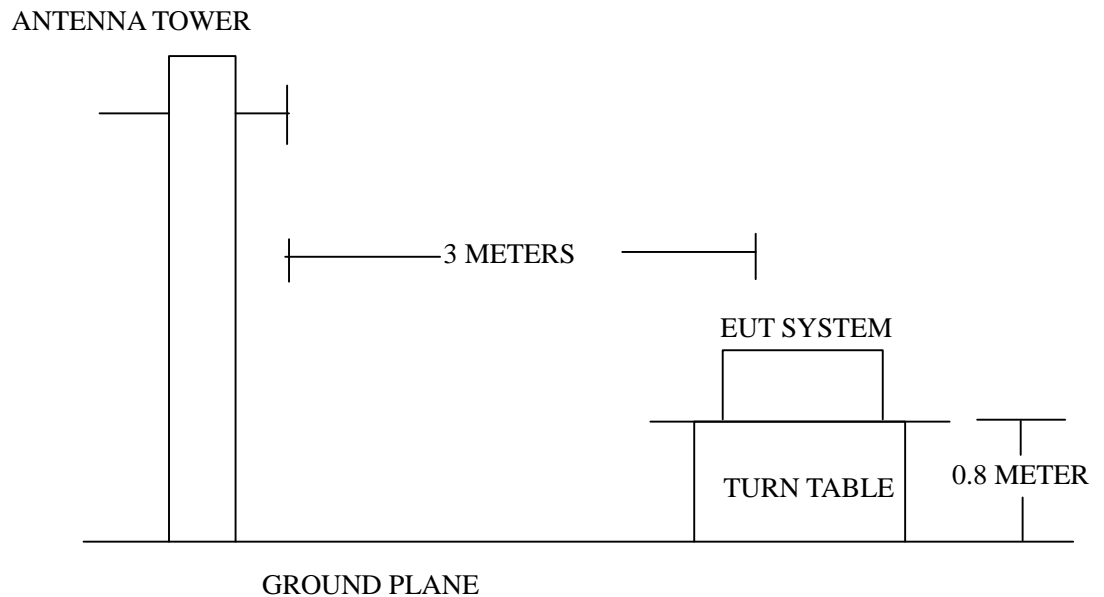

6.2. Test Standard

FCC Part 15 B: 2015

6.3. Radiated Emission Limit(Class B)

FREQUENCY (MHz)	DISTANCE (Meters)	FIELD STRENGTHS LIMITS (dBμV/m)
30 ~ 88	3	40.0
88 ~ 216	3	43.5
216 ~ 960	3	46.0
960 ~ 1000	3	54.0

Note:(1) The smaller limit shall apply at the edge between two frequency bands.

(2) Distance refers to the distance in meters between the measuring instrument antenna and the closed point of any part of the EUT or system.



6.4.EUT Configuration on Test

The following equipment are installed on Radiated Emission Measurement to meet the commission requirements and operating regulations in a manner which tends to maximize Its emission characteristics in normal application.

Operating Condition of EUT

6.4.1.Setup the EUT as shown on Section 6.1

6.4.2.Turn on the power of all equipments.

6.4.3.Let the EUT work in test mode(EUT working) and measure it.

6.5.Test Procedure

The EUT is placed on a turn table which is 0.8 meter above ground. The turn table can rotate 360 degrees to determine the position of the maximum emission level. The EUT is set 3 meters away from the receiving antenna which is mounted on a antenna tower. The antenna can move up and down between 1 to 4 meters to find out the maximum emission level. Broadband antenna (calibrated by dipole antenna) are used as a receiving antenna. Both horizontal and vertical polarization of the antenna are set on measurement.

The bandwidth setting on the test receiver is 120 KHz.

The EUT is tested in Anechoic Chamber. The frequency range from 30MHz to 1000MHz is checked. All the test results are listed in Section 6.6.

6.6.Test Result

PASS

Please refer to the following pages.



Radiated Spurious Emission (Between 30MHz – 1GHz)

EUT:	Smart lamp speaker	Model Name :	S8X
Temperature:	25 °C	Relative Humidity:	54%
Pressure:	1010 hPa	Polarization :	Horizontal
Test Voltage :	DC 5V from adapter		
Test Mode : (Worst)	Link mode		

Frequency (MHz)	Meter Reading (dBμV)	Factor (dB)	Emission Level (dBμV/m)	Limits (dBμV/m)	Margin (dB)	Detector Type
31.3992	41.93	-8.22	33.71	40.00	-6.29	QP
60.2800	42.97	-11.57	31.40	40.00	-8.60	QP
132.6850	43.66	-13.91	29.75	43.50	-13.75	QP
264.7456	52.06	-13.72	38.34	46.00	-7.66	QP
528.2458	47.25	-7.65	39.60	46.00	-6.40	QP
744.8660	43.19	-3.49	39.70	46.00	-6.30	QP

Remark:
Factor = Antenna Factor + Cable Loss – Pre-amplifier.

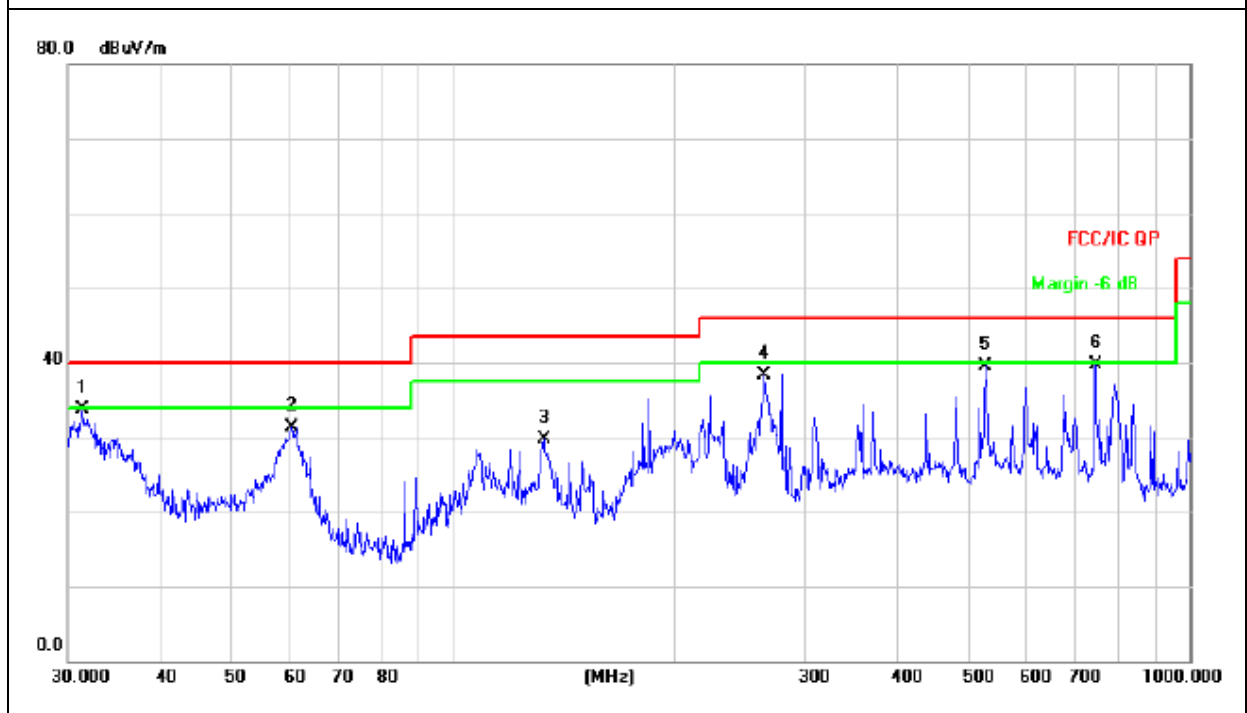



EUT:	Smart lamp speaker	Model Name :	S8X
Temperature:	25 °C	Relative Humidity:	54%
Pressure:	1010 hPa	Polarization :	Vertical
Test Voltage :	DC 5V from adapter		
Test Mode : (Worst)	Link mode		

Frequency (MHz)	Meter Reading (dBμV)	Factor (dB)	Emission Level (dBμV/m)	Limits (dBμV/m)	Margin (dB)	Detector Type
33.3278	45.38	-8.42	36.96	40.00	-3.04	QP
59.0251	47.72	-11.43	36.29	40.00	-3.71	QP
184.4898	47.72	-14.89	32.83	43.50	-10.67	QP
528.2458	47.08	-7.65	39.43	46.00	-6.57	QP
599.3212	45.73	-5.69	40.04	46.00	-5.96	QP
744.8660	41.11	-3.22	37.89	46.00	-8.11	QP

Remark:
Factor = Antenna Factor + Cable Loss – Pre-amplifier.

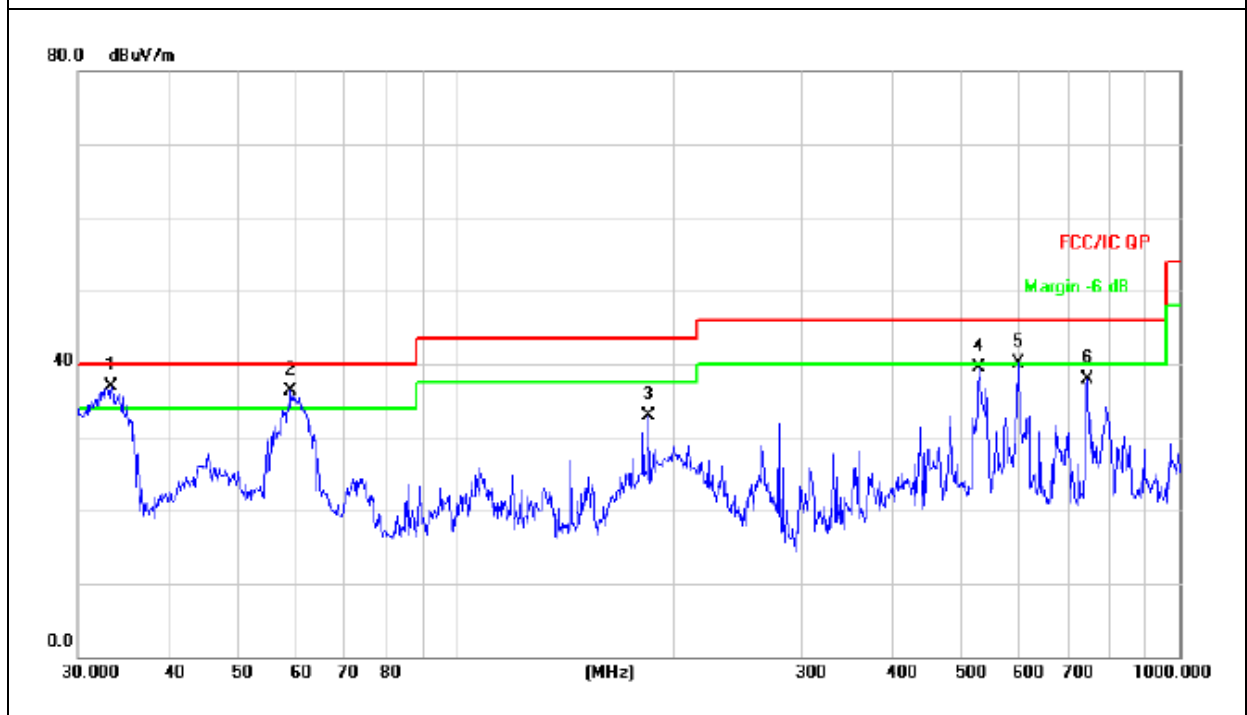



ABOVE 1GHz: (1G-12.5GHz)

EUT:	Smart lamp speaker	Model Name :	S8X
Temperature:	25 °C	Relative Humidity:	54%
Pressure:	1010 hPa	Polarization :	Horizontal
Test Voltage :	DC 5V from adapter		
Test Mode : (Worst)	Link mode		

Frequency (MHz)	Meter Reading (dBμV)	Factor (dB)	Emission Level (dBμV/m)	Limits (dBμV/m)	Margin (dB)	Detector Type
1488.750	38.55	12.61	51.16	74.00	-22.84	PK
1575.000	38.20	12.68	50.88	74.00	-23.12	PK
1805.000	37.27	12.86	50.13	74.00	-23.87	PK
1920.000	34.37	12.96	47.33	74.00	-26.67	PK
3875.000	28.03	18.00	46.03	74.00	-27.97	PK
10516.250	29.72	17.92	47.64	74.00	-26.36	PK

Remark:
Factor = Antenna Factor + Cable Loss – Pre-amplifier.

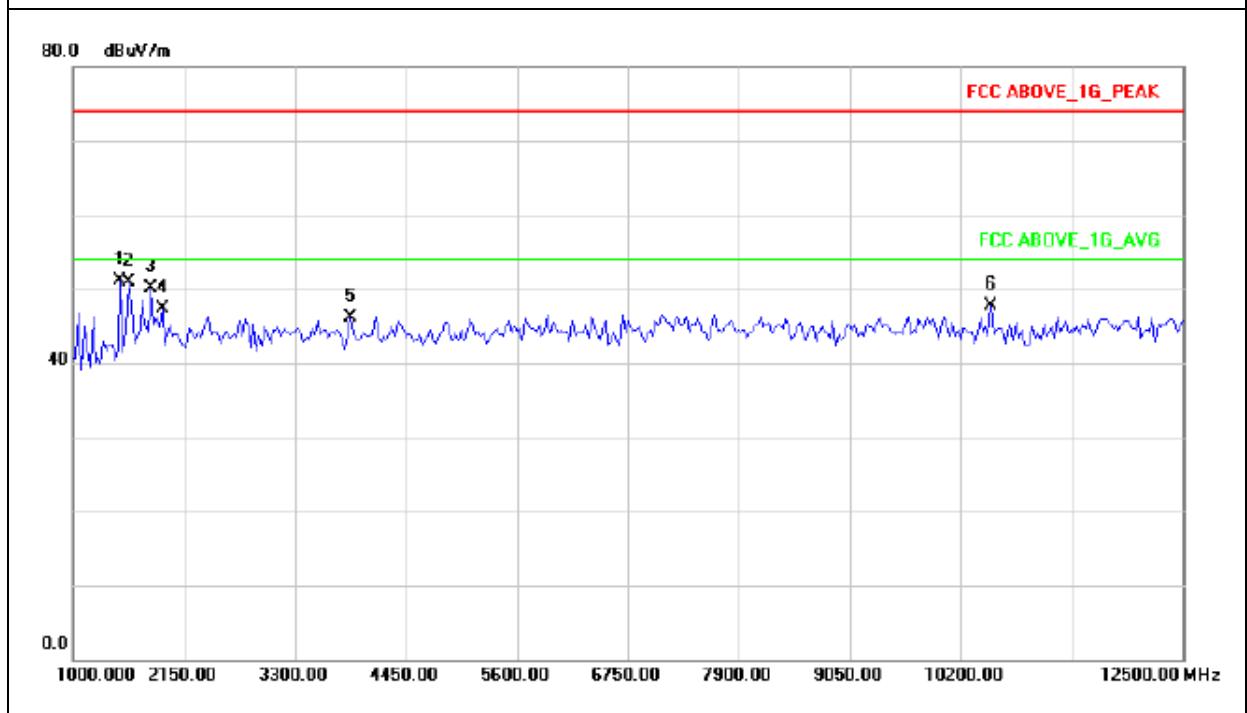



EUT:	Smart lamp speaker	Model Name :	S8X
Temperature:	25 °C	Relative Humidity:	54%
Pressure:	1010 hPa	Polarization :	Vertical
Test Voltage :	DC 5V from adapter		
Test Mode : (Worst)	Link mode		

Frequency (MHz)	Meter Reading (dBμV)	Factor (dB)	Emission Level (dBμV/m)	Limits (dBμV/m)	Margin (dB)	Detector Type
1316.250	40.25	12.47	52.72	74.00	-21.28	PK
1948.750	39.10	12.98	52.08	74.00	-21.92	PK
2236.250	37.41	13.50	50.91	74.00	-23.09	PK
2610.000	34.55	14.29	48.84	74.00	-25.16	PK
2983.750	36.34	15.06	51.40	74.00	-22.60	PK
9740.000	28.84	17.95	46.79	74.00	-27.21	PK

Remark:
Factor = Antenna Factor + Cable Loss – Pre-amplifier.

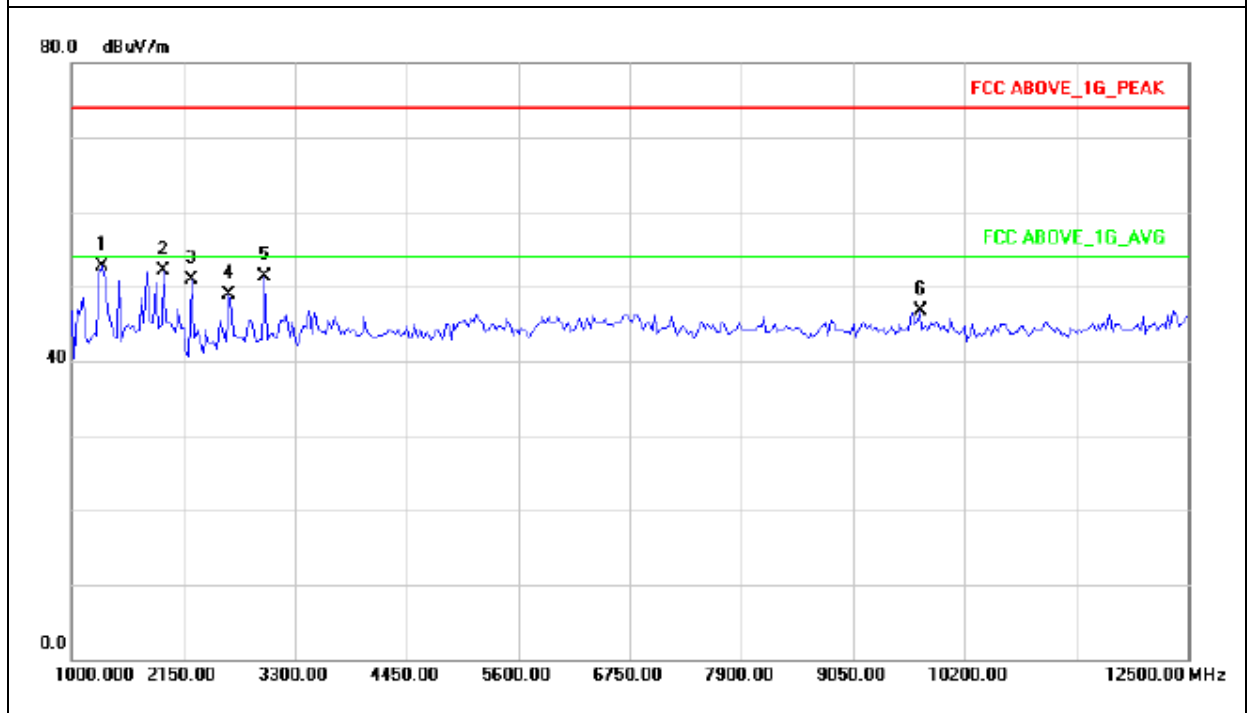



APPENDIX I (TEST PHOTOS OF THE EUT)

CE



RE

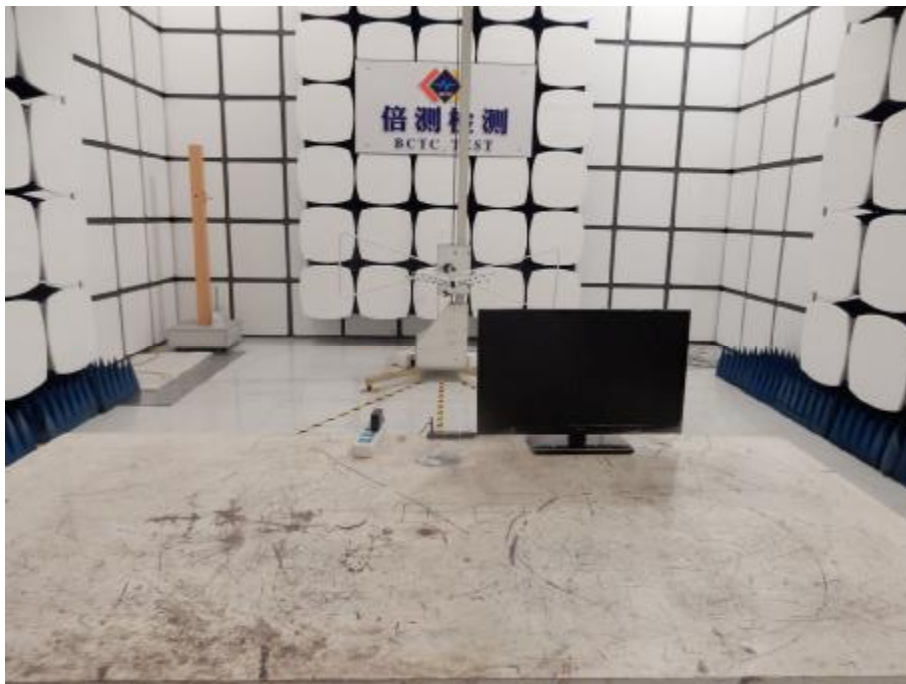

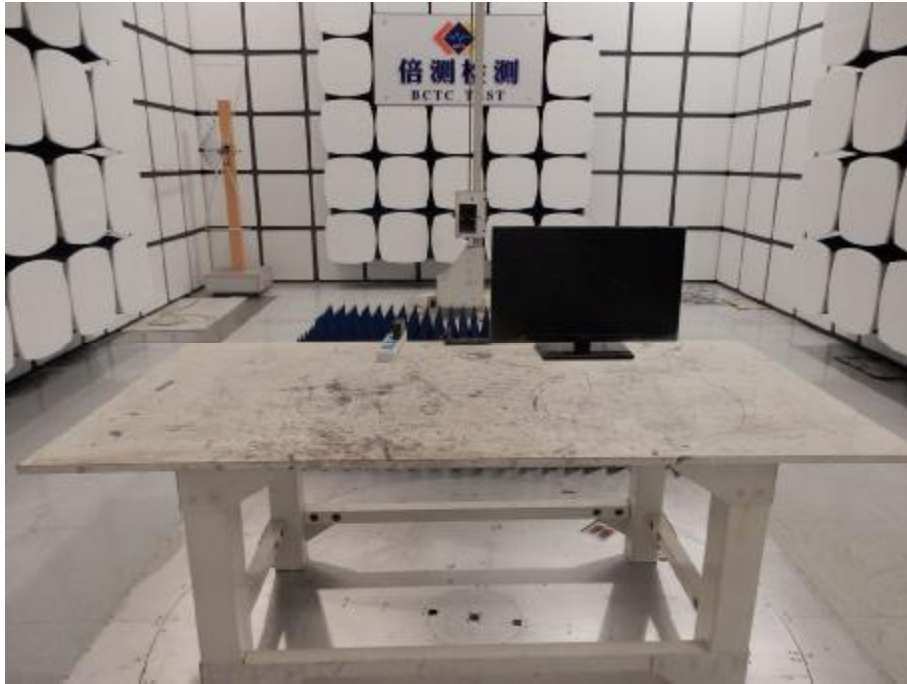



APPENDIX II (PHOTOS OF THE EUT)



***** END OF REPORT *****