

PowerLogic T300 Substation Controller

# HU250

Control and Communication Unit

## Installation Guide



NHA77925-12

**NOTE**

Electrical equipment must be installed, operated, serviced, and maintained only by qualified personnel. No responsibility is assumed by Schneider Electric for any consequences arising out of the use of this material.

A qualified person is one who has skills and knowledge related to the construction, installation, and operation of electrical equipment and has received safety training to recognize and avoid the hazards involved.



**Notes:**  
This Installation Guide is related to EMS59000 module. The configuration shown in the picture above is equipped with the optional EMS59151 modem on slot 1 and the optional EMS59155 modem on slot 2.



## Description

The HU250 module of the PowerLogic™ T300 range is the communication gateway dedicated to remote control applications for T300 units.

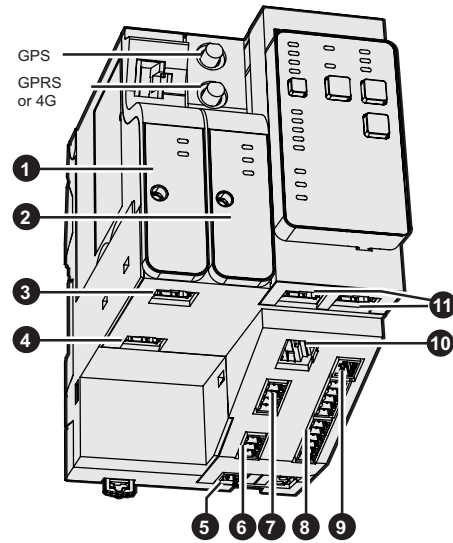

**NOTICE**

**HAZARD OF INCORRECT CURRENT MEASUREMENTS**

- Do not expose the device to conditions exceeding the electrical values specified in this document.
- Install the device vertically in an electrical cabinet, in accordance with the local regulations in force.
- Connect the product to the ground (DIN rail) to help ensure compliance with electromagnetic compatibility (EMC) limits.
- Standby protection should be provided in accordance with national and international cabling regulations.
- An appropriate electrical disconnecting device must be installed in the building in question.
- Use only the type of connector supplied as an accessory for the HU250 module (product reference: EMS59010).
- Check that the connections correspond to the recommended cables before powering up the equipment.
- Use appropriate tools to perform cabling on the connectors (suitable screwdriver, crimped end-pieces, etc).
- Strip the wires appropriately (not excessively) before connecting them to the connectors (see the recommendations in *Cabling* section in this document).

**Failure to follow these instructions can result in equipment damage.**

The HU250 includes the following components:

Port	Characteristics																																													
<b>1 2</b> <b>Communication ports</b>  	HU250 slots 1 and 2 can be fitted with the following modem options: <ul style="list-style-type: none"> <li>EMS59150: empty modem box</li> <li>EMS59151: RS-232/RS-422/RS-485 modem (speed up to 115,200 bps - isolation 2 kVac - RJ45 connector) with the following pin-out:</li> </ul> <table border="1"> <thead> <tr> <th>PIN No.</th> <th>RS-232</th> <th>RS-422 (4-wire)</th> <th>RS-485 (2-wire)</th> </tr> </thead> <tbody> <tr><td>1</td><td>TXD</td><td>RXD0 (A')</td><td></td></tr> <tr><td>2</td><td>RXD</td><td>RXD1 (B')</td><td></td></tr> <tr><td>3</td><td>CTS</td><td></td><td></td></tr> <tr><td>4</td><td>DTR</td><td>TXD1 (B)</td><td>D1 (B)</td></tr> <tr><td>5</td><td>DSR</td><td>TXD0 (A)</td><td>D0 (A)</td></tr> <tr><td>6</td><td>RTS</td><td></td><td></td></tr> <tr><td>7</td><td>DCD</td><td></td><td></td></tr> <tr><td>8</td><td>GND</td><td>GND (C/C)</td><td>GND</td></tr> </tbody> </table> <ul style="list-style-type: none"> <li>EMS59155: 4G modem with GPS time synchronization</li> <li>EMS59156: Zigbee receiver (connection to CL110 and TH110)</li> </ul> <table border="1"> <thead> <tr> <th>Modem</th> <th>Frequencies</th> <th>Maximum transmitted power (dBm)</th> </tr> </thead> <tbody> <tr> <td>4G</td> <td> <ul style="list-style-type: none"> <li>Hexa FDD band: bands 28 (700 MHz), 20 (800 MHz), 8 (900 MHz), 3 (1,800 MHz), 1 (2,100 MHz), 7 (2,600 MHz)</li> <li>Dual band GSM/GPRS/EDGE: bands 8 (900 MHz), 3 (1,800 MHz)</li> </ul> </td> <td>23</td> </tr> <tr> <td>Zigbee receiver</td> <td>Operating frequency range (IEEE 802.15.4): 2480 - 2405 MHz</td> <td>7</td> </tr> </tbody> </table>	PIN No.	RS-232	RS-422 (4-wire)	RS-485 (2-wire)	1	TXD	RXD0 (A')		2	RXD	RXD1 (B')		3	CTS			4	DTR	TXD1 (B)	D1 (B)	5	DSR	TXD0 (A)	D0 (A)	6	RTS			7	DCD			8	GND	GND (C/C)	GND	Modem	Frequencies	Maximum transmitted power (dBm)	4G	<ul style="list-style-type: none"> <li>Hexa FDD band: bands 28 (700 MHz), 20 (800 MHz), 8 (900 MHz), 3 (1,800 MHz), 1 (2,100 MHz), 7 (2,600 MHz)</li> <li>Dual band GSM/GPRS/EDGE: bands 8 (900 MHz), 3 (1,800 MHz)</li> </ul>	23	Zigbee receiver	Operating frequency range (IEEE 802.15.4): 2480 - 2405 MHz	7
PIN No.	RS-232	RS-422 (4-wire)	RS-485 (2-wire)																																											
1	TXD	RXD0 (A')																																												
2	RXD	RXD1 (B')																																												
3	CTS																																													
4	DTR	TXD1 (B)	D1 (B)																																											
5	DSR	TXD0 (A)	D0 (A)																																											
6	RTS																																													
7	DCD																																													
8	GND	GND (C/C)	GND																																											
Modem	Frequencies	Maximum transmitted power (dBm)																																												
4G	<ul style="list-style-type: none"> <li>Hexa FDD band: bands 28 (700 MHz), 20 (800 MHz), 8 (900 MHz), 3 (1,800 MHz), 1 (2,100 MHz), 7 (2,600 MHz)</li> <li>Dual band GSM/GPRS/EDGE: bands 8 (900 MHz), 3 (1,800 MHz)</li> </ul>	23																																												
Zigbee receiver	Operating frequency range (IEEE 802.15.4): 2480 - 2405 MHz	7																																												
<b>3</b> <b>Local communication Ethernet port</b> 	10/100 Base-T RJ45 connector Ethernet port used for the link to an external device in the MV substation or for connection to a PC. Isolation: 2 kVac																																													
<b>4</b> <b>Remote communication Ethernet port</b> 	10/100 Base-T RJ45 connector Ethernet port used for the remote link to the control center, via a modem or router. Isolation: 4 kVac																																													
<b>5</b> <b>Power supply</b> 	Plug-in screw connectors: <table border="1"> <thead> <tr> <th colspan="2">Power supply</th> </tr> </thead> <tbody> <tr><td>+</td><td>+Vdc (+12 V to +48 V)</td></tr> <tr><td>-</td><td>0 V</td></tr> </tbody> </table>	Power supply		+	+Vdc (+12 V to +48 V)	-	0 V																																							
Power supply																																														
+	+Vdc (+12 V to +48 V)																																													
-	0 V																																													
<b>6</b> <b>Indicator outputs</b> 	Plug-in screw connector: <table border="1"> <thead> <tr> <th colspan="2">Indicator lamps</th> </tr> </thead> <tbody> <tr><td>1</td><td>Indicator 1</td></tr> <tr><td>2</td><td>Common 5 V</td></tr> <tr><td>3</td><td>Indicator 2</td></tr> </tbody> </table> 2 polarized indicator outputs for external indication outside the MV substation. These indicators can be assigned by configuration to fault current detection indication (directional indication). Refer to the <i>PowerLogic T300 Quick Start Guide</i> . Voltage delivered: 5 V Max. current: 100 mA <b>Note:</b> These outputs are polarized. Comply with the direction of connection.	Indicator lamps		1	Indicator 1	2	Common 5 V	3	Indicator 2																																					
Indicator lamps																																														
1	Indicator 1																																													
2	Common 5 V																																													
3	Indicator 2																																													
<b>7</b> <b>Digital outputs</b> 	Plug-in screw connector: <table border="1"> <thead> <tr> <th colspan="2">Digital outputs</th> </tr> </thead> <tbody> <tr><td>1</td><td>DO1</td></tr> <tr><td>2</td><td>DO1</td></tr> <tr><td>3</td><td>DO2</td></tr> <tr><td>4</td><td>DO2</td></tr> </tbody> </table> 2 dry-contact digital outputs for free use. Breaking capacity: 2,000 VA Max. voltage: 60 Vdc Max. current: 2 A Isolation: 2 kVac	Digital outputs		1	DO1	2	DO1	3	DO2	4	DO2																																			
Digital outputs																																														
1	DO1																																													
2	DO1																																													
3	DO2																																													
4	DO2																																													
<b>8</b> <b>Digital inputs</b> 	Plug-in screw connectors: <table border="1"> <thead> <tr> <th colspan="2">Digital inputs 1</th> </tr> </thead> <tbody> <tr><td>1</td><td>Common (0 V)</td></tr> <tr><td>2</td><td>Digital input 1</td></tr> <tr><td>3</td><td>Digital input 2</td></tr> <tr><td>4</td><td>Digital input 3</td></tr> <tr><td>5</td><td>Digital input 4</td></tr> </tbody> </table> <table border="1"> <thead> <tr> <th colspan="2">Digital inputs 2</th> </tr> </thead> <tbody> <tr><td>1</td><td>Common (0 V)</td></tr> <tr><td>2</td><td>Voltage presence</td></tr> <tr><td>3</td><td>Door open</td></tr> <tr><td>4</td><td>Common (0 V)</td></tr> <tr><td>5</td><td>Local</td></tr> <tr><td>6</td><td>Remote</td></tr> </tbody> </table>	Digital inputs 1		1	Common (0 V)	2	Digital input 1	3	Digital input 2	4	Digital input 3	5	Digital input 4	Digital inputs 2		1	Common (0 V)	2	Voltage presence	3	Door open	4	Common (0 V)	5	Local	6	Remote																			
Digital inputs 1																																														
1	Common (0 V)																																													
2	Digital input 1																																													
3	Digital input 2																																													
4	Digital input 3																																													
5	Digital input 4																																													
Digital inputs 2																																														
1	Common (0 V)																																													
2	Voltage presence																																													
3	Door open																																													
4	Common (0 V)																																													
5	Local																																													
6	Remote																																													
<b>9</b> <b>Analog inputs</b> 	Plug-in leaf-spring connector: <table border="1"> <thead> <tr> <th colspan="2">PT100</th> </tr> </thead> <tbody> <tr><td>1</td><td>In1</td></tr> <tr><td>2</td><td>In2</td></tr> <tr><td>3</td><td>Ref</td></tr> </tbody> </table> 2 analog inputs for connection of one 3 wire PT100 temperature sensor. Measurement: -55 °C to 250 °C (-67 °F to 482 °F) Resolution: 1 °C (1 °F)	PT100		1	In1	2	In2	3	Ref																																					
PT100																																														
1	In1																																													
2	In2																																													
3	Ref																																													
<b>10</b> <b>RS-485 port</b> 	RJ45 connector capable of including the following connections: <table border="1"> <thead> <tr> <th colspan="2">RS-485 (2-wire)</th> </tr> </thead> <tbody> <tr><td>1</td><td></td></tr> <tr><td>2</td><td></td></tr> <tr><td>3</td><td></td></tr> <tr><td>4</td><td>D1 (B)</td></tr> <tr><td>5</td><td>D0 (A)</td></tr> <tr><td>6</td><td></td></tr> <tr><td>7</td><td></td></tr> <tr><td>8</td><td></td></tr> </tbody> </table>	RS-485 (2-wire)		1		2		3		4	D1 (B)	5	D0 (A)	6		7		8																												
RS-485 (2-wire)																																														
1																																														
2																																														
3																																														
4	D1 (B)																																													
5	D0 (A)																																													
6																																														
7																																														
8																																														
<b>11</b> <b>Double Ethernet ports LAN 1 and 2</b> 	10/100 Base-T RJ45 connectors Double ports dedicated to internal communication between T300 modules or for connection to a PC. Isolation: 2 kVac 10 Ethernet jumpers (Ref: EMS59528) provided as accessories allow the internal Ethernet connection between the HU250, SC150, SC160 and LV150 modules. See <i>LAN port NOTICE</i> .																																													
<b>12</b> <b>Wi-Fi port</b> 	Dual-band concurrent Wi-Fi (2.4 GHz/5 GHz) <table border="1"> <thead> <tr> <th>Parameter</th> <th>Value</th> <th>Unit</th> </tr> </thead> <tbody> <tr> <td>Operating frequency range</td> <td>2400 - 2483.5</td> <td>MHz</td> </tr> <tr> <td>Maximum transmitted power</td> <td>18.2</td> <td>dBm</td> </tr> </tbody> </table> WI-Fi hotspot with security for local connection with a PC, a tablet or a smartphone to: <ul style="list-style-type: none"> <li>The T300 embedded Web server</li> <li>The Easergy Builder advanced configuration tool</li> </ul>	Parameter	Value	Unit	Operating frequency range	2400 - 2483.5	MHz	Maximum transmitted power	18.2	dBm																																				
Parameter	Value	Unit																																												
Operating frequency range	2400 - 2483.5	MHz																																												
Maximum transmitted power	18.2	dBm																																												

Port	Characteristics	Description									
<b>3</b> <b>Local communication Ethernet port</b> 	10/100 Base-T RJ45 connector Ethernet port used for the link to an external device in the MV substation or for connection to a PC. Isolation: 2 kVac										
<b>4</b> <b>Remote communication Ethernet port</b> 	10/100 Base-T RJ45 connector Ethernet port used for the remote link to the control center, via a modem or router. Isolation: 4 kVac										
<b>5</b> <b>Power supply</b> 	Plug-in screw connectors: <table border="1"> <thead> <tr> <th colspan="2">Power supply</th> </tr> </thead> <tbody> <tr><td>+</td><td>+Vdc (+12 V to +48 V)</td></tr> <tr><td>-</td><td>0 V</td></tr> </tbody> </table>	Power supply		+	+Vdc (+12 V to +48 V)	-	0 V				
Power supply											
+	+Vdc (+12 V to +48 V)										
-	0 V										
<b>6</b> <b>Indicator outputs</b> 	Plug-in screw connector: <table border="1"> <thead> <tr> <th colspan="2">Indicator lamps</th> </tr> </thead> <tbody> <tr><td>1</td><td>Indicator 1</td></tr> <tr><td>2</td><td>Common 5 V</td></tr> <tr><td>3</td><td>Indicator 2</td></tr> </tbody> </table> 2 polarized indicator outputs for external indication outside the MV substation. These indicators can be assigned by configuration to fault current detection indication (directional indication). Refer to the <i>PowerLogic T300 Quick Start Guide</i> . Voltage delivered: 5 V Max. current: 100 mA <b>Note:</b> These outputs are polarized. Comply with the direction of connection.	Indicator lamps		1	Indicator 1	2	Common 5 V	3	Indicator 2		
Indicator lamps											
1	Indicator 1										
2	Common 5 V										
3	Indicator 2										
<b>7</b> <b>Digital outputs</b> 	Plug-in screw connector: <table border="1"> <thead> <tr> <th colspan="2">Digital outputs</th> </tr> </thead> <tbody> <tr><td>1</td><td>DO1</td></tr> <tr><td>2</td><td>DO1</td></tr> <tr><td>3</td><td>DO2</td></tr> <tr><td>4</td><td>DO2</td></tr> </tbody> </table> 2 dry-contact digital outputs for free use. Breaking capacity: 2,000 VA Max. voltage: 60 Vdc Max. current: 2 A Isolation: 2 kVac	Digital outputs		1	DO1	2	DO1	3	DO2	4	DO2
Digital outputs											
1	DO1										
2	DO1										
3	DO2										
4	DO2										

**NOTICE**

**HAZARD OF MISUSING LAN PORT 1 AND 2**

The T300 LAN network was designed for internal communications between the T300 modules. It is also possible to connect to this LAN via a PC to establish an Ethernet connection to the equipment. Other use does not guarantee correct functionality of the system.

**Failure to follow these instructions can result in equipment malfunction.**

**NOTICE**

**HAZARD OF TERMINAL DAMAGE OR INCORRECT POWER SUPPLY**

- Use appropriate tightening torques for tightening connector screws (tightening torque values provided in this document).
- The digital inputs accept only dry contacts. Consequently, these inputs must not receive voltage.
- The HU250 module must be powered by a power supply of the SELV/PELV type (e.g. the PSS0 module).
- The supply voltage of the HU250 module must not exceed 57.6 Vdc.

**Failure to follow these instructions can result in equipment damage.**

Port	Characteristics	Description																									
<b>8</b> <b>Digital inputs</b> 	Plug-in screw connectors: <table border="1"> <thead> <tr> <th colspan="2">Digital inputs 1</th> </tr> </thead> <tbody> <tr><td>1</td><td>Common (0 V)</td></tr> <tr><td>2</td><td>Digital input 1</td></tr> <tr><td>3</td><td>Digital input 2</td></tr> <tr><td>4</td><td>Digital input 3</td></tr> <tr><td>5</td><td>Digital input 4</td></tr> </tbody> </table> <table border="1"> <thead> <tr> <th colspan="2">Digital inputs 2</th> </tr> </thead> <tbody> <tr><td>1</td><td>Common (0 V)</td></tr> <tr><td>2</td><td>Voltage presence</td></tr> <tr><td>3</td><td>Door open</td></tr> <tr><td>4</td><td>Common (0 V)</td></tr> <tr><td>5</td><td>Local</td></tr> <tr><td>6</td><td>Remote</td></tr> </tbody> </table>	Digital inputs 1		1	Common (0 V)	2	Digital input 1	3	Digital input 2	4	Digital input 3	5	Digital input 4	Digital inputs 2		1	Common (0 V)	2	Voltage presence	3	Door open	4	Common (0 V)	5	Local	6	Remote
Digital inputs 1																											
1	Common (0 V)																										
2	Digital input 1																										
3	Digital input 2																										
4	Digital input 3																										
5	Digital input 4																										
Digital inputs 2																											
1	Common (0 V)																										
2	Voltage presence																										
3	Door open																										
4	Common (0 V)																										
5	Local																										
6	Remote																										
<b>9</b> <b>Analog inputs</b> 	Plug-in leaf-spring connector: <table border="1"> <thead> <tr> <th colspan="2">PT100</th> </tr> </thead> <tbody> <tr><td>1</td><td>In1</td></tr> <tr><td>2</td><td>In2</td></tr> <tr><td>3</td><td>Ref</td></tr> </tbody> </table> 2 analog inputs for connection of one 3 wire PT100 temperature sensor. Measurement: -55 °C to 250 °C (-67 °F to 482 °F) Resolution: 1 °C (1 °F)	PT100		1	In1	2	In2	3	Ref																		
PT100																											
1	In1																										
2	In2																										
3	Ref																										
<b>10</b> <b>RS-485 port</b> 	RJ45 connector capable of including the following connections: <table border="1"> <thead> <tr> <th colspan="2">RS-485 (2-wire)</th> </tr> </thead> <tbody> <tr><td>1</td><td></td></tr> <tr><td>2</td><td></td></tr> <tr><td>3</td><td></td></tr> <tr><td>4</td><td>D1 (B)</td></tr> <tr><td>5</td><td>D0 (A)</td></tr> <tr><td>6</td><td></td></tr> <tr><td>7</td><td></td></tr> <tr><td>8</td><td></td></tr> </tbody> </table>	RS-485 (2-wire)		1		2		3		4	D1 (B)	5	D0 (A)	6		7		8									
RS-485 (2-wire)																											
1																											
2																											
3																											
4	D1 (B)																										
5	D0 (A)																										
6																											
7																											
8																											
<b>11</b> <b>Double Ethernet ports LAN 1 and 2</b> 	10/100 Base-T RJ45 connectors Double ports dedicated to internal communication between T300 modules or for connection to a PC. Isolation: 2 kVac 10 Ethernet jumpers (Ref: EMS59528) provided as accessories allow the internal Ethernet connection between the HU250, SC150, SC160 and LV150 modules. See <i>LAN port NOTICE</i> .																										
<b>12</b> <b>Wi-Fi port</b> 	Dual-band concurrent Wi-Fi (2.4 GHz/5 GHz) <table border="1"> <thead> <tr> <th>Parameter</th> <th>Value</th> <th>Unit</th> </tr> </thead> <tbody> <tr> <td>Operating frequency range</td> <td>2400 - 2483.5</td> <td>MHz</td> </tr> <tr> <td>Maximum transmitted power</td> <td>18.2</td> <td>dBm</td> </tr> </tbody> </table> WI-Fi hotspot with security for local connection with a PC, a tablet or a smartphone to: <ul style="list-style-type: none"> <li>The T300 embedded Web server</li> <li>The Easergy Builder advanced configuration tool</li> </ul>	Parameter	Value	Unit	Operating frequency range	2400 - 2483.5	MHz	Maximum transmitted power	18.2	dBm																	
Parameter	Value	Unit																									
Operating frequency range	2400 - 2483.5	MHz																									
Maximum transmitted power	18.2	dBm																									

**Cabling**

Recommendation for length of cable less than 2 meters.

<b>5</b> 	8 mm 0.315 in	0.14-0.5 mm <sup>2</sup> 26-20 AWG	-
<b>9</b> 	7 mm 0.276 in	1-2.5 mm <sup>2</sup> 17 AWG	0.5-0.6 N.m 4.4-5.3 lb-in
<b>6</b> 	7 mm 0.276 in	0.5 mm <sup>2</sup> 20 AWG	0.22-0.25 N.m 1.9-2.2 lb-in
<b>7</b> 			
<b>8</b> 			

## Installation

### Installing the enclosure

The HU250 module is fastened to a DIN rail. No tool is needed for mounting. Simply clip it in order to fasten it as shown below.

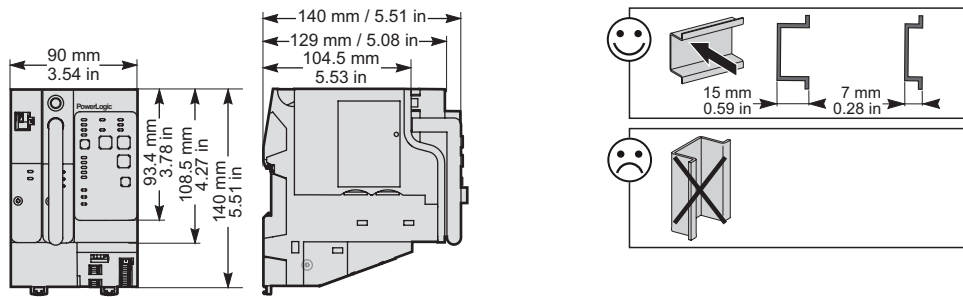

External dimensions of the HU250 enclosure

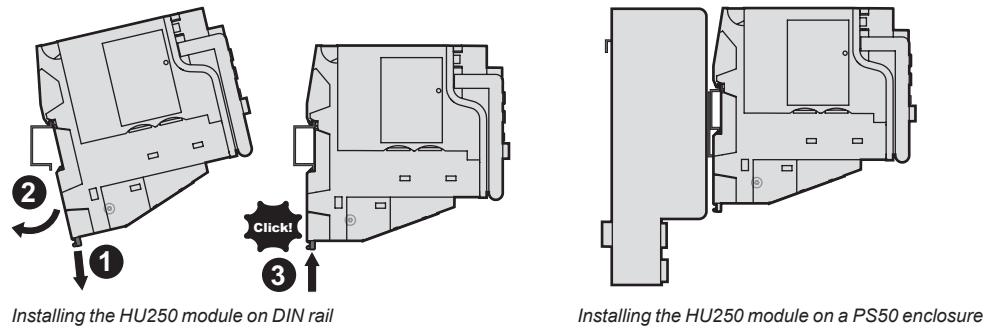

Installing the HU250 module on a DIN rail

Installing the HU250 module on a PS50 enclosure

### Installation of a modem box

Each modem box can be installed or interchanged easily and quickly in the HU250. The modem box is installed in factory, but if necessary it is possible to dismount it and replace it with another type of modem. To install a modem box:

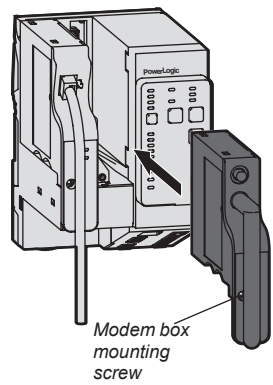

- Insert the SIM card(s) on the bottom of the modem (preferably with HU250 switched off).
- Install the modem box in the required slot on the HU250 (port 1 or port 2 slot).
- Press the front panel to insert the rear panel connector in the HU250 (be careful not to over-force during insertion).
- Tighten the screw on the front panel using a flat or Phillips-head screwdriver to fasten the modem box to the HU250.

To withdraw a modem box from its slot, perform the operation in reverse. **Note:** When changing a modem box it is also necessary to have the configuration changed by an expert using the Easergy Builder advanced configuration tool. To do so, refer to the *Easergy Builder User Guide*.

### Operation

Once the HU250 module has been powered up, some indicator lamps on the front panel may be lit to indicate certain operating states. The buttons allow the user to perform actions. These indications and actions are summarized in the table below:

Part	Description of indications and actions
<b>1</b>	<p><b>HU250 states</b></p> <ul style="list-style-type: none"> <li>1.1 HU250 operating</li> <li>1.2 Equipment status</li> <li>1.3 Wi-Fi access operating (activated by Local mode)</li> <li>1.4 Communication status with modules (SC150, SC160, LV150, PS50, for instance)</li> </ul>
<b>2</b>	<p><b>Local/Remote</b></p> <ul style="list-style-type: none"> <li>2.1 Remote position: all local controls on switches via the SCxxx module are locked (via the front panel and Wi-Fi)</li> <li>2.2 Local position: all remote controls are locked</li> <li>2.3 Push button that can be used to change Local/Remote state</li> </ul> <p><b>Note:</b> Switching to local mode activates Wi-Fi access.</p>
<b>3 and 8</b>	<p><b>Automatic control states and checks</b></p> <ul style="list-style-type: none"> <li>3.1 Automatic control enabled</li> <li>3.2 Automatic control disabled</li> <li>3.3 Automatic control locked</li> <li>3.4 Automatic control change-of-state button (ON/OFF)</li> <li>8.1 Change-of-state enabling button. The two buttons, change of state and enabling, must be pressed simultaneously for the change of state to take place. This change is performed simultaneously on all the T300 modules using automatic control functions.</li> </ul> <p><b>Note:</b> Change of state of the automatic control system by means of the buttons is possible only in Local mode.</p>
<b>4</b>	<p><b>Power supply</b></p> <ul style="list-style-type: none"> <li>4.1 Mains power supply operating</li> <li>4.2 48 V/24 V motor pack power supply operating</li> <li>4.3 Transmission equipment power supply operating</li> <li>4.4 Over consumption on transmission equipment power supply</li> <li>4.5 Battery status</li> </ul> <p><b>Note:</b> These states correspond to information retransmitted by the PS50 module via Modbus communication between modules. When another type of power supply module is used, these indicators can be customized by configuration via the Easergy Builder advanced configuration tool.</p>
<b>5</b>	<p><b>Customizable indicator lamps</b></p> <ul style="list-style-type: none"> <li>5.1, 5.2, 5.3 3 unassigned indicator lamps configurable for indication of customized states</li> </ul> <p><b>Note:</b> Customization of these indicators is performed via the Easergy Builder advanced configuration tool. Refer to the <i>PowerLogic T300 Quick Start Guide</i>.</p>
<b>6</b>	<p><b>GPRS or 4G or Zigbee receiver modem box indicator lamps</b></p> <ul style="list-style-type: none"> <li>6.1 Indicator of activity on the mobile or Zigbee network. This indicator flashes in particular during a research of network or a data transfer, and, for Zigbee protocol, when commissioning the device.</li> <li>6.2 Modem status indicator lamp: lights for a SIM card status or to indicate a problem of connection to the mobile or Zigbee network (low level of reception, for instance)</li> <li>6.3 GPS signal reception status indicator (only for modem boxes with GPS).</li> </ul>
<b>7</b>	<p><b>RS232-RS485 modem box indicator</b></p> <ul style="list-style-type: none"> <li>7.1 TX: RS-232/RS-485 data transmission indicator lamp</li> <li>7.2 RX: RS-232/RS-485 data reception indicator lamp</li> </ul>
<b>9</b>	<p><b>Reset</b></p> <ul style="list-style-type: none"> <li>9.1 Reset button reinitializing all fault current indications on all the SCxxx modules and automatic control locking</li> </ul>
<b>10</b>	<p><b>Indicator test</b></p> <ul style="list-style-type: none"> <li>10.1 Indicator test button for forced setting of lighting of all indicator lamps on the front panel of the T300 modules and the external indicator lamp. Makes it possible to detect any anomaly concerning the indicator lamps.</li> </ul>

**Note:** Refer to the table opposite for the meaning of the flashing states and the various possible colors for indicator lamps. Some indicators can be customized by configuration.

### GPRS or 4G modem

This modem allows a SIM card to be inserted in one of the two available SIM card slots, without there being any difference at the operating level.

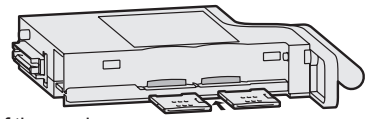

The GPS and GSM antenna connectors are accessible on the front of the modem.

Mounting the GPS antenna:

- Attach the GPS antenna to the wall of the substation (preferably outside).
- Connect the antenna cable to the modem connector marked *GPS*.

**Note:** The GSM antenna requires no outside mounting. It is a short antenna connected to the modem itself. This antenna is installed in factory.

### ⚠ DANGER

#### HAZARD OF ELECTRIC SHOCK, EXPLOSION OR ARC FLASH

- Wear your personal protective equipment (PPE) and comply with the safe electrical work practices. See NFPA 70E in the USA or applicable local standards.
- Only qualified person should install this equipment. Such work should be performed only after reading this entire set of instructions.
- Switch off the electric power supply of the HU250 and of all the devices to which the HU250 is connected before any handling or replacement operation.
- Always use a properly rated voltage sensing device to confirm that all power is off.

**Failure to follow these instructions will result in death or serious injury.**

### Power supply

The HU250 includes two connectors to connect the power supply. These two connectors are connected together internally in the HU250. Having two power supply connections can facilitate connection between the modules. No strapping is necessary. Connect the HU250 as shown in the following diagram.

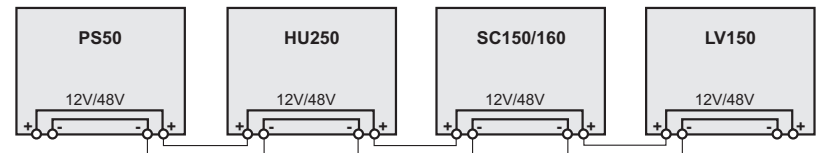

### Parameter settings

Installation of the HU250 module requires no parameters setup. This is performed during the commissioning/configuration stages.

Refer to the *PowerLogic T300 User Manual* and *Quick Start Guide* for any further information.

### Identification

The serial number of the HU250 is formed as follows: **PPYYWWDLLLNNNNN**.

Characters	Description
PP	Characters [A-Z,0-9]. Unique code of the manufacturing plant code. ME= India. SM = Latvia.
YYWW	Numbers [01-12, 01-52]. Datecode (year and week).
D	Number [1-7]. Day of the week, 1 representing Monday, 7 representing Sunday.
LLL	Characters [A-Z,0-9]. Unique code of the manufacturing line.
NNNNN	Numbers [00001-99999]. Unique number of the manufactured product.

### Grounding

The HU250 module must be connected to the ground via the mounting DIN rail. The DIN rail helps ensure electrical continuity (preferably use a DIN rail in 304L stainless steel to withstand the climatic conditions).

### NOTICE

#### HAZARD OF INCORRECT CURRENT MEASUREMENTS

- The DIN rail on which the HU250 is installed must be grounded and of metallic type and must comply with electrical continuity in all climatic conditions.
- If the HU250 is installed on a PS50 power supply module, the grounding of the module is done via the PS50 DIN rail, which must be grounded via a dedicated terminal near the PS50 power input connector. Refer to the *PS50 power supply Installation Guide*.

**Failure to follow these instructions can result in equipment damage.**

### Indicator lamp states

Indicator state	Flashing		Steady			Unit
	Red	Green	Red	Green	Orange	
<b>1</b>						
1.1	ON	Boot	-	-	-	-
1.2	ON	-	-	-	-	Major fault
1.3	ON	-	-	-	-	Minor fault
1.4	ON	-	-	-	-	In progress
<b>2</b>						
2.1	ON	-	-	-	-	Remote
2.2	ON	-	-	-	-	Local
<b>3</b>						
3.1	ON	-	-	-	-	ON
3.2	OFF	-	-	-	-	OFF
3.3	ON	-	-	-	-	Locked
<b>4</b>						
4.1	AC Supply	-	-	-	-	AC OFF
4.2	48V/24V	-	-	-	-	AC ON
4.3	12V	-	-	-	-	Fault
4.4	EXT	-	-	-	-	Fault
4.5	EXT	-	-	-	-	Fault
<b>5</b>						
5.1	ON	-	-	-	-	ON
5.2	ON	-	-	-	-	ON
5.3	ON	-	-	-	-	ON
<b>6</b>						
6.1	ON	-	-	-	-	Active
6.2	ON	-	-	-	-	Active and sync
6.3	ON	-	-	-	-	No sync
<b>7</b>						
7.1	TX	-	-	-	-	Transmitting
7.2	RX	-	-	-	-	Receiving
<b>9</b>						
9.1	ON	-	-	-	-	commissioning
9.2	ON	-	-	-	-	Fault
<b>10</b>						
10.1	ON	-	-	-	-	Inactive
10.2	ON	-	-	-	-	Inactive

(1) Indicators customizable by configuration. Only default values shown.

**Note:** The indications in bold letters correspond to normal operation (first power up without existence of a potential issue indication).

### NOTE

PowerLogic HU250, FCC ID: 2AHHK-POWERLOGIC250

This equipment has been tested and found to comply with the limits for a Class B digital device, pursuant to part 15 of the FCC Rules. These limits are designed to provide reasonable protection against harmful interference in a residential installation. This equipment generates, uses and can radiate radio frequency energy and, if not installed and used in accordance with the instruction, may cause harmful interference to radio communications. However, there is no guarantee that interference will not occur in a particular installation. If this equipment does cause harmful interference to radio or television reception which can be determined by turning the equipment off and on, the user is encouraged to try to correct interference by one or more of the following measures:

- Reorient or relocate the receiving antenna.
- Increase the separation between the equipment and receiver.
- Connect the equipment into an outlet on a circuit different from that to which the receiver is connected.
- Consult the dealer or an experienced radio/TV technician for help.

This device complies with FCC RF radiation exposure limits set forth for general population. This device must be installed to provide a separation distance of at least 20 cm (7.88 in) from all persons and must not be co-located or operating in conjunction with any other antenna or transmitter.

**Schneider Electric**  
35 rue Joseph Monier  
92500 Rueil Malmaison  
France  
Phone: +33 (0)1 41 29 70 00  
www.se.com

**Schneider Electric Limited**  
Stafford Park 5  
Telford, TF3 3BL  
United Kingdom

As standards, specifications and designs change from time to time, always ask for confirmation of the information given in this publication.

Publication: Schneider Electric  
Production: Schneider Electric  
Printing: Schneider Electric

This document was printed on environmentally friendly paper

© 2015-2025 Schneider Electric. All Rights Reserved.  
NHA77925-12