





TEST REPORT

Report Number: C21T00097-EMC01-V01

Applicant	Shanghai Sunmi Technology Co.,Ltd.
Product Name	Handheld Wireless Terminal
Model Name	T8A10
Brand Name	SUNMI
FCC ID	2AH25T8A10

Industrial Internet Innovation Center (Shanghai) Co., Ltd. tested the above equipment in accordance with the requirements in FCC Part 15, Subpart B, ANSI C63.4-2014.

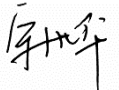
Prepared by		Reviewed by	
Approved by		Issue Date	2021-12-16

Industrial Internet Innovation Center (Shanghai) Co., Ltd.



NOTE

1. This report is invalid without the signature of the writer, reviewer and authorizer.
2. This report is invalid if altered.
3. For the benefit of clients, if you have any objection to the report, please inform the testing laboratory within 15 days from the date of receiving this report.
4. Samples in the test report are provided by the client. The test results are only applicable to the samples received by the laboratory. The source information of samples (such as sample sender, manufacturer, etc.) in the test report is provided by the client, and the laboratory is not responsible for its authenticity and the measurement accuracy.
5. The test report does not represent the identification of a product by a certification body or an authorized body.
6. This report is only valid as a whole, and no part of the report can be reproduced without the written approval of Industrial Internet Innovation Center (Shanghai) Co., Ltd.
7. Without the written permission of testing institutions and accreditation bodies, this report cannot be used in part or in whole for publicity or product introduction.
8. "N/A" is used in this report to indicate that it is not applicable or available.
9. Industrial Internet Innovation Center (Shanghai) Co., Ltd. assumes the legal responsibility for the report.
10. The measurement uncertainty is not taken into account when deciding conformity, and the results of measurement (or the average of measurement results) are directly used as the criterion for the stating conformity.

Test Laboratory:

Industrial Internet Innovation Center (Shanghai) Co., Ltd.

Add: Building 4, No. 766 Jingang Rd, Pudong, Shanghai, China

Tel: +86 21 68866880



Revision Version

Report Number	Revision	Date	Memo
C21T00097-EMC01-V00	00	2021-12-09	Initial creation of test report
C21T00097-EMC01-V01	01	2021-12-16	Deleting IC Information



CONTENTS

1. TEST LABORATORY	5
1.1. TESTING LOCATION	5
1.2. TESTING ENVIRONMENT	5
1.3. PROJECT INFORMATION	5
2. CLIENT INFORMATION	6
2.1. APPLICANT INFORMATION	6
2.2. MANUFACTURER INFORMATION	6
3. EQUIPMENT UNDER TEST (EUT) AND ANCILLARY EQUIPMENT (AE)	7
3.1. ABOUT EUT	7
3.2. INTERNAL IDENTIFICATION OF EUT USED DURING THE TEST	7
3.3. INTERNAL IDENTIFICATION OF AE USED DURING THE TEST	7
4. REFERENCE DOCUMENTS	9
4.1. REFERENCE DOCUMENTS FOR TESTING	9
5. TEST SUMMARY	10
5.1. SUMMARY OF TEST RESULTS	10
5.2. STATEMENTS	10
5.3. DECISION OF FINAL TEST MODE	11
5.4. EUT CONNECTION DIAGRAM OF TEST SYSTEM	12
6. MEASUREMENT RESULTS	13
6.1. RADIATED EMISSION	13
6.2. AC CONDUCTED EMISSION	17
7. TEST EQUIPMENT LIST	19
ANNEX A: MEASUREMENT UNCERTAIN	20
ANNEX B: ACCREDITATION CERTIFICATE	21



1. Test Laboratory

1.1. Testing Location

Primary Lab:

Company Name	Industrial Internet Innovation Center (Shanghai) Co., Ltd.
Address	Building 4, No. 766 Jingang Rd, Pudong, Shanghai, China
FCC Registration No.	958356
FCC Designation No.	CN1177

1.2. Testing Environment

Normal Temperature	15°C~35°C
Relative Humidity	30%RH~60%RH
Supply Voltage	120V/60Hz

1.3. Project Information

Project Leader	Wang Wenwen
Testing Start Date	2021-08-06
Testing End Date	2021-09-16



2. Client Information

2.1. Applicant Information

Company Name	Shanghai Sunmi Technology Co.,Ltd.
Address	Room 505, KIC Plaza, No.388 Song Hu Road, Yang Pu District, Shanghai, China
Telephone	+86 18501703215

2.2. Manufacturer Information

Company Name	Shanghai Sunmi Technology Co.,Ltd.
Address	Room 505, KIC Plaza, No.388 Song Hu Road, Yang Pu District, Shanghai, China
Telephone	+86 18501703215

3. Equipment under Test (EUT) and Ancillary Equipment (AE)

3.1. About EUT

Product Name	Handheld Wireless Terminal
Model name	T8A10
Supported Radio Technology and Bands	GSM850/GSM900/GSM1800/GSM1900 WCDMA Band I /Band II /BandIV/Band V /BandVIII LTE 1/2/3/4/5/7/12/13/17/18/19/25/26/28/38/40/41/66/71 BT5.0 WLAN 802.11b,g,n WLAN 802.11a,n,ac NFC GPS GLONASS Galileo BDS
Hardware Version	V4
Software Version	V025

Note: Photographs of EUT are shown in ANNEX B of this test report.

3.2. Internal Identification of EUT used during the test

EUT ID*	SN or IMEI	HW Version	SW Version	Date of Receipt
N08	866584051015747	V4	V025	2021/08/04

*EUT ID: is internally used to identify the test sample in the lab.

3.3. Internal Identification of AE used during the test

AE ID*	Description	Model	SN/Remark
CA01	Adapter	CK18W02U	N/A
CB02	Adapter	TPA-10120150UU	N/A
UA02	USB Cable	USB A TO C+PTC 1.5M	N/A
BA10	Battery	JKRA	N/A
AE1	Notebook PC	DELL Latitude E6510	N/A
AE2	Desktop PC	OptiPlex 790 DT	X8RP1 A01 APCC
AE3	LAN Cable	N/A	N/A
AE4	VGA Cable	N/A	N/A
AE5	RS232 Cable	N/A	N/A

AE6	Keyboard	KB212-B	CN-0Y88XT-65890-12I-005Q-A00
AE7	Mouse	MS111-P	CN-011D3V-71581-19J-1A64
AE8	Monitor	Dell E1709Wc	N/A
AE9	Micro SD Card	Kingston SDC4/4GB 77	N/A

*AE ID: is internally used to identify the test sample in the lab.

*The AE is provided by the lab.

4. Reference Documents

4.1. Reference Documents for testing

The following documents listed in this section are referred for testing.

Reference	Title	Version
FCC Part 15, Subpart B	Radio frequency devices	2020/10/1
ANSI C63.4	Method of Measurement of Radio-Noise Emissions from Low-Voltage Electrical and Electronic Equipment in the Range of 9 kHz to 40 GHz	2014

5. Test Summary

5.1. Summary of Test Results

Items	Test List	Standard	Verdict
1	Radiated Emission	15.109(a)	Pass
2	AC Conducted Emission	15.107(a)	Pass

5.2. Statements

The T8A10, manufactured by Shanghai Sunmi Technology Co.,Ltd. is a new product for testing.

Industrial Internet Innovation Center (Shanghai) Co., Ltd. only performed test cases which identified with Pass/Fail/Inc result in section 5.1.

Industrial Internet Innovation Center (Shanghai) Co., Ltd. has verified that the compliance of the tested device specified in section 3 of this test report is successfully evaluated according to the procedure and test methods as defined in type certification requirement listed in section 4 of this test report.

5.3. Decision of final test mode

The EUT was tested together with the above additional components, and a configuration, which produced the worst emission levels, was selected and recorded in this report.

The test configuration modes are as the following:

Test Item	Test setup and operating modes
Radiated emission	Mode 1: Adapter charging+ G850 receiver mode + Front Camera+ CA01+UA02 Mode 2: Adapter charging+ G850 receiver mode + Back Camera+ CB02+UA02 Mode 3: DATA LINK mode (PC to SD) +UA02 Mode 4: DATA LINK mode (SD to PC) +UA02 Mode 5: Scan mode Mode 6: GPS mode Mode 7: GLONASS mode Mode 8: Galileo mode Mode 9: BDS mode
AC Conducted Emission	Mode 1: Adapter charging+ G850 receiver mode + Front Camera+ CA01+UA02 Mode 2: Adapter charging+ G850 receiver mode + Back Camera+ CB02+UA02 Mode 3: DATA LINK mode (PC to SD) +UA02 Mode 4: DATA LINK mode (SD to PC) +UA02 Mode 6: GPS mode Mode 7: GLONASS mode Mode 8: Galileo mode Mode 9: BDS mode
Remark: 1. All test modes are performed, only the worst cases test data are recorded in this report. 2. After laboratory verification, GSM850 is the worst mode among all receiving modes of 2G/3G/4G and is recorded in the report. 3. Data Link with PC means data application transferred mode between EUT and PC. 4. EUT and GNSS simulator (SMBV100A) connection is established. 5. EUT and bar code remain in sweep state.	

5.4. EUT Connection Diagram of Test System

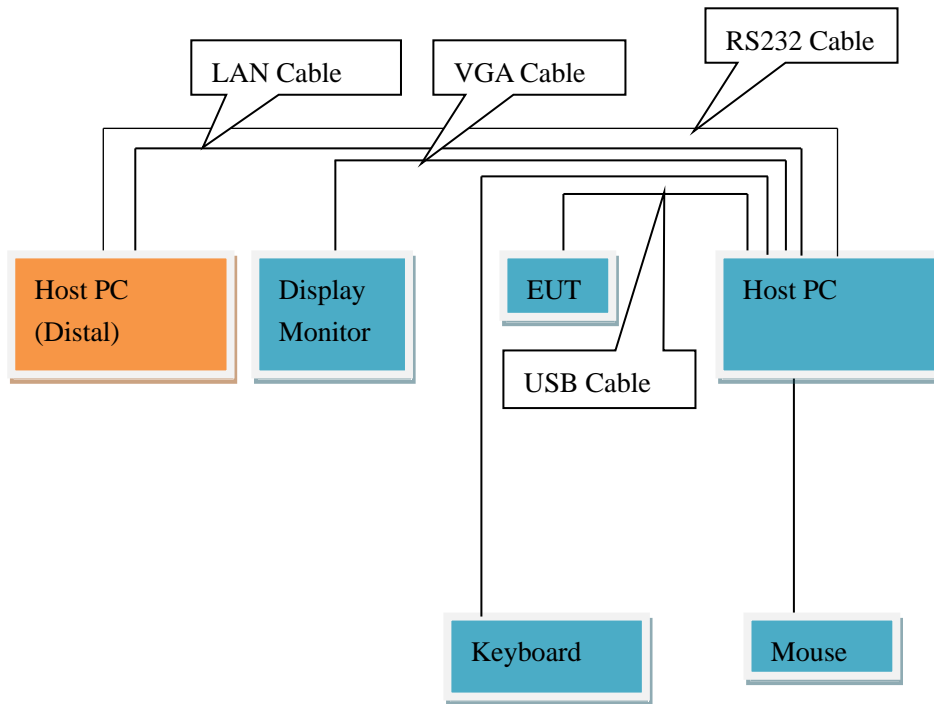

<Figure 1> Mode 3,4

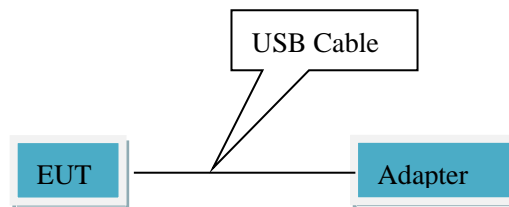

<Figure 2> Mode 1~2,6~9



<Figure 3> Mode 5

6. Measurement Results

6.1. Radiated Emission

Method of Measurement

- a. For 30MHz -1000MHz, the EUT was placed on the top of a rotating 0.8m table above the ground at a semi-anechoic chamber. The distance between the EUT and the received antenna was 3 meters. The table was rotated 360 degree and the received antenna mounted on a variable-height antenna tower was varied from 1m to 4m to find the maximum value of the field strength. Both horizontal and vertical polarizations of the antenna were set during the measurement.
- b. For 1000MHz-18000MHz, the maximal emission value was acquired by adjusting the antenna height, the table was rotated 360 degree to determine the maximum value of the field strength. Both horizontal and vertical polarizations of the antenna were set during the measurement.

Limits for Radiated Emission at a measuring distance of 3m

Table 1:

Frequency Range (MHz)	Quasi-Peak (dB μ V/m)
30-88	40
88-216	43.5
216-960	46
Above 960	54

Table 2:

Frequency Range (MHz)	Peak (dB μ V/m)	Average (dB μ V/m)
Above 1000	74	54

Table 3:

Test conditions

Frequency Range (MHz)	RBW/VBW	Sweep Time (s)
30-1000	120kHz/300kHz	Auto
1000-18000	1MHz/3MHz	Auto

Test Results

Sweep the whole frequency band through the range from 30MHz to the 5th harmonic of the carrier, the Emissions in the frequency band 18GHz-40GHz is more than 20dB below the limit are not report.

Mode 3: DATA LINK mode (PC to SD) +UA02 (30M-1GHz)

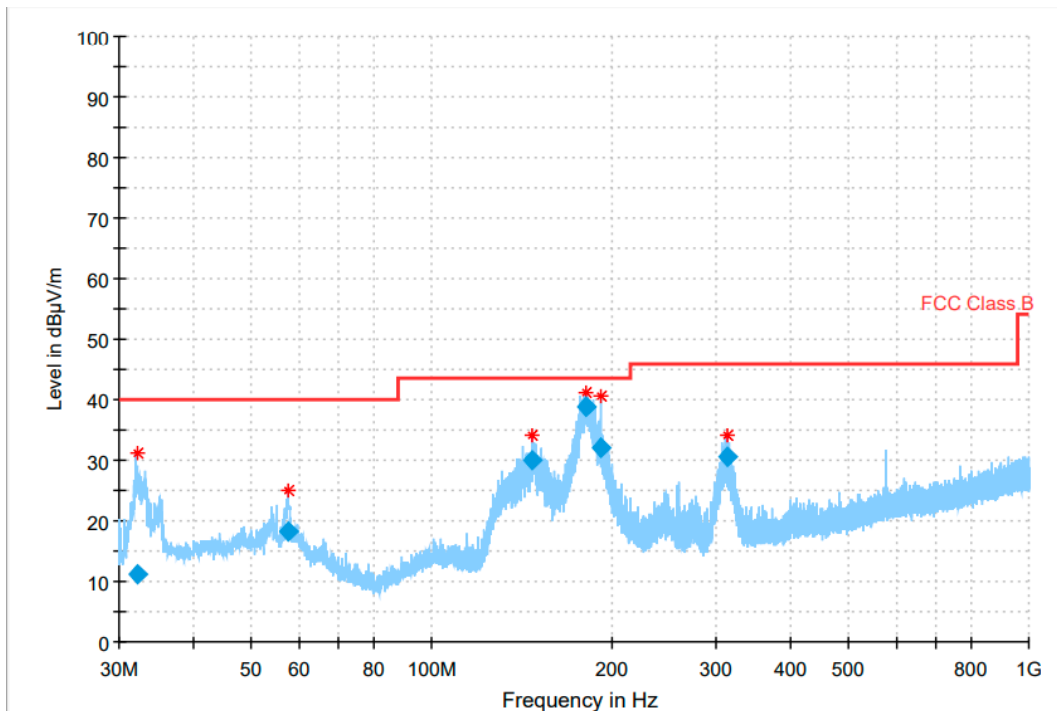

Final Result 1

Frequency (MHz)	QuasiPeak (dBµV/m)	Limit (dBµV/m)	Margin (dB)	Meas. Time (ms)	Bandwidth (kHz)	Height (cm)	Pol	Azimuth (deg)	Corr. (dB)
32.122381	11.11	40.00	28.89	1000.0	120.000	100.0	H	184.0	-14.4
57.504477	18.09	40.00	21.91	1000.0	120.000	222.0	V	136.0	-12.2
147.065592	30.10	43.50	13.40	1000.0	120.000	100.0	H	69.0	-17.1
181.157947	38.76	43.50	4.74	1000.0	120.000	100.0	H	-1.0	-14.8
192.123701	32.18	43.50	11.32	1000.0	120.000	100.0	H	130.0	-14.3
313.080309	30.58	46.00	15.42	1000.0	120.000	124.0	V	167.0	-10.4

Note:

1. Emission level(QP)=Raw value by receiver + Corr(Antenna factor + cable loss - preamplifier gain)
2. The raw value is used to calculate by software which is not shown in the sheet.
3. Margin=limit value – emission level.

Mode 3: DATA LINK mode (PC to SD) +UA02 (1GHz-18GHz)

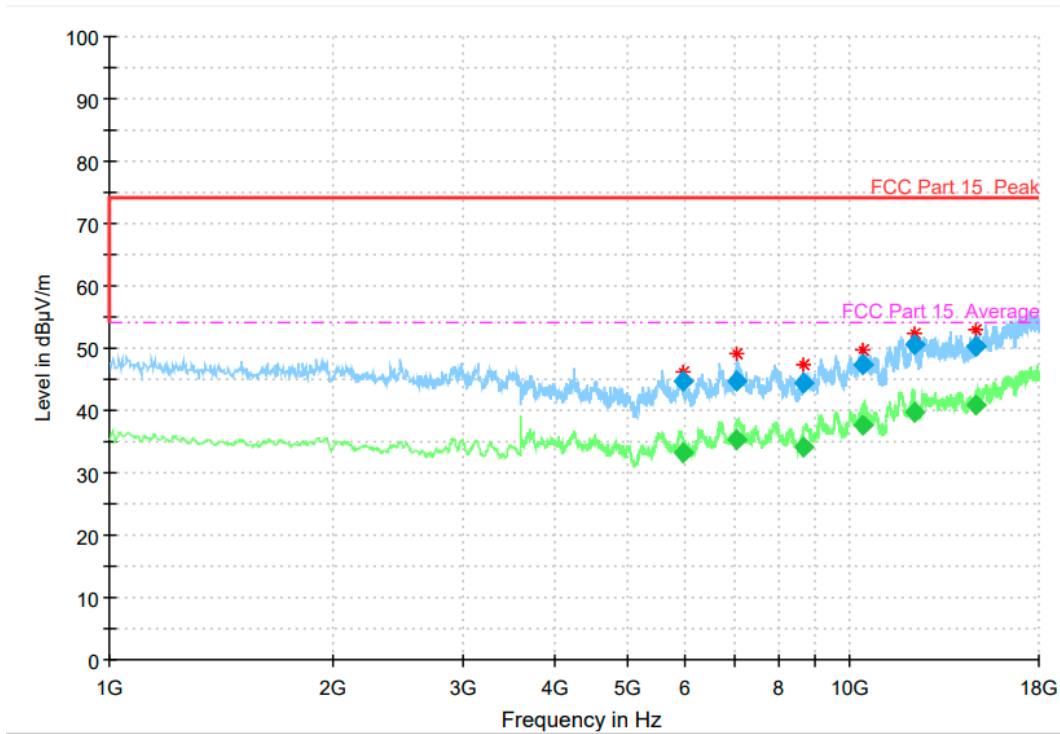

Final Result 1

Frequency (MHz)	MaxPeak (dBµV/m)	Average (dBµV/m)	Limit (dBµV/m)	Margin (dB)	Meas. Time (ms)	Bandwidth (kHz)	Height (cm)	Pol	Azimuth (deg)	Corr. (dB)
5939.80000	44.67	---	74.00	29.33	1.0	1000.00	200.0	H	305.0	2.3
5939.80000	---	33.33	54.00	20.67	1.0	1000.00	200.0	H	305.0	2.3
7053.00000	44.69	---	74.00	29.31	1.0	1000.00	200.0	H	245.0	4.4
7053.00000	---	35.19	54.00	18.81	1.0	1000.00	200.0	H	245.0	4.4
8677.20000	---	34.03	54.00	19.97	1.0	1000.00	200.0	H	132.0	3.8
8677.20000	44.55	---	74.00	29.45	1.0	1000.00	200.0	H	132.0	3.8
10430.80000	47.23	---	74.00	26.77	1.0	1000.00	100.0	H	100.0	7.6
10430.80000	---	37.56	54.00	16.44	1.0	1000.00	100.0	H	100.0	7.6
12199.40000	---	39.71	54.00	14.29	1.0	1000.00	200.0	H	287.0	10.7
12199.40000	50.55	---	74.00	23.45	1.0	1000.00	200.0	H	287.0	10.7
14825.40000	50.26	---	74.00	23.74	1.0	1000.00	200.0	H	0.0	13.9
14825.40000	---	40.95	54.00	13.05	1.0	1000.00	200.0	H	0.0	13.9

Note:

1. Emission level (peak or average)=Raw value by receiver + Corr (Antenna factor+ cable loss- preamplifier gain)
2. The raw value is used to calculate by software which is not shown in the sheet.
3. Margin=limit value – emission level.

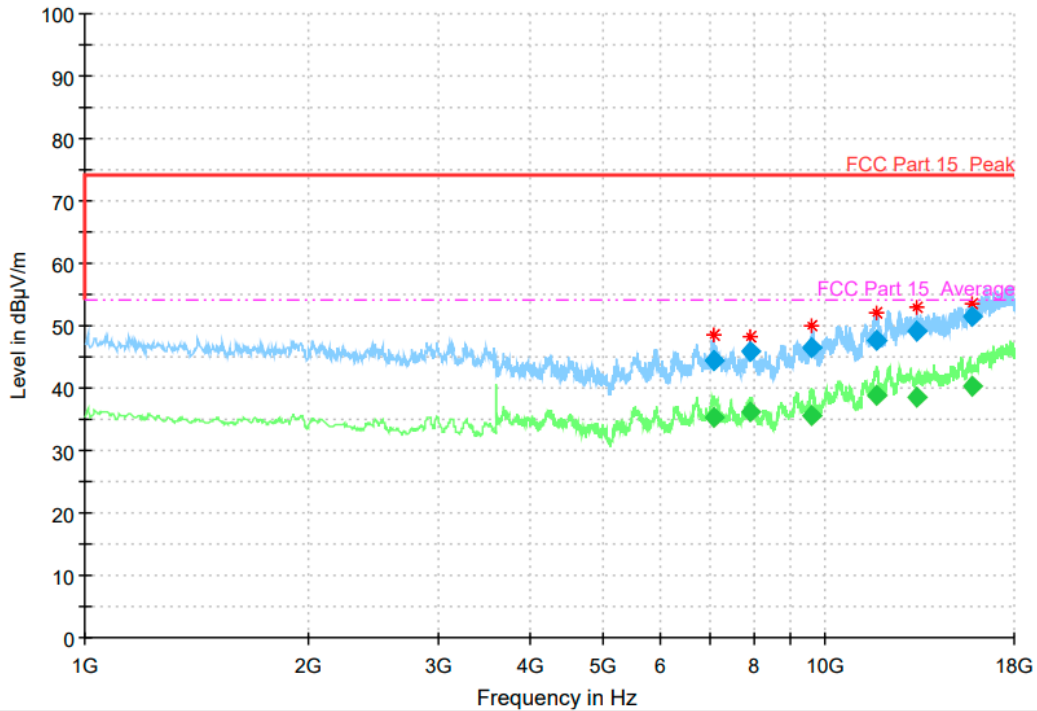

Final Result 1

Frequency (MHz)	MaxPeak (dBµV/m)	Average (dBµV/m)	Limit (dBµV/m)	Margin (dB)	Meas. Time (ms)	Band width (kHz)	Height (cm)	Pol	Azimuth (deg)	Corr. (dB)
7079.60000	---	35.28	54.00	18.72	1.0	1000.000	100.0	V	0.0	4.3
7079.60000	44.29	---	74.00	29.71	1.0	1000.000	100.0	V	0.0	4.3
7916.00000	---	36.06	54.00	17.94	1.0	1000.000	100.0	V	141.0	4.5
7916.00000	45.85	---	74.00	28.15	1.0	1000.000	100.0	V	141.0	4.5
9608.80000	---	35.60	54.00	18.40	1.0	1000.000	100.0	V	141.0	5.8
9608.80000	46.56	---	74.00	27.44	1.0	1000.000	100.0	V	141.0	5.8
11703.4000	47.60	---	74.00	26.40	1.0	1000.000	200.0	V	135.0	10.0
11703.4000	---	38.80	54.00	15.20	1.0	1000.000	200.0	V	135.0	10.0
13308.6000	49.00	---	74.00	25.00	1.0	1000.000	100.0	V	234.0	11.3
13308.6000	---	38.52	54.00	15.48	1.0	1000.000	100.0	V	234.0	11.3
15748.4000	---	40.20	54.00	13.80	1.0	1000.000	200.0	V	32.0	14.7
15748.4000	51.44	---	74.00	22.56	1.0	1000.000	200.0	V	32.0	14.7

Note:

1. Emission level (peak or average) = Raw value by receiver + Corr (Antenna factor+ cable loss- preamplifier gain)
2. The raw value is used to calculate by software which is not shown in the sheet.
3. Margin=limit value – emission level.

6.2. AC Conducted Emission

Method of Measurement

For equipment that is designed to be connected to the public utility (AC) power line, the radio frequency voltage that is conducted back onto the AC power line on any frequency or frequencies with the band 150 kHz to 30MHz shall not exceed the limits. Both lines of the power mains connected to the EUT were checked for maximum conducted interference. Tested in accordance with the procedures of ANSI C63.4-2014, section 7.3

Limit of AC Conducted Emission

Frequency Range (MHz)	Conducted Limit (dBuV)	
	Quasi-peak	Average
0.15-0.5	66 to 56*	56 to 46*
0.5-5	56	46
5-30	60	50

*Decreases with the logarithm of the frequency

Test Condition in Charging Mode

Voltage (V)	Frequency (Hz)	RBW	Sweep Time (s)
120	60	9 kHz	Auto

Test Results

Mode 2: Adapter charging+ G850 receiver mode + Back Camera+ CB02+UA02

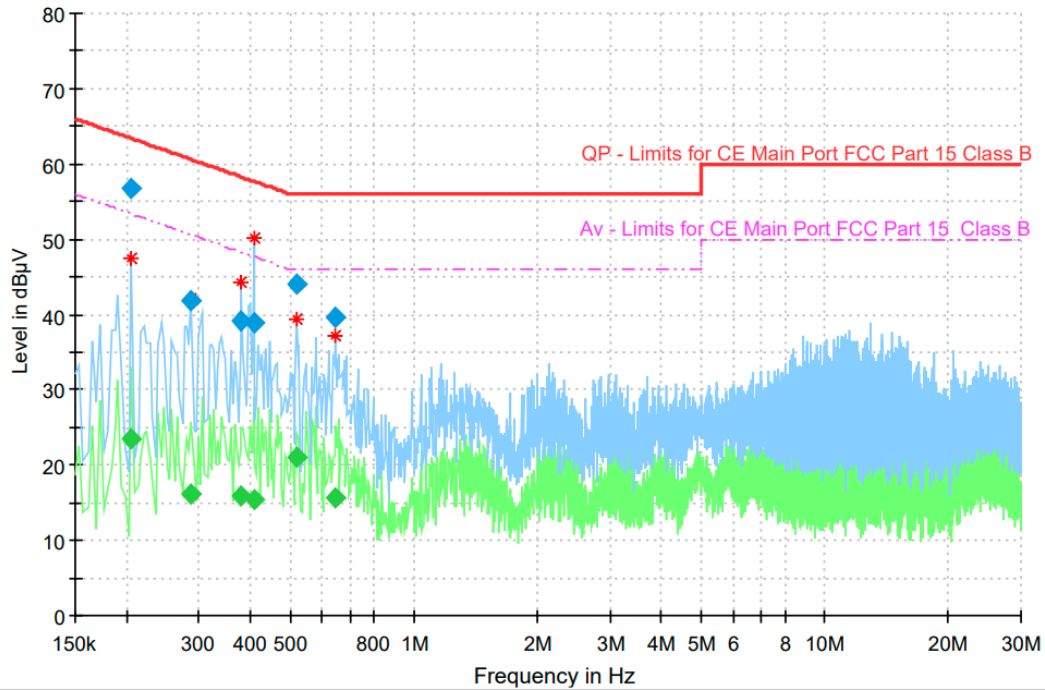

Final Result 1

Frequency (MHz)	QuasiPeak (dB µ V)	Average (dB µ V)	Limit (dB µ V)	Margin (dB)	Meas. Time (ms)	Bandwidth (kHz)	Line	Filter	Corr. (dB)
0.205969	---	23.38	53.37	29.99	15000.0	9.000	L1	ON	9.6
0.205969	56.77	---	63.37	6.59	15000.0	9.000	L1	ON	9.6
0.288056	---	16.10	50.58	34.48	15000.0	9.000	L1	ON	9.6
0.288056	41.79	---	60.58	18.79	15000.0	9.000	L1	ON	9.6
0.381338	---	15.87	48.25	32.38	15000.0	9.000	L1	ON	9.6
0.381338	39.19	---	58.25	19.06	15000.0	9.000	L1	ON	9.6
0.407456	---	15.40	47.70	32.30	15000.0	9.000	L1	ON	9.6
0.407456	38.87	---	57.70	18.83	15000.0	9.000	L1	ON	9.6
0.519394	44.15	---	56.00	11.85	15000.0	9.000	N	ON	9.6
0.519394	---	21.00	46.00	25.00	15000.0	9.000	N	ON	9.6
0.646256	39.71	---	56.00	16.29	15000.0	9.000	L1	ON	9.6
0.646256	---	15.58	46.00	30.42	15000.0	9.000	L1	ON	9.6

Note:

1. Emission level(quasi-peak or Average peak)=Raw value by receiver + Corr(Insertion loss+ cable loss)
2. The raw value is used to calculate by software which is not shown in the sheet.
3. Margin=limit value – emission level.
4. L1 and N line is all have been tested, the result of them is synthesized in the above data diagram.

7. Test Equipment List

7.1. Radiated Emission Equipment list

Item	Equipment Name	Type	Serial Number	Manufacturer	Cal. Date	Cal. interval
1	Test Receiver	ESU40	100307	R&S	2021-03-03	1 year
2	Universal Radio Communication Tester	CMU200	123102	R&S	2021-05-10	1 year
3	Universal Radio Communication Tester	CMW500	104178	R&S	2021-05-10	1 year
4	Trilog Antenna	VULB9163	VULB9163-515	Schwarzbeck	2021-02-03	2 years
5	Double Ridged Guide Antenna	ETS-3117	00135890	ETS	2020-02-28	2 years
6	EMI Test Software	EMC32 V9.15	N/A	R&S	N/A	N/A
7	Signal Generator	SMBV100A	257984	R&S	2021-03-03	1 year

7.2. AC Conducted Emission Equipment list

Item	Equipment Name	Type	Serial Number	Manufacturer	Cal. Date	Cal. interval
1	Test Receiver	ESCI	101235	R&S	2021-05-10	1 year
2	Universal Radio Communication Tester	CMU200	123102	R&S	2021-05-10	1 year
3	Universal Radio Communication Tester	CMW500	104178	R&S	2021-05-10	1 year
4	2-Line V-Network	ENV216	101380	R&S	2021-03-20	1 year
5	EMI Test Software	EMC32 V10.35.02	N/A	R&S	N/A	N/A
6	Signal Generator	SMBV100A	257984	R&S	2021-03-03	1 year



Annex A: Measurement Uncertain

This uncertainty represents an expanded uncertainty expressed at approximately the 95% confidence level using a coverage factor of $k=2$.

Case	Uncertainty
Radiated Emission 30MHz-1000MHz	4.96 dB
Radiated Emission 1000MHz-18000MHz	5.18 dB
AC Conducted Emission	3.66 dB

Annex B: Accreditation Certificate



Accredited Laboratory

A2LA has accredited

INDUSTRIAL INTERNET INNOVATION CENTER (SHANGHAI) CO., LTD.

Shanghai, People's Republic of China

for technical competence in the field of

Electrical Testing

This laboratory is accredited in accordance with the recognized International Standard ISO/IEC 17025:2017 General requirements for the competence of testing and calibration laboratories. This accreditation demonstrates technical competence for a defined scope and the operation of a laboratory quality management system (refer to joint ISO-ILAC-IAF Communiqué dated April 2017).



Presented this 12th day of April 2021.

Vice President, Accreditation Services
For the Accreditation Council
Certificate Number 3682.01
Valid to February 28, 2023

For the tests to which this accreditation applies, please refer to the laboratory's Electrical Scope of Accreditation.

*****END OF REPORT*****