

FCC RADIO TEST REPORT

FCC ID: 2AGSWMEU020DC27

Product:	WiFi connected digital frame for streaming art
Trade Name:	MEURAL
Model Name:	MEU020DC27
Serial Model:	MEU2LEOB27,MEU2WINS27,MEU2WHTCRD8FT

Prepared for

MEURAL Inc.
902 Broadway 6th Floor, New York NY, USA, 10010

Prepared by

Shenzhen ZCT Technology Co.,Ltd.
3/F., Building 5, Hongsheng Industrial Zone, Bao'an Road, Xixiang Street, Bao'an
Tel: +(86)-0755-23719050 Fax: +(86)-0755-23702323 Http: www.renzhengjiance.com.cn

TEST RESULT CERTIFICATION

TEST RESULT CERTIFICATION	
Manufacture's Name	Heng Gang Glover Optical Manufacturing
Address	No.23,Hong Mian Fourth Road Heng Gang,Long Gang District ShenZhen City,China
Product description	
Product name	WiFi connected digital frame for streaming art
Model and/or type reference	MEU020DC27
Additional Model	MEU2LEOB27,MEU2WINS27,MEU2WHTCRD8FT
Standards	FCC Part15.247
Test procedure.....	ANSI C63.10-2013
<p>This device described above has been tested by ZCT, and the test results show that the equipment under test (EUT) is in compliance with the FCC requirements. And it is applicable only to the tested sample identified in the report.</p> <p>This report shall not be reproduced except in full, without the written approval of ZCT, this document may be altered or revised by ZCT, personal only, and shall be noted in the revision of the document.</p>	
Date of Test	
Date (s) of performance of tests.....	June. 12 2017 ~June. 28 2017
Date of Issue.....	June. 29 2015
Test Result.....	Pass

Testing Engineer	:	
		(Anna Lv)
Authorized Signatory	:	
		(Tomy Wu)

Table of Contents	Page
1 . SUMMARY OF TEST RESULTS	6
TEST FACILITY	7
MEASUREMENT UNCERTAINTY	7
2 . GENERAL INFORMATION	8
GENERAL DESCRIPTION OF EUT	8
DESCRIPTION OF TEST MODES	10
TABLE OF PARAMETERS OF TEXT SOFTWARE SETTING	11
BLOCK DIGRAM SHOWING THE CONFIGURATION OF SYSTEM TESTED	11
DESCRIPTION OF SUPPORT UNITS(CONDUCTED MODE)	12
EQUIPMENTS LIST FOR ALL TEST ITEMS	13
3 . EMC EMISSION TEST	14
CONDUCTED EMISSION MEASUREMENT	14
POWER LINE CONDUCTED EMISSION LIMITS	14
TEST PROCEDURE	15
DEVIATION FROM TEST STANDARD	15
TEST SETUP	15
EUT OPERATING CONDITIONS	15
TEST RESULTS	15
RADIATED EMISSION MEASUREMENT	18
RADIATED EMISSION LIMITS	18
TEST PROCEDURE	19
DEVIATION FROM TEST STANDARD	19
TEST SETUP	20
EUT OPERATING CONDITIONS	21
TEST RESULTS (BELOW 30 MHZ)	22
TEST RESULTS (BETWEEN 30M – 1000 MHZ)	23
4 . NUMBER OF HOPPING CHANNEL	37
APPLIED PROCEDURES / LIMIT	37
TEST PROCEDURE	37
DEVIATION FROM STANDARD	37

Table of Contents		Page
TEST SETUP		37
EUT OPERATION CONDITIONS		37
TEST RESULTS		38
5 . AVERAGE TIME OF OCCUPANCY		40
APPLIED PROCEDURES / LIMIT		40
TEST PROCEDURE		40
DEVIATION FROM STANDARD		40
TEST SETUP		41
EUT OPERATION CONDITIONS		41
TEST RESULTS		42
6 . HOPPING CHANNEL SEPARATION MEASUREMENT		46
APPLIED PROCEDURES / LIMIT		46
TEST PROCEDURE		46
DEVIATION FROM STANDARD		46
TEST SETUP		46
EUT OPERATION CONDITIONS		46
TEST RESULTS		47
7 . BANDWIDTH TEST		51
APPLIED PROCEDURES / LIMIT		51
TEST PROCEDURE		51
DEVIATION FROM STANDARD		51
TEST SETUP		51
EUT OPERATION CONDITIONS		51
TEST RESULTS		52
8 . PEAK OUTPUT POWER TEST		56
APPLIED PROCEDURES / LIMIT		56
TEST PROCEDURE		56
DEVIATION FROM STANDARD		56
TEST SETUP		56
EUT OPERATION CONDITIONS		56
TEST RESULTS		57
9 . 100 KHZ BANDWIDTH OF FREQUENCY BAND EDGE		58

Table of Contents	Page
DEVIATION FROM STANDARD	58
TEST SETUP	59
EUT OPERATION CONDITIONS	59
TEST RESULTS	60
10 . ANTENNA REQUIREMENT	66
STANDARD REQUIREMENT	66
EUT ANTENNA	66
11 . EUT TEST PHOTO	67
APPENDIX-PHOTOGRAPHS OF EUT CONSTRUCTIONAL DETAILS	

1. SUMMARY OF TEST RESULTS

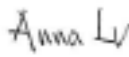
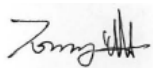
Test procedures according to the technical standards:

FCC Part15 (15.247) , Subpart C			
Standard Section	Test Item	Judgment	Remark
15.207	Conducted Emission	PASS	
15.247(a)(1)	Hopping Channel Separation	PASS	
15.247(b)(1)	Peak Output Power	PASS	
15.247(c)	Radiated Spurious Emission	PASS	
15.247(a)(iii)	Number of Hopping Frequency	PASS	
15.247(a)(iii)	Dwell Time	PASS	
15.247(a)(1)	Bandwidth	PASS	
15.205	Band Edge Emission	PASS	
15.203	Antenna Requirement	PASS	

NOTE:

(1) "N/A" denotes test is not applicable in this Test Report

1.1 TEST FACILITY

DongGuan Yaxu(AiT) Technology Limited
No. 22,JinQianLing Street 3, JiTiGang Village, Huang-Jiang Town, DongGuan, Guangdong,
523757 China

FCC Registration No.: 248337

1.2 MEASUREMENT UNCERTAINTY

The reported uncertainty of measurement $y \pm U$, where expanded uncertainty U is based on a standard uncertainty multiplied by a coverage factor of $k=2$, providing a level of confidence of approximately **95 %**.

No.	Item	Uncertainty
1	Conducted Emission Test	$\pm 1.38\text{dB}$
2	RF power,conducted	$\pm 0.16\text{dB}$
3	Spurious emissions,conducted	$\pm 0.21\text{dB}$
4	All emissions,radiated(<1G)	$\pm 4.68\text{dB}$
5	All emissions,radiated(>1G)	$\pm 4.89\text{dB}$
6	Temperature	$\pm 0.5^\circ\text{C}$
7	Humidity	$\pm 2\%$

2. GENERAL INFORMATION

GENERAL DESCRIPTION OF EUT

Equipment	WiFi connected digital frame for streaming art	
Model Name	MEU020DC27	
Serial number	N/A	
Serial Model	MEU2LEOB27,MEU2WINS27,MEU2WHTCRD8FT	
Model Difference	All models are identical except model name.	
Product Description	The EUT is a WiFi connected digital frame for streaming art	
	Operation Frequency:	2402~2480 MHz
	Bluetooth version:	2.1+EDR
	Modulation Type:	GFSK, ($\pi/4$)DQPSK, 8DPSK
	Bit Rate of Transmitter	1Mbps,2Mbps,3Mbps
	Number Of Channel	79 CH
	Antenna Designation:	Please see Note 3.
	Output Power(Conducted):	2.29 dBm PK
Based on the application, features, or specification exhibited in User's Manual, the EUT is considered as an ITE/Computing Device. More details of EUT technical specification, please refer to the User's Manual.		
Channel List	Please refer to the Note 2.	
Ratings	12Vdc from adapter,AC 120V/60Hz for adapter	
Adapter	Model: FJ-SW1204000U Input: 100-240V~50/60Hz 1.5A Output: 12Vdc 4000mA	
BZCTery	N/A	
Connecting I/O Port(s)	Please refer to the User's Manual	
hardware version	DPF21_20151013_V1.0	
Software version	V1.1	

Note:	
1.	For a more detailed features description, please refer to the manufacturer's specifications or the User's Manual.

2.

Channel List					
Channel	Frequency (MHz)	Channel	Frequency (MHz)	Channel	Frequency (MHz)
00	2402	27	2429	54	2456
01	2403	28	2430	55	2457
02	2404	29	2431	56	2458
03	2405	30	2432	57	2459
04	2406	31	2433	58	2460
05	2407	32	2434	59	2461
06	2408	33	2435	60	2462
07	2409	34	2436	61	2463
08	2410	35	2437	62	2464
09	2411	36	2438	63	2465
10	2412	37	2439	64	2466
11	2413	38	2440	65	2467
12	2414	39	2441	66	2468
13	2415	40	2442	67	2469
14	2416	41	2443	68	2470
15	2417	42	2444	69	2471
16	2418	43	2445	70	2472
17	2419	44	2446	71	2473
18	2420	45	2447	72	2474
19	2421	46	2448	73	2475
20	2422	47	2449	74	2476
21	2423	48	2450	75	2477
22	2424	49	2451	76	2478
23	2425	50	2452	77	2479
24	2426	51	2453	78	2480
25	2427	52	2454		
26	2428	53	2455		

3.

Table for Filed Antenna

Ant	Brand	Model Name	Antenna Type	Connector	Gain (dBi)	NOTE
1	N/A	N/A	PCB Antenna	ipex connector	0	

DESCRIPTION OF TEST MODES

To investigate the maximum EMI emission characteristics generates from EUT, the test system was pre-scanning tested base on the consideration of following EUT operation mode or test configuration mode which possible have effect on EMI emission level. Each of these EUT operation mode(s) or test configuration mode(s) mentioned above was evaluated respectively.	
Pretest Mode	Description
Mode 1	CH00
Mode 2	CH39
Mode 3	CH78
Mode 4	Link BT
For Conducted Emission	
Final Test Mode	Description
Mode 4	Link BT
For Radiated Emission	
Final Test Mode	Description
Mode 1	CH00
Mode 2	CH39
Mode 3	CH78
Note:	
(1) The measurements are performed at the highest, middle, lowest available channels.	
(2) Measurements are performed according to the Public Notice-DA 00-705.	
(3) Test perform on all mode(BDR and EDR), only records worse cases in the test report.	

TABLE OF PARAMETERS OF TEXT SOFTWARE SETTING

During testing channel & power controlling software provided by the customer was used to control the operating channel as well as the output power level. The RF output power selection is for the setting of RF output power expected by the customer and is going to be fixed on the firmware of the final end product power parameters of FHSS			
Test software Version	Test program: Broadcom		
Frequency	2402 MHz	2441 MHz	2480 MHz
Parameters	DEF	DEF	DEF

BLOCK DIGRAM SHOWING THE CONFIGURATION OF SYSTEM TESTED

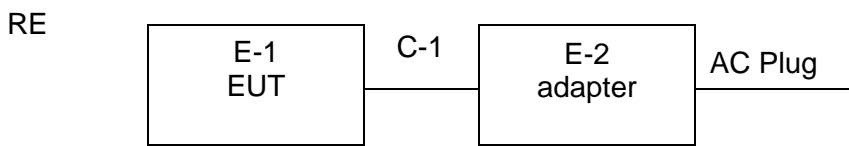

RF conducted measurement

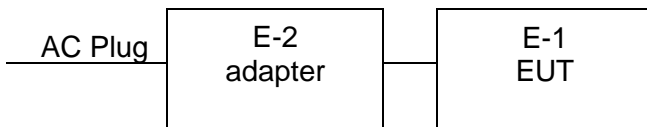

CE

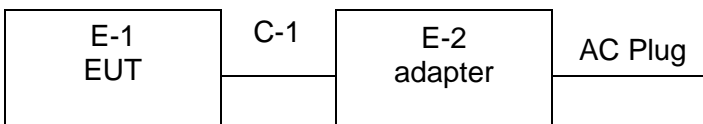

DESCRIPTION OF SUPPORT UNITS(CONDUCTED MODE)

The EUT has been tested as an independent unit together with other necessary accessories or support units. The following support units or accessories were used to form a representative test configuration during the tests.

Item	Equipment	Brand	Model/Type No.	Series No.	Note
E-1	WiFi connected digital frame for streaming art	MEURAL	MEU020DC27	N/A	EUT
E-2	adapter	N/A	FJ-SW1204000U	N/A	N/A

Item	Shielded Type	Ferrite Core	Length	Note
C-1	NO	NO	1.5cm	Adapter DC Cable

Note:	
(1)	The support equipment was authorized by Declaration of Confirmation.
(2)	For detachable type I/O cable should be specified the length in cm in 『 Length 』 column.
(3)	“YES” is means “shielded” “with core”; “NO” is means “unshielded” “without core”.

Equipments List for All Test Items

No	Test Equipment	Manufacturer	Model No	Serial No	Cal. Date	Cal. Due Date
1	L.I.S.N.#1	Kyoritsu	KNW-242	8-837-4	2017.06.29	2018.06.29
2	L.I.S.N.#2	Kyoritsu	KNW-407	8-1789-4	2017.06.29	2018.06.29
3	EMI Receiver	R&S	ESCI	100124	2017.06.29	2018.06.29
4	Coaxial Switch	Anritsu	MP59B	620026441 7	2017.06.29	2018.06.29
5	Cable 0.09-30MHz	N/A	AIT005	C001	2017.06.29	2018.06.29
6	SIGNAL ANALYZER	R&S	FSV40	101470	2017.06.29	2018.06.29
7	EMI Measuring Receiver	R&S	ESR	101660	2017.06.29	2018.06.29
8	Low Noise Pre Amplifier	Tsj	MLA-10K01-B01-27	1205323	2017.06.29	2018.06.29
9	Low Noise Pre Amplifier	Tsj	MLA-0120-A02-34	2648A04738	2017.06.29	2018.06.29
10	TRILOG Super Broadband test Antenna	SCHWARZBECK	VULB9160	9160-3206	2017.06.29	2018.06.29
11	Broadband Horn Antenna	SCHWARZBECK	BBHA9120D	452	2017.06.29	2018.06.29
12	SHF-EHF Horn	SCHWARZBECK	BBHA9170	BBHA917036 7	2017.06.29	2018.06.29
13	Loop Antenna	ETS	6512	00165355	2017.06.29	2018.06.29
14	Radiated Cable 1# (30MHz-1GHz)	FUJIKURA	5D-2W	01	2017.06.29	2018.06.29
15	Radiated Cable 2# (1GHz -40GHz)	FUJIKURA	10D2W	02	2017.06.29	2018.06.29
16	Conducted Cable 1#(9KHz-30MHz)	FUJIKURA	1D-2W	01	2017.06.29	2018.06.29
17	Power Meter	Anritsu	ML2495A	N/A	2017.06.29	2018.06.29



18	Power sensor	Anritsu	MA2411B	N/A	2017.06.29	2018.06.29
----	--------------	---------	---------	-----	------------	------------

Note: N/A

3. EMC EMISSION TEST

CONDUCTED EMISSION MEASUREMENT

POWER LINE CONDUCTED EMISSION Limits (Frequency Range 150KHz-30MHz)

FREQUENCY (MHz)	Class A (dBuV)		Class B (dBuV)		Standard
	Quasi-peak	Average	Quasi-peak	Average	
0.15 -0.5	79.00	66.00	66 - 56 *	56 - 46 *	CISPR
0.50 -5.0	73.00	60.00	56.00	46.00	CISPR
5.0 -30.0	73.00	60.00	60.00	50.00	CISPR

0.15 -0.5	79.00	66.00	66 - 56 *	56 - 46 *	FCC
0.50 -5.0	73.00	60.00	56.00	46.00	FCC
5.0 -30.0	73.00	60.00	60.00	50.00	FCC

Note:

- (1) The tighter limit applies at the band edges.
- (2) The limit of " * " marked band means the limitation decreases linearly with the logarithm of the frequency in the range.

The following table is the setting of the receiver

Receiver Parameters	Setting
ZCTenuation	10 dB
Start Frequency	0.15 MHz
Stop Frequency	30 MHz
IF Bandwidth	9 kHz

3.1.2 TEST PROCEDURE

- a. The EUT was placed 0.8 meters from the horizontal ground plane with EUT being connected to the power mains through a line impedance stabilization network (LISN). All other support equipments powered from additional LISN(s). The LISN provide 50 Ohm/ 50uH of coupling impedance for the measuring instrument.
- b. Interconnecting cables that hang closer than 40 cm to the ground plane shall be folded back and forth in the center forming a bundle 30 to 40 cm long.
- c. I/O cables that are not connected to a peripheral shall be bundled in the center. The end of the cable may be terminated, if required, using the correct terminating impedance. The overall length shall not exceed 1 m.
- d. LISN at least 80 cm from nearest part of EUT chassis.
- e. For the actual test configuration, please refer to the related Item –EUT Test Photos.

3.1.3 DEVIATION FROM TEST STANDARD

No deviation

3.1.4 TEST SETUP

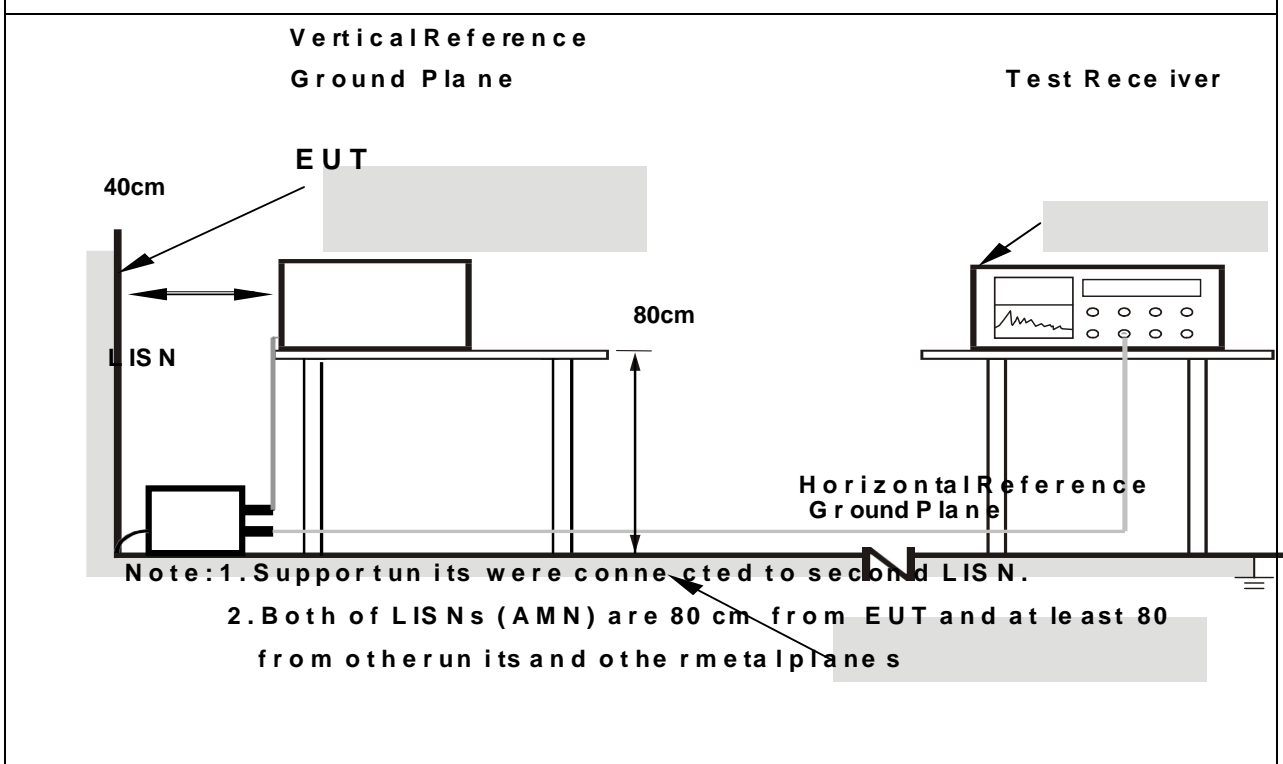

3.1.5 EUT OPERATING CONDITIONS

The EUT was configured for testing in a typical fashion (as a customer would normally use it). The EUT has been programmed to continuously transmit during test. This operating condition was tested and used to collect the included data.

3.1.6 TEST RESULTS

EUT:	WiFi connected digital frame for streaming art	Model Name :	MEU020DC27
Temperature:	26 °C	Relative Humidity:	54%
Pressure:	1010hPa	Phase :	Line
Test Voltage :	DC 12V from adapter, AC 120V/60Hz for adapter	Test Mode:	4

Frequency (MHz)	Meter Reading (dBμV)	Factor(dB)	Emission Level (dBμV)	Limits (dBμV)	Margin (dB)	Detector
0.1620	44.03	11.68	55.71	65.36	-9.65	QP
0.1620	33.53	11.68	45.21	55.36	-10.15	Average
0.5220	27.11	10.01	37.12	56.00	-18.88	QP
0.5220	20.32	10.01	30.33	46.00	-15.67	Average
24.3220	37.90	11.21	49.11	60.00	-10.89	QP
24.3220	30.05	11.21	41.26	50.00	-8.74	Average

Remark: Factor = Absorbing clamp Factor + Cable Loss.

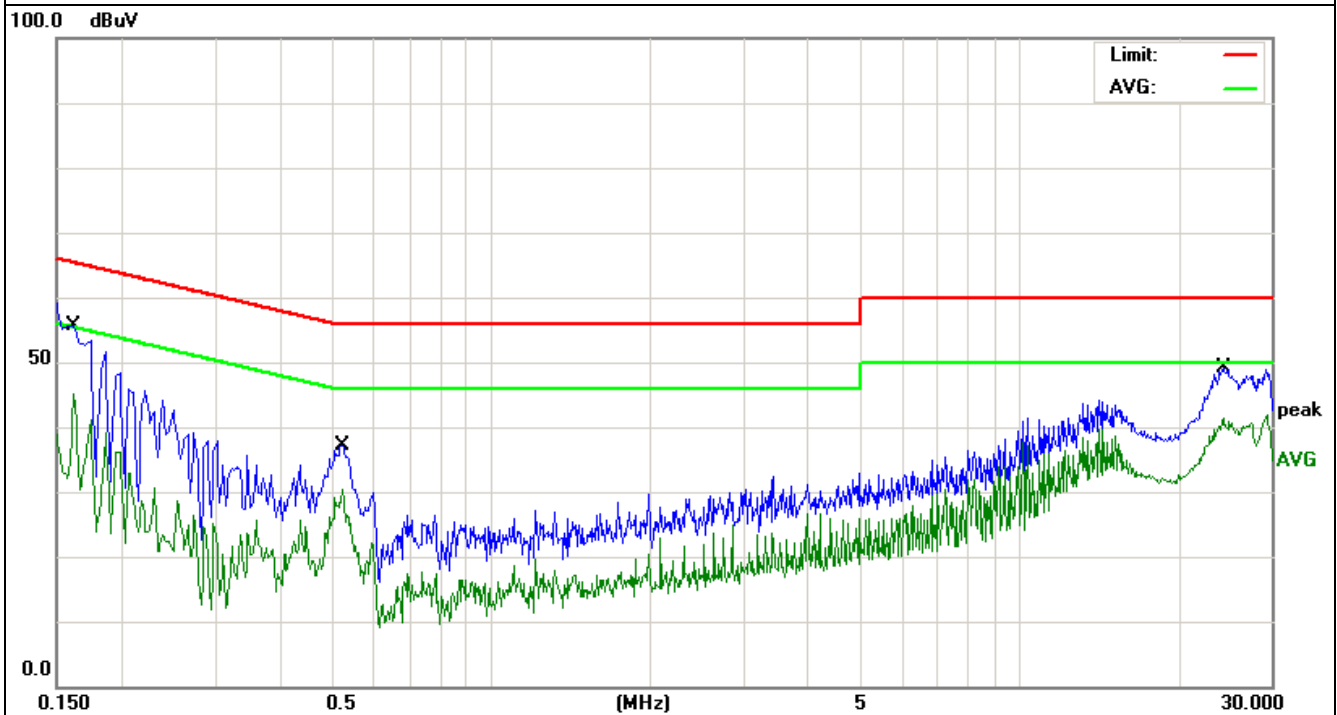

EUT:	WiFi connected digital frame for streaming art	Model Name :	MEU020DC27
Temperature:	26 °C	Relative Humidity:	54%
Pressure:	1010hPa	Phase :	Neutral
Test Voltage :	DC 12V from adapter, AC 120V/60Hz for adapter	Test Mode:	4

Frequency (MHz)	Meter Reading (dBμV)	Factor(dB)	Emission Level (dBμV)	Limits (dBμV)	Margin (dB)	Detector
0.1660	42.09	11.61	53.70	65.15	-11.45	QP
0.1740	31.86	11.48	43.34	54.76	-11.42	Average
0.5060	17.58	10.01	27.59	46.00	-18.41	QP
0.5260	24.71	10.01	34.72	56.00	-21.28	Average
24.2780	37.70	11.21	48.91	60.00	-11.09	QP
24.7180	30.52	11.23	41.75	50.00	-8.25	Average

Remark: Factor = Absorbing clamp Factor + Cable Loss.

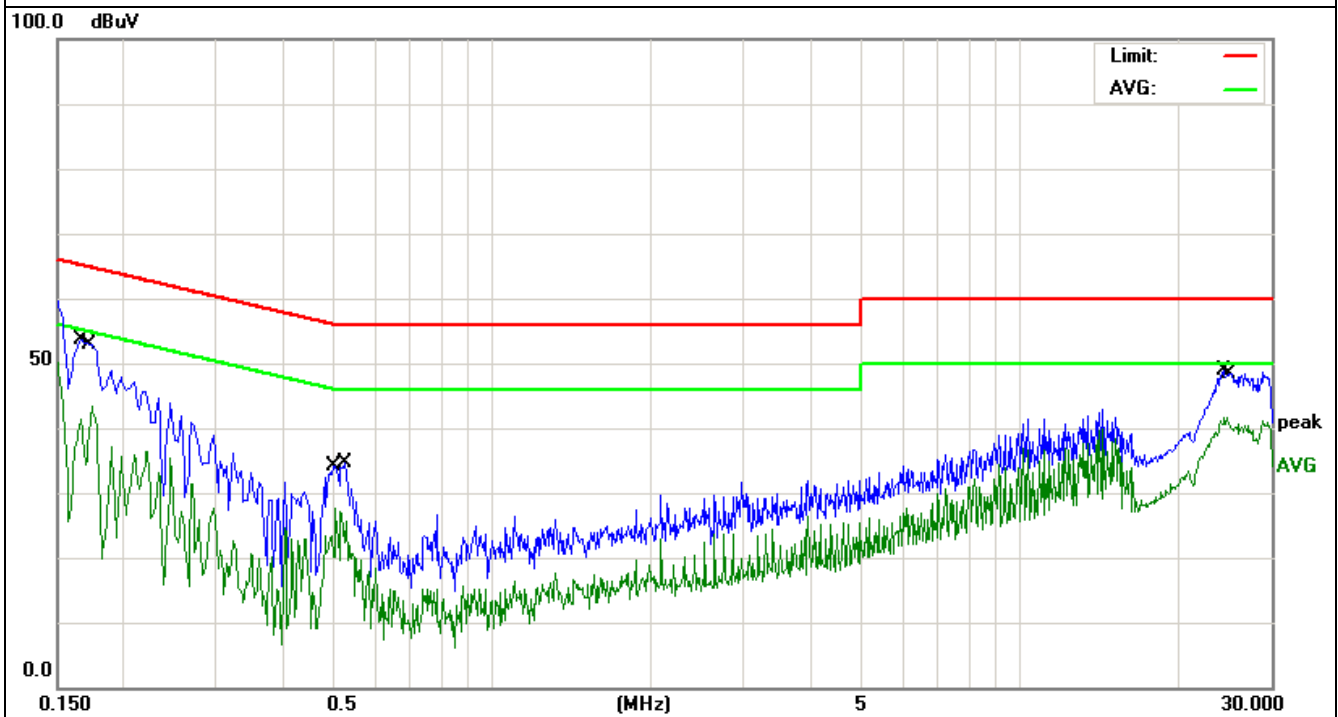

RADIATED EMISSION MEASUREMENT

3.2.1 RADIATED EMISSION LIMITS (Frequency Range 9kHz-1000MHz)		
20dBc in any 100 kHz bandwidth outside the operating frequency band. In case the emission fall within the restricted band specified on 15.205(a), then the 15.209(a) limit in the table below has to be followed.		
Frequencies (MHz)	Field Strength (micorvolts/meter)	Measurement Distance (meters)
0.009~0.490	2400/F(KHz)	300
0.490~1.705	24000/F(KHz)	30
1.705~30.0	30	30
30~88	100	3
88~216	150	3
216~960	200	3
Above 960	500	3

Notes:

- (1) The limit for radiated test was performed according to FCC PART 15C.
- (2) The tighter limit applies at the band edges.
- (3) Emission level (dBuV/m)=20log Emission level (uV/m).

Spectrum Parameter	Setting
ZCTenuation	Auto
Start Frequency	1000 MHz
Stop Frequency	10 th carrier harmonic
RB / VB (emission in restricted band)	1 MHz / 1 MHz for Peak, 1 MHz / 10Hz for Average

Receiver Parameter	Setting
ZCTenuation	Auto
Start ~ Stop Frequency	9kHz~150kHz / RB 200Hz for QP
Start ~ Stop Frequency	150kHz~30MHz / RB 9kHz for QP
Start ~ Stop Frequency	30MHz~1000MHz / RB 120kHz for QP

3.2.2 TEST PROCEDURE

a. The measuring distance of at 3 m shall be used for measurements at frequency up to 1GHz. For frequencies above 1GHz, any suitable measuring distance may be used.
b. The EUT was placed on the top of a rotating table 0.8 meters above the ground at a 3 meter open area test site. The table was rotated 360 degrees to determine the position of the highest radiation.
c. The height of the equipment or of the substitution antenna shall be 0.8 m; the height of the test antenna shall vary between 1 m to 4 m. Both horizontal and vertical polarizations of the antenna are set to make the measurement.
d. The initial step in collecting conducted emission data is a spectrum analyzer peak detector mode pre-scanning the measurement frequency range. Significant peaks are then marked and then Quasi Peak detector mode re-measured.
e. If the Peak Mode measured value compliance with and lower than Quasi Peak Mode Limit, the EUT shall be deemed to meet QP Limits and then no additional QP Mode measurement performed.
f. For the actual test configuration, please refer to the related Item –EUT Test Photos.
l. For the radiated emission test above 1GHz: Place the measurement antenna away from each area of the EUT determined to be a source of emissions at the specified measurement distance, while keeping the measurement antenna aimed at the source of emissions at each frequency of significant emissions, with polarization oriented for maximum response. The measurement antenna may have to be higher or lower than the EUT, depending on the radiation pattern of the emission and staying aimed at the emission source for receiving the maximum signal. The final measurement antenna elevation shall be that which maximizes the emissions. The measurement antenna elevation for maximum emissions shall be restricted to a range of heights of from 1 m to 4 m above the ground or reference ground plane.
Note:
Both horizontal and vertical antenna polarities were tested and performed pretest to three orthogonal axis. The worst case emissions were reported

3.2.3 DEVIATION FROM TEST STANDARD

No deviation

3.2.4 TEST SETUP

(A) Radiated Emission Test-Up Frequency Below 30MHz

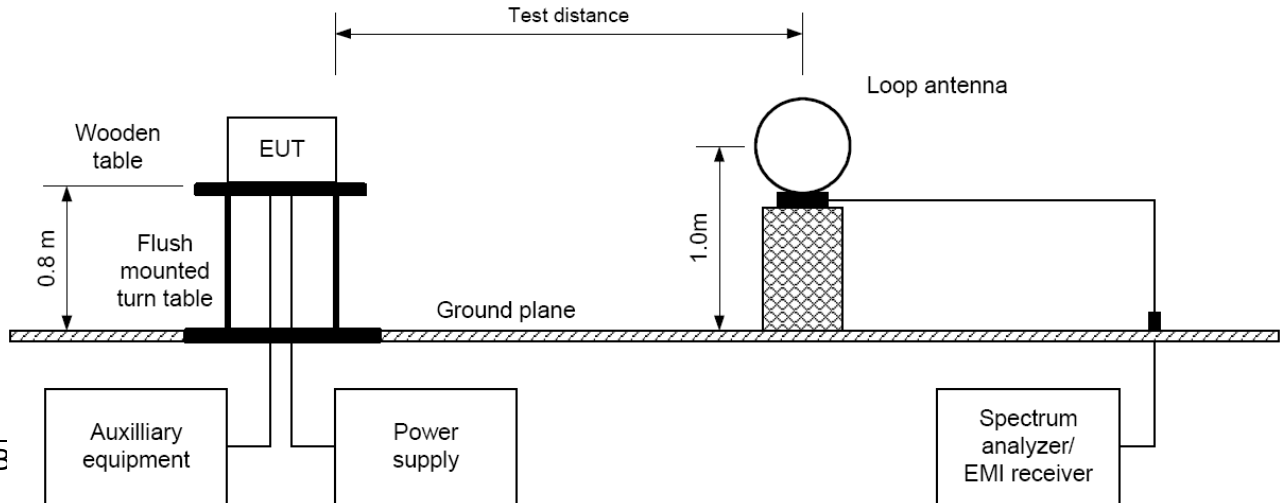

(B)

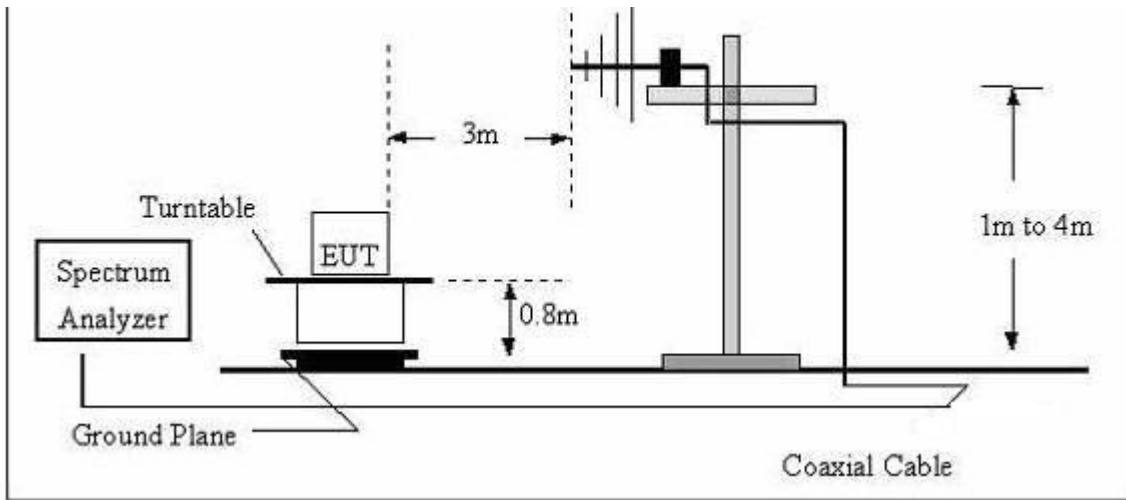

C) Radiated Emission Test-Up Frequency Above 1GHz

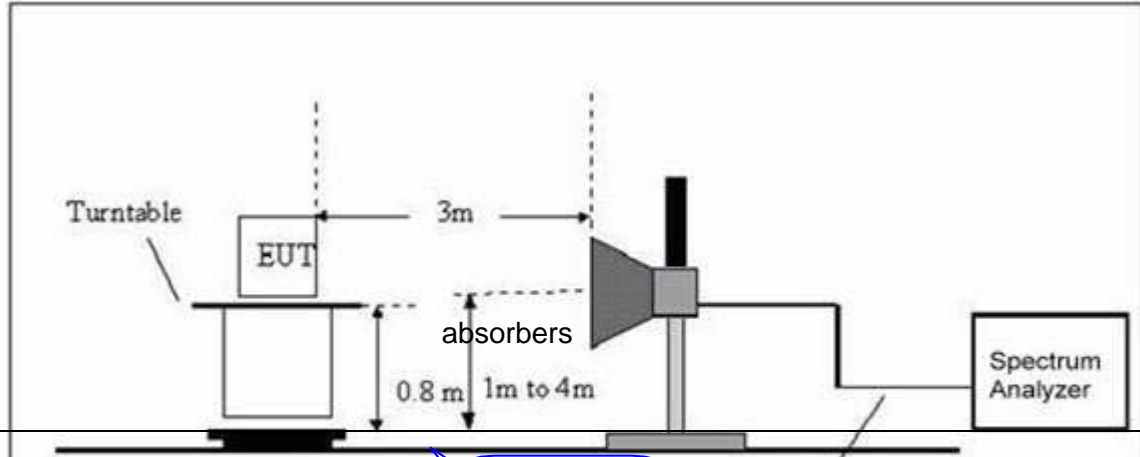

3.2.5 EUT OPERATING CONDITIONS

The EUT tested system was configured as the statements of 2.4 Unless otherwise a special operating condition is specified in the follows during the testing.

3.2.6 TEST RESULTS (BELOW 30 MHZ)

EUT:	WiFi connected digital frame for streaming art	Model Name :	MEU020DC27
Temperature:	20 °C	Relative Humidity:	48%
Pressure:	1010 hPa	Test Voltage :	DC 12V from adapter, AC 120V/60Hz for adapter
Test Mode :	TX	Polarization :	---

Freq.	Reading	Limit	Margin	State
(MHz)	(dBuV/m)	(dBuV/m)	(dB)	P/F
--	--	--	--	P
--	--	--	--	P

NOTE:

The amplitude of spurious emissions which are ZCTenuated by more than 20dB below the permissible value has no need to be reported.

Distance extrapolation factor = 20 log (specific distance/test distance)(dB);

Limit line = specific limits(dBuv) + distance extrapolation factor.

3.2.7 TEST RESULTS (BETWEEN 30M – 1000 MHZ)

EUT:	WiFi connected digital frame for streaming art	Model Name :	MEU020DC27
Temperature:	24 °C	Relative Humidity:	54%
Pressure:	1010hPa	Test Mode:	TX 2402
Test Voltage :	DC 12V from adapter,AC 120V/60Hz for adapter		

Polar (H/V)	Frequency	Meter Reading	Factor	Emission Level	Limits	Margin	Detector Type
	(MHz)	(dBuV)	(dB)	(dBuV/m)	(dBuV/m)	(dB)	
V	81.7832	54.92	-18.92	36.00	40.00	-4.00	QP
V	112.5243	53.15	-13.77	39.38	43.50	-4.12	QP
V	128.1128	54.21	-15.01	39.20	43.50	-4.30	QP
V	239.9874	54.94	-14.07	40.87	46.00	-5.13	QP
V	360.4476	44.65	-7.59	37.06	46.00	-8.94	QP
V	601.4265	39.40	-0.89	38.51	46.00	-7.49	QP
H	80.6441	55.47	-18.67	36.80	40.00	-3.20	QP
H	169.0054	53.37	-13.62	39.75	43.50	-3.75	QP
H	208.5801	56.19	-16.72	39.47	43.50	-4.03	QP
H	273.2341	50.88	-12.16	38.72	46.00	-7.28	QP
H	366.8231	46.47	-7.57	38.90	46.00	-7.10	QP
H	541.3723	44.14	-4.14	40.00	46.00	-6.00	QP

Remark:

Absolute Level= ReadingLevel+ Factor, Margin= Absolute Level - Limit

Note:test perform on BDR/EDR mode,"BDR TX 2402" mode is the worst mode and has been reported.

3.2.8 TEST RESULTS (Above 1GHz~ 10th harmonic)

EUT:	WiFi connected digital frame for streaming art	Model Name :	MEU020DC27
Temperature:	24 °C	Relative Humidity:	48%
Pressure:	1010hPa	Test Mode:	TX
Test Voltage:	DC 12V from adapter,AC 120V/60Hz for adapter		

Low Channel (2402 MHz)-Above 1G							
Frequency (MHz)	Meter Reading (dBuV)	Factor (dB)	Emission Level (dBuV/m)	Limits (dBuV/m)	Margin (dB)	Detect or Type	Polar (H/V)
4804.000	48.89	5.06	53.95	74.00	-20.05	Pk	Vertical
4804.000	34.54	5.06	39.60	54.00	-14.40	Av	Vertical
7206.000	45.75	7.03	52.78	74.00	-21.22	Pk	Vertical
7206.000	32.62	7.03	39.65	54.00	-14.35	Av	Vertical
4804.000	49.23	5.06	54.29	74.00	-19.71	Pk	Horizontal
4804.000	35.48	5.06	40.54	54.00	-13.46	Av	Horizontal
7206.000	44.69	7.03	51.72	74.00	-22.28	Pk	Horizontal
7206.000	31.53	7.03	38.56	54.00	-15.44	Av	Horizontal
Mid Channel (2441 MHz)-Above 1G							
4882.000	48.59	5.14	53.73	74.00	-20.27	Pk	Vertical
4882.000	35.47	5.14	40.61	54.00	-13.39	Av	Vertical
7323.000	44.35	7.55	51.90	74.00	-22.10	Pk	Vertical
7323.000	31.85	7.55	39.40	54.00	-14.60	Av	Vertical
4882.000	49.62	5.14	54.76	74.00	-19.24	Pk	Horizontal
4882.000	35.97	5.14	41.11	54.00	-12.89	Av	Horizontal
7323.000	44.78	7.55	52.33	74.00	-21.67	Pk	Horizontal
7323.000	32.85	7.55	40.40	54.00	-13.60	Av	Horizontal
High Channel (2480MHz)- Above 1G							
4960.000	49.83	5.22	55.05	74.00	-18.95	Pk	Vertical
4960.000	36.11	5.22	41.33	54.00	-12.67	Av	Vertical
7440.000	43.53	8.06	51.59	74.00	-22.41	Pk	Vertical
7440.000	31.67	8.06	39.73	54.00	-14.27	Av	Vertical
4960.000	48.77	5.22	53.99	74.00	-20.01	Pk	Horizontal
4960.000	35.09	5.22	40.31	54.00	-13.69	Av	Horizontal
7440.000	43.35	8.06	51.41	74.00	-22.59	Pk	Horizontal
7440.000	30.82	8.06	38.88	54.00	-15.12	Av	Horizontal

Note:test perform on BDR/EDR mode,"BDR" mode is the worst mode and has been reported.

Conducted Spurious Emissions at Antenna Port
(there are 150001 points are used for each measurement plot)

CH00-1Mbps

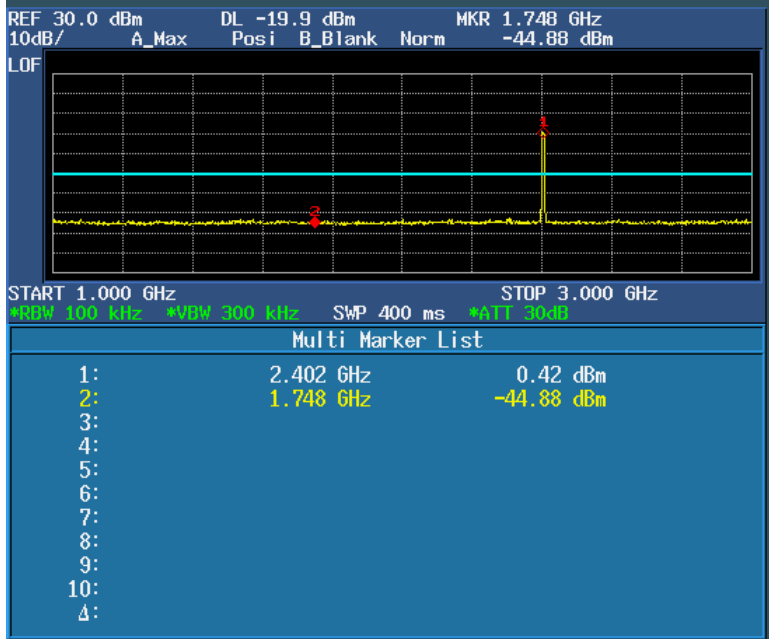
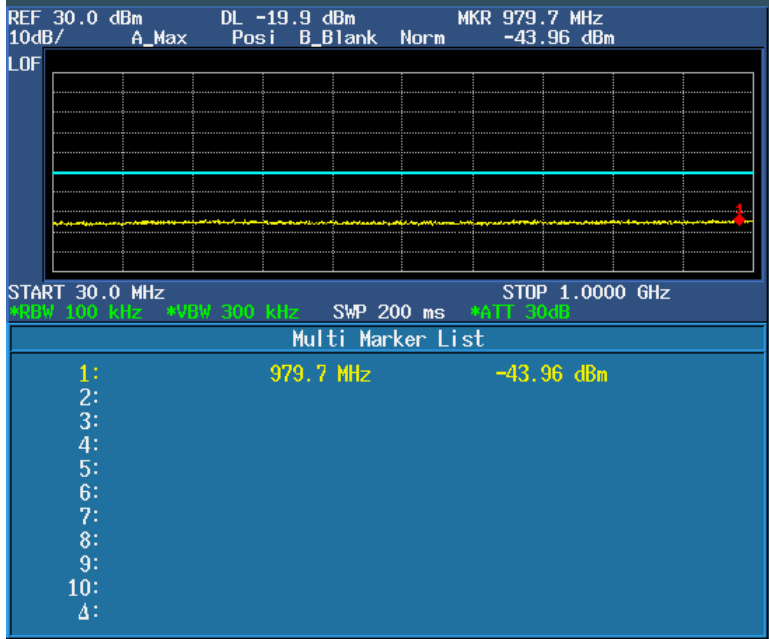

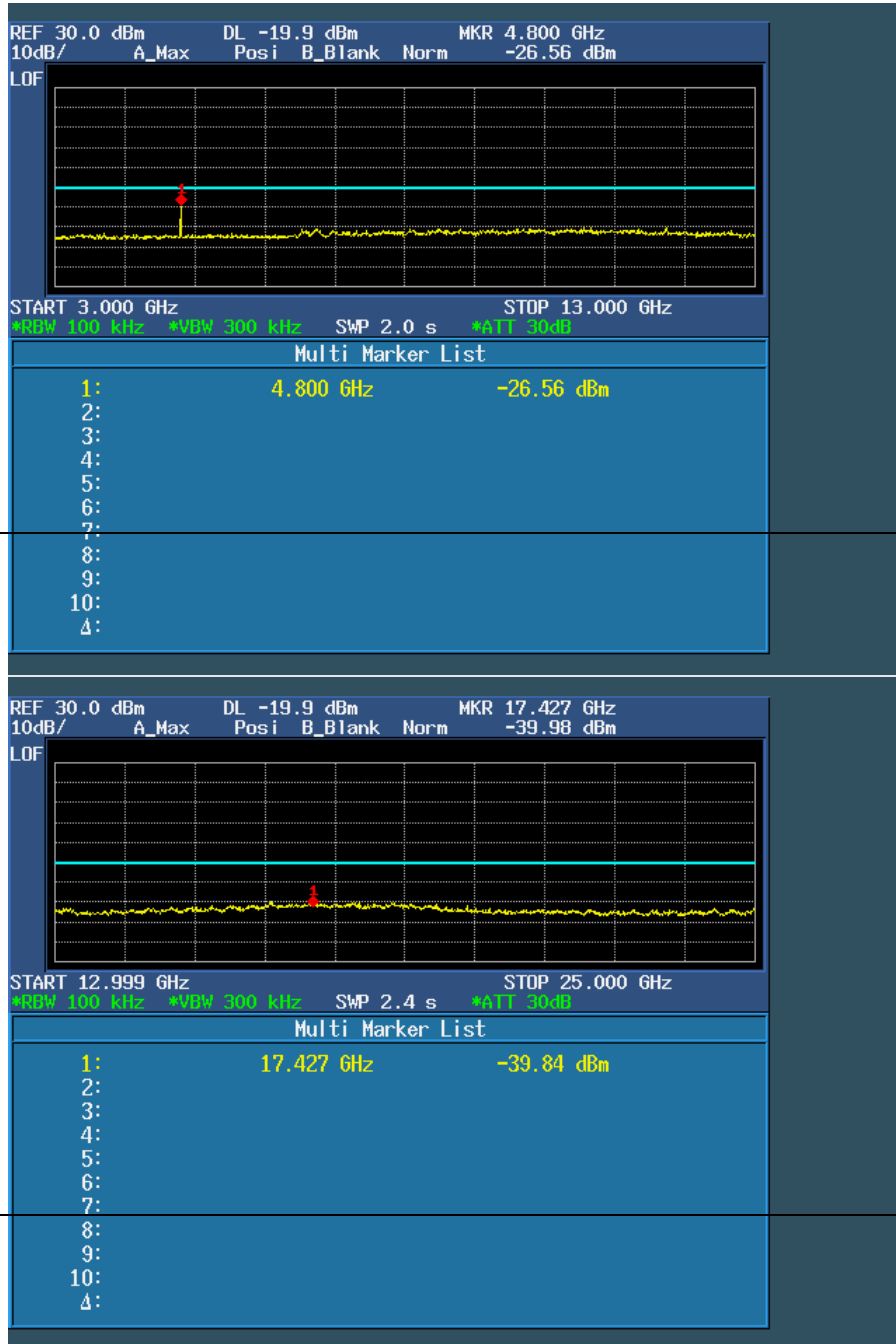

CH39-1Mbps

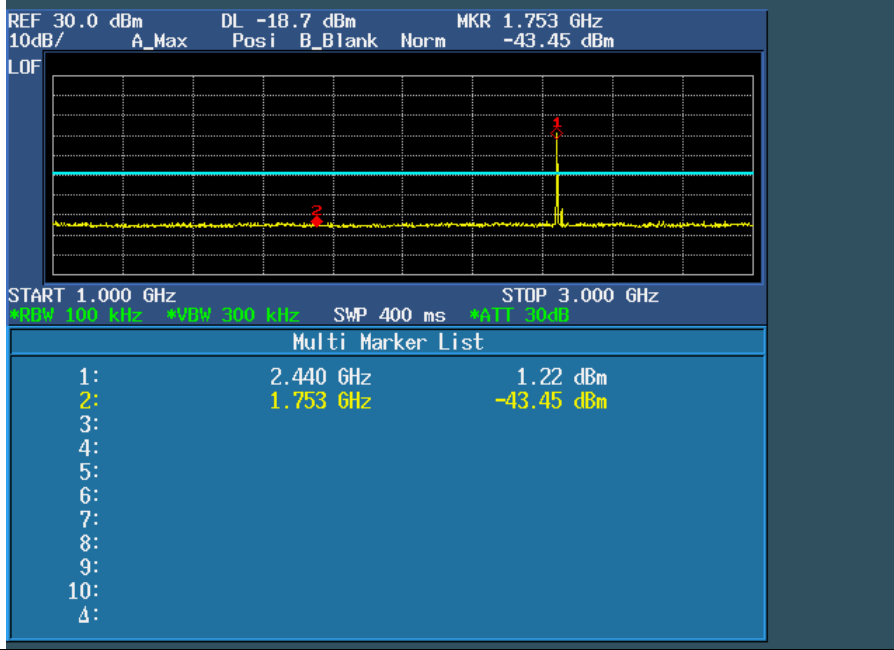
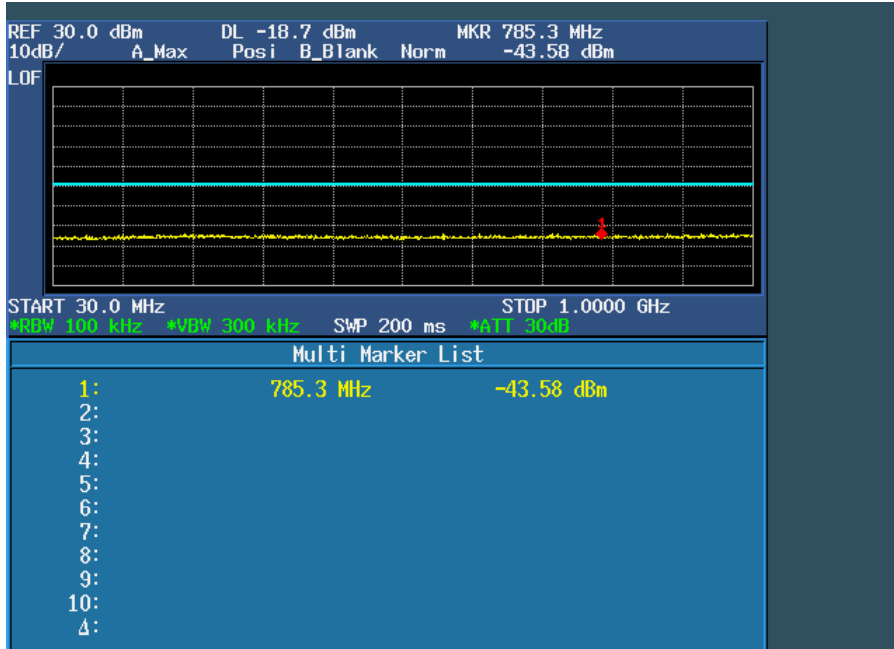

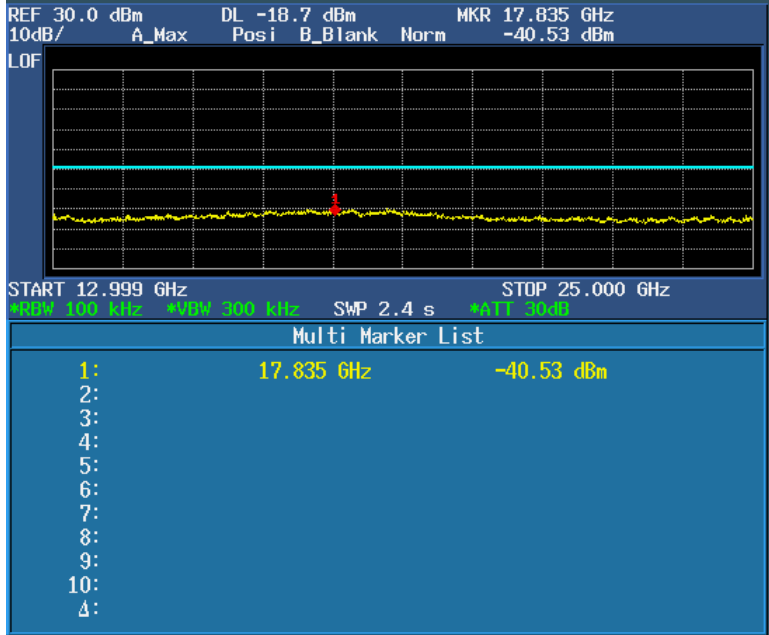
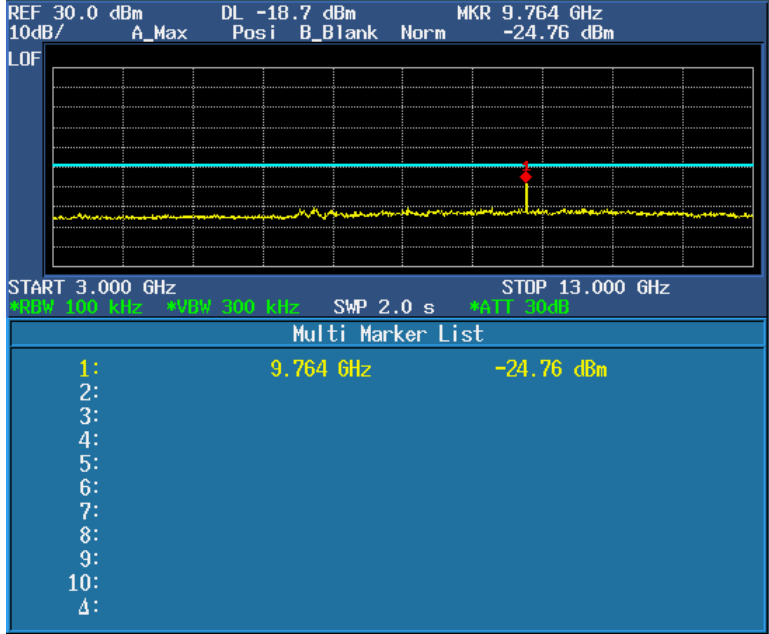

CH78-1Mbps

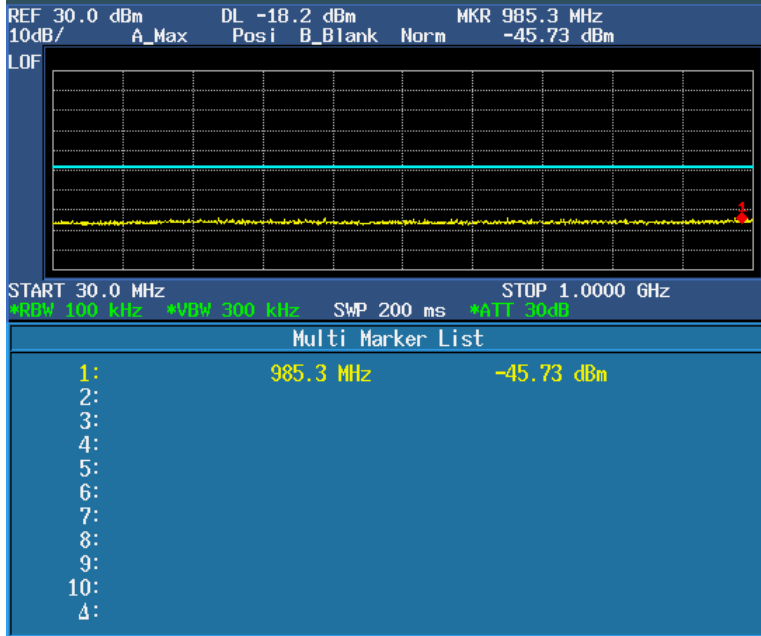

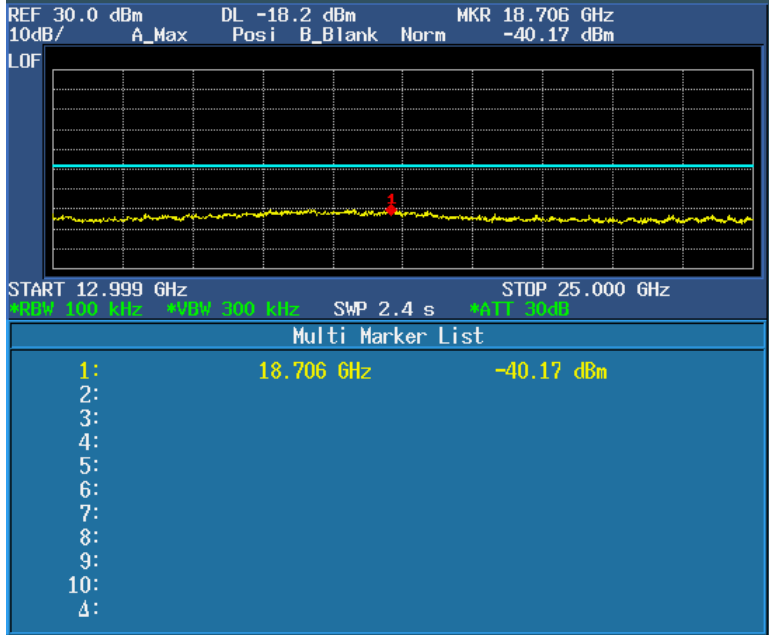
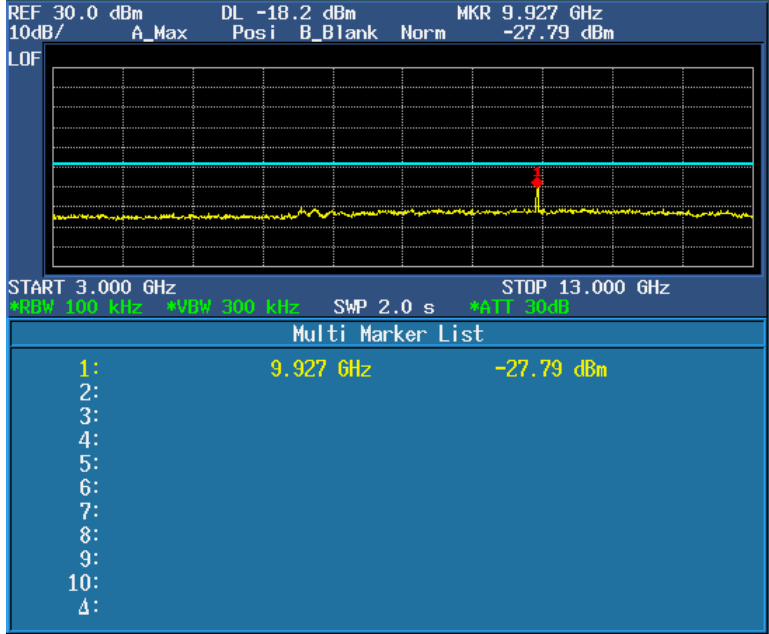

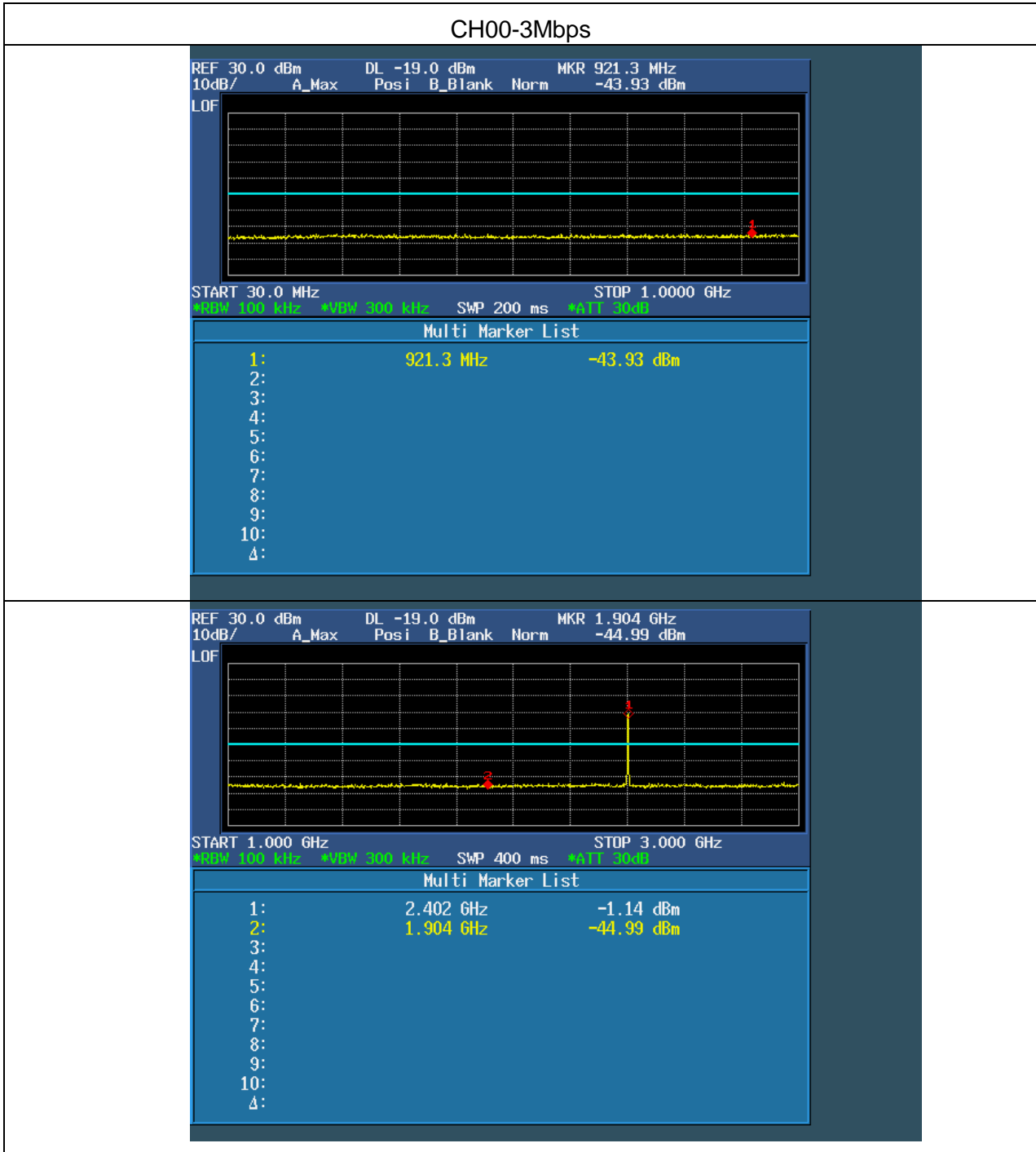

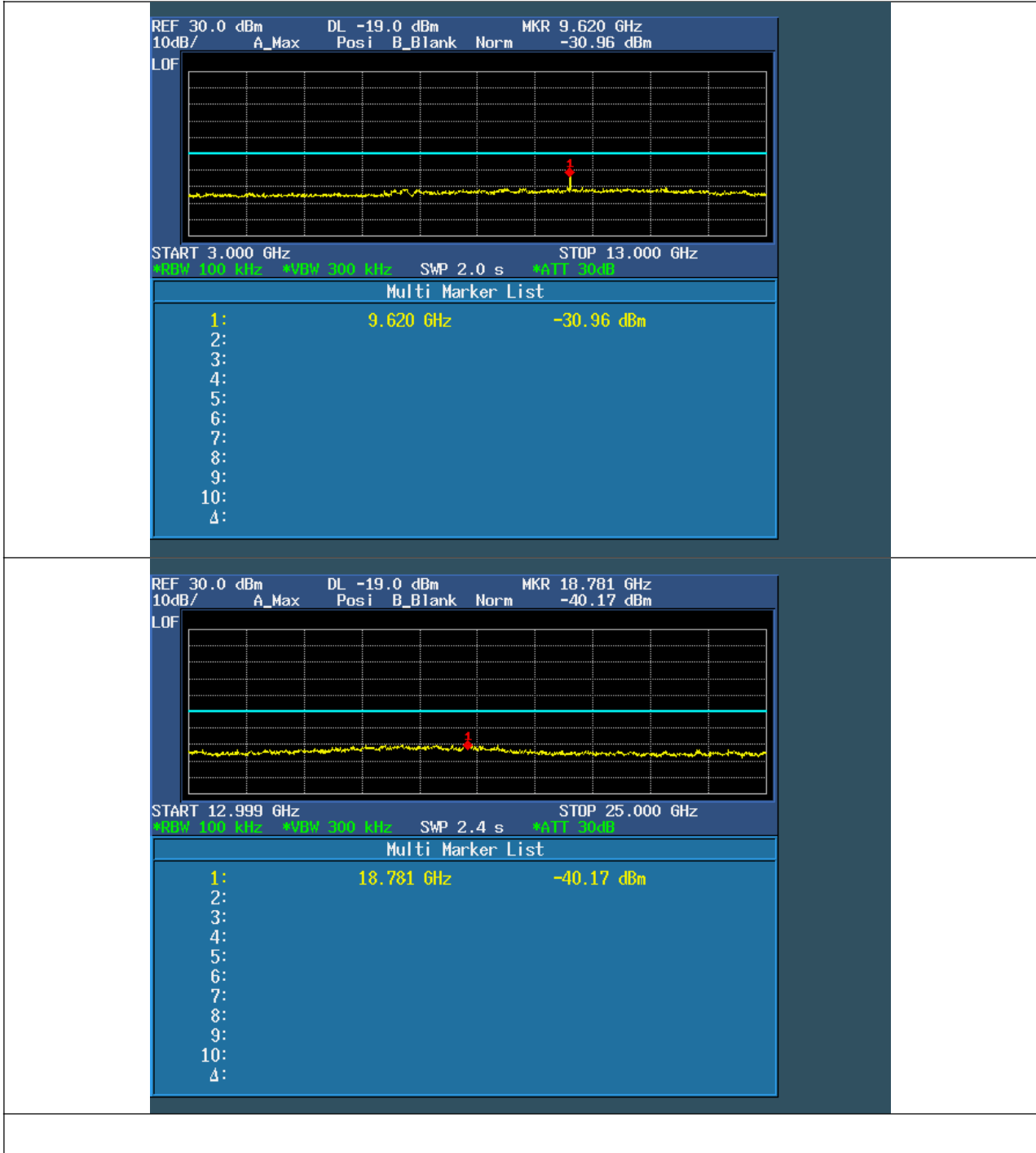

CH39-3Mbps

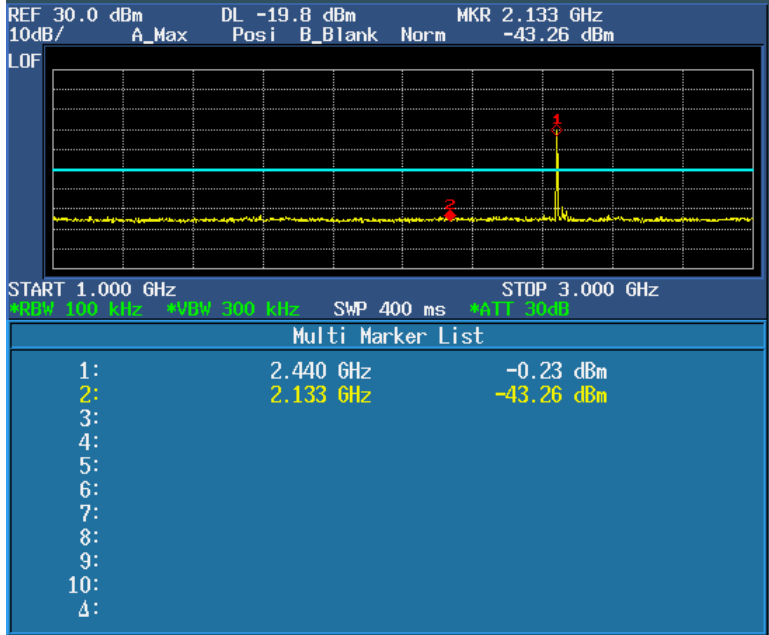
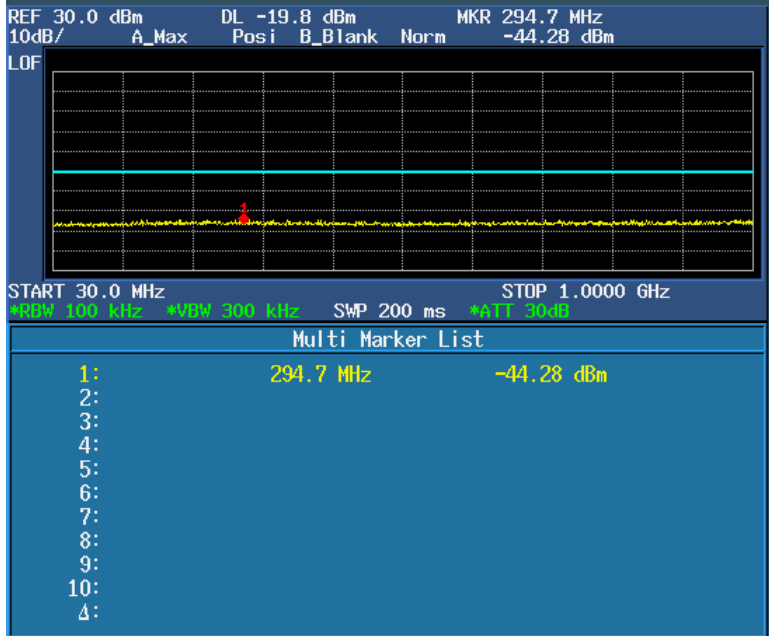

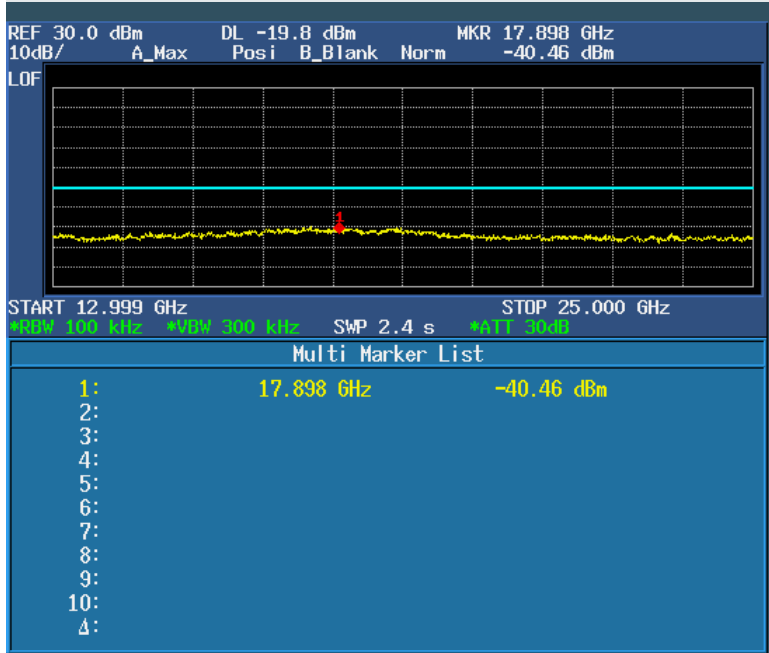
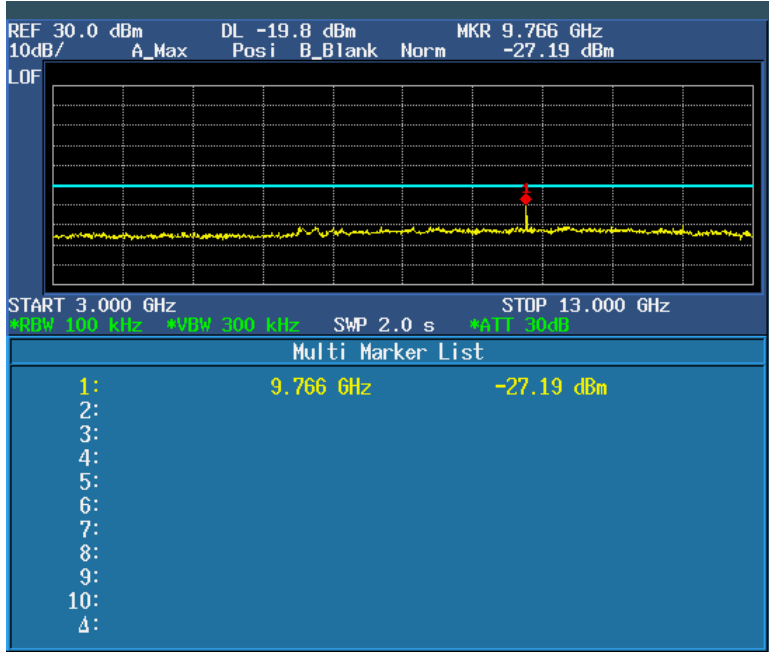

CH78-3Mbps

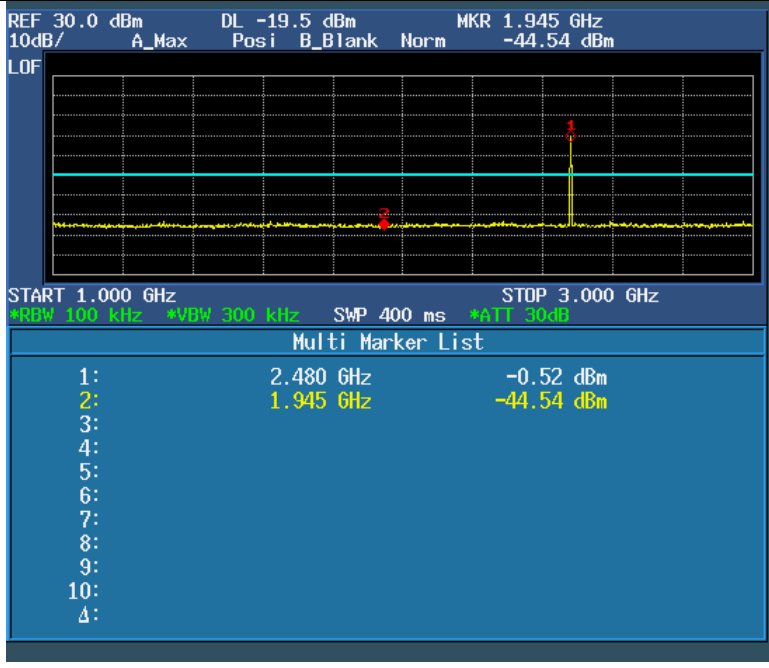
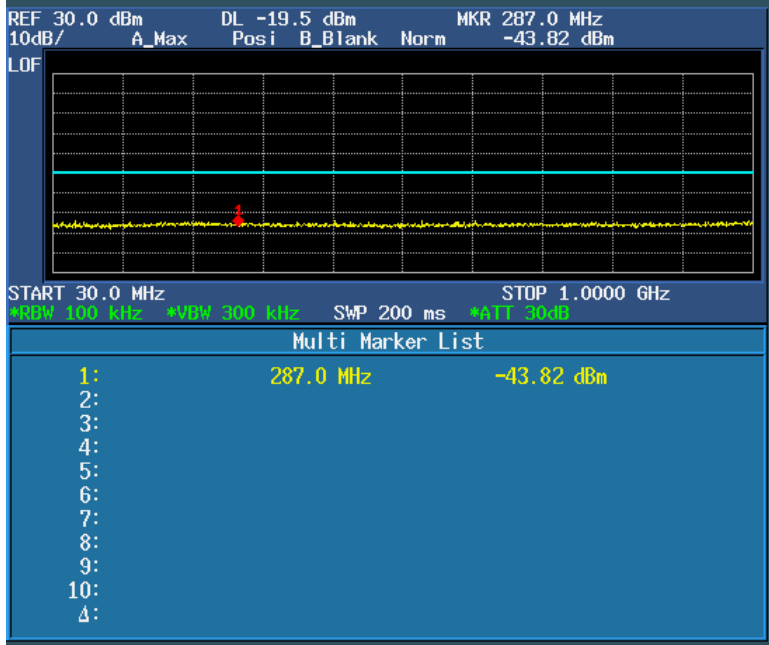

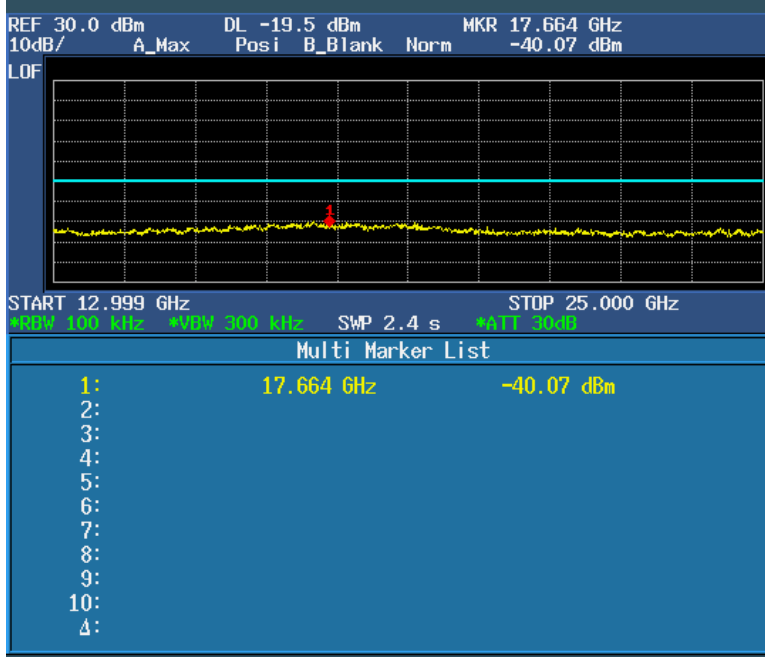
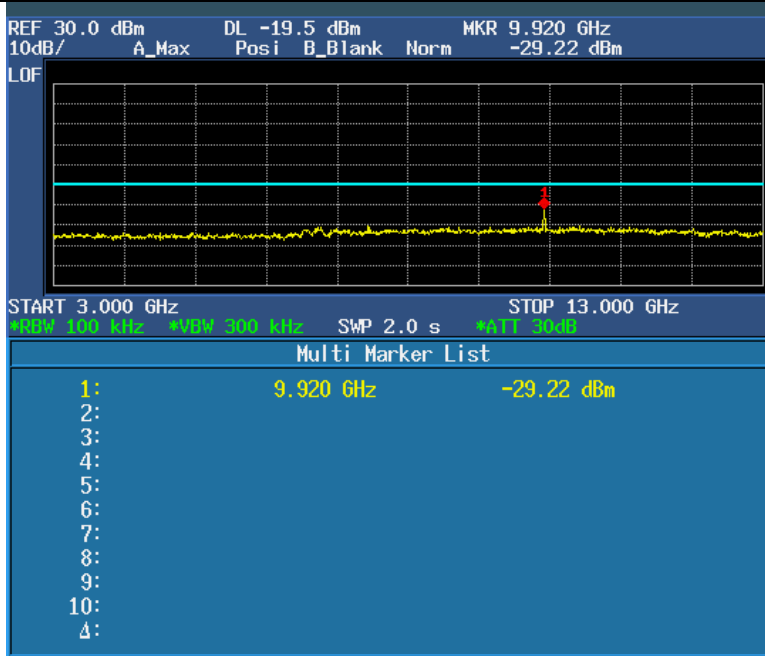

Note:test perform on BDR/EDR mode, the worst mode has been reported.

4. NUMBER OF HOPPING CHANNEL

APPLIED PROCEDURES / LIMIT

FCC Part15 (15.247) , Subpart C				
Section	Test Item	Limit	Frequency Range (MHz)	Result
15.247 (a)(1)(iii)	Number of Hopping Channel	≥15	2400-2483.5	PASS

Spectrum Parameters	Setting
ZCTenuation	Auto
Span Frequency	= the frequency band of operation
RB	≥ 1% of the span
VB	VBW ≥ RBW
Detector	Peak
Trace	Max Hold
Sweep Time	Auto

TEST PROCEDURE

- a. The EUT was directly connected to the spectrum analyzer and antenna output port as show in the block diagram below,
- b. Spectrum Setting : RBW= 1MHz, VBW=1MHz, Sweep time = Auto.

DEVIATION FROM STANDARD

No deviation.

TEST SETUP

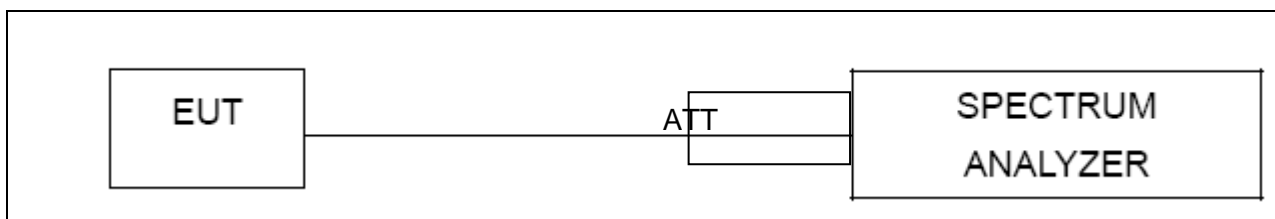

EUT OPERATION CONDITIONS

The EUT tested system was configured as the statements of 2.4 Unless otherwise a special operating condition is specified in the follows during the testing.

4.1.5 TEST RESULTS

EUT:	WiFi connected digital frame for streaming art	Model Name :	MEU020DC27
Temperature:	25 °C	Relative Humidity:	60%
Pressure:	1015 hPa	Test Voltage :	DC 12V from adapter,AC 120V/60Hz for adapter
Test Mode :	Hopping Mode-1Mbps		

Number of Hopping Channel	79
---------------------------	----

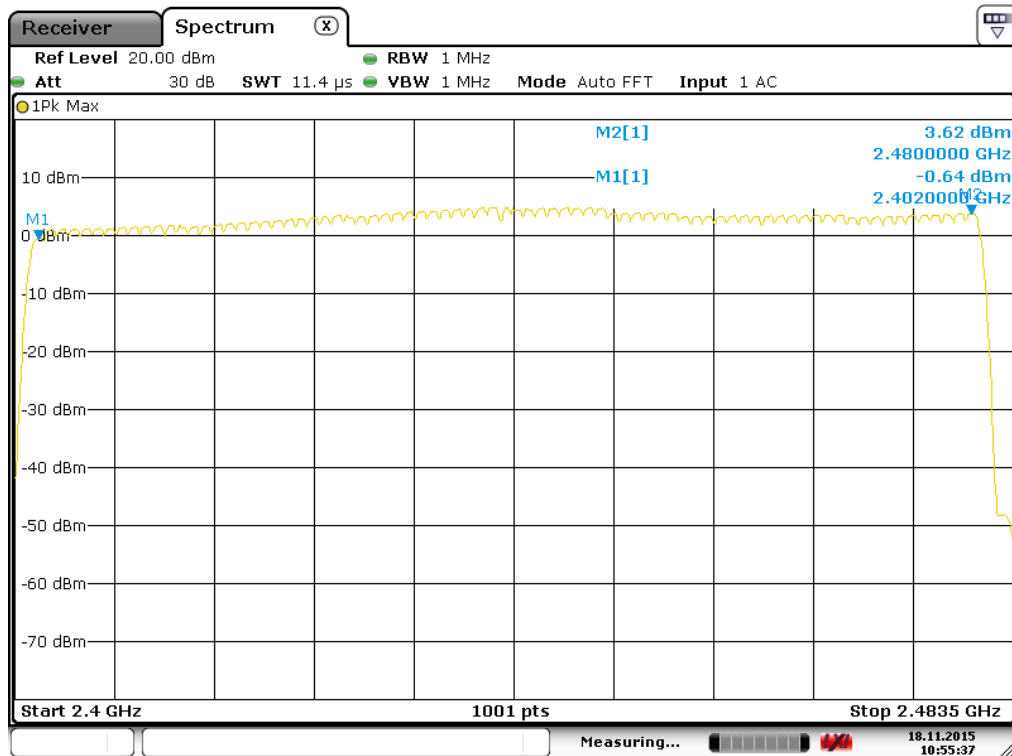

EUT:	WiFi connected digital frame for streaming art	Model Name :	MEU020DC27
Temperature:	25 °C	Relative Humidity:	60%
Pressure:	1015 hPa	Test Voltage :	DC 12V from adapter,AC 120V/60Hz for adapter
Test Mode :	Hopping Mode-3Mbps		

Number of Hopping Channel	79
---------------------------	----

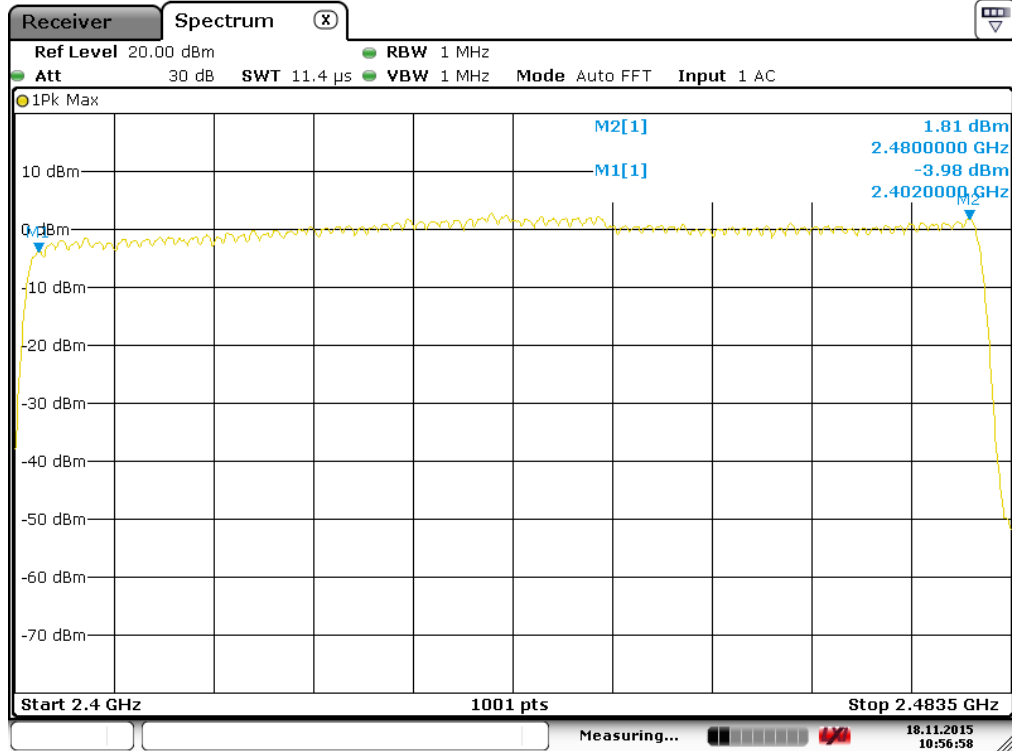

Shenzhen ZCT Technology Co., Ltd.

3/F., Building 5, Hongsheng Industrial Zone, Bao'an Road, Xixiang Street, Bao'an District, Shenzhen, Guangdong, China.

Tel: 400-805-1899 Fax: 86-755-23702323; <http://www.renzhengjiance.com>

5. AVERAGE TIME OF OCCUPANCY

APPLIED PROCEDURES / LIMIT

FCC Part15 (15.247) , Subpart C				
Section	Test Item	Limit	Frequency Range (MHz)	Result
15.247 (a)(1)(iii)	Average Time of Occupancy	0.4sec	2400-2483.5	PASS

5.1.1 TEST PROCEDURE

a.	The transmitter output (antenna port) was connected to the spectrum analyzer
b.	Set RBW of spectrum analyzer to 1MHz and VBW to 1MHz.
c.	Use a video trigger with the trigger level set to enable triggering only on full pulses.
d.	Sweep Time is more than once pulse time.
e.	Set the center frequency on any frequency would be measure and set the frequency span to zero span.
f.	Measure the maximum time duration of one single pulse.
h.	Measure the maximum time duration of one single pulse.

5.1.2 DEVIATION FROM STANDARD

No deviation.

5.1.3 TEST SETUP

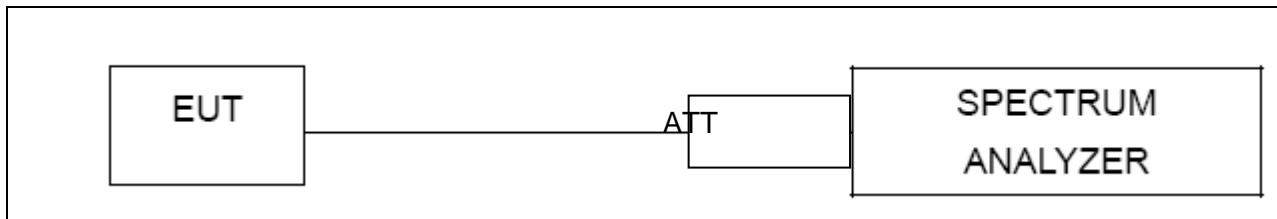

5.1.4 EUT OPERATION CONDITIONS

The EUT tested system was configured as the statements of 2.4 Unless otherwise a special operating condition is specified in the follows during the testing.

5.1.5 TEST RESULTS

EUT:	WiFi connected digital frame for streaming art	Model Name :	MEU020DC27
Temperature:	25 °C	Relative Humidity:	60%
Pressure:	1012 hPa	Test Voltage :	DC 12V from adapter,AC 120V/60Hz for adapter
Test Mode :	TX		

Data rate	Frequency	Plus Duration (ms)	Dwell Time (s)	Limits (s)
DH1	2441MHz	0.452	0.144	0.4
DH3	2441MHz	1.212	0.193	0.4
DH5	2441MHz	2.944	0.314	0.4

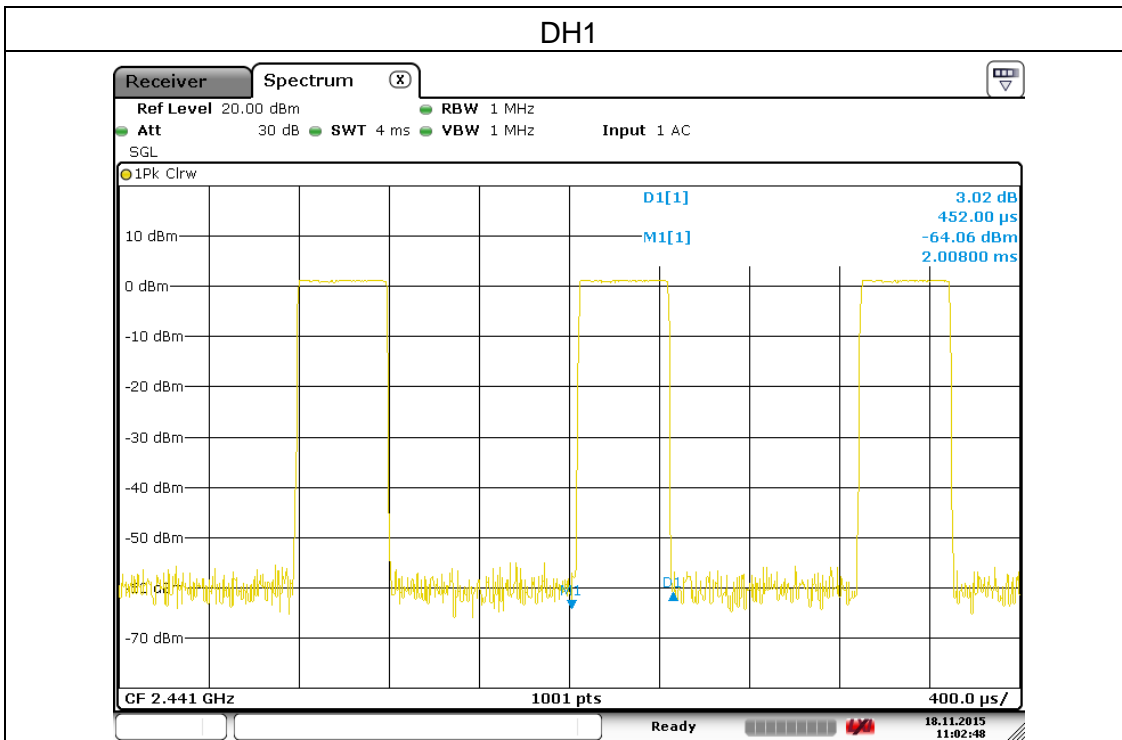

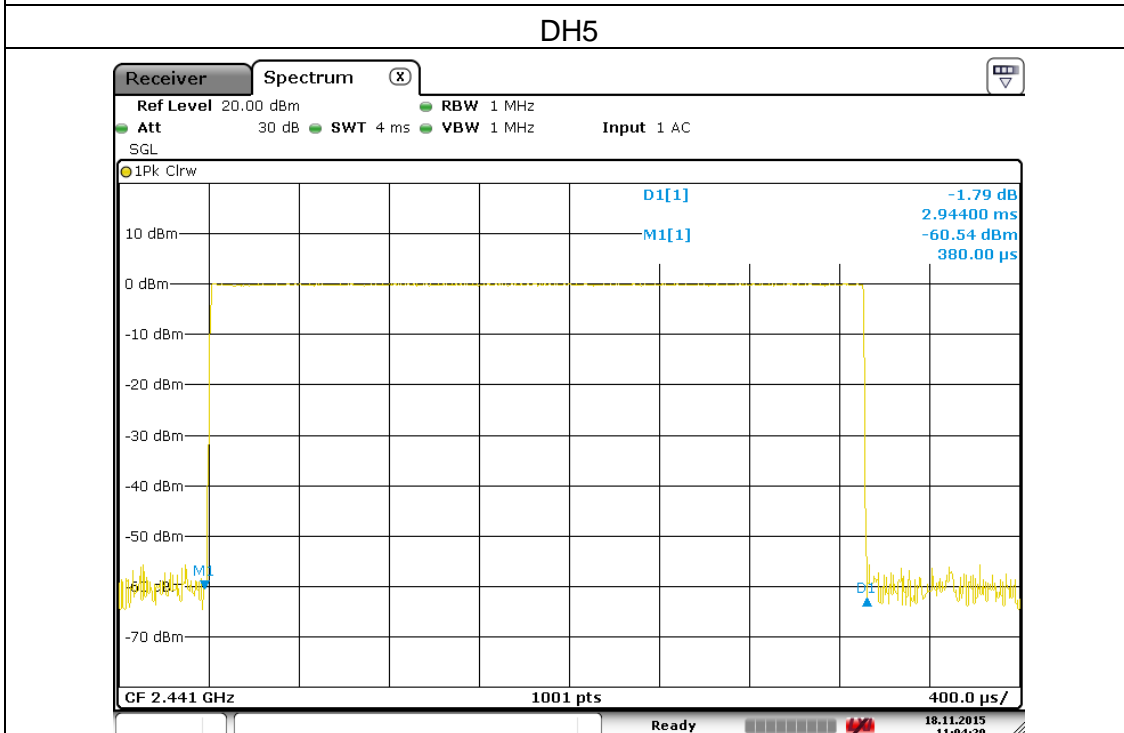
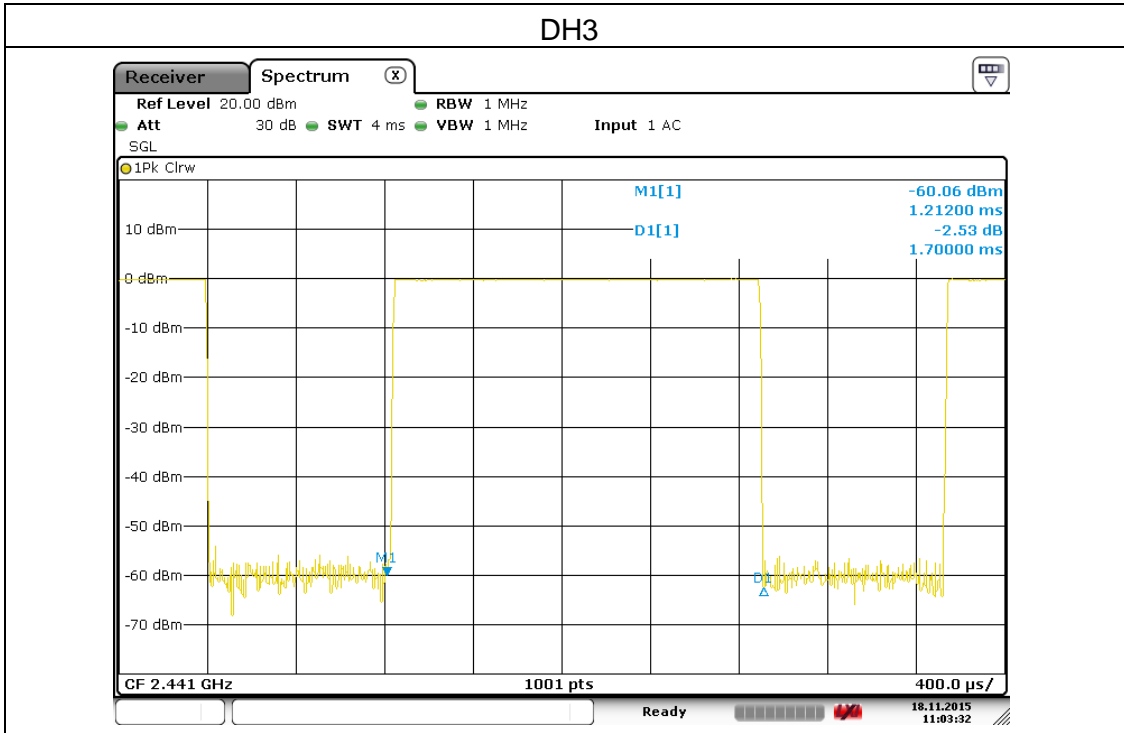

EUT:	WiFi connected digital frame for streaming art	Model Name :	MEU020DC27
Temperature:	25 °C	Relative Humidity:	60%
Pressure:	1012 hPa	Test Voltage :	DC 12V from adapter,AC 120V/60Hz for adapter
Test Mode :	TX		

Data rate	Frequency	Plus Duration (ms)	Dwell Time (s)	Limits (s)
3DH1	2441MHz	0.460	0.147	0.4
3DH3	2441MHz	1.704	0.272	0.4
3DH5	2441MHz	2.960	0.315	0.4

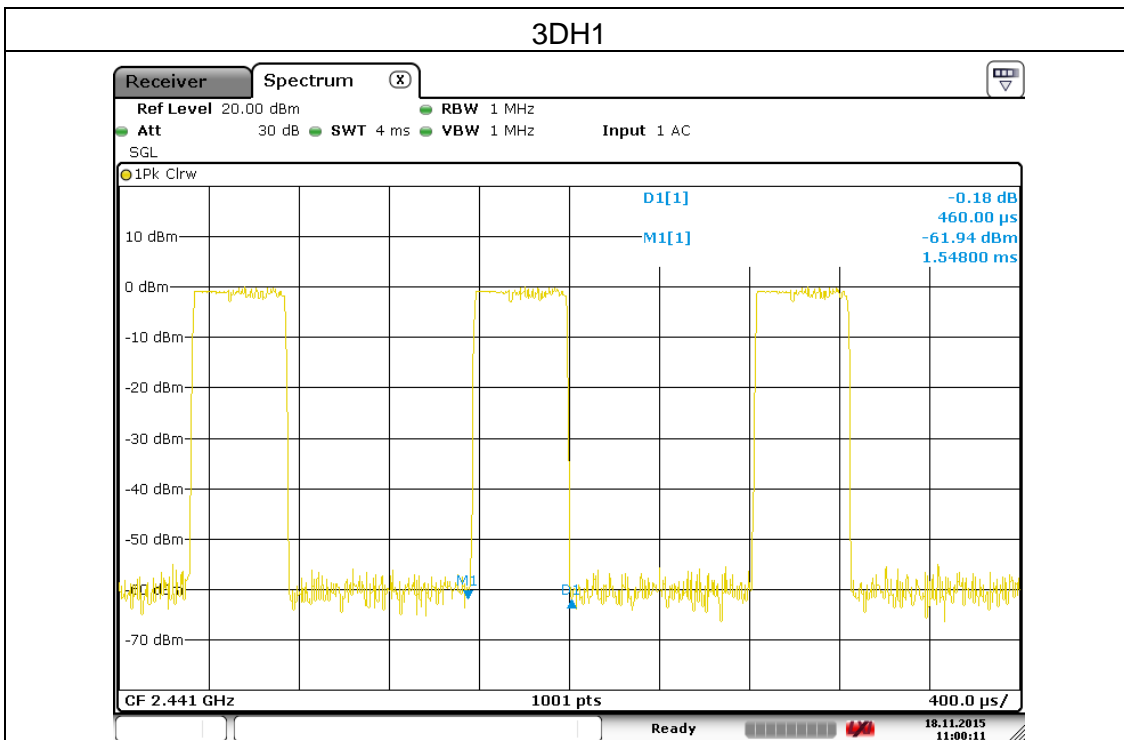

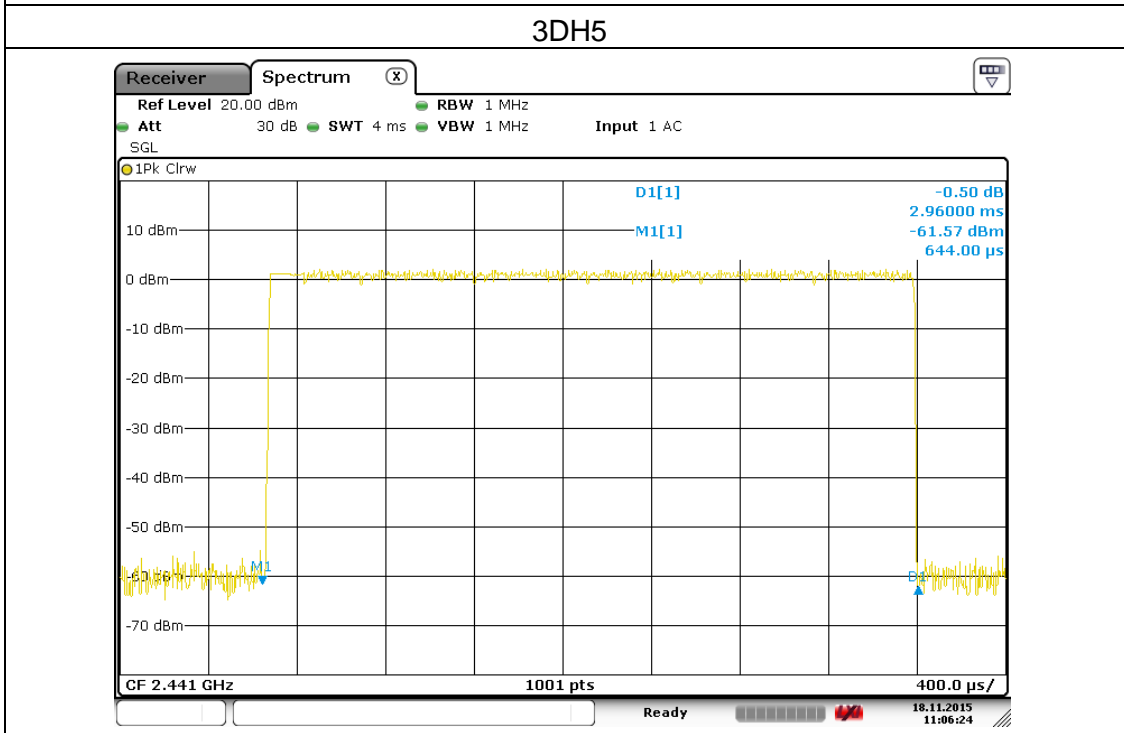
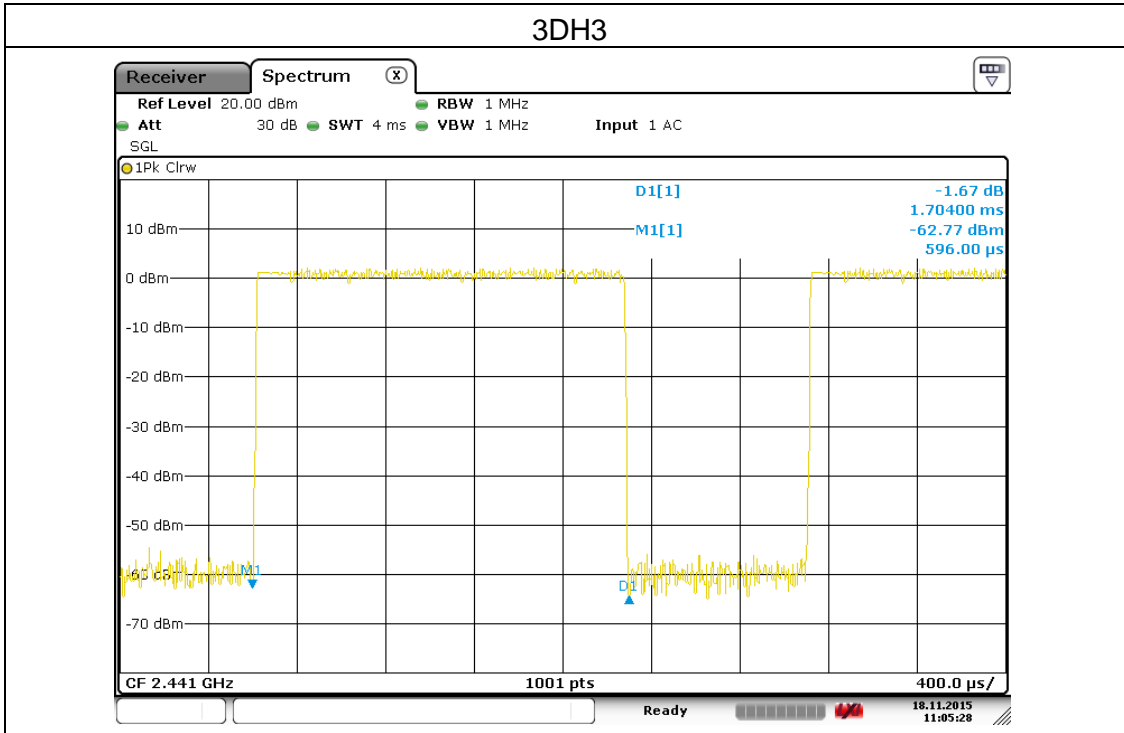

6. HOPPING CHANNEL SEPARATION MEASUREMENT

APPLIED PROCEDURES / LIMIT

	Frequency hopping systems operating in the 2400-2483.5 MHz band may have hopping channel carrier frequencies that are separated by 25 kHz or two-thirds of the 20 dB bandwidth of the hopping channel, whichever is greater.
--	--

Spectrum Parameter	Setting
ZCTenuation	Auto
Span Frequency	> Measurement Bandwidth or Channel Separation
RB	100 kHz
VB	300 kHz
Detector	Peak
Trace	Max Hold
Sweep Time	Auto

6.1.1 TEST PROCEDURE

a.	The transmitter output (antenna port) was connected to the spectrum analyser in peak hold mode.
b.	The resolution bandwidth of 100 kHz and the video bandwidth of 300 kHz were utilised for channel separation measurement.

6.1.2 DEVIATION FROM STANDARD

No deviation.

6.1.3 TEST SETUP

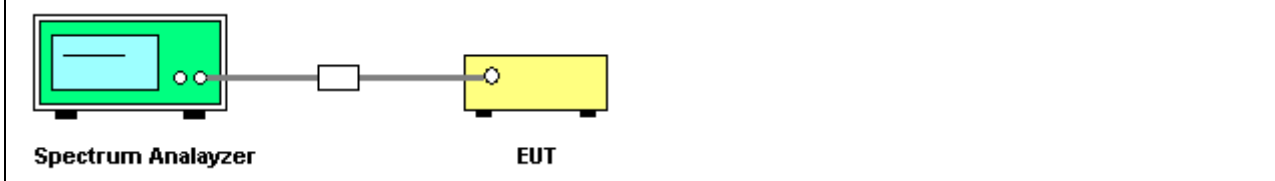

6.1.4 EUT OPERATION CONDITIONS

The EUT was programmed to be in continuously transmitting mode.

6.1.5 TEST RESULTS

EUT:	WiFi connected digital frame for streaming art	Model Name :	MEU020DC27
Temperature:	24 °C	Relative Humidity:	60%
Pressure:	1012 hPa	Test Voltage :	DC 12V from adapter,AC 120V/60Hz for adapter
Test Mode :	CH00 / CH39 /CH78 (1Mbps Mode)		

Frequency	Ch. Separation (MHz)	Result
2402 MHz	1.004	Complies
2441 MHz	1.001	Complies
2480 MHz	1.004	Complies

Ch. Separation Limits: >20dB bandwidth

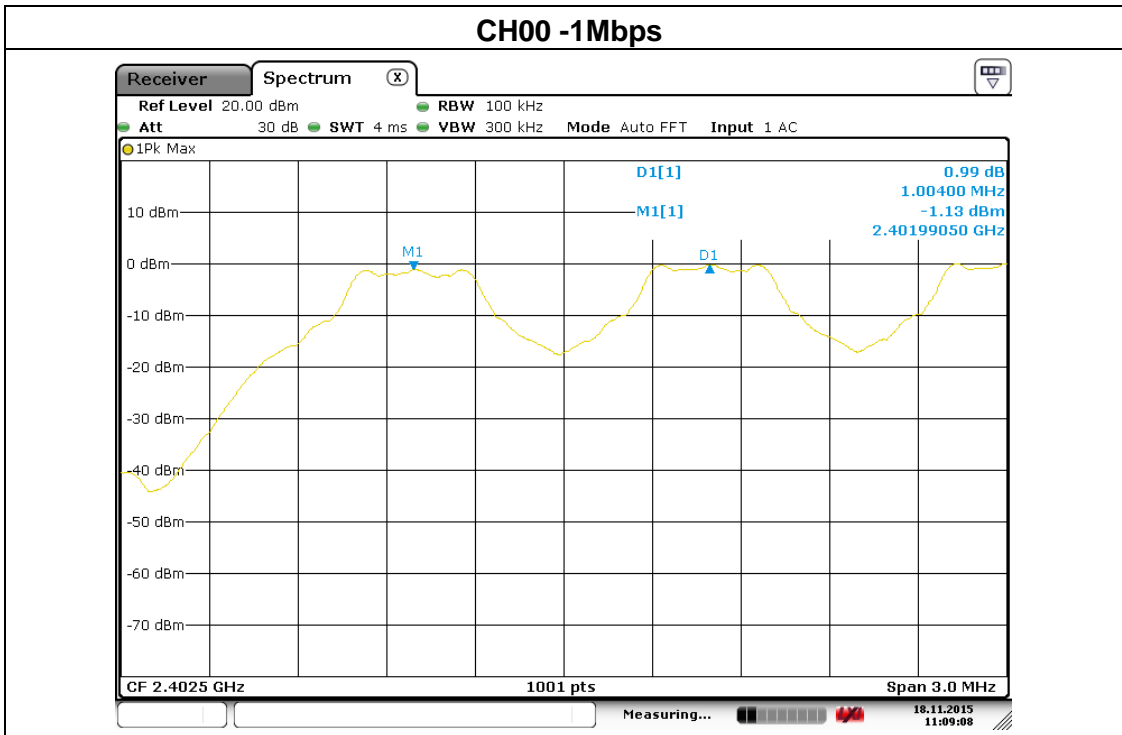

CH39 -1Mbps

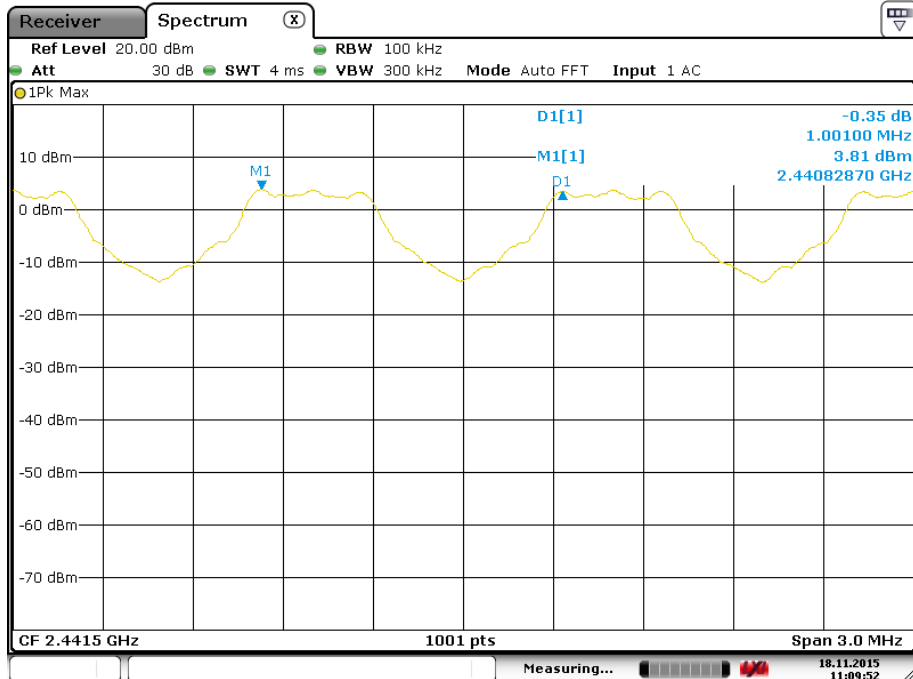

CH78 -1Mbps

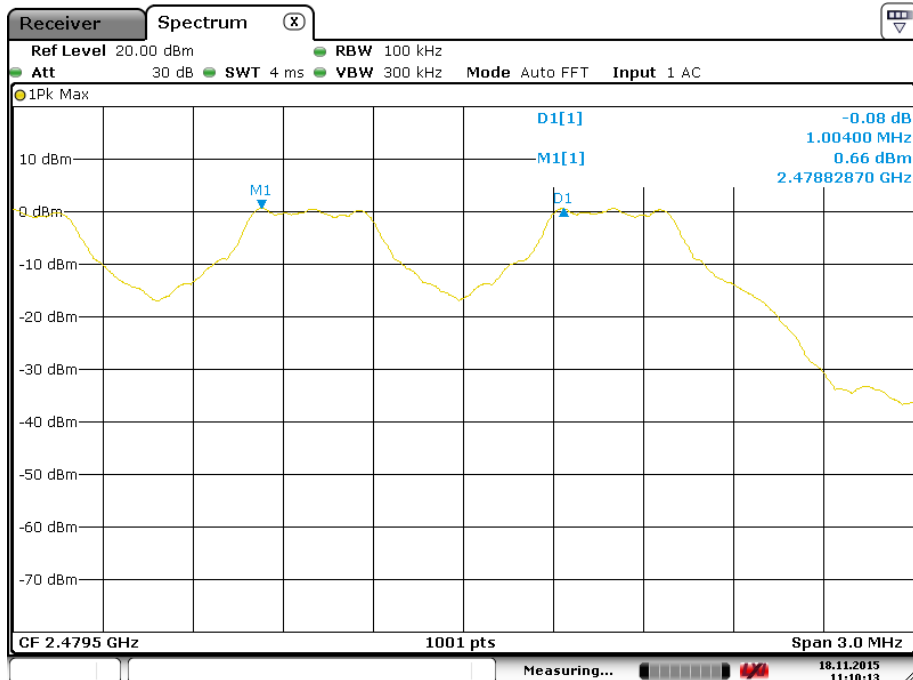

EUT:	WiFi connected digital frame for streaming art	Model Name :	MEU020DC27
Temperature:	24 °C	Relative Humidity:	60%
Pressure:	1012 hPa	Test Voltage :	DC 12V from adapter,AC 120V/60Hz for adapter
Test Mode :	CH00 / CH39 /CH78 (3Mbps Mode)		

Frequency	Ch. Separation (MHz)	Result
2402 MHz	1.007	Complies
2441 MHz	1.013	Complies
2480 MHz	1.004	Complies

Ch. Separation Limits: >20dB bandwidth

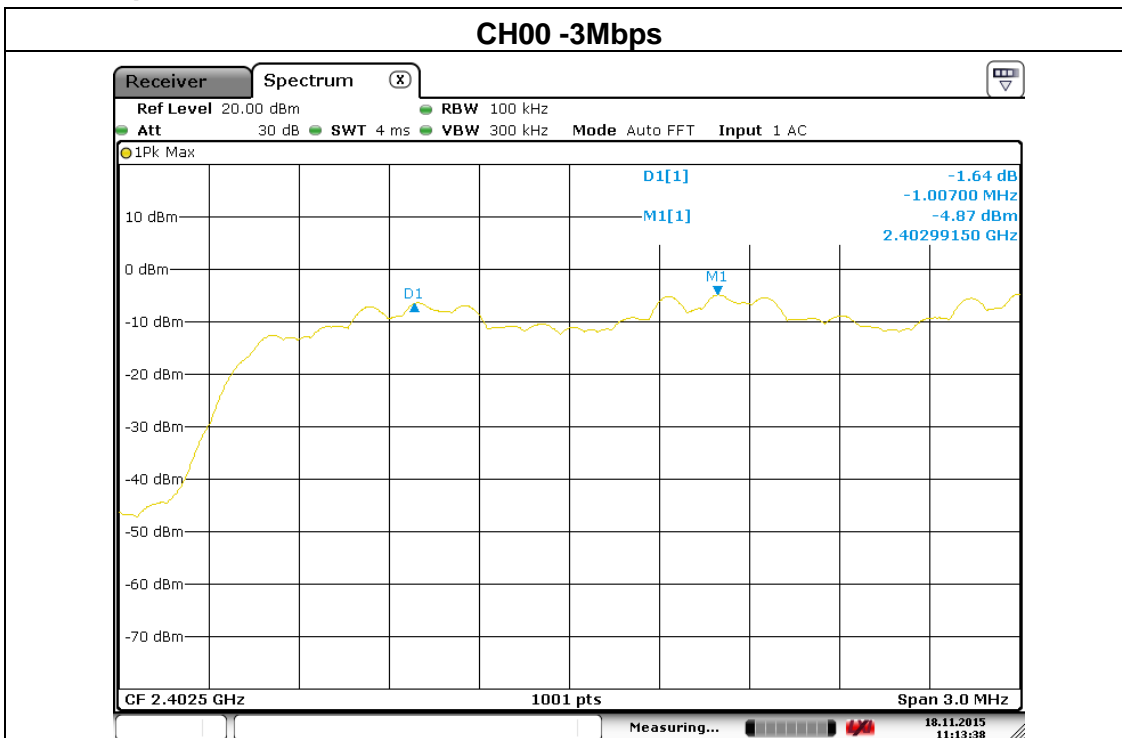

CH39 -3Mbps

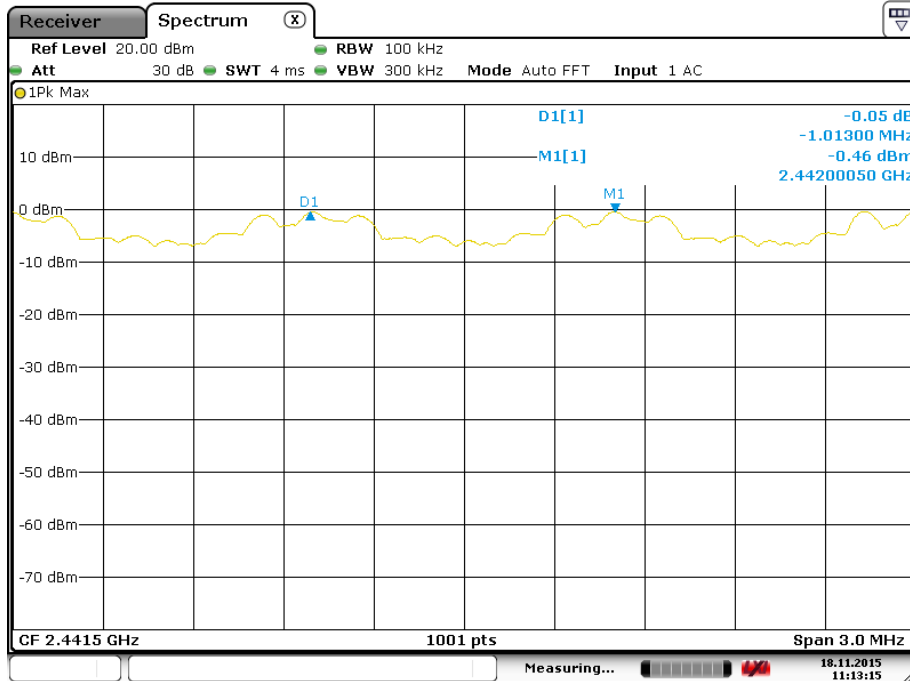

CH78 -3Mbps

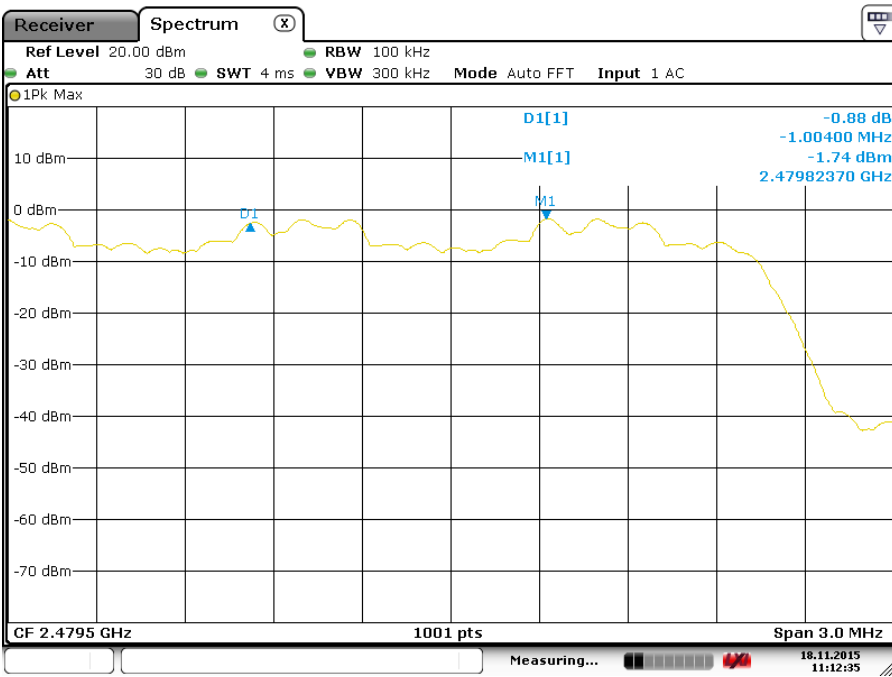

7. BANDWIDTH TEST

APPLIED PROCEDURES / LIMIT

FCC Part15 (15.247) , Subpart C				
Section	Test Item	Limit	Frequency Range (MHz)	Result
15.247 (a)(1)	Bandwidth	(20dB bandwidth)	2400-2483.5	PASS

Spectrum Parameter	Setting
ZCTenuation	Auto
Span Frequency	> Measurement Bandwidth or Channel Separation
RB	100 kHz
VB	300 kHz
Detector	Peak
Trace	Max Hold
Sweep Time	Auto

7.1.1 TEST PROCEDURE

- a. The EUT was directly connected to the spectrum analyzer and antenna output port as show in the block diagram below,
- b. Spectrum Setting : RBW= 100KHz, VBW=300KHz, Sweep time = Auto.

7.1.2 DEVIATION FROM STANDARD

No deviation.

7.1.3 TEST SETUP

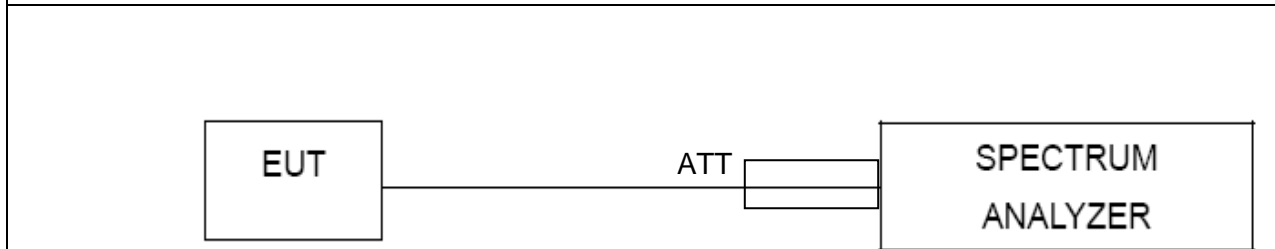

7.1.4 EUT OPERATION CONDITIONS

The EUT tested system was configured as the statements of 2.4 Unless otherwise a special operating condition is specified in the follows during the testing.

7.1.5 TEST RESULTS

EUT:	WiFi connected digital frame for streaming art	Model Name :	MEU020DC27
Temperature:	25 °C	Relative Humidity:	60%
Pressure:	1012 hPa	Test Voltage :	DC 12V from adapter,AC 120V/60Hz for adapter
Test Mode :	CH00 / CH39 /C78(1Mbps)		

Frequency	20dB Bandwidth (MHz)	Result
2402 MHz	1.0969	PASS
2441 MHz	1.0969	PASS
2480 MHz	1.0999	PASS

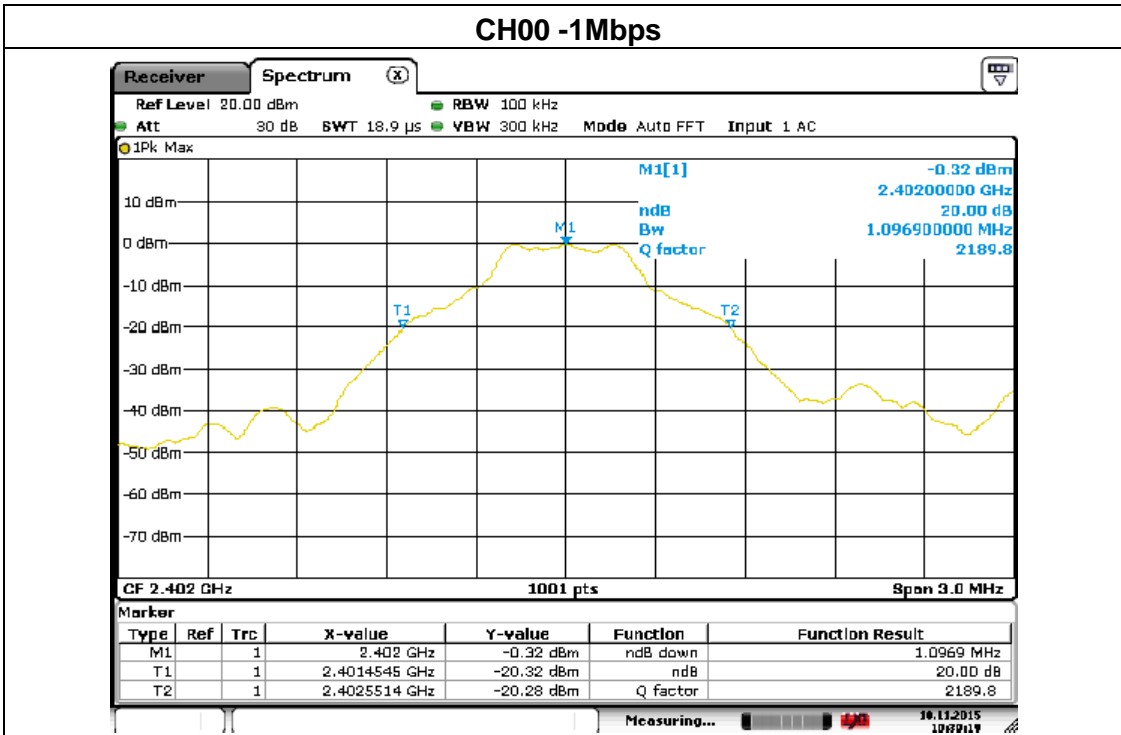

CH39 -1Mbps

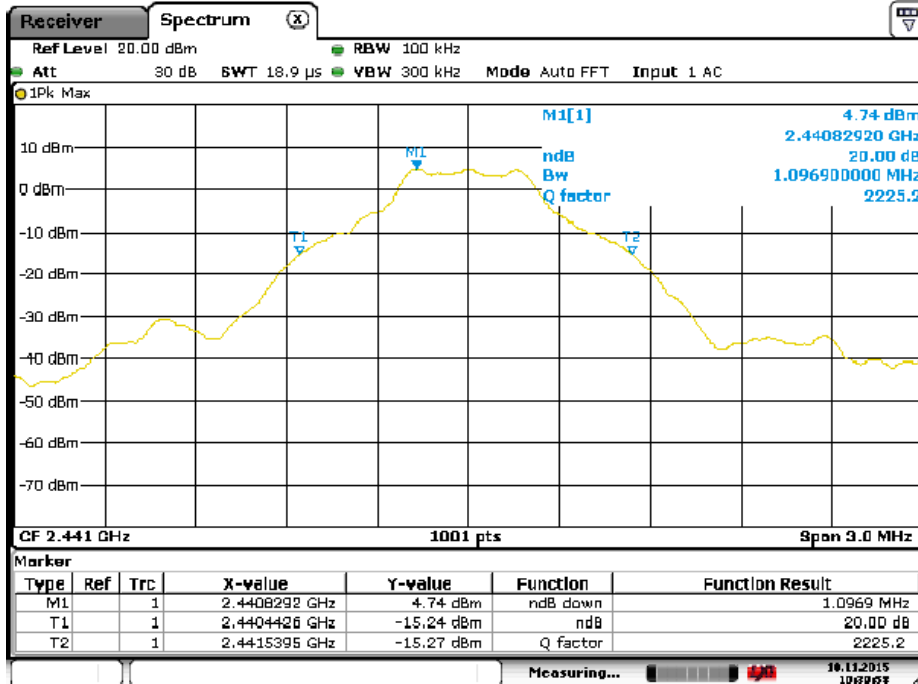

CH78 -1Mbps

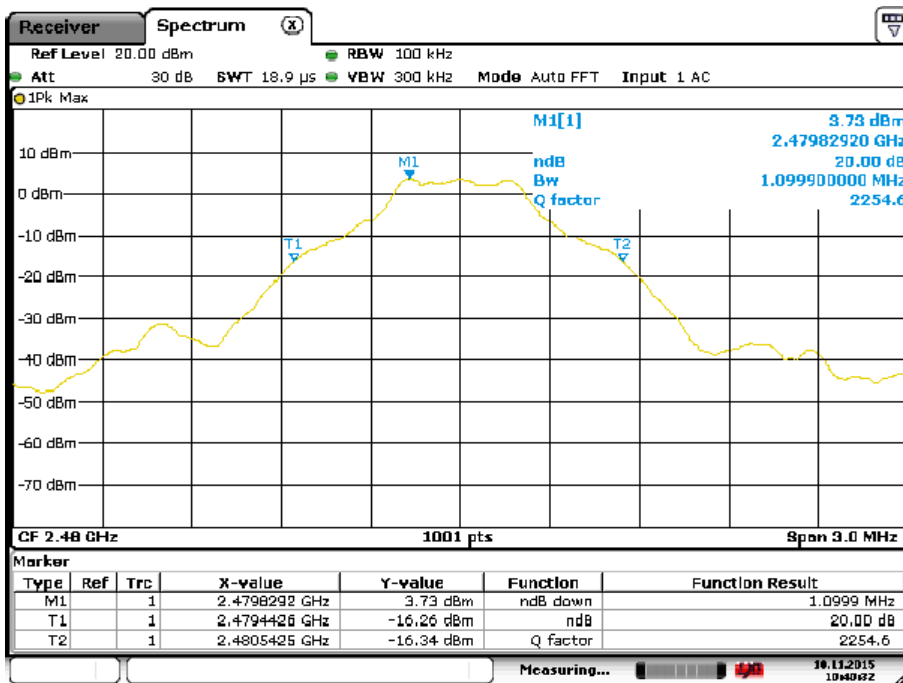

EUT:	WiFi connected digital frame for streaming art	Model Name :	MEU020DC27
Temperature:	25 °C	Relative Humidity:	60%
Pressure:	1012 hPa	Test Voltage :	DC 12V from adapter,AC 120V/60Hz for adapter
Test Mode :	CH00 / CH39 /C78(3Mbps)		

Frequency	20dB Bandwidth (MHz)	Result
2402 MHz	1.336	PASS
2441 MHz	1.339	PASS
2480 MHz	1.342	PASS

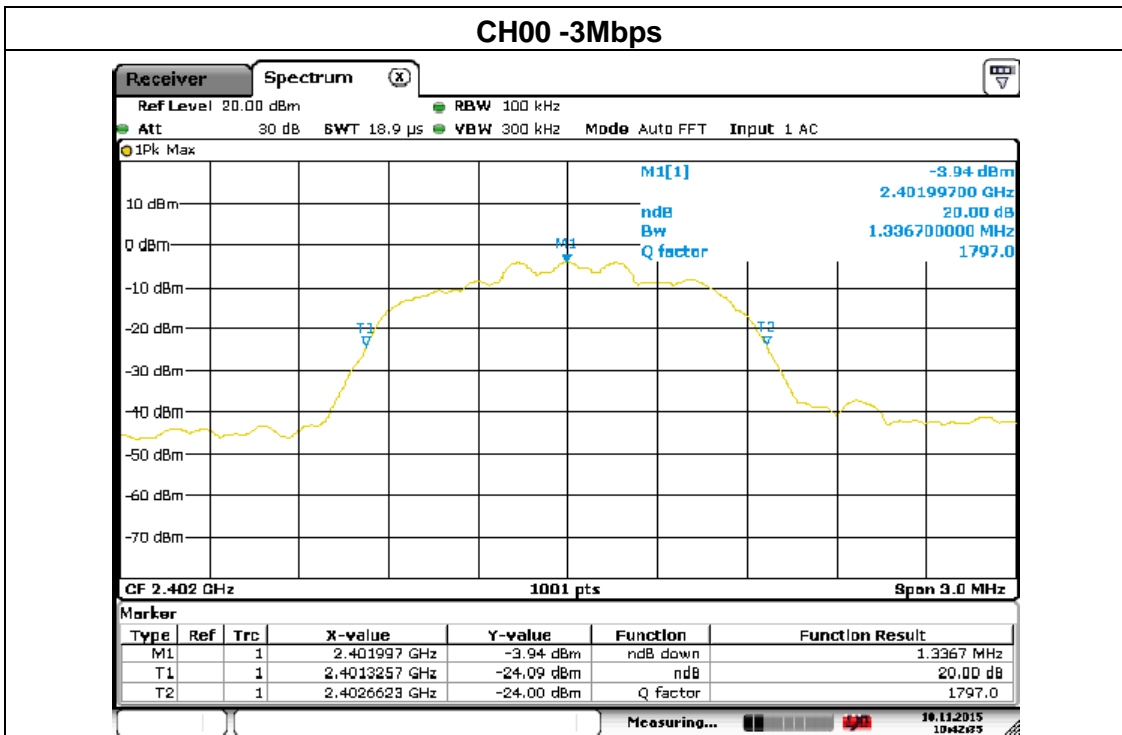

CH39 -3Mbps

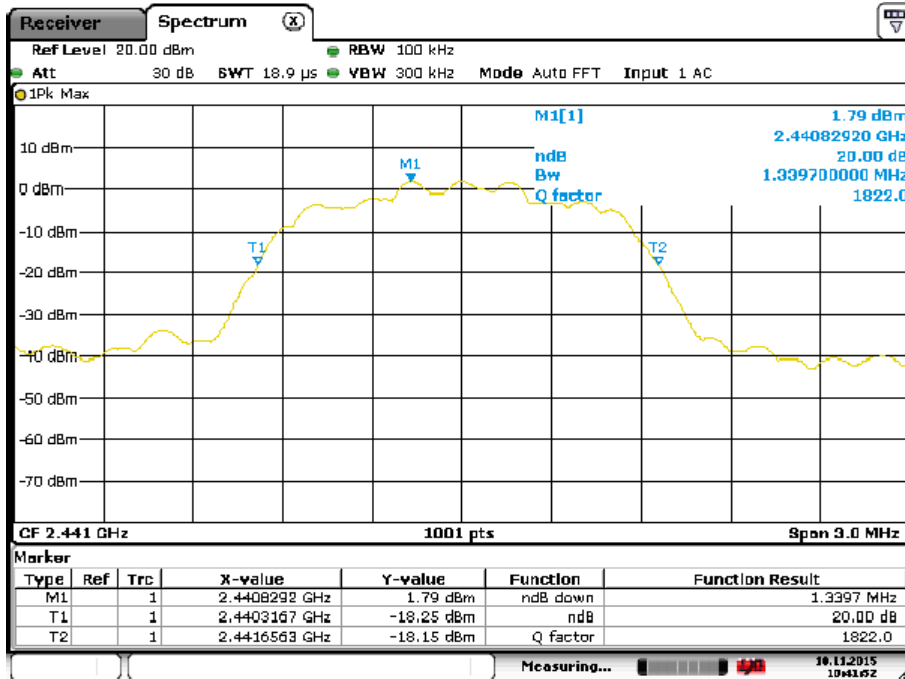

CH78 -3Mbps

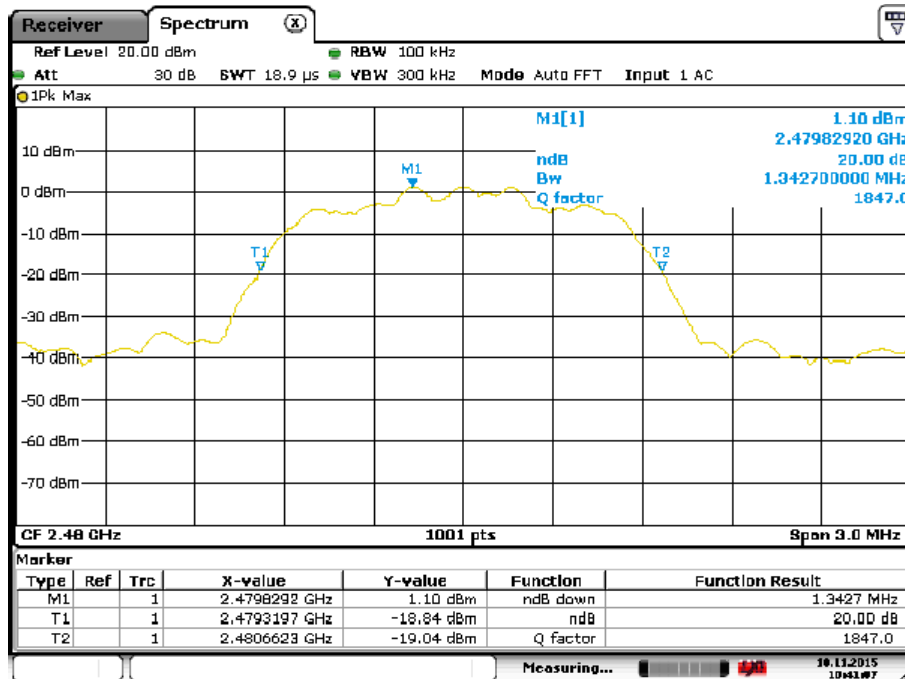

8. PEAK OUTPUT POWER TEST

APPLIED PROCEDURES / LIMIT

FCC Part15 (15.247) , Subpart C				
Section	Test Item	Limit	Frequency Range (MHz)	Result
15.247 (b)(i)	Peak Output Power	0.125 w or 1w	2400-2483.5	PASS

8.1.1 TEST PROCEDURE

a. Remove the antenna from the EUT and then connect a low loss RF cable from the antenna port to the Power Meter.

8.1.2 DEVIATION FROM STANDARD

No deviation.

8.1.3 TEST SETUP

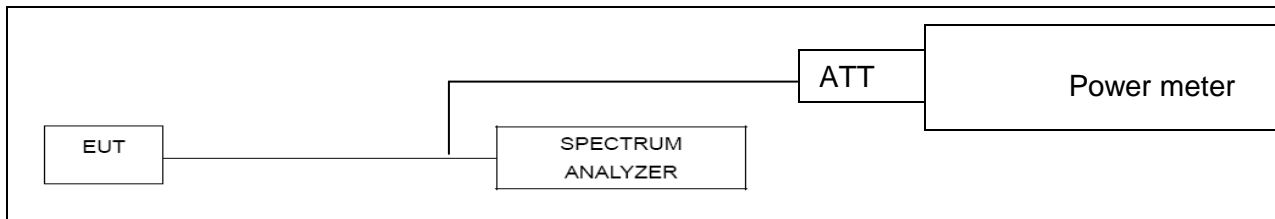

8.1.4 EUT OPERATION CONDITIONS

The EUT tested system was configured as the statements of 2.4 Unless otherwise a special operating condition is specified in the follows during the testing.

8.1.5 TEST RESULTS

EUT:	WiFi connected digital frame for streaming art	Model Name :	MEU020DC27
Temperature:	25 °C	Relative Humidity:	60%
Pressure:	1012 hPa	Test Voltage :	DC 12V from adapter,AC 120V/60Hz for adapter
Test Mode :	CH00/ CH39 /CH78		

Note: The relevant measured result has the offset with cable loss already.

1Mbps			
Test Channel	Frequency (MHz)	Peak Output Power (dBm)	LIMIT (dBm)
CH00	2402	2.15	30
CH39	2440	2.29	30
CH78	2480	2.23	30
3Mbps			
Test Channel	Frequency (MHz)	Peak Output Power (dBm)	LIMIT (dBm)
CH00	2402	1.88	21
CH39	2440	1.75	21
CH78	2480	1.13	21

9. 100 KHZ BANDWIDTH OF FREQUENCY BAND EDGE APPLICABLE STANDARD

In any 100 kHz bandwidth outside the frequency band in which the spread spectrum or digitally modulated intentional radiator is operating, the radio frequency power that is produced by the intentional radiator shall be at least 20 dB below that in the 100 kHz bandwidth within the band that contains the highest level of the desired power, based on either an RF conducted or a radiated measurement, provided the transmitter demonstrates compliance with the peak conducted power limits. If the transmitter complies with the conducted power limits based on the use of RMS averaging over a time interval, as permitted under paragraph (b)(3) of this section, the attenuation required under this paragraph shall be 30 dB instead of 20 dB. Attenuation below the general limits specified in §15.209(a) is not required. In addition, radiated emissions which fall in the restricted bands, as defined in §15.205(a), must also comply with the radiated emission limits specified in §15.209(a) (see §15.205(c)).

TEST PROCEDURE

- a) Check the calibration of the measuring instrument using either an internal calibrator or a known signal from an external generator.
- b) Position the EUT without connection to measurement instrument. Turn on the EUT and connect its antenna terminal to measurement instrument via a low loss cable. Then set it to any one measured frequency within its operating range, and make sure the instrument is operated in its linear range.
- c) Set RBW to 100 kHz and VBW of spectrum analyzer to 300 kHz with a convenient frequency span including 100 kHz bandwidth from band edge.
- d) Measure the highest amplitude appearing on spectral display and set it as a reference level. Plot the graph with marking the highest point and edge frequency.
- e) Repeat above procedures until all measured frequencies were complete.

9.1 DEVIATION FROM STANDARD

No deviation.

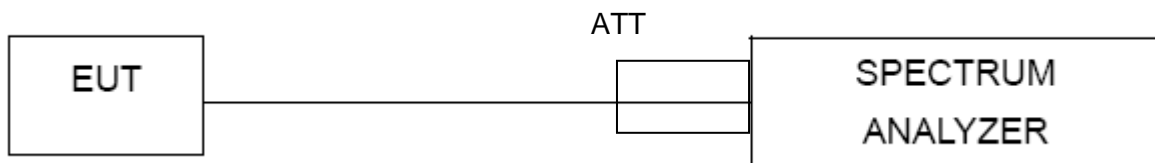
9.2 TEST SETUP**9.3 EUT OPERATION CONDITIONS**

The EUT tested system was configured as the statements of 2.4 Unless otherwise a special operating condition is specified in the follows during the testing.

9.4 TEST RESULTS

EUT:	WiFi connected digital frame for streaming art	Model Name :	MEU020DC27
Temperature:	24 °C	Relative Humidity:	60%
Pressure:	1012 hPa	Test Voltage :	DC 12V from adapter,AC 120V/60Hz for adapter

Frequency Band (MHz)	Delta Peak to band emission (dBc)	> Limit (dBc)	Result
1Mbps Non-hopping			
≤2400	44.84	20	Pass
≥2483.5	59.52	20	Pass
1Mbps hopping			
≤2400	48.63	20	Pass
≥2483.5	62.15	20	Pass

Frequency (MHz)	Meter Reading (dBμV)	Factor (dB)	Emission Level (dBμV/m)	Limits (dBμV/m)	Margin (dB)	Detector Type	Comment
1Mbps Non-hopping							
2390.0	56.14	-13.06	43.08	54.00	-10.92	peak	Vertical
2390.0	58.73	-13.06	45.67	54.00	-8.33	peak	Horizontal
2483.5	56.52	-12.78	43.74	54.00	-10.26	peak	Vertical
2483.5	57.11	-12.78	44.33	54.00	-9.67	peak	Horizontal

Frequency (MHz)	Meter Reading (dBμV)	Factor (dB)	Emission Level (dBμV/m)	Limits (dBμV/m)	Margin (dB)	Detector Type	Comment
1Mbps hopping							
2390.0	55.23	-13.06	42.17	54.00	-11.83	peak	Vertical
2390.0	54.17	-13.06	41.11	54.00	-12.89	peak	Horizontal
2483.5	53.52	-12.78	40.74	54.00	-13.26	peak	Vertical
2483.5	54.35	-12.78	41.57	54.00	-12.43	peak	Horizontal

Note: Test method to see chapter 3.2 . When PK value is lower than the Average value limit, average didn't record.

Band Edge, Left Side

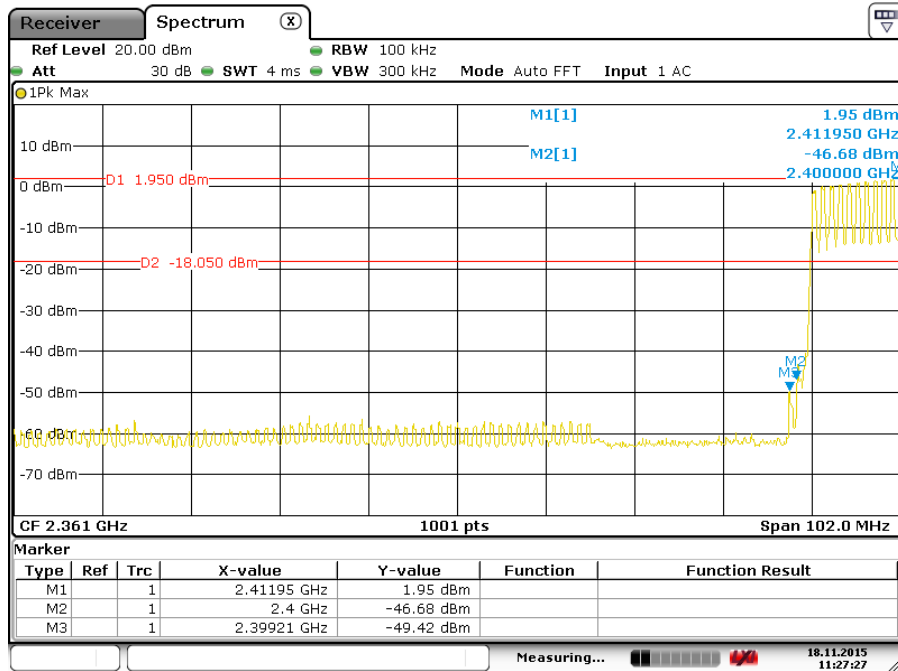
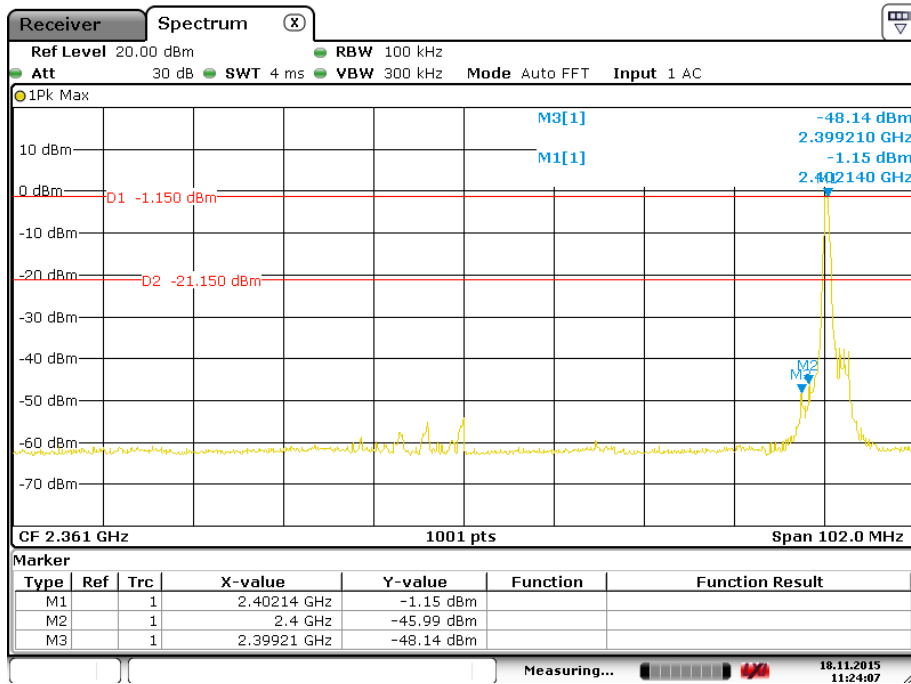

Band Edge, Right Side

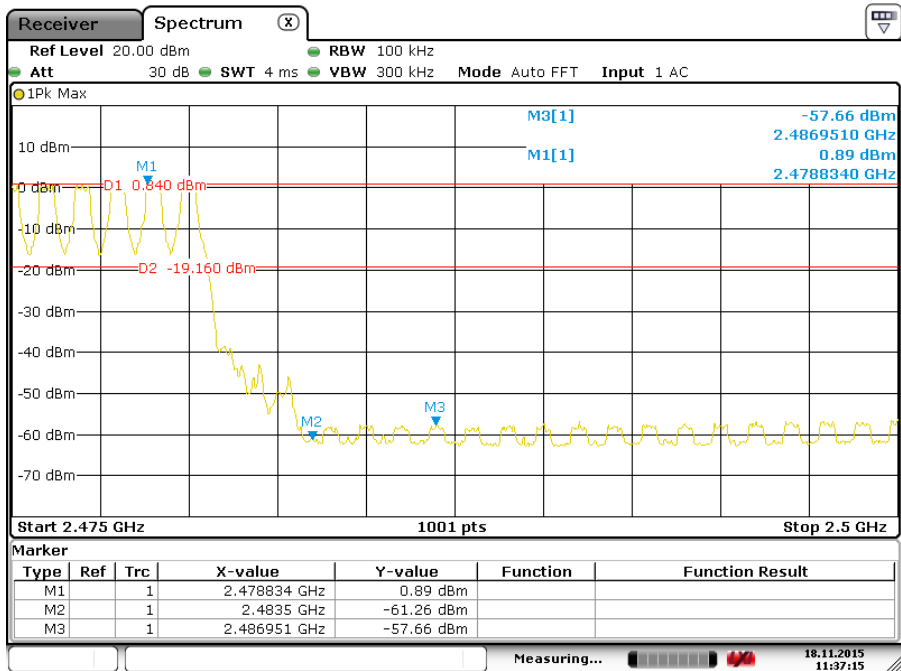
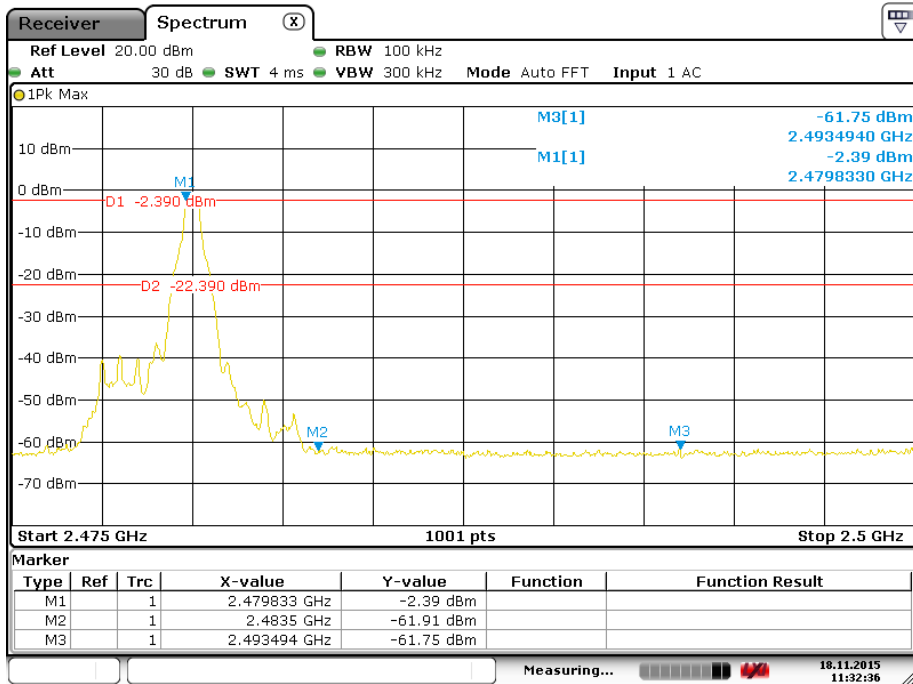

EUT:	WiFi connected digital frame for streaming art	Model Name :	MEU020DC27
Temperature:	24 °C	Relative Humidity:	60%
Pressure:	1012 hPa	Test Voltage :	DC 12V from adapter, AC 120V/60Hz for adapter

Frequency Band	Delta Peak to band emission (dBc)	> Limit (dBc)	Result
3Mbps Non-hopping			
≤2400	50.38	20	Pass
≥2483.5	57.32	20	Pass
3Mbps hopping			
≤2400	55.55	20	Pass
≥2483.5	59.10	20	Pass

Frequency (MHz)	Meter Reading (dBμV)	Factor (dB)	Emission Level (dBμV/m)	Limits (dBμV/m)	Margin (dB)	Detector Type	Comment
3Mbps Non-hopping							
2390	55.23	-13.06	42.17	54.00	-11.83	peak	Vertical
2390	58.21	-13.06	45.15	54.00	-8.85	peak	Horizontal
2483.5	57.09	-12.78	44.31	54.00	-9.69	peak	Vertical
2483.5	57.16	-12.78	44.38	54.00	-9.62	peak	Horizontal

Frequency (MHz)	Meter Reading (dBμV)	Factor (dB)	Emission Level (dBμV/m)	Limits (dBμV/m)	Margin (dB)	Detector Type	Comment
3Mbps hopping							
2390	53.52	-13.06	40.46	54.00	-13.54	peak	Vertical
2390	55.17	-13.06	42.11	54.00	-11.89	peak	Horizontal
2483.5	54.49	-12.78	41.71	54.00	-12.29	peak	Vertical
2483.5	58.36	-12.78	45.58	54.00	-8.42	peak	Horizontal

Note: Test method to see chapter 3.2 . When PK value is lower than the Average value limit, average didn't record.

Band Edge, Left Side

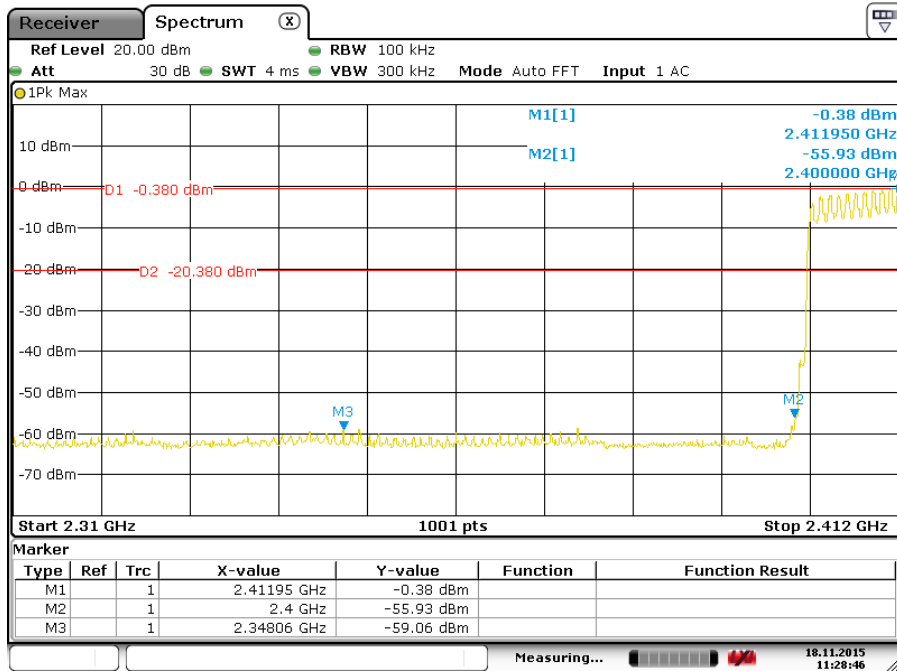
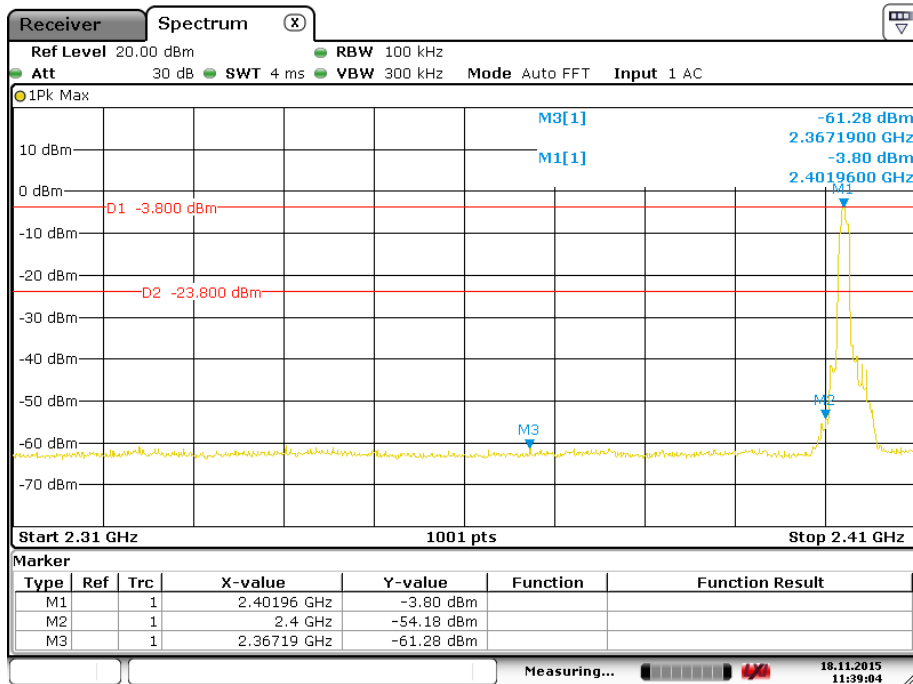

Band Edge, Right Side

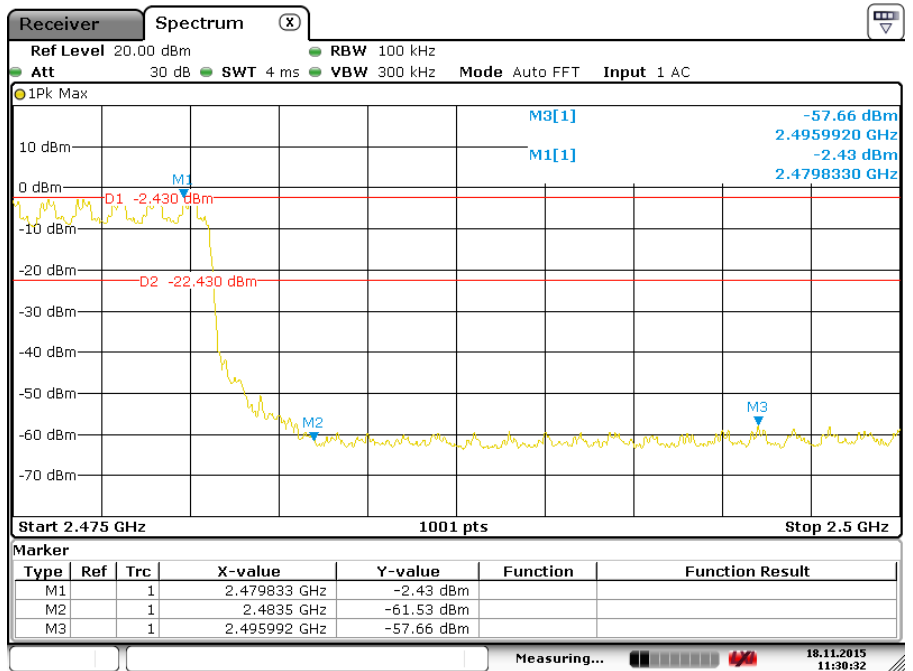
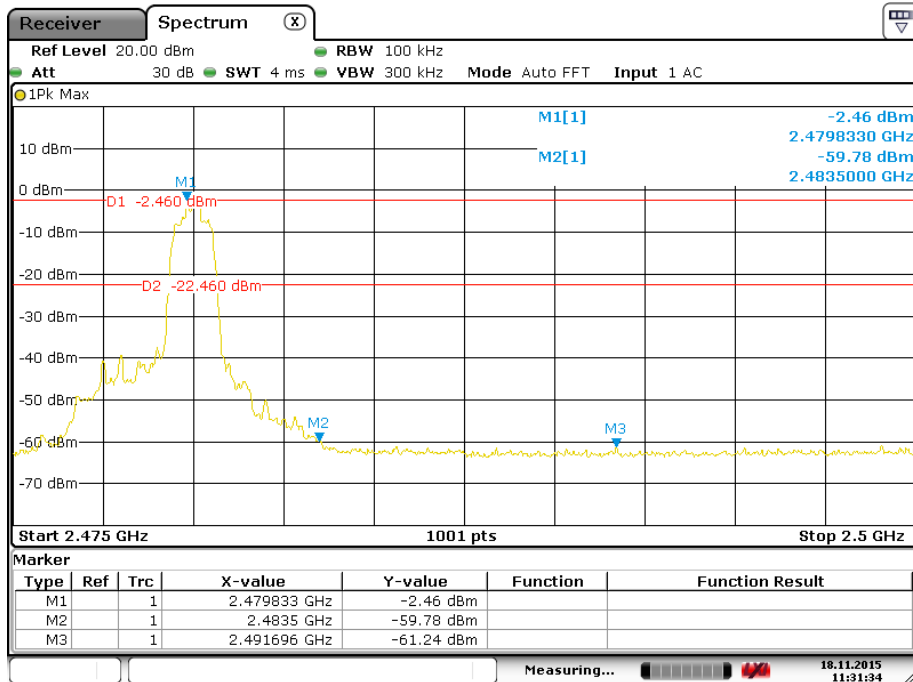

10. ANTENNA REQUIREMENT

STANDARD REQUIREMENT

15.203 requirement: For intentional device, according to 15.203: an intentional radiator shall be designed to ensure that no antenna other than that furnished by the responsible party shall be used with the device.

EUT ANTENNA

The EUT antenna is PCB Antenna. Use ipex antenna connector. It comply with the standard requirement.

11. EUT TEST PHOTO

Conducted Measurement Photos



Radiated Measurement Photos

Between 30MHz-1GHz

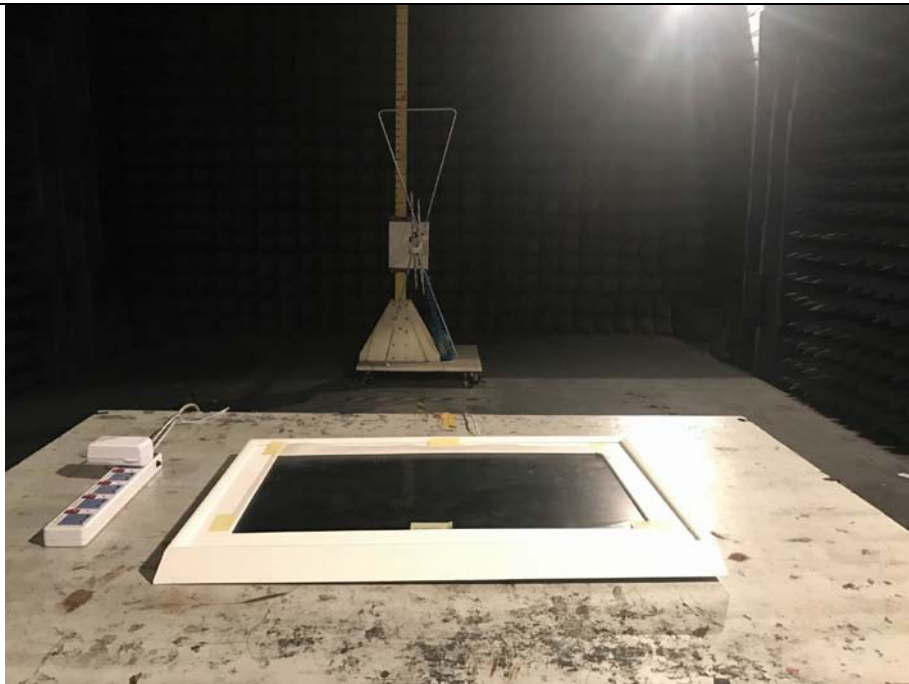

Shenzhen ZCT Technology Co., Ltd.

3/F., Building 5, Hongsheng Industrial Zone, Bao'an Road, Xixiang Street, Bao'an District, Shenzhen, Guangdong, China.

Tel: 400-805-1899 Fax: 86-755-23702323; <http://www.renzhengjiance.com>

Above 1GHz

