

# FCC TEST REPORT

**Test report  
On Behalf of  
Shenzhen Sunrise Rich Electronics Technology Co., Ltd.  
For  
Bluetooth speaker  
Model No.: LS-77, LS-20, LS-79, LS-XX  
FCC ID: 2AFRNLS-XX**

**Prepared for :** Shenzhen Sunrise Rich Electronics Technology Co., Ltd.  
Flr. 5 , D Bldg ,Dingfeng Science Technology Park , Great Wall Road ,  
Shiyan Street, Bao'an District , Shenzhen City ,China

**Prepared By :** Shenzhen WST Testing Technology Co., Ltd.  
1F, No.9 Building,TGK Science & Technology Park, Yangtian Rd., NO.72  
Bao'an Dist., Shenzhen, Guangdong, China. 518101

**Date of Test:** Sep. 02, 2015 ~ Sep. 10, 2015

**Date of Report:** Sep. 10, 2015

**Report Number:** WST15009104-E

### TEST RESULT CERTIFICATION

**Applicant's name** ..... : Shenzhen Sunrise Rich Electronics Technology Co., Ltd.  
Address ..... : Flr. 5 , D Bldg ,Dingfeng Science Technology Park , Great Wall Road , Shiyan Street, Bao'an District , Shenzhen City ,China  
**Manufacture's Name**..... : Shenzhen Sunrise Rich Electronics Technology Co., Ltd.  
Address ..... : Flr. 5 , D Bldg ,Dingfeng Science Technology Park , Great Wall Road , Shiyan Street, Bao'an District , Shenzhen City ,China

**Product description**

Trade Mark: OEM  
Product name ..... : Bluetooth speaker  
Model and/or type reference : LS-77, LS-20, LS-79, LS-XX  
**Standards** ..... : FCC Rules and Regulations Part 15 Subpart C Section 15.249  
ANSI C63.4: 2014

This publication may be reproduced in whole or in part for non-commercial purposes as long as the WST Certification & Testing (HK) Limited is acknowledged as copyright owner and source of the material. WST Certification & Testing (HK) Limited takes no responsibility for and will not assume liability for damages resulting from the reader's interpretation of the reproduced material due to its placement and context.

**Date of Test** ..... :  
Date (s) of performance of tests ..... : **Sep. 02, 2015 ~ Sep. 10, 2015**  
Date of Issue..... : **Sep. 10, 2015**  
Test Result..... : **Pass**

Testing Engineer : Eric Xie  
(Eric Xie)

Technical Manager : Dora Qin  
(Dora Qin)

Authorized Signatory : Michael Ling  
(Michael Ling)

<b>Table of Contents</b>	<b>Page</b>
1. . TEST SUMMARY	4
2. . GENERAL INFORMATION	5
2.1. General Description of EUT	5
2.2. Carrier Frequency of Channels	6
2.3. Operation of EUT during testing	6
2.4. Description of Test Setup	6
2.5. Measurement Instruments List	7
3. . CONDUCTED EMISSION TEST	9
3.1. Block Diagram of Test Setup	9
3.2. Conducted Power Line Emission Limit	9
4 RADIATED EMISSION TEST	11
4.2 Limits	12
4.3 Test Procedure	12
4.4 Test Result	13
5 BAND EDGE	17
5.3 Test Procedure	17
5.4 Test Result	17
6 OCCUPIED BANDWIDTH MEASUREMENT	22
6.3Test Procedure	22
6.3 Test Result	22
7 Antenna Requirement	25
8 Photograph of Test	26

## 1.. TEST SUMMARY

### 1.1. Description of Test

Description of Test	Result
CONDUCTED EMISSIONS TEST	Compliant
RADIATED EMISSION TEST	Compliant
BAND EDGE	Compliant
OCCUPIED BANDWIDTH MEASUREMENT	Compliant
ANTENNA REQUIREMENT	Compliant

### 1.2. Test Facility

Test Firm : Shenzhen WST Testing Technology Co., Ltd.  
Certificated by FCC, Registration No.: 939433  
Address : 1F, No.9 Building, TGK Science & Technology Park, Yangtian Rd., NO.72  
Bao'an Dist., Shenzhen, Guangdong, China. 518101  
Tel : (86)755-33916437  
Fax : (86)755-27822175

### 1.3. Measurement Uncertainty

#### Measurement Uncertainty

Conducted Emission Expanded Uncertainty = 2.23dB, k=2  
Radiated emission expanded uncertainty(9kHz-30MHz) = 3.08dB, k=2  
Radiated emission expanded uncertainty(30MHz-1000MHz) = 4.42dB, k=2  
Radiated emission expanded uncertainty(Above 1GHz) = 4.06dB, k=2

## 2.. GENERAL INFORMATION

### 2.1. General Description of EUT

Equipment	Bluetooth speaker
Model Name	LS-77, LS-20, LS-79, LS-XX
Serial No	/
FCC ID	2AFRNLS-XX
Model Difference	All the model are the same circuit and RF module,except the appearance colour, this report only test mode name: LS-77.
Modulation Type	GFSK
Antenna Type	Internal
Antenna Gain	0 dBi
BT Operation frequency	2402-2480MHz (BT2.1+EDR)
Number of Channels	79
Data Rate	/
Modulation Type	/
Power Source	/
Power Rating	DC 3.7V
Adapter Model	/

## 2.2. Carrier Frequency of Channels

Frequency Band	Channel Number	Frequency
2402~2480MHZ	0	2402MHZ
	1	2403MHZ
	:	:
	38	2440 MHZ
	39	2441 MHZ
	40	2442 MHZ
	:	:
	77	2479 MHZ
	78	2480 MHZ

## 2.3. Operation of EUT during testing

## Operating Mode

The mode is used: **Transmitting mode**

Low Channel: 2402MHz

Middle Channel: 2441MHz

High Channel: 2480MHz

## 2.4. Description of Test Setup

Operation of EUT during testing



**2.5. Measurement Instruments List**

Item	Equipment	Manufacturer	Model No.	Serial No.	Last Cal.	Cal. Interval
1.	EMI Receiver	Rohde & Schwarz	ESCI	100627	May 19, 2015	1 Year
2.	LISN	SchwarzBeck	NSLK 8126	8126377	May 19, 2015	1 Year
3.	RF Switching Unit	Compliance Direction	RSU-M2	38303	May 19, 2015	1 Year
4.	EMI Test Software ES-K1	Rohde & Schwarz	N/A	N/A	N/A	N/A
5.	EMI Test Receiver	Rohde & Schwarz	ESCI	100627	May 19, 2015	1 Year
6.	Trilog Broadband Antenna	Schwarzbeck	VULB9163	VULB 9163-289	May 17, 2015	1 Year
7.	Pre-amplifier	Compliance Direction	PAP-0203	22008	May 19, 2015	1 Year
8.	EMI Test Software EZ-EMC	SHURPLE	N/A	N/A	N/A	N/A
9.	EMI Receiver	Rohde & Schwarz	ESCI	100627	May 19, 2015	1 Year
10.	LISN	SchwarzBeck	NSLK 8126	8126377	May 19, 2015	1 Year
11.	RF Switching Unit	Compliance Direction	RSU-M2	38303	May 19, 2015	1 Year
12.	EMI Test Software ES-K1	Rohde & Schwarz	N/A	N/A	N/A	N/A
13.	EMI Receiver	Rohde & Schwarz	ESCI	100627	May 19, 2015	1 Year
14.	EMI Receiver	Rohde & Schwarz	ESCI	100627	May 19, 2015	1 Year
15.	LISN	SchwarzBeck	NSLK 8126	8126377	May 19, 2015	1 Year
16.	RF Switching Unit	Compliance Direction	RSU-M2	38303	May 19, 2015	1 Year
17.	EMI Test Software ES-K1	Rohde & Schwarz	N/A	N/A	N/A	N/A
18.	Programmable AC Power source	SOPH POWER	PAG-1050	630250	May 26, 2015	1 Year
19.	Harmonic and Flicker Analyzer	LAPLACE	AC2000A	272629	May 26, 2015	1 Year
20.	Harmonic and Flicker Test Software AC 2000A	LAPLACE	N/A	N/A	N/A	N/A
21.	ESD Simulators	KIKUSUI	KES4021	LJ003477	May 25, 2015	1 Year
22.	EFT Generator	EMPEK	EFT-4040B	0430928N	May 19, 2015	1 Year
23.	Shielding Room	ChangZhou ZhongYu	JB88	SEL0166	May 19, 2015	1 Year
24.	Signal Generator 9KHz~2.2GHz	R&S	SML02	SEL0143	May 19, 2015	1 Year
25.	Signal Generator 9KHz~1.1GHz	R&S	SML01	SEL0135	May 19, 2015	1 Year
26.	Power Meter	R&S	NRVS	SEL0144	May 19, 2015	1 Year
27.	RF Level Meter		URV35	SEL0137	May 19, 2015	1 Year
28.	Audio Analyzer	R&S	UPL	SEL0136	May 19, 2015	1 Year

29.	RF-Amplifier 150KHz~150MH z	BONN Elektronik	BSA1515-25	SEL0157	May 19, 2015	1 Year
30.	Stripline Test Cell	Erika Fiedler	VDE0872	SEL0167	N/A	N/A
31.	TV Test Transmitter	R&S	SFM	SEL0159	May 17, 2015	1 Year
32.	TV Generator PAL	R&S	SGPF	SEL0138	May 19, 2015	1 Year
33.	TV Generator Ntsc	R&S	SGMF	SEL0140	May 19, 2015	1 Year
34.	TV Generator Secam	R&S	SGSF	SEL0139	May 19, 2015	1 Year
35.	TV Test Transmitter 0.3MHz~3300MHz	R&S	SFQ	SEL0142	May 19, 2015	1 Year
36.	MPEG2 Measurement Generator	R&S	DVG	SEL0141	May 19, 2015	1 Year
37.	Spectrum Analyzer	R&S	FSP	SEL0177	May 19, 2015	1 Year
38.	Matching	R&S	RAM	SEL0146	N/A	N/A
39.	Matching	R&S	RAM	SEL0148	N/A	N/A
40.	Absorbing Clamp	R&S	MDS21	SEL0158	May 17, 2015	1 Year
41.	Coupling Set	Erika Fiedler	Rco, Rci, MC, AC, LC	SEL0149	N/A	N/A
42.	Filters	Erika Fiedler	Sr, LBS	SEL0150	N/A	N/A
43.	Matching Network	Erika Fiedler	MN, T1	SEL0151	N/A	N/A
44.	Fully Anechoic Room	ChangZhou ZhongYu	854	SEL0169	Jun. 10, 2015	1 Year
45.	Signal Generator	R&S	SML03	SEL0068	May 17, 2015	1 Year
46.	RF-Amplifier 30M~1GHz	Amplifier Reasearch	250W1000A	SEL0066	Oct. 24, 2014	1 Year
47.	RF-Amplifier 0.8~3.0GHz	Amplifier Reasearch	60S1G3	SEL0065	Oct. 24, 2014	1 Year
48.	Power Meter	R&S	NRVD	SEL0069	May 17, 2015	1 Year
49.	Power Sensor	R&S	URV5-Z2	SEL0071	May 17, 2015	1 Year
50.	Power Sensor	R&S	URV5-Z2	SEL0072	May 17, 2015	1 Year
51.	Software EMC32	R&S	EMC32-S	SEL0082	N/A	N/A
52.	Log-periodic Antenna	Amplifier Reasearch	AT1080	SEL0073	N/A	N/A
53.	Antenna Tripod	Amplifier Reasearch	TP1000A	SEL0074	N/A	N/A
54.	High Gain Horn Antenna(0.8-5G Hz)	Amplifier Reasearch	AT4002A	SEL0075	N/A	N/A



### 3.. CONDUCTED EMISSION TEST

#### 3.1. Block Diagram of Test Setup

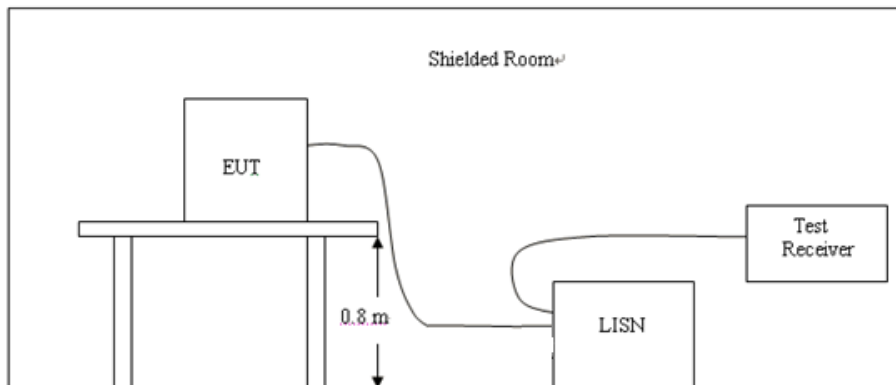

#### 3.2. Conducted Power Line Emission Limit

For unintentional device, according to § 15.107(a) Line Conducted Emission Limits is as following

Frequency (MHz)	Maximum RF Line Voltage (dBµV)			
	CLASS A		CLASS B	
	Q.P.	Ave.	Q.P.	Ave.
0.15 - 0.50	79	66	66-56*	56-46*
0.50 - 5.00	73	60	56	46
5.00 - 30.0	73	60	60	50

\* Decreasing linearly with the logarithm of the frequency

For intentional device, according to §15.207(a) Line Conducted Emission Limit is same as above table.

#### 3.3. Test Procedure

- 1, The equipment was set up as per the test configuration to simulate typical actual usage per the user's manual. The EUT is a tabletop system, a wooden table with a height of 0.8 meters is used and is placed on the ground plane as per ANSI C63.4.
- 2, Support equipment, if needed, was placed as per ANSI C63.4.
- 3, All I/O cables were positioned to simulate typical actual usage as per ANSI C63.4.
- 4, If a EUT received DC power from the USB Port of Notebook PC, the PC's adapter received AC120V/60Hz power through a Line Impedance Stabilization Network (LISN) which supplied power source and was grounded to the ground plane.
- 5, All support equipments received AC power from a second LISN, if any.
- 6, The EUT test program was started. Emissions were measured on each current carrying line of the EUT using a spectrum Analyzer / Receiver connected to the LISN powering the EUT. The LISN has two monitoring points: Line 1 (Hot Side) and Line 2 (Neutral Side). Two scans were taken: one with Line 1 connected to Analyzer / Receiver and Line 2 connected to a 50 ohm load; the second scan had Line 1 connected to a 50 ohm load and Line 2 connected to the Analyzer / Receiver.
- 7, Analyzer / Receiver scanned from 150 KHz to 30MHz for emissions in each of the test modes

3.4. Test Result

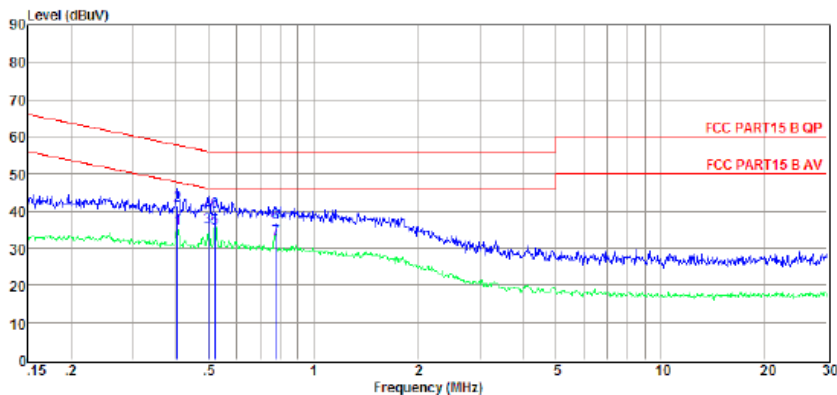

Item (Mark)	Freq (MHz)	Read Level (dBµV)	LISN Factor (dB)	Cable Loss (dB)	Pulse Limiter Factor (dB)	Result Level (dBµV)	Limit Line (dBµV)	Over Limit (dB)	Detector	Phase
1	0.41	15.65	9.63	0.03	9.86	35.17	47.73	-12.56	Average	LINE
2	0.41	21.99	9.63	0.03	9.86	41.51	57.73	-16.22	QP	LINE
3	0.50	15.99	9.63	0.03	9.87	35.52	46.05	-10.53	Average	LINE
4	0.50	20.08	9.63	0.03	9.87	39.61	56.05	-16.44	QP	LINE
5	0.52	15.86	9.63	0.03	9.87	35.39	46.00	-10.61	Average	LINE
6	0.52	20.41	9.63	0.03	9.87	39.94	56.00	-16.06	QP	LINE
7	0.78	12.78	9.62	0.08	9.86	32.34	46.00	-13.66	Average	LINE
8	0.78	17.27	9.62	0.08	9.86	36.83	56.00	-19.17	QP	LINE

Note: 1. Result Level = Read Level + LISN Factor + Pulse Limiter Factor + Cable loss.  
 2. If QP Result complies with AV limit, AV Result is deemed to comply with AV limit.  
 3. Test setup: RBW: 200 Hz (9 kHz—150 kHz), 9 kHz (150 kHz—30 MHz), Step size: 4 kHz, Scan time: auto.

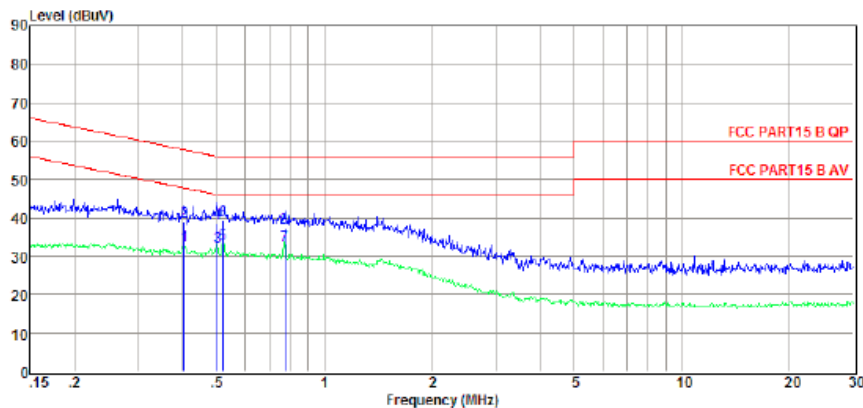

Item (Mark)	Freq (MHz)	Read Level (dBµV)	LISN Factor (dB)	Cable Loss (dB)	Pulse Limiter Factor (dB)	Result Level (dBµV)	Limit Line (dBµV)	Over Limit (dB)	Detector	Phase
1	0.41	13.17	9.61	0.03	9.86	32.67	47.73	-15.06	Average	NEUTRAL
2	0.41	19.49	9.61	0.03	9.86	38.99	57.73	-18.74	QP	NEUTRAL
3	0.50	12.95	9.61	0.03	9.87	32.46	46.00	-13.54	Average	NEUTRAL
4	0.50	19.02	9.61	0.03	9.87	38.53	56.00	-17.47	QP	NEUTRAL
5	0.52	13.53	9.61	0.03	9.87	33.04	46.00	-12.96	Average	NEUTRAL
6	0.52	19.68	9.61	0.03	9.87	39.19	56.00	-16.81	QP	NEUTRAL
7	0.78	13.23	9.61	0.08	9.86	32.78	46.00	-13.22	Average	NEUTRAL
8	0.78	17.89	9.61	0.08	9.86	37.44	56.00	-18.56	QP	NEUTRAL

Note: 1. Result Level = Read Level + LISN Factor + Pulse Limiter Factor + Cable loss.  
 2. If QP Result complies with AV limit, AV Result is deemed to comply with AV limit.  
 3. Test setup: RBW: 200 Hz (9 kHz—150 kHz), 9 kHz (150 kHz—30 MHz), Step size: 4 kHz, Scan time: auto.

4 RADIATED EMISSION TEST

4.1 Block Diagram of Test Setup

(1) Radiated Emission Test-Up Frequency Below 30MHz

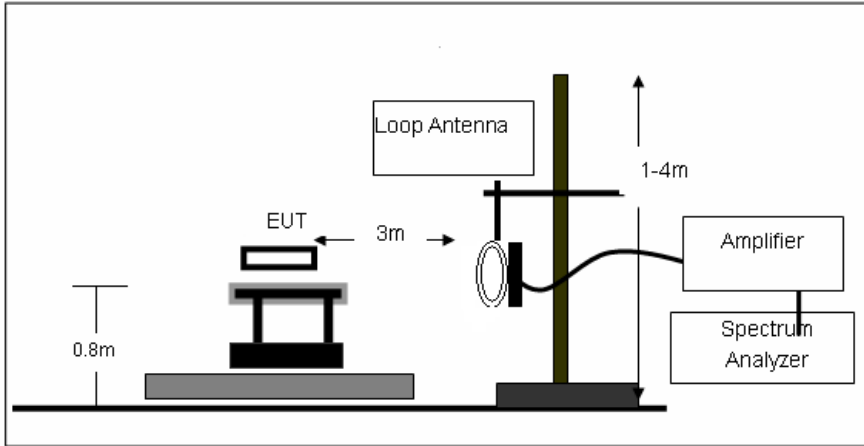

(2) Radiated Emission Test-Up Frequency 30MHz~1GHz

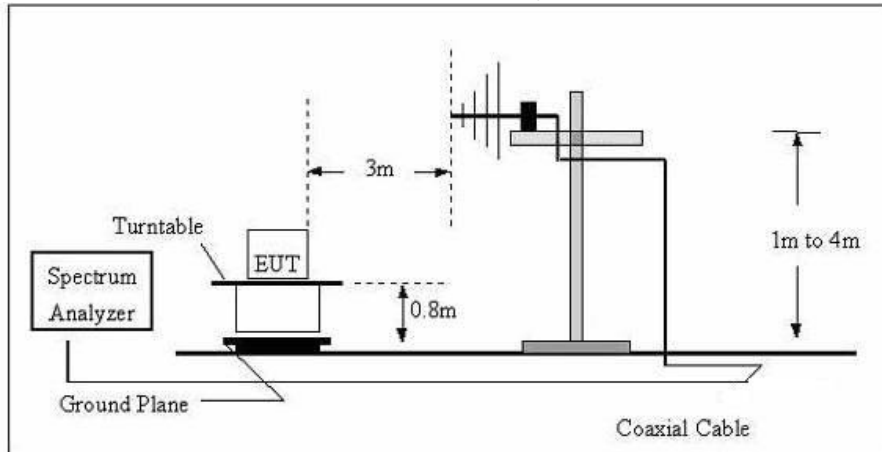

(3) Radiated Emission Test-Up Frequency Above 1GHz

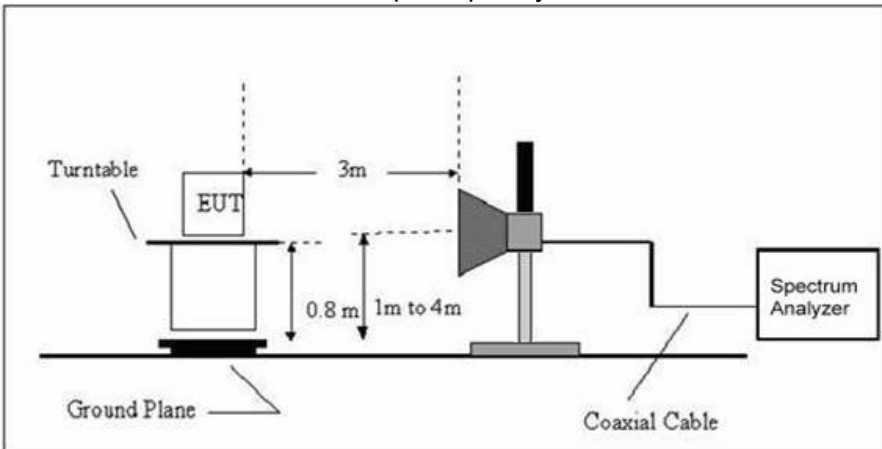

#### 4.2 Limits

For unintentional device, according to § 15.109(a), except for Class A digital devices, the field strength of radiated emissions from unintentional radiators at a distance of 3 meters shall not exceed the following values:

Frequency (MHz)	Distance (Meters)	Radiated (dB $\mu$ V/m)	Radiated ( $\mu$ V/m)
30-88	3	40	100
88-216	3	43.5	150
216-960	3	46	200
Above 960	3	54	500

For intentional device, according to § 15.209(a), the general requirement of field strength of radiated emissions from intentional radiators at a distance of 3 meters shall not exceed the above table.

#### 4.3 Test Procedure

1. The EUT is placed on a turntable, which is 0.8m above ground plane.
2. The turntable shall be rotated for 360 degrees to determine the position of maximum emission level.
3. EUT is set 3m away from the receiving antenna, which is varied from 1m to 4m to find out the highest emissions.
4. Maximum procedure was performed on the six highest emissions to ensure EUT compliance.
5. And also, each emission was to be maximized by changing the polarization of receiving antenna both horizontal and vertical.
6. Repeat above procedures until the measurements for all frequencies are complete.
7. Based on the Frequency Generator in the device include 26MHz. The test frequency range from 9KHz to 25GHz per FCC PART 15.33(a).

Note:

Three axes are chosen for pretest, the Y axis is the worst mode for final test.

For battery operated equipment, the equipment tests shall be performed using a new battery.

4.4 Test Result

PASS

All the test modes completed for test. The worst case of Radiated Emission is playing music; the test data of this mode was reported.

Below 1GHz Test Results:

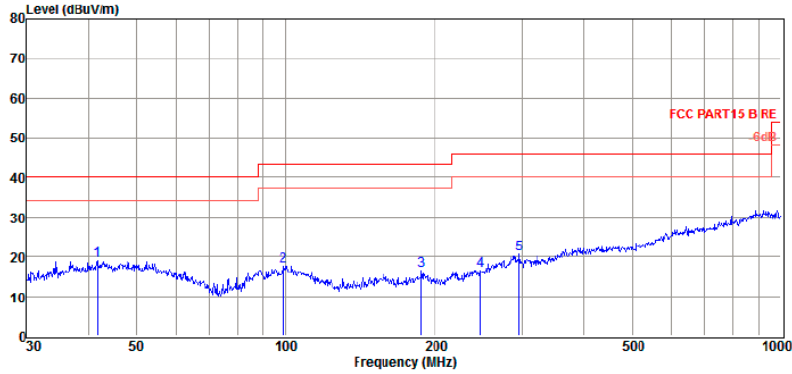

Item (Mark)	Freq (MHz)	Read Level (dBuV)	Antenna Factor (dB/m)	Cable Loss (dB)	Result Level (dBuV/m)	Limit Line (dBuV/m)	Over Limit (dB)	Detector	Polarization
1	41.57	3.87	14.00	1.01	18.88	40.00	-21.12	Peak	VERTICAL
2	98.83	3.99	12.25	1.49	17.73	43.50	-25.77	Peak	VERTICAL
3	187.75	3.69	10.57	2.11	16.37	43.50	-27.13	Peak	VERTICAL
4	246.82	2.60	11.50	2.38	16.48	46.00	-29.52	Peak	VERTICAL
5	296.18	4.19	13.83	2.69	20.71	46.00	-25.29	Peak	VERTICAL

Note: 1. Result Level = Read Level + Antenna Factor + Cable loss.  
 2. If Peak Result complies with QP limit, QP Result is deemed to comply with QP limit.  
 3. Test setup: RBW: 120 kHz, VBW: 300 kHz, Sweep time: auto.

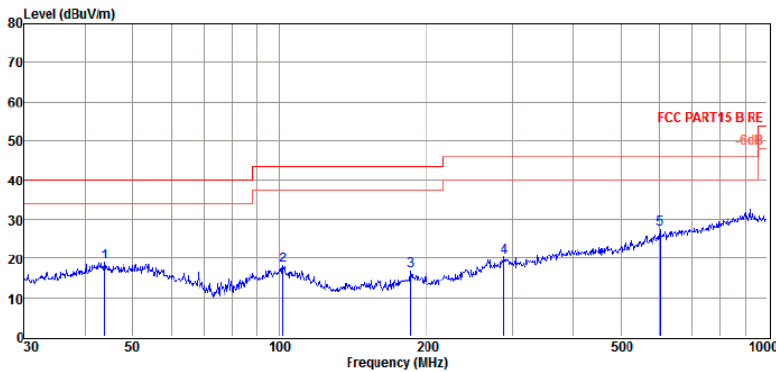

Item (Mark)	Freq (MHz)	Read Level (dBuV)	Antenna Factor (dB/m)	Cable Loss (dB)	Result Level (dBuV/m)	Limit Line (dBuV/m)	Over Limit (dB)	Detector	Polarization
1	43.81	3.07	14.90	1.03	19.00	40.00	-21.00	Peak	HORIZONTAL
2	101.64	4.16	12.50	1.50	18.16	43.50	-25.34	Peak	HORIZONTAL
3	185.79	3.99	10.57	2.10	16.66	43.50	-26.84	Peak	HORIZONTAL
4	289.00	3.40	14.25	2.67	20.32	46.00	-25.68	Peak	HORIZONTAL
5	603.34	5.39	18.21	3.98	27.58	46.00	-18.42	Peak	HORIZONTAL

Note: 1. Result Level = Read Level + Antenna Factor + Cable loss.  
 2. If Peak Result complies with QP limit, QP Result is deemed to comply with QP limit.  
 3. Test setup: RBW: 120 kHz, VBW: 300 kHz, Sweep time: auto.

Remark:

- (1) Measuring frequencies from 9 KHz to the 1 GHz, Radiated emission test from 9KHz to 30MHz was verified, and no any emission was found except system noise floor.
- (2) \* denotes emission frequency which appearing within the Restricted Bands specified in provision of 15.205, then the general radiated emission limits in 15.209 apply.
- (3) The IF bandwidth of EMI Test Receiver between 30MHz to 1GHz was 120KHz, 1 MHz for measuring above 1 GHz, below 30MHz was 10KHz.

Above 1 GHz Test Results:  
Horizontal  
CH Low (2402MHz)

	Freq	Preamp Factor	Read Level	Cable Loss	Antenna Factor	Level	Limit Line	Over Limit	Remark
	MHz	dB	dBuV	dB	dB/m	dBuV/m	dBuV/m	dB	
1	2402.00	26.32	79.68	7.34	28.72	89.42	94.00	-4.58	Average
2	2402.00	26.32	91.60	7.34	28.72	101.34	114.00	-12.66	Peak
3	4804.00	27.49	31.78	11.96	32.94	49.19	74.00	-24.81	Peak
4	6831.00	27.87	16.60	16.60	36.75	42.08	74.00	-31.92	Peak
5	9483.00	28.59	15.98	16.92	37.98	42.29	74.00	-31.71	Peak
6	13087.00	29.22	12.11	18.32	41.10	42.31	74.00	-31.69	Peak

Vertical  
CH Low (2402MHz)

	Freq	Preamp Factor	Read Level	Cable Loss	Antenna Factor	Level	Limit Line	Over Limit	Remark
	MHz	dB	dBuV	dB	dB/m	dBuV/m	dBuV/m	dB	
1	2402.00	26.32	79.45	7.34	28.72	89.19	94.00	-4.81	Average
2	2402.00	26.32	91.59	7.34	28.72	101.33	114.00	-12.67	Peak
3	4804.00	27.49	31.71	11.96	32.94	49.12	74.00	-24.88	Peak
4	6712.00	27.84	15.64	16.60	36.44	40.84	74.00	-33.16	Peak
5	9619.00	28.65	16.27	16.93	38.10	42.65	74.00	-31.35	Peak
6	12985.00	29.20	14.84	18.20	40.66	44.50	74.00	-29.50	Peak

Horizontal  
CH Middle (2441MHz)

	Freq	Preamp Factor	Read Level	Cable Loss	Antenna Factor	Level	Limit Line	Over Limit	Remark
	MHz	dB	dBuV	dB	dB/m	dBuV/m	dBuV/m	dB	
1	2441.00	26.33	79.47	7.48	28.76	89.38	94.00	-4.62	Average
2	2441.00	26.33	91.27	7.48	28.76	101.18	114.00	-12.82	Peak
3	4882.00	27.53	31.49	12.14	33.11	49.21	74.00	-24.79	Peak
4	7137.00	27.93	15.91	16.60	37.26	41.84	74.00	-32.16	Peak
5	10231.00	28.82	18.32	17.01	38.77	45.28	74.00	-28.72	Peak
6	13376.00	29.27	13.48	18.65	42.44	45.30	74.00	-28.70	Peak

Vertical  
CH Middle (2441MHz)

	Preamp Freq	Factor dB	Read Level dBuV	Cable Loss dB	Antenna Factor dB/m	Level dBuV/m	Limit Line dBuV/m	Over Limit dB	Remark
1	2441.00	26.33	79.52	7.48	28.76	89.43	94.00	-4.57	Average
2	2441.00	26.33	91.66	7.48	28.76	101.57	114.00	-12.43	Peak
3	4882.00	27.53	31.57	12.14	33.11	49.29	74.00	-24.71	Peak
4	7341.00	27.97	16.69	16.62	37.34	42.68	74.00	-31.32	Peak
5	11370.00	28.94	15.14	17.24	39.79	43.23	74.00	-30.77	Peak
6	13546.00	29.31	10.25	18.83	43.05	42.82	74.00	-31.18	Peak

Horizontal  
CH High (2480MHz)

	Preamp Freq	Factor dB	Read Level dBuV	Cable Loss dB	Antenna Factor dB/m	Level dBuV/m	Limit Line dBuV/m	Over Limit dB	Remark
1	2480.00	26.34	79.62	7.57	28.79	89.64	94.00	-4.36	Average
2	2480.00	26.34	91.45	7.57	28.79	101.47	114.00	-12.53	Peak
3	4960.00	27.58	31.11	12.36	33.32	49.21	74.00	-24.79	Peak
4	7103.00	27.92	15.71	16.60	37.24	41.63	74.00	-32.37	Peak
5	11455.00	28.95	12.90	17.26	39.86	41.07	74.00	-32.93	Peak
6	14770.00	29.52	12.99	19.85	39.48	42.80	74.00	-31.20	Peak

Vertical  
CH High (2480MHz)

	Preamp Freq	Factor dB	Read Level dBuV	Cable Loss dB	Antenna Factor dB/m	Level dBuV/m	Limit Line dBuV/m	Over Limit dB	Remark
1	2480.00	26.34	79.30	7.57	28.79	89.32	94.00	-4.68	Average
2	2480.00	26.34	91.59	7.57	28.79	101.61	114.00	-12.39	Peak
3	4960.00	27.58	31.22	12.36	33.32	49.32	74.00	-24.68	Peak
4	7018.00	27.90	17.62	16.60	37.21	43.53	74.00	-30.47	Peak
5	10129.00	28.81	16.07	16.99	38.61	42.86	74.00	-31.14	Peak
6	13818.00	29.36	10.96	19.14	43.32	44.06	74.00	-29.94	Peak

## Remark:

- (1) Measuring frequencies from 1 GHz to the 25 GHz.
- (2) "F" denotes fundamental frequency; "H" denotes spurious frequency. "E" denotes band edge frequency.
- (3) \* denotes emission frequency which appearing within the Restricted Bands specified in provision of 15.205, then the general radiated emission limits in 15.209 apply.
- (4) Data of measurement within this frequency range shown "---" in the table above means the reading of emissions are attenuated more than 20dB below the permissible limits or the field strength is too small to be measured.
- (5) The IF bandwidth of EMI Test Receiver between 30MHz to 1GHz was 120KHz, 1 MHz for measuring above 1 GHz, below 30MHz was 10KHz.
- (6) When the test results of Peak Detected below the limits of Average Detected, the Average Detected is not need completed. For example: Top Channel at Fundamental 73.16dBuV/m(PK Value) <93.98(AV Limit), at harmonic 53.20 dBuV/m(PK Value) <54 dBuV/m(AV Limit), the Average Detected not need to completed.



## 5 BAND EDGE

### 5.1 Block Diagram of Test Setup

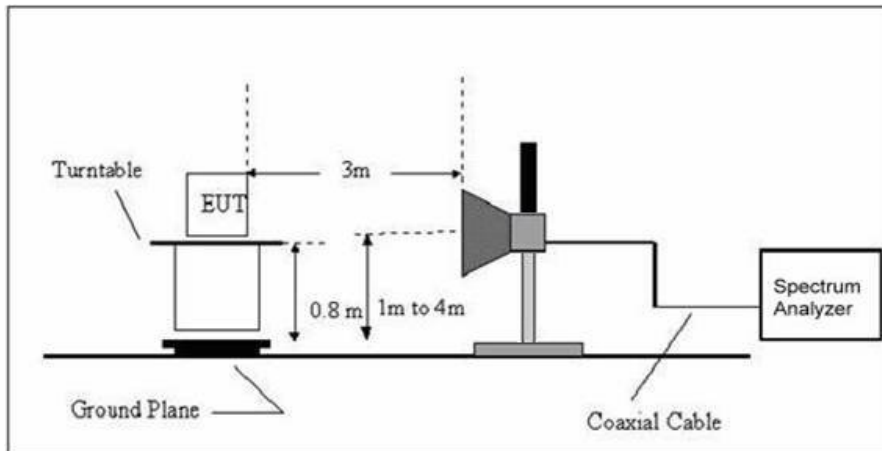

### 5.2 Limits

FCC PART 15.249(d) Emissions radiated outside of the specified frequency bands, except for harmonics, shall be attenuated by at least 50 dB below the level of the fundamental or to the general radiated emission limits in §15.209, whichever is the lesser attenuation.

### 5.3 Test Procedure

The band edge compliance of RF radiated emission should be measured by following the guidance in ANSI C63.4 with respect to maximizing the emission by rotating the EUT, measuring the emission while the EUT is situated in three orthogonal planes (if appropriate), adjusting the measurement antenna height and polarization etc. Set RBW to 100KHz and VBM to 300KHz to measure the peak field strength and set RBW to 1MHz and VBW to 10Hz to measure the average radiated field strength. The conducted RF band edge was measured by using a spectrum analyzer. Set span wide enough to capture the highest in-band emission and the emission at the band edge. Set RBW to 100 KHz and VBM to 300 KHz, to measure the conducted peak band edge.

### 5.4 Test Result

PASS

CH: Low 2402MHz  
 Antenna polarization: H

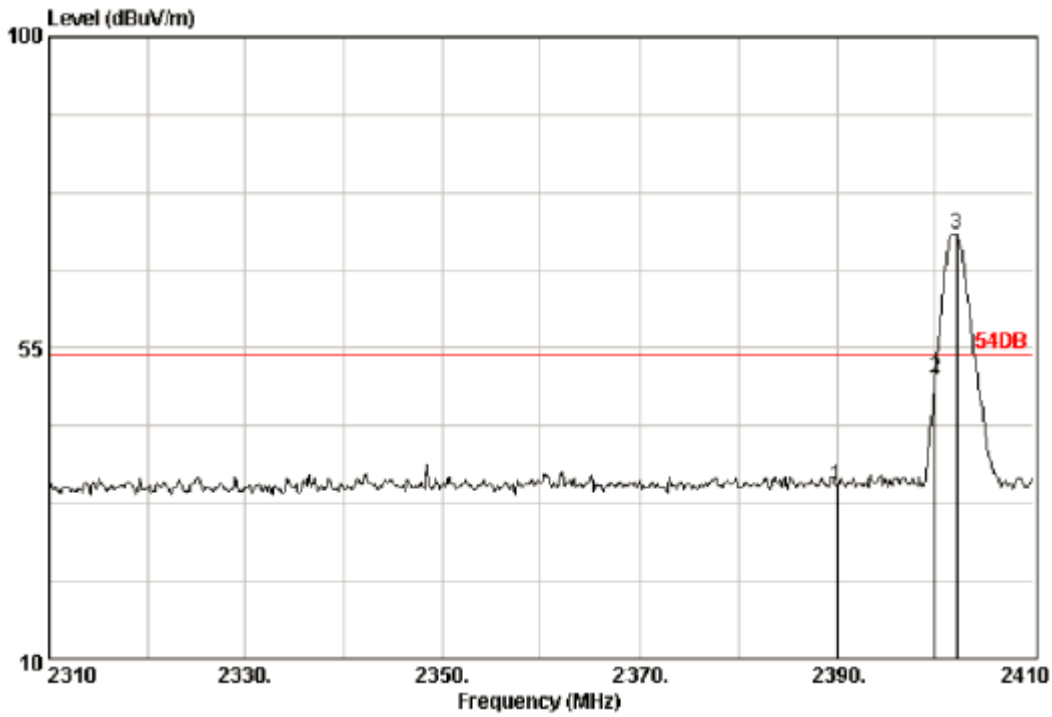

	Freq. (MHz)	Ant. Factor (dB)	Cable Loss (dB)	Reading (dBuV)	Emission Level (dBuV/m)	Limits (dBuV/m)	Margin (dB)	Remark
1	2390.00	28.78	4.61	37.10	35.13	54.00	18.87	Peak
2	2400.00	28.78	4.61	52.54	50.57	54.00	3.43	Peak
3	2402.20	28.78	4.61	73.51	71.54	54.00	-17.54	Peak

CH: Low 2402MHz  
 Antenna polarization: V

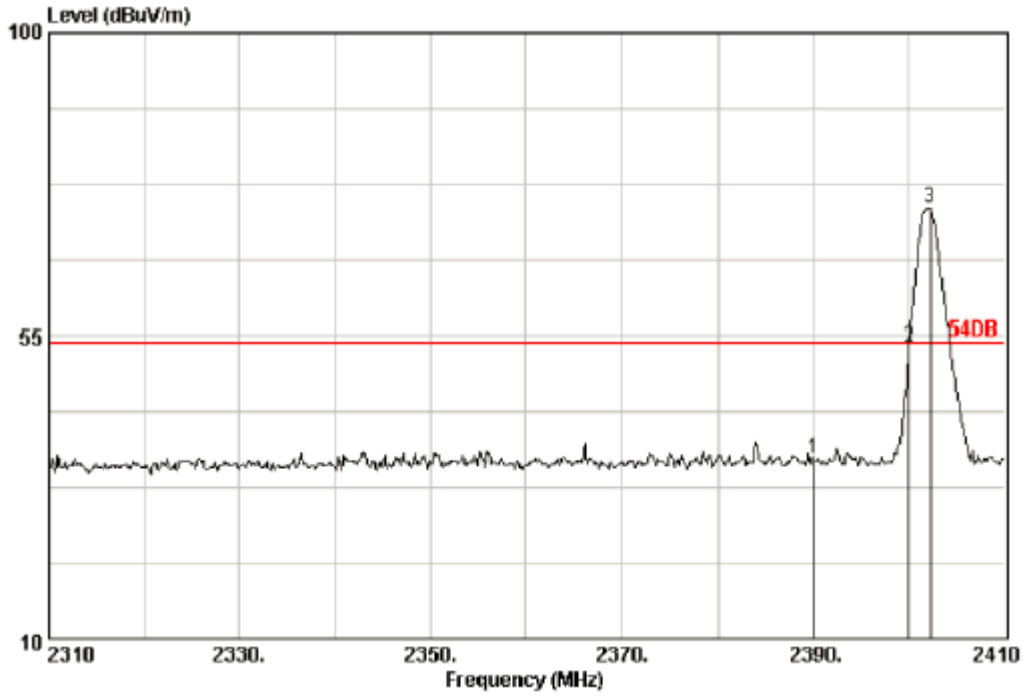

	Freq. (MHz)	Ant. Factor (dB)	Cable Loss (dB)	Reading (dBuV)	Emission Level (dBuV/m)	Limits (dBuV/m)	Margin (dB)	Remark
1	2390.00	28.78	4.61	38.90	36.93	54.00	17.07	Peak
2	2400.00	28.78	4.61	55.46	53.49	54.00	0.51	Peak
3	2402.20	28.78	4.61	75.89	73.92	54.00	-19.92	Peak

CH: High 2480MHz  
 Antenna polarization: H

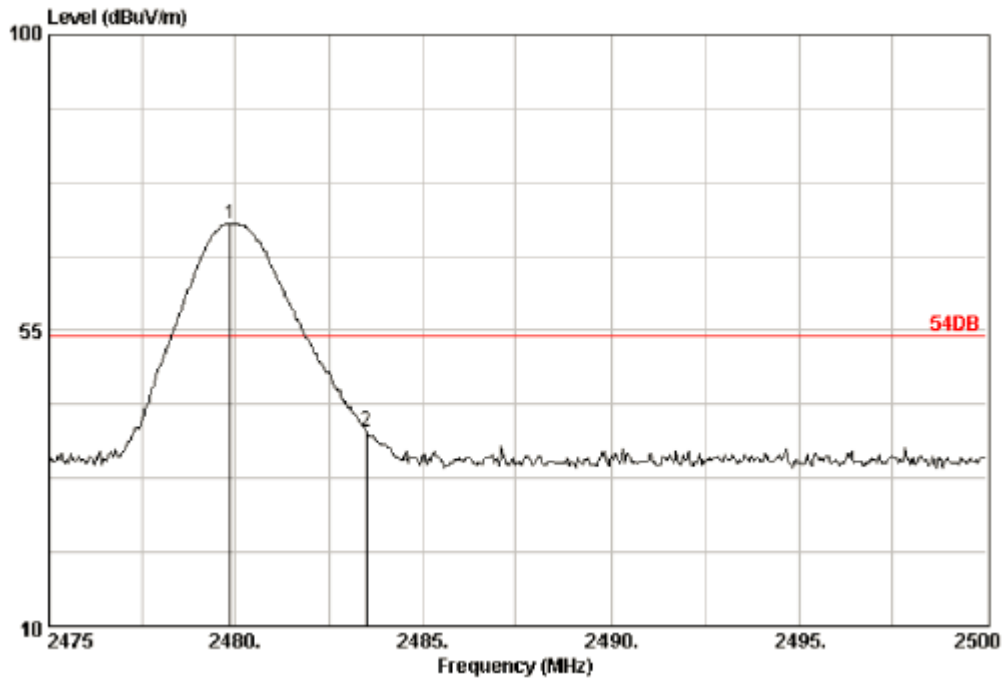

	Freq. (MHz)	Ant. Factor (dB)	Cable Loss (dB)	Reading (dBuV)	Emission			Remark
					Level (dBuV/m)	Limits (dBuV/m)	Margin (dB)	
1	2479.85	28.93	4.70	72.97	71.22	54.00	-17.22	Peak
2	2483.50	28.93	4.70	41.36	39.61	54.00	14.39	Peak

CH: High 2480MHz  
 Antenna polarization: V

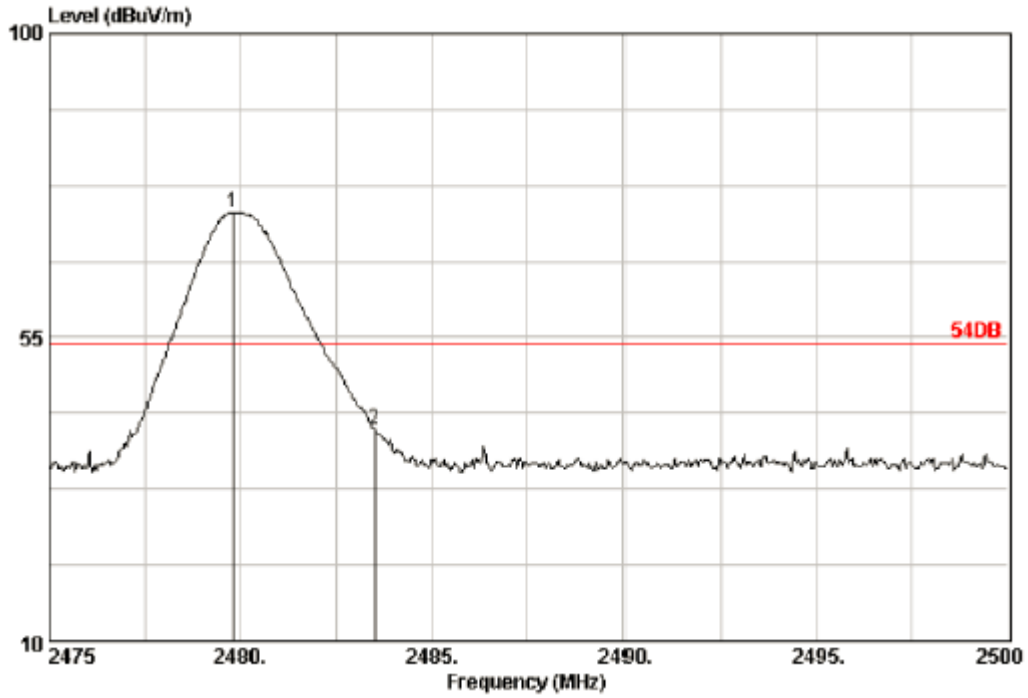

	Freq. (MHz)	Ant. Factor (dB)	Cable Loss (dB)	Reading (dBuV)	Emission Level (dBuV/m)	Limits (dBuV/m)	Margin (dB)	Remark
1	2479.80	28.93	4.70	75.18	73.43	54.00	-19.43	Peak
2	2483.50	28.93	4.70	43.20	41.45	54.00	12.55	Peak

**6 OCCUPIED BANDWIDTH MEASUREMENT**

**6.1 Block Diagram of Test Setup**

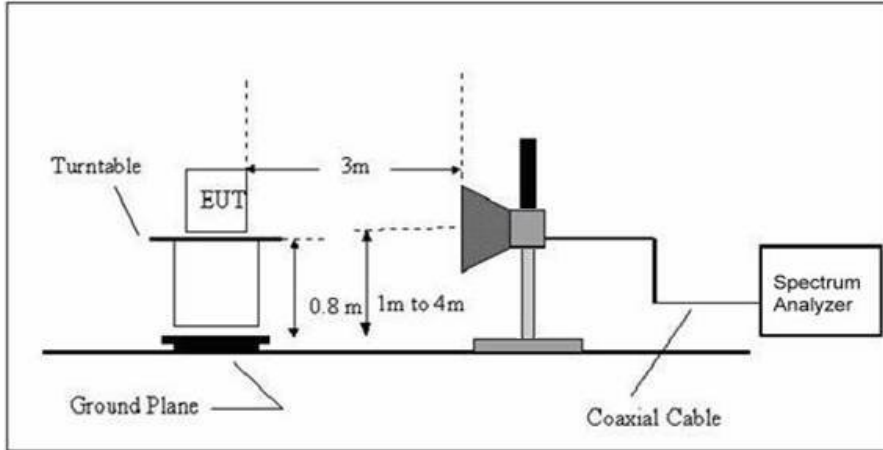

**6.3 Test Procedure**

1. The EUT was placed on a turn table which is 0.8m above ground plane.
2. Set EUT as normal operation.
3. Based on FCC Part15 C Section 15.239(a): RBW= 10KHz. VBW= 30 KHz, Span=1MHz.
4. The useful radiated emission from the EUT was detected by the spectrum analyser with peak detector.

**6.3 Test Result**

**PASS**

Channel Frequency (MHz)	20dB Bandwidth (MHz)	Result
2402	0.9342	Pass
2441	0.9348	Pass
2480	0.9353	Pass

CH: 2402MHz

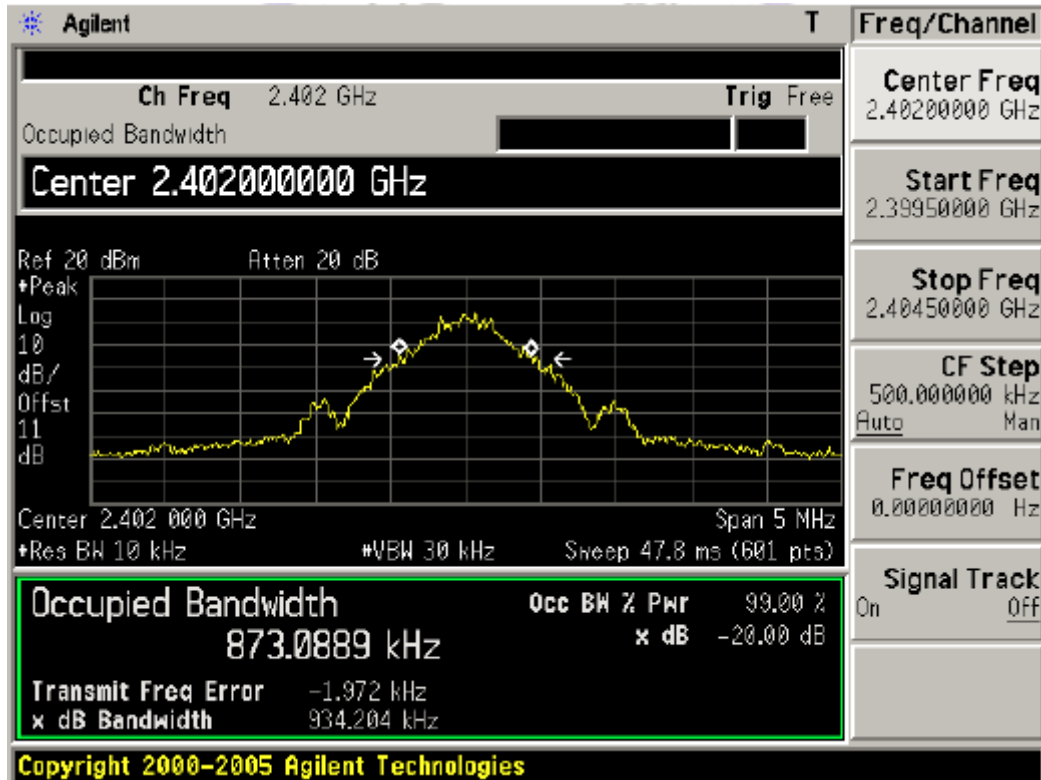

CH: 2441MHz

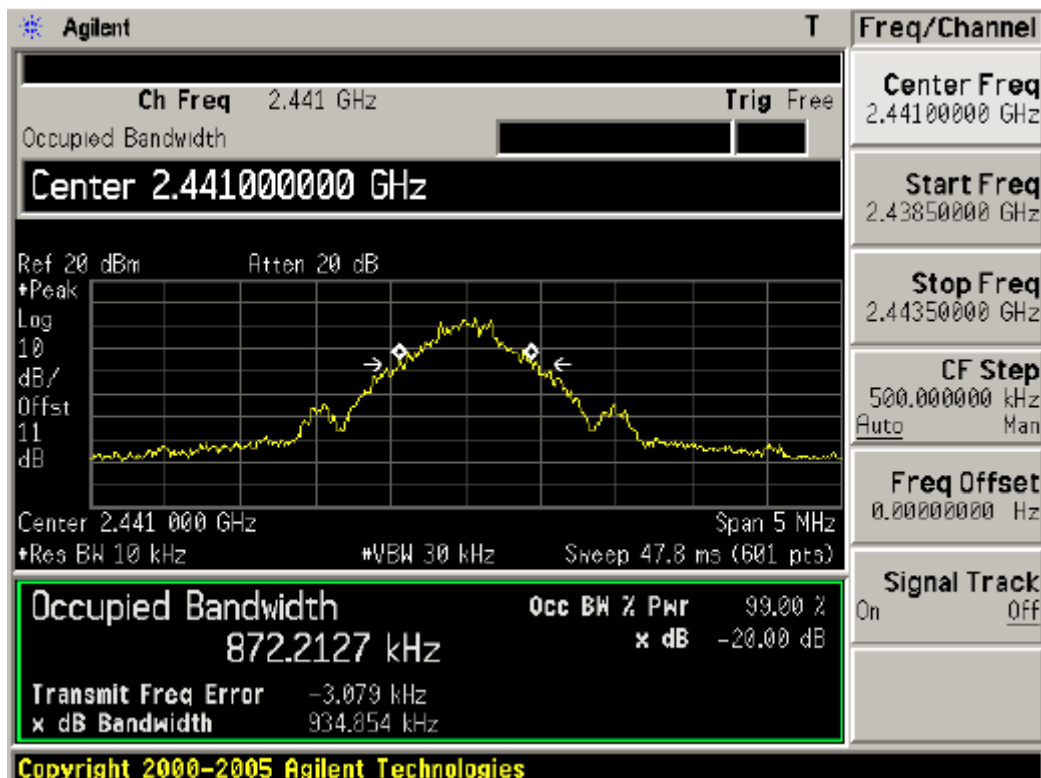

CH: 2480MHz

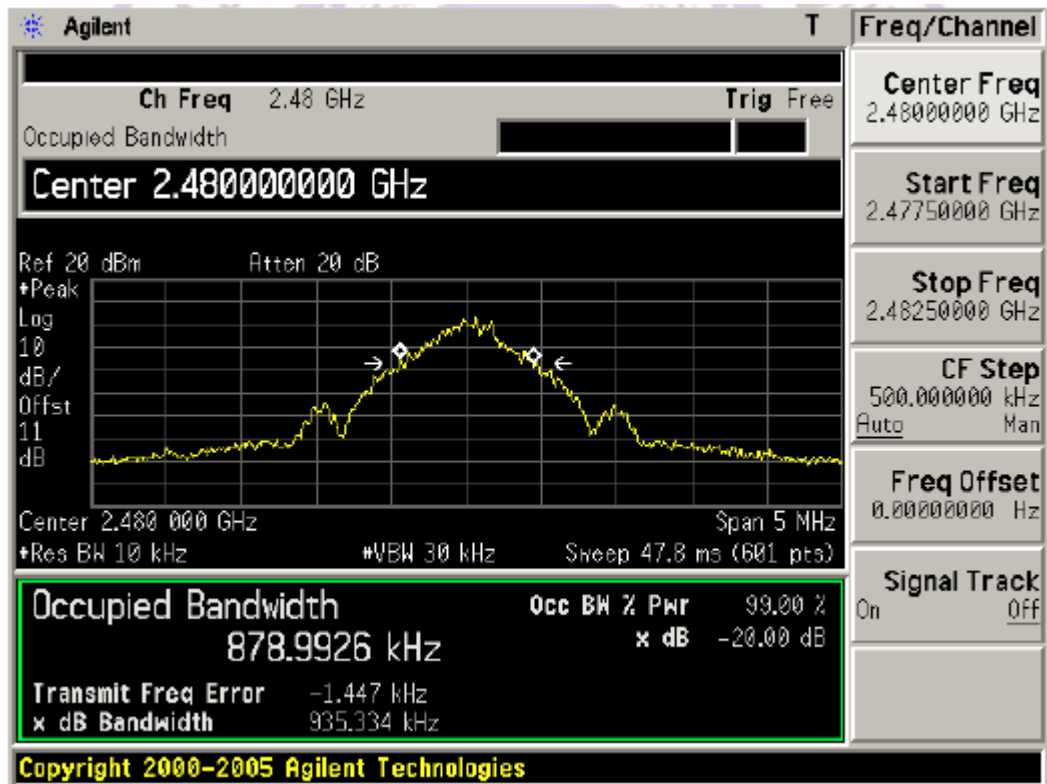



## 7 Antenna Requirement

According to Section 15.203, an intentional radiator shall be designed to ensure that no antenna other than that furnished by the responsible party shall be used with the device. Antenna is fixed by enclosure, can not be changed except take apart the product.

Antenna

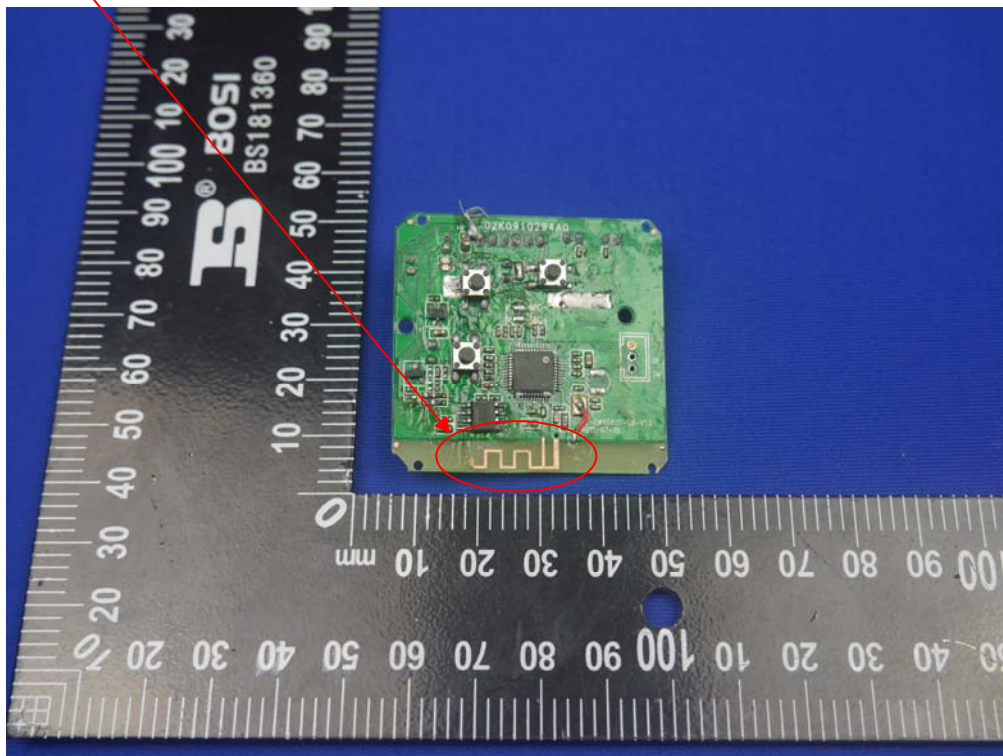

8 Photograph of Test

8.1 Radiated Emission

