



FCC PART 15 SUBPART C TEST REPORT

FCC PART 15.247

Report Reference No.....: GTSR15090061-WLAN

FCC ID..... : 2AF9M-MTP28X

Compiled by
 (position+printed name+signature)..: File administrators Jimmy Wang

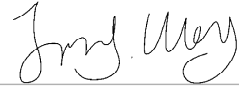

Supervised by
 (position+printed name+signature)..: Test Engineer Peter Xiao



Approved by
 (position+printed name+signature)..: Manager Sam Wang

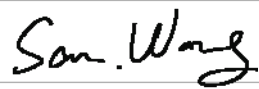

Date of issue.....: Oct. 22, 2015

Representative Laboratory Name .: Shenzhen Global Test Service Co.,Ltd.

Address: 1F, Building No. 13A, Zhonghaixin Science and Technology City, No.12,6 Road, Ganli Industrial Park, Buji Street, Longgang District, Shenzhen, Guangdong

Testing Laboratory Name: Shenzhen CTL Testing Technology Co., Ltd

Address: 1/F.-A, Baisha Technology Park, No.3011, Shahexi Road, Nanshan District, Shenzhen, Guangdong, China

Applicant's name.....: Shenzhen Mteche technology co.,limited

Address: 307 Room, YinHai Buliding, 75# ZhenHua Road, Futian, Shenzhen, GuangDong, China

Test specification

Standard.....: **FCC Part 15.247: Operation within the bands 902-928 MHz, 2400-2483.5 MHz and 5725-5850 MHz**

TRF Originator.....: Shenzhen Global Test Service Co.,Ltd.

Master TRF.....: Dated 2014-12

Shenzhen Global Test Service Co.,Ltd. All rights reserved.

This publication may be reproduced in whole or in part for non-commercial purposes as long as the Shenzhen Global Test Service Co.,Ltd. is acknowledged as copyright owner and source of the material. Shenzhen Global Test Service Co.,Ltd. takes no responsibility for and will not assume liability for damages resulting from the reader's interpretation of the reproduced material due to its placement and context.

Test item description Tablet PC

Trade Mark: /

Manufacturer: **Shenzhen Mteche technology co.,limited**

Model/Type reference.....: MTP289

Listed Models: MTP28X("X" is number 3-9)

Operation Frequency.....: From 2412MHz to 2472MHz

EUT Type: Production Unit

Rating: DC 5.0V

Result.....: **PASS**

TEST REPORT

Test Report No. :	GTSR15090061-WLAN	Oct. 22, 2015
		Date of issue

Equipment under Test : Tablet PC

Model /Type : MTP289

Listed Models : MTP28X("X" is number 3-9)

Applicant : **Shenzhen Mteche technology co.,limited**

Address : 307 Room, YinHai Buliding, 75# ZhenHua Road, Futian, Shenzhen, GuangDong, China

Manufacturer : **Shenzhen Mteche technology co.,limited**

Address : 307 Room, YinHai Buliding, 75# ZhenHua Road, Futian, Shenzhen, GuangDong, China

Test Result:	PASS
---------------------	-------------

The test report merely corresponds to the test sample.
It is not permitted to copy extracts of these test result without the written permission of the test laboratory.

Contents

1.	<u>TEST STANDARDS.....</u>	4
2.	<u>SUMMARY</u>	5
2.1.	General Remarks	5
2.2.	Product Description	5
2.3.	Equipment Under Test	5
2.4.	Short description of the Equipment under Test (EUT)	5
2.5.	EUT operation mode	5
2.6.	Block Diagram of Test Setup	6
2.7.	Related Submittal(s) / Grant (s)	6
2.8.	Modifications	6
2.9.	NOTE	6
3.	<u>TEST ENVIRONMENT.....</u>	7
3.1.	Address of the test laboratory	7
3.2.	Test Facility	7
3.3.	Environmental conditions	7
3.4.	Test Description	7
3.5.	Statement of the measurement uncertainty	8
3.6.	Equipments Used during the Test	9
4.	<u>TEST CONDITIONS AND RESULTS.....</u>	10
4.1.	AC Power Conducted Emission	10
4.2.	Radiated Emission.....	13
4.3.	Maximum Peak Output Power.....	21
4.4.	Power Spectral Density	22
4.5.	6dB Bandwidth	25
4.6.	Band Edge Compliance of RF Emission	28
4.7.	Spurious RF Conducted Emission	33
4.8.	Antenna Requirement.....	46
5.	<u>TEST SETUP PHOTOS OF THE EUT</u>	47
6.	<u>EXTERNAL AND INTERNAL PHOTOS OF THE EUT</u>	48

1. TEST STANDARDS

The tests were performed according to following standards:

[FCC Rules Part 15.247](#): Frequency Hopping, Direct Spread Spectrum and Hybrid Systems that are in operation within the bands of 902-928 MHz, 2400-2483.5 MHz, and 5725-5850 MHz.

[ANSI C63.10-2009](#): American National Standard for Testing Unlicensed Wireless Devices

[KDB558074 D01 V03r02](#): Guidance for Performing Compliance Measurements on Digital Transmission Systems (DTS) Operating Under §15.247

2. SUMMARY

2.1. General Remarks

Date of receipt of test sample	:	Sep. 28, 2015
Testing commenced on	:	Sep. 28, 2015
Testing concluded on	:	Oct. 22, 2015

2.2. Product Description

The **Shenzhen Mteche technology co.,limited**'s Model: MTP289 or the "EUT" as referred to in this report; more general information as follows, for more details, refer to the user's manual of the EUT.

Name of EUT	Tablet PC
Model Number	MTP289
Listed Models	MTP28X("X" is number 3-9)
FCC ID	2AF9M-MTP28X
Antenna Type	Internal
WLAN FCC Operation frequency	IEEE 802.11b: 2412MHz—2462MHz IEEE 802.11g: 2412MHz—2462MHz IEEE 802.11n HT20: 2412MHz—2462MHz IEEE 802.11n HT40: 2422MHz—2452MHz
WLAN Modulation	IEEE 802.11b: DSSS(CCK,DQPSK,DBPSK) IEEE 802.11g: OFDM(64QAM, 16QAM, QPSK, BPSK) IEEE 802.11n HT20: OFDM (64QAM, 16QAM, QPSK,BPSK) IEEE 802.11n HT40: OFDM (64QAM, 16QAM, QPSK,BPSK)
WLAN	Supported 802.11b/802.11g/802.11n HT20/802.11n HT40
Remark:All models are the same except for name.	

2.3. Equipment Under Test

Power supply system utilised

Power supply voltage	:	<input type="radio"/> 230V / 50 Hz	<input type="radio"/> 120V / 60Hz
		<input type="radio"/> 12 V DC	<input type="radio"/> 24 V DC
		<input checked="" type="radio"/> Other (specified in blank below)	

DC 5.0V

2.4. Short description of the Equipment under Test (EUT)

This is a Tablet PC.

For more details, refer to the user's manual of the EUT.

2.5. EUT operation mode

The application provider specific test software to control sample in continuous TX and RX (Duty Cycle >98%) for testing meet KDB558074 test requirement.

IEEE 802.11b/g/n: Thirteen channels are provided to the EUT.

Channel	Frequency(MHz)	Channel	Frequency(MHz)
1	2412	8	2447
2	2417	9	2452
3	2422	10	2457
4	2427	11	2462
5	2432	12	2467
6	2437	13	2472
7	2442		

2.6. Block Diagram of Test Setup

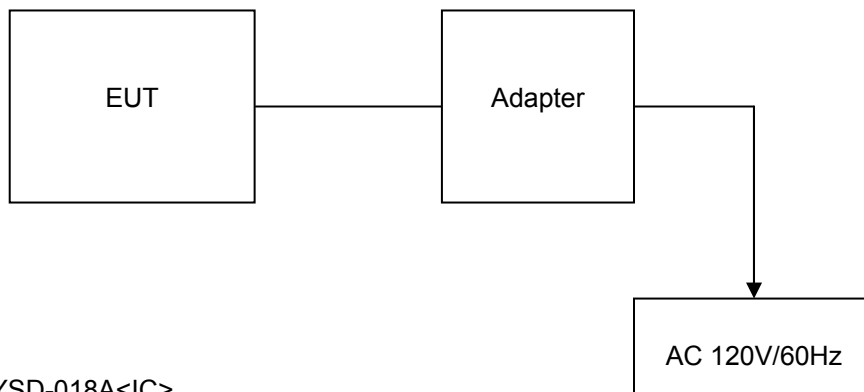

Adapter:

Model: YSD-018A<IC>
 Input: 100-240V~50/60Hz 0.25A
 Output: 5.0V DC 2A
 Power Cable: 120cm
 ◇ Shielded ◆ Unshielded

2.7. Related Submittal(s) / Grant (s)

This submittal(s) (test report) is intended for **FCC ID: 2AF9M-MTP28X** filing to comply with Section 15.247 of the FCC Part 15, Subpart C Rules.

2.8. Modifications

No modifications were implemented to meet testing criteria.

2.9. NOTE

1. The EUT is a Tablet PC with WLAN function, The functions of the EUT listed as below:

	Test Standards	Reference Report
WLAN	FCC Part 15 Subpart C	GTSR15090061-WLAN
MPE	FCC Per 47 CFR 2.1093(d)	GTSR15090061-MPE

2. The frequency bands used in this EUT are listed as follows:

Frequency Band(MHz)	2400-2483.5	5150-5350	5470-5725	5725-5850
802.11b	√	—	—	—
802.11g	√	—	—	—
802.11n HT20	√	—	—	—
802.11n HT40	√	—	—	—

3. The EUT incorporates a SISO function, Physically, the EUT provides one completed transmitter and one completed receiver.

Modulation Mode	TX Function
802.11b	1TX
802.11g	1TX
802.11n HT20	1TX
802.11n HT40	1TX

3. TEST ENVIRONMENT

3.1. Address of the test laboratory

Shenzhen CTL Testing Technology Co., Ltd

1/F.-A, Baisha Technology Park, No.3011, Shahexi Road, Nanshan District, Shenzhen, Guangdong, China

3.2. Test Facility

The test facility is recognized, certified, or accredited by the following organizations:

FCC-Registration No.: 964637

Shenzhen Global Test Service Co.,Ltd EMC Laboratory has been registered and fully described in a report filed with the (FCC) Federal Communications Commission. The acceptance letter from the FCC is maintained in our files. Registration 964637, Jul 24, 2015.

3.3. Environmental conditions

During the measurement the environmental conditions were within the listed ranges:

Temperature:	15-35 ° C
Humidity:	30-60 %
Atmospheric pressure:	950-1050mbar

3.4. Test Description

Test Specification clause	Test case	Test Mode	Test Channel	Recorded In Report	Pass	Fail	NA	NP	Remark	
§15.247(b)(4)	Antenna gain	802.11b	<input checked="" type="checkbox"/> Lowest <input checked="" type="checkbox"/> Middle <input checked="" type="checkbox"/> Highest	802.11b	<input checked="" type="checkbox"/> Lowest <input checked="" type="checkbox"/> Middle <input checked="" type="checkbox"/> Highest	<input checked="" type="checkbox"/>	<input type="checkbox"/>	<input type="checkbox"/>	<input type="checkbox"/>	complies
§15.247(e)	Power spectral density	802.11b 802.11g 802.11n HT20 802.11n HT40	<input checked="" type="checkbox"/> Lowest <input checked="" type="checkbox"/> Middle <input checked="" type="checkbox"/> Highest	802.11b 802.11g 802.11n HT20 802.11n HT40	<input checked="" type="checkbox"/> Lowest <input checked="" type="checkbox"/> Middle <input checked="" type="checkbox"/> Highest	<input checked="" type="checkbox"/>	<input type="checkbox"/>	<input type="checkbox"/>	<input type="checkbox"/>	complies
§15.247(a)(1)	Spectrum bandwidth – 6 dB bandwidth	802.11b 802.11g 802.11n HT20 802.11n HT40	<input checked="" type="checkbox"/> Lowest <input checked="" type="checkbox"/> Middle <input checked="" type="checkbox"/> Highest	802.11b 802.11g 802.11n HT20 802.11n HT40	<input checked="" type="checkbox"/> Lowest <input checked="" type="checkbox"/> Middle <input checked="" type="checkbox"/> Highest	<input checked="" type="checkbox"/> <input checked="" type="checkbox"/>	<input type="checkbox"/>	<input type="checkbox"/>	<input type="checkbox"/>	complies
§15.247(b)(1)	Maximum output power	802.11b 802.11g 802.11n HT20 802.11n HT40	<input checked="" type="checkbox"/> Lowest <input checked="" type="checkbox"/> Middle <input checked="" type="checkbox"/> Highest	802.11b 802.11g 802.11n HT20 802.11n HT40	<input checked="" type="checkbox"/> Lowest <input checked="" type="checkbox"/> Middle <input checked="" type="checkbox"/> Highest	<input checked="" type="checkbox"/> <input checked="" type="checkbox"/> <input checked="" type="checkbox"/>	<input type="checkbox"/>	<input type="checkbox"/>	<input type="checkbox"/>	complies
§15.247(d)	Band edge compliance conducted	802.11b 802.11g 802.11n HT20 802.11n HT40	<input checked="" type="checkbox"/> Lowest <input checked="" type="checkbox"/> Highest	802.11b 802.11g 802.11n HT20 802.11n HT40	<input checked="" type="checkbox"/> Lowest <input checked="" type="checkbox"/> Highest	<input checked="" type="checkbox"/> <input checked="" type="checkbox"/>	<input type="checkbox"/>	<input type="checkbox"/>	<input type="checkbox"/>	complies
§15.205	Band edge compliance radiated	802.11b 802.11g 802.11n HT20 802.11n HT40	<input checked="" type="checkbox"/> Lowest <input checked="" type="checkbox"/> Highest	802.11b 802.11g 802.11n HT20 802.11n HT40	<input checked="" type="checkbox"/> Lowest <input checked="" type="checkbox"/> Highest	<input checked="" type="checkbox"/>	<input type="checkbox"/>	<input type="checkbox"/>	<input type="checkbox"/>	complies
§15.247(d)	TX spurious emissions conducted	802.11b 802.11g 802.11n HT20 802.11n HT40	<input checked="" type="checkbox"/> Lowest <input checked="" type="checkbox"/> Middle <input checked="" type="checkbox"/> Highest	802.11b 802.11g 802.11n HT20 802.11n HT40	<input checked="" type="checkbox"/> Lowest <input checked="" type="checkbox"/> Middle <input checked="" type="checkbox"/> Highest	<input checked="" type="checkbox"/> <input checked="" type="checkbox"/>	<input type="checkbox"/>	<input type="checkbox"/>	<input type="checkbox"/>	complies
§15.247(d)	TX spurious emissions radiated	802.11b 802.11g 802.11n HT20 802.11n HT40	<input checked="" type="checkbox"/> Lowest <input checked="" type="checkbox"/> Middle <input checked="" type="checkbox"/> Highest	802.11b 802.11g 802.11n HT20 802.11n HT40	<input checked="" type="checkbox"/> Lowest <input checked="" type="checkbox"/> Middle <input checked="" type="checkbox"/> Highest	<input checked="" type="checkbox"/>	<input type="checkbox"/>	<input type="checkbox"/>	<input type="checkbox"/>	complies
§15.109	RX spurious emissions	-/-	-/-	-/-	-/-	<input checked="" type="checkbox"/>	<input type="checkbox"/>	<input type="checkbox"/>	<input type="checkbox"/>	complies

	radiated									
§15.209(a)	TX spurious Emissions radiated < 30 MHz	802.11b	-/-	802.11b	-/-	<input checked="" type="checkbox"/>	<input type="checkbox"/>	<input type="checkbox"/>	<input type="checkbox"/>	complies
§15.107(a) §15.207	Conducted Emissions < 30 MHz	802.11b	-/-	802.11b	-/-	<input checked="" type="checkbox"/>	<input type="checkbox"/>	<input type="checkbox"/>	<input type="checkbox"/>	complies

Remark:

1. The measurement uncertainty is not included in the test result.
2. NA = Not Applicable; NP = Not Performed

Preliminary tests were performed in different data rate to find the worst radiated emission. The data rate shown in the table below is the worst-case rate with respect to the specific test item. Investigation has been done on all the possible configurations for searching the worst cases. The following table is a list of the test modes shown in this test report.

Test Items	Mode	Data Rate	Channel
Maximum Peak Conducted Output Power Power Spectral Density 6dB Bandwidth Spurious RF conducted emission Radiated Emission 9kHz~1GHz& Radiated Emission 1GHz~10 th Harmonic	11b/DSSS	1 Mbps	1/6/11
	11g/OFDM	6 Mbps	1/6/11
	11n(20MHz)/OFDM	6.5Mbps	1/6/11
	11n(40MHz)/OFDM	13.5Mbps	3/6/9
Band Edge	11b/DSSS	1 Mbps	1/11
	11g/OFDM	6 Mbps	1/11
	11n(20MHz)/OFDM	6.5Mbps	1/11
	11n(40MHz)/OFDM	13.5Mbps	3/9

3.5. Statement of the measurement uncertainty

The data and results referenced in this document are true and accurate. The reader is cautioned that there may be errors within the calibration limits of the equipment and facilities. The measurement uncertainty was calculated for all measurements listed in this test report acc. to CISPR 16 - 4 „Specification for radio disturbance and immunity measuring apparatus and methods – Part 4: Uncertainty in EMC Measurements“ and is documented in the Shenzhen CTL Testing Technology Co., Ltd quality system acc. to DIN EN ISO/IEC 17025. Furthermore, the component and process variability of devices similar to that tested may result in additional deviation. The manufacturer has the sole responsibility of continued compliance of the device.

Hereafter the best measurement capability for Shenzhen CTL Testing Technology Co., Ltd laboratory is reported:

Test	Range	Measurement Uncertainty	Notes
Radiated Emission	30~1000MHz	4.10 dB	(1)
Radiated Emission	1~18GHz	4.32 dB	(1)
Radiated Emission	18-40GHz	5.54 dB	(1)
Conducted Disturbance	0.15~30MHz	3.20 dB	(1)

- (1) This uncertainty represents an expanded uncertainty expressed at approximately the 95% confidence level using a coverage factor of k=2.

3.6. Equipments Used during the Test

Test Equipment	Manufacturer	Model No.	Serial No.	Calibration Date	Calibration Due Date
LISN	R&S	ENV216	3560.6550.12	2015/06/02	2016/06/01
LISN	R&S	ESH2-Z5	860014/010	2015/06/02	2016/06/01
Bilog Antenna	Sunol Sciences Corp.	JB1	A061713	2015/06/02	2016/06/01
EMI Test Receiver	R&S	ESCI	103710	2015/06/02	2016/06/01
Spectrum Analyzer	Agilent	N9030A	MY49430428	2015/05/21	2016/05/20
Controller	EM Electronics	Controller EM 1000	N/A	2015/05/21	2016/05/20
Horn Antenna	Sunol Sciences Corp.	DRH-118	A062013	2015/05/19	2016/05/18
Active Loop Antenna	SCHWARZBECK	FMZB1519	1519-037	2015/05/19	2016/05/18
Amplifier	Agilent	8349B	3008A02306	2015/05/19	2016/05/18
Amplifier	Agilent	8447D	2944A10176	2015/05/19	2016/05/18
Temperature/ Humidity Meter	Gangxing	CTH-608	02	2015/05/20	2016/05/19
High-Pass Filter	K&L	9SH10- 2700/X12750-O/O	N/A	2015/05/20	2016/05/19
High-Pass Filter	K&L	41H10- 1375/U12750-O/O	N/A	2015/05/20	2016/05/19
Coaxial Cables	HUBER+SUHNER	SUCOFLEX 104PEA-10M	10m	2015/06/02	2016/06/01
Coaxial Cables	HUBER+SUHNER	SUCOFLEX 104PEA-3M	3m	2015/06/02	2016/06/01
Coaxial Cables	HUBER+SUHNER	SUCOFLEX 104PEA-3M	3m	2015/06/02	2016/06/01
RF Cable	Megalon	RF-A303	N/A	2015/06/02	2016/06/01
Power Sensor	R&S	NRP-Z4	823.3618.03	2015/06/02	2016/06/01
Power Meter	R&S	NRVS	1020.1809.02	2015/06/02	2016/06/01
Spectrum Analyzer	R&S	FSU26	1166.1660.98	2015/06/02	2016/06/01

4. TEST CONDITIONS AND RESULTS

4.1. AC Power Conducted Emission

TEST CONFIGURATION

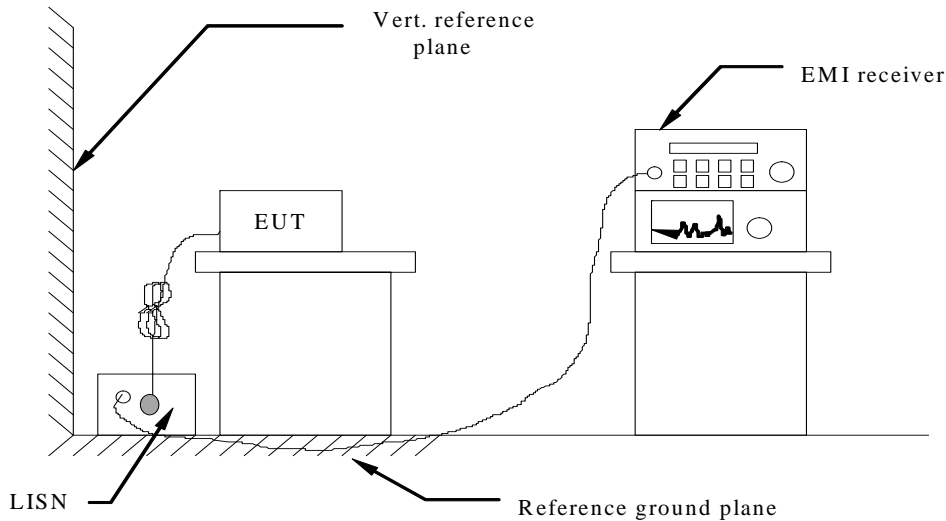

TEST PROCEDURE

1. The equipment was set up as per the test configuration to simulate typical actual usage per the user's manual. The EUT is a tabletop system, a wooden table with a height of 0.8 meters is used and is placed on the ground plane as per ANSI C63.10-2013
2. Support equipment, if needed, was placed as per ANSI C63.10-2013
3. All I/O cables were positioned to simulate typical actual usage as per ANSI C63.10-2013
4. The EUT received DC5V power from PC, the adapter of PC received AC120V/60Hz power through a Line Impedance Stabilization Network (LISN) which supplied power source and was grounded to the ground plane.
5. All support equipments received AC power from a second LISN, if any.
6. The EUT test program was started. Emissions were measured on each current carrying line of the EUT using a spectrum Analyzer / Receiver connected to the LISN powering the EUT. The LISN has two monitoring points: Line 1 (Hot Side) and Line 2 (Neutral Side). Two scans were taken: one with Line 1 connected to Analyzer / Receiver and Line 2 connected to a 50 ohm load; the second scan had Line 1 connected to a 50 ohm load and Line 2 connected to the Analyzer / Receiver.
7. Analyzer / Receiver scanned from 150 KHz to 30MHz for emissions in each of the test modes.
8. During the above scans, the emissions were maximized by cable manipulation.

AC Power Conducted Emission Limit

For intentional device, according to § 15.207(a) AC Power Conducted Emission Limits is as following :

Frequency range (MHz)	Limit (dBuV)	
	Quasi-peak	Average
0.15-0.5	66 to 56*	56 to 46*
0.5-5	56	46
5-30	60	50

* Decreases with the logarithm of the frequency.

TEST RESULTS

Remark:

1. We tested three positions and recorded worst case at WLAN IEEE 802.11b Link mode.

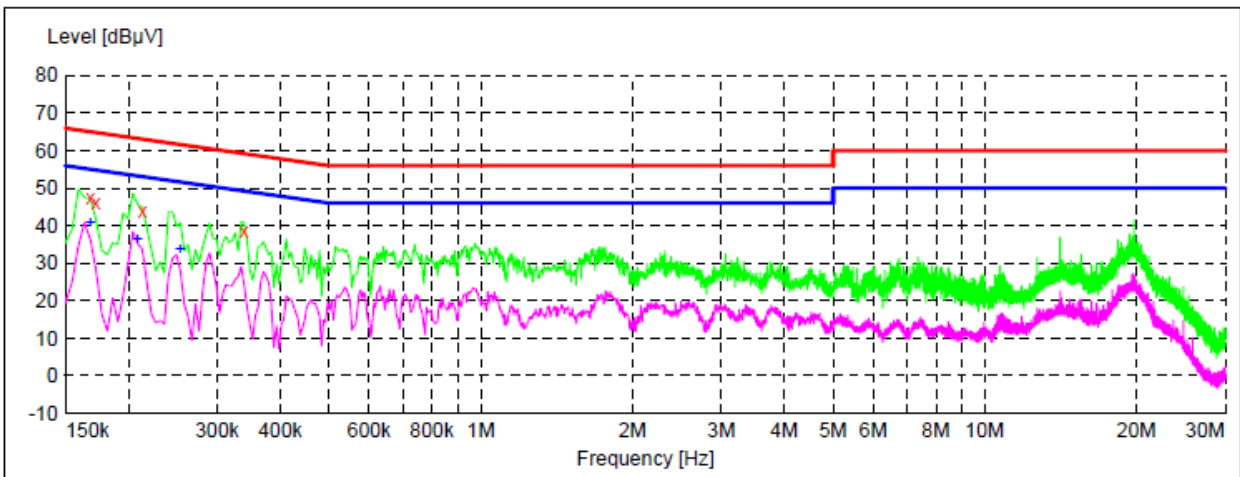

x x x MES GTS1012110_fin

MEASUREMENT RESULT: "GTS1012110_fin"

10/12/2015 2:38PM

Frequency MHz	Level dBµV	Transd dB	Limit dBµV	Margin dB	Detector	Line	PE
0.168000	47.40	10.0	65	17.7	QP	L1	GND
0.172500	46.10	10.0	65	18.7	QP	L1	GND
0.213000	43.90	10.0	63	19.2	QP	L1	GND
0.339000	38.70	9.9	59	20.5	QP	L1	GND

MEASUREMENT RESULT: "GTS1012110_fin2"

10/12/2015 2:38PM

Frequency MHz	Level dBµV	Transd dB	Limit dBµV	Margin dB	Detector	Line	PE
0.168000	40.60	10.0	55	14.5	AV	L1	GND
0.208500	36.50	10.0	53	16.8	AV	L1	GND
0.253500	33.80	9.9	52	17.8	AV	L1	GND

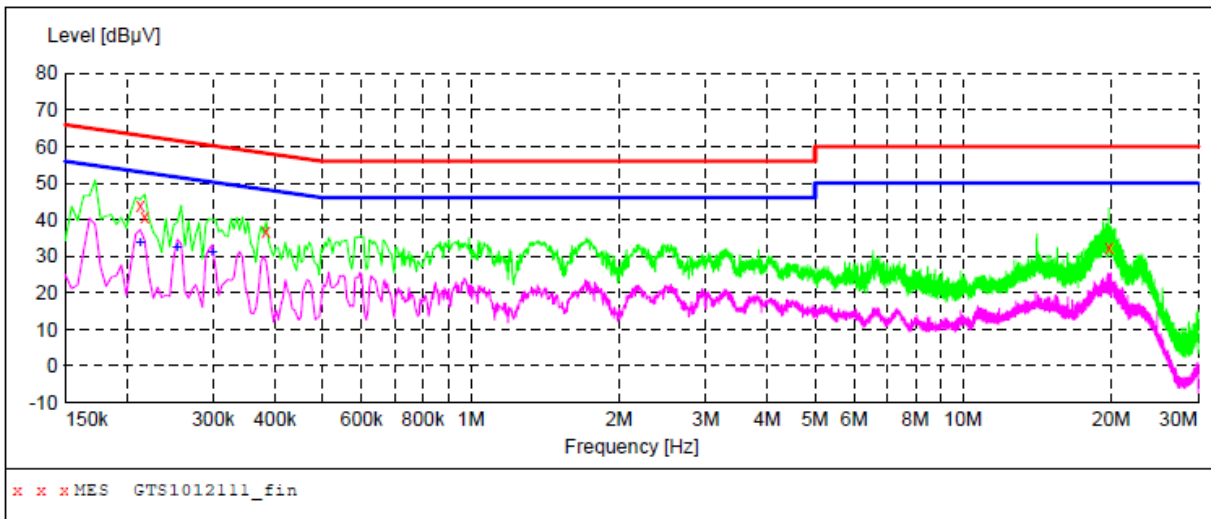

MEASUREMENT RESULT: "GTS1012111_fin"

10/12/2015 2:41PM

Frequency MHz	Level dBµV	Transd dB	Limit dBµV	Margin dB	Detector	Line	PE
0.213000	43.90	10.0	63	19.2	QP	N	GND
0.217500	41.00	10.0	63	21.9	QP	N	GND
0.384000	36.90	9.8	58	21.3	QP	N	GND
19.765500	32.60	7.1	60	27.4	QP	N	GND

MEASUREMENT RESULT: "GTS1012111_fin2"

10/12/2015 2:41PM

Frequency MHz	Level dBµV	Transd dB	Limit dBµV	Margin dB	Detector	Line	PE
0.213000	33.60	10.0	53	19.5	AV	N	GND
0.253500	32.50	9.9	52	19.1	AV	N	GND
0.298500	31.20	9.9	50	19.1	AV	N	GND

4.2. Radiated Emission

TEST CONFIGURATION

Frequency range 9 KHz – 30MHz

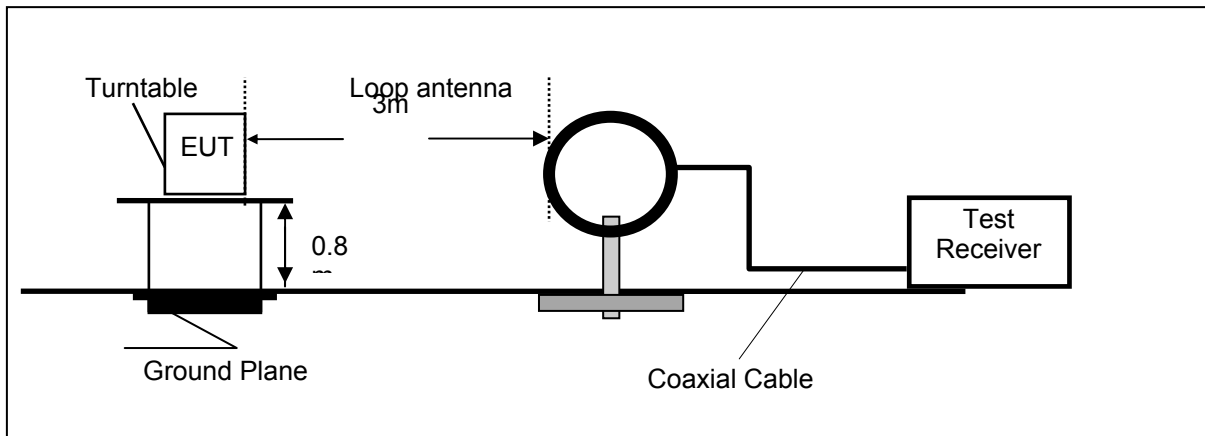

Frequency range 30MHz – 1000MHz

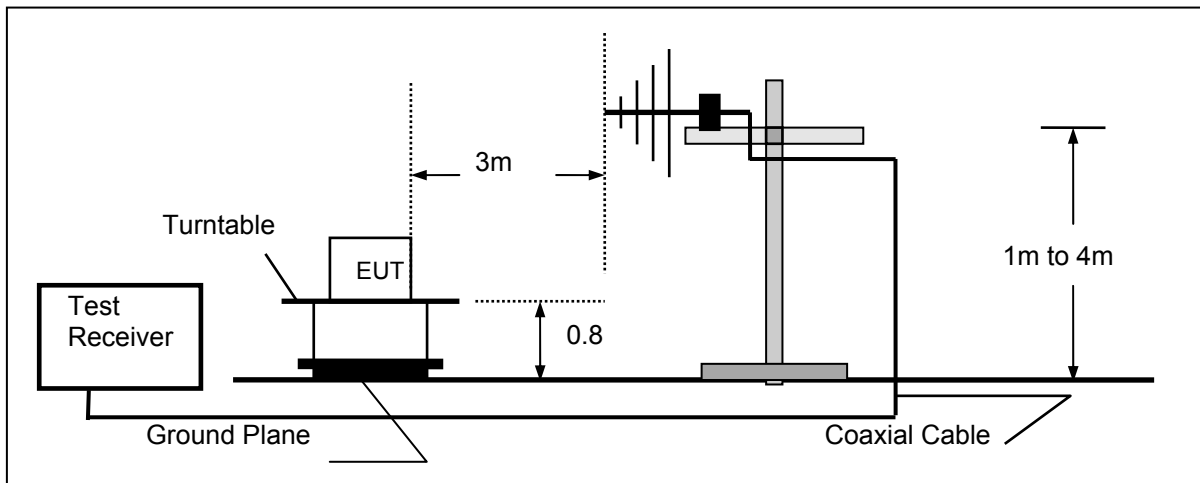

Frequency range above 1GHz-25GHz

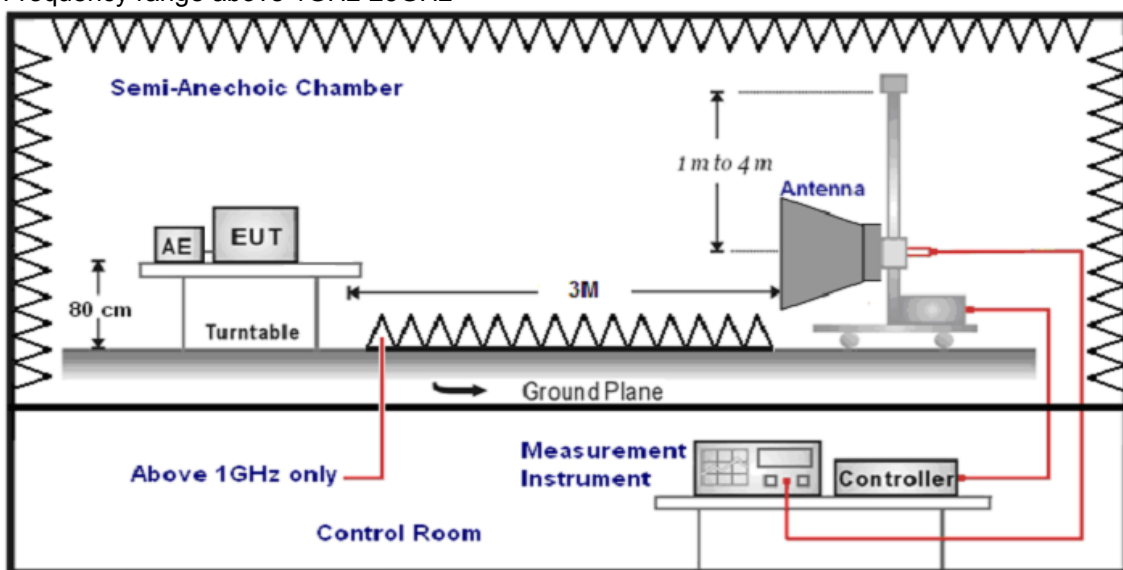

TEST PROCEDURE

1. The EUT was placed on a turn table which is 0.8m above ground plane.
2. Maximum procedure was performed by raising the receiving antenna from 1m to 4m and rotating the turn table from 0° to 360° to acquire the highest emissions from EUT.

3. And also, each emission was to be maximized by changing the polarization of receiving antenna both horizontal and vertical.
4. Repeat above procedures until all frequency measurements have been completed.
5. The EUT minimum operation frequency was 32.768KHz and maximum operation frequency was 2480MHz.so radiated emission test frequency band from 9KHz to 25GHz.
6. The distance between test antenna and EUT as following table states:

Test Frequency range	Test Antenna Type	Test Distance
9KHz-30MHz	Active Loop Antenna	3
30MHz-1GHz	Ultra-Broadband Antenna	3
1GHz-18GHz	Double Ridged Horn Antenna	3
18GHz-25GHz	Horn Antenna	1

7. Setting test receiver/spectrum as following table states:

Test Frequency range	Test Receiver/Spectrum Setting	Detector
9KHz-150KHz	RBW=200Hz/VBW=3KHz,Sweep time=Auto	QP
150KHz-30MHz	RBW=9KHz/VBW=100KHz,Sweep time=Auto	QP
30MHz-1GHz	RBW=120KHz/VBW=1000KHz,Sweep time=Auto	QP
1GHz-40GHz	Peak Value: RBW=1MHz/VBW=3MHz, Sweep time=Auto Average Value: RBW=1MHz/VBW=10Hz, Sweep time=Auto	Peak

Field Strength Calculation

The field strength is calculated by adding the Antenna Factor and Cable Factor and subtracting the Amplifier Gain and Duty Cycle Correction Factor(if any) from the measured reading. The basic equation with a sample calculation is as follows:

$$FS = RA + AF + CL - AG$$

Where FS = Field Strength	CL = Cable Attenuation Factor (Cable Loss)
RA = Reading Amplitude	AG = Amplifier Gain
AF = Antenna Factor	

$$Transd=AF +CL-AG$$

RADIATION LIMIT

For intentional device, according to § 15.209(a), the general requirement of field strength of radiated emission from intentional radiators at a distance of 3 meters shall not exceed the following table. According to § 15.247(d), in any 100kHz bandwidth outside the frequency band in which the EUT is operating, the radio frequency power that is produced by the intentional radiator shall be at least 20dB below that in the100kHz bandwidth within the band that contains the highest level of desired power.

The pre-test have done for the EUT in three axes and found the worst emission at position shown in test setup photos.

Frequency (MHz)	Distance (Meters)	Radiated (dBµV/m)	Radiated (µV/m)
0.009-0.49	3	20log(2400/F(KHz))+40log(300/3)	2400/F(KHz)
0.49-1.705	3	20log(24000/F(KHz))+ 40log(30/3)	24000/F(KHz)
1.705-30	3	20log(30)+ 40log(30/3)	30
30-88	3	40.0	100
88-216	3	43.5	150
216-960	3	46.0	200
Above 960	3	54.0	500

TEST RESULTS

Remark:

1. We tested three positions and recorded worst case at WLAN IEEE 802.11b Link mode for below 1GHz.

For 9 KHz-30MHz

Frequency (MHz)	Corrected Reading (dBuV/m)@3m	FCC Limit (dBuV/m) @3m	Margin (dB)	Detector	Result
20.51	49.37	69.54	20.17	QP	PASS
25.77	47.62	69.54	21.92	QP	PASS

For 30MHz-1GHz

Horizontal

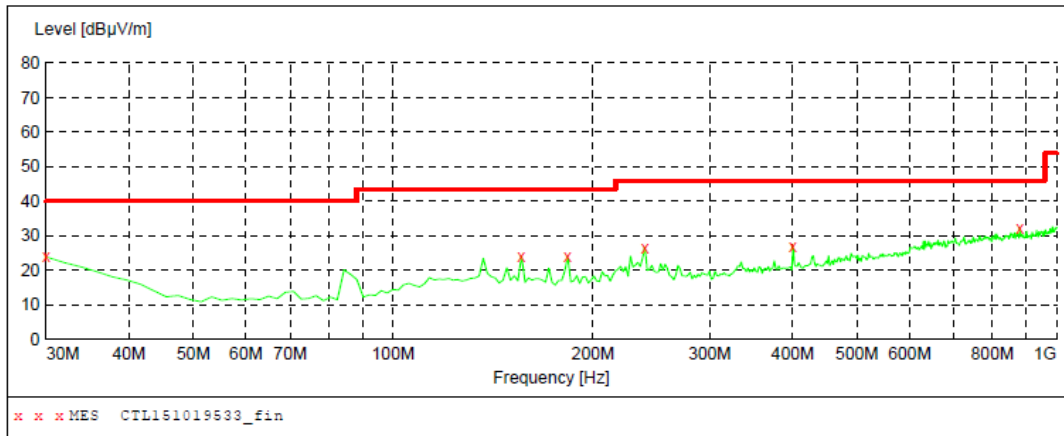

MEASUREMENT RESULT: "CTL151019533_fin"

10/19/2015 10:57AM

Frequency MHz	Level dBuV/m	Transd dB	Limit dBuV/m	Margin dB	Det.	Height cm	Azimuth deg	Polarization
30.000000	23.90	20.8	40.0	16.1	QP	0.0	0.00	HORIZONTAL
156.100000	24.20	13.7	43.5	19.3	QP	0.0	0.00	HORIZONTAL
183.260000	24.00	13.1	43.5	19.5	QP	0.0	0.00	HORIZONTAL
239.520000	26.70	13.7	46.0	19.3	QP	0.0	0.00	HORIZONTAL
400.540000	27.00	17.9	46.0	19.0	QP	0.0	0.00	HORIZONTAL
879.720000	32.40	25.5	46.0	13.6	QP	0.0	0.00	HORIZONTAL

Vertical

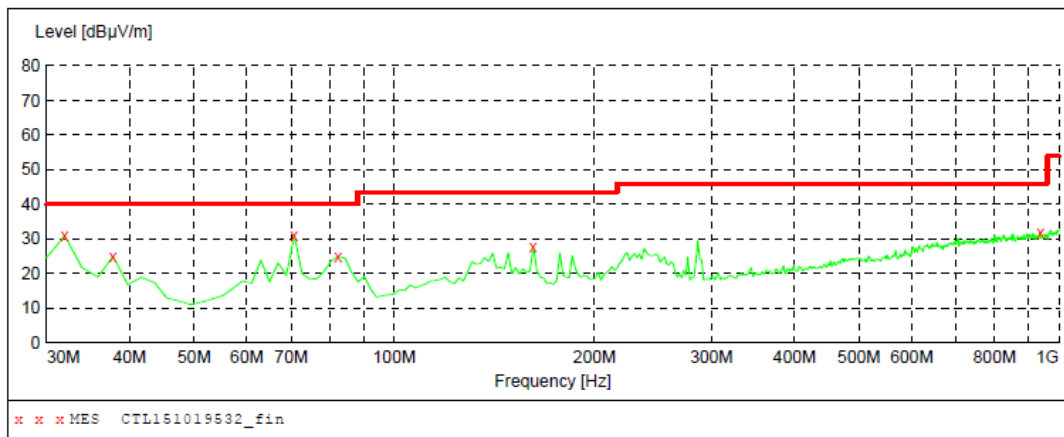

MEASUREMENT RESULT: "CTL151019532_fin"

10/19/2015 10:55AM

Frequency MHz	Level dBuV/m	Transd dB	Limit dBuV/m	Margin dB	Det.	Height cm	Azimuth deg	Polarization
31.940000	30.90	19.2	40.0	9.1	QP	0.0	0.00	VERTICAL
37.760000	25.00	14.8	40.0	15.0	QP	0.0	0.00	VERTICAL
70.740000	30.90	8.2	40.0	9.1	QP	0.0	0.00	VERTICAL
82.380000	24.90	8.7	40.0	15.1	QP	0.0	0.00	VERTICAL
161.920000	27.90	13.6	43.5	15.6	QP	0.0	0.00	VERTICAL
937.920000	31.90	26.4	46.0	14.1	QP	0.0	0.00	VERTICAL

For 1GHz to 25GHz

802.11b Mode (above 1GHz)

Frequency(MHz):				2412			Polarity:			HORIZONTAL		
No.	Frequency (MHz)	Emission Level (dBuV/m)		Limit (dBuV/m)	Margin (dB)	Antenna Height (m)	Table Angle (Degree)	Raw Value (dBuV)	Antenna Factor (dB/m)	Cable Factor (dB)	Pre-amplifier	Correction Factor (dB/m)
1	4824	65.46	PK	74.00	8.54	1.00	48	67.56	31.6	7.00	36.5	2.10
1	4824	43.52	AV	54.00	10.48	1.00	48	45.62	31.6	7.00	36.5	2.10
2	7236	58.72	PK	74.00	15.28	1.00	110	69.65	37.33	8.90	35.3	10.93
2	7236	42.50	AV	54.00	11.50	1.00	110	53.43	37.33	8.90	35.3	10.93

Frequency(MHz):				2412			Polarity:			VERTICAL		
No.	Frequency (MHz)	Emission Level (dBuV/m)		Limit (dBuV/m)	Margin (dB)	Antenna Height (m)	Table Angle (Degree)	Raw Value (dBuV)	Antenna Factor (dB/m)	Cable Factor (dB)	Pre-amplifier	Correction Factor (dB/m)
1	4824	64.68	PK	74.00	9.32	1.00	120	66.78	31.60	7.00	36.50	2.10
1	4824	42.84	AV	54.00	11.16	1.00	120	44.94	31.60	7.00	36.50	2.10
2	7236	59.43	PK	74.00	14.57	1.00	145	70.36	37.33	8.90	35.30	10.93
2	7236	40.54	AV	54.00	13.46	1.00	145	51.47	37.33	8.90	35.30	10.93

Frequency(MHz):				2437			Polarity:			HORIZONTAL		
No.	Frequency (MHz)	Emission Level (dBuV/m)		Limit (dBuV/m)	Margin (dB)	Antenna Height (m)	Table Angle (Degree)	Raw Value (dBuV)	Antenna Factor (dB/m)	Cable Factor (dB)	Pre-amplifier	Correction Factor (dB/m)
1	4874.00	65.47	PK	74.00	8.53	1.00	110	67.59	31.02	7.60	36.5	2.12
1	4874.00	46.56	AV	54.00	7.44	1.00	110	48.68	31.02	7.60	36.5	2.12
2	7311.00	57.65	PK	74.00	16.35	1.00	181	68.73	37.28	8.60	34.8	11.08
2	7311.00	40.21	AV	54.00	13.79	1.00	181	51.29	37.28	8.60	34.8	11.08

Frequency(MHz):				2437			Polarity:			VERTICAL		
No.	Frequency (MHz)	Emission Level (dBuV/m)		Limit (dBuV/m)	Margin (dB)	Antenna Height (m)	Table Angle (Degree)	Raw Value (dBuV)	Antenna Factor (dB/m)	Cable Factor (dB)	Pre-amplifier	Correction Factor (dB/m)
1	4874.00	66.87	PK	74.00	7.13	1.00	105	68.99	31.02	7.60	36.5	2.12
1	4874.00	47.64	AV	54.00	6.36	1.00	105	49.76	31.02	7.60	36.5	2.12
2	7311.00	58.61	PK	74.00	15.39	1.00	75	69.69	37.28	8.60	34.8	11.08
2	7311.00	40.27	AV	54.00	13.73	1.00	75	51.35	37.28	8.60	34.8	11.08

Frequency(MHz):				2462			Polarity:			HORIZONTAL		
No.	Frequency (MHz)	Emission Level (dBuV/m)		Limit (dBuV/m)	Margin (dB)	Antenna Height (m)	Table Angle (Degree)	Raw Value (dBuV)	Antenna Factor (dB/m)	Cable Factor (dB)	Pre-amplifier	Correction Factor (dB/m)
1	4924.00	64.35	PK	74.00	9.65	1.00	130	67.55	31.58	7.82	36.2	3.20
1	4924.00	43.72	AV	54.00	10.28	1.00	130	46.92	31.58	7.82	36.2	3.20
2	7386.00	59.08	PK	74.00	14.92	1.00	120	71.02	38.51	8.73	35.3	11.94
2	7386.00	39.46	AV	54.00	14.54	1.00	120	51.40	38.51	8.73	35.3	11.94

Frequency(MHz):				2462			Polarity:			VERTICAL		
No.	Frequency (MHz)	Emission Level (dBuV/m)		Limit (dBuV/m)	Margin (dB)	Antenna Height (m)	Table Angle (Degree)	Raw Value (dBuV)	Antenna Factor (dB/m)	Cable Factor (dB)	Pre-amplifier	Correction Factor (dB/m)
1	4924.00	65.29	PK	74.00	8.71	1.00	25	68.49	31.58	7.82	36.2	3.20
1	4924.00	46.77	AV	54.00	7.23	1.00	25	49.97	31.58	7.82	36.2	3.20
2	7386.00	58.31	PK	74.00	15.69	1.00	78	70.25	38.51	8.73	35.3	11.94
2	7386.00	41.94	AV	54.00	12.06	1.00	78	53.88	38.51	8.73	35.3	11.94

802.11g Mode (above 1GHz)

Frequency(MHz):				2412			Polarity:			HORIZONTAL		
No.	Frequency (MHz)	Emission Level (dBuV/m)		Limit (dBuV/m)	Margin (dB)	Antenna Height (m)	Table Angle (Degree)	Raw Value (dBuV)	Antenna Factor (dB/m)	Cable Factor (dB)	Pre-amplifier	Correction Factor (dB/m)
1	4824	65.05	PK	74.00	8.95	1.00	65	67.15	31.6	7.00	36.5	2.10
1	4824	44.35	AV	54.00	9.65	1.00	65	46.45	31.6	7.00	36.5	2.10
2	7236	55.82	PK	74.00	8.18	1.00	120	66.75	37.33	8.90	35.3	10.93
2	7236	43.06	AV	54.00	10.94	1.00	120	53.99	37.33	8.90	35.3	10.93

Frequency(MHz):				2412			Polarity:			VERTICAL		
No.	Frequency (MHz)	Emission Level (dBuV/m)		Limit (dBuV/m)	Margin (dB)	Antenna Height (m)	Table Angle (Degree)	Raw Value (dBuV)	Antenna Factor (dB/m)	Cable Factor (dB)	Pre-amplifier	Correction Factor (dB/m)
1	4824	65.98	PK	74.00	8.02	1.00	134	68.08	31.60	7.00	36.50	2.10
1	4824	44.37	AV	54.00	9.63	1.00	134	46.47	31.60	7.00	36.50	2.10
2	7236	56.15	PK	74.00	17.85	1.00	116	67.08	37.33	8.90	35.30	10.93
2	7236	42.64	AV	54.00	11.36	1.00	116	53.57	37.33	8.90	35.30	10.93

Frequency(MHz):				2437			Polarity:			HORIZONTAL		
No.	Frequency (MHz)	Emission Level (dBuV/m)		Limit (dBuV/m)	Margin (dB)	Antenna Height (m)	Table Angle (Degree)	Raw Value (dBuV)	Antenna Factor (dB/m)	Cable Factor (dB)	Pre-amplifier	Correction Factor (dB/m)
1	4874.00	67.64	PK	74.00	6.36	1.00	105	69.76	31.02	7.60	36.5	2.12
1	4874.00	46.52	AV	54.00	7.48	1.00	105	48.64	31.02	7.60	36.5	2.12
2	7311.00	57.45	PK	74.00	16.55	1.00	139	68.53	37.28	8.60	34.8	11.08
2	7311.00	39.82	AV	54.00	14.18	1.00	139	50.90	37.28	8.60	34.8	11.08

Frequency(MHz):				2437			Polarity:			VERTICAL		
No.	Frequency (MHz)	Emission Level (dBuV/m)		Limit (dBuV/m)	Margin (dB)	Antenna Height (m)	Table Angle (Degree)	Raw Value (dBuV)	Antenna Factor (dB/m)	Cable Factor (dB)	Pre-amplifier	Correction Factor (dB/m)
1	4874.00	67.45	PK	74.00	6.55	1.00	76	69.57	31.02	7.60	36.5	2.12
1	4874.00	46.54	AV	54.00	7.46	1.00	76	48.66	31.02	7.60	36.5	2.12
2	7311.00	60.32	PK	74.00	13.68	1.00	186	71.40	37.28	8.60	34.8	11.08
2	7311.00	43.24	AV	54.00	10.76	1.00	186	54.32	37.28	8.60	34.8	11.08

Frequency(MHz):				2462			Polarity:			HORIZONTAL		
No.	Frequency (MHz)	Emission Level (dBuV/m)		Limit (dBuV/m)	Margin (dB)	Antenna Height (m)	Table Angle (Degree)	Raw Value (dBuV)	Antenna Factor (dB/m)	Cable Factor (dB)	Pre-amplifier	Correction Factor (dB/m)
1	4924.00	65.24	PK	74.00	8.76	1.00	135	68.44	31.58	7.82	36.2	3.20
1	4924.00	46.72	AV	54.00	7.28	1.00	135	49.92	31.58	7.82	36.2	3.20
2	7386.00	59.62	PK	74.00	14.38	1.00	120	71.56	38.51	8.73	35.3	11.94
2	7386.00	40.65	AV	54.00	13.35	1.00	120	52.59	38.51	8.73	35.3	11.94

Frequency(MHz):				2462			Polarity:			VERTICAL		
No.	Frequency (MHz)	Emission Level (dBuV/m)		Limit (dBuV/m)	Margin (dB)	Antenna Height (m)	Table Angle (Degree)	Raw Value (dBuV)	Antenna Factor (dB/m)	Cable Factor (dB)	Pre-amplifier	Correction Factor (dB/m)
1	4924.00	67.82	PK	74.00	6.18	1.00	68	71.02	31.58	7.82	36.2	3.20
1	4924.00	46.24	AV	54.00	7.76	1.00	68	49.44	31.58	7.82	36.2	3.20
2	7386.00	57.63	PK	74.00	16.37	1.00	110	69.57	38.51	8.73	35.3	11.94
2	7386.00	41.35	AV	54.00	12.65	1.00	110	53.29	38.51	8.73	35.3	11.94

802.11n HT20 Mode (above 1GHz)

Frequency(MHz):				2412			Polarity:			HORIZONTAL		
No.	Frequency (MHz)	Emission Level (dBuV/m)		Limit (dBuV/m)	Margin (dB)	Antenna Height (m)	Table Angle (Degree)	Raw Value (dBuV)	Antenna Factor (dB/m)	Cable Factor (dB)	Pre-amplifier	Correction Factor (dB/m)
1	4824	63.45	PK	74.00	10.55	1.00	55	65.55	31.6	7.00	36.5	2.10
1	4824	42.34	AV	54.00	11.66	1.00	55	44.44	31.6	7.00	36.5	2.10
2	7236	57.48	PK	74.00	16.52	1.00	110	68.41	37.33	8.90	35.3	10.93
2	7236	42.34	AV	54.00	11.66	1.00	110	53.27	37.33	8.90	35.3	10.93

Frequency(MHz):				2412			Polarity:			VERTICAL		
No.	Frequency (MHz)	Emission Level (dBuV/m)		Limit (dBuV/m)	Margin (dB)	Antenna Height (m)	Table Angle (Degree)	Raw Value (dBuV)	Antenna Factor (dB/m)	Cable Factor (dB)	Pre-amplifier	Correction Factor (dB/m)
1	4824	58.36	PK	74.00	15.64	1.00	135	60.46	31.60	7.00	36.50	2.10
1	4824	45.52	AV	54.00	8.48	1.00	135	47.62	31.60	7.00	36.50	2.10
2	7236	58.24	PK	74.00	15.76	1.00	145	69.17	37.33	8.90	35.30	10.93
2	7236	41.34	AV	54.00	12.66	1.00	145	52.27	37.33	8.90	35.30	10.93

Frequency(MHz):				2437			Polarity:			HORIZONTAL		
No.	Frequency (MHz)	Emission Level (dBuV/m)		Limit (dBuV/m)	Margin (dB)	Antenna Height (m)	Table Angle (Degree)	Raw Value (dBuV)	Antenna Factor (dB/m)	Cable Factor (dB)	Pre-amplifier	Correction Factor (dB/m)
1	4874.00	57.51	PK	74.00	16.49	1.00	100	59.63	31.02	7.60	36.5	2.12
1	4874.00	45.87	AV	54.00	8.13	1.00	100	47.99	31.02	7.60	36.5	2.12
2	7311.00	58.62	PK	74.00	15.38	1.00	175	69.76	37.28	8.60	34.8	11.08
2	7311.00	39.34	AV	54.00	14.66	1.00	175	50.42	37.28	8.60	34.8	11.08

Frequency(MHz):				2437			Polarity:			VERTICAL		
No.	Frequency (MHz)	Emission Level (dBuV/m)		Limit (dBuV/m)	Margin (dB)	Antenna Height (m)	Table Angle (Degree)	Raw Value (dBuV)	Antenna Factor (dB/m)	Cable Factor (dB)	Pre-amplifier	Correction Factor (dB/m)
1	4874.00	57.64	PK	74.00	16.36	1.00	100	59.76	31.02	7.60	36.5	2.12
1	4874.00	45.34	AV	54.00	8.66	1.00	100	47.46	31.02	7.60	36.5	2.12
2	7311.00	57.21	PK	74.00	16.79	1.00	120	68.29	37.28	8.60	34.8	11.08
2	7311.00	43.69	AV	54.00	10.31	1.00	120	54.77	37.28	8.60	34.8	11.08

Frequency(MHz):				2462			Polarity:			HORIZONTAL		
No.	Frequency (MHz)	Emission Level (dBuV/m)		Limit (dBuV/m)	Margin (dB)	Antenna Height (m)	Table Angle (Degree)	Raw Value (dBuV)	Antenna Factor (dB/m)	Cable Factor (dB)	Pre-amplifier	Correction Factor (dB/m)
1	4924.00	56.34	PK	74.00	17.66	1.00	148	59.54	31.58	7.82	36.2	3.20
1	4924.00	42.31	AV	54.00	11.69	1.00	148	45.51	31.58	7.82	36.2	3.20
2	7386.00	57.82	PK	74.00	16.18	1.00	120	69.76	38.51	8.73	35.3	11.94
2	7386.00	40.67	AV	54.00	13.33	1.00	120	52.61	38.51	8.73	35.3	11.94

Frequency(MHz):				2462			Polarity:			VERTICAL		
No.	Frequency (MHz)	Emission Level (dBuV/m)		Limit (dBuV/m)	Margin (dB)	Antenna Height (m)	Table Angle (Degree)	Raw Value (dBuV)	Antenna Factor (dB/m)	Cable Factor (dB)	Pre-amplifier	Correction Factor (dB/m)
1	4924.00	56.43	PK	74.00	17.57	1.00	58	59.63	31.58	7.82	36.2	3.20
1	4924.00	47.59	AV	54.00	6.41	1.00	58	50.79	31.58	7.82	36.2	3.20
2	7386.00	57.34	PK	74.00	16.66	1.00	146	69.28	38.51	8.73	35.3	11.94
2	7386.00	41.67	AV	54.00	12.33	1.00	146	53.61	38.51	8.73	35.3	11.94

802.11n HT40 Mode (above 1GHz)

Frequency(MHz):				2422			Polarity:			HORIZONTAL		
No.	Frequency (MHz)	Emission Level (dBuV/m)		Limit (dBuV/m)	Margin (dB)	Antenna Height (m)	Table Angle (Degree)	Raw Value (dBuV)	Antenna Factor (dB/m)	Cable Factor (dB)	Pre-amplifier	Correction Factor (dB/m)
1	4844	58.31	PK	74.00	15.69	1.00	48	60.45	31.62	7.02	36.5	2.14
1	4844	45.24	AV	54.00	8.76	1.00	48	47.38	31.62	7.02	36.5	2.14
2	7266	55.23	PK	74.00	18.77	1.00	132	66.21	37.35	8.93	35.3	10.98
2	7266	40.47	AV	54.00	13.53	1.00	132	51.45	37.35	8.93	35.3	10.98

Frequency(MHz):				2422			Polarity:			VERTICAL		
No.	Frequency (MHz)	Emission Level (dBuV/m)		Limit (dBuV/m)	Margin (dB)	Antenna Height (m)	Table Angle (Degree)	Raw Value (dBuV)	Antenna Factor (dB/m)	Cable Factor (dB)	Pre-amplifier	Correction Factor (dB/m)
1	4844	58.42	PK	74.00	15.58	1.00	130	60.56	31.62	7.02	36.50	2.14
1	4844	44.15	AV	54.00	9.85	1.00	130	46.29	31.62	7.02	36.50	2.14
2	7266	56.62	PK	74.00	17.38	1.00	175	67.60	37.35	8.93	35.30	10.98
2	7266	39.72	AV	54.00	14.28	1.00	175	50.70	37.35	8.93	35.30	10.98

Frequency(MHz):				2437			Polarity:			HORIZONTAL		
No.	Frequency (MHz)	Emission Level (dBuV/m)		Limit (dBuV/m)	Margin (dB)	Antenna Height (m)	Table Angle (Degree)	Raw Value (dBuV)	Antenna Factor (dB/m)	Cable Factor (dB)	Pre-amplifier	Correction Factor (dB/m)
1	4874.00	57.54	PK	74.00	16.46	1.00	105	59.66	31.02	7.60	36.5	2.12
1	4874.00	45.62	AV	54.00	8.38	1.00	105	47.74	31.02	7.60	36.5	2.12
2	7311.00	58.68	PK	74.00	15.32	1.00	180	69.76	37.28	8.60	34.8	11.08
2	7311.00	39.57	AV	54.00	14.43	1.00	180	50.65	37.28	8.60	34.8	11.08

Frequency(MHz):				2437			Polarity:			VERTICAL		
No.	Frequency (MHz)	Emission Level (dBuV/m)		Limit (dBuV/m)	Margin (dB)	Antenna Height (m)	Table Angle (Degree)	Raw Value (dBuV)	Antenna Factor (dB/m)	Cable Factor (dB)	Pre-amplifier	Correction Factor (dB/m)
1	4874.00	56.57	PK	74.00	17.43	1.00	120	58.69	31.02	7.60	36.5	2.12
1	4874.00	45.98	AV	54.00	8.02	1.00	120	48.40	31.02	7.60	36.5	2.12
2	7311.00	57.62	PK	74.00	16.38	1.00	125	68.70	37.28	8.60	34.8	11.08
2	7311.00	42.65	AV	54.00	11.35	1.00	125	53.73	37.28	8.60	34.8	11.08

Frequency(MHz):				2452			Polarity:			HORIZONTAL		
No.	Frequency (MHz)	Emission Level (dBuV/m)		Limit (dBuV/m)	Margin (dB)	Antenna Height (m)	Table Angle (Degree)	Raw Value (dBuV)	Antenna Factor (dB/m)	Cable Factor (dB)	Pre-amplifier	Correction Factor (dB/m)
1	4904.00	55.64	PK	74.00	18.36	1.00	137	58.79	31.55	7.80	36.2	3.15
1	4904.00	43.97	AV	54.00	10.03	1.00	137	47.12	31.55	7.80	36.2	3.15
2	7356.00	56.32	PK	74.00	17.68	1.00	129	68.18	38.47	8.69	35.3	11.86
2	7356.00	40.05	AV	54.00	13.95	1.00	129	51.91	38.47	8.69	35.3	11.86

Frequency(MHz):				2452			Polarity:			VERTICAL		
No.	Frequency (MHz)	Emission Level (dBuV/m)		Limit (dBuV/m)	Margin (dB)	Antenna Height (m)	Table Angle (Degree)	Raw Value (dBuV)	Antenna Factor (dB/m)	Cable Factor (dB)	Pre-amplifier	Correction Factor (dB/m)
1	4904.00	56.52	PK	74.00	17.48	1.00	110	59.67	31.55	7.80	36.2	3.15
1	4904.00	47.86	AV	54.00	6.14	1.00	110	51.01	31.55	7.80	36.2	3.15
2	7356.00	55.69	PK	74.00	18.31	1.00	185	67.55	38.47	8.69	35.3	11.86
2	7356.00	42.38	AV	54.00	11.62	1.00	185	54.24	38.47	8.69	35.3	11.86

REMARKS:

1. Emission level (dBuV/m) = Raw Value (dBuV) + Correction Factor (dB/m)
2. Correction Factor (dB/m) = Antenna Factor (dB/m) + Cable Factor (dB) - Pre-amplifier Factor
3. Margin value = Limit value - Emission level.
4. -- Mean the PK detector measured value is below average limit.
5. The other emission levels were very low against the limit.

4.3. Maximum Peak Output Power

TEST CONFIGURATION

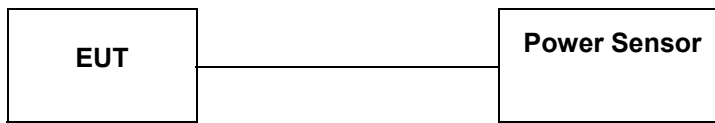

TEST PROCEDURE

According to KDB558074 D01 DTS Measurement Guidance Section 9.1 Maximum peak conducted output power,9.1.1. The maximum peak conducted output power may be measured using a broadband peak RF power meter. The power meter shall have a video bandwidth that is greater than or equal to the DTS bandwidth and shall utilize a fast-responding diode detector.

LIMIT

The Maximum Peak Output Power Measurement is 30dBm.

TEST RESULTS

Type	Channel	Output power PK (dBm)	Output power AV (dBm)	Limit (dBm)	Result
802.11b	1	12.32	9.46	30.00	Pass
	6	11.73	9.24		
	11	11.28	9.15		
802.11g	1	13.72	9.31	30.00	Pass
	6	13.35	8.83		
	11	14.11	9.42		
802.11n HT20	1	13.77	9.06	30.00	Pass
	6	14.14	9.24		
	11	14.05	9.12		
802.11n HT40	3	15.65	9.05	30.00	Pass
	6	15.61	9.07		
	9	15.28	8.86		

Remark:

1. The test results including the cable lose.

4.4. Power Spectral Density

TEST CONFIGURATION

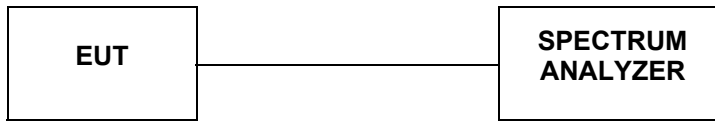

TEST PROCEDURE

According to KDB 558074 D01 V03 Method PKPSD (peak PSD) This procedure shall be used if maximum peak conducted output power was used to demonstrate compliance, and is optional if the maximum conducted (average) output power was used to demonstrate compliance.

1. Set analyzer center frequency to DTS channel center frequency.
2. Set the span to 1.5 times the DTS bandwidth.
3. Set the RBW to: $3 \text{ kHz} \leq \text{RBW} \leq 100 \text{ kHz}$.
4. Set the VBW $\geq 3 \text{ RBW}$.
5. Detector = peak.
6. Sweep time = auto couple.
7. Trace mode = max hold.
8. Allow trace to fully stabilize.
9. Use the peak marker function to determine the maximum amplitude level within the RBW.
10. If measured value exceeds limit, reduce RBW (no less than 3 kHz) and repeat.

LIMIT

For digitally modulated systems, the power spectral density conducted from the intentional radiator to the antenna shall not be greater than 8 dBm in any 3 kHz band during any time interval of continuous transmission.

TEST RESULTS

Type	Channel	Power Spectral Density (dBm/3KHz)	Limit (dBm/3KHz)	Result
802.11b	1	-9.35	8.00	Pass
	6	-9.86		
	11	-10.24		
802.11g	1	-12.50	8.00	Pass
	6	-13.84		
	11	-13.24		
802.11n HT20	1	-15.91	8.00	Pass
	6	-16.60		
	11	-17.19		
802.11n HT40	3	-20.56	8.00	Pass
	6	-19.23		
	9	-20.25		

802.11b

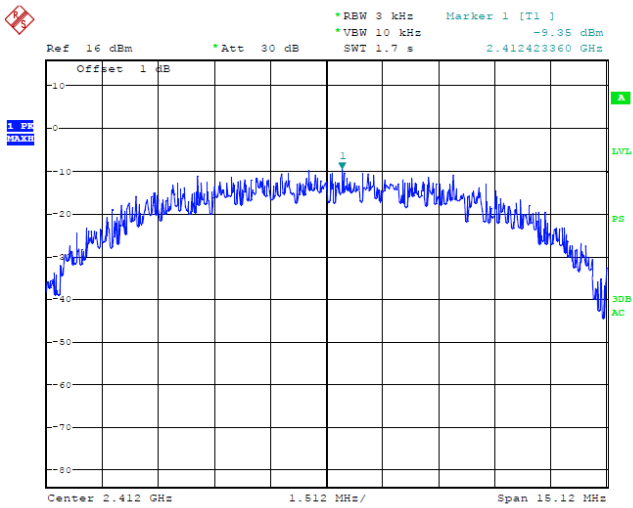

CH1 / 2412 MHz

802.11g

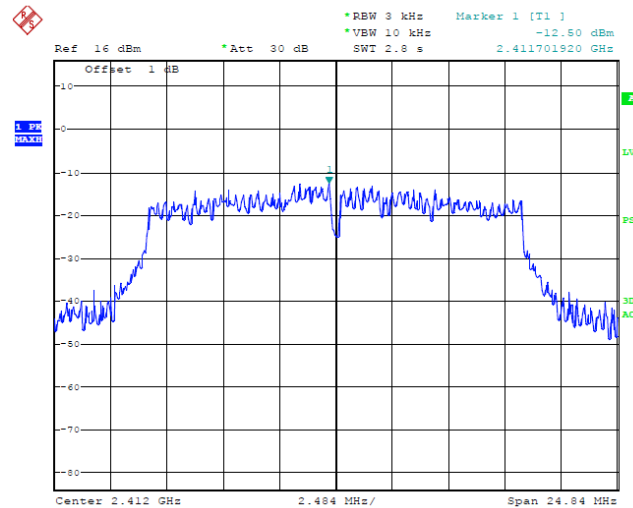

CH1 / 2412 MHz

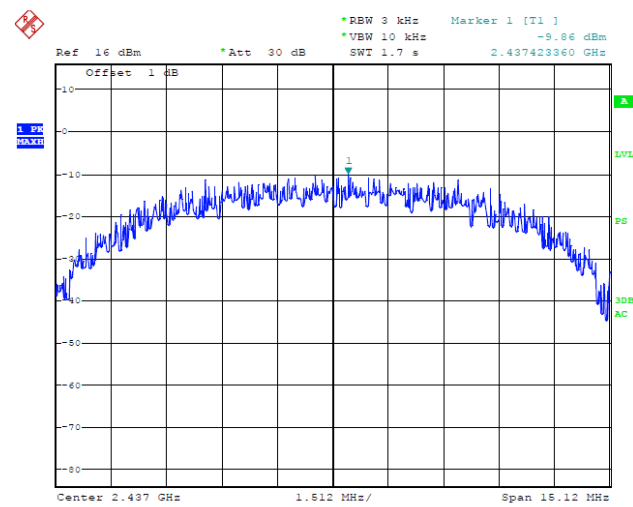

CH6 / 2437 MHz

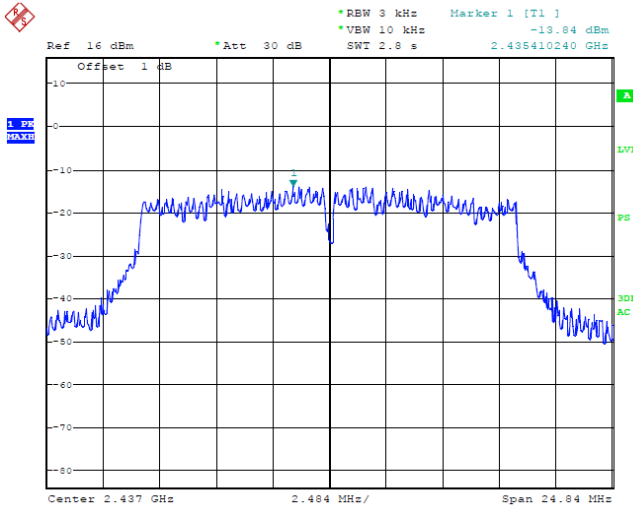

CH6 / 2437 MHz

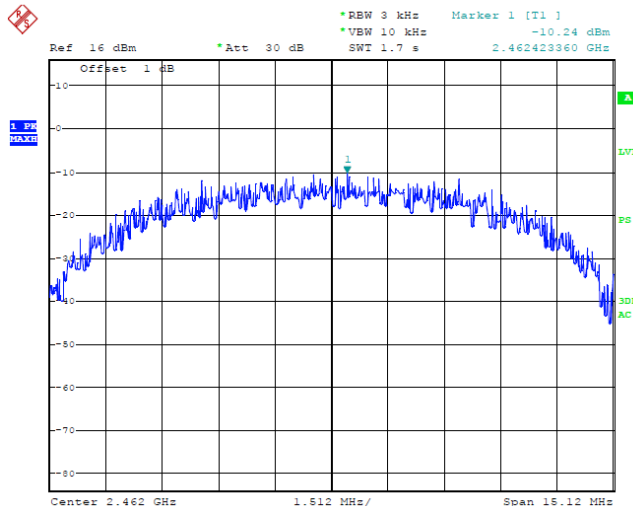

CH11 / 2462 MHz

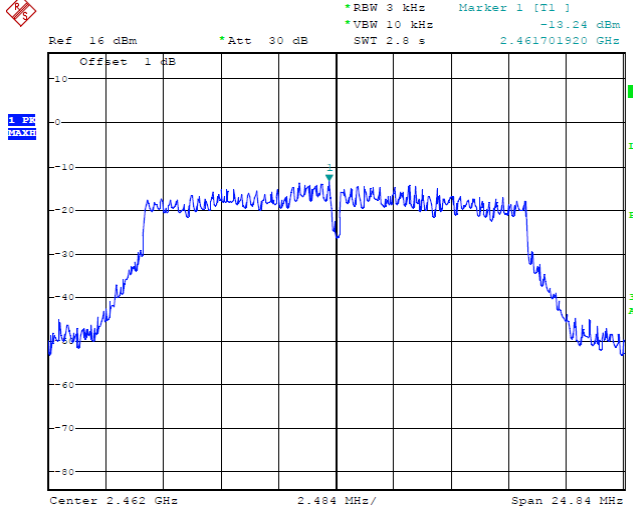

CH11 / 2462 MHz

802.11nHT20

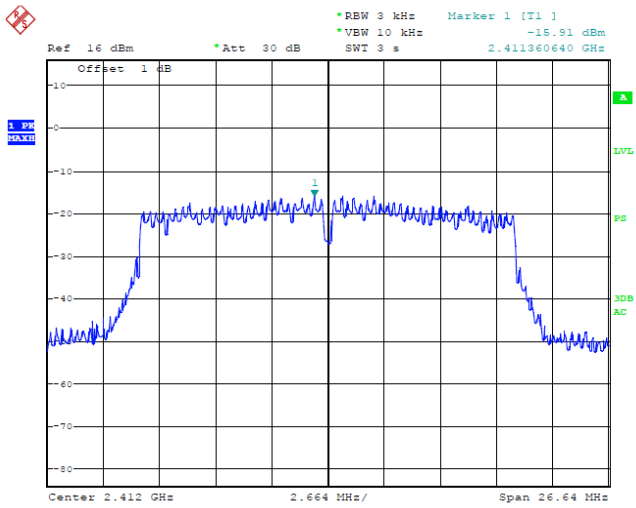

CH1 / 2412 MHz

802.11nHT40

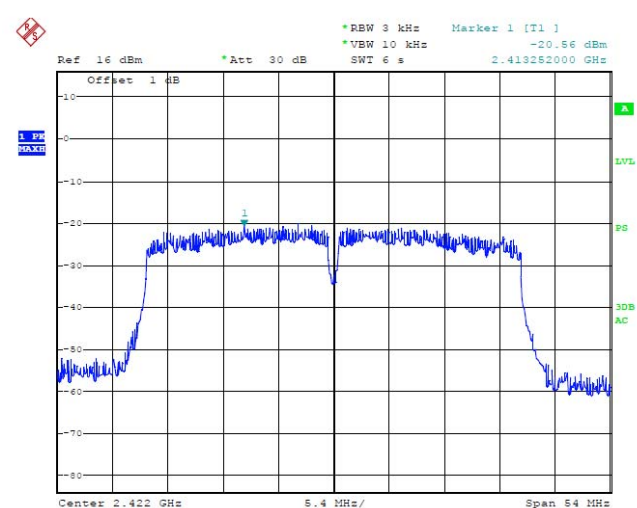

CH3 / 2422 MHz

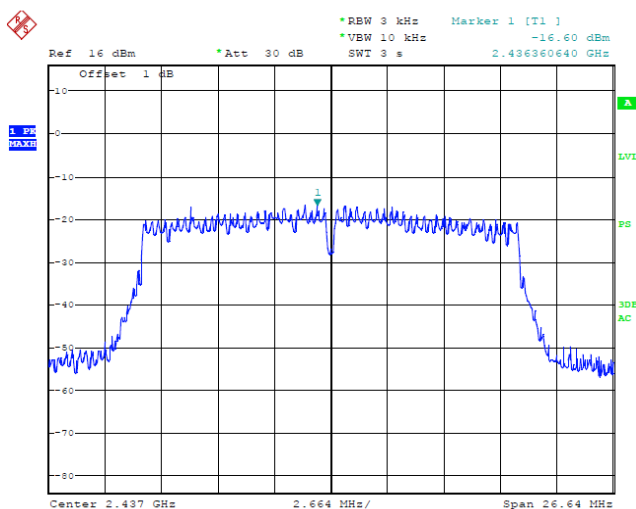

CH6 / 2437 MHz

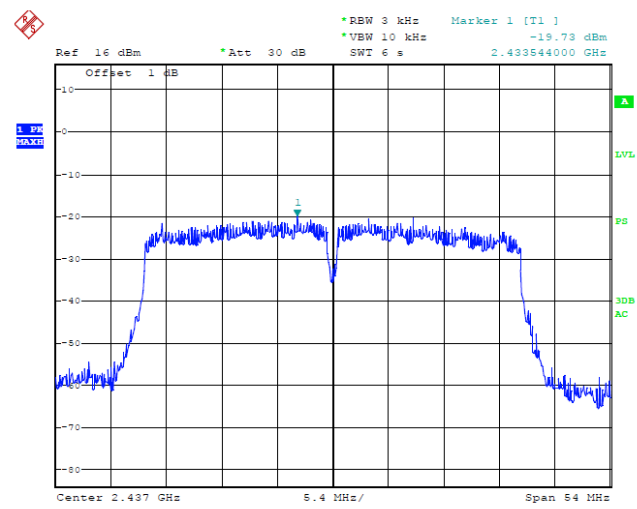

CH6 / 2437 MHz

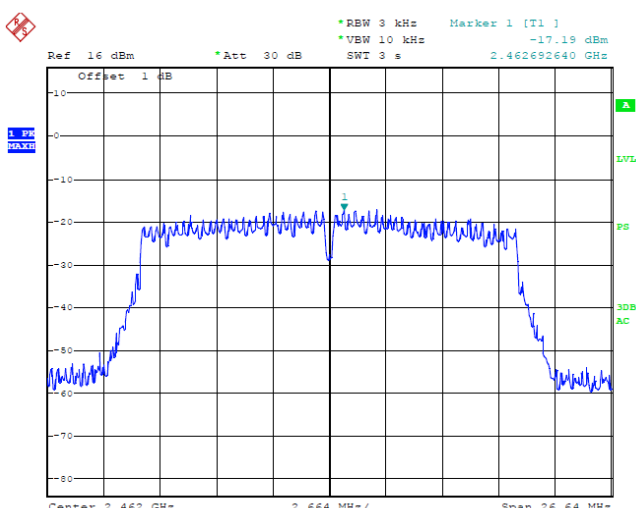

CH11 / 2462 MHz

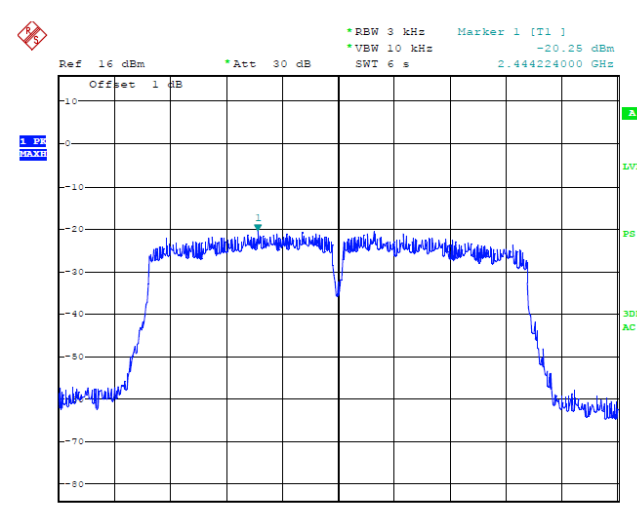

CH9 / 2452 MHz

4.5. 6dB Bandwidth

TEST CONFIGURATION

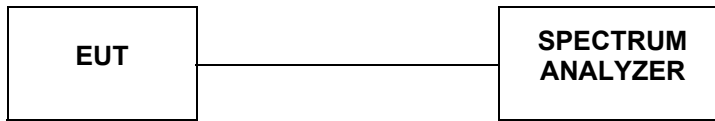

TEST PROCEDURE

The transmitter output was connected to the spectrum analyzer through an attenuator. The bandwidth of the fundamental frequency was measured by spectrum analyzer with RBW=100 KHz and VBW=300KHz. The 6dB bandwidth is defined as the total spectrum the power of which is higher than peak power minus 6dB. According to KDB558074 D01 V03 for one of the following procedures may be used to determine the modulated DTS device signal bandwidth.

1. Set RBW = 100 kHz.
2. Set the video bandwidth (VBW) ≥ 3 RBW.
3. Detector = Peak.
4. Trace mode = max hold.
5. Sweep = auto couple.
6. Allow the trace to stabilize.
7. Measure the maximum width of the emission that is constrained by the frequencies associated with the two outermost amplitude points (upper and lower frequencies) that are attenuated by 6 dB relative to the maximum level measured in the fundamental emission.

LIMIT

For digital modulation systems, the minimum 6 dB bandwidth shall be at least 500 kHz

TEST RESULTS

Type	Channel	6dB Bandwidth (MHz)	Limit (MHz)	Result
802.11b	1	10.08	≥0.500	Pass
	6	10.08		
	11	10.08		
802.11g	1	16.56	≥0.500	Pass
	6	16.56		
	11	16.56		
802.11n HT20	1	17.76	≥0.500	Pass
	6	17.76		
	11	17.76		
802.11n HT40	3	36.00	≥0.500	Pass
	6	36.00		
	9	36.00		

802.11b

802.11g

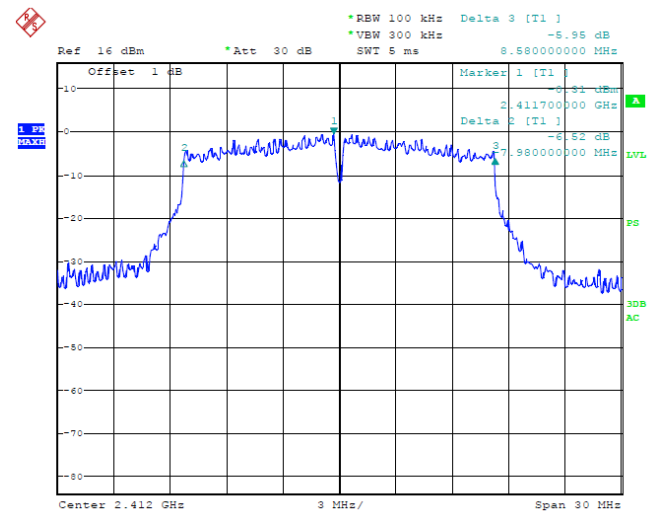
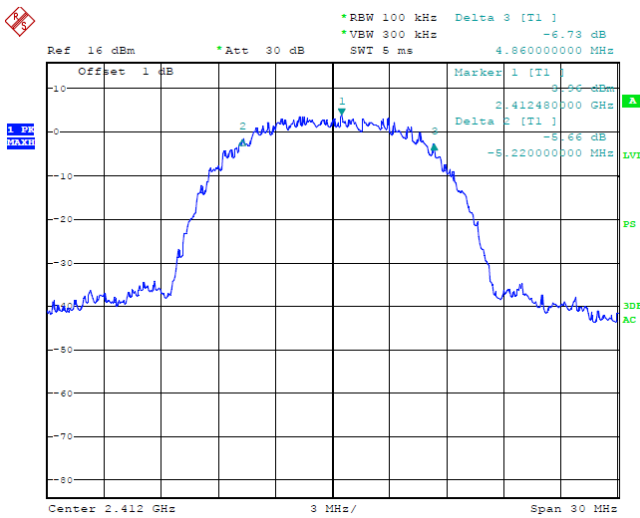

CH1 / 2412 MHz

CH1 / 2412 MHz

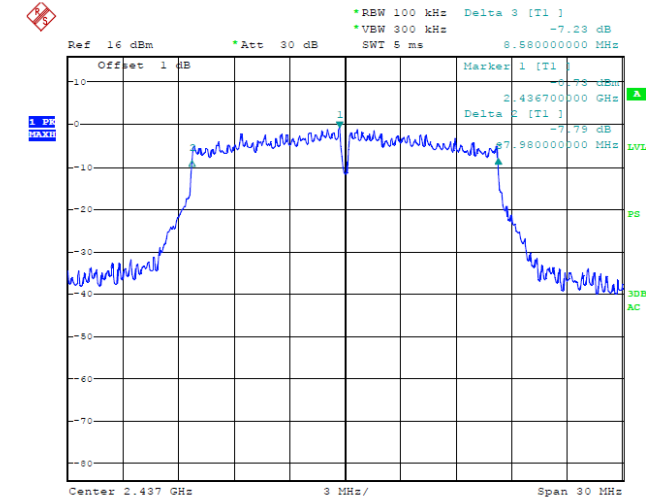
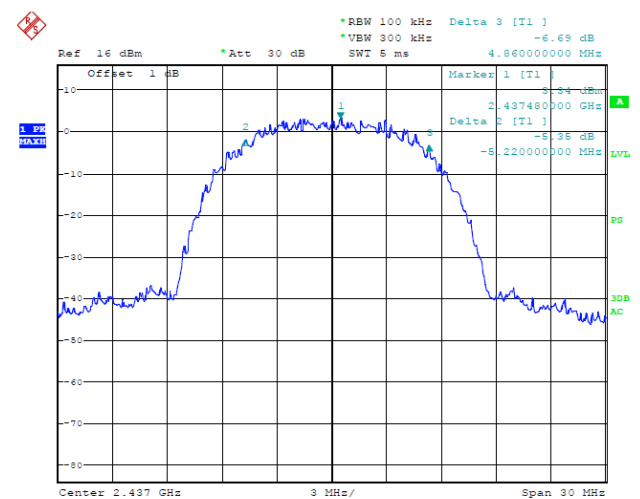

CH6 / 2437 MHz

CH6 / 2437 MHz

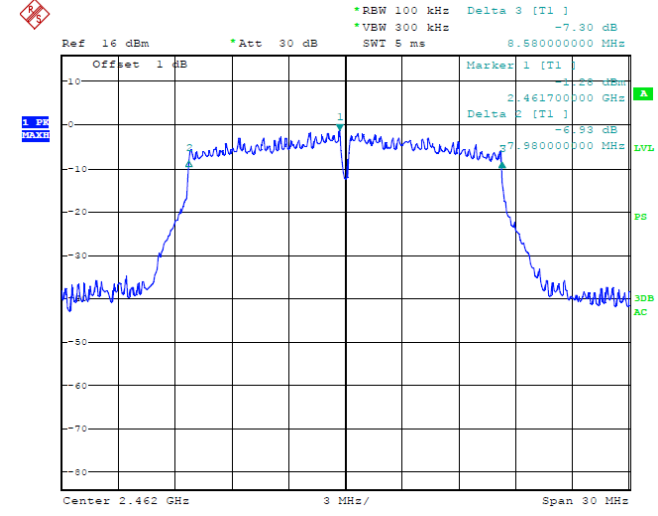
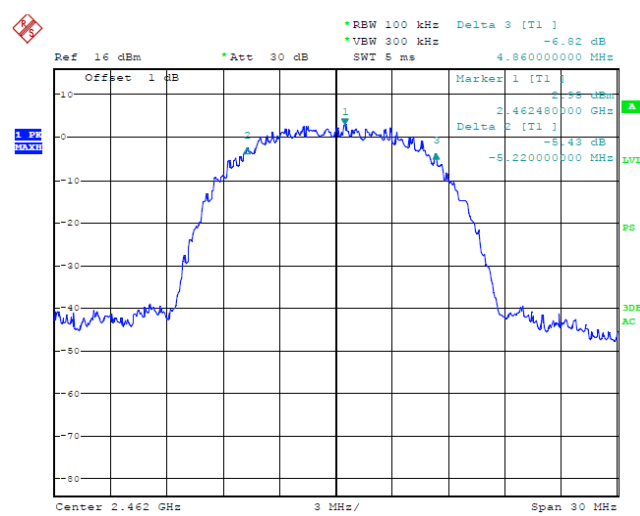

CH11 / 2462 MHz

CH11 / 2462 MHz

802.11n HT20

802.11n HT40

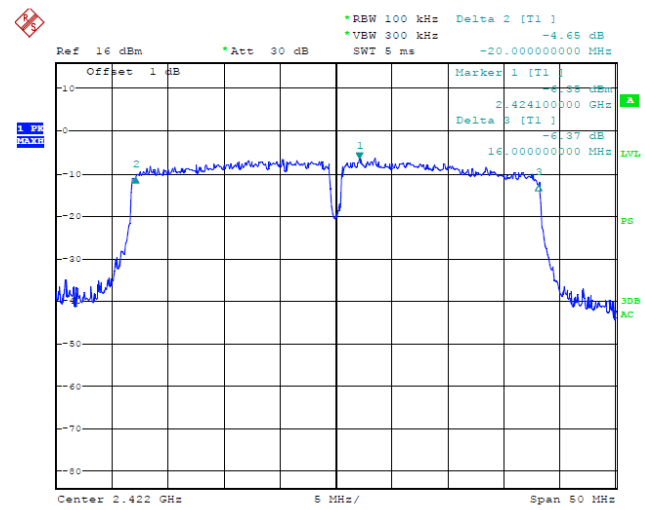
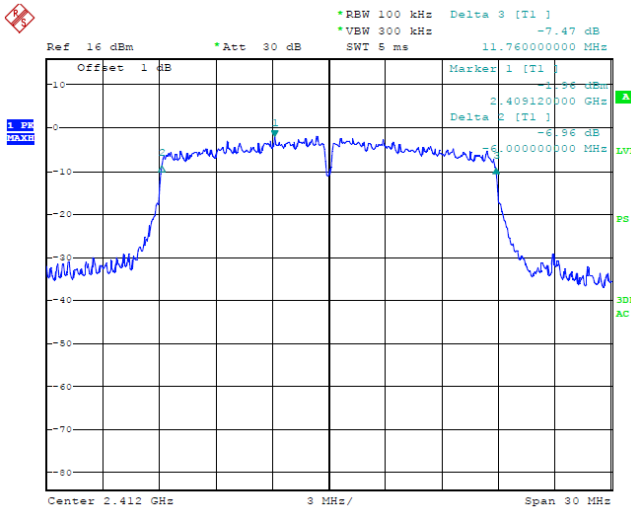

CH1 / 2412 MHz

CH3 / 2422 MHz

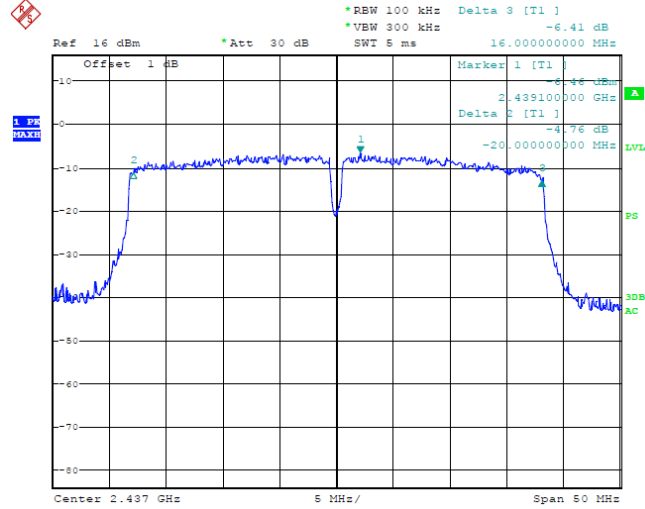
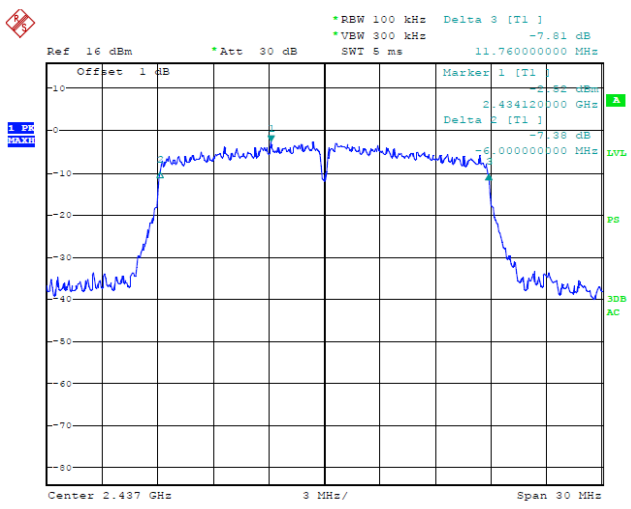

CH6 / 2437 MHz

CH6 / 2437 MHz

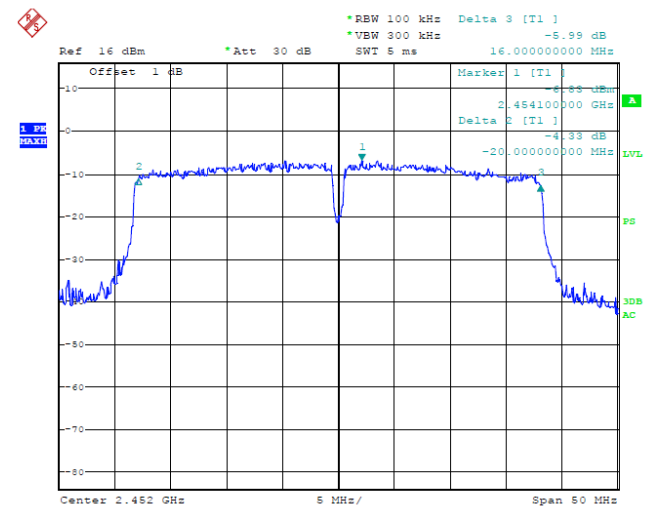
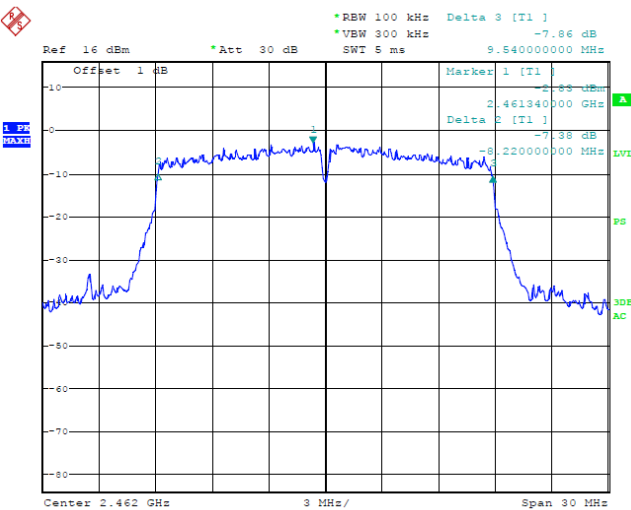

CH11 / 2462 MHz

CH9 / 2452 MHz

4.6. Band Edge Compliance of RF Emission

TEST REQUIREMENT

In any 100 kHz bandwidth outside the frequency band in which the spread spectrum or digitally modulated intentional radiator is operating, the radio frequency power that is produced by the intentional radiator shall be at least 20 dB below that in the 100 kHz bandwidth within the band that contains the highest level of the desired power, based on either an RF conducted or a radiated measurement, provided the transmitter demonstrates compliance with the peak conducted power limits. If the transmitter complies with the conducted power limits based on the use of RMS averaging over a time interval, as permitted under paragraph (b)(3) of this section, the attenuation required under this paragraph shall be 30 dB instead of 20 dB. Attenuation below the general limits specified in §15.209(a) is not required. In addition, radiated emissions which fall in the restricted bands, as defined in §15.205(a), must also comply with the radiated emission limits specified in §15.209(a) (see §15.205(c)).

TEST PROCEDURE

According to KDB 558074 D01 V03 for Antenna-port conducted measurement. Antenna-port conducted measurements may also be used as an alternative to radiated measurements for demonstrating compliance in the restricted frequency bands. If conducted measurements are performed, then proper impedance matching must be ensured and an additional radiated test for cabinet/case spurious emissions is required.

1. Check the calibration of the measuring instrument using either an internal calibrator or a known signal from an external generator.
2. Remove the antenna from the EUT and then connect to a low loss RF cable from the antenna port to a EMI test receiver, then turn on the EUT and make it operate in transmitting mode. Then set it to Low Channel and High Channel within its operating range, and make sure the instrument is operated in its linear range.
3. Set both RBW and VBW of spectrum analyzer to 100 kHz with a convenient frequency span including 100kHz bandwidth from band edge, for Radiated emissions restricted band RBW=1MHz, VBW=3MHz for peak detector and RBW=1MHz, VBW=10Hz for average detector.
4. Measure the highest amplitude appearing on spectral display and set it as a reference level. Plot the graph with marking the highest point and edge frequency.
5. Repeat above procedures until all measured frequencies were complete.
6. Measure the conducted output power (in dBm) using the detector specified by the appropriate regulatory agency (see 12.2.2, 12.2.3, and 12.2.4 for guidance regarding measurement procedures for determining quasi-peak, peak, and average conducted output power, respectively).
7. Add the maximum transmit antenna gain (in dBi) to the measured output power level to determine the EIRP level (see 12.2.5 for guidance on determining the applicable antenna gain)
8. Add the appropriate maximum ground reflection factor to the EIRP level (6 dB for frequencies \leq 30 MHz, 4.7 dB for frequencies between 30 MHz and 1000 MHz, inclusive and 0 dB for frequencies $>$ 1000 MHz).
9. For devices with multiple antenna-ports, measure the power of each individual chain and sum the EIRP of all chains in linear terms (e.g., Watts, mW).
10. Convert the resultant EIRP level to an equivalent electric field strength using the following relationship:

$$E = \text{EIRP} - 20\log D + 104.8$$

where:

E = electric field strength in dB μ V/m,

EIRP = equivalent isotropic radiated power in dBm

D = specified measurement distance in meters.

11. Since the out-of-band characteristics of the EUT transmit antenna will often be unknown, the use of a conservative antenna gain value is necessary. Thus, when determining the EIRP based on the measured conducted power, the upper bound on antenna gain for a device with a single RF output shall be selected as the maximum in-band gain of the antenna across all operating bands, or 2 dBi, whichever is greater. However, for devices that operate in multiple frequency bands while using the same transmit antenna, the highest gain of the antenna within the operating band nearest in frequency to the restricted band emission being measured may be used in lieu of the overall highest gain when the emission is at a frequency that is within 20 percent of the nearest band edge frequency, but in no case shall a value less than 2 dBi be used.
12. Compare the resultant electric field strength level to the applicable regulatory limit.
13. Perform radiated spurious emission test dures until all measured frequencies were complete.

LIMIT

Below -20dB of the highest emission level in operating band.

Radiated emissions which fall in the restricted bands, as defined in § 15.205(a), must also comply with the radiated emission limits specified in § 15.209(a)

TEST RESULTS**4.6.1 For Radiated Bandedge Measurement****802.11b**

Frequency(MHz):			2412			Polarity:			HORIZONTAL		
Frequency (MHz)	Emission Level (dBuV/m)		Limit (dBuV/m)	Margin (dB)	Antenna Height (m)	Table Angle (Degree)	Raw Value (dBuV)	Antenna Factor (dB/m)	Cable Factor (dB)	Pre-amplifier	Correction Factor (dB/m)
2390.00	67.32	PK	74.00	6.68	1.00	135	62.01	27.49	3.32	36.12	-5.31
2390.00	44.52	AV	54.00	9.48	1.00	135	39.21	27.49	3.32	36.12	-5.31
Frequency(MHz):			2412			Polarity:			VERTICAL		
Frequency (MHz)	Emission Level (dBuV/m)		Limit (dBuV/m)	Margin (dB)	Antenna Height (m)	Table Angle (Degree)	Raw Value (dBuV)	Antenna Factor (dB/m)	Cable Factor (dB)	Pre-amplifier	Correction Factor (dB/m)
2390.00	65.62	PK	74.00	8.38	1.00	50	60.3.1	27.49	3.32	36.12	-5.31
2390.00	45.34	AV	54.00	8.66	1.00	50	40.03	27.49	3.32	36.12	-5.31
Frequency(MHz):			2462			Polarity:			HORIZONTAL		
Frequency (MHz)	Emission Level (dBuV/m)		Limit (dBuV/m)	Margin (dB)	Antenna Height (m)	Table Angle (Degree)	Raw Value (dBuV)	Antenna Factor (dB/m)	Cable Factor (dB)	Pre-amplifier	Correction Factor (dB/m)
2483.50	63.24	PK	74.00	10.76	1.00	175	57.52	27.45	3.38	36.55	-5.72
2483.50	44.25	AV	54.00	9.75	1.00	175	38.	27.45	3.38	36.55	-5.72
Frequency(MHz):			2462			Polarity:			VERTICAL		
Frequency (MHz)	Emission Level (dBuV/m)		Limit (dBuV/m)	Margin (dB)	Antenna Height (m)	Table Angle (Degree)	Raw Value (dBuV)	Antenna Factor (dB/m)	Cable Factor (dB)	Pre-amplifier	Correction Factor (dB/m)
2483.50	62.05	PK	74.00	11.95	1.00	138	56.33	27.45	3.38	36.55	-5.72
2483.50	42.57	AV	54.00	11.43	1.00	138	36.85	27.45	3.38	36.55	-5.72

802.11g

Frequency(MHz):			2412			Polarity:			HORIZONTAL		
Frequency (MHz)	Emission Level (dBuV/m)		Limit (dBuV/m)	Margin (dB)	Antenna Height (m)	Table Angle (Degree)	Raw Value (dBuV)	Antenna Factor (dB/m)	Cable Factor (dB)	Pre-amplifier	Correction Factor (dB/m)
2390.00	67.24	PK	74.00	6.76	1.00	140	61.93	27.49	3.32	36.12	-5.31
2390.00	45.28	AV	54.00	8.72	1.00	140	39.97	27.49	3.32	36.12	-5.31
Frequency(MHz):			2412			Polarity:			VERTICAL		
Frequency (MHz)	Emission Level (dBuV/m)		Limit (dBuV/m)	Margin (dB)	Antenna Height (m)	Table Angle (Degree)	Raw Value (dBuV)	Antenna Factor (dB/m)	Cable Factor (dB)	Pre-amplifier	Correction Factor (dB/m)
2390.00	67.06	PK	74.00	6.94	1.00	33	61.75	27.49	3.32	36.12	-5.31
2390.00	46.01	AV	54.00	7.99	1.00	33	40.70	27.49	3.32	36.12	-5.31
Frequency(MHz):			2462			Polarity:			HORIZONTAL		
Frequency (MHz)	Emission Level (dBuV/m)		Limit (dBuV/m)	Margin (dB)	Antenna Height (m)	Table Angle (Degree)	Raw Value (dBuV)	Antenna Factor (dB/m)	Cable Factor (dB)	Pre-amplifier	Correction Factor (dB/m)
2483.50	65.86	PK	74.00	8.14	1.00	48	60.14	27.45	3.38	36.55	-5.72
2483.50	49.35	AV	54.00	4.65	1.00	48	43.63	27.45	3.38	36.55	-5.72
Frequency(MHz):			2462			Polarity:			VERTICAL		
Frequency (MHz)	Emission Level (dBuV/m)		Limit (dBuV/m)	Margin (dB)	Antenna Height (m)	Table Angle (Degree)	Raw Value (dBuV)	Antenna Factor (dB/m)	Cable Factor (dB)	Pre-amplifier	Correction Factor (dB/m)
2483.50	62.42	PK	74.00	11.58	1.00	121	56.70	27.45	3.38	36.55	-5.72
2483.50	50.53	AV	54.00	3.47	1.00	121	44.81	27.45	3.38	36.55	-5.72

802.11 n HT20

Frequency(MHz):			2412			Polarity:			HORIZONTAL		
Frequency (MHz)	Emission Level (dBuV/m)		Limit (dBuV/m)	Margin (dB)	Antenna Height (m)	Table Angle (Degree)	Raw Value (dBuV)	Antenna Factor (dB/m)	Cable Factor (dB)	Pre-amplifier	Correction Factor (dB/m)
2390.00	63.58	PK	74.00	10.42	1.00	140	58.27	27.49	3.32	36.12	-5.31
2390.00	47.40	AV	54.00	6.60	1.00	140	42.09	27.49	3.32	36.12	-5.31
Frequency(MHz):			2412			Polarity:			VERTICAL		
Frequency (MHz)	Emission Level (dBuV/m)		Limit (dBuV/m)	Margin (dB)	Antenna Height (m)	Table Angle (Degree)	Raw Value (dBuV)	Antenna Factor (dB/m)	Cable Factor (dB)	Pre-amplifier	Correction Factor (dB/m)
2390.00	63.24	PK	74.00	10.76	1.00	55	57.93	27.49	3.32	36.12	-5.31
2390.00	48.62	AV	54.00	5.38	1.00	55	43.31	27.49	3.32	36.12	-5.31
Frequency(MHz):			2462			Polarity:			HORIZONTAL		
Frequency (MHz)	Emission Level (dBuV/m)		Limit (dBuV/m)	Margin (dB)	Antenna Height (m)	Table Angle (Degree)	Raw Value (dBuV)	Antenna Factor (dB/m)	Cable Factor (dB)	Pre-amplifier	Correction Factor (dB/m)
2483.50	67.55	PK	74.00	6.45	1.00	125	61.83	27.45	3.38	36.55	-5.72
2483.50	48.57	AV	54.00	5.43	1.00	125	42.85	27.45	3.38	36.55	-5.72
Frequency(MHz):			2462			Polarity:			VERTICAL		
Frequency (MHz)	Emission Level (dBuV/m)		Limit (dBuV/m)	Margin (dB)	Antenna Height (m)	Table Angle (Degree)	Raw Value (dBuV)	Antenna Factor (dB/m)	Cable Factor (dB)	Pre-amplifier	Correction Factor (dB/m)
2483.50	64.06	PK	74.00	9.94	1.00	78	58.34	27.45	3.38	36.55	-5.72
2483.50	47.95	AV	54.00	6.05	1.00	78	42.23	27.45	3.38	36.55	-5.72

802.11n HT40

Frequency(MHz):			2422			Polarity:			HORIZONTAL		
Frequency (MHz)	Emission Level (dBuV/m)		Limit (dBuV/m)	Margin (dB)	Antenna Height (m)	Table Angle (Degree)	Raw Value (dBuV)	Antenna Factor (dB/m)	Cable Factor (dB)	Pre-amplifier	Correction Factor (dB/m)
2390.00	62.84	PK	74.00	11.16	1.00	131	57.53	27.49	3.32	36.12	-5.31
2390.00	46.52	AV	54.00	7.48	1.00	131	41.21	27.49	3.32	36.12	-5.31
Frequency(MHz):			2422			Polarity:			VERTICAL		
Frequency (MHz)	Emission Level (dBuV/m)		Limit (dBuV/m)	Margin (dB)	Antenna Height (m)	Table Angle (Degree)	Raw Value (dBuV)	Antenna Factor (dB/m)	Cable Factor (dB)	Pre-amplifier	Correction Factor (dB/m)
2390.00	65.12	PK	74.00	8.88	1.00	125	59.81	27.49	3.32	36.12	-5.31
2390.00	46.34	AV	54.00	7.66	1.00	125	41.03	27.49	3.32	36.12	-5.31
Frequency(MHz):			2452			Polarity:			HORIZONTAL		
Frequency (MHz)	Emission Level (dBuV/m)		Limit (dBuV/m)	Margin (dB)	Antenna Height (m)	Table Angle (Degree)	Raw Value (dBuV)	Antenna Factor (dB/m)	Cable Factor (dB)	Pre-amplifier	Correction Factor (dB/m)
2483.50	67.98	PK	74.00	6.02	1.00	45	62.26	27.45	3.38	36.55	-5.72
2483.50	45.68	AV	54.00	8.32	1.00	45	39.96	27.45	3.38	36.55	-5.72
Frequency(MHz):			2452			Polarity:			VERTICAL		
Frequency (MHz)	Emission Level (dBuV/m)		Limit (dBuV/m)	Margin (dB)	Antenna Height (m)	Table Angle (Degree)	Raw Value (dBuV)	Antenna Factor (dB/m)	Cable Factor (dB)	Pre-amplifier	Correction Factor (dB/m)
2483.50	66.92	PK	74.00	7.08	1.00	130	61.20	27.45	3.38	36.55	-5.72
2483.50	46.52	AV	54.00	7.46	1.00	130	40.80	27.45	3.38	36.55	-5.72

4.6.2 For Conducted Bandedge Measurement

802.11b			
Frequency (MHz)	Delta Peak to Band emission (dBc)	Limit (dBc)	Verdict
2390.00	-57.28	-20	PASS
2483.50	-57.72	-20	PASS

Ch1 / 2412 MHz	Ch11 / 2462 MHz		

802.11g			
Frequency (MHz)	Delta Peak to Band emission (dBc)	Limit (dBc)	Verdict
2390.00	-44.78	-20	PASS
2483.05	-44.81	-20	PASS

Ch1 / 2412 MHz	Ch11 / 2462 MHz		

802.11n HT20

Frequency (MHz)	Delta Peak to Band emission (dBc)	Limit (dBc)	Verdict
2390.00	-40.43	-20	PASS
2483.50	-39.72	-20	PASS

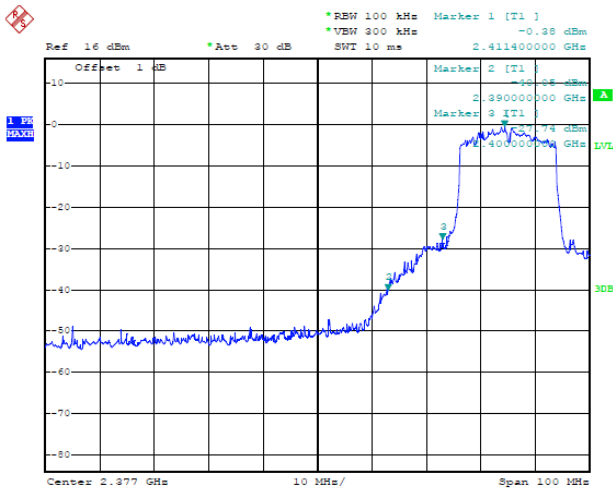

Ch1 / 2412 MHz

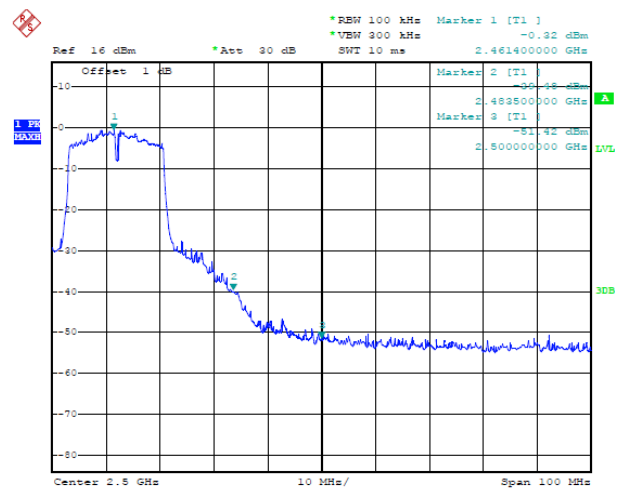

Ch11 / 2462 MHz

802.11n HT40

Frequency (MHz)	Delta Peak to Band emission (dBc)	Limit (dBc)	Verdict
2390.00	-45.89	-20	PASS
2483.5	-48.47	-20	PASS

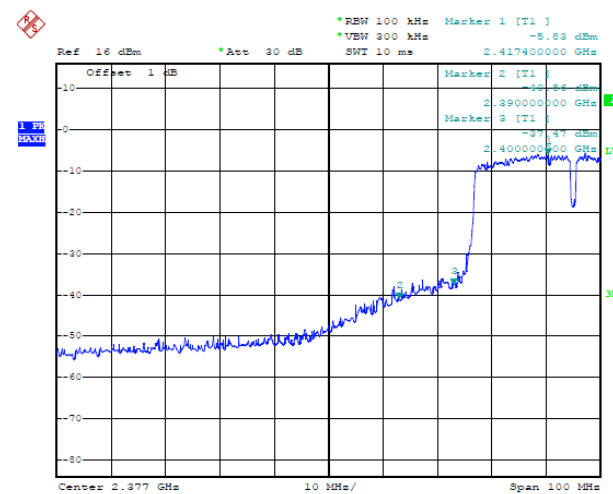

Ch3 / 2422 MHz

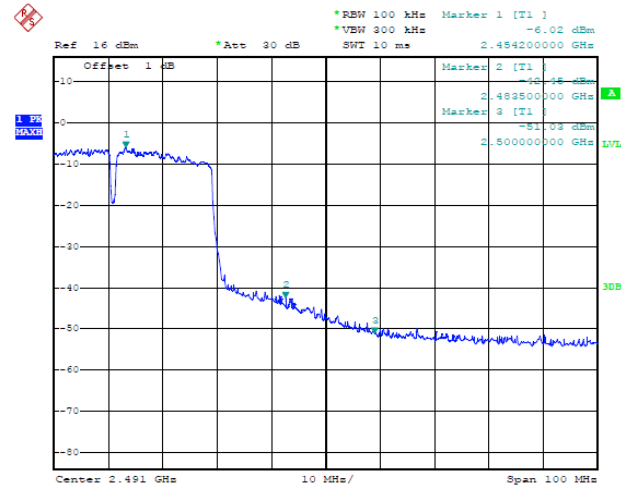

Ch9 / 2452 MHz

4.7. Spurious RF Conducted Emission

TEST CONFIGURATION

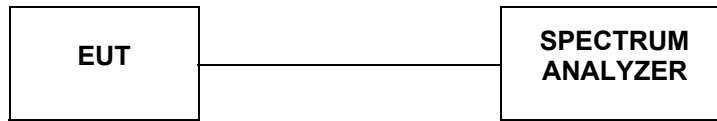

TEST PROCEDURE

The Spurious RF conducted emissions compliance of RF radiated emission should be measured by following the guidance in ANSI C63.10-2009 with respect to maximizing the emission by rotating the EUT, measuring the emission while the EUT is situated in three orthogonal planes (if appropriate), adjusting the measurement antenna height and polarization etc. Set RBW=100kHz and VBW= 300KHz to measure the peak field strength , and mwasure frequency range from 9KHz to 25GHz.

LIMIT

1. Below -20dB of the highest emission level in operating band.
2. Fall in the restricted bands listed in section 15.205. The maximum permitted average field strength is listed in section 15.209.

TEST RESULTS

Remark: The measurement frequency range is from 9KHz to the 10th harmonic of the fundamental frequency. The lowest, middle and highest channels are tested to verify the spurious emissions and bandege measurement data.

The spurious emissions of the 9 kHz to 30MHz are Background and lower than Limit, so we don't recorded it.

Test Mode:

802.11b

Test channel :

1

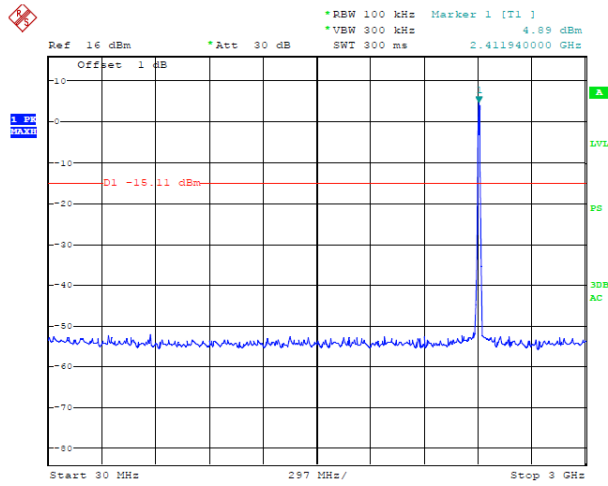

30M Hz~3GHz

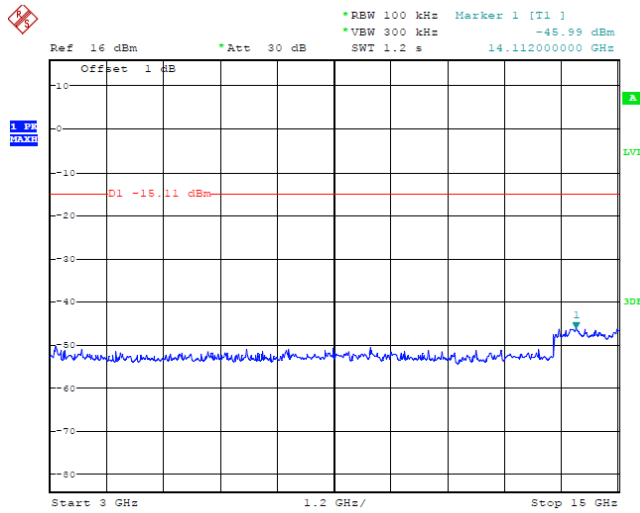

3G Hz~15GHz

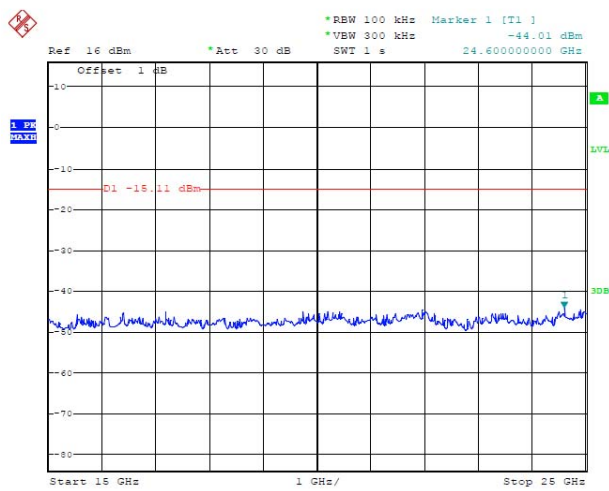

15GHz~25GHz

Test Mode:

802.11b

Test channel :

6

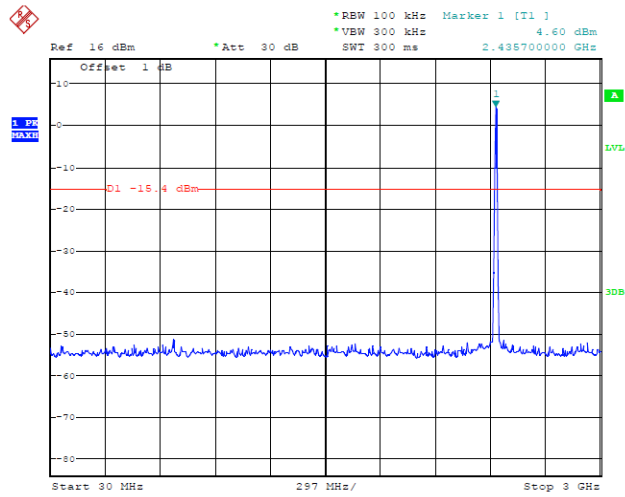

30M Hz~3GHz

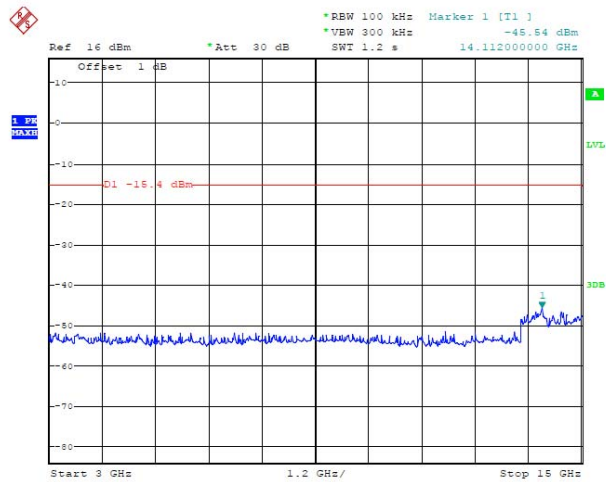

3G Hz~15GHz

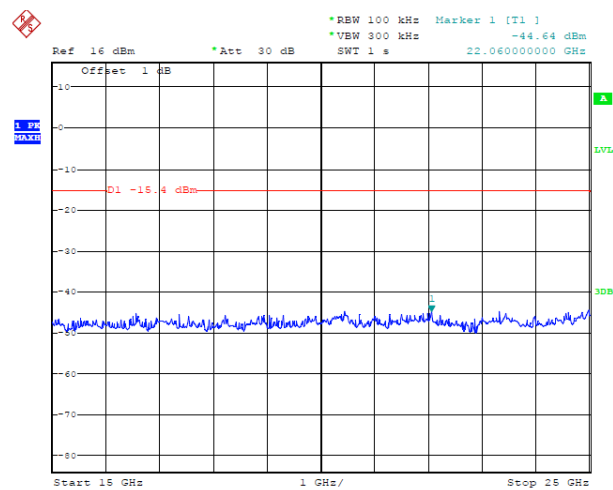

15GHz~25GHz

Test Mode:

802.11b

Test channel :

11

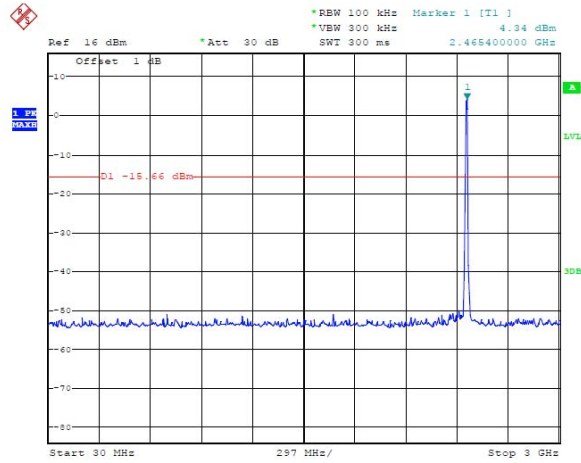

30M Hz~3GHz

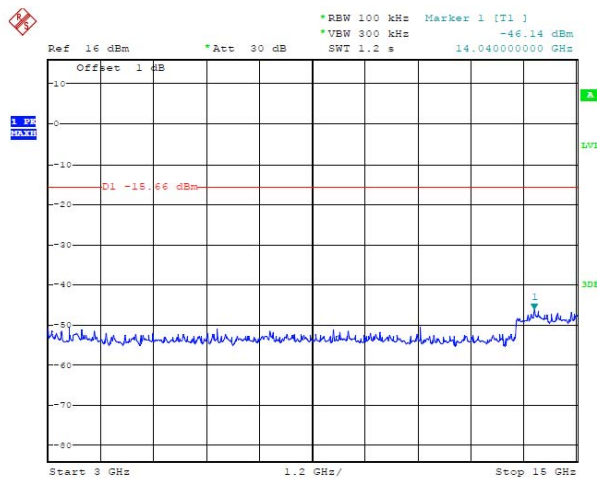

3G Hz~15GHz

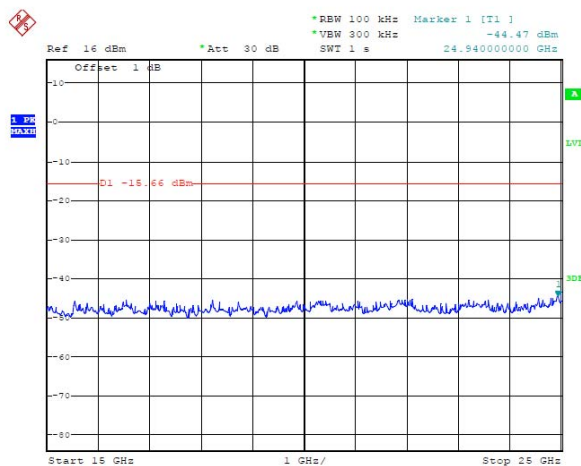

15GHz~25GHz

Test Mode:

802.11g

Test channel :

1

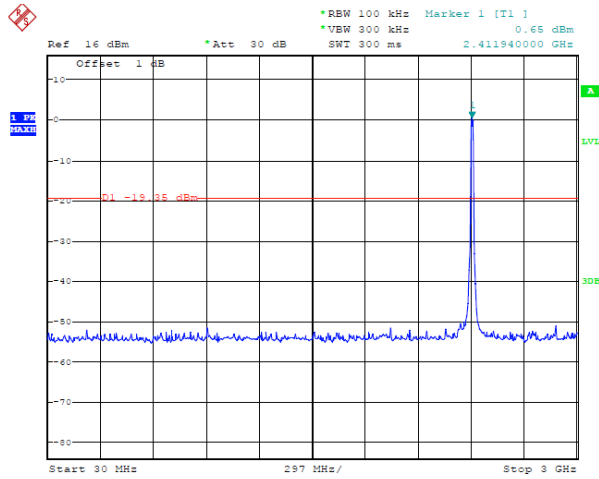

30M Hz~3GHz

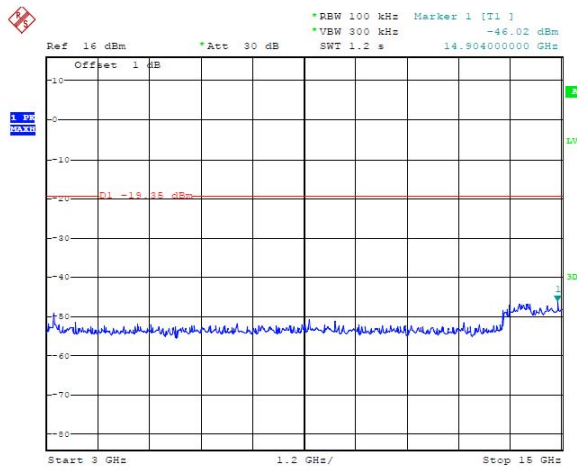

3G Hz~15GHz

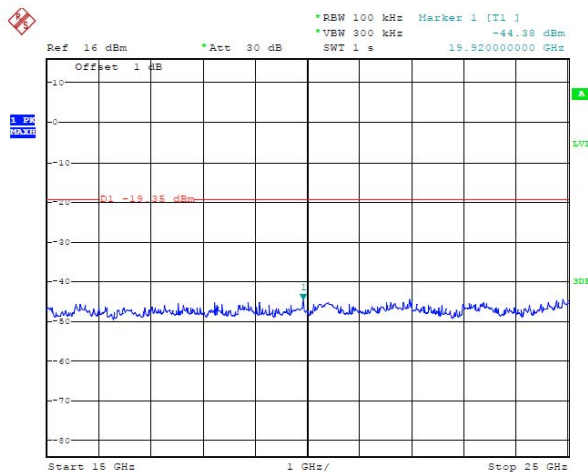

15GHz~25GHz

Test Mode:

802.11g

Test channel :

6

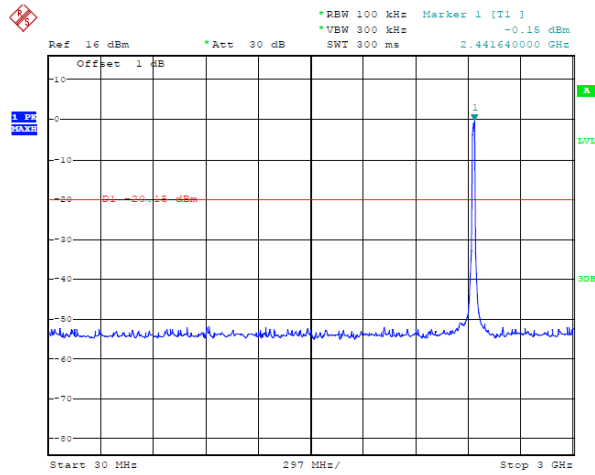

30M Hz~3GHz

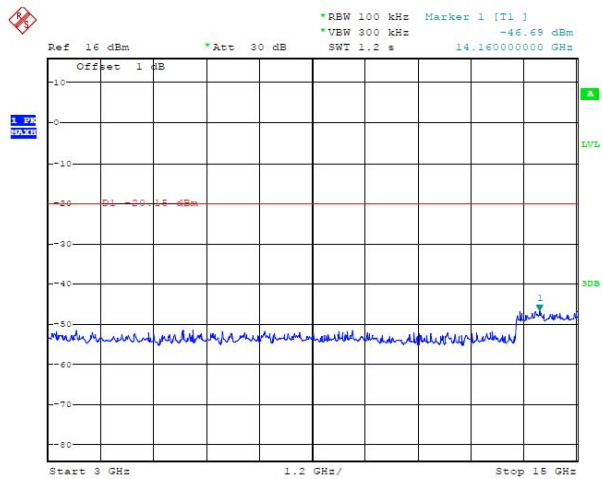

3G Hz~15GHz

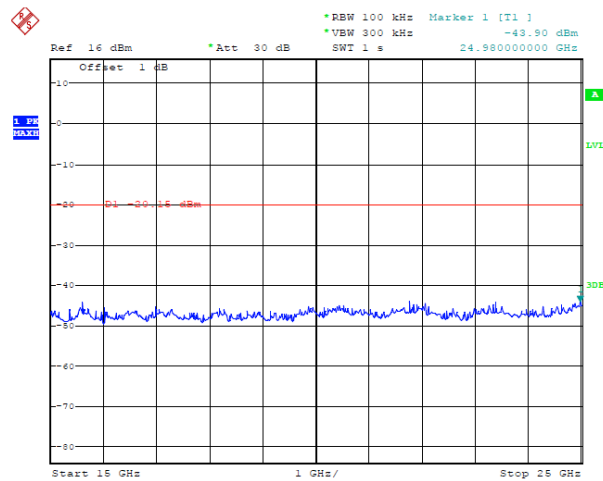

15GHz~25GHz

Test Mode:

802.11g

Test channel :

11

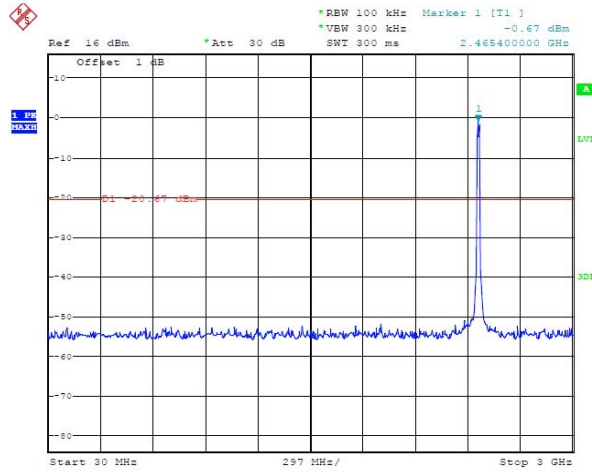

30M Hz~3GHz

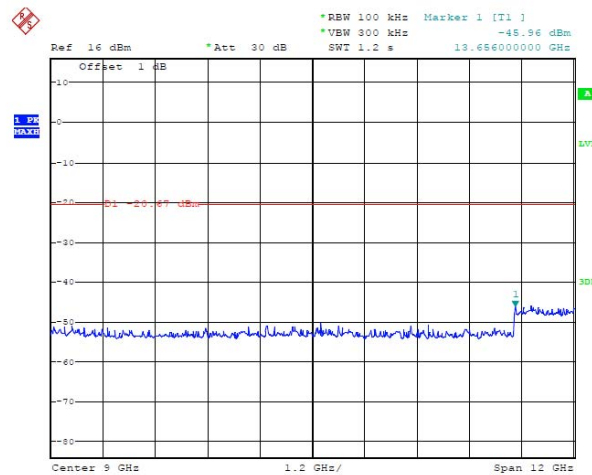

3G Hz~15GHz

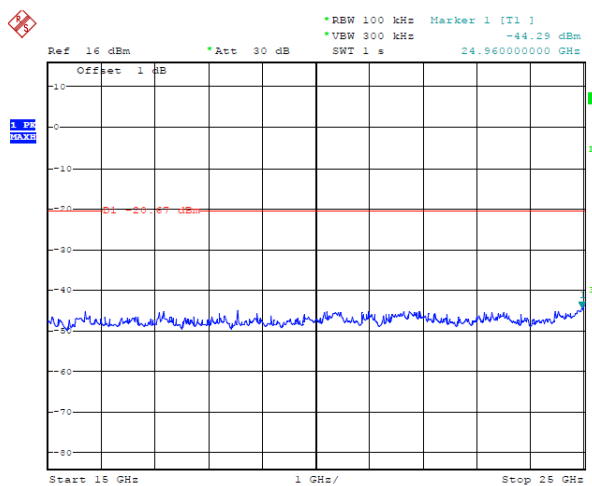

15GHz~25GHz

Test Mode:

802.11 n HT20

Test channel :

1

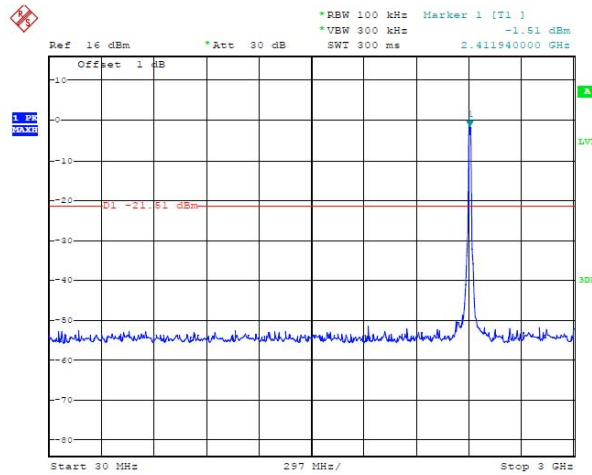

30M Hz~3GHz

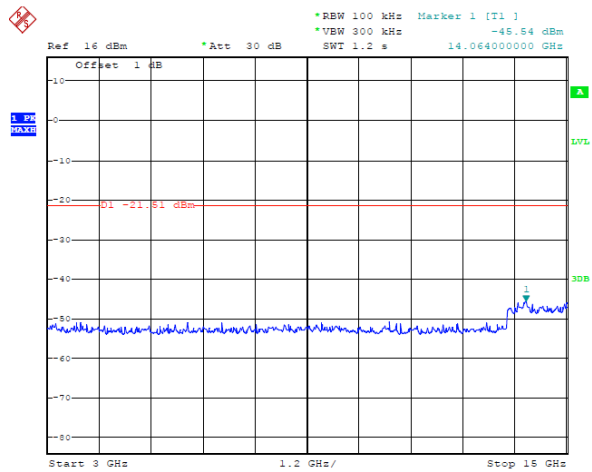

3G Hz~15GHz

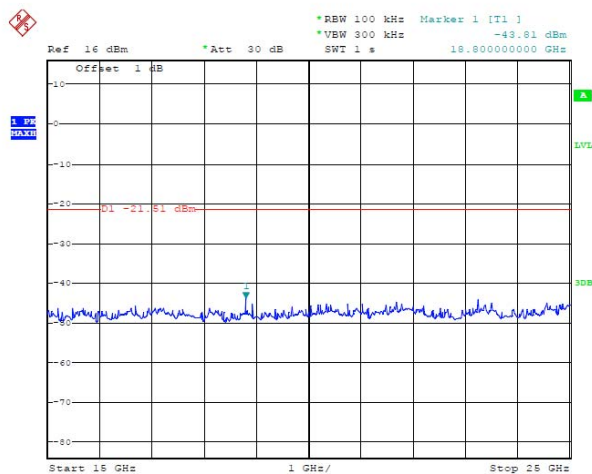

15GHz~25GHz

Test Mode:

802.11 n HT20

Test channel :

6

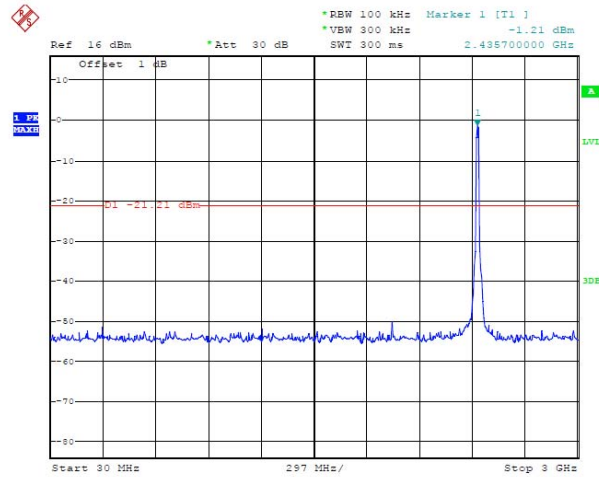

30M Hz~3GHz

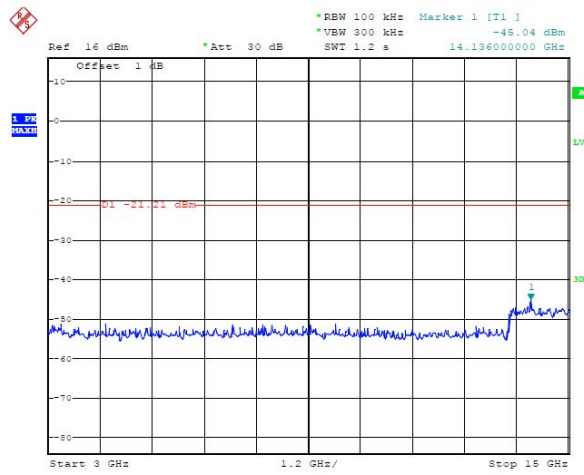

3G Hz~15GHz

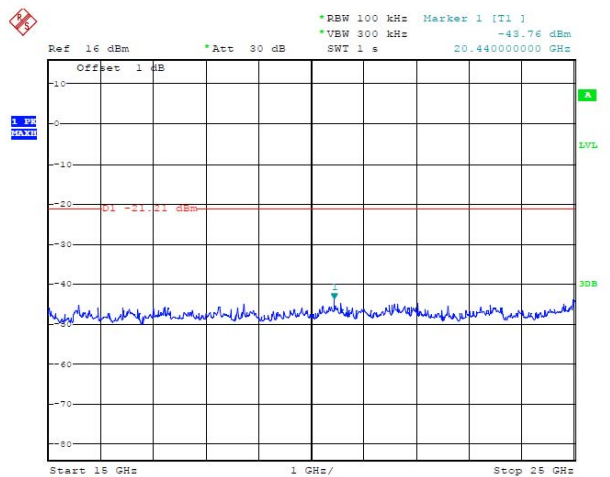

15GHz~25GHz

Test Mode:

802.11 n HT20

Test channel :

11

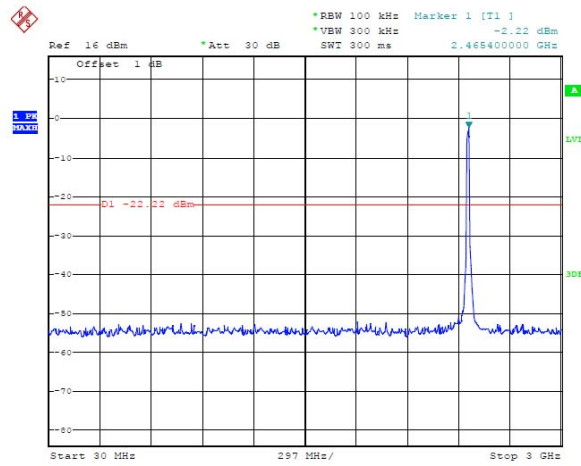

30M Hz~3GHz

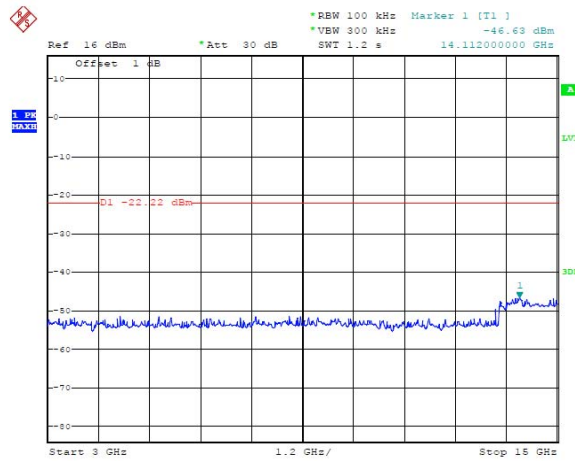

3G Hz~15GHz

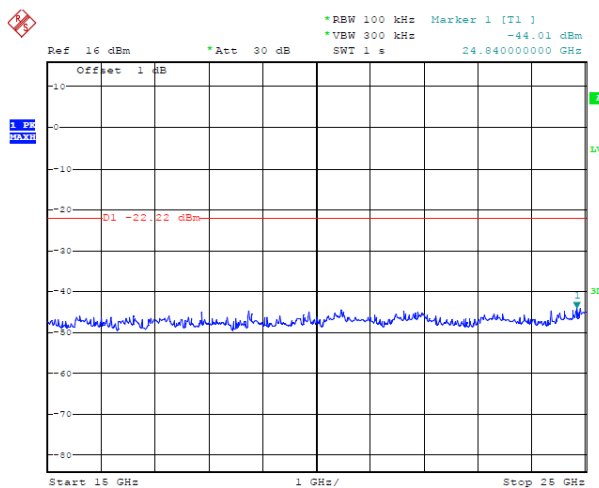

15GHz~25GHz

Test Mode:

802.11 n HT40

Test channel :

3

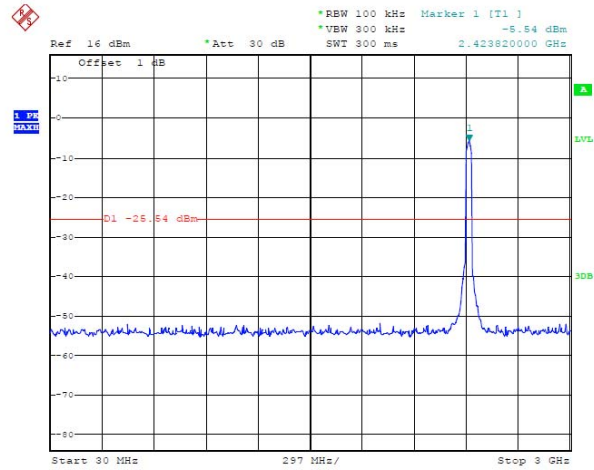

30M Hz~3GHz

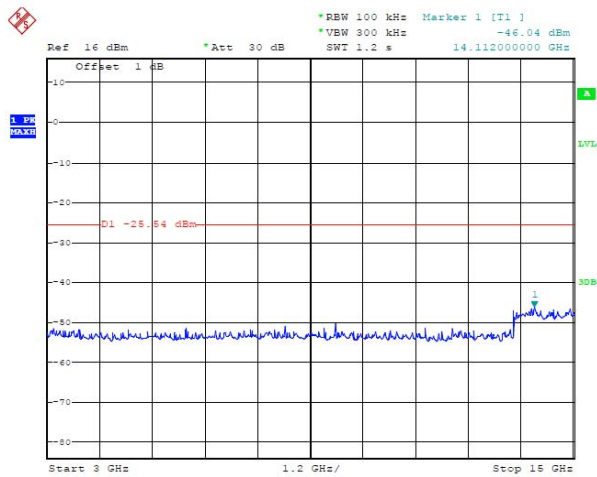

3G Hz~15GHz

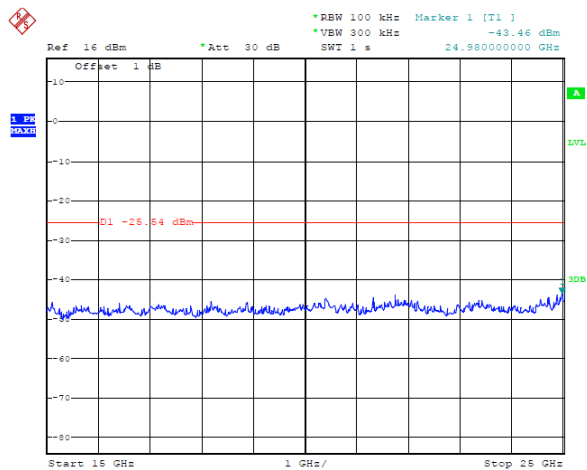

15GHz~25GHz

Test Mode:

802.11 n HT40

Test channel :

6

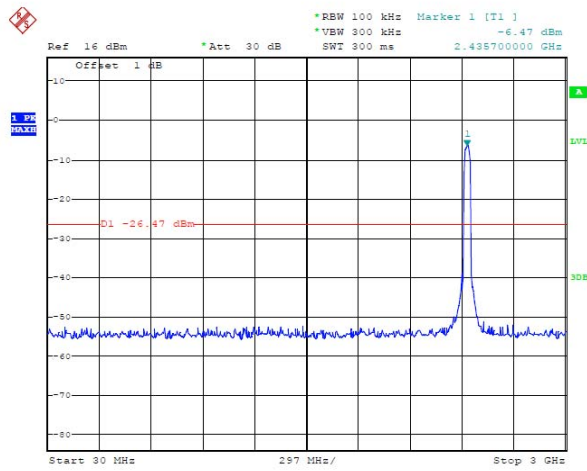

30M Hz~3GHz

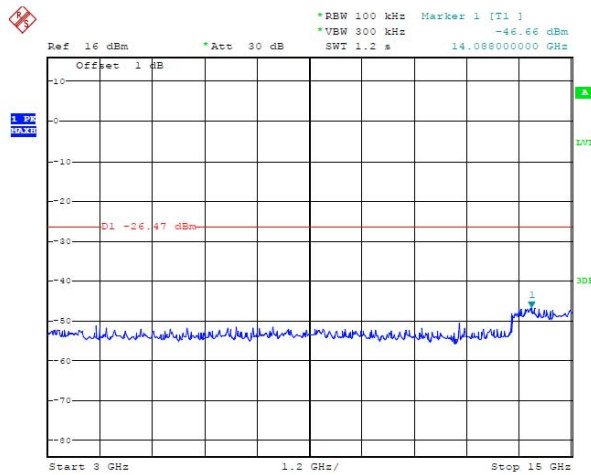

3G Hz~15GHz

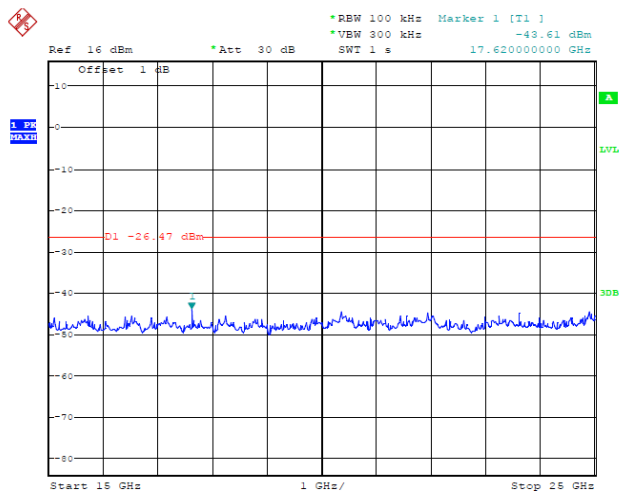

15GHz~25GHz

Test Mode:

802.11 n HT40

Test channel :

9

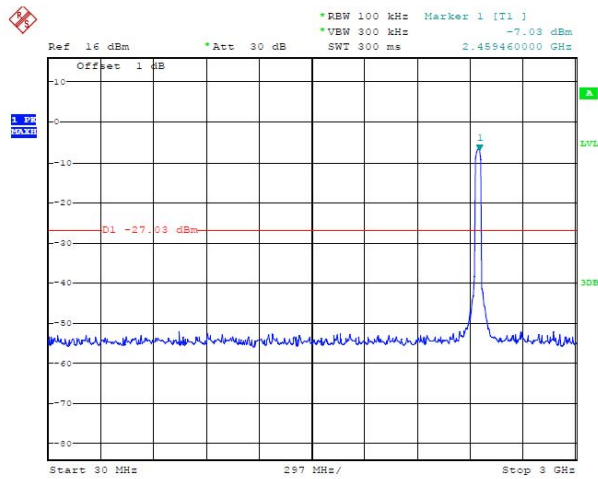

30M Hz~3GHz

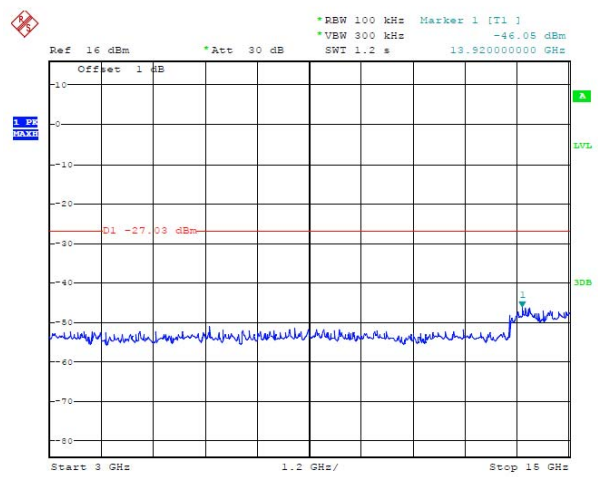

3G Hz~15GHz

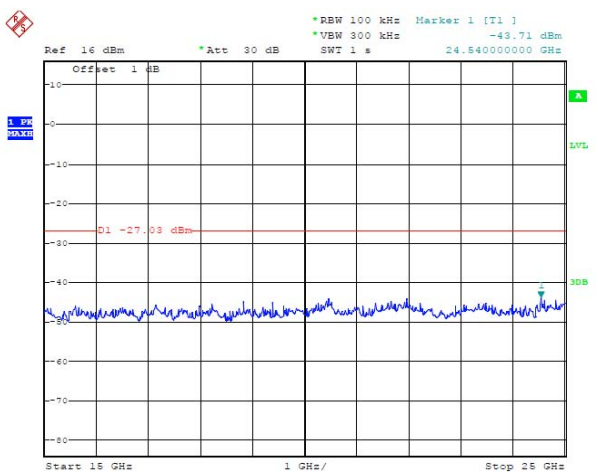

15GHz~25GHz

4.8. Antenna Requirement

Standard Applicable

For intentional device, according to FCC 47 CFR Section 15.203, an intentional radiator shall be designed to ensure that no antenna other than that furnished by the responsible party shall be used with the device.

And according to FCC 47 CFR Section 15.247 (c), if transmitting antennas of directional gain greater than 6dBi are used, the power shall be reduced by the amount in dB that the directional gain of the antenna exceeds 6dBi.

Refer to statement below for compliance.

The manufacturer may design the unit so that the user can replace a broken antenna, but the use of a standard antenna jack or electrical connector is prohibited. Further, this requirement does not apply to intentional radiators that must be professionally installed.

Measurement

The antenna gain of the complete system is calculated by the difference of radiated power in EIRP and the conducted power of the module. For normal WLAN devices, the DSSS mode is used.

Conducted power refer ANSI C63.10 :2009 Section 11.9 Output power test procedure for DTS devices

Radiated power refer to ANSI C63.10 :2009 Section 6.6.4 Radiated emissions tests.

Measurement parameters

Measurement parameter	
Detector:	Peak
Sweep time:	Auto
Resolution bandwidth:	1MHz
Video bandwidth:	3MHz
Trace-Mode:	Max hold

Limits

Antenna Gain	6 dBi
--------------	-------

Results

T_{nom}	V_{nom}	Lowest Channel 2412 MHz	Middle Channel 2437 MHz	Highest Channel 2462 MHz
Conducted power [dBm] Measured with DSSS modulation		6.56	6.24	6.31
Radiated power [dBm] Measured with DSSS modulation		5.17	5.78	4.93
Gain [dBi] Calculated		-1.39	-0.46	-1.38
Measurement uncertainty		± 0.6 dB (cond.) / ± 4.32 dB (rad.)		

5. Test Setup Photos of the EUT

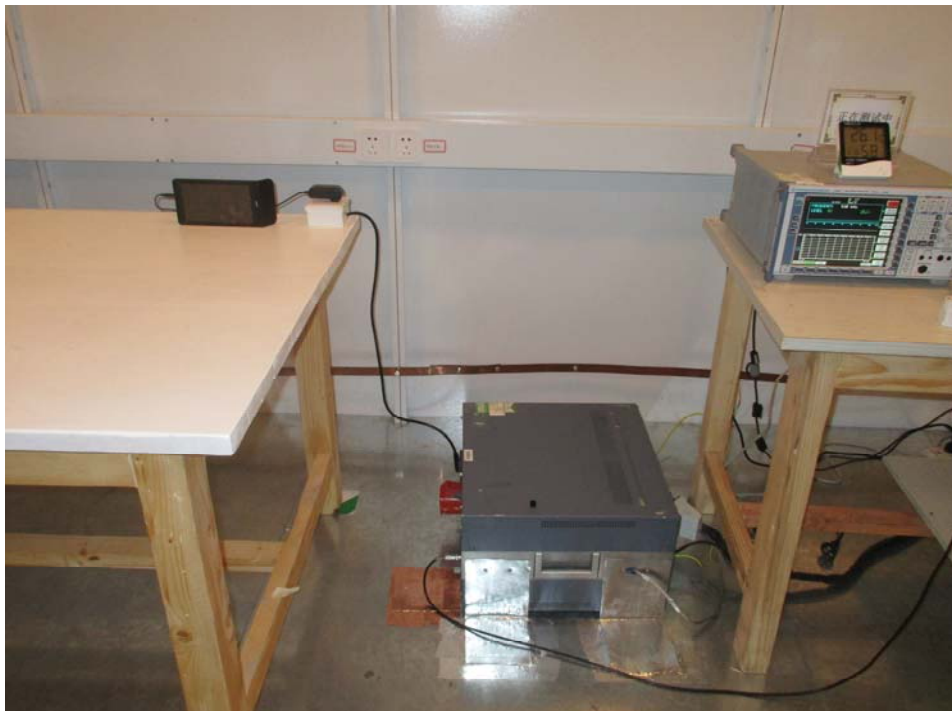
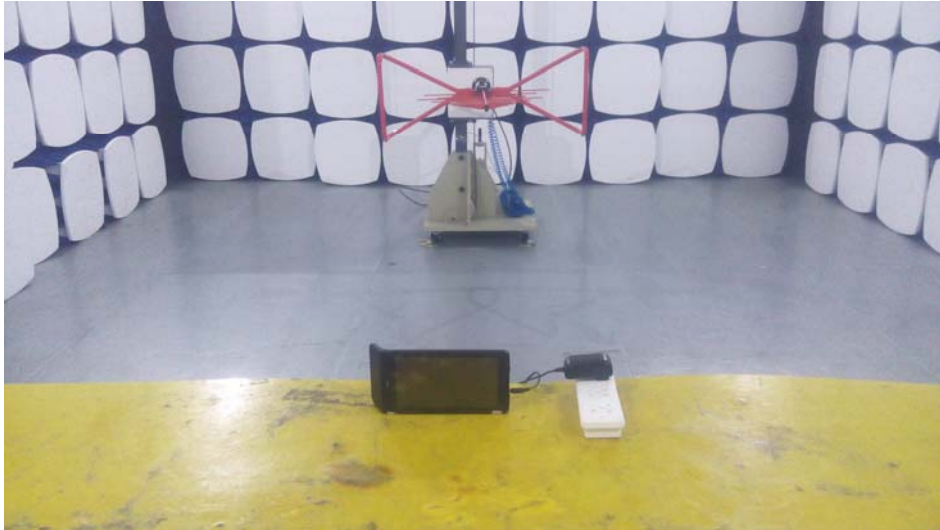

6. External and Internal Photos of the EUT

External Photos





Internal Photos



WLAN Antenna



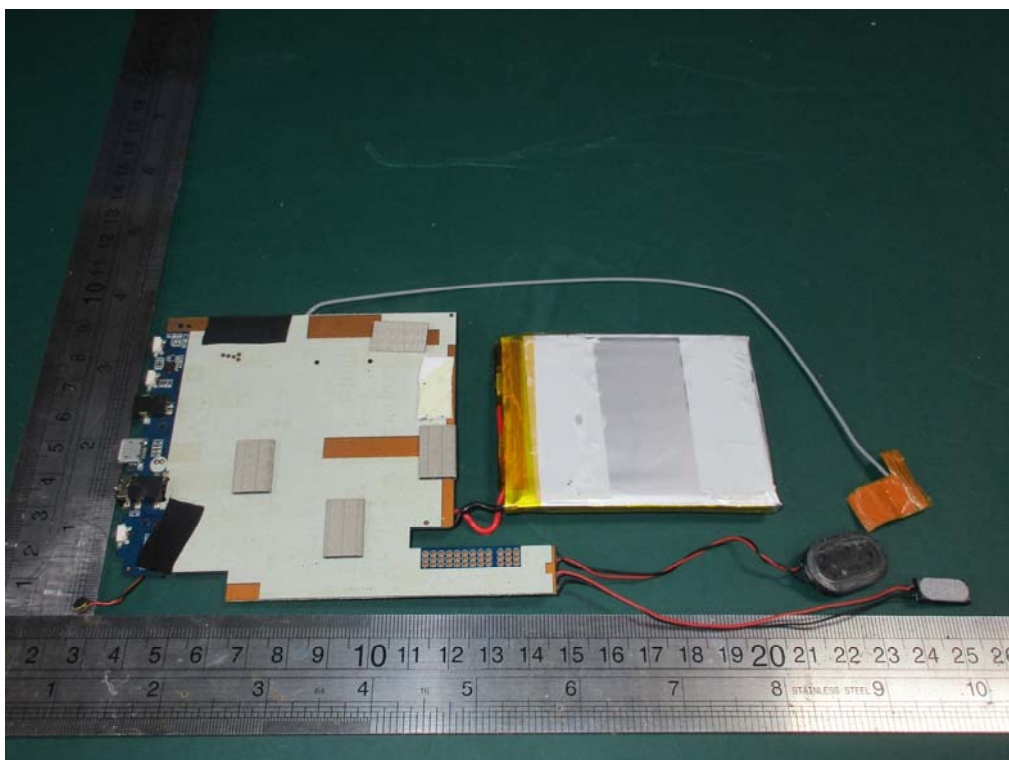
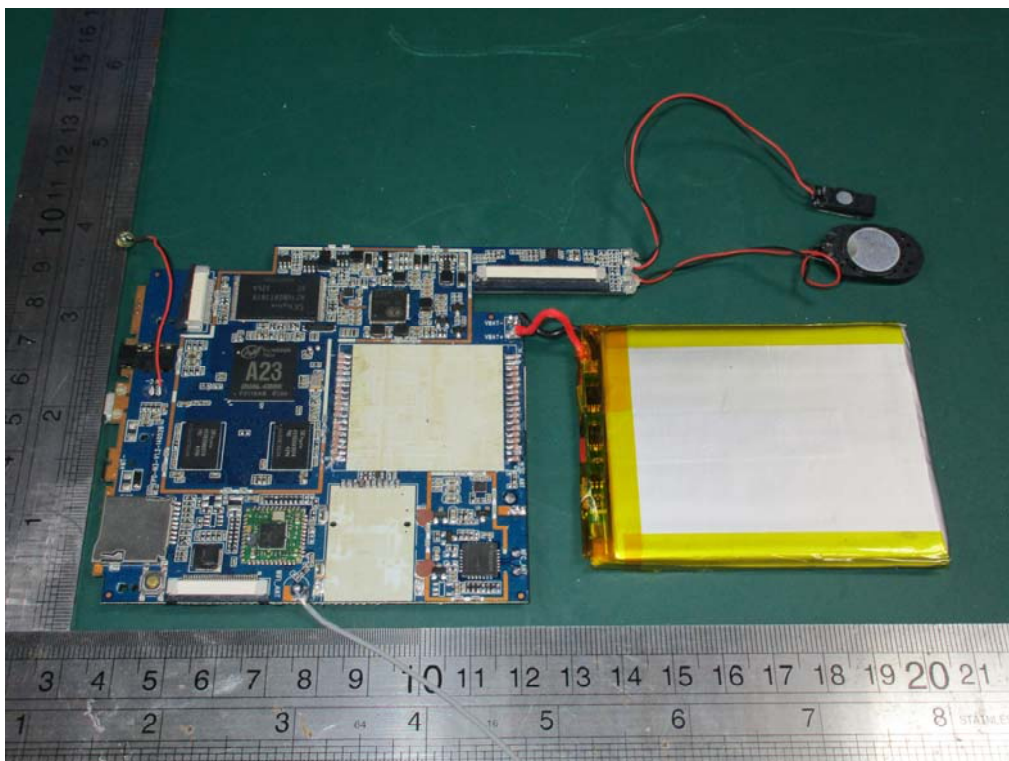

.....End of Report.....