

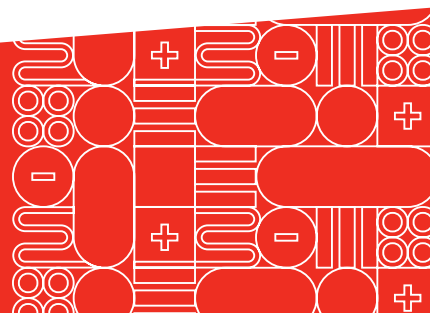

Eliko RTLS Installation Guide

Tallinn 2021

SENSING
THE FUTURE™





CONTENTS

DOCUMENT SCOPE AND PURPOSE.....	3
TERMINOLOGY	3
1. SYSTEM COMPONENTS AND CONNECTIVITY	4
2. ANCHOR INSTALLATION	6
a. Anchor coordinate measurement.....	7
b. Correction factors for anchor coordinates	7
3. ELIKO RTLS SERVER SETUP	9
a. Starting up the Eliko RTLS server	9
b. Anchor's Network.....	9
c. Client's Network.....	9
d. Wi-Fi network	9
4. CONNECTING TO THE ELIKO RTLS MANAGER	9
a. Wi-Fi enabled laptop.....	9
b. Cable-based ethernet connection via Anchor network port	10
c. Connect a PC directly to Client network port.....	10
5. ELIKO RTLS ANCHOR AND TAG FEEDBACK.....	10
6. CLIENT NETWORK	12
7. ELIKO RTLS MANAGER	12
a. Layout plan	12
b. Anchors list	13
c. Tags list.....	14
d. Dashboard	15
8. CLIENT SOFTWARE INTEGRATION	16
9. TURNING OFF THE SYSTEM	16



DOCUMENT SCOPE AND PURPOSE

This installation guide is designed to help users install the Eliko RTLS system.

TERMINOLOGY

GUI – Graphical User Interface

LoS – Line of sight

NLoS – Non-line of sight

PoE – Power over Ethernet

RTLS – Real-Time Location System

UWB – Ultra-Wideband



1. SYSTEM COMPONENTS AND CONNECTIVITY

The Eliko RTLS consists of:

- Eliko RTLS Anchors – Anchors can be used in two different configurations:
 - Anchors in standard configuration use a Power over Ethernet (PoE) connector for both power and data transmission (note: anchors can also be powered by micro-USB, and Ethernet can be used for data transmission only). All Ethernet cables starting with cat 5 are compatible with the Eliko RTLS system. Eliko recommends using 8 core Ethernet cables.
 - Anchors in Wi-Fi configuration use internal Wi-Fi modules for data transmission and are meant for temporary setups or for installations where drawing cables is complicated. Anchors in Wi-Fi configuration must be powered with micro-USB cables or PoE injectors.
- Eliko RTLS Tags – Tags communicate with anchors over UWB and measure the distances on which the coordinate calculations are based. The tags are battery powered and can be charged or be powered by an external source such as a forklift.
- Eliko RTLS Server – the Eliko RTLS Server is an Ubuntu Linux machine with multiple roles. It creates the RTLS anchor network, calculates coordinates, connects the Eliko RTLS with any third-party information system and hosts the Eliko RTLS Manager.
- Eliko RTLS Manager – Graphical user interface (GUI) for system setup, configuration and visualisation.

Optionally used for setting up the system:

- PoE Switch – The switch is necessary in a standard setup in which case all anchors must be connected to the switch via ethernet cables. The switch transfers data from the anchors to the Eliko RTLS Server and powers the anchors.
- PoE Extender – The PoE Extender is a convenient way to extend the network by using a switch that is powered by a PoE port. Instead of drawing cables to each anchor separately, a PoE extender can be used to draw one cable to the extender and draw cables from the extender to the anchors. The extender transfers data from the anchors to the Eliko RTLS Server and powers the anchors.
- Wi-Fi repeater – The Wi-Fi repeater is useful if the distance to the Eliko RTLS server is longer than 90 m or there are obstructions that do not allow Wi-Fi connection to the anchors. If you are using your local Wi-Fi network, then using Wi-Fi repeaters is not needed because the anchors can be configured to communicate through the local Wi-Fi network to the server.
- USB charging dock – USB charging dock to charge the tags and update multiple devices at the same time.

Contact Eliko for additional consultation for other connectivity options.

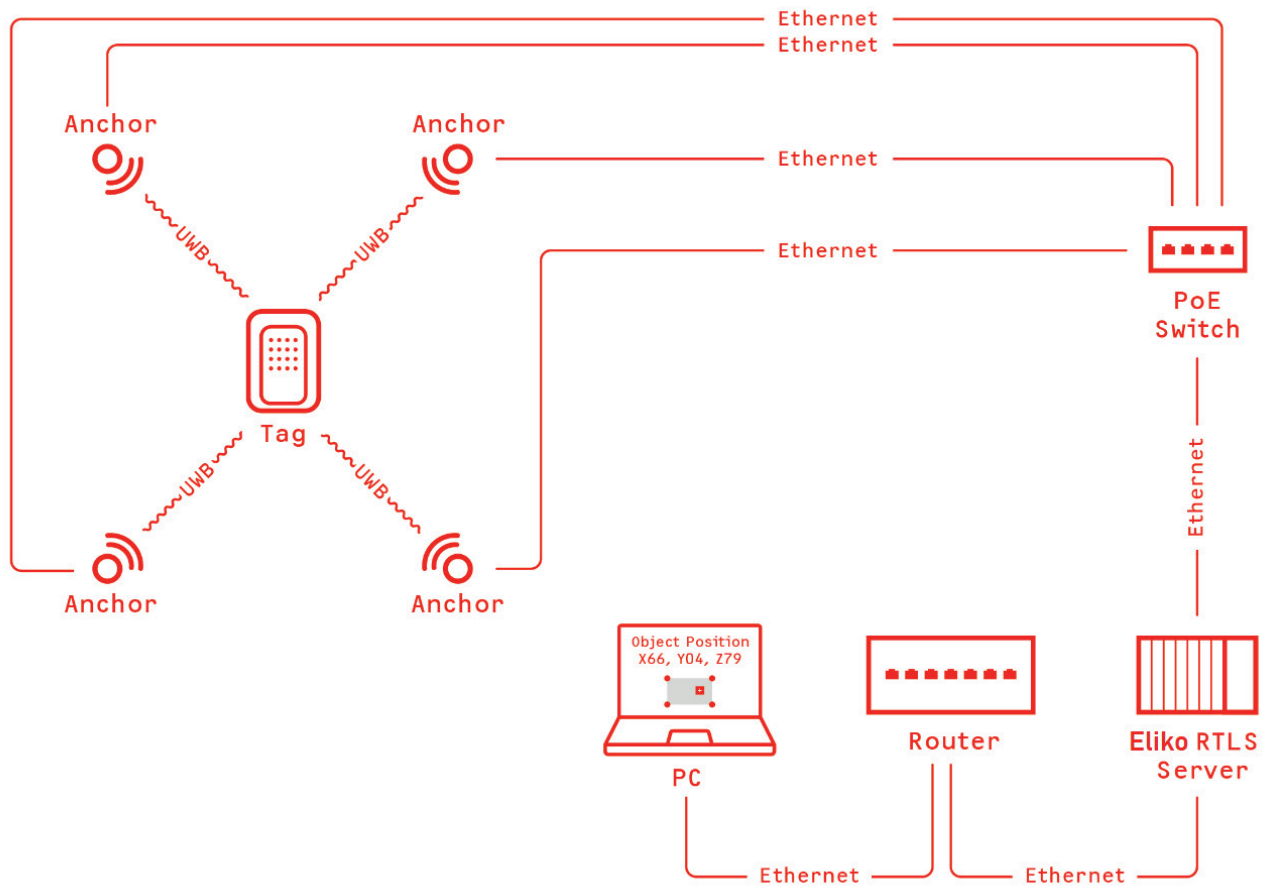

Figure 1. A small-scale Eliko RTLS network with ethernet connectivity.

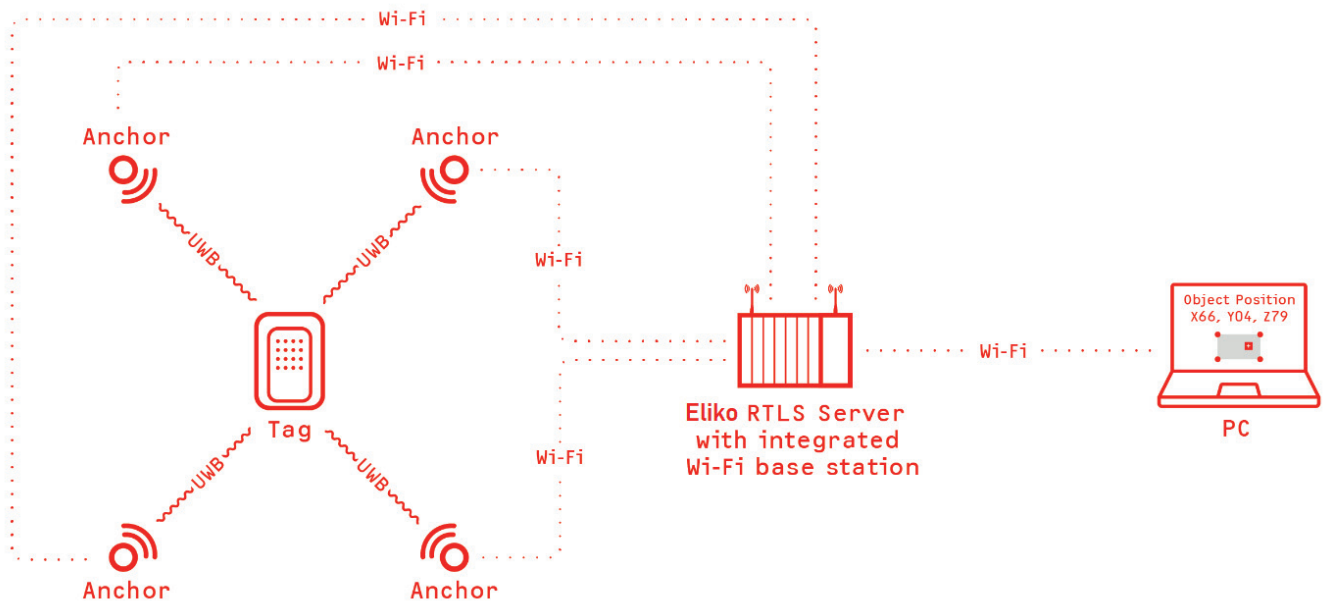

Figure 2. A small-scale Eliko RTLS network with Wi-Fi connectivity.



2. ANCHOR INSTALLATION

In order to cover the entire tracking area, it is usually best to install the anchors at an elevated position, misaligned and close to the edges of the tracking area (but not in the corners). In special rooms, such as corridors, the anchors should be placed using a trapezoid or rhombus pattern.

The anchors should be placed on the wall using Eliko RTLS wall mounts (see Figure 5).. The wall mounts have moving heads that you can use to adjust the anchor position. The anchors can be positioned in any direction on the wall or even upside down when attached to the ceiling. Make sure there

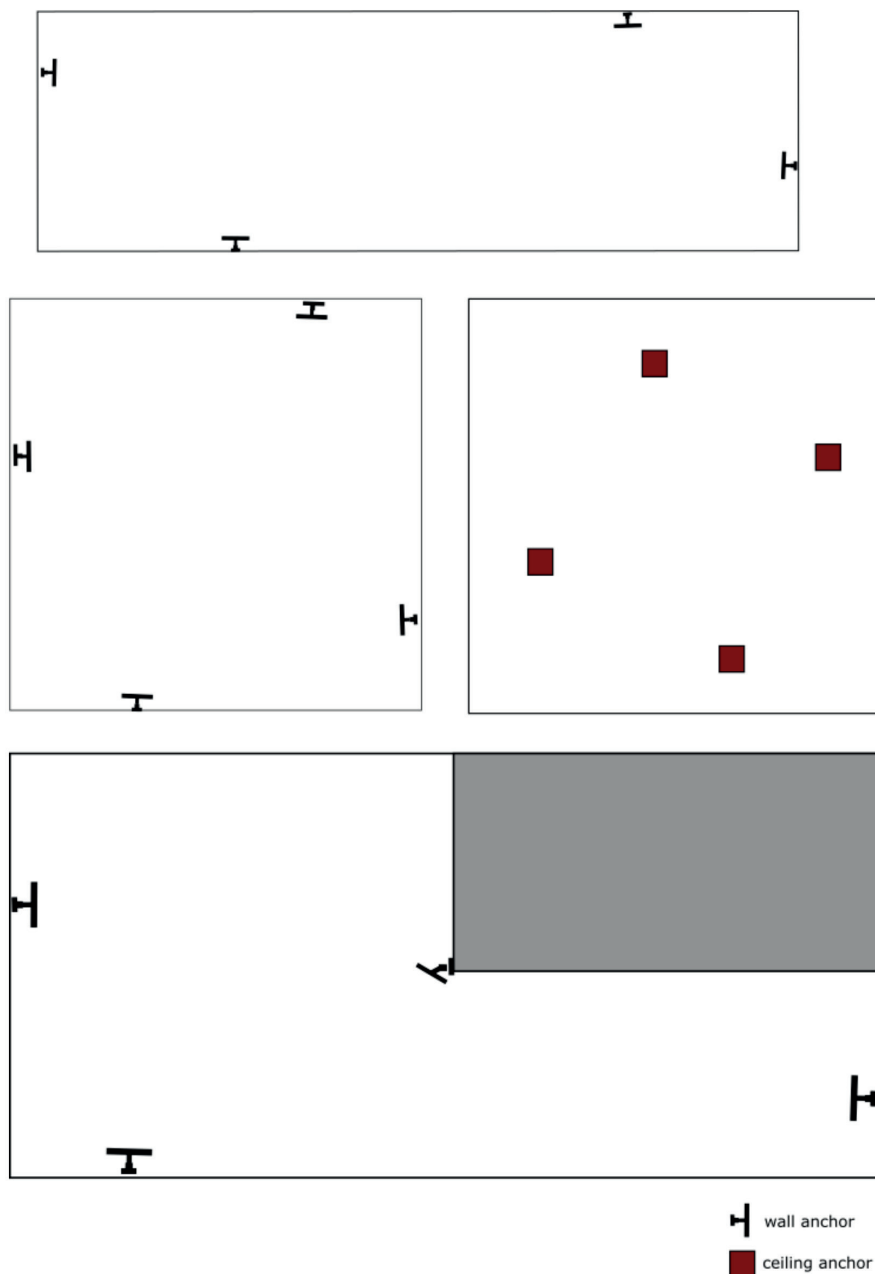

Figure 3. Best practices for different rooms/areas.



are no objects close to the anchors blocking the LoS. Although the performance of the anchor is very similar in all directions, in more difficult scenarios it is recommended that the anchor side with the Ethernet port faces the direction of least interest. In square-shaped rooms it is best to mount anchors to the ceiling as displayed in Figure 3; if this is not possible, then use the alternative option displayed in Figure 3. When anchors are mounted to the ceiling, they do not need to be horizontal with the ceiling. Please note, anchors should be always installed in locations where they are at least 20 cm away from the users.

NB! When using 3D features we recommend 6 anchors.

For 3D setup, there is no straightforward practice for getting the best results, and there is a lot more to take account of. Every tracking area should be investigated separately. Therefore, we recommend contacting our customer support when there is a need for 3D features.

Contact Eliko for additional help in determining the exact anchor locations.

a. Anchor coordinate measurement

The Eliko RTLS needs you to turn your physical surroundings into a XYZ-space in order to determine the accurate anchor locations. The anchor locations must be measured very accurately. Any inaccuracies will adversely affect the overall accuracy of the tag positioning coordinates. First, determine a point in your tracking area that will be your zero-coordinate point in the X- and Y-axes (0;0). This reference point is how you identify the location of all the anchors. For example, if your tracking area has perpendicular, straight walls that can act as X- and Y-axes, then your reference point is the corner of the intersection of these two.

Measure the coordinates relative to the tracking area zero point for all of the anchors. Even if you track objects only in 2D (the XY-plane), it is important to measure the Z-coordinate of the anchors as well. Usually, this is the height of the anchors from the tracking area floor.

Coordinates can be measured manually with a simple tape measure or a hand-held laser distance meter. However, we recommend using professional land surveyor services for the most accurate results, especially in large-scale setups.

NB! Mark down the anchor serial numbers before fixing them on the walls. You will need the serial numbers later when you insert the coordinates into the Eliko RTLS Manager.

Contact Eliko for additional help in measuring the anchor locations.

b. Correction factors for anchor coordinates

Since anchors are physical three-dimensional objects, they have their own local zero-coordinate points. The distance from an anchor to a tag is measured between the antennas located inside of each device's casings. The antennas inside the anchors have fixed coordinates relative to the symbol on the front side of the anchor (Figure 4). The correction factors for determining the precise location of the anchor are: 0 mm for the X-axis, 15 mm for the Y-axis and 36 mm for the Z-axis.

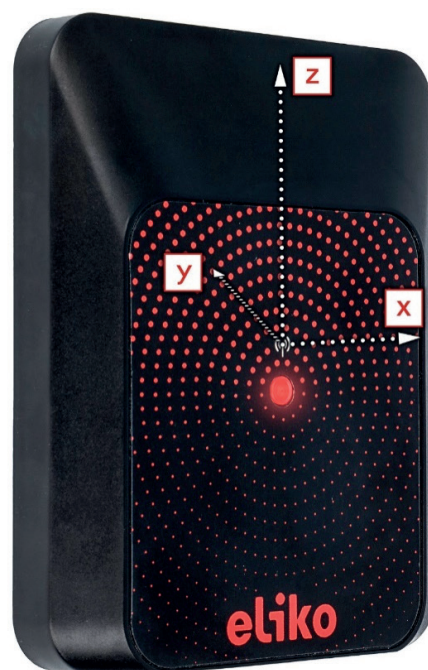

Figure 4. Local coordinate system for the anchors.



NB! The coordinate axes displayed in Figure 4 don't necessarily match with the overall coordinate system. The correction factors should be used only for very accurate (less than 50 cm) anchor coordinate measurements. Otherwise, they can be ignored.

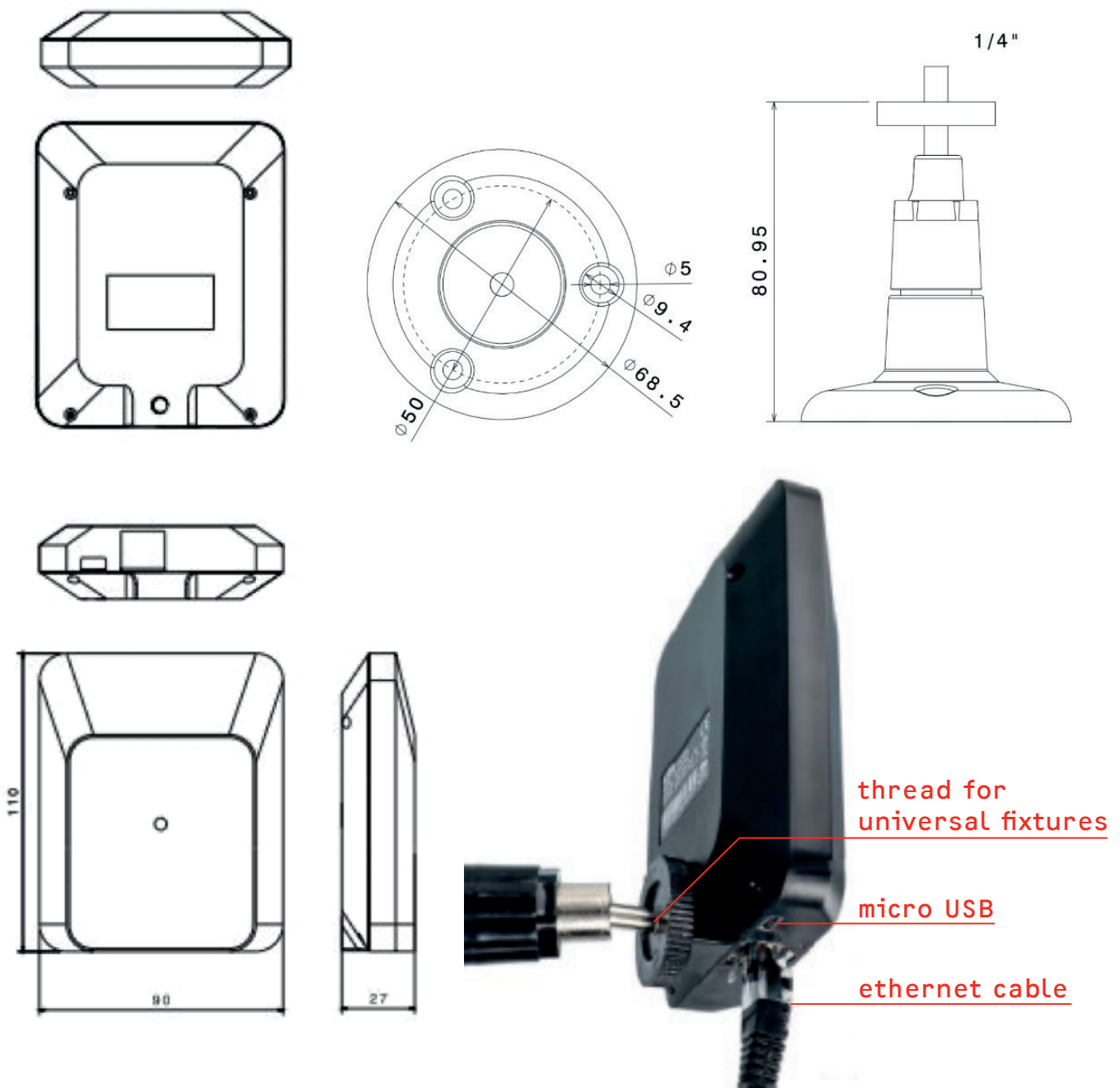

Figure 5. Eliko anchor and anchor mount



3. ELIKO RTLS SERVER SETUP

a. Starting up the Eliko RTLS server

The Eliko RTLS Server is an Ubuntu Linux machine with dual ethernet interfaces – one for the anchor network (Anchor's Network) and the other for integration with the client's system (Client's Network). Additionally, the RTLS Server includes an optional integrated Wi-Fi module, so connections to the RTLS anchors and/or to the client's application logic may also be done wirelessly.

NB! Before power-up, attach Wi-Fi antennas to the server. If there are no Wi-Fi antennas with the server, then the server does not have Wi-Fi.

After attaching the Wi-Fi antennas, connect the anchors to the Anchor's Network port, and after that connect the server's Client Network port with the local network router.

After this, you can plug in the server into the power supply. Press the power button to start the server. Wait for a couple of minutes for all of the anchors to come online. A blinking LED light indicates that the anchor has been powered.

b. Anchor's Network

On the Anchor's Network, the RTLS Server runs a DHCP server and leases IP addresses

for everyone that asks for it. In the most common case, a PoE switch is connected to Anchor's Network port of the RTLS Server. The anchors will be connected to the PoE switch. The RTLS anchors, PoE switch(es), optional additional ethernet switches and cables make up the RTLS anchor network.

c. Client's Network

The RTLS Server has another ethernet port called the Client's Network, which is meant for connecting the RTLS Server to the client's network. The Client's Network is configured to ask for an IP address from an external DHCP server residing in the client's network. It is the responsibility of the Client's Network administrator to configure their DHCP server in a way that it leases an IP address for the RTLS Server.

d. Wi-Fi network

Additional to the cable-based Anchor's Network and Client's Network connections, the RTLS Server includes an integrated Wi-Fi module. The RTLS Server's Wi-Fi network is logically connected to Anchor's Network, so everyone connecting with this Wi-Fi obtains an IP address, leased by the DHCP server running on the RTLS Server.

4. CONNECTING TO THE ELIKO RTLS MANAGER

There are three options to access the Eliko RTLS Manager web interface:

a. Wi-Fi enabled laptop

- For connecting a Wi-Fi enabled laptop, which is located close enough to the RTLS Server, the easiest way is using the wireless network provided by the RTLS Server. The name of this network may be Eliko-RTLSS-BS-XXXX, KIORTLSS-BS-XXXX or KIORTLSS-AP-XXXX, where XXXX is a 4-digit number which is unique among all the RTLS Servers. Just

look this network up on your laptop and create a connection to it. This connection is protected by a password, which you can find as a sticker on the bottom of the RTLS Server. Please note that on some operating systems, the laptop will assume it gets internet access through this Wi-Fi connection, which is not true. After clicking "connect" on the laptop, it may be shown for quite a long time that establishing the connection is still in progress, while the connection is actually created with a couple of seconds. This means it would be okay to verify the



connection just a couple of seconds after clicking the "connect" button, without waiting for the progress indicator to finish. When connected via Wi-Fi, you can access the Eliko RTLS Manager web interface by using your web browser to access the following URL: <http://10.8.4.1>

b. Cable-based ethernet connection via Anchor network port

For a cable-based ethernet connection, the easier way is to connect the PC behind the Anchor's Network and leave the Client's Network unused. The PC should be configured to obtain an IP address from an external DHCP server (this configuration may already be the default one). If the RTLS anchors are connected via Wi-Fi, the Anchor's Network port of the RTLS Server is empty and a simple ethernet cable may be used to connect the PC. If the Anchor's Network port is already occupied by a network switch, then the PC should be connected behind any switch residing in the Anchor's Network. Note that PoE functionality is not required for connecting the PC, so you can also use

a non-PoE port for this connection. For this cable-based connection, there is no password to access the Eliko RTLS Manager web interface. You can just use your browser to access the following URL: <http://10.8.4.1>

c. Connect a PC directly to Client network port

It is also possible to connect a PC directly to the Client's Network port, but this may be more complicated to configure. The Client's Network interface expects an external DHCP server to lease an IP address to the RTLS Server. With the current case, the client's PC should have a DHCP server running for this purpose. When connecting via the Client's Network port, you can't access the same URL as mentioned in the previous options. You need to use the admin panel of your DHCP server to find the IP address it has leased to the RTLS Server. You can then access the RTLS Manager web interface by using your web browser and this IP address as the URL.

Contact ELIKO for additional consultation for other connectivity options

5. ELIKO RTLS ANCHOR AND TAG FEEDBACK

Both the anchors and the tags are equipped with an LED light on the front side of the device. This is used as a feedback indicator to give the user information about the device's status. The following tables describe the different combinations for the LED colour and interval.

The Eliko RTLS anchors are automatically turned on when they are connected to a power supply (either by an ethernet cable connected to a PoE switch or by a micro-USB adapter). To restart the anchor, just unplug it from the power supply for a few seconds.

The Eliko RTLS tags have an on/off button. Hold the button for 2 seconds to turn it on. A white LED fade-in followed by a blinking light indicates that the tag is online. To turn it off, hold the button again for 2 seconds. A white LED fade-out appears and the blinking stops – now the tag is offline. A quick press (less than a second) will restart the tag.



Table 1. Different statuses of the anchor and the corresponding LED statuses.

LED colour	LED interval	Indication description
Green	Blinking	Device is powered and in range of tags
Yellow	Blinking	Device is powered, no tags in range
Red	Blinking	Hardware/software error. If restarting the anchor doesn't work please contact Eliko



Figure 6. The Eliko Tag.

Table 2. Different statuses of the tag and the corresponding LED indications.

LED colour	LED interval	Indication description	USB status
White	Fade-in	Device start up	Either
White	Fade-out	Device shut down	Either
Green	On	Battery full	Connected
Yellow	On	Battery charging	Connected
Green	Blinking	In range – OK	Disconnected
Yellow	Blinking	No valid anchors responding	Disconnected
Red	On	Battery empty, connect charger	Disconnected
Red	Blinking	Hardware/software error. If restarting the tag doesn't work please contact Eliko	Either



6. CLIENT NETWORK

If you connect the Eliko RTLS Server's "Client Network" port to your company's network router, you need to make sure your network has a DHCP server running. After the Eliko RTLS Server has obtained an IP address from your network, you must identify this address. Usually, this can be done by accessing the admin page of your net-

work router. Look up the Eliko RTLS Server IP address under the name "KIO-RTLSS". The Eliko RTLS Manager can be accessed from your network by using a web browser to access a URL like `http://10.10.10.10` (replace 10.10.10.10 with the IP address your network has leased for the Eliko RTLS Server).

7. ELIKO RTLS MANAGER

Go to the previously obtained server IP address to access the Eliko RTLS Manager using any browser. Read and accept the

Eliko RTLS EULA. Now you are ready to start configuring the system.

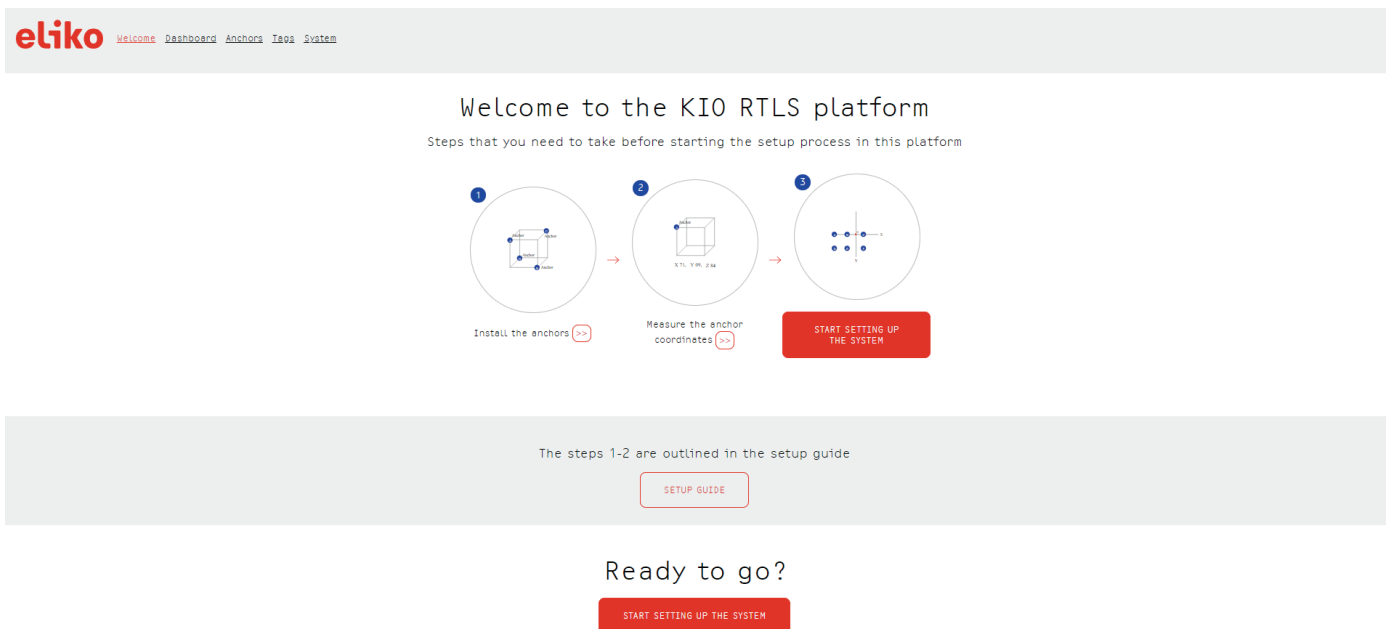

Figure 7. View of the Eliko RTLS Manager front page.

a. Layout plan

Click the "Start setting up the system" button on the "Welcome" page. You can see the "Plan configuration" panel on the right side of the page and an interactive window on the left. You can start by uploading the

plan image. If you don't want to use plan at the moment, you can just click the "Set Anchors" button to move forward to the anchor's configuration page.

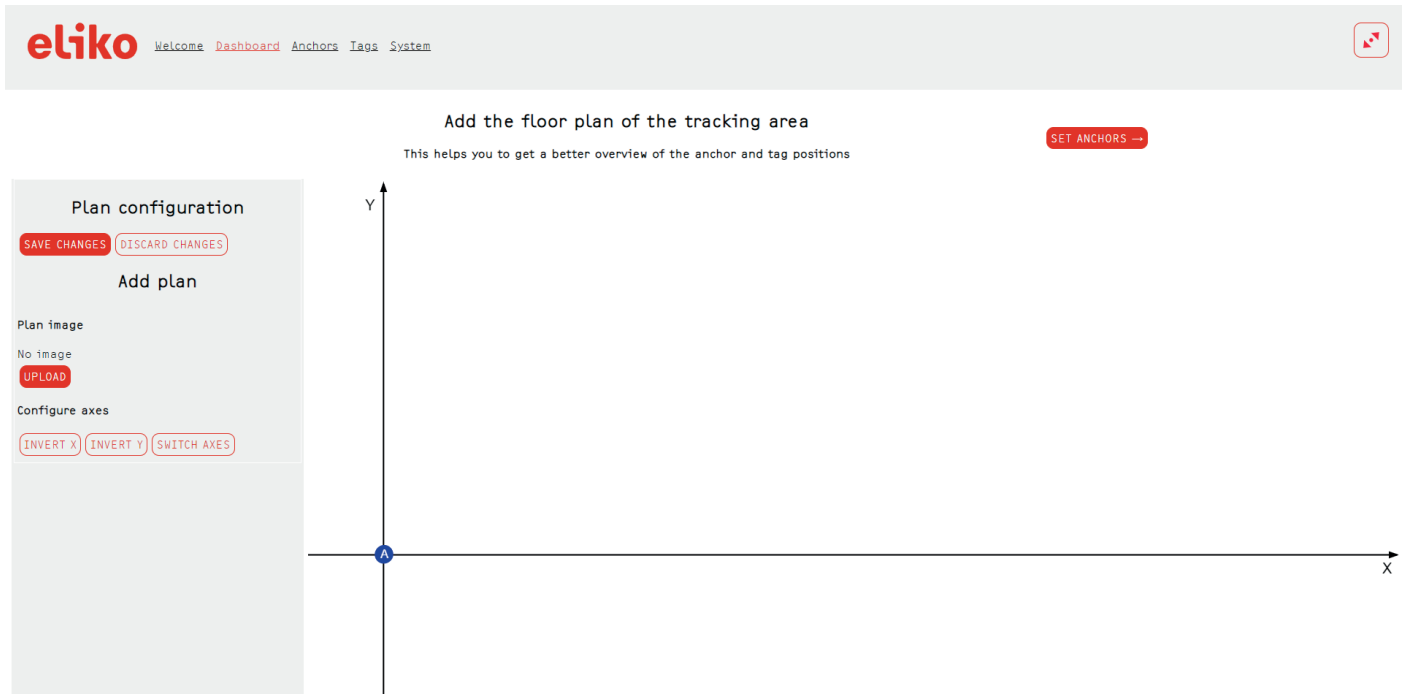

Figure 8. Plan configuration page.

Add a floorplan (optional) of your tracking area by clicking "Upload". Next, go to "Configure the axes" to match the X- and Y-axes on the plan with the actual zero coordinate and axes. The positive direction of an axis can be changed by clicking on the "Invert X (Y)" button. Also, you can switch axes by clicking the "Switch axes" button. Click and hold down left mouse button to drag floorplan to the position that you want. Click and hold the resizing icon on the top right corner of the floorplan to resize the plan. Another option is to adjust the plan coordinates. Plan coordinates enable you to resize the image and move it around to match the anchor placement. Click "Save changes" button to save the changes.

Next, go to the list of anchors by clicking the "Anchors" menu button.

b. Anchors list

Under the "Anchors" tab you should see all of the anchors with their S/N that are connected to the server. The green or red dot in front of each anchor indicates if it is on- or offline.

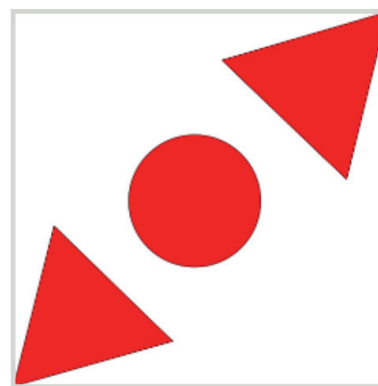

Figure 9. floorplan resizing icon

You can also adjust anchor coordinates under the "Anchors" tab. To save the coordinates click the "Save new anchor coordinates" button.



Under the "Anchors" tab you may also see the "Change anchor's role" pop-up menu. You can't configure roles anymore because after recent improvements to our system,

we do not use roles and we have not yet removed these rudiments from the Eliko RTLS Manager. All the anchors are visible as having role "A" at the moment.

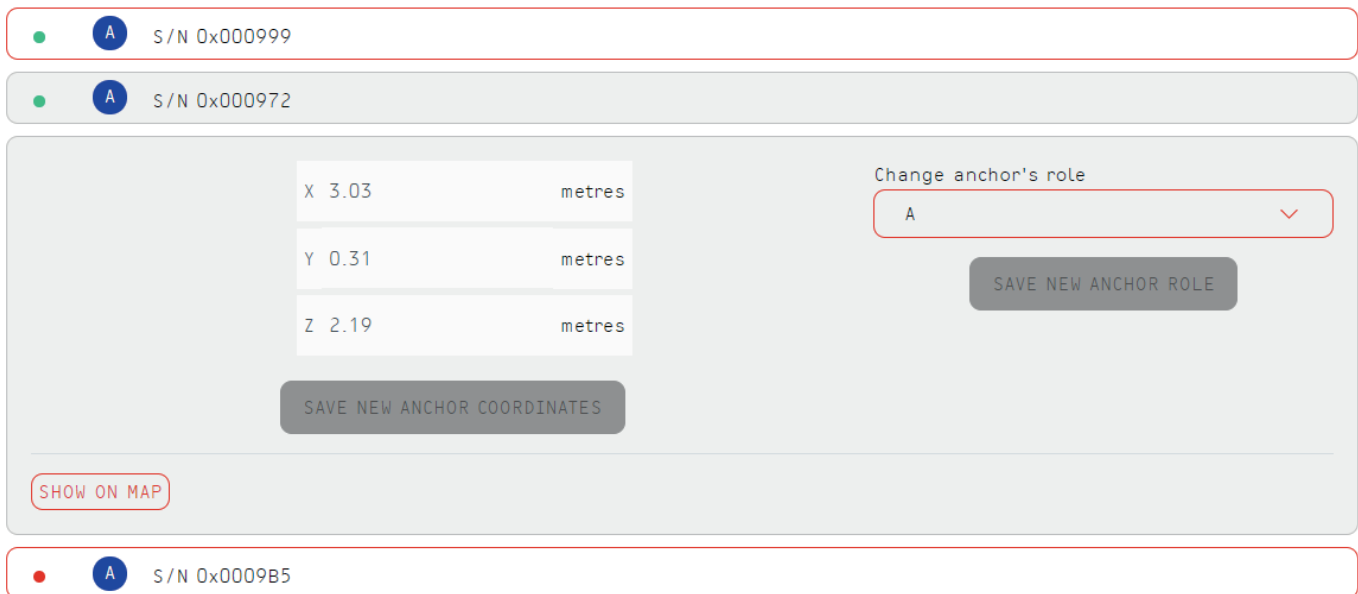

Figure 10. View of the anchors list.

c. Tags List

The "Tags" tab gives you an overview of all the tags that have been connected to the server. Tags have a green/red/yellow colour indication for being on- or offline or in standstill mode. Since the tags operate on batteries, it is important to keep an eye on the battery level to avoid data loss during tracking.

For 2D positioning, you must define the fixed height of the tag, which should be as close to the real height of the tag as possible.

Each tag has a configurable update rate. The highest update rate available in the Eliko RTLS Manager is 10 times per second (10 Hz), while the lowest is once per minute. It is possible to select update rates as high as 150 times per second (150 Hz) by using the Eliko RTLS Communication

Protocol. Contact ELIKO to receive the PDF version of this document or find it under the "System/Documentation" tab.

You can also use the option for dynamic update interval, which is useful when the tracked object is occasionally stationary. The location data is received with high update interval while the tag is moving, and when it stays stationary it will reduce the update rate to the level of low update interval. High update interval can only be smaller or equal to low update interval.

Offline tags show the date and time of when the last coordinate was calculated. Also, the system saves and displays the tag's last position before going offline on the dashboard, which can be useful for locating the tag.



Figure 11. View of the tags list.

d. Dashboard

The dashboard is a visualisation tool where you can see all of the tags moving in real time. Here you can also see if the anchors are placed correctly relative to the floorplan. Different options allow you to display all devices or, for example, only online devices. Default screen refresh rate is 10 Hz.

You can use the dashboard to verify the positioning accuracy of the Eliko RTLS system. For example, walk through the tracking area to make sure the physical location of the tag matches the displayed location on the floorplan. Information about every device is shown while clicking on the icons on the map. The system displays the device's serial number, alias (for tags), battery level (for tags) and current coordinate.

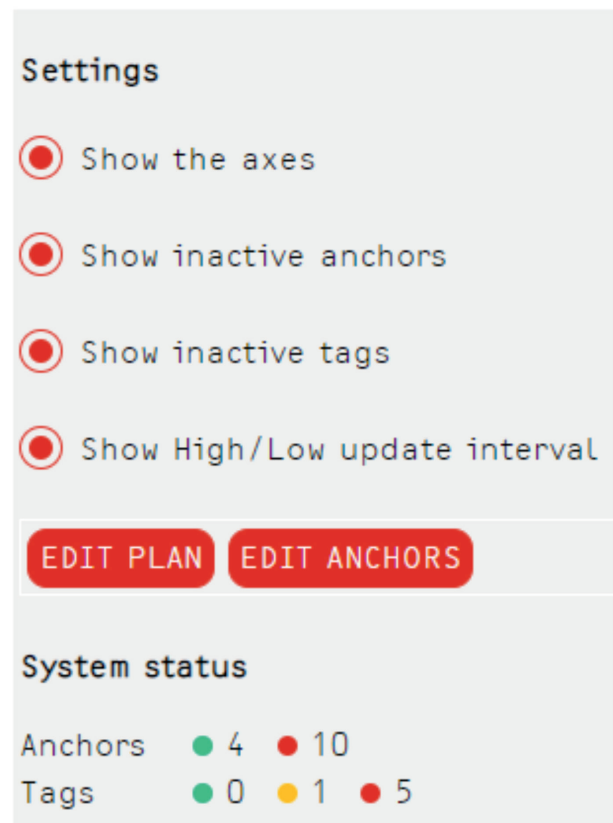

Figure 12. Visualisation options for the dashboard.



8. CLIENT SOFTWARE INTEGRATION

The Eliko RTLS Server communicates with external parties via TCP ports. It can act both as a TCP server or a client. The Eliko RTLS Server is always listening for incoming TCP connection requests on port 25025. You can use the Eliko RTLS Server's IP address and port 25025 to create a connection to the Eliko RTLS Server from your own application. You can then configure the Eliko RTLS from your own application, as well as to get live positioning data. Alternatively, the Eliko RTLS Server can instead act as a

TCP client and connect to your server. For that, go to the "System/General Settings" tab on the Eliko RTLS Manager and select the IP address and TCP port your server is listening from.

Additional instructions on how to integrate the Eliko RTLS to your own application can be found under the "System/Documentation" tab in the Eliko RTLS Manager.

9. TURNING OFF THE SYSTEM

Do not unplug the server directly from the mains power because it can possibly corrupt the file system. To power down, use the on/

off button on the server. After the server power indicator light has turned off, it is safe to unplug the devices.

NOTICE:

This device complies with Part 15 of the FCC Rules.

Operation is subject to the following two conditions:

(1) this device may not cause harmful interference, and

(2) this device must accept any interference received, including interference that may cause undesired operation.

NOTICE:

Changes or modifications made to this equipment not expressly approved by Eliko may void the FCC authorization to operate this equipment.

NOTICE:

The range of the devices may be negatively affected by devices operating at the same wavelength.

NOTICE:

According to FCC rules, the anchors may only be operated indoors. Operation outdoors is in violation of 47 U.S.C. 301 and could subject the operator to serious legal penalties.



NOTICE:

This equipment has been tested and found to comply with the limits for a Class B digital device, pursuant to part 15 of the FCC Rules. These limits are designed to provide reasonable protection against harmful interference in a residential installation. This equipment generates, uses and can radiate radio frequency energy and, if not installed and used in accordance with the instructions, may cause harmful interference to radio communications. However, there is no guarantee that interference will not occur in a particular installation. If this equipment does cause harmful interference to radio or television reception, which can be determined by turning the equipment off and on, the user is encouraged to try to correct the interference by one or more of the following measures:

- Reorient or relocate the receiving antenna.
- Increase the separation between the equipment and receiver.
- Connect the equipment into an outlet on a circuit different from that to which the receiver is connected.
- Consult the dealer or an experienced radio/TV technician for help.

Date	Version (Version.Revision)	Edited By	Description of Change
12.10.2020	20201012_1	T. Pikkmaa	Initial document
07.07.2021	20210707_2	T. Pikkmaa	Revision