

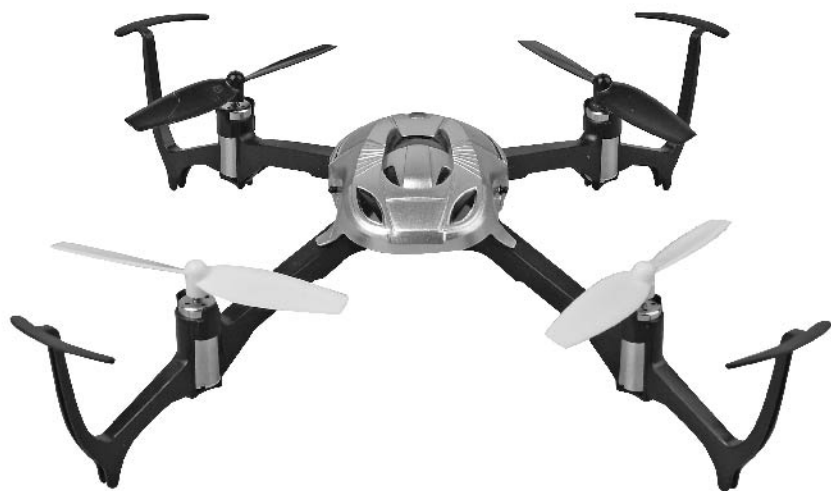

4 - CHANNEL QUADCOPTER

EACHINE 3D X4 INSTRUCTION MANUAL



Orientation mode

1. Main Features

1. 4 motors driven, leading to steady flight and rolling
2. Easily install and fix
3. Adopt 6-gyro, one key 3D flip. Easy control, better flight

2. Parts of the Quadcopter

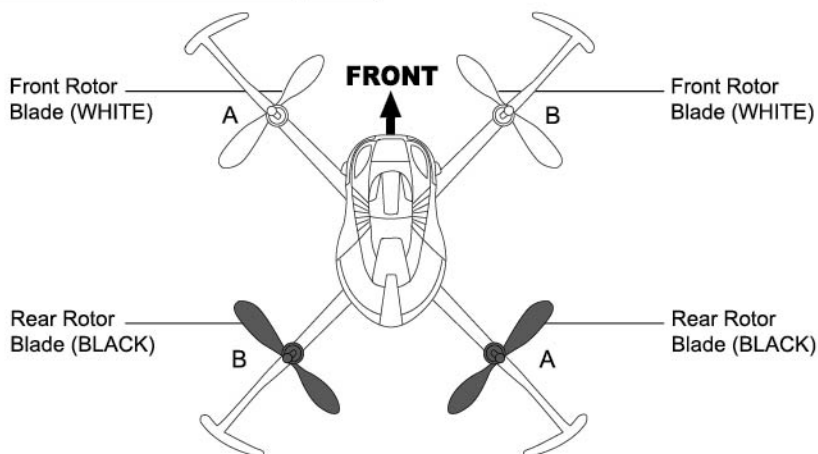

3. Parts of the Transmitter

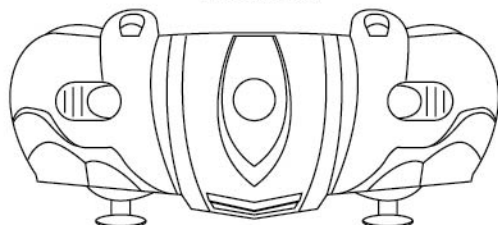
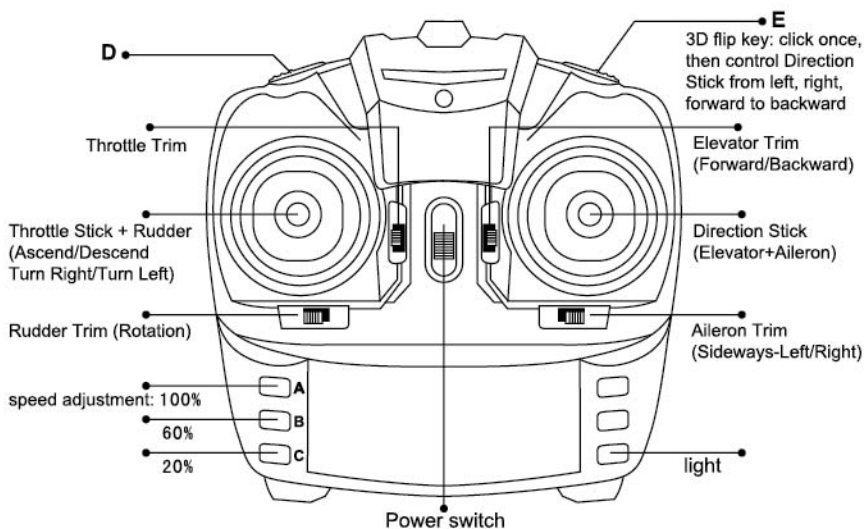

Model:CG031

FCC ID:2AE8UCG031

4. Safety Precautions

1. Please read these Instructions carefully and follow them when operating the Quadcopter.
2. Fly the quadcopter within your line of vision for easier control.
3. Never fly the quadcopter in crowded areas, near to toward people or animals, to prevent property damage and/or personal injury.
4. Do not attempt to modify the product.
5. Keep small elements of the product away from small children, to avoid CHOKING accidents.
6. Keep at least 1-2 meters distance from the quadcopter when it is flying, to avoid injury.
7. Do not dispose the batteries in the heat (fire, electronic heating device, etc.).
8. Do not dispose the quadcopter in wet (rain, moisture, dust, fog etc.) to avoid the parts malfunction.
9. Parental guidance is highly recommended.

5. Preparation to Fly

1. This quadcopter is designed for Outdoor, Indoor flight. However it is important to note the recommended conditions and flying environment.
Choose a place with a minimum of potentially hazardous obstacles.
Recommended minimum flying area: 8m x 8m x 4m
2. Make sure the batteries of the quadcopter and transmitter are fully charged.
3. Turn the transmitter "OFF". Push the Throttle Stick downwards to the minimum position. Place the transmitter close to the quadcopter.
4. Connect the charged Li-PO battery to the PCB. LEDs start to flicker. Do Not Move the quadcopter after this point. Switch "ON" the transmitter. The binding process is on.
5. Check carefully the batteries and motors. Make sure all in condition.
6. Recommended condition to Flip: battery voltage at 3.8V~4V.

6. Installing Transmitter Batteries

1. Slide open the Battery Compartment Lid
2. Insert 4 AA batteries, in the Polarity direction indicated. Do not mix battery types. (Batteries not included)
3. Close Battery Compartment Lid.

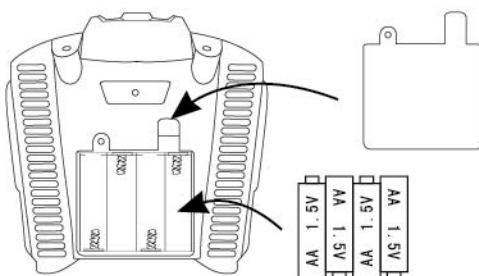

7. Charging the Quadcopter Li-PO Battery

1. Connect Li-PO Battery to the USB charger.
2. RED LED on USB indicates charging is complete. RED LED off indicates charging is in progress.

REMARK: the USB in pack only can use in this quadcopter.

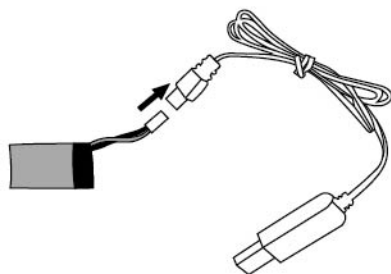

8. Binding the Quad Receiver with the Remote

1. Turn the Transmitter "OFF". Push the Throttle Stick downward to the minimum position. Place the Transmitter close to the Quadcopter.
2. Turn the Quadcopter upside down. The Main PCB is now visible, facing upwards.
3. Push the Battery into the enclosure under the PCB. Connect the charged Li-PO battery to the PCB.
4. Place the Quadcopter on a FLAT surface. WHITE LED starts to flicker. Do Not Move the Quadcopter after this point!
5. Switch "ON" the transmitter. The RED LED in the centre of the Transmitter blinks rapidly, indicating the binding process is on.
6. When the RED LED on the PCB and the LED in the transmitter remain constant, the binding process is complete. Push the Throttle Stick to the maximum position then to minimum position.
7. When the Li-Po battery lacking power, the WHITE LED will flicker until landing.

IMPORTANT: Do Not Move the Quadcopter while the Binding process is on, as the Gyro is being Set to Neutral!



battery pack

battery installation instruction



connect the battery with PCB, binding.

9. Important Information

1. If the quadcopter moves sideways, using the transmitter to trim adjustment. Push the Throttle Stick to lower right corner until the WHITE LED of the quadcopter flickers. It is same with the Aileron Trim on the transmitter. Recommended voltage while trimming is above 4.0V.
2. Orientation Mode Operation
Press the Orientation Mode key for once, after sounding Dee Dee Dee, and then it set.
3. Switch OFF the transmitter or no control for 50 seconds, the Quadcopter will be Auto Sleep.

10. Setting Quadcopter Response

The 3 Response buttons on the Remote are used to change the percentage of response of the Quadcopter.

C: 20% = Least Response (For Beginners)

B: 60% = Press to raise the level to 60% (For Skillful)

A: 100% = Press to 100%. Highest Response (For Expert Fliers)

11. 3D Flight Techniques

Rolls and flips are advanced flying techniques and should be attempted once you have mastered the art of controlling the quadcopter in flight. The speed should be in 100%.

1. Select an open space OUTDOORS, clear of obstacles and away from bystanders.
2. With the Quadcopter hovering steadily (3m above the ground), click the "Orientation Mode" (D) button on the left side of the Transmitter with your index finger. Then click the "ROLL" button (E) on the Right side of the Transmitter with your index finger. Push the Stick to Forward, Backward, Left or Right, the quadcopter will 3D Flip. (For Skillful Fliers)

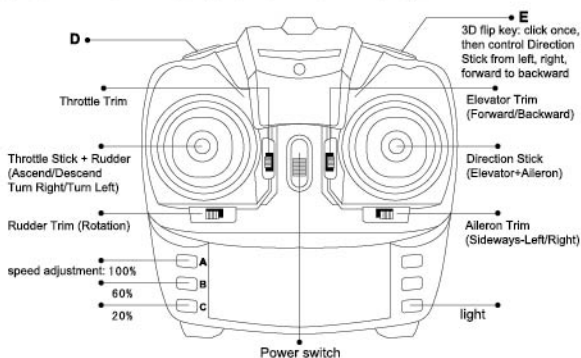

12. Receiver Board Instruction

The Receiver installation should as below pic, otherwise can not work normally.

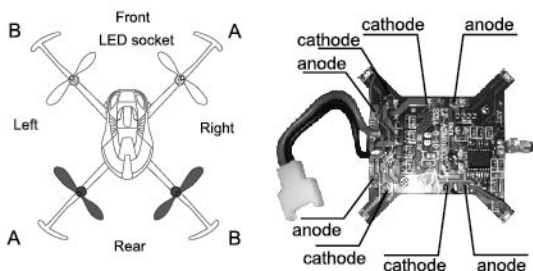

FLIGHT CONTROL

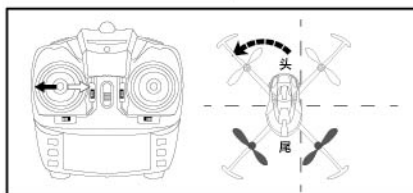

1. When the joystick to the left movement around, Aircraft flying to the left.

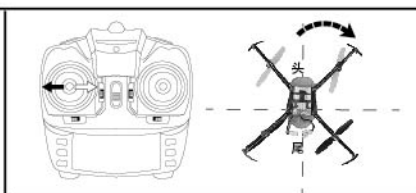

2. When the joystick to the left movement around, Aircraft synchronous inverted to the right.



3. When the joystick around right action, Aircraft flying to the right.

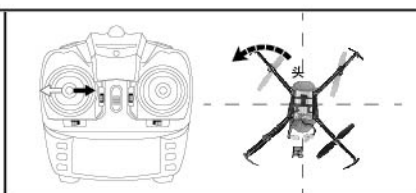

4. When the joystick around right action, Aircraft synchronous inverted to the left.

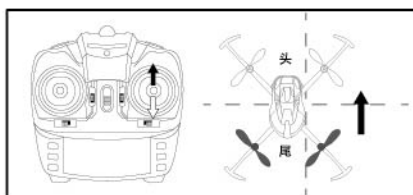

5. When the throttle lever upward movement, Aircraft flying forward.

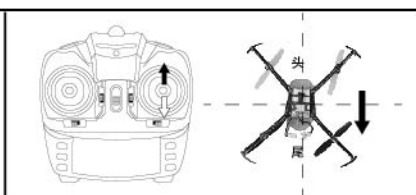

6. When the throttle lever upward movement, After the aircraft flying inverted.

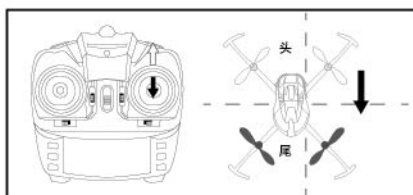

7. When the throttle lever moves down, Aircraft flying back.

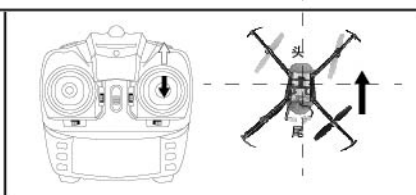

8. When the throttle lever moves down, Aircraft flying forward inverted.

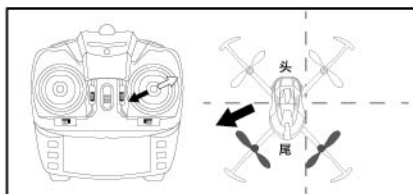

9. When the left joystick (throttle) left, aircraft The fuselage tilted to the left, the aircraft to fly to the left.

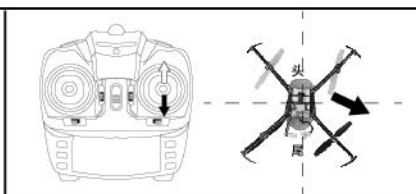

10. When the left joystick (throttle) left, aircraft The fuselage tilted to the left, flying of the aircraft to the right.

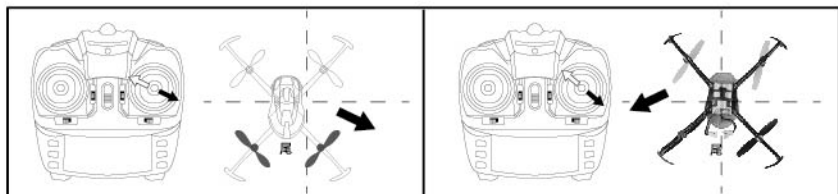

11. When the left joystick (gas) to the right push, aircraft Fuselage tilted to the right, to the right side of the aircraft is flying.

12. When the left joystick (gas) to the right push, aircraft The fuselage tilted to the left, the aircraft to fly to the left.

13. Spare Parts (selective purchasing)

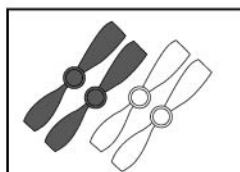

CG031-01
blades

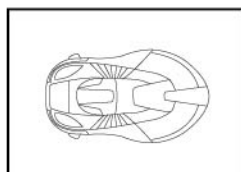

CG031-02
canopy

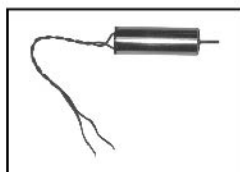

CG031-03
Forward motor
components

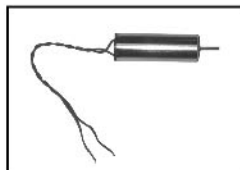

CG031-04
Inversion motor
components

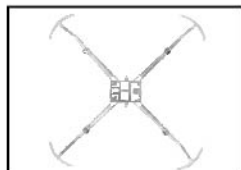

CG031-05
main frame



CG031-06
receiver



CG031-07
USB



CG031-08
battery

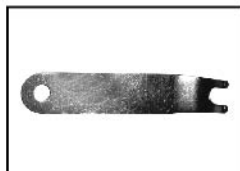

CG031-09
blade plier

NOTE: This equipment has been tested and found to comply with the limits for a Class B digital device, pursuant to part 15 of the FCC Rules. These limits are designed to provide reasonable protection against harmful interference in a residential installation. This equipment generates, uses and can radiate radio frequency energy and, if not installed and used in accordance with the instructions, may cause harmful interference to radio communications. However, there is no guarantee that interference will not occur in a particular installation. If this equipment does cause harmful interference to radio or television reception, which can be determined by turning the equipment off and on, the user is encouraged to try to correct the interference by one or more of the following measures:

- Reorient or relocate the receiving antenna.
- Increase the separation between the equipment and receiver.
- Connect the equipment into an outlet on a circuit different from that to which the receiver is connected.
- Consult the dealer or an experienced radio/TV technician for help.

This device complies with part 15 of the FCC rules. Operation is subject to the following two conditions:

- (1) this device may not cause harmful interference, and
- (2) this device must accept any interference received, including interference that may cause undesired operation.

Changes or modifications to this unit not expressly approved by the party responsible for compliance could void the user's authority to operate the equipment.

The device meets RF Exposure without any restriction.