

TEST REPORT

FCC ID: 2ADYY-KM9

Product: Mobile Phone

Model No.: KM9

Trade Mark: TECNO

Report No.: WSCT-ANAB-R&E250800067A-RF

Issued Date: 02 September 2025

Issued for:

TECNO MOBILE LIMITED
FLAT N 16/F BLOCK B UNIVERSAL INDUSTRIAL CENTRE 19-25 SHAN MEI
STREET FOTAN NT HONGKONG

Issued By:

World Standardization Certification & Testing Group (Shenzhen) Co., Ltd.
Building A-B, Baoli'an Industrial Park, No.58 and 60, Tangtou Avenue, Shiyan
Street, Bao'an District, Shenzhen City, Guangdong Province, China

TEL: +86-755-26996192

FAX: +86-755-86376605



Note: *This report shall not be reproduced except in full, without the written approval of World Standardization Certification & Testing Group (Shenzhen) Co., Ltd. This document may be altered or revised by World Standardization Certification & Testing Group (Shenzhen) Co., Ltd. personnel only, and shall be noted in the revision section of the document. The test results in the report only apply to the tested sample.*



TABLE OF CONTENTS

1. GENERAL INFORMATION	3
2. GENERAL DESCRIPTION OF EUT	4
3. FACILITIES AND ACCREDITATIONS	9
3.1. FACILITIES	9
3.2. ACCREDITATIONS	9
3.3. EUT SYSTEM CONFIGURATION	10
3.4. DESCRIPTION OF TEST CHANNELS AND TEST MODES	11
3.5. EQUIPMENT MODIFICATIONS	19
4. SUMMARY OF TEST REQUIREMENTS AND RESULTS	20
5. MEASUREMENT INSTRUMENTS	21
6. Transmitter Radiated Power (EIRP/ERP)	22
7. Peak to Average Ratio	24
7.2. TEST RESULT	26
8. SPURIOUS EMISSION (Conducted and Radiated)	27
8.1. MEASUREMENT RESULT (PRE-MEASUREMENT)	27
9. OCCUPIED BANDWIDTH& EMISSION BANDWIDTH	104
9.1. MEASUREMENT RESULT	106
10. BAND EDGE	107
10.1. MEASUREMENT RESULT	108
11. SPURIOUS EMISSION (Conducted and Radiated)	109
11.1. MEASUREMENT RESULT (PRE-MEASUREMENT)	109
12. FREQUENCY STABILITY	111
12.1. MEASUREMENT RESULT (WORST)	112
13. Test Setup Photographs	113

1. GENERAL INFORMATION

Product:	Mobile Phone
Model No.:	KM9
Trade Mark:	TECNO
Applicant:	TECNO MOBILE LIMITED FLAT N 16/F BLOCK B UNIVERSAL INDUSTRIAL CENTRE 19-25 SHAN MEI STREET FOTAN NT HONGKONG
Manufacturer:	TECNO MOBILE LIMITED FLAT N 16/F BLOCK B UNIVERSAL INDUSTRIAL CENTRE 19-25 SHAN MEI STREET FOTAN NT HONGKONG
Date of receipt	23 July 2025
Date of Test:	24 July 2025 to 02 September 2025
Applicable Standards:	FCC CFR Title 47 Part 2, 22, 24 ,27, 90 ANSI C63.26-2015

The above equipment has been tested by World Standardization Certification & Testing Group (Shenzhen) Co., Ltd. And found compliance with the requirements set forth in the technical standards mentioned above. The results of testing in this report apply only to the product, which was tested. Other similar equipment will not necessarily produce the same results due to production tolerance and measurement uncertainties.

Tested By: Wang Xiang
(Wang Xiang)

Checked By: Qin Shuiquan
(Qin Shuiquan)

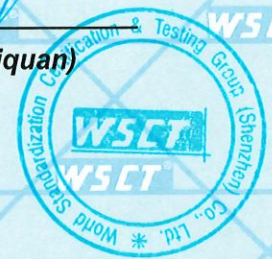

Approved By: Li Huaibi
(Li Huaibi)

Date: 02 September 2025



2. GENERAL DESCRIPTION OF EUT

Equipment Type:	Mobile Phone
Model	KM9
Software Version	KM9-15.1.2
Hardware Version	V1.1
Trade Mark	TECNO
Operating Bands	GSM/GPRS/EGPRS 850/1900 MHz WCDMA/HSDPA/HSUPA Band 2/4/5 FDD LTE Band 2/4/5/7/12/13/17/66 TDD LTE Band 38/41/42 FDD NR Band 5/7/12/66 TDD NR Band 38/41/77/78
Antenna Type:	Integral Antenna
Antenna gain:	GSM 850/WCDMA B5/LTE B5/NR N5: -8.3dbi PCS 1900/WCDMA B2/LTE B2: -3.01dbi WCDMA B4/LTE B4/ LTE B66/NR N66: -3.97dbi LTE B7/ LTE B38/ LTE B41/ NR N7/ NR N38/ NR N41:-2.24dbi LTE B12/LTE B17/NR N12:-7.9dbi LTE B13: -8.1dBi LTE B42/NR 77/NR 78: -1.89dBi
Radiated Power (EIRP/ERP) Limit	GSM 850/WCDMA B5/LTE B5/NR N5: 7.00W(38.45dBm) PCS 1900/WCDMA B2/LTE B2: 2.00W(33.01dBm) WCDMA B4/LTE B4/ LTE B66/NR N66: 1.00W(30.00dBm) LTE B7/LTE B38/LTE B41/NR N7/NR N38/NR N41: 2.00W(33.01dBm) LTE B12/B13/B17 /NR N12: 3.00W(34.77dBm) LTE B42/NR 77/NR 78: 1.00W(30.00dBm)
Operation Frequency Range:	GSM850: 824-849MHz (TX), 869-894MHz (RX) PCS1900: 1850-1910MHz (TX), 1930-1990MHz (RX) WCDMA Band2: 1850-1910MHz (TX), 1930-1990MHz (RX); WCDMA Band4: 1710-1755MHz (TX), 2110-2155MHz (RX); WCDMA Band5: 824-849MHz (TX), 869-894MHz (RX); LTE Band2: 1850-1910MHz (TX), 1930-1990MHz (RX); LTE Band4: 1710-1755MHz (TX), 2110-2155MHz (RX); LTE Band5: 824-849MHz (TX), 869-894MHz (RX); LTE Band7: 2500-2570MHz (TX), 2620-2690MHz (RX); LTE Band12: 699-716MHz (TX), 729-746MHz (RX); LTE Band13: 777-787MHz (TX), 746-756MHz (RX); LTE Band17: 704-716MHz (TX), 734-746MHz (RX); LTE Band38: 2570-2620MHz(TX), 2570-2620MHz(RX); LTE Band41: 2496-2690 MHz(TX), 2496-2690 MHz(RX); LTE Band42: 3450-3550 MHz(TX), 3450-3550 MHz(RX); LTE Band66:1710-1780 MHz(TX), 2110-2200 MHz(RX); LTE UL CA:



	<p>CA_B2A-B4A, CA_B2A-B5A, CA_B2A-B7A, CA_B4A-B5A, CA_B4A-B7A, CA_B4A-B17A, CA_B7A-B5A, CA_7C, CA_38C, CA_41C, CA_66C</p> <p>NR Band5: 824-849MHz (TX), 869-894MHz (RX);</p> <p>NR Band7: 2500-2570MHz (TX), 2620-2690MHz (RX);</p> <p>NR Band12: 699-716MHz (TX), 729-746MHz (RX);</p> <p>NR Band38:2570-2620MHz(TX), 2570-2620MHz(RX);</p> <p>NR Band41:2496-2690 MHz(TX), 2496-2690 MHz(RX);</p> <p>NR Band66:1710-1780 MHz(TX), 2110-2200 MHz(RX);</p> <p>NR Band77:3450-3550 MHz(TX), 3450-3550 MHz(RX);</p> <p>NR Band77:3700-3980 MHz(TX), 3700-3980 MHz(RX);</p> <p>NR Band78:3450-3550 MHz(TX), 3450-3550 MHz(RX);</p> <p>NR Band78:3700-3800 MHz(TX), 3700-3800 MHz(RX);</p> <p>NSA(EN-DC):</p> <p>DC_2A_n7A, DC_2A_n66A, DC_2A_n78A,</p> <p>DC_4A_n7A, DC_4A_n38A, DC_4A_n41A, DC_4A_n78A,</p> <p>DC_5A_n7A, DC_5A_n38A, DC_5A_n41A,DC_5A_n66A,</p> <p>DC_5A_n77A,DC_5A_n78A,</p> <p>DC_7A_n7A, DC_7A_n66A, DC_7A_n77A, DC_7A_n78A,</p> <p>DC_38A_n78A</p> <p>DC_41A_n41A, DC_41A_n77A, DC_41A_n78A,</p> <p>DC_66A_n7A, DC_66A_n38A, DC_66A_n41A,DC_66A_n66A,</p> <p>DC_66A_n77A,DC_66A_n78A</p>
<p>Modulation Type</p>	<p>GSM/GPRS: GMSK</p> <p>EGPRS: 8PSK</p> <p>WCDMA: QPSK</p> <p>HSDPA/HSUPA: QPSK /16QAM</p> <p>LTE: QPSK/16QAM</p> <p>NR: BPSK/ QPSK/16QAM/64QAM/256QAM</p>
<p>Operating Voltage:</p>	<p>Adapter: U450TSB</p> <p>Input: 100-240V~50/60Hz 1.8A</p> <p>Output/Salida: 5.0V~3.0A 15.0W</p> <p>or 5.0-10.0V~4.5A</p> <p>or 11.0V~4.1A 45.0W Max</p> <p>Rechargeable Li-ion Polymer Battery: BL-50FT</p> <p>Nominal Voltage: 3.92V</p> <p>Rated Capacity: 5060mAh</p> <p>Nominal Energy: 19.84Wh</p> <p>Typical Capacity: 5160mAh</p> <p>Limited Charge Voltage: 4.53V</p>
<p>Max power:</p>	<p>See Table 2.1</p>
<p>Remark:</p>	<p>N/A.</p>



- Note:
1. The EUT is a Mobile Phone, supporting dual SIM card slots under the same transceiver. Both SIM card slots support GSM, WCDMA, LTE, NR and both SIM card slots share the same transceiver, so only SIM1 is tested in this report.
 2. The antenna gain provided by the applicant, and the laboratory will not be responsible for the accumulated calculation results which covers the information provided by the applicant.
 3. N/A stands for no applicable.
 4. Antenna gain provided by the customer.

Table 2.1 Maximum power in the operating frequency band.

Operation Band (s)	Power Class	Modulation Type	Maximum conducted output power (dBm)	ERP/EIRP (dBm)
GSM 850	Class 4	GMSK	33.03	22.58
EGPRS 850	Class 4	8PSK	32.94	22.94
GSM 1900	Class 1	GMSK	28.04	17.59
EGPRS 1900	Class 1	8PSK	24.34	13.89
WCDMA Band 2	Class 3	QPSK	23.90	20.89
WCDMA Band 4	Class 3	QPSK	23.96	19.99
WCDMA Band 5	Class 3	QPSK	24.22	13.77
E-UTRA Band 2	Class 3	QPSK	23.37	20.36
E-UTRA Band 2	Class 3	16QAM	22.61	19.60
E-UTRA Band 4	Class 3	QPSK	24.12	20.15
E-UTRA Band 4	Class 3	16QAM	23.33	19.36
E-UTRA Band 5	Class 3	QPSK	24.39	13.94
E-UTRA Band 5	Class 3	16QAM	23.71	13.26
E-UTRA Band 7	Class 3	QPSK	23.34	21.10
E-UTRA Band 7	Class 3	16QAM	22.64	20.40
E-UTRA Band 12	Class 3	QPSK	23.58	13.53
E-UTRA Band 12	Class 3	16QAM	24.28	14.23
E-UTRA Band 13	Class 3	QPSK	23.59	13.34
E-UTRA Band 13	Class 3	16QAM	23.04	12.79
E-UTRA Band 17	Class 3	QPSK	24.35	14.10
E-UTRA Band 17	Class 3	16QAM	23.71	13.46
E-UTRA Band 38	Class 3	QPSK	23.62	21.38
E-UTRA Band 38	Class 3	16QAM	23.06	20.82
E-UTRA Band 41	Class 3	QPSK	23.61	21.37
E-UTRA Band 41	Class 3	16QAM	23.00	20.76

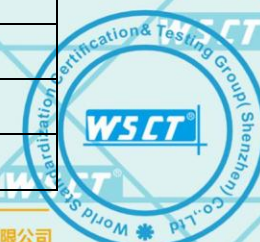

E-UTRA Band 42 (3450-3550Mhz)	Class 3	QPSK	21.46	23.35
	Class 3	16QAM	21.06	22.95
E-UTRA Band 66	Class 3	QPSK	24.34	28.31
E-UTRA Band 66	Class 3	16QAM	23.52	27.49
NR n5	Class 3	BPSK	25.47	15.02
	Class 3	QPSK	25.60	15.15
	Class 3	16QAM	24.80	14.35
	Class 3	64QAM	23.12	12.67
	Class 3	256QAM	20.98	10.53
NR n7	Class 3	BPSK	24.40	22.16
	Class 3	QPSK	24.62	22.38
	Class 3	16QAM	23.72	21.48
	Class 3	64QAM	22.14	19.90
	Class 3	256QAM	20.34	18.10
NR n12	Class 3	BPSK	25.66	15.61
	Class 3	QPSK	25.58	15.53
	Class 3	16QAM	25.03	14.98
	Class 3	64QAM	23.59	13.54
	Class 3	256QAM	21.63	11.58
NR n38	Class 3	BPSK	24.89	22.65
	Class 3	QPSK	25.31	23.07
	Class 3	16QAM	24.08	21.84
	Class 3	64QAM	23.31	21.07
	Class 3	256QAM	20.40	18.16
NR n41	Class 3	BPSK	24.81	22.57
	Class 3	QPSK	26.39	24.15
	Class 3	16QAM	24.07	21.83
	Class 3	64QAM	22.64	20.40
	Class 3	256QAM	20.39	18.15
NR n66	Class 3	BPSK	24.44	20.47
	Class 3	QPSK	24.75	20.78
	Class 3	16QAM	23.67	19.70
	Class 3	64QAM	22.34	18.37

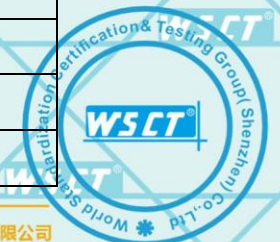

NR n77 (3450-3550Mhz)	Class 3	256QAM	20.09	16.12
	Class 3	BPSK	25.46	23.57
	Class 3	QPSK	25.59	23.70
	Class 3	16QAM	24.49	22.60
	Class 3	64QAM	22.83	20.94
	Class 3	256QAM	21.01	19.12
NR n77 (3700-3980 Mhz)	Class 3	BPSK	24.77	22.88
	Class 3	QPSK	25.01	23.12
	Class 3	16QAM	23.81	21.92
	Class 3	64QAM	22.77	20.88
	Class 3	256QAM	20.30	18.41
	NR n78 (3450-3550 Mhz)	Class 3	BPSK	25.41
Class 3		QPSK	25.64	23.75
Class 3		16QAM	24.59	22.70
Class 3		64QAM	23.09	21.20
Class 3		256QAM	21.12	19.23
NR n78 (3700-3800 Mhz)		Class 3	BPSK	25.07
	Class 3	QPSK	25.59	23.70
	Class 3	16QAM	24.04	22.15
	Class 3	64QAM	22.70	20.81
	Class 3	256QAM	20.47	18.58

3. FACILITIES AND ACCREDITATIONS

3.1. Facilities

All measurement facilities used to collect the measurement data are located at **World Standardization Certification & Testing Group (Shenzhen) Co., Ltd. Building A-B, Baoli'an Industrial Park, No.58 and 60, Tangtou Avenue, Shiyan Street, Bao'an District, Shenzhen City, Guangdong Province, China**

The sites are constructed in conformance with the requirements of ANSI C63.4 and CISPR Publication 32. All receiving equipment conforms to CISPR Publication 16-1, "Radio Interference Measuring Apparatus and Measurement Methods."

3.2. ACCREDITATIONS

Our laboratories are accredited and approved by the following approval agencies according to ISO/IEC 17025:2017.

USA	ANAB - Certificate Number: AT-3951
China	CNAS (Registration Number: L3732)
Canada	ISED(CAB identifier:CN0178)

Copies of granted accreditation certificates are available for downloading from our web site, <http://www.wsct-cert.com>



3.3. EUT System Configuration

The EUT configuration for testing is installed on RF field strength measurement to meet the Commission’s requirement and operating in a manner which intends to maximize its emission characteristics in a continuous normal application.

Fig. 3.2-1 Configuration of EUT System



(EUT: Mobile Phone)

Table 3.2-1 Equipment Used in EUT System

Item	Equipment	Model No.	ID or Specification	Note
1	Adapter	U450TSB		Accessories

***Note: All the accessories have been used during the test. The following “EUT” in setup diagram means EUT system.



3.4. Description Of Test Channels And Test Modes

Test channels:

Test Mode	UL Channel	UL Channel No.	UL Frequency (MHz)
GSM/GPRS/EGPRS 850	Low Channel	128	824.2
	Middle Channel	190	836.6
	High Channel	251	848.8
GSM/GPRS/EGPRS 1900	Low Channel	512	1850.2
	Middle Channel	661	1880.0
	High Channel	810	1909.8
WCDMA Band 2	Low Channel	9262	1852.4
	Middle Channel	9400	1880.0
	High Channel	9538	1907.6
WCDMA Band 4	Low Channel	1312	1712.4
	Middle Channel	1412	1732.6
	High Channel	1513	1752.6
WCDMA Band 5	Low Channel	4132	826.4
	Middle Channel	4182	836.4
	High Channel	4233	846.6

LTE Band2			
Test Channel	BW(MHz)	UL Channel	Frequency(MHz)
Low Range	1.4	18607	1850.7
	3	18615	1851.5
	5	18625	1852.5
	10	18650	1855
	15	18675	1857.5
	20	18700	1860
Mid Range	1.4/3/5/10/15/20	18900	1880
High Range	1.4	19193	1909.3
	3	19185	1908.5
	5	19175	1907.5
	10	19150	1905
	15	19125	1902.5
	20	19100	1900



LTE Band4			
Test Channel	BW(MHz)	UL Channel	Frequency(MHz)
Low Range	1.4	19957	1710.7
	3	19965	1711.5
	5	19975	1712.5
	10	20000	1715
	15	20025	1717.5
	20	20050	1720
Mid Range	1.4/3/5/10/15/20	20175	1732.5
High Range	1.4	20393	1754.3
	3	20385	1753.5
	5	20375	1752.5
	10	20350	1750
	15	20325	1747.5
	20	20300	1745

LTE Band 5			
Test Channel	BW(MHz)	UL Channel	Frequency(MHz)
Low Range	1.4	20407	824.7
	3	20415	825.5
	5	20425	826.5
	10	20450	829
Mid Range	1.4/3/5/10	20525	836.5
High Range	1.4	20643	848.3
	3	20635	847.5
	5	20625	846.5
	10	20600	844



LTE Band 7			
Test Channel	BW(MHz)	UL Channel	Frequency(MHz)
Low Range	5	20775	2502.5
	10	20800	2505
	15	20825	2507.5
	20	20850	2510
Mid Range	5/10/15/20	21100	2535
High Range	5	21425	2567.5
	10	21400	2565
	15	21375	2562.5
	20	21350	2560

LTE Band 12			
Test Channel	BW(MHz)	UL Channel	Frequency(MHz)
Low Range	1.4	23017	699.7
	3	23025	700.5
	5	23035	701.5
	10	23060	704
Mid Range	1.4/3/5/10	23095	707.5
High Range	1.4	23173	715.3
	3	23165	714.5
	5	23155	713.5
	10	23130	711

LTE Band 13			
Test Channel	BW(MHz)	UL Channel	Frequency(MHz)
Range	5	23205	779.5
Mid Range	5/10	23230	782
High Range	5	23255	784.5

LTE Band 17			
Test Channel	BW(MHz)	UL Channel	Frequency(MHz)
Low Range	5	23755	706.5
	10	23780	709
Mid Range	5/10	23790	710
High Range	5	23825	713.5
	10	23800	711



LTE Band 38			
Test Channel	BW(MHz)	UL Channel	Frequency(MHz)
Low Range	5	37775	2572.5
	10	37800	2575
	15	37825	2577.5
	20	37850	2580
Mid Range	5/10/15/20	38000	2595
High Range	5	38225	2617.5
	10	38200	2615
	15	38175	2612.5
	20	38150	2610

LTE Band 41			
Test Channel	BW(MHz)	UL Channel	Frequency(MHz)
Low Range	5	39675	2498.5
	10	39700	2501
	15	39725	2503.5
	20	39750	2506
Mid Range	5/10/15/20	40620	2593
High Range	5	41565	2687.5
	10	41540	2685
	15	41515	2682.5
	20	41490	2680

LTE Band 42(3450-3550Mhz)			
Test Channel	BW(MHz)	UL Channel	Frequency(MHz)
Low Range	5	42115	3452.5
	10	42140	3455
	15	42165	3457.5
	20	42190	3460
Mid Range	5/10/15/20	42590	3500
High Range	5	43065	3547.5
	10	43040	3545
	15	43015	3542.5
	20	42990	3540



LTE Band66			
Test Channel	BW(MHz)	UL Channel	Frequency(MHz)
Low Range	1.4	131979	1710.7
	3	131987	1711.5
	5	131997	1712.5
	10	132022	1715
	15	132047	1717.5
	20	132322	1720
Mid Range	1.4/3/5/10/15/20	132322	1745
High Range	1.4	132665	1779.3
	3	132657	1778.5
	5	132647	1777.5
	10	132622	1775
	15	132597	1772.5
	20	132572	1770



NR n5			
Test Channel	BW(MHz)	UL Channel	Frequency(MHz)
Low Range	10	165800	829
	15	166300	831.5
	20	166800	834
Mid Range	10/15/20	167300	836.5
High Range	10	168800	844
	15	168300	841.5
	20	167800	839

NR n7			
Test Channel	BW(MHz)	UL Channel	Frequency(MHz)
Low Range	10	501000	2505
	15	501500	2507.5
	20	502000	2510
Mid Range	10/15/20	507000	2535
High Range	10	513000	2565
	15	512500	2562.5
	20	512000	2560

NR n12			
Test Channel	BW(MHz)	UL Channel	Frequency(MHz)
Low Range	10	140800	704
	15	141300	706.5
Mid Range	10/15	141500	707.5
High Range	10	142200	711
	15	141700	708.5

NR n38			
Test Channel	BW(MHz)	UL Channel	Frequency(MHz)
Low Range	10	515000	2575
	15	515500	2577.5
	20	522500	2580
Mid Range	10/15/20	519000	2595
High Range	10	523000	2615
	15	522500	2612.5
	20	522000	2610



NR n41			
Test Channel	BW(MHz)	UL Channel	Frequency(MHz)
Low Range	20	501204	2506
	50	504204	2521
	100	509202	2546
Mid Range	20/50/100	518598	2593
High Range	20	535998	2680
	50	532998	2665
	100	528000	2640

NR n66			
Test Channel	BW(MHz)	UL Channel	Frequency(MHz)
Low Range	10	343000	1715
	20	344000	1720
	40	346000	1730
Mid Range	10/20/40	349000	1745
High Range	10	355000	1775
	20	354000	1770
	40	349000	1760

NR n77(3450-3550Mhz)			
Test Channel	BW(MHz)	UL Channel	Frequency(MHz)
Low Range	10	630334	3455
	50	631668	3475
Mid Range	10/50/100	633334	3500
High Range	10	636332	3545
	50	635000	3525



NR n77(3700-3980Mhz)			
Test Channel	BW(MHz)	UL Channel	Frequency(MHz)
Low Range	10	647000	3705
	50	648334	3725
	100	650000	3750
Mid Range	10/50/100	656000	3890
High Range	10	665000	3975
	50	663666	3955
	100	662000	3930

NR n78(3450-3550Mhz)			
Test Channel	BW(MHz)	UL Channel	Frequency(MHz)
Low Range	10	630334	3455
	50	631668	3475
Mid Range	10/50/100	633334	3500
High Range	10	636332	3545
	50	635000	3525

NR n78(3700-3800Mhz)			
Test Channel	BW(MHz)	UL Channel	Frequency(MHz)
Low Range	10	647000	3705
	50	648334	3725
Mid Range	10/50/100	650000	3750
High Range	10	653000	3795
	50	651666	3775

Note 1: BPSK&QPSK&16QAM&QAM64&QAM256 modulation has been measured;
 Note 2: The worst condition was recorded in the test report if no other modes test data.



3.5. Equipment Modifications

Not available for this EUT intended for grant.



4. SUMMARY OF TEST REQUIREMENTS AND RESULTS

No.	Description	FCC Part No.	Test Verdict	Remark
1	Conducted RF Output Power	2.1046	Pass	--
2	Effective (Isotropic) Radiated Power	2.1046 22.913(a) 24.232(c) 27.50 90.635(b) 90.542(a) §90.1321(a)	Pass	--
3	Peak to Average Ratio	2.1046 22.913(d) 24.232(d) 27.50(d)	Pass	--
4	Occupied Bandwidth	2.1049 22.917(b) 24.238(b) 27.53 90.209	Pass	--
5	Frequency Stability	2.1055 22.355 24.235 27.54 90.213	Pass	--
6	Spurious Emission at Antenna Terminals	2.1051 22.917 24.238 27.53 90.691 90.543	Pass	--
7	Band Edge	2.1051 22.917 24.238 27.53 90.691 90.543	Pass	--
8	Field Strength of Spurious Radiation	2.1053 22.917 24.238 27.53 90.691 90.543	Pass	--



5. MEASUREMENT INSTRUMENTS

NAME OF EQUIPMENT	MANUFACTURER	MODEL	SERIAL NUMBER	Calibration Date	Calibration Due.
EMI Test Receiver	R&S	ESCI	100005	2024-11-05	2025-11-04
LISN	AFJ	LS16	16010222119	2024-11-05	2025-11-04
LISN(EUT)	Mestec	AN3016	04/10040	2024-11-05	2025-11-04
Universal Radio Communication Tester	R&S	CMU 200	1100.0008.02	2024-11-05	2025-11-04
Coaxial cable	Megalon	LMR400	N/A	2024-11-05	2025-11-04
GPIB cable	Megalon	GPIB	N/A	2024-11-05	2025-11-04
Spectrum Analyzer	R&S	FSU	100114	2024-11-05	2025-11-04
Pre Amplifier	H.P.	HP8447E	2945A02715	2024-11-05	2025-11-04
Pre-Amplifier	CDSI	PAP-1G18-38	--	2024-11-05	2025-11-04
Loop Antenna	R&S	HFH2-Z2	100296	2024-11-05	2025-11-04
Bi-log Antenna	SCHWARZBECK	VULB9168	01488	2025-07-29	2026-07-28
9*6*6 Anechoic	--	--	--	2024-11-05	2025-11-04
Horn Antenna	COMPLIANCE ENGINEERING	CE18000	--	2024-11-05	2025-11-04
Horn Antenna	SCHWARZBECK	BBHA9120D	9120D-631	2024-11-05	2025-11-04
Power meter	Anritsu	ML2487A	6K00003613	2024-11-05	2025-11-04
Power meter	Anritsu	MA2491A	32263	2024-11-05	2025-11-04
Cable	TIME MICROWAVE	LMR-400	N-TYPE04	2024-11-05	2025-11-04
System-Controller	CCS	N/A	N/A	N.C.R	N.C.R
Turn Table	CCS	N/A	N/A	N.C.R	N.C.R
Antenna Tower	CCS	N/A	N/A	N.C.R	N.C.R
RF cable	Murata	MXHQ87WA3000	-	2024-11-05	2025-11-04
Loop Antenna	EMCO	6502	00042960	2024-11-05	2025-11-04
Wideband Radio Communication Tester	R&S	CMW 500	103974	2024-11-05	2025-11-04
Horn Antenna	SCHWARZBECK	BBHA 9170	1123	2024-11-05	2025-11-04
H & T Chamber	Guangzhou gongwen	GDJS-500-40	0329	2024-11-05	2025-11-04
UXM 5G Wireless Test Platform	KEYSIGHT	E7515B	MY60192341	2024-11-05	2025-11-04
Anechoic chamber	SAEMC	966	-	2024-11-05	2025-11-04
Spectrum Analyzer	KEYSIGHT	N9010B	MY60241089	2024-11-05	2025-11-04



6. Transmitter Radiated Power (EIRP/ERP)

Test limit:

FCC § 2.1046 & 22.913(a) & 24.232(c) & 27.50(a) & 27.50(b) & 27.50(c) & 27.50(d) & 27.50(h) & 27.50(j) & 27.50(k) & 90.635(b) & 90.542(a)

According to FCC section 22.913(a) (5), the Effective Radiated Power (ERP) of mobile transmitters and auxiliary test transmitters must not exceed 7 watts.

According to FCC section 24.232(c), mobile and portable stations are limited to 2 watts EIRP and the equipment must employ a means for limiting power to the minimum necessary for successful communications.

According to FCC section 27.50(a) (3), for mobile and portable stations transmitting in the 2305-2315MHz band or the 2350-2360MHz band, the average EIRP must not exceed 50 mill watts within any 1 megahertz of authorized bandwidth, except that for mobile and portable stations compliant with 3GPP LTE standards. For mobile and portable stations using time division depleting (TDD) technology, the duty cycle must not exceed 38 percent in the 2305-2315 MHz and 2350-2360 MHz bands.

FCC section 27.50(b) (10), portable stations (hand-held devices) transmitting in the 746-757MHz, 776-788MHz, and 805-806MHz bands are limited to 3 watts ERP.

FCC section 27.50(c) (10), portable stations (hand-held devices) in the 600MHz uplink band and the 698-746MHz band, and fixed and mobile stations in the 600MHz uplink band are limited to 3 watts ERP.

FCC section 27.50(d) (4), fixed, mobile, and portable (hand-held) stations operating in the 1710-1755 MHz band and mobile and portable stations operating in the 1695-1710 MHz and 1755-1780 MHz bands are limited to 1 watt EIRP. Fixed stations operating in the 1710-1755 MHz band are limited to a maximum antenna height of 10 meters above ground. Mobile and portable stations operating in these bands must employ a means for limiting power to the minimum necessary for successful communications.

(7) Fixed, mobile, and portable (hand-held) stations operating in the 2000-2020 MHz band are limited to 2 watts EIRP.

And FCC section 27.50(h) (2), for mobile and other user stations, mobile stations are limited to 2.0 watts EIRP. All user stations are limited to 2.0 watts transmitter output power.

FCC section 27.50(j) (3), for mobile, and portable (hand-held) stations operating in the 3700-3980 MHz band are limited to 1 watt EIRP.

FCC section 27.50(k) (3), Mobile devices are limited to 1Watt (30 dBm) EIRP in the 3450-3550 MHz band.

Test procedure:

Description of the Conducted Output Power Measurement

The EUT is coupled to the SS with attenuator through power splitter; the RF load attached to EUT antenna terminal is 50Ohm; the path loss as the factor is calibrated to correct the reading. A system simulator is used to establish communication with the EUT, and its parameters are set to force the EUT transmitting at maximum output power. The measured power in the radio frequency on the transmitter output terminals shall be reported.

The relevant equation for determining the conducted measured value is:

Conducted Output Power Value (dBm) = Measured Value (dBm) + Path Loss (dB)

where:

Conducted Output Power Value = final conducted measured value in the conducted power test, in dBm;
 Measured Value = measured conducted power received by spectrum analyzer or power meter, in dBm;
 Path Loss = signal attenuation in the connecting cable between the transmitter and spectrum analyzer or power meter, including external cable loss, in dB;

During the test, the data of Path Loss (dB) is added in the spectrum analyzer or power meter, so Measured Value (dBm) is the final values which contains the data of Path Loss (dB).



Description of the Transmitter Radiated Power Measurement

In many cases, the RF output power limits for licensed digital transmission devices is specified in terms of effective radiated power (ERP) or equivalent isotropic radiated power (EIRP). Typically, ERP is specified when the operating frequency is less than or equal to 1 GHz and EIRP is specified when the operating frequency is greater than 1 GHz. Both are determined by adding the transmit antenna gain to the conducted RF output power with the primary difference between the two being that when determining the ERP, the transmit antenna gain is referenced to a dipole antenna (i.e., dBd) whereas when determining the EIRP, the transmit antenna gain is referenced to an isotropic antenna (dBi).

Final measurement calculation as below

The relevant equation for determining the ERP or EIRP from the conducted RF output power measured using the guidance provided above is:

$$\text{ERP/EIRP} = P_{\text{Meas}} + \text{GT} - \text{LC}$$

where:

ERP/EIRP = effective or equivalent radiated power, respectively (expressed in the same units as P_{Meas}, typically dBW or dBm);

P_{Meas} = measured transmitter output power or PSD, in dBm or dBW;

GT = gain of the transmitting antenna, in dBd (ERP) or dBi (EIRP);

dBd (ERP)=dBi (EIRP) -2.15 dB

LC = signal attenuation in the connecting cable between the transmitter and antenna, in dB.

For devices utilizing multiple antennas, KDB 662911 provides guidance for determining the effective array transmit antenna gain term to be used in the above equation.

The relevant equation for determining the ERP/EIRP from the radiated RF output power is:

$$\text{ERP/EIRP (dBm)} = \text{SA Read Value (dBm)} + \text{Correction Factor (dB)}$$

where:

ERP/EIRP = effective or equivalent radiated power, in dBm;

SA Read Value = measured transmitter power received by EMI receiver or spectrum analyzer, in dBm;

Correction Factor = total correction factor including cable loss, in dB;

During the test, the data of Correction Factor (dB) is added in the EMI receiver or spectrum analyzer, so SA Read Value (dBm) is the final values which contains the data of Correction Factor (dB).

Test Result

Note: Please refer to Annex (GSM&WCDMA<E&NR Chapter 1 Transmitter Radiated Power) for more test data

7. Peak to Average Ratio

7.1.1. Limit

FCC § 2.1046 & 24.232(d) & 27.50(d) & 27.50(j) & 27.50(k)

In addition, when the transmitter power is measured in terms of average value, the peak-to-average power ratio (PAPR) of the transmitter shall not exceed 13 dB for more than 0.1% of the time using a signal corresponding to the highest PAPR during periods of continuous transmission.

According to FCC section 24.232(d), power measurements for transmissions by stations authorized under this section may be made either in accordance with a Commission-approved average power technique or in compliance with 24.232 (e) of this section. In both instances, equipment employed must be authorized in accordance with the provisions of § 24.51. In measuring transmissions in this band using an average power technique, the peak-to-average ratio (PAR) of the transmission may not exceed 13 dB.

FCC section 24.232(e), peak transmit power must be measured over any interval of continuous transmission using instrumentation calibrated in terms of an rms equivalent voltage. The measurement results shall be properly adjusted for any instrument limitations, such as detector response times, limited resolution bandwidth capability when compared to the emission bandwidth, sensitivity, etc., so as to obtain a true peak measurement for the emission in question over the full bandwidth of the channel.

According to FCC section 27.50(d) (5) & 27.50(j) & 27.50(k), in measuring transmissions in this band using an average power technique, the peak-to-average ratio (PAR) of the transmission may not exceed 13dB.

7.1.2. Test Procedure

Here the lowest, middle and highest channels are selected to perform testing to verify the peak-to-average ratio.

According to KDB 971168 D01, there is CCDF procedure for PAPR:

a) Refer to instrument's analyzer instruction manual for details on how to use the power statistics/CCDF function;

b) Set resolution/measurement bandwidth \geq signal's occupied bandwidth;

c) Set the number of counts to a value that stabilizes the measured CCDF curve;

d) Set the measurement interval as follows:

1) for continuous transmissions, set to 1 ms,

2) for burst transmissions, employ an external trigger that is synchronized with the EUT burst timing sequence, or use the internal burst trigger with a trigger level that allows the burst to stabilize and set the measurement interval to a time that is less than or equal to the burst duration.

e) Record the maximum PAPR level associated with a probability of 0.1%.

7.2. Test Result

Note: Please refer to Annex (GSM&WCDMA<E&NR Peak-to-Average Ratio) for more test data

8. SPURIOUS EMISSION (Conducted and Radiated)

8.1 Measurement Result (Pre-measurement)

GSM850:

Test Channel	BW(MHz)	UL Channel	Frequency(MHz)	Judgment
Low Range	0.2	128	824.2	Pass
Middle Range	0.2	190	836.6	Pass
High Range	0.2	251	848.8	Pass

PCS 1900 :

Test Channel	BW(MHz)	UL Channel	Frequency(MHz)	Judgment
Low Range	0.2	512	1850.2	Pass
Middle Range	0.2	661	1880.0	Pass
High Range	0.2	810	1909.8	Pass

UTRA BANDS

Band 2:

Test Channel	BW(MHz)	UL Channel	Frequency(MHz)	Judgment
Low Range	5	9262	1852.4	Pass
Middle Range	5	9400	1880.0	Pass
High Range	5	9538	1907.6	Pass

Band 4:

Test Channel	BW(MHz)	UL Channel	Frequency(MHz)	Judgment
Low Range	5	1312	1712.4	Pass
Middle Range	5	1413	1732.6	Pass
High Range	5	1513	1752.6	Pass

Band 5:

Test Channel	BW(MHz)	UL Channel	Frequency(MHz)	Judgment
Low Range	5	4132	826.4	Pass
Middle Range	5	4182	836.4	Pass
High Range	5	4233	846.6	Pass



E-UTRA BANDS
Band 2:

Bandwidth	UL Channel	Frequency	Modulation	RB Size	RB Offset	Judgment
1.4	18607	1850.7	QPSK	6	LOW	Pass
1.4	18607	1850.7	Q16	6	LOW	Pass
1.4	18900	1880	QPSK	6	LOW	Pass
1.4	18900	1880	Q16	6	LOW	Pass
1.4	19193	1909.3	QPSK	6	LOW	Pass
1.4	19193	1909.3	Q16	6	LOW	Pass
3	18615	1851.5	QPSK	15	LOW	Pass
3	18615	1851.5	Q16	15	LOW	Pass
3	18900	1880	QPSK	15	LOW	Pass
3	18900	1880	Q16	15	LOW	Pass
3	19185	1908.5	QPSK	15	LOW	Pass
3	19185	1908.5	Q16	15	LOW	Pass
5	18625	1852.5	QPSK	25	LOW	Pass
5	18625	1852.5	Q16	25	LOW	Pass
5	18900	1880	QPSK	25	LOW	Pass
5	18900	1880	Q16	25	LOW	Pass
5	19175	1907.5	QPSK	25	LOW	Pass
5	19175	1907.5	Q16	25	LOW	Pass
10	18650	1855	QPSK	50	LOW	Pass
10	18650	1855	Q16	50	LOW	Pass
10	18900	1880	QPSK	50	LOW	Pass
10	18900	1880	Q16	50	LOW	Pass
10	19150	1905	QPSK	50	LOW	Pass
10	19150	1905	Q16	50	LOW	Pass
15	18675	1857.5	QPSK	75	LOW	Pass
15	18675	1857.5	Q16	75	LOW	Pass
15	18900	1880	QPSK	75	LOW	Pass
15	18900	1880	Q16	75	LOW	Pass
15	19125	1902.5	QPSK	75	LOW	Pass
15	19125	1902.5	Q16	75	LOW	Pass
20	18700	1860	QPSK	100	LOW	Pass
20	18700	1860	Q16	100	LOW	Pass
20	18900	1880	QPSK	100	LOW	Pass
20	18900	1880	Q16	100	LOW	Pass
20	19100	1900	QPSK	100	LOW	Pass
20	19100	1900	Q16	100	LOW	Pass

Band 4:

Bandwidth	UL Channel	Frequency	Modulation	RB Size	RB Offset	Judgment
1.4	19957	1710.7	QPSK	6	LOW	Pass
1.4	19957	1710.7	Q16	6	LOW	Pass
1.4	20393	1754.3	QPSK	6	LOW	Pass
1.4	20393	1754.3	Q16	6	LOW	Pass
1.4	20175	1732.5	QPSK	6	LOW	Pass
1.4	20175	1732.5	Q16	6	LOW	Pass
3	19965	1711.5	QPSK	15	LOW	Pass
3	19965	1711.5	Q16	15	LOW	Pass
3	20385	1753.5	QPSK	15	LOW	Pass



Bandwidth	UL Channel	Frequency	Modulation	RB Size	RB Offset	Judgment
3	20385	1753.5	Q16	15	LOW	Pass
3	20175	1732.5	QPSK	15	LOW	Pass
3	20175	1732.5	Q16	15	LOW	Pass
5	19975	1712.5	QPSK	25	LOW	Pass
5	19975	1712.5	Q16	25	LOW	Pass
5	20375	1752.5	QPSK	25	LOW	Pass
5	20375	1752.5	Q16	25	LOW	Pass
5	20175	1732.5	QPSK	25	LOW	Pass
5	20175	1732.5	Q16	25	LOW	Pass
10	20000	1715	QPSK	50	LOW	Pass
10	20000	1715	Q16	50	LOW	Pass
10	20350	1750	QPSK	50	LOW	Pass
10	20350	1750	Q16	50	LOW	Pass
10	20175	1732.5	QPSK	50	LOW	Pass
10	20175	1732.5	Q16	50	LOW	Pass
15	20025	1717.5	QPSK	75	LOW	Pass
15	20025	1717.5	Q16	75	LOW	Pass
15	20325	1747.5	QPSK	75	LOW	Pass
15	20325	1747.5	Q16	75	LOW	Pass
15	20175	1732.5	QPSK	75	LOW	Pass
15	20175	1732.5	Q16	75	LOW	Pass
20	20050	1720	QPSK	100	LOW	Pass
20	20050	1720	Q16	100	LOW	Pass
20	20300	1745	QPSK	100	LOW	Pass
20	20300	1745	Q16	100	LOW	Pass
20	20175	1732.5	QPSK	100	LOW	Pass
20	20175	1732.5	Q16	100	LOW	Pass

Band 5:

Bandwidth	UL Channel	Frequency	Modulation	RB Size	RB Offset	Judgment
1.4	20470	824.7	QPSK	6	LOW	Pass
1.4	20470	824.7	Q16	6	LOW	Pass
1.4	20525	836.5	QPSK	6	LOW	Pass
1.4	20525	836.5	Q16	6	LOW	Pass
1.4	20643	848.3	QPSK	6	LOW	Pass
1.4	20643	848.3	Q16	6	LOW	Pass
3	20415	825.5	QPSK	15	LOW	Pass
3	20415	825.5	Q16	15	LOW	Pass
3	20525	836.5	QPSK	15	LOW	Pass
3	20525	836.5	Q16	15	LOW	Pass
3	20635	847.5	QPSK	15	LOW	Pass
3	20635	847.5	Q16	15	LOW	Pass
5	20425	826.5	QPSK	25	LOW	Pass
5	20425	826.5	Q16	25	LOW	Pass
5	20525	836.5	QPSK	25	LOW	Pass
5	20525	836.5	Q16	25	LOW	Pass
5	20625	846.5	QPSK	25	LOW	Pass
5	20625	846.5	Q16	25	LOW	Pass
10	20450	829	QPSK	50	LOW	Pass
10	20450	829	Q16	50	LOW	Pass
10	20525	836.5	QPSK	50	LOW	Pass



Bandwidth	UL Channel	Frequency	Modulation	RB Size	RB Offset	Judgment
10	20525	836.5	Q16	50	LOW	Pass
10	20600	844	QPSK	50	LOW	Pass
10	20600	844	Q16	50	LOW	Pass

Band 7:

Bandwidth	UL Channel	Frequency	Modulation	RB Size	RB Offset	Judgment
5	20775	2502.5	QPSK	25	LOW	Pass
5	20775	2502.5	Q16	25	LOW	Pass
5	21425	2567.5	QPSK	25	LOW	Pass
5	21425	2567.5	Q16	25	LOW	Pass
5	21100	2535	QPSK	25	LOW	Pass
5	21100	2535	QPSK	25	LOW	Pass
10	20800	2505	QPSK	50	LOW	Pass
10	20800	2505	Q16	50	LOW	Pass
10	21400	2565	QPSK	50	LOW	Pass
10	21400	2565	Q16	50	LOW	Pass
10	21100	2535	QPSK	50	LOW	Pass
10	21100	2535	Q16	50	LOW	Pass
15	20825	2507.5	QPSK	75	LOW	Pass
15	20825	2507.5	Q16	75	LOW	Pass
15	21375	2562.5	QPSK	75	LOW	Pass
15	21375	2562.5	Q16	75	LOW	Pass
15	21100	2535	QPSK	75	LOW	Pass
15	21100	2535	Q16	75	LOW	Pass
20	20850	2510	QPSK	100	LOW	Pass
20	20850	2510	Q16	100	LOW	Pass
20	21350	2560	QPSK	100	LOW	Pass
20	21350	2560	Q16	100	LOW	Pass
20	21100	2535	QPSK	100	LOW	Pass
20	21100	2535	Q16	100	LOW	Pass

Band 12:

Bandwidth	UL Channel	Frequency	Modulation	RB Size	RB Offset	Judgment
1.4	23017	699.7	QPSK	6	LOW	Pass
1.4	23017	699.7	Q16	6	LOW	Pass
1.4	23095	707.5	QPSK	6	LOW	Pass
1.4	23095	707.5	Q16	6	LOW	Pass
1.4	23173	715.3	QPSK	6	LOW	Pass
1.4	23173	715.3	Q16	6	LOW	Pass
3	23025	700.5	QPSK	15	LOW	Pass
3	23025	700.5	Q16	15	LOW	Pass
3	23095	707.5	QPSK	15	LOW	Pass
3	23095	707.5	Q16	15	LOW	Pass
3	23165	714.5	QPSK	15	LOW	Pass
3	23165	714.5	Q16	15	LOW	Pass
5	23035	701.5	QPSK	25	LOW	Pass
5	23035	701.5	Q16	25	LOW	Pass
5	23095	707.5	QPSK	25	LOW	Pass
5	23095	707.5	Q16	25	LOW	Pass



Bandwidth	UL Channel	Frequency	Modulation	RB Size	RB Offset	Judgment
5	23155	713.5	QPSK	25	LOW	Pass
5	23155	713.5	Q16	25	LOW	Pass
10	23060	704	QPSK	50	LOW	Pass
10	23060	704	Q16	50	LOW	Pass
10	23095	707.5	QPSK	50	LOW	Pass
10	23095	707.5	Q16	50	LOW	Pass
10	23130	711	QPSK	50	LOW	Pass
10	23130	711	Q16	50	LOW	Pass

Band 13:

Bandwidth	UL Channel	Frequency	Modulation	RB Size	RB Offset	Judgment
5	23205	779.5	QPSK	25	LOW	Pass
5	23205	779.5	Q16	25	LOW	Pass
5	23230	782	QPSK	25	LOW	Pass
5	23230	782	Q16	25	LOW	Pass
5	23255	784.5	QPSK	25	LOW	Pass
5	23255	784.5	Q16	25	LOW	Pass
10	23230	782	QPSK	50	LOW	Pass
10	23230	782	Q16	50	LOW	Pass

Band 17:

Bandwidth	UL Channel	Frequency	Modulation	RB Size	RB Offset	Judgment
5	23755	706.5	QPSK	25	LOW	Pass
5	23755	706.5	Q16	25	LOW	Pass
5	23790	710	QPSK	25	LOW	Pass
5	23790	710	Q16	25	LOW	Pass
5	23825	713.5	QPSK	25	LOW	Pass
5	23825	713.5	Q16	25	LOW	Pass
10	23780	709	QPSK	50	LOW	Pass
10	23780	709	Q16	50	LOW	Pass
10	23790	710	QPSK	50	LOW	Pass
10	23790	710	Q16	50	LOW	Pass
10	23800	711	QPSK	50	LOW	Pass
10	23800	711	Q16	50	LOW	Pass

Band 38:

Bandwidth	UL Channel	Frequency	Modulation	RB Size	RB Offset	Judgment
5	37775	2572.5	QPSK	25	LOW	Pass
5	37775	2572.5	Q16	25	LOW	Pass
5	38000	2595	QPSK	25	LOW	Pass
5	38000	2595	Q16	25	LOW	Pass
5	38225	2617.5	QPSK	25	LOW	Pass
5	38225	2617.5	Q16	25	LOW	Pass
10	37800	2575	QPSK	50	LOW	Pass
10	37800	2575	Q16	50	LOW	Pass
10	38000	2595	QPSK	50	LOW	Pass
10	38000	2595	Q16	50	LOW	Pass
10	38200	2615	QPSK	50	LOW	Pass



Bandwidth	UL Channel	Frequency	Modulation	RB Size	RB Offset	Judgment
10	38200	2615	Q16	50	LOW	Pass
15	37825	2577.5	QPSK	75	LOW	Pass
15	37825	2577.5	Q16	75	LOW	Pass
15	38000	2595	QPSK	75	LOW	Pass
15	38000	2595	Q16	75	LOW	Pass
15	38175	2612.5	QPSK	75	LOW	Pass
15	38175	2612.5	Q16	75	LOW	Pass
20	37850	2580	QPSK	100	LOW	Pass
20	37850	2580	Q16	100	LOW	Pass
20	38000	2595	QPSK	100	LOW	Pass
20	38000	2595	Q16	100	LOW	Pass
20	38150	2610	QPSK	100	LOW	Pass
20	38150	2610	Q16	100	LOW	Pass

Band 41:

Bandwidth	UL Channel	Frequency	Modulation	RB Size	RB Offset	Judgment
5	39675	2498.5	QPSK	25	LOW	Pass
5	39675	2498.5	Q16	25	LOW	Pass
5	40620	2593	QPSK	25	LOW	Pass
5	40620	2593	Q16	25	LOW	Pass
5	41565	2687.5	QPSK	25	LOW	Pass
5	41565	2687.5	Q16	25	LOW	Pass
10	39700	2501	QPSK	50	LOW	Pass
10	39700	2501	Q16	50	LOW	Pass
10	40620	2593	QPSK	50	LOW	Pass
10	40620	2593	Q16	50	LOW	Pass
10	41540	2685	QPSK	50	LOW	Pass
10	41540	2685	Q16	50	LOW	Pass
15	39725	2503.5	QPSK	75	LOW	Pass
15	39725	2503.5	Q16	75	LOW	Pass
15	40620	2593	QPSK	75	LOW	Pass
15	40620	2593	Q16	75	LOW	Pass
15	41515	2682.5	QPSK	75	LOW	Pass
15	41515	2682.5	Q16	75	LOW	Pass
20	39750	2506	QPSK	100	LOW	Pass
20	39750	2506	Q16	100	LOW	Pass
20	40620	2593	QPSK	100	LOW	Pass
20	40620	2593	Q16	100	LOW	Pass
20	41490	2680	QPSK	100	LOW	Pass
20	41490	2680	Q16	100	LOW	Pass

Band 42(3450-3550Mhz):

Bandwidth	UL Channel	Frequency	Modulation	RB Size	RB Offset	Judgment
5	42115	3452.5	QPSK	25	LOW	Pass
5	42115	3452.5	Q16	25	LOW	Pass
5	42590	3500	QPSK	25	LOW	Pass
5	42590	3500	Q16	25	LOW	Pass
5	43065	3547.5	QPSK	25	LOW	Pass
5	43065	3547.5	Q16	25	LOW	Pass



Bandwidth	UL Channel	Frequency	Modulation	RB Size	RB Offset	Judgment
10	42140	3455	QPSK	50	LOW	Pass
10	42140	3455	Q16	50	LOW	Pass
10	42590	3500	QPSK	50	LOW	Pass
10	42590	3500	Q16	50	LOW	Pass
10	43040	3545	QPSK	50	LOW	Pass
10	43040	3545	Q16	50	LOW	Pass
15	42165	3457.5	QPSK	75	LOW	Pass
15	42165	3457.5	Q16	75	LOW	Pass
15	42590	3500	QPSK	75	LOW	Pass
15	42590	3500	Q16	75	LOW	Pass
15	43015	3542.5	QPSK	75	LOW	Pass
15	43015	3542.5	Q16	75	LOW	Pass
20	42190	3460	QPSK	100	LOW	Pass
20	42190	3460	Q16	100	LOW	Pass
20	42590	3500	QPSK	100	LOW	Pass
20	42590	3500	Q16	100	LOW	Pass
20	42990	3540	QPSK	100	LOW	Pass
20	42990	3540	Q16	100	LOW	Pass

Band 66:

Bandwidth	UL Channel	Frequency	Modulation	RB Size	RB Offset	Judgment
1.4	131979	1710.7	QPSK	6	LOW	Pass
1.4	131979	1710.7	Q16	6	LOW	Pass
1.4	132322	1745	QPSK	6	LOW	Pass
1.4	132322	1745	Q16	6	LOW	Pass
1.4	132665	1779.3	QPSK	6	LOW	Pass
1.4	132665	1779.3	Q16	6	LOW	Pass
3	131987	1711.5	QPSK	15	LOW	Pass
3	131987	1711.5	Q16	15	LOW	Pass
3	132322	1745	QPSK	15	LOW	Pass
3	132322	1745	Q16	15	LOW	Pass
3	132657	1778.5	QPSK	15	LOW	Pass
3	132657	1778.5	Q16	15	LOW	Pass
5	131997	1712.5	QPSK	25	LOW	Pass
5	131997	1712.5	Q16	25	LOW	Pass
5	132322	1745	QPSK	25	LOW	Pass
5	132322	1745	Q16	25	LOW	Pass
5	132647	1777.5	QPSK	25	LOW	Pass
5	132647	1777.5	Q16	25	LOW	Pass
10	132022	1715	QPSK	50	LOW	Pass
10	132022	1715	Q16	50	LOW	Pass
10	132322	1745	QPSK	50	LOW	Pass
10	132322	1745	Q16	50	LOW	Pass
10	132622	1775	QPSK	50	LOW	Pass
10	132622	1775	Q16	50	LOW	Pass
15	132047	1717.5	QPSK	75	LOW	Pass
15	132047	1717.5	Q16	75	LOW	Pass
15	132322	1745	QPSK	75	LOW	Pass
15	132322	1745	Q16	75	LOW	Pass
15	132597	1772.5	QPSK	75	LOW	Pass

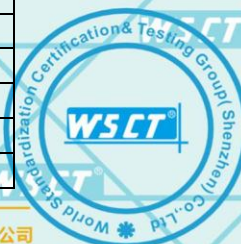

Bandwidth	UL Channel	Frequency	Modulation	RB Size	RB Offset	Judgment
15	132597	1772.5	Q16	75	LOW	Pass
20	132072	1720	QPSK	100	LOW	Pass
20	132072	1720	Q16	100	LOW	Pass
20	132322	1745	QPSK	100	LOW	Pass
20	132322	1745	Q16	100	LOW	Pass
20	132572	1770	QPSK	100	LOW	Pass
20	132572	1770	Q16	100	LOW	Pass

NR n5

Bandwidth	UL Channel	Frequency	Modulation	RB Size	RB Offset	Judgment
10	165800	829	BPSK	50	LOW	Pass
10	165800	829	QPSK	50	LOW	Pass
10	165800	829	16QAM	50	LOW	Pass
10	165800	829	64QAM	50	LOW	Pass
10	165800	829	256QAM	50	LOW	Pass
10	167300	836.5	BPSK	50	LOW	Pass
10	167300	836.5	QPSK	50	LOW	Pass
10	167300	836.5	16QAM	50	LOW	Pass
10	167300	836.5	64QAM	50	LOW	Pass
10	167300	836.5	256QAM	50	LOW	Pass
10	168800	844	BPSK	50	LOW	Pass
10	168800	844	QPSK	50	LOW	Pass
10	168800	844	16QAM	50	LOW	Pass
10	168800	844	64QAM	50	LOW	Pass
10	168800	844	256QAM	50	LOW	Pass
15	166300	831.5	BPSK	75	LOW	Pass
15	166300	831.5	QPSK	75	LOW	Pass
15	166300	831.5	16QAM	75	LOW	Pass
15	166300	831.5	64QAM	75	LOW	Pass
15	166300	831.5	256QAM	75	LOW	Pass
15	167300	836.5	BPSK	75	LOW	Pass
15	167300	836.5	QPSK	75	LOW	Pass
15	167300	836.5	16QAM	75	LOW	Pass
15	167300	836.5	64QAM	75	LOW	Pass
15	167300	836.5	256QAM	75	LOW	Pass
15	168300	841.5	BPSK	75	LOW	Pass
15	168300	841.5	QPSK	75	LOW	Pass
15	168300	841.5	16QAM	75	LOW	Pass
15	168300	841.5	64QAM	75	LOW	Pass
15	168300	841.5	256QAM	75	LOW	Pass
20	166800	834	BPSK	100	LOW	Pass
20	166800	834	QPSK	100	LOW	Pass
20	166800	834	16QAM	100	LOW	Pass
20	166800	834	64QAM	100	LOW	Pass
20	166800	834	256QAM	100	LOW	Pass
20	167300	836.5	BPSK	100	LOW	Pass
20	167300	836.5	QPSK	100	LOW	Pass
20	167300	836.5	16QAM	100	LOW	Pass
20	167300	836.5	64QAM	100	LOW	Pass
20	167300	836.5	256QAM	100	LOW	Pass
20	167800	839	BPSK	100	LOW	Pass
20	167800	839	QPSK	100	LOW	Pass
20	167800	839	16QAM	100	LOW	Pass
20	167800	839	64QAM	100	LOW	Pass
20	167800	839	256QAM	100	LOW	Pass



NR n7

Bandwidth	UL Channel	Frequency	Modulation	RB Size	RB Offset	Judgment
10	501000	2505	BPSK	50	LOW	Pass
10	501000	2505	QPSK	50	LOW	Pass
10	501000	2505	16QAM	50	LOW	Pass
10	501000	2505	64QAM	50	LOW	Pass
10	501000	2505	256QAM	50	LOW	Pass
10	507000	2535	BPSK	50	LOW	Pass
10	507000	2535	QPSK	50	LOW	Pass
10	507000	2535	16QAM	50	LOW	Pass
10	507000	2535	64QAM	50	LOW	Pass
10	507000	2535	256QAM	50	LOW	Pass
10	513000	2565	BPSK	50	LOW	Pass
10	513000	2565	QPSK	50	LOW	Pass
10	513000	2565	16QAM	50	LOW	Pass
10	513000	2565	64QAM	50	LOW	Pass
10	513000	2565	256QAM	50	LOW	Pass
15	501500	2507.5	BPSK	75	LOW	Pass
15	501500	2507.5	QPSK	75	LOW	Pass
15	501500	2507.5	16QAM	75	LOW	Pass
15	501500	2507.5	64QAM	75	LOW	Pass
15	501500	2507.5	256QAM	75	LOW	Pass
15	507000	2535	BPSK	75	LOW	Pass
15	507000	2535	QPSK	75	LOW	Pass
15	507000	2535	16QAM	75	LOW	Pass
15	507000	2535	64QAM	75	LOW	Pass
15	507000	2535	256QAM	75	LOW	Pass
15	512500	2562.5	BPSK	75	LOW	Pass
15	512500	2562.5	QPSK	75	LOW	Pass
15	512500	2562.5	16QAM	75	LOW	Pass
15	512500	2562.5	64QAM	75	LOW	Pass
15	512500	2562.5	256QAM	75	LOW	Pass
20	502000	2510	BPSK	100	LOW	Pass
20	502000	2510	QPSK	100	LOW	Pass
20	502000	2510	16QAM	100	LOW	Pass
20	502000	2510	64QAM	100	LOW	Pass
20	502000	2510	256QAM	100	LOW	Pass
20	507000	2535	BPSK	100	LOW	Pass
20	507000	2535	QPSK	100	LOW	Pass
20	507000	2535	16QAM	100	LOW	Pass
20	507000	2535	64QAM	100	LOW	Pass
20	507000	2535	256QAM	100	LOW	Pass
20	512000	2560	BPSK	100	LOW	Pass
20	512000	2560	QPSK	100	LOW	Pass
20	512000	2560	16QAM	100	LOW	Pass
20	512000	2560	64QAM	100	LOW	Pass
20	512000	2560	256QAM	100	LOW	Pass



Bandwidth	UL Channel	Frequency	Modulation	RB Size	RB Offset	Judgment
10	140800	704	BPSK	50	LOW	Pass
10	140800	704	QPSK	50	LOW	Pass
10	140800	704	16QAM	50	LOW	Pass
10	140800	704	64QAM	50	LOW	Pass
10	140800	704	256QAM	50	LOW	Pass
10	141500	707.5	BPSK	50	LOW	Pass
10	141500	707.5	QPSK	50	LOW	Pass
10	141500	707.5	16QAM	50	LOW	Pass
10	141500	707.5	64QAM	50	LOW	Pass
10	141500	707.5	256QAM	50	LOW	Pass
10	142200	711	BPSK	50	LOW	Pass
10	142200	711	QPSK	50	LOW	Pass
10	142200	711	16QAM	50	LOW	Pass
10	142200	711	64QAM	50	LOW	Pass
10	142200	711	256QAM	50	LOW	Pass
15	141300	706.5	BPSK	75	LOW	Pass
15	141300	706.5	QPSK	75	LOW	Pass
15	141300	706.5	16QAM	75	LOW	Pass
15	141300	706.5	64QAM	75	LOW	Pass
15	141300	706.5	256QAM	75	LOW	Pass
15	141500	707.5	BPSK	75	LOW	Pass
15	141500	707.5	QPSK	75	LOW	Pass
15	141500	707.5	16QAM	75	LOW	Pass
15	141500	707.5	64QAM	75	LOW	Pass
15	141500	707.5	256QAM	75	LOW	Pass
15	141700	708.5	BPSK	75	LOW	Pass
15	141700	708.5	QPSK	75	LOW	Pass
15	141700	708.5	16QAM	75	LOW	Pass
15	141700	708.5	64QAM	75	LOW	Pass
15	141700	708.5	256QAM	75	LOW	Pass



NR n38:

Bandwidth	UL Channel	Frequency	Modulation	RB Size	RB Offset	Judgment
10	515000	2575	BPSK	50	LOW	Pass
10	515000	2575	QPSK	50	LOW	Pass
10	515000	2575	16QAM	50	LOW	Pass
10	515000	2575	64QAM	50	LOW	Pass
10	515000	2575	256QAM	50	LOW	Pass
10	519000	2595	BPSK	50	LOW	Pass
10	519000	2595	QPSK	50	LOW	Pass
10	519000	2595	16QAM	50	LOW	Pass
10	519000	2595	64QAM	50	LOW	Pass
10	519000	2595	256QAM	50	LOW	Pass
10	523000	2615	BPSK	50	LOW	Pass
10	523000	2615	QPSK	50	LOW	Pass
10	523000	2615	16QAM	50	LOW	Pass
10	523000	2615	64QAM	50	LOW	Pass
10	523000	2615	256QAM	50	LOW	Pass
15	515500	2577.5	BPSK	75	LOW	Pass
15	515500	2577.5	QPSK	75	LOW	Pass
15	515500	2577.5	16QAM	75	LOW	Pass
15	515500	2577.5	64QAM	75	LOW	Pass
15	515500	2577.5	256QAM	75	LOW	Pass
15	519000	2595	BPSK	75	LOW	Pass
15	519000	2595	QPSK	75	LOW	Pass
15	519000	2595	16QAM	75	LOW	Pass
15	519000	2595	64QAM	75	LOW	Pass
15	519000	2595	256QAM	75	LOW	Pass
15	522500	2612.5	BPSK	75	LOW	Pass
15	522500	2612.5	QPSK	75	LOW	Pass
15	522500	2612.5	16QAM	75	LOW	Pass
15	522500	2612.5	64QAM	75	LOW	Pass
15	522500	2612.5	256QAM	75	LOW	Pass
20	522500	2580	BPSK	100	LOW	Pass
20	522500	2580	QPSK	100	LOW	Pass
20	522500	2580	16QAM	100	LOW	Pass
20	522500	2580	64QAM	100	LOW	Pass
20	522500	2580	256QAM	100	LOW	Pass
20	519000	2595	BPSK	100	LOW	Pass
20	519000	2595	QPSK	100	LOW	Pass
20	519000	2595	16QAM	100	LOW	Pass
20	519000	2595	64QAM	100	LOW	Pass
20	519000	2595	256QAM	100	LOW	Pass
20	522000	2610	BPSK	100	LOW	Pass
20	522000	2610	QPSK	100	LOW	Pass
20	522000	2610	16QAM	100	LOW	Pass
20	522000	2610	64QAM	100	LOW	Pass
20	522000	2610	256QAM	100	LOW	Pass



NR n41:

Bandwidth	UL Channel	Frequency	Modulation	RB Size	RB Offset	Judgment
20	501204	2506	BPSK	50	LOW	Pass
20	501204	2506	QPSK	50	LOW	Pass
20	501204	2506	16QAM	50	LOW	Pass
20	501204	2506	64QAM	50	LOW	Pass
20	501204	2506	256QAM	50	LOW	Pass
20	518598	2593	BPSK	50	LOW	Pass
20	518598	2593	QPSK	50	LOW	Pass
20	518598	2593	16QAM	50	LOW	Pass
20	518598	2593	64QAM	50	LOW	Pass
20	518598	2593	256QAM	50	LOW	Pass
20	535998	2680	BPSK	50	LOW	Pass
20	535998	2680	QPSK	50	LOW	Pass
20	535998	2680	16QAM	50	LOW	Pass
20	535998	2680	64QAM	50	LOW	Pass
20	535998	2680	256QAM	50	LOW	Pass
50	504204	2521	BPSK	75	LOW	Pass
50	504204	2521	QPSK	75	LOW	Pass
50	504204	2521	16QAM	75	LOW	Pass
50	504204	2521	64QAM	75	LOW	Pass
50	504204	2521	256QAM	75	LOW	Pass
50	518598	2593	BPSK	75	LOW	Pass
50	518598	2593	QPSK	75	LOW	Pass
50	518598	2593	16QAM	75	LOW	Pass
50	518598	2593	64QAM	75	LOW	Pass
50	518598	2593	256QAM	75	LOW	Pass
50	532998	2665	BPSK	75	LOW	Pass
50	532998	2665	QPSK	75	LOW	Pass
50	532998	2665	16QAM	75	LOW	Pass
50	532998	2665	64QAM	75	LOW	Pass
50	532998	2665	256QAM	75	LOW	Pass
100	509202	2546	BPSK	100	LOW	Pass
100	509202	2546	QPSK	100	LOW	Pass
100	509202	2546	16QAM	100	LOW	Pass
100	509202	2546	64QAM	100	LOW	Pass
100	509202	2546	256QAM	100	LOW	Pass
100	518598	2593	BPSK	100	LOW	Pass
100	518598	2593	QPSK	100	LOW	Pass
100	518598	2593	16QAM	100	LOW	Pass
100	518598	2593	64QAM	100	LOW	Pass
100	518598	2593	256QAM	100	LOW	Pass
100	528000	2640	BPSK	100	LOW	Pass
100	528000	2640	QPSK	100	LOW	Pass
100	528000	2640	16QAM	100	LOW	Pass
100	528000	2640	64QAM	100	LOW	Pass
100	528000	2640	256QAM	100	LOW	Pass



NR n66:

Bandwidth	UL Channel	Frequency	Modulation	RB Size	RB Offset	Judgment
10	343000	1715	BPSK	50	LOW	Pass
10	343000	1715	QPSK	50	LOW	Pass
10	343000	1715	16QAM	50	LOW	Pass
10	343000	1715	64QAM	50	LOW	Pass
10	343000	1715	256QAM	50	LOW	Pass
10	349000	1745	BPSK	50	LOW	Pass
10	349000	1745	QPSK	50	LOW	Pass
10	349000	1745	16QAM	50	LOW	Pass
10	349000	1745	64QAM	50	LOW	Pass
10	349000	1745	256QAM	50	LOW	Pass
10	355000	1775	BPSK	50	LOW	Pass
10	355000	1775	QPSK	50	LOW	Pass
10	355000	1775	16QAM	50	LOW	Pass
10	355000	1775	64QAM	50	LOW	Pass
10	355000	1775	256QAM	50	LOW	Pass
20	344000	1720	BPSK	75	LOW	Pass
20	344000	1720	QPSK	75	LOW	Pass
20	344000	1720	16QAM	75	LOW	Pass
20	344000	1720	64QAM	75	LOW	Pass
20	344000	1720	256QAM	75	LOW	Pass
20	349000	1745	BPSK	75	LOW	Pass
20	349000	1745	QPSK	75	LOW	Pass
20	349000	1745	16QAM	75	LOW	Pass
20	349000	1745	64QAM	75	LOW	Pass
20	349000	1745	256QAM	75	LOW	Pass
20	354000	1770	BPSK	75	LOW	Pass
20	354000	1770	QPSK	75	LOW	Pass
20	354000	1770	16QAM	75	LOW	Pass
20	354000	1770	64QAM	75	LOW	Pass
20	354000	1770	256QAM	75	LOW	Pass
40	346000	1730	BPSK	100	LOW	Pass
40	346000	1730	QPSK	100	LOW	Pass
40	346000	1730	16QAM	100	LOW	Pass
40	346000	1730	64QAM	100	LOW	Pass
40	346000	1730	256QAM	100	LOW	Pass
40	349000	1745	BPSK	100	LOW	Pass
40	349000	1745	QPSK	100	LOW	Pass
40	349000	1745	16QAM	100	LOW	Pass
40	349000	1745	64QAM	100	LOW	Pass
40	349000	1760	256QAM	100	LOW	Pass
40	349000	1760	BPSK	100	LOW	Pass
40	349000	1760	QPSK	100	LOW	Pass
40	349000	1760	16QAM	100	LOW	Pass
40	349000	1760	64QAM	100	LOW	Pass
40	349000	1760	256QAM	100	LOW	Pass



NR n77(3450-3550Mhz):

Bandwidth	UL Channel	Frequency	Modulation	RB Size	RB Offset	Judgment
10	630334	3455	BPSK	50	LOW	Pass
10	630334	3455	QPSK	50	LOW	Pass
10	630334	3455	16QAM	50	LOW	Pass
10	630334	3455	64QAM	50	LOW	Pass
10	630334	3455	256QAM	50	LOW	Pass
10	633334	3500	BPSK	50	LOW	Pass
10	633334	3500	QPSK	50	LOW	Pass
10	633334	3500	16QAM	50	LOW	Pass
10	633334	3500	64QAM	50	LOW	Pass
10	633334	3500	256QAM	50	LOW	Pass
10	636332	3545	BPSK	50	LOW	Pass
10	636332	3545	QPSK	50	LOW	Pass
10	636332	3545	16QAM	50	LOW	Pass
10	636332	3545	64QAM	50	LOW	Pass
10	636332	3545	256QAM	50	LOW	Pass
50	631668	3475	BPSK	75	LOW	Pass
50	631668	3475	QPSK	75	LOW	Pass
50	631668	3475	16QAM	75	LOW	Pass
50	631668	3475	64QAM	75	LOW	Pass
50	631668	3475	256QAM	75	LOW	Pass
50	633334	3500	BPSK	75	LOW	Pass
50	633334	3500	QPSK	75	LOW	Pass
50	633334	3500	16QAM	75	LOW	Pass
50	633334	3500	64QAM	75	LOW	Pass
50	633334	3500	256QAM	75	LOW	Pass
50	635000	3525	BPSK	75	LOW	Pass
50	635000	3525	QPSK	75	LOW	Pass
50	635000	3525	16QAM	75	LOW	Pass
50	635000	3525	64QAM	75	LOW	Pass
50	635000	3525	256QAM	75	LOW	Pass
100	633334	3500	BPSK	100	LOW	Pass
100	633334	3500	QPSK	100	LOW	Pass
100	633334	3500	16QAM	100	LOW	Pass
100	633334	3500	64QAM	100	LOW	Pass
100	633334	3500	256QAM	100	LOW	Pass

NR n77(3700-3980Mhz):

Bandwidth	UL Channel	Frequency	Modulation	RB Size	RB Offset	Judgment
10	647000	3705	BPSK	50	LOW	Pass
10	647000	3705	QPSK	50	LOW	Pass
10	647000	3705	16QAM	50	LOW	Pass
10	647000	3705	64QAM	50	LOW	Pass
10	647000	3705	256QAM	50	LOW	Pass
10	650000	3750	BPSK	50	LOW	Pass
10	656000	3890	QPSK	50	LOW	Pass
10	650000	3750	16QAM	50	LOW	Pass
10	650000	3750	64QAM	50	LOW	Pass
10	656000	3890	256QAM	50	LOW	Pass



Bandwidth	UL Channel	Frequency	Modulation	RB Size	RB Offset	Judgment
10	665000	3975	BPSK	50	LOW	Pass
10	665000	3975	QPSK	50	LOW	Pass
10	665000	3975	16QAM	50	LOW	Pass
10	665000	3975	64QAM	50	LOW	Pass
10	665000	3975	256QAM	50	LOW	Pass
50	648334	3725	BPSK	75	LOW	Pass
50	648334	3725	QPSK	75	LOW	Pass
50	648334	3725	16QAM	75	LOW	Pass
50	648334	3725	64QAM	75	LOW	Pass
50	648334	3725	256QAM	75	LOW	Pass
50	656000	3890	BPSK	75	LOW	Pass
50	656000	3890	QPSK	75	LOW	Pass
50	656000	3890	16QAM	75	LOW	Pass
50	656000	3890	64QAM	75	LOW	Pass
50	656000	3890	256QAM	75	LOW	Pass
50	663666	3955	BPSK	75	LOW	Pass
50	663666	3955	QPSK	75	LOW	Pass
50	663666	3955	16QAM	75	LOW	Pass
50	663666	3955	64QAM	75	LOW	Pass
50	663666	3955	256QAM	75	LOW	Pass
100	650000	3750	BPSK	100	LOW	Pass
100	650000	3750	QPSK	100	LOW	Pass
100	650000	3750	16QAM	100	LOW	Pass
100	650000	3750	64QAM	100	LOW	Pass
100	650000	3750	256QAM	100	LOW	Pass
100	656000	3890	BPSK	100	LOW	Pass
100	656000	3890	QPSK	100	LOW	Pass
100	656000	3890	16QAM	100	LOW	Pass
100	656000	3890	64QAM	100	LOW	Pass
100	656000	3890	256QAM	100	LOW	Pass
100	662000	3930	BPSK	100	LOW	Pass
100	662000	3930	QPSK	100	LOW	Pass
100	662000	3930	16QAM	100	LOW	Pass
100	662000	3930	64QAM	100	LOW	Pass
100	662000	3930	256QAM	100	LOW	Pass

NR n78(3450-3550Mhz):

Bandwidth	UL Channel	Frequency	Modulation	RB Size	RB Offset	Judgment
10	630334	3455	BPSK	50	LOW	Pass
10	630334	3455	QPSK	50	LOW	Pass
10	630334	3455	16QAM	50	LOW	Pass
10	630334	3455	64QAM	50	LOW	Pass
10	630334	3455	256QAM	50	LOW	Pass
10	633334	3500	BPSK	50	LOW	Pass
10	633334	3500	QPSK	50	LOW	Pass
10	633334	3500	16QAM	50	LOW	Pass
10	633334	3500	64QAM	50	LOW	Pass
10	633334	3500	256QAM	50	LOW	Pass
10	636332	3545	BPSK	50	LOW	Pass
10	636332	3545	QPSK	50	LOW	Pass



Bandwidth	UL Channel	Frequency	Modulation	RB Size	RB Offset	Judgment
10	636332	3545	16QAM	50	LOW	Pass
10	636332	3545	64QAM	50	LOW	Pass
10	636332	3545	256QAM	50	LOW	Pass
50	631668	3475	BPSK	75	LOW	Pass
50	631668	3475	QPSK	75	LOW	Pass
50	631668	3475	16QAM	75	LOW	Pass
50	631668	3475	64QAM	75	LOW	Pass
50	631668	3475	256QAM	75	LOW	Pass
50	633334	3500	BPSK	75	LOW	Pass
50	633334	3500	QPSK	75	LOW	Pass
50	633334	3500	16QAM	75	LOW	Pass
50	633334	3500	64QAM	75	LOW	Pass
50	633334	3500	256QAM	75	LOW	Pass
50	635000	3525	BPSK	75	LOW	Pass
50	635000	3525	QPSK	75	LOW	Pass
50	635000	3525	16QAM	75	LOW	Pass
50	635000	3525	64QAM	75	LOW	Pass
50	635000	3525	256QAM	75	LOW	Pass
100	633334	3500	BPSK	100	LOW	Pass
100	633334	3500	QPSK	100	LOW	Pass
100	633334	3500	16QAM	100	LOW	Pass
100	633334	3500	64QAM	100	LOW	Pass
100	633334	3500	256QAM	100	LOW	Pass

NR n78(3700-3800Mhz):

Bandwidth	UL Channel	Frequency	Modulation	RB Size	RB Offset	Judgment
10	647000	3705	BPSK	50	LOW	Pass
10	647000	3705	QPSK	50	LOW	Pass
10	647000	3705	16QAM	50	LOW	Pass
10	647000	3705	64QAM	50	LOW	Pass
10	647000	3705	256QAM	50	LOW	Pass
10	650000	3750	BPSK	50	LOW	Pass
10	650000	3750	QPSK	50	LOW	Pass
10	650000	3750	16QAM	50	LOW	Pass
10	650000	3750	64QAM	50	LOW	Pass
10	650000	3750	256QAM	50	LOW	Pass
10	653000	3775	BPSK	50	LOW	Pass
10	653000	3775	QPSK	50	LOW	Pass
10	653000	3775	16QAM	50	LOW	Pass
10	653000	3775	64QAM	50	LOW	Pass
10	653000	3775	256QAM	50	LOW	Pass
50	648334	3725	BPSK	75	LOW	Pass
50	648334	3725	QPSK	75	LOW	Pass
50	648334	3725	16QAM	75	LOW	Pass
50	648334	3725	64QAM	75	LOW	Pass
50	648334	3725	256QAM	75	LOW	Pass
50	650000	3750	BPSK	75	LOW	Pass
50	650000	3750	QPSK	75	LOW	Pass
50	650000	3750	16QAM	75	LOW	Pass
50	650000	3750	64QAM	75	LOW	Pass

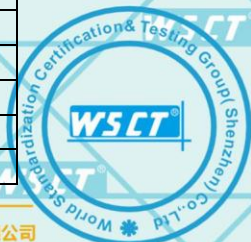

Bandwidth	UL Channel	Frequency	Modulation	RB Size	RB Offset	Judgment
50	650000	3750	256QAM	75	LOW	Pass
50	651666	3775	BPSK	75	LOW	Pass
50	651666	3775	QPSK	75	LOW	Pass
50	651666	3775	16QAM	75	LOW	Pass
50	651666	3775	64QAM	75	LOW	Pass
50	651666	3775	256QAM	75	LOW	Pass
100	650000	3750	BPSK	100	LOW	Pass
100	650000	3750	QPSK	100	LOW	Pass
100	650000	3750	16QAM	100	LOW	Pass
100	650000	3750	64QAM	100	LOW	Pass
100	650000	3750	256QAM	100	LOW	Pass

Test Plot(s)



Conducted method

Test limit:

The spurious (unwanted) emission limits specified in the individual FCC rule parts applicable to licensed digital transmitters (typically referred to under the heading ‘emission limits’) normally apply to any and all emissions that are present outside of the authorized frequency band/block and apply to emissions in both the out-of-band and spurious domains. In some rule parts, the unwanted emission limits are specified by an emission mask that defines the applicable limit as a function of the frequency range relative to the authorized frequency block.

Typically, unwanted emissions are required by the licensed rule parts to be attenuated below the transmitter power by a factor of at least $X + 10\log(P)$ dB, where P represents the transmitter power expressed in watts and X is a specified scalar value (e.g., 43). This specification can be interpreted in one of two equivalent ways. First, the required attenuation can be construed to be relative to the mean carrier power, with the resultant of the equation $X + 10\log(P)$ being expressed in dBc (dB relative to the maximum carrier power). Alternatively, the specification can be interpreted as an absolute limit when the specified attenuation is actually subtracted from the maximum permissible transmitter power [i.e., $10\log(P) - \{X + 10\log(P)\}$], resulting in an absolute level of -X dBW [or (-X + 30) dBm]. See section 4.

Test procedure:

The RF output of the transceiver was connected to a spectrum analyzer and simulator through appropriate attenuation. The resolution bandwidth of the spectrum analyzer was set at 100 kHz below 1 GHz and 1 MHz above 1 GHz. Sufficient scans were taken to show any out of band emissions up to 10th harmonics.

Conducted Emission Test-Up:

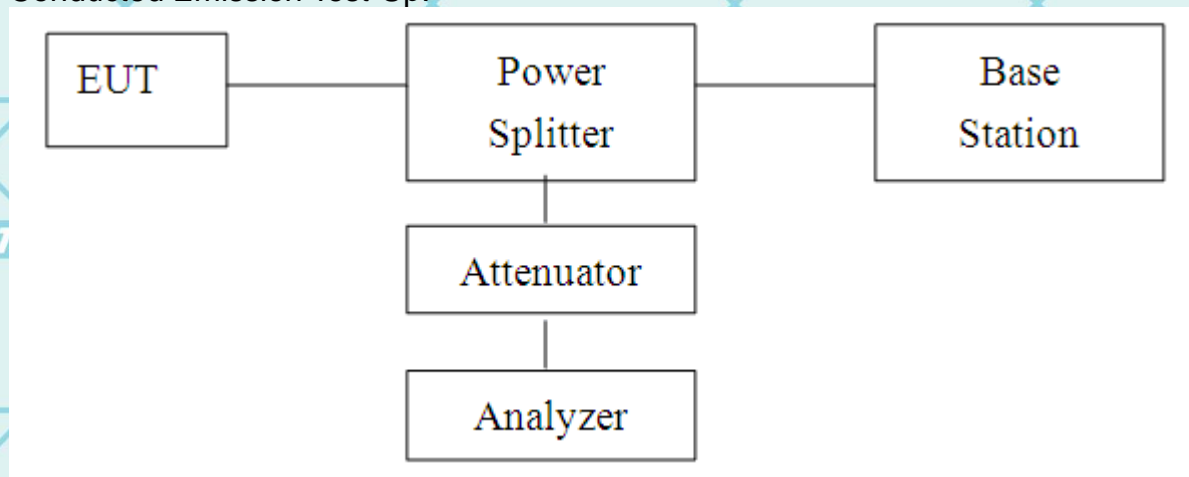

Radiated method

Test limit:

The spurious (unwanted) emission limits specified in the individual FCC rule parts applicable to licensed digital transmitters (typically referred to under the heading 'emission limits') normally apply to any and all emissions that are present outside of the authorized frequency band/block and apply to emissions in both the out-of-band and spurious domains. In some rule parts, the unwanted emission limits are specified by an emission mask that defines the applicable limit as a function of the frequency range relative to the authorized frequency block.

Typically, unwanted emissions are required by the licensed rule parts to be attenuated below the transmitter power by a factor of at least $X + 10\log(P)$ dB, where P represents the transmitter power expressed in watts and X is a specified scalar value (e.g., 43). This specification can be interpreted in one of two equivalent ways. First, the required attenuation can be construed to be relative to the mean carrier power, with the resultant of the equation $X + 10\log(P)$ being expressed in dBc (dB relative to the maximum carrier power). Alternatively, the specification can be interpreted as an absolute limit when the specified attenuation is actually subtracted from the maximum permissible transmitter power [i.e., $10\log(P) - \{X + 10\log(P)\}$], resulting in an absolute level of -X dBW [or $(-X + 30)$ dBm]. See section 4.

Test procedure:

The radiated emission tests were performed in the 3m Semi- Anechoic Chamber test site. The resolution bandwidth of the spectrum analyzer was set at 100 kHz below 1 GHz and 1 MHz above 1 GHz. Sufficient scans were taken to show any out of band emissions up to 10th harmonics.

Test setup:

(A) Radiated Emission Test-Up Frequency 30MHz~1GHz

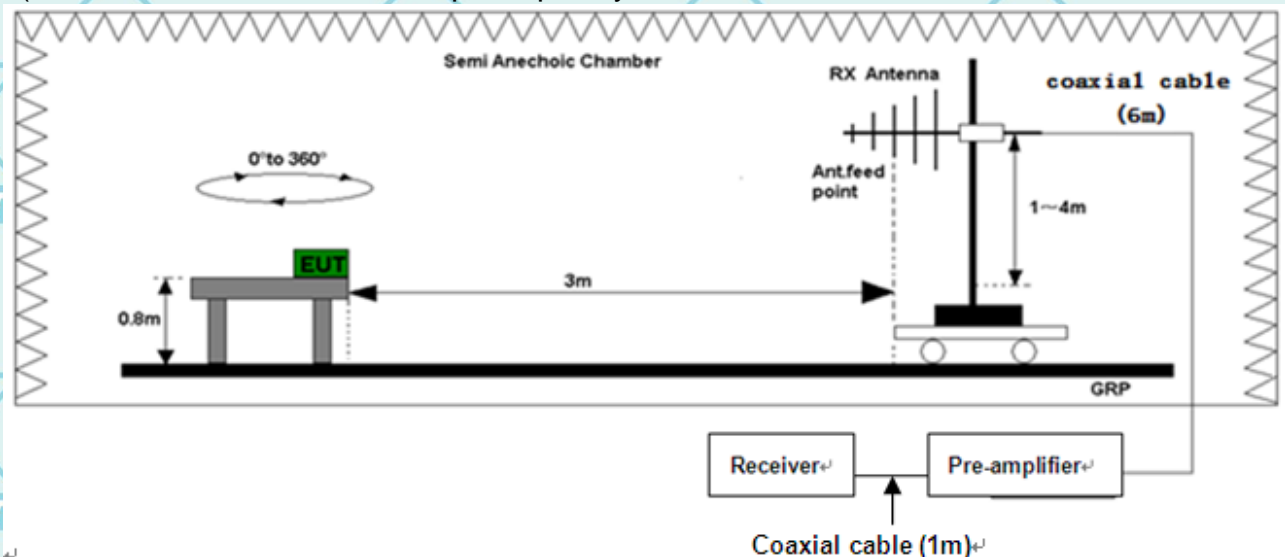

(B) Radiated Emission Test-Up Frequency Above 1GHz

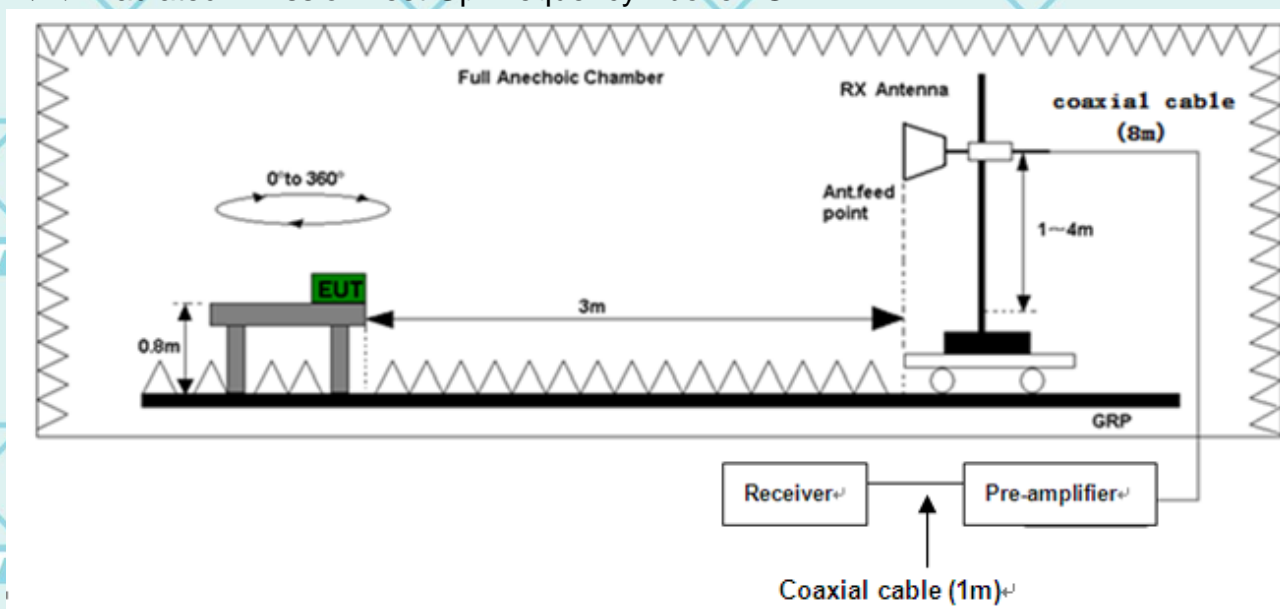

Note:

- 1, Below 30MHz no Spurious found.
- 2, UE is positioned at 3 axis at the pre-scan stage, and only the measurement of the worst caseis reported in this part.

List of final test modes:

GSM850:

Channel	UL Channel	Frequency	Judgment
Middle	190	836.6	Pass

PCS1900

Channel	UL Channel	Frequency	Judgment
Middle	661	1880	Pass

UTRA BANDS

Band 2:

Channel	UL Channel	Frequency	Judgment
Middle	9400	1880	Pass

Band 4:

Channel	UL Channel	Frequency	Judgment
Middle	1413	1732.6	Pass

Band 5:

Channel	UL Channel	Frequency	Judgment
Middle	4182	836.4	Pass



E-UTRA BANDS

This is the worst pattern data

Band 2:

Channel	Bandwidth	UL Channel	Frequency	Modulation	RB Size	RB Offset	Judgment
Middle	20	18900	1880	QPSK	100	LOW	Pass

Band 4:

Mode	Bandwidth	UL Channel	Frequency	Modulation	RB Size	RB Offset	Judgment
1	20	20300	1745	Q16	100	LOW	Pass

Band 5:

Channel	Bandwidth	UL Channel	Frequency	Modulation	RB Size	RB Offset	Judgment
Middle	10	20525	836.5	QPSK	50	LOW	Pass

Band 7:

Channel	Bandwidth	UL Channel	Frequency	Modulation	RB Size	RB Offset	Judgment
Middle	20	21350	2560	QPSK	100	LOW	Pass

Band 12:

Channel	Bandwidth	UL Channel	Frequency	Modulation	RB Size	RB Offset	Judgment
Middle	10	23095	707.5	QPSK	50	LOW	Pass

Band 13:

Channel	Bandwidth	UL Channel	Frequency	Modulation	RB Size	RB Offset	Judgment
Middle	10	23230	782	QPSK	50	LOW	Pass

Band 17:

Channel	Bandwidth	UL Channel	Frequency	Modulation	RB Size	RB Offset	Judgment
Middle	10	23790	710	QPSK	50	LOW	Pass

Band 38:

Channel	Bandwidth	UL Channel	Frequency	Modulation	RB Size	RB Offset	Judgment
Middle	20	38000	2595	QPSK	100	LOW	Pass

Band 41:

Channel	Bandwidth	UL Channel	Frequency	Modulation	RB Size	RB Offset	Judgment
Middle	20	40620	2593	QPSK	100	LOW	Pass

Band 42(3450-3550Mhz):

Channel	Bandwidth	UL Channel	Frequency	Modulation	RB Size	RB Offset	Judgment
Middle	20	42590	3500	QPSK	100	LOW	Pass

Band 66:

Channel	Bandwidth	UL Channel	Frequency	Modulation	RB Size	RB Offset	Judgment
Middle	20	132322	1745	QPSK	100	LOW	Pass



NR Bands

This is the worst pattern data

n5:

Channel	Bandwidth	UL Channel	Frequency	Modulation	RB Size	RB Offset	Judgment
Middle	20	167300	836.5	QPSK	100	LOW	Pass

n7:

Channel	Bandwidth	UL Channel	Frequency	Modulation	RB Size	RB Offset	Judgment
Middle	20	507000	2535	QPSK	100	LOW	Pass

n12:

Channel	Bandwidth	UL Channel	Frequency	Modulation	RB Size	RB Offset	Judgment
Middle	15	141500	707.5	QPSK	75	LOW	Pass

n38:

Channel	Bandwidth	UL Channel	Frequency	Modulation	RB Size	RB Offset	Judgment
Middle	20	519000	2595	QPSK	100	LOW	Pass

n41:

Channel	Bandwidth	UL Channel	Frequency	Modulation	RB Size	RB Offset	Judgment
Middle	100	518598	2593	QPSK	100	LOW	Pass

n66:

Channel	Bandwidth	UL Channel	Frequency	Modulation	RB Size	RB Offset	Judgment
Middle	40	349000	1745	QPSK	100	LOW	Pass

n77(3450-3550Mhz):

Channel	Bandwidth	UL Channel	Frequency	Modulation	RB Size	RB Offset	Judgment
Middle	100	633034	3500	QPSK	100	LOW	Pass

n77(3700-3980Mhz):

Channel	Bandwidth	UL Channel	Frequency	Modulation	RB Size	RB Offset	Judgment
Middle	100	656000	3890	QPSK	100	LOW	Pass

n78(3450-3550Mhz):

Channel	Bandwidth	UL Channel	Frequency	Modulation	RB Size	RB Offset	Judgment
Middle	100	633034	3500	QPSK	100	LOW	Pass

n78(3700-3800Mhz):

Channel	Bandwidth	UL Channel	Frequency	Modulation	RB Size	RB Offset	Judgment
Middle	100	650000	3750	QPSK	100	LOW	Pass



Test record:

Note:

1. The substitution method is used. Substitution values at each frequency are measured before and saved to the test software. A "reference path loss" is established and the AR_{pl} is the attenuation of "reference path loss", and including the gain of receive antenna, the gain of the preamplifier, the cable loss and the air loss. The measurement results are obtained as described below:

$$\text{Power} = P_{\text{Mea}} + AR_{pl}$$

2. $AR_{pl} = \text{Cable loss} + \text{Antenna gain}$



GSM850:
Horizontal:

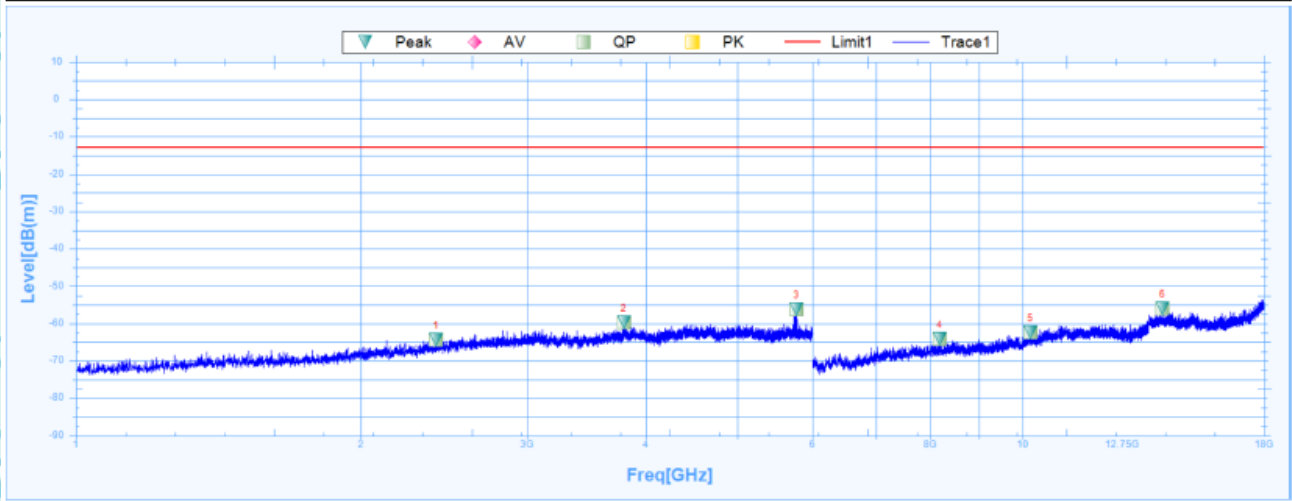

Susputed Data List

NO.	Freq. [MHz]	Level [dB(m)]	Factor [dB]	Reading [dB(m)]	Limit [dB]	Margin [dB]	Deg [°]	Polarity	Trace	Verdict
1	2401.2500	-64.45	27.26	-91.71	-13	-51.45	1.2	Horizontal	PK	Pass
2	3791.2500	-59.83	29.2	-89.03	-13	-46.83	88.9	Horizontal	PK	Pass
3	5771.2500	-56.23	32.43	-88.66	-13	-43.23	1.2	Horizontal	PK	Pass
4	8179.5000	-64.16	8.69	-72.85	-13	-51.16	36.7	Horizontal	PK	Pass
5	10197.0000	-62.42	12.97	-75.39	-13	-49.42	309.3	Horizontal	PK	Pass
6	14055.0000	-56.07	19.07	-75.14	-13	-43.07	177.8	Horizontal	PK	Pass



Vertical:

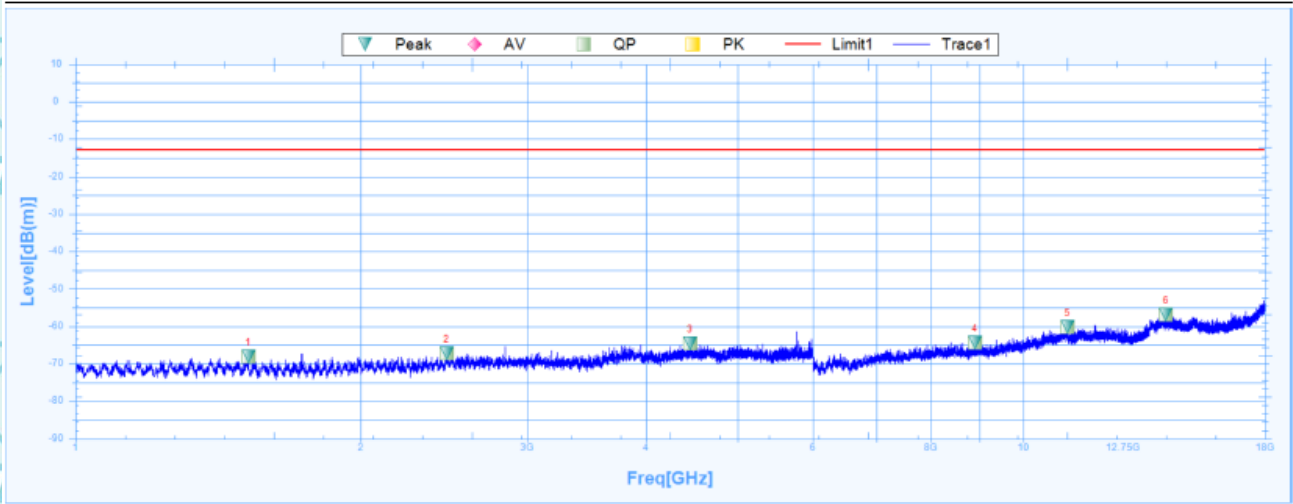

Susputed Data List

NO.	Freq. [MHz]	Level [dB(m)]	Factor [dB]	Reading [dB(m)]	Limit [dB]	Margin [dB]	Deg [°]	Polarity	Trace	Verdict
1	1521.8750	-68.19	24.98	-93.17	-13	-55.19	360	Vertical	PK	Pass
2	2463.7500	-67.23	27.48	-94.71	-13	-54.23	360	Vertical	PK	Pass
3	4453.7500	-64.67	30.52	-95.19	-13	-51.67	360	Vertical	PK	Pass
4	8892.0000	-64.35	9.74	-74.09	-13	-51.35	11.8	Vertical	PK	Pass
5	11139.0000	-60.21	15.82	-76.03	-13	-47.21	309.3	Vertical	PK	Pass
6	14149.5000	-56.81	18.98	-75.79	-13	-43.81	332	Vertical	PK	Pass



PCS1900:
Horizontal:

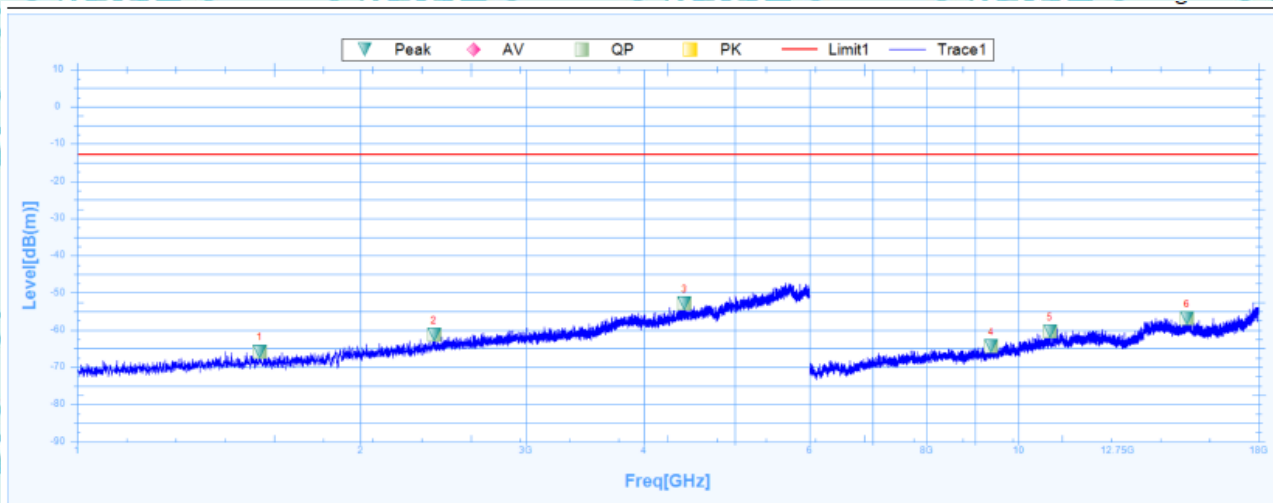

Susputed Data List

NO.	Freq. [MHz]	Level [dB(m)]	Factor [dB]	Reading [dB(m)]	Limit [dB]	Margin [dB]	Deg [°]	Polarity	Trace	Verdict
1	1563.1250	-65.8	24.94	-90.74	-13	-52.8	137.9	Horizontal	PK	Pass
2	2394.3750	-61.26	27.24	-88.5	-13	-48.26	97.4	Horizontal	PK	Pass
3	4421.2500	-52.85	30.46	-83.31	-13	-39.85	268.2	Horizontal	PK	Pass
4	9358.5000	-64.42	10.63	-75.05	-13	-51.42	213.7	Horizontal	PK	Pass
5	10800.0000	-60.31	14.77	-75.08	-13	-47.31	79.8	Horizontal	PK	Pass
6	15106.5000	-56.89	19.66	-76.55	-13	-43.89	289	Horizontal	PK	Pass



Vertical:

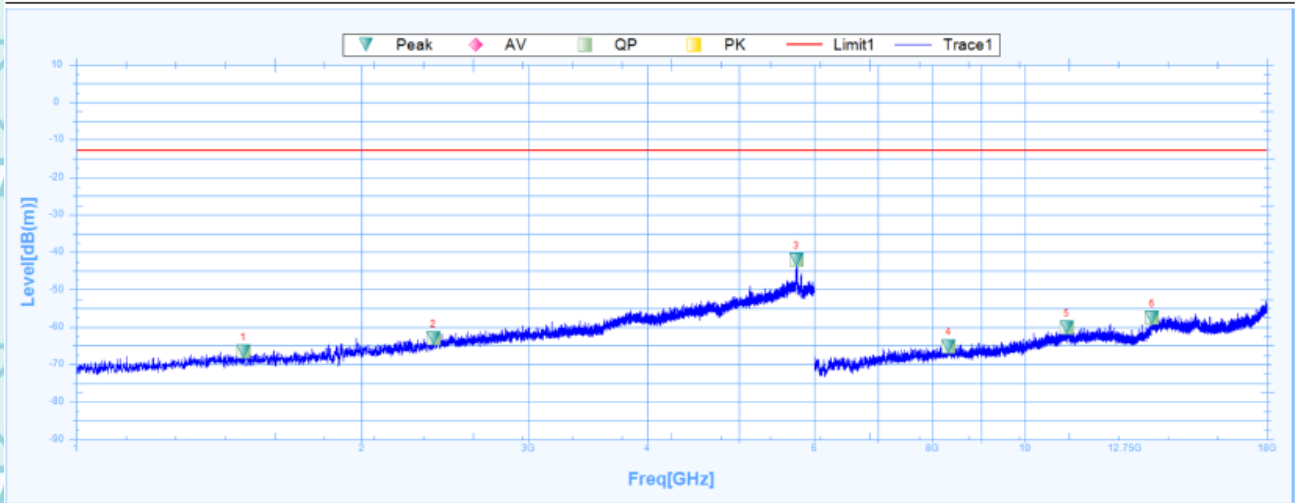

Suspected Data List

NO.	Freq. [MHz]	Level [dB(m)]	Factor [dB]	Reading [dB(m)]	Limit [dB]	Margin [dB]	Deg [°]	Polarity	Trace	Verdict
1	1500.6250	-66.66	25	-91.66	-13	-53.66	349.1	Vertical	PK	Pass
2	2380.6250	-63.08	27.19	-90.27	-13	-50.08	228.8	Vertical	PK	Pass
3	5744.3750	-42.09	32.39	-74.48	-13	-29.09	301.7	Vertical	PK	Pass
4	8313.0000	-65.14	8.96	-74.1	-13	-52.14	330.8	Vertical	PK	Pass
5	11070.0000	-60.25	15.85	-76.1	-13	-47.25	144.3	Vertical	PK	Pass
6	13618.5000	-57.46	18.03	-75.49	-13	-44.46	247.1	Vertical	PK	Pass



ULTRA BANDS
Band 2:
Horizontal:

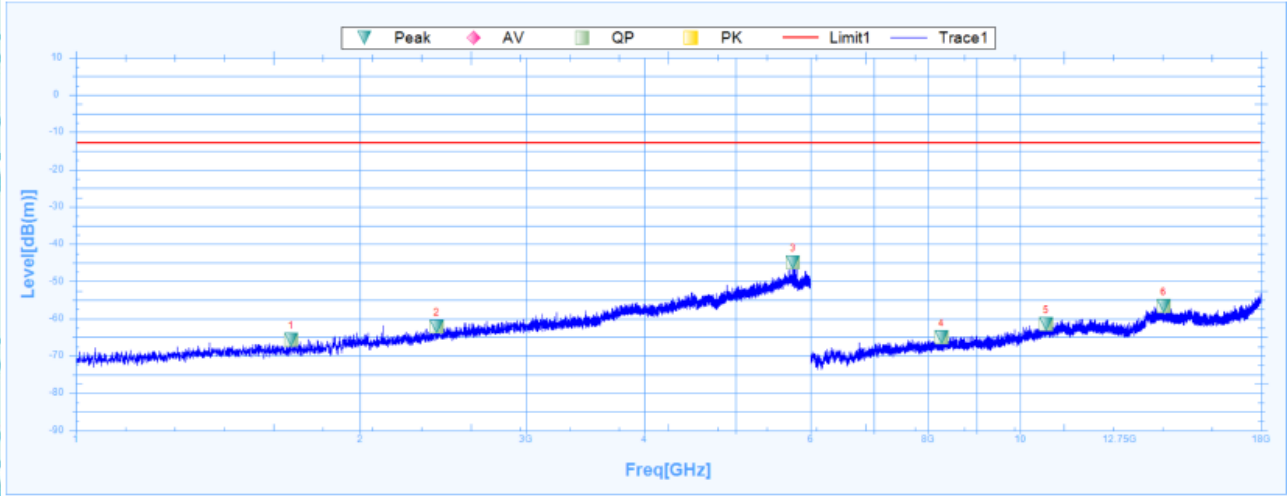

Susputed Data List

NO.	Freq. [MHz]	Level [dB(m)]	Factor [dB]	Reading [dB(m)]	Limit [dB]	Margin [dB]	Deg [°]	Polarity	Trace	Verdict
1	1689.3750	-65.76	24.94	-90.7	-13	-52.76	143.9	Horizontal	PK	Pass
2	2411.8750	-62.11	27.3	-89.41	-13	-49.11	297	Horizontal	PK	Pass
3	5751.8750	-44.84	32.4	-77.24	-13	-31.84	9.9	Horizontal	PK	Pass
4	8259.0000	-65.07	8.87	-73.94	-13	-52.07	198.2	Horizontal	PK	Pass
5	10659.0000	-61.46	14.53	-75.99	-13	-48.46	200.6	Horizontal	PK	Pass
6	14188.5000	-56.6	18.93	-75.53	-13	-43.6	192.2	Horizontal	PK	Pass



Vertical:

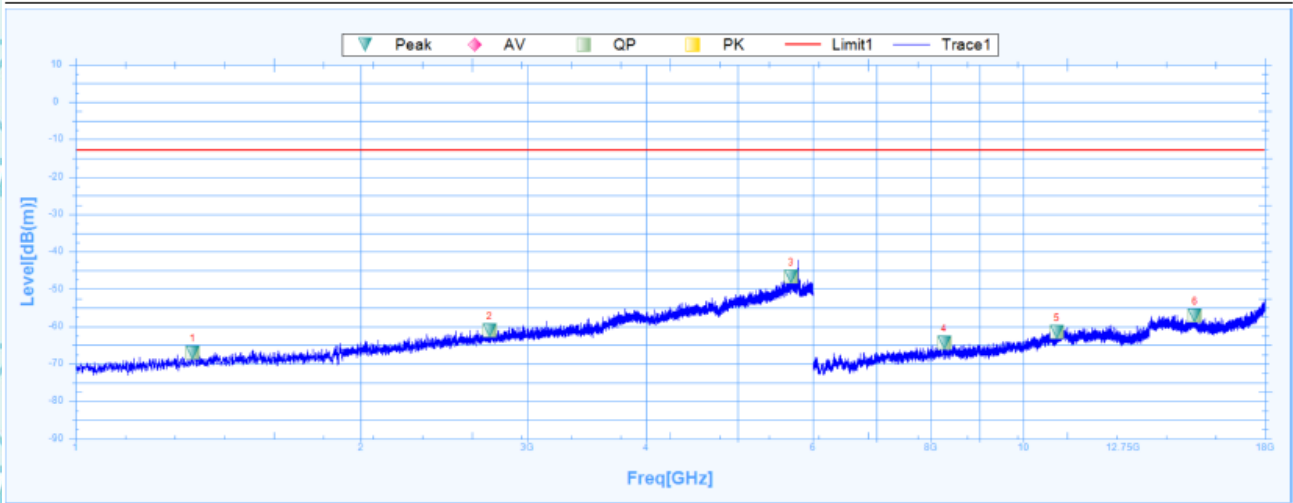

Susputed Data List

NO.	Freq. [MHz]	Level [dB(m)]	Factor [dB]	Reading [dB(m)]	Limit [dB]	Margin [dB]	Deg [°]	Polarity	Trace	Verdict
1	1329.3750	-66.97	24.85	-91.82	-13	-53.97	357.5	Vertical	PK	Pass
2	2735.6250	-60.98	27.88	-88.86	-13	-47.98	257.5	Vertical	PK	Pass
3	5692.5000	-46.68	32.31	-78.99	-13	-33.68	360	Vertical	PK	Pass
4	8254.5000	-64.42	8.87	-73.29	-13	-51.42	191	Vertical	PK	Pass
5	10854.0000	-61.47	14.87	-76.34	-13	-48.47	191	Vertical	PK	Pass
6	15184.5000	-57	19.27	-76.27	-13	-44	359	Vertical	PK	Pass



Band 4:
Horizontal:

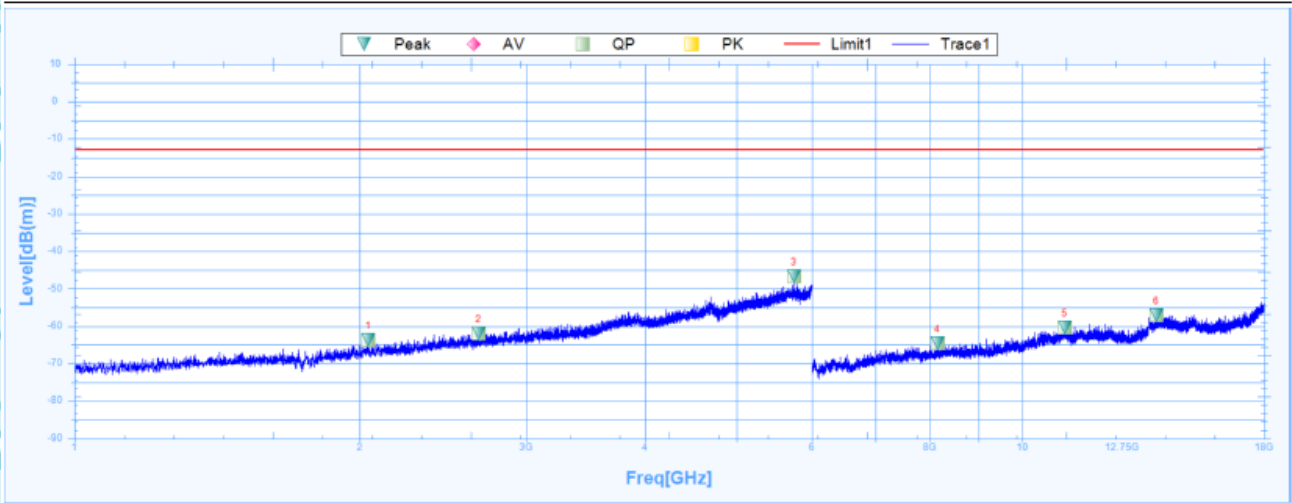

Suspected Data List

NO.	Freq. [MHz]	Level [dB(m)]	Factor [dB]	Reading [dB(m)]	Limit [dB]	Margin [dB]	Deg [°]	Polarity	Trace	Verdict
1	2041.8750	-63.7	26.04	-89.74	-13	-50.7	265.9	Horizontal	PK	Pass
2	2670.0000	-61.91	27.8	-89.71	-13	-48.91	216.9	Horizontal	PK	Pass
3	5743.7500	-46.79	32.39	-79.18	-13	-33.79	8	Horizontal	PK	Pass
4	8140.5000	-64.5	8.6	-73.1	-13	-51.5	327.3	Horizontal	PK	Pass
5	11088.0000	-60.45	15.89	-76.34	-13	-47.45	354.2	Horizontal	PK	Pass
6	13854.0000	-57.16	18.7	-75.86	-13	-44.16	113.3	Horizontal	PK	Pass



Vertical:

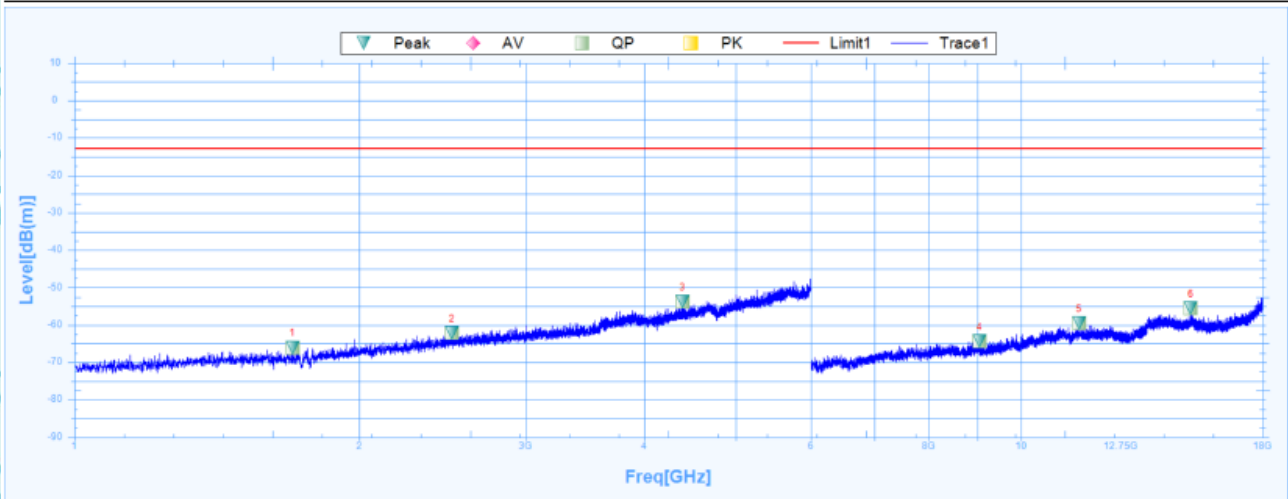

Susputed Data List

NO.	Freq. [MHz]	Level [dB(m)]	Factor [dB]	Reading [dB(m)]	Limit [dB]	Margin [dB]	Deg [°]	Polarity	Trace	Verdict
1	1699.3750	-66.03	24.95	-90.98	-13	-53.03	356.3	Vertical	PK	Pass
2	2506.2500	-62.21	27.61	-89.82	-13	-49.21	158.2	Vertical	PK	Pass
3	4393.7500	-53.84	30.41	-84.25	-13	-40.84	302.8	Vertical	PK	Pass
4	9045.0000	-64.39	9.87	-74.26	-13	-51.39	160.7	Vertical	PK	Pass
5	11523.0000	-59.56	16.19	-75.75	-13	-46.56	0.5	Vertical	PK	Pass
6	15123.0000	-55.49	19.74	-75.23	-13	-42.49	12.1	Vertical	PK	Pass



Band 5:
Horizontal:

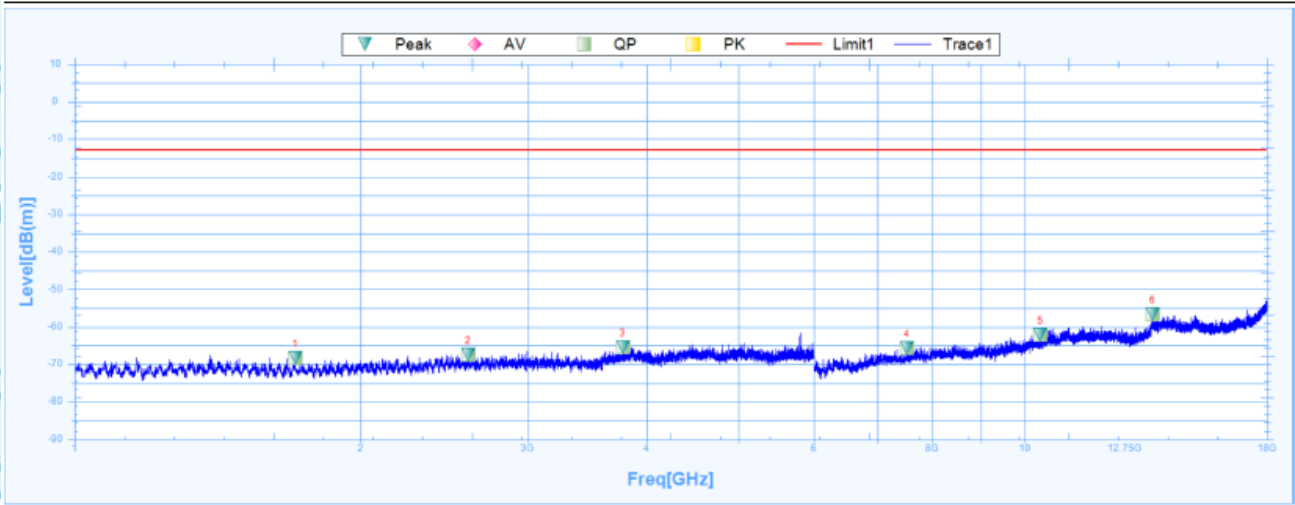

Suspected Data List

NO.	Freq. [MHz]	Level [dB(m)]	Factor [dB]	Reading [dB(m)]	Limit [dB]	Margin [dB]	Deg [°]	Polarity	Trace	Verdict
1	1706.8750	-68.39	24.95	-93.34	-13	-55.39	34.4	Horizontal	PK	Pass
2	2596.2500	-67.51	27.72	-95.23	-13	-54.51	6.3	Horizontal	PK	Pass
3	3775.6250	-65.54	29.16	-94.7	-13	-52.54	0	Horizontal	PK	Pass
4	7519.5000	-65.7	7.6	-73.3	-13	-52.7	1	Horizontal	PK	Pass
5	10393.5000	-62.1	13.57	-75.67	-13	-49.1	118.9	Horizontal	PK	Pass
6	13638.0000	-56.74	18.08	-74.82	-13	-43.74	240.8	Horizontal	PK	Pass



Vertical:

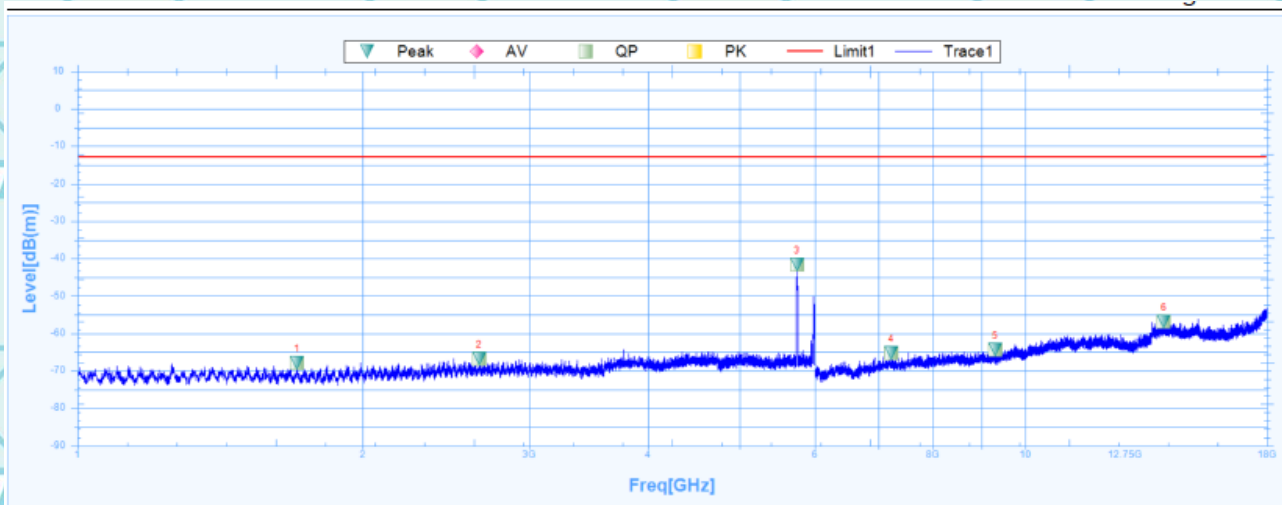

Suspected Data List										
NO.	Freq. [MHz]	Level [dB(m)]	Factor [dB]	Reading [dB(m)]	Limit [dB]	Margin [dB]	Deg [°]	Polarity	Trace	Verdict
1	1705.0000	-67.93	24.95	-92.88	-13	-54.93	0	Vertical	PK	Pass
2	2653.7500	-66.81	27.78	-94.59	-13	-53.81	271	Vertical	PK	Pass
3	5745.6250	-41.56	32.39	-73.95	-13	-28.56	30.8	Vertical	PK	Pass
4	7222.5000	-65.29	6.97	-72.26	-13	-52.29	327.9	Vertical	PK	Pass
5	9300.0000	-64.34	10.39	-74.73	-13	-51.34	257.4	Vertical	PK	Pass
6	14010.0000	-56.94	19.12	-76.06	-13	-43.94	2.3	Vertical	PK	Pass



E-UTRA BANDS

Band 2:

Horizontal:

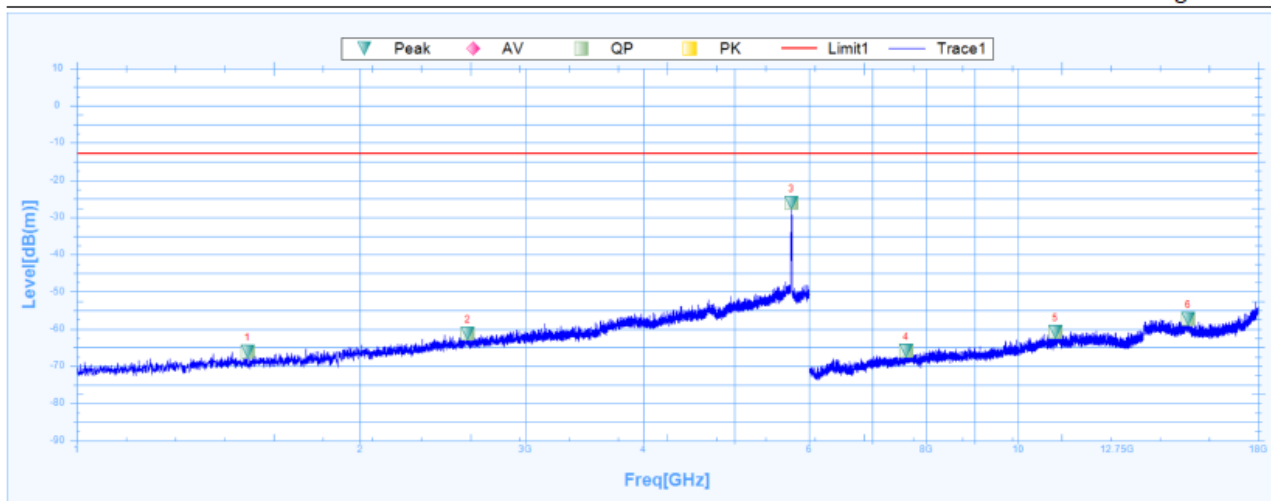

Suspected Data List										
NO.	Freq. [MHz]	Level [dB(m)]	Factor [dB]	Reading [dB(m)]	Limit [dB]	Margin [dB]	Deg [°]	Polarity	Trace	Verdict
1	1518.7500	-66.13	24.98	-91.11	-13	-53.13	275	Horizontal	PK	Pass
2	2603.7500	-61.3	27.72	-89.02	-13	-48.3	16.8	Horizontal	PK	Pass
3	5749.3750	-26.21	32.4	-58.61	-13	-13.21	114.8	Horizontal	PK	Pass
4	7605.0000	-65.9	7.94	-73.84	-13	-52.9	89	Horizontal	PK	Pass
5	10954.5000	-60.76	15.37	-76.13	-13	-47.76	34	Horizontal	PK	Pass
6	15165.0000	-57.25	19.42	-76.67	-13	-44.25	188.2	Horizontal	PK	Pass



Vertical:

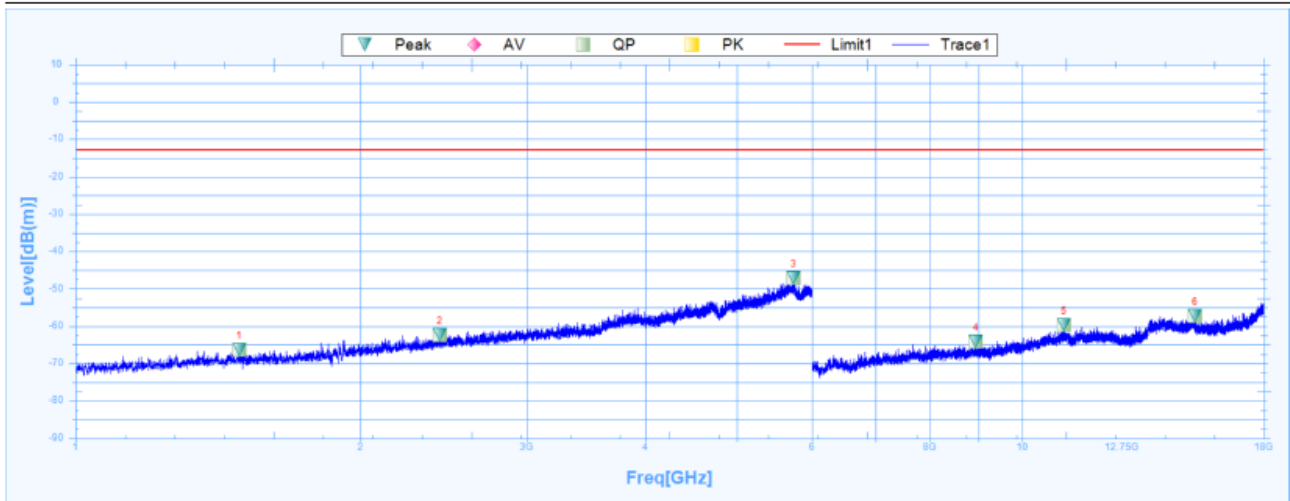

Suspected Data List

NO.	Freq. [MHz]	Level [dB(m)]	Factor [dB]	Reading [dB(m)]	Limit [dB]	Margin [dB]	Deg [°]	Polarity	Trace	Verdict
1	1488.7500	-66.38	25.01	-91.39	-13	-53.38	359	Vertical	PK	Pass
2	2426.2500	-62.29	27.35	-89.64	-13	-49.29	273.4	Vertical	PK	Pass
3	5739.3750	-47.14	32.38	-79.52	-13	-34.14	350.7	Vertical	PK	Pass
4	8941.5000	-64.23	9.81	-74.04	-13	-51.23	7.5	Vertical	PK	Pass
5	11077.5000	-59.76	15.87	-75.63	-13	-46.76	144	Vertical	PK	Pass
6	15237.0000	-57.4	18.87	-76.27	-13	-44.4	57.9	Vertical	PK	Pass



Band 4:
Horizontal:

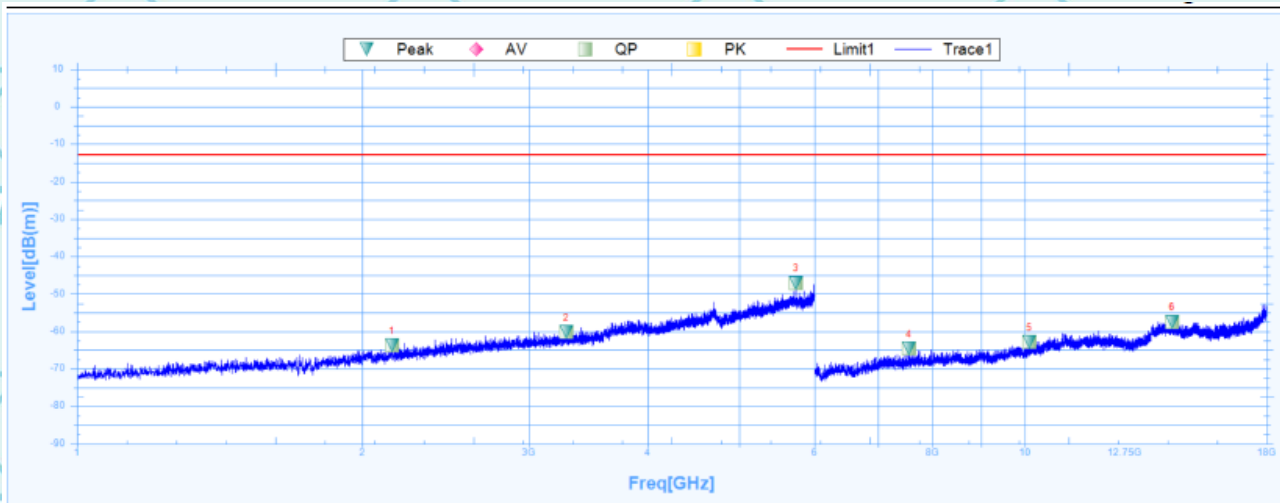

Suspected Data List

NO.	Freq. [MHz]	Level [dB(m)]	Factor [dB]	Reading [dB(m)]	Limit [dB]	Margin [dB]	Deg [°]	Polarity	Trace	Verdict
1	2149.3750	-63.61	26.41	-90.02	-13	-50.61	116.8	Horizontal	PK	Pass
2	3284.3750	-60.15	28.37	-88.52	-13	-47.15	256.6	Horizontal	PK	Pass
3	5738.7500	-47.03	32.38	-79.41	-13	-34.03	133.5	Horizontal	PK	Pass
4	7548.0000	-64.55	7.71	-72.26	-13	-51.55	228.9	Horizontal	PK	Pass
5	10117.5000	-62.77	12.71	-75.48	-13	-49.77	338.8	Horizontal	PK	Pass
6	14305.5000	-57.42	18.81	-76.23	-13	-44.42	251.6	Horizontal	PK	Pass



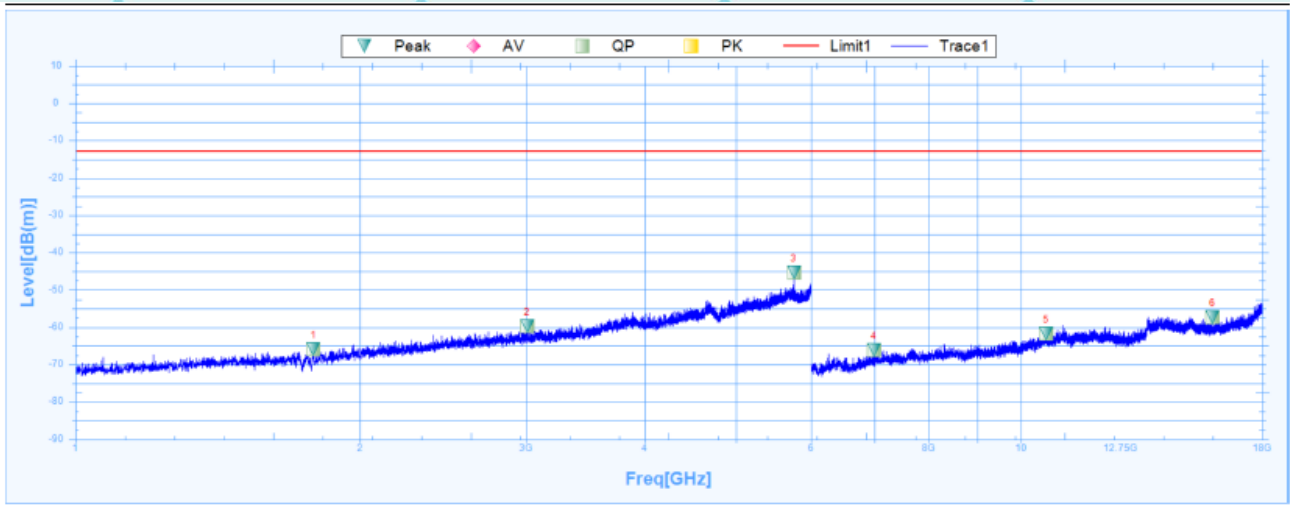

Susputed Data List

NO.	Freq. [MHz]	Level [dB(m)]	Factor [dB]	Reading [dB(m)]	Limit [dB]	Margin [dB]	Deg [°]	Polarity	Trace	Verdict
1	1786.2500	-65.84	24.99	-90.83	-13	-52.84	129.5	Vertical	PK	Pass
2	3004.3750	-59.73	28.2	-87.93	-13	-46.73	0.5	Vertical	PK	Pass
3	5752.5000	-45.33	32.4	-77.73	-13	-32.33	20	Vertical	PK	Pass
4	6990.0000	-66.21	6.32	-72.53	-13	-53.21	181.4	Vertical	PK	Pass
5	10632.0000	-61.65	14.43	-76.08	-13	-48.65	-0.1	Vertical	PK	Pass
6	15951.0000	-57.25	18.43	-75.68	-13	-44.25	23.6	Vertical	PK	Pass



Band 5:
Horizontal:

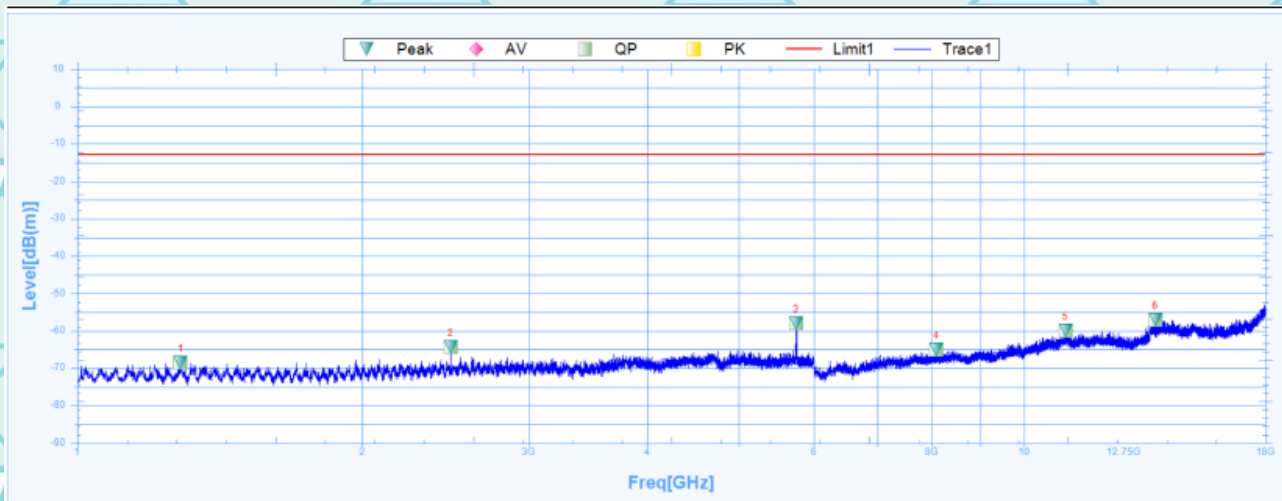

Susputed Data List

NO.	Freq. [MHz]	Level [dB(m)]	Factor [dB]	Reading [dB(m)]	Limit [dB]	Margin [dB]	Deg [°]	Polarity	Trace	Verdict
1	1285.6250	-68.53	24.7	-93.23	-13	-55.53	274.2	Horizontal	PK	Pass
2	2480.0000	-64.35	27.53	-91.88	-13	-51.35	268.3	Horizontal	PK	Pass
3	5746.8750	-57.99	32.39	-90.38	-13	-44.99	130.8	Horizontal	PK	Pass
4	8083.5000	-65.06	8.44	-73.5	-13	-52.06	263.9	Horizontal	PK	Pass
5	11062.5000	-59.87	15.81	-75.68	-13	-46.87	0	Horizontal	PK	Pass
6	13765.5000	-57.11	18.45	-75.56	-13	-44.11	278.2	Horizontal	PK	Pass



Vertical:

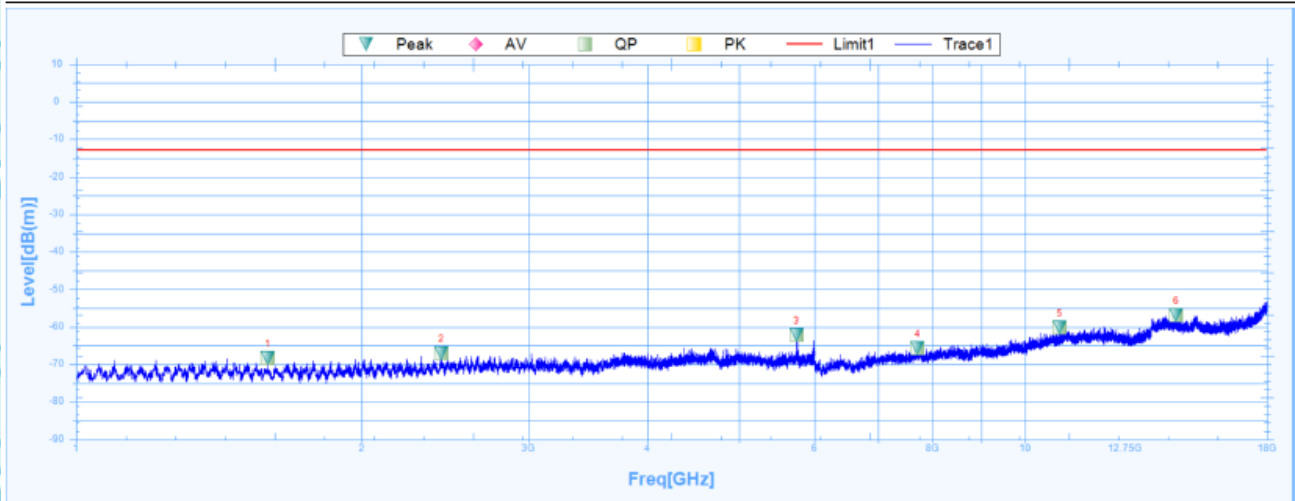

Susputed Data List

NO.	Freq. [MHz]	Level [dB(m)]	Factor [dB]	Reading [dB(m)]	Limit [dB]	Margin [dB]	Deg [°]	Polarity	Trace	Verdict
1	1592.5000	-68.29	24.91	-93.2	-13	-55.29	103.7	Vertical	PK	Pass
2	2426.2500	-67.05	27.35	-94.4	-13	-54.05	-0.1	Vertical	PK	Pass
3	5746.8750	-62.24	32.39	-94.63	-13	-49.24	346.5	Vertical	PK	Pass
4	7708.5000	-65.72	7.96	-73.68	-13	-52.72	49.5	Vertical	PK	Pass
5	10881.0000	-60.22	14.95	-75.17	-13	-47.22	324.5	Vertical	PK	Pass
6	14440.5000	-56.76	18.69	-75.45	-13	-43.76	227.7	Vertical	PK	Pass



Band 7:
Horizontal:

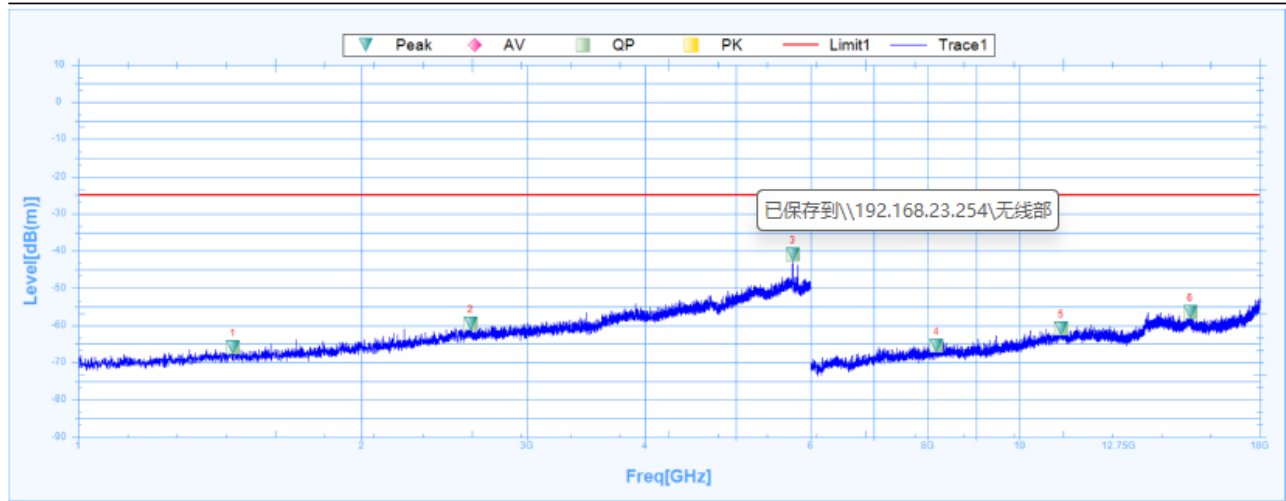

Suspected Data List

NO.	Freq. [MHz]	Level [dB(m)]	Factor [dB]	Reading [dB(m)]	Limit [dB]	Margin [dB]	Deg [°]	Polarity	Trace	Verdict
1	1460.0000	-65.91	25.04	-90.95	-25	-40.91	58.2	Horizontal	PK	Pass
2	2611.8750	-59.57	27.73	-87.3	-25	-34.57	356.1	Horizontal	PK	Pass
3	5744.3750	-40.88	32.39	-73.27	-25	-15.88	359.5	Horizontal	PK	Pass
4	8167.5000	-65.39	8.67	-74.06	-25	-40.39	357	Horizontal	PK	Pass
5	11073.0000	-60.8	15.85	-76.65	-25	-35.8	45.9	Horizontal	PK	Pass
6	15187.5000	-56.35	19.24	-75.59	-25	-31.35	6.2	Horizontal	PK	Pass



Vertical:

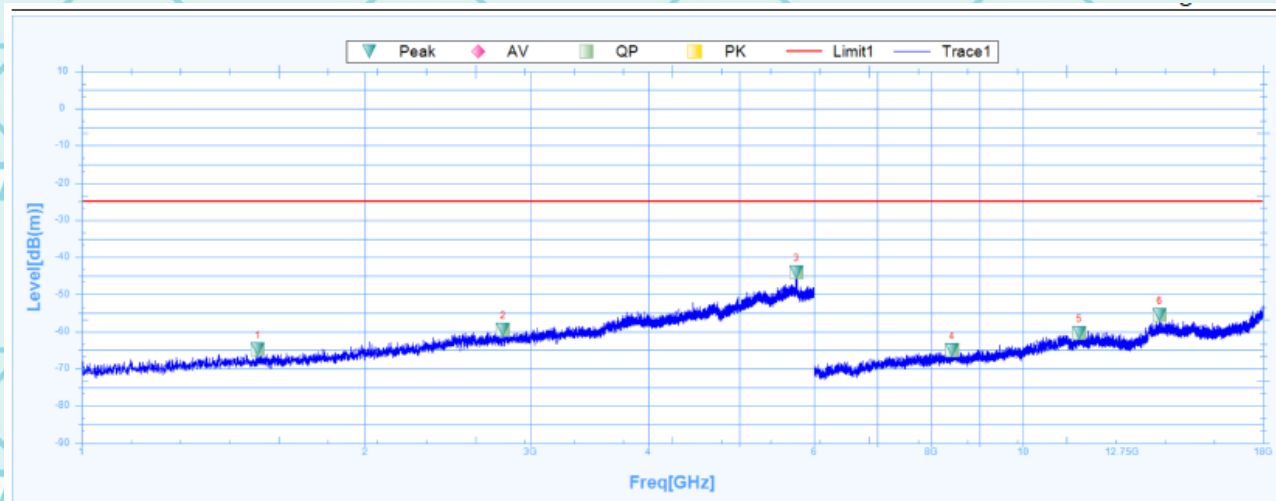

Susputed Data List

NO.	Freq. [MHz]	Level [dB(m)]	Factor [dB]	Reading [dB(m)]	Limit [dB]	Margin [dB]	Deg [°]	Polarity	Trace	Verdict
1	1539.3750	-64.75	24.96	-89.71	-25	-39.75	333.1	Vertical	PK	Pass
2	2805.0000	-59.45	27.97	-87.42	-25	-34.45	52.2	Vertical	PK	Pass
3	5748.1250	-44.13	32.4	-76.53	-25	-19.13	249.4	Vertical	PK	Pass
4	8412.0000	-64.99	9.1	-74.09	-25	-39.99	29.2	Vertical	PK	Pass
5	11479.5000	-60.48	16.07	-76.55	-25	-35.48	253.9	Vertical	PK	Pass
6	13977.0000	-55.53	19.06	-74.59	-25	-30.53	360.1	Vertical	PK	Pass



Band 12:
Horizontal:

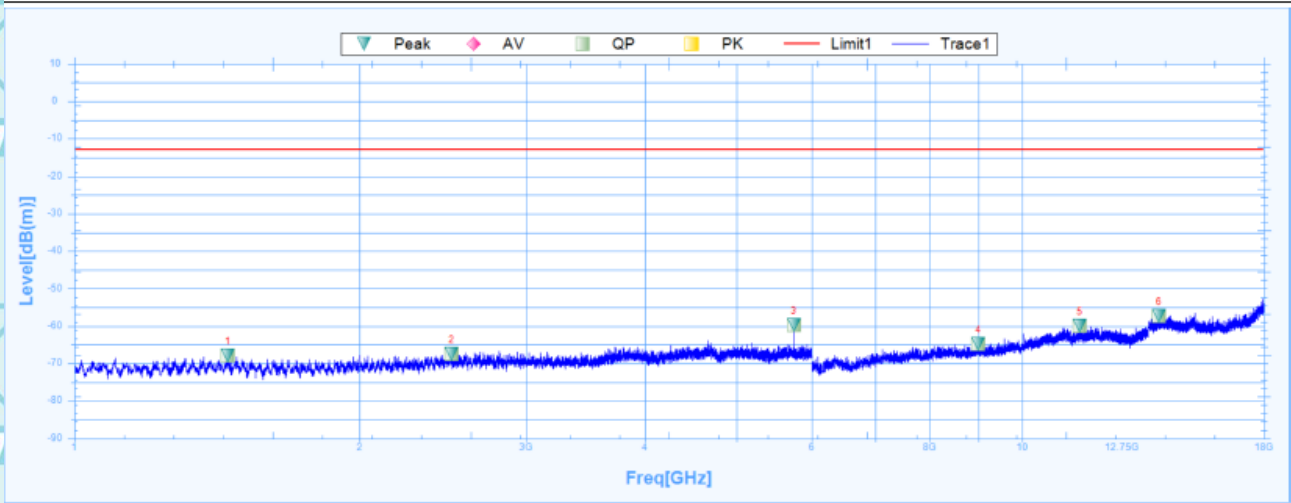

Suspected Data List										
NO.	Freq. [MHz]	Level [dB(m)]	Factor [dB]	Reading [dB(m)]	Limit [dB]	Margin [dB]	Deg [°]	Polarity	Trace	Verdict
1	1452.5000	-67.94	25.05	-92.99	-13	-54.94	0.4	Horizontal	PK	Pass
2	2501.2500	-67.44	27.6	-95.04	-13	-54.44	353.5	Horizontal	PK	Pass
3	5747.5000	-59.67	32.4	-92.07	-13	-46.67	-0.2	Horizontal	PK	Pass
4	8995.5000	-64.8	9.84	-74.64	-13	-51.8	360	Horizontal	PK	Pass
5	11509.5000	-59.86	16.15	-76.01	-13	-46.86	360	Horizontal	PK	Pass
6	13948.5000	-57.29	18.98	-76.27	-13	-44.29	17.4	Horizontal	PK	Pass



Vertical:

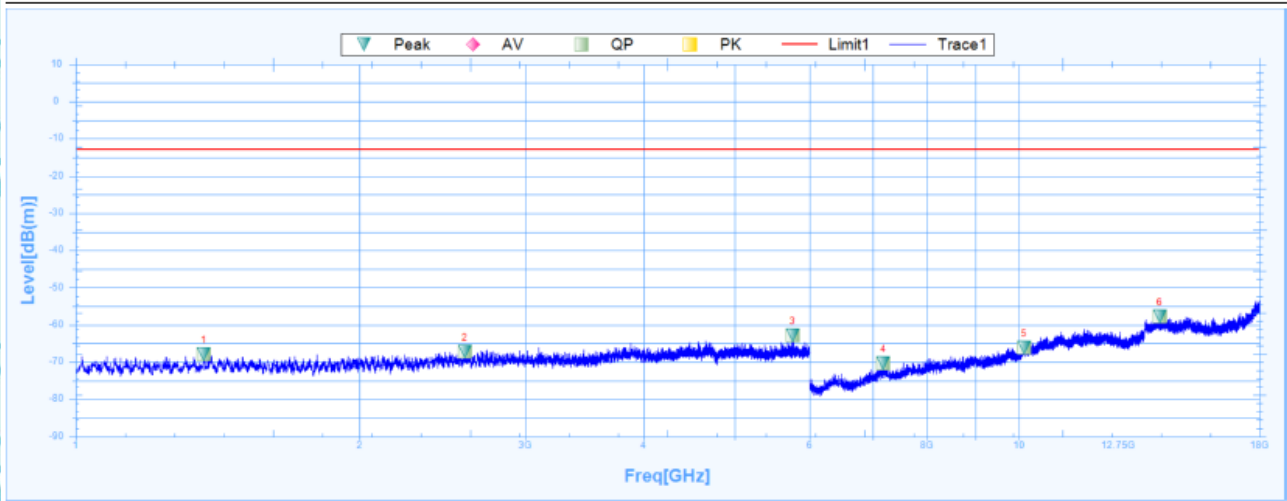

Susputed Data List

NO.	Freq. [MHz]	Level [dB(m)]	Factor [dB]	Reading [dB(m)]	Limit [dB]	Margin [dB]	Deg [°]	Polarity	Trace	Verdict
1	1367.5000	-67.9	24.99	-92.89	-13	-54.9	266.2	Vertical	PK	Pass
2	2586.8750	-67.2	27.7	-94.9	-13	-54.2	128.7	Vertical	PK	Pass
3	5757.5000	-62.77	32.41	-95.18	-13	-49.77	28.4	Vertical	PK	Pass
4	7186.5000	-70.28	7.02	-77.3	-13	-57.28	360	Vertical	PK	Pass
5	10134.0000	-66.1	12.77	-78.87	-13	-53.1	360	Vertical	PK	Pass
6	14106.0000	-57.83	19.02	-76.85	-13	-44.83	24.4	Vertical	PK	Pass



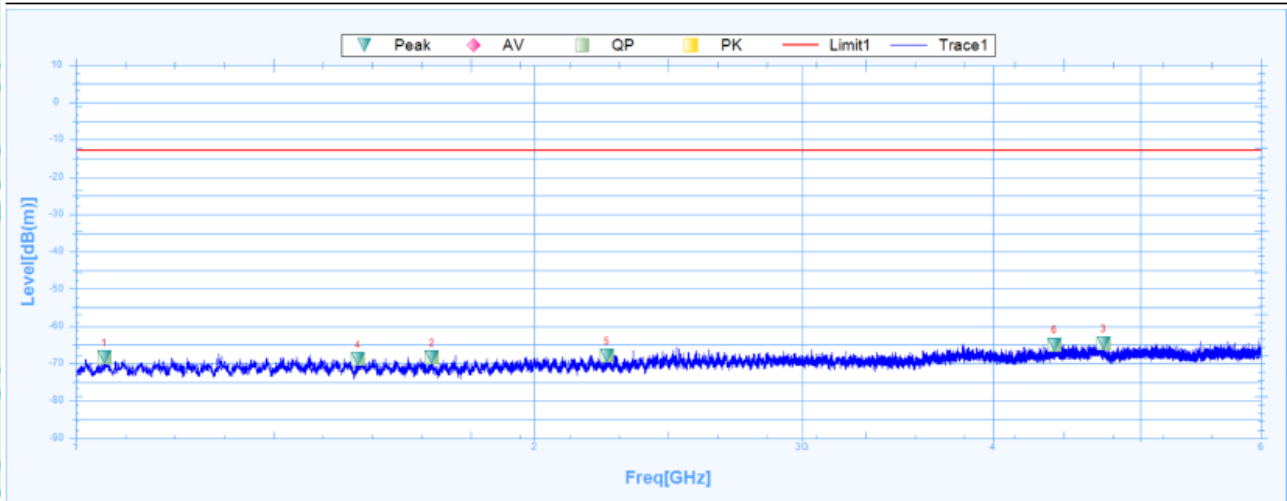

Suspected Data List

NO.	Freq. [MHz]	Level [dB(m)]	Factor [dB]	Reading [dB(m)]	Limit [dB]	Margin [dB]	Deg [°]	Polarity	Trace	Verdict
1	1043.7500	-68.27	24.32	-92.59	-13	-55.27	175.4	Horizontal	PK	Pass
2	1531.8750	-68.69	24.97	-93.66	-13	-55.69	23.8	Horizontal	PK	Pass
3	1713.7500	-68.32	24.96	-93.28	-13	-55.32	232.8	Horizontal	PK	Pass
4	2232.5000	-67.9	26.69	-94.59	-13	-54.9	0.1	Horizontal	PK	Pass
5	4389.3750	-64.92	30.4	-95.32	-13	-51.92	62	Horizontal	PK	Pass
6	4730.6250	-64.53	31.06	-95.59	-13	-51.53	71.4	Horizontal	PK	Pass



Vertical:

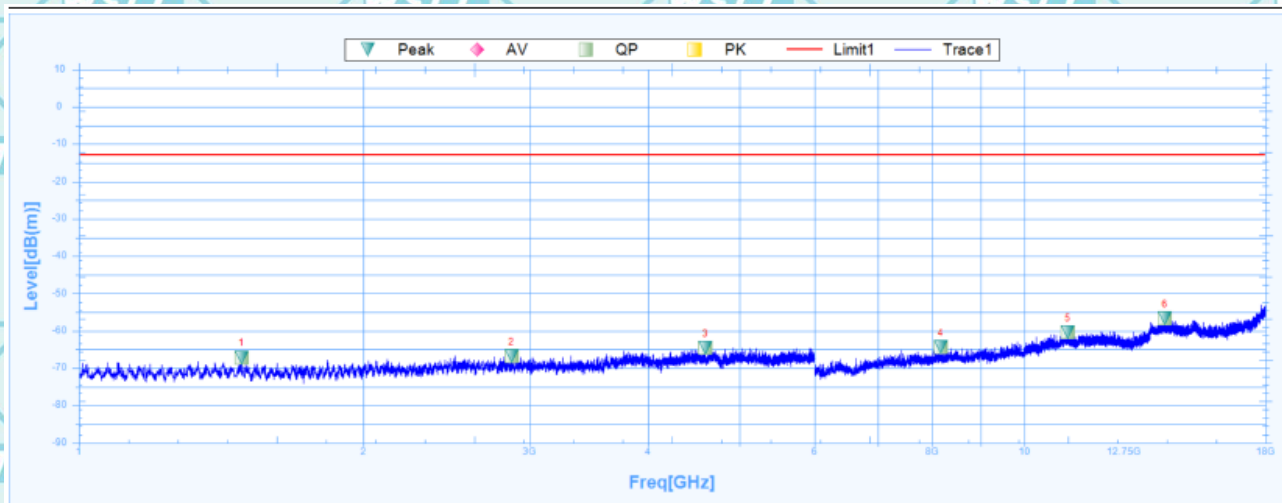

Suspected Data List

NO.	Freq. [MHz]	Level [dB(m)]	Factor [dB]	Reading [dB(m)]	Limit [dB]	Margin [dB]	Deg [°]	Polarity	Trace	Verdict
1	1486.2500	-67.13	25.01	-92.14	-13	-54.13	359.6	Vertical	PK	Pass
2	2868.7500	-66.79	28.04	-94.83	-13	-53.79	0	Vertical	PK	Pass
3	4601.2500	-64.52	30.8	-95.32	-13	-51.52	142	Vertical	PK	Pass
4	8163.0000	-64.46	8.66	-73.12	-13	-51.46	92.6	Vertical	PK	Pass
5	11119.5000	-60.34	15.84	-76.18	-13	-47.34	163.1	Vertical	PK	Pass
6	14083.5000	-56.63	19.04	-75.67	-13	-43.63	34	Vertical	PK	Pass



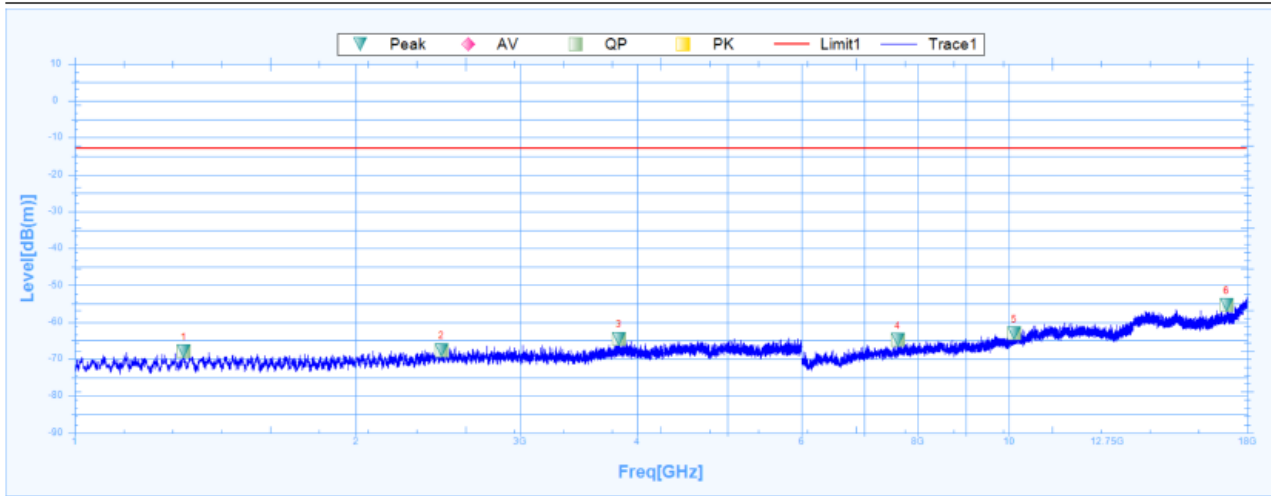

Suspected Data List

NO.	Freq. [MHz]	Level [dB(m)]	Factor [dB]	Reading [dB(m)]	Limit [dB]	Margin [dB]	Deg [°]	Polarity	Trace	Verdict
1	1308.1250	-67.89	24.78	-92.67	-13	-54.89	202.9	Horizontal	PK	Pass
2	2470.0000	-67.58	27.5	-95.08	-13	-54.58	8.8	Horizontal	PK	Pass
3	3826.2500	-64.48	29.28	-93.76	-13	-51.48	76.2	Horizontal	PK	Pass
4	7603.5000	-64.73	7.94	-72.67	-13	-51.73	234.8	Horizontal	PK	Pass
5	10137.0000	-63.13	12.77	-75.9	-13	-50.13	345.9	Horizontal	PK	Pass
6	17101.5000	-55.35	19.99	-75.34	-13	-42.35	173.8	Horizontal	PK	Pass



Vertical:

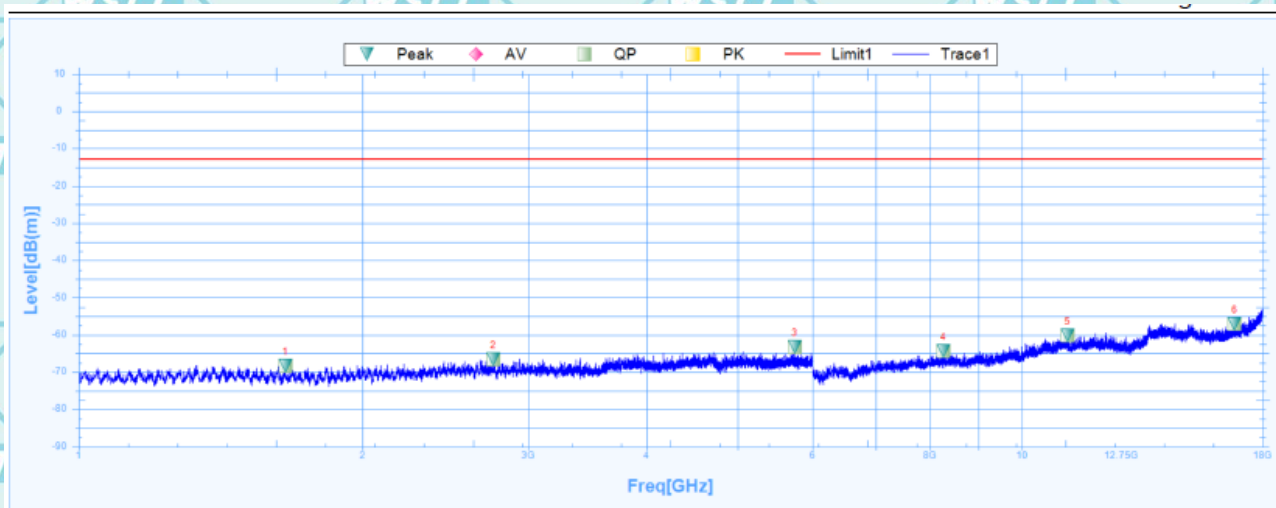

Suspected Data List

NO.	Freq. [MHz]	Level [dB(m)]	Factor [dB]	Reading [dB(m)]	Limit [dB]	Margin [dB]	Deg [°]	Polarity	Trace	Verdict
1	1656.2500	-68.39	24.93	-93.32	-13	-55.39	-0.1	Vertical	PK	Pass
2	2753.7500	-66.62	27.9	-94.52	-13	-53.62	218.4	Vertical	PK	Pass
3	5746.8750	-63.17	32.39	-95.56	-13	-50.17	357.9	Vertical	PK	Pass
4	8260.5000	-64.31	8.88	-73.19	-13	-51.31	65	Vertical	PK	Pass
5	11182.5000	-60.17	15.77	-75.94	-13	-47.17	172.7	Vertical	PK	Pass
6	16813.5000	-57.03	19.77	-76.8	-13	-44.03	355.9	Vertical	PK	Pass



Band 38:
Horizontal:

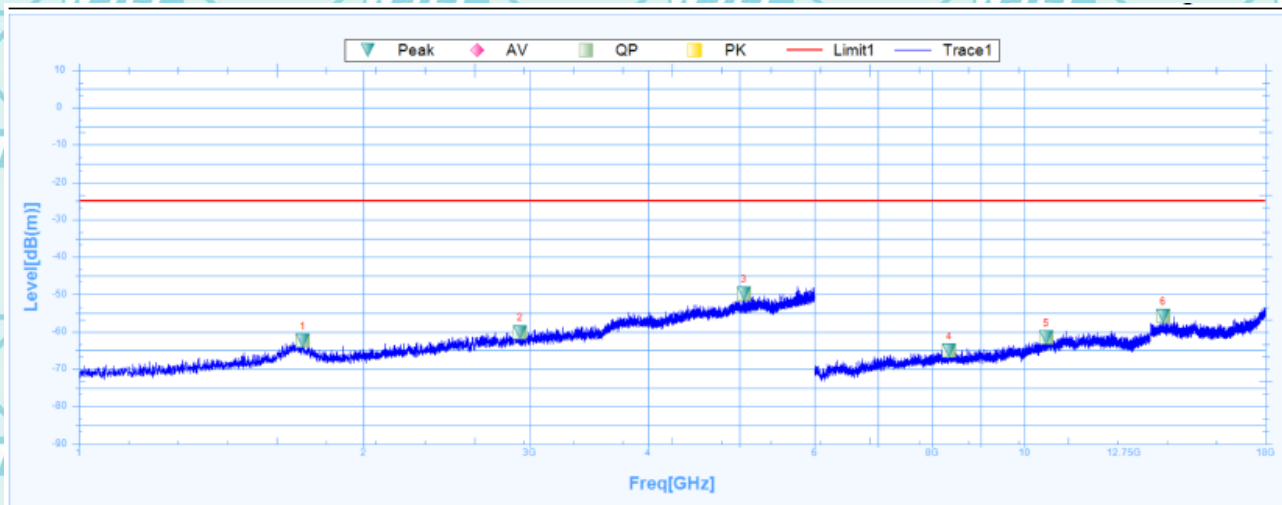

Susputed Data List

NO.	Freq. [MHz]	Level [dB(m)]	Factor [dB]	Reading [dB(m)]	Limit [dB]	Margin [dB]	Deg [°]	Polarity	Trace	Verdict
1	1725.0000	-62.29	24.96	-87.25	-25	-37.29	46.3	Horizontal	PK	Pass
2	2931.2500	-60.07	28.12	-88.19	-25	-35.07	249.5	Horizontal	PK	Pass
3	5053.7500	-49.75	31.64	-81.39	-25	-24.75	108.5	Horizontal	PK	Pass
4	8331.0000	-65.08	8.98	-74.06	-25	-40.08	159.6	Horizontal	PK	Pass
5	10557.0000	-61.54	14.16	-75.7	-25	-36.54	150	Horizontal	PK	Pass
6	14019.0000	-55.68	19.11	-74.79	-25	-30.68	313.8	Horizontal	PK	Pass



Vertical:

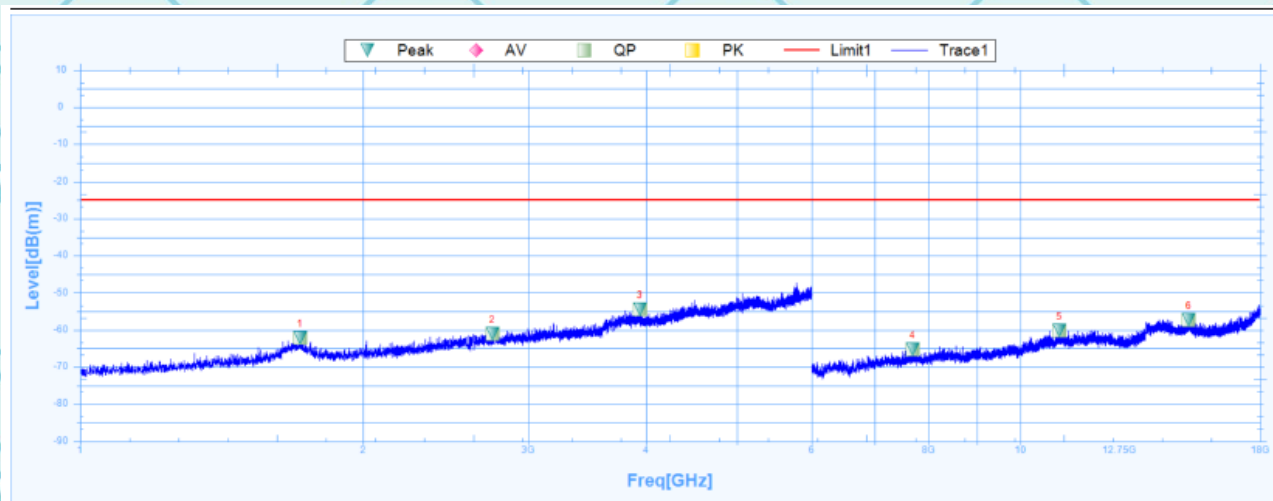

Suspected Data List										
NO.	Freq. [MHz]	Level [dB(m)]	Factor [dB]	Reading [dB(m)]	Limit [dB]	Margin [dB]	Deg [°]	Polarity	Trace	Verdict
1	1713.1250	-62.19	24.96	-87.15	-25	-37.19	127.6	Vertical	PK	Pass
2	2745.0000	-61.11	27.89	-89	-25	-36.11	119.3	Vertical	PK	Pass
3	3941.2500	-54.44	29.56	-84	-25	-29.44	283	Vertical	PK	Pass
4	7683.0000	-65.17	7.95	-73.12	-25	-40.17	0	Vertical	PK	Pass
5	11011.5000	-60.22	15.65	-75.87	-25	-35.22	337.8	Vertical	PK	Pass
6	15109.5000	-57.22	19.68	-76.9	-25	-32.22	29.6	Vertical	PK	Pass



Band 41:
Horizontal:

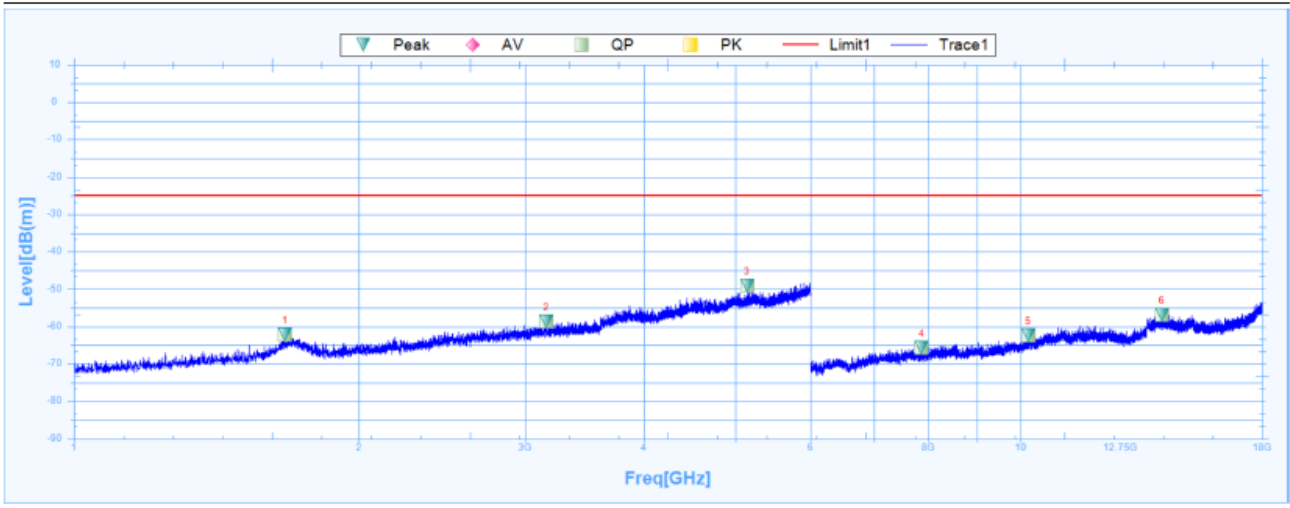

Suspected Data List										
NO.	Freq. [MHz]	Level [dB(m)]	Factor [dB]	Reading [dB(m)]	Limit [dB]	Margin [dB]	Deg [°]	Polarity	Trace	Verdict
1	1671.2500	-62.15	24.94	-87.09	-25	-37.15	213.2	Horizontal	PK	Pass
2	3155.6250	-58.65	28.29	-86.94	-25	-33.65	246.7	Horizontal	PK	Pass
3	5142.5000	-49.2	31.71	-80.91	-25	-24.2	173.8	Horizontal	PK	Pass
4	7864.5000	-65.71	8.01	-73.72	-25	-40.71	225.7	Horizontal	PK	Pass
5	10194.0000	-62.47	12.96	-75.43	-25	-37.47	38	Horizontal	PK	Pass
6	14104.5000	-56.87	19.02	-75.89	-25	-31.87	4.2	Horizontal	PK	Pass



Vertical:

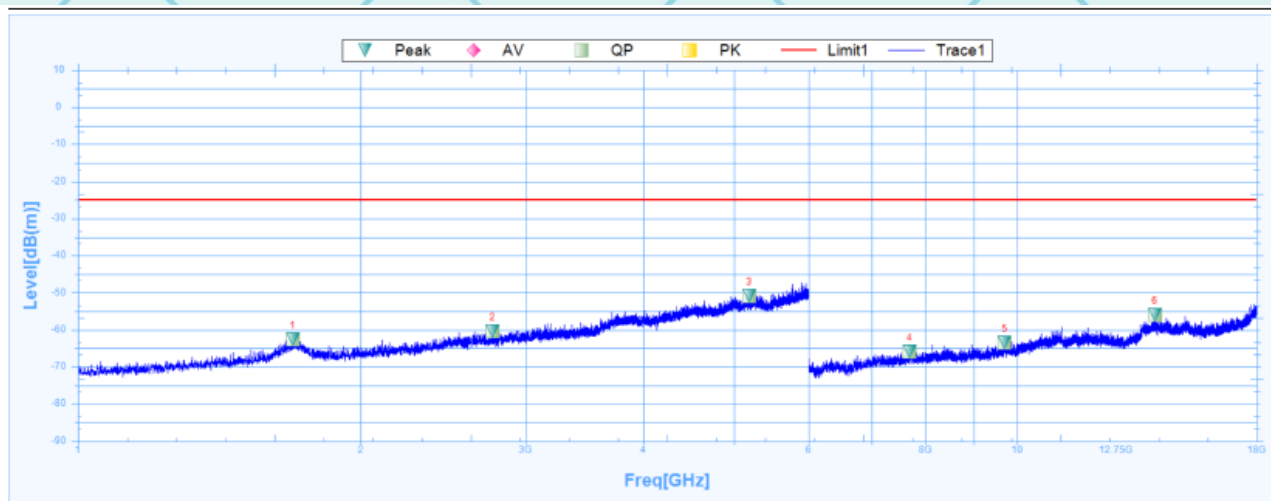

Suspected Data List										
NO.	Freq. [MHz]	Level [dB(m)]	Factor [dB]	Reading [dB(m)]	Limit [dB]	Margin [dB]	Deg [°]	Polarity	Trace	Verdict
1	1693.1250	-62.54	24.95	-87.49	-25	-37.54	321	Vertical	PK	Pass
2	2765.0000	-60.44	27.92	-88.36	-25	-35.44	8	Vertical	PK	Pass
3	5188.7500	-50.87	31.75	-82.62	-25	-25.87	48.4	Vertical	PK	Pass
4	7689.0000	-65.95	7.96	-73.91	-25	-40.95	359.4	Vertical	PK	Pass
5	9708.0000	-63.44	11.65	-75.09	-25	-38.44	158.7	Vertical	PK	Pass
6	14019.0000	-55.99	19.11	-75.1	-25	-30.99	0	Vertical	PK	Pass



Report No.: WSCT-ANAB-R&E250800067A-RF Issued: 02 September 2025
Band 42(3450-3550Mhz):
Horizontal:

Revised: None

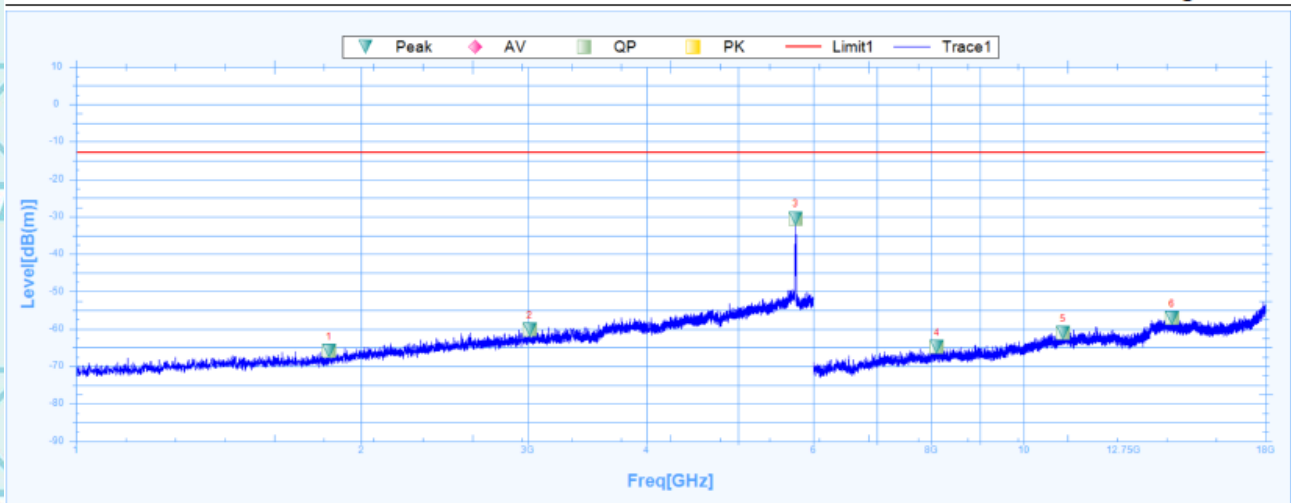

Suspected Data List

NO.	Freq. [MHz]	Level [dB(m)]	Factor [dB]	Reading [dB(m)]	Limit [dB]	Margin [dB]	Deg [°]	Polarity	Trace	Verdict
1	1849.3750	-65.99	25.22	-91.21	-13	-52.99	0.9	Horizontal	PK	Pass
2	3011.8750	-60.27	28.21	-88.48	-13	-47.27	77	Horizontal	PK	Pass
3	5749.3750	-30.47	32.4	-62.87	-13	-17.47	288.6	Horizontal	PK	Pass
4	8104.5000	-64.84	8.5	-73.34	-13	-51.84	-0.1	Horizontal	PK	Pass
5	11005.5000	-61.06	15.64	-76.7	-13	-48.06	323.6	Horizontal	PK	Pass
6	14338.5000	-57.16	18.78	-75.94	-13	-44.16	18.8	Horizontal	PK	Pass



Vertical:

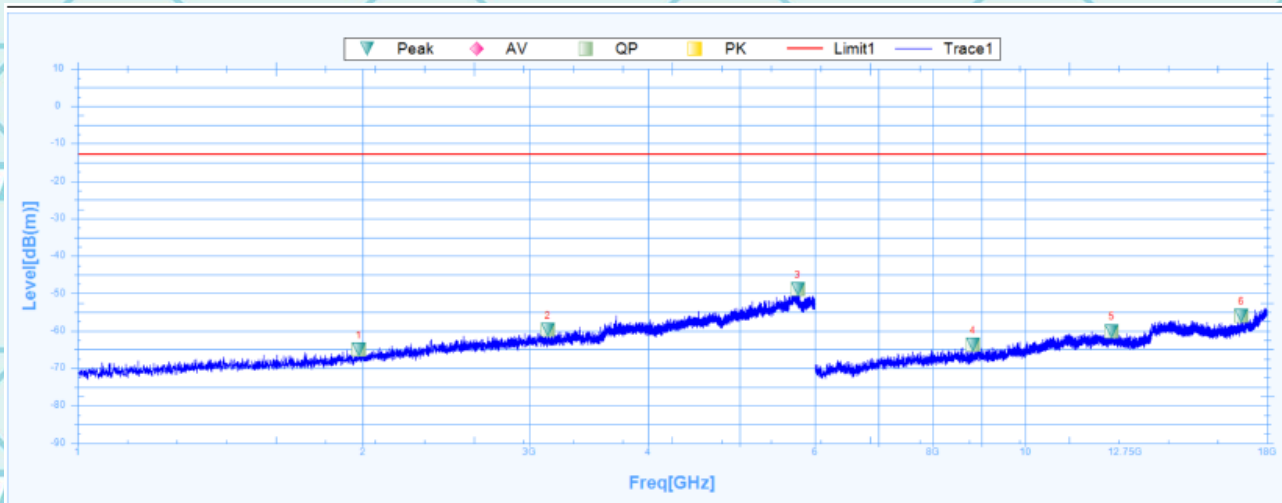

Susputed Data List

NO.	Freq. [MHz]	Level [dB(m)]	Factor [dB]	Reading [dB(m)]	Limit [dB]	Margin [dB]	Deg [°]	Polarity	Trace	Verdict
1	1980.6250	-65	25.81	-90.81	-13	-52	50.6	Vertical	PK	Pass
2	3136.2500	-59.76	28.28	-88.04	-13	-46.76	293.2	Vertical	PK	Pass
3	5755.6250	-48.88	32.41	-81.29	-13	-35.88	331.4	Vertical	PK	Pass
4	8808.0000	-63.78	9.51	-73.29	-13	-50.78	40.3	Vertical	PK	Pass
5	12348.0000	-60.06	16.47	-76.53	-13	-47.06	296.1	Vertical	PK	Pass
6	16914.0000	-56.03	20.07	-76.1	-13	-43.03	350.7	Vertical	PK	Pass



Band 66:
Horizontal:

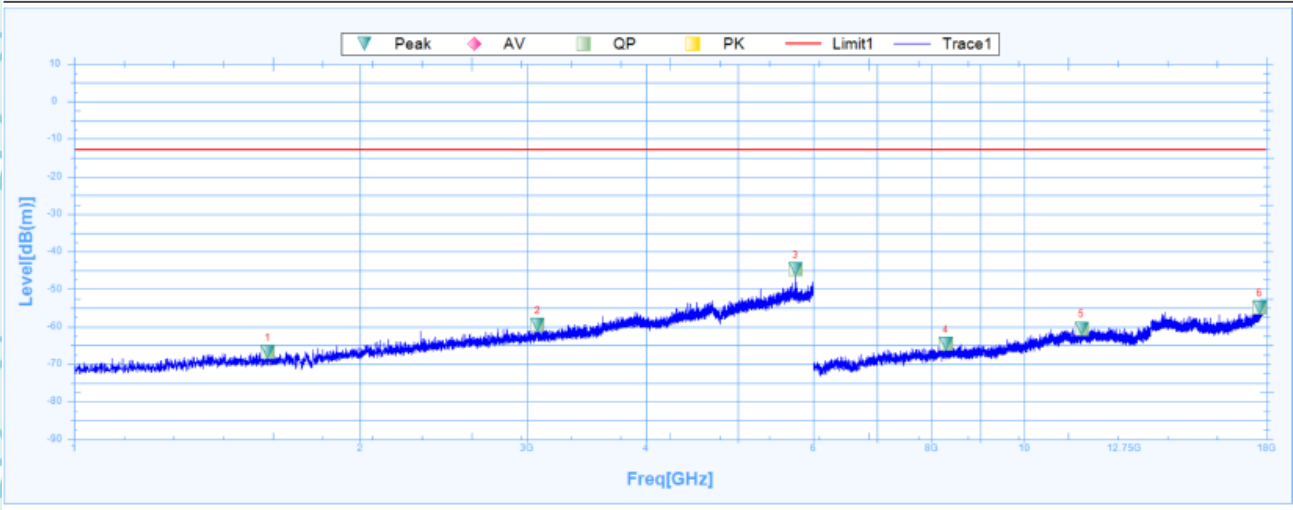

Suspected Data List										
NO.	Freq. [MHz]	Level [dB(m)]	Factor [dB]	Reading [dB(m)]	Limit [dB]	Margin [dB]	Deg [°]	Polarity	Trace	Verdict
1	1598.7500	-66.89	24.9	-91.79	-13	-53.89	47.1	Horizontal	PK	Pass
2	3076.2500	-59.5	28.25	-87.75	-13	-46.5	95	Horizontal	PK	Pass
3	5748.1250	-44.64	32.4	-77.04	-13	-31.64	146.3	Horizontal	PK	Pass
4	8272.5000	-64.55	8.9	-73.45	-13	-51.55	115.6	Horizontal	PK	Pass
5	11493.0000	-60.51	16.11	-76.62	-13	-47.51	212.4	Horizontal	PK	Pass
6	17698.5000	-54.89	21.95	-76.84	-13	-41.89	287.8	Horizontal	PK	Pass



Vertical:

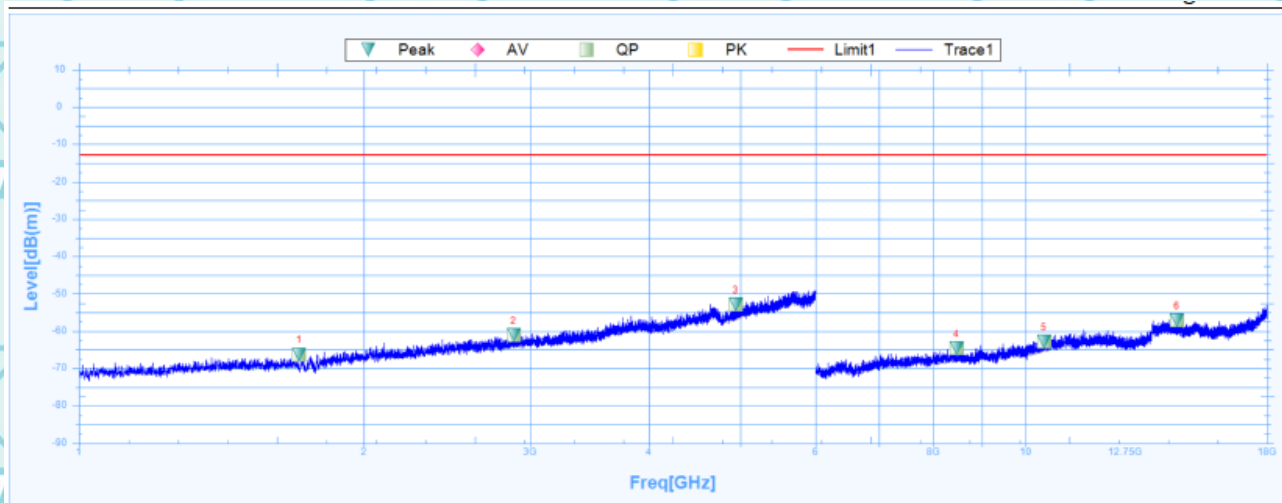

Suspected Data List

NO.	Freq. [MHz]	Level [dB(m)]	Factor [dB]	Reading [dB(m)]	Limit [dB]	Margin [dB]	Deg [°]	Polarity	Trace	Verdict
1	1708.7500	-66.25	24.95	-91.2	-13	-53.25	65	Vertical	PK	Pass
2	2880.0000	-60.97	28.06	-89.03	-13	-47.97	360.1	Vertical	PK	Pass
3	4943.1250	-52.81	31.49	-84.3	-13	-39.81	105.8	Vertical	PK	Pass
4	8458.5000	-64.64	9.16	-73.8	-13	-51.64	358.2	Vertical	PK	Pass
5	10464.0000	-62.73	13.8	-76.53	-13	-49.73	248	Vertical	PK	Pass
6	14454.0000	-57.06	18.67	-75.73	-13	-44.06	360.1	Vertical	PK	Pass



NR Bands
n5:
Horizontal:

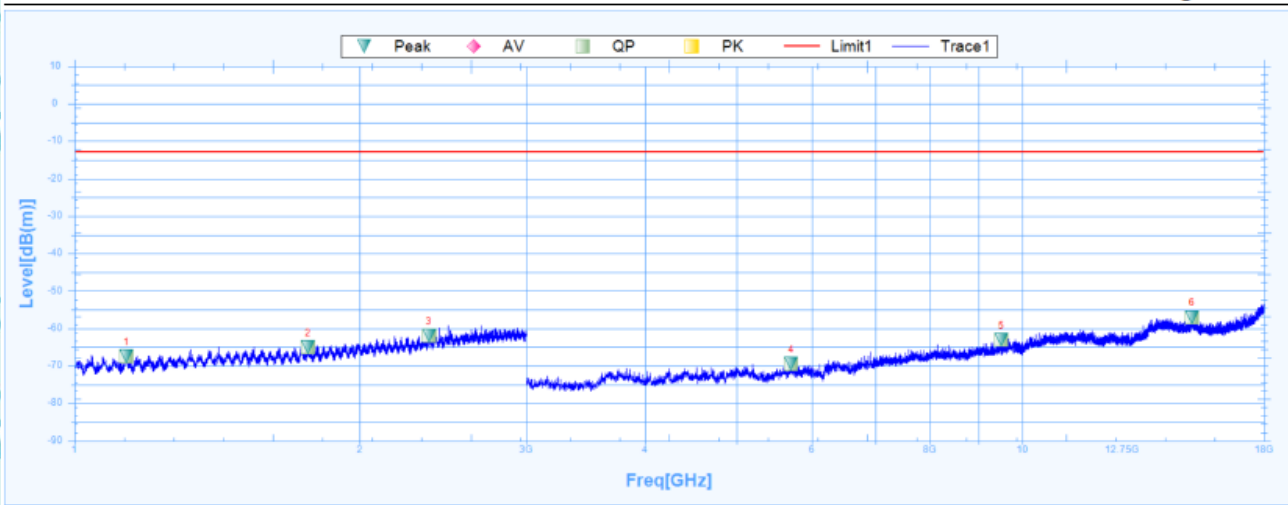

Suspected Data List

NO.	Freq. [MHz]	Level [dB(m)]	Factor [dB]	Reading [dB(m)]	Limit [dB]	Margin [dB]	Deg [°]	Polarity	Trace	Verdict
1	1134.5000	-67.41	24.37	-91.78	-13	-54.41	351.8	Horizontal	PK	Pass
1	1134.5000		24.37		54		351.8	Horizontal	AV	Pass
2	1764.7500	-64.96	24.98	-89.94	-13	-51.96	18.9	Horizontal	PK	Pass
2	1764.7500		24.98		54		18.9	Horizontal	AV	Pass
3	2367.2500	-61.92	27.15	-89.07	-13	-48.92	0	Horizontal	PK	Pass
3	2367.2500		27.15		54		0	Horizontal	AV	Pass
4	5705.6250	-69.52	32.33	-101.85	-13	-56.52	206.1	Horizontal	PK	Pass
4	5705.6250		32.33		54		206.1	Horizontal	AV	Pass
5	9510.0000	-63	11.17	-74.17	-13	-50	360	Horizontal	PK	Pass
5	9510.0000		11.17		54		360	Horizontal	AV	Pass
6	15110.6250	-56.98	19.69	-76.67	-13	-43.98	237.2	Horizontal	PK	Pass
6	15110.6250		19.69		54		237.2	Horizontal	AV	Pass



Vertical:

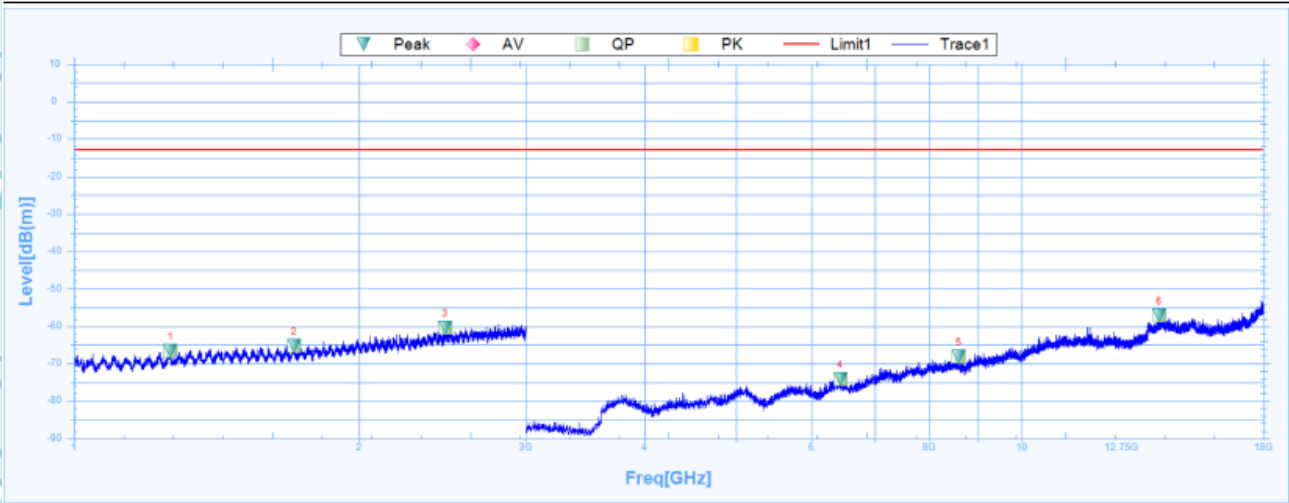

Susputed Data List

NO.	Freq. [MHz]	Level [dB(m)]	Factor [dB]	Reading [dB(m)]	Limit [dB]	Margin [dB]	Deg [°]	Polarity	Trace	Verdict
1	1264.7500	-66.5	24.63	-91.13	-13	-53.5	263.8	Vertical	PK	Pass
1	1264.7500		24.63		54		263.8	Vertical	AV	Pass
2	1708.0000	-65.18	24.95	-90.13	-13	-52.18	28.4	Vertical	PK	Pass
2	1708.0000		24.95		54		28.4	Vertical	AV	Pass
3	2464.2500	-60.46	27.48	-87.94	-13	-47.46	359.1	Vertical	PK	Pass
3	2464.2500		27.48		54		359.1	Vertical	AV	Pass
4	6436.8750	-74	4.61	-78.61	-13	-61	269.5	Vertical	PK	Pass
4	6436.8750		4.61		54		269.5	Vertical	AV	Pass
5	8589.3750	-68.2	9.32	-77.52	-13	-55.2	0.5	Vertical	PK	Pass
5	8589.3750		9.32		54		0.5	Vertical	AV	Pass
6	13974.3750	-57.06	19.04	-76.1	-13	-44.06	93.8	Vertical	PK	Pass
6	13974.3750		19.04		54		93.8	Vertical	AV	Pass



n7:
Horizontal:



Susputed Data List

NO.	Freq. [MHz]	Level [dB(m)]	Factor [dB]	Reading [dB(m)]	Limit [dB]	Margin [dB]	Deg [°]	Polarity	Trace	Verdict
1	1898.7500	-64.67	2.49	-67.16	-25	-39.67	359.5	Horizontal	PK	Pass
2	3145.0000	-58.63	9.69	-68.32	-25	-33.63	334.3	Horizontal	PK	Pass
3	5020.6250	-50.01	18.15	-68.16	-25	-25.01	286.6	Horizontal	PK	Pass
4	8191.5000	-64.89	37.08	-101.97	-25	-39.89	267	Horizontal	PK	Pass
5	11127.0000	-61.09	39.39	-100.48	-25	-36.09	352	Horizontal	PK	Pass
6	14178.0000	-56.91	41.27	-98.18	-25	-31.91	1.2	Horizontal	PK	Pass



Vertical:

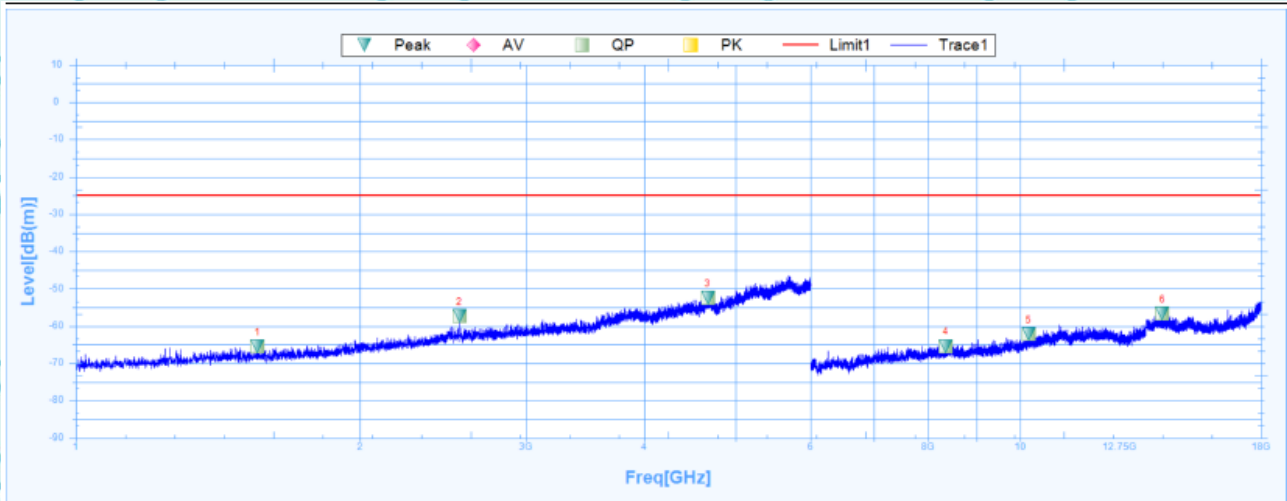

Suspected Data List

NO.	Freq. [MHz]	Level [dB(m)]	Factor [dB]	Reading [dB(m)]	Limit [dB]	Margin [dB]	Deg [°]	Polarity	Trace	Verdict
1	1557.5000	-65.51	24.94	-90.45	-25	-40.51	114.5	Vertical	PK	Pass
2	2548.7500	-57.39	27.66	-85.05	-25	-32.39	47.5	Vertical	PK	Pass
3	4670.0000	-52.5	30.94	-83.44	-25	-27.5	0	Vertical	PK	Pass
4	8349.0000	-65.37	9.01	-74.38	-25	-40.37	348.1	Vertical	PK	Pass
5	10216.5000	-62.25	13.03	-75.28	-25	-37.25	148.6	Vertical	PK	Pass
6	14155.5000	-56.57	18.97	-75.54	-25	-31.57	360	Vertical	PK	Pass



n12:
Horizontal:



Susputed Data List

NO.	Freq. [MHz]	Level [dB(m)]	Factor [dB]	Reading [dB(m)]	Limit [dB]	Margin [dB]	Deg [°]	Polarity	Trace	Verdict
1	1888.1250	-65.83	25.4	-91.23	-13	-52.83	336.7	Horizontal	PK	Pass
1	1888.1250		25.4		54		336.7	Horizontal	AV	Pass
2	2815.0000	-60.26	27.98	-88.24	-13	-47.26	167.1	Horizontal	PK	Pass
2	2815.0000		27.98		54		167.1	Horizontal	AV	Pass
3	4699.3750	-53.58	31	-84.58	-13	-40.58	248.4	Horizontal	PK	Pass
3	4699.3750		31		54		248.4	Horizontal	AV	Pass
4	6805.5000	-67.41	5.63	-73.04	-13	-54.41	207.4	Horizontal	PK	Pass
4	6805.5000		5.63		54		207.4	Horizontal	AV	Pass
5	9669.0000	-63.23	11.55	-74.78	-13	-50.23	311.4	Horizontal	PK	Pass
5	9669.0000		11.55		54		311.4	Horizontal	AV	Pass
6	14307.0000	-56.77	18.81	-75.58	-13	-43.77	93.8	Horizontal	PK	Pass
6	14307.0000		18.81		54		93.8	Horizontal	AV	Pass



Vertical:

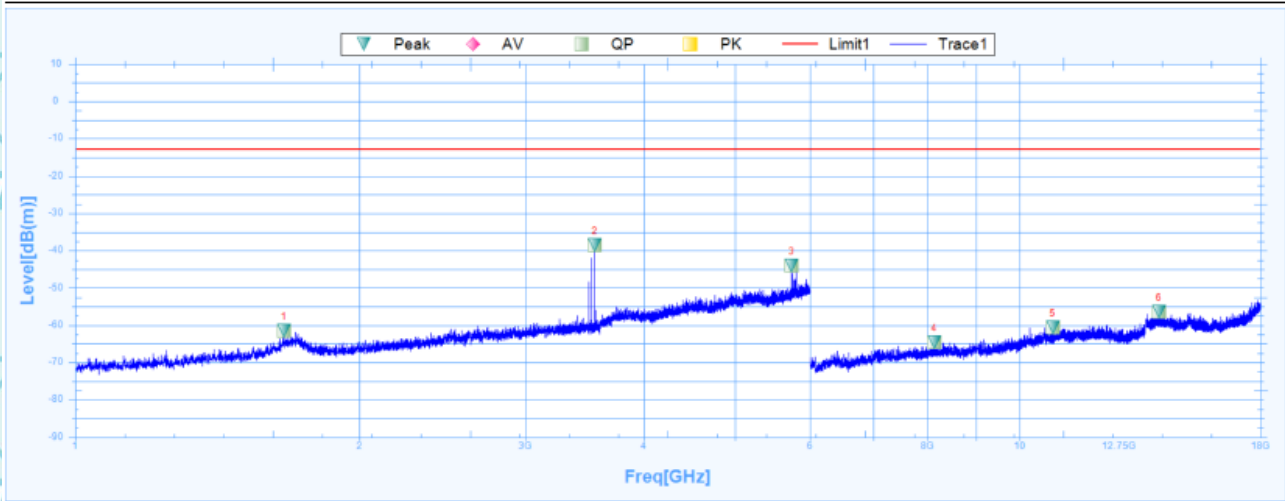

Susputed Data List

NO.	Freq. [MHz]	Level [dB(m)]	Factor [dB]	Reading [dB(m)]	Limit [dB]	Margin [dB]	Deg [°]	Polarity	Trace	Verdict
1	1662.5000	-61.41	24.93	-86.34	-13	-48.41	11	Vertical	PK	Pass
1	1662.5000		24.93		54		11	Vertical	AV	Pass
2	3551.8750	-38.48	28.62	-67.1	-13	-25.48	20.2	Vertical	PK	Pass
2	3551.8750		28.62		54		20.2	Vertical	AV	Pass
3	5738.7500	-44.11	32.38	-76.49	-13	-31.11	0.1	Vertical	PK	Pass
3	5738.7500		32.38		54		0.1	Vertical	AV	Pass
4	8124.0000	-64.55	8.55	-73.1	-13	-51.55	71	Vertical	PK	Pass
4	8124.0000		8.55		54		71	Vertical	AV	Pass
5	10842.0000	-60.53	14.84	-75.37	-13	-47.53	96.2	Vertical	PK	Pass
5	10842.0000		14.84		54		96.2	Vertical	AV	Pass
6	14049.0000	-56.5	19.08	-75.58	-13	-43.5	11.4	Vertical	PK	Pass
6	14049.0000		19.08		54		11.4	Vertical	AV	Pass



n38:
Horizontal:

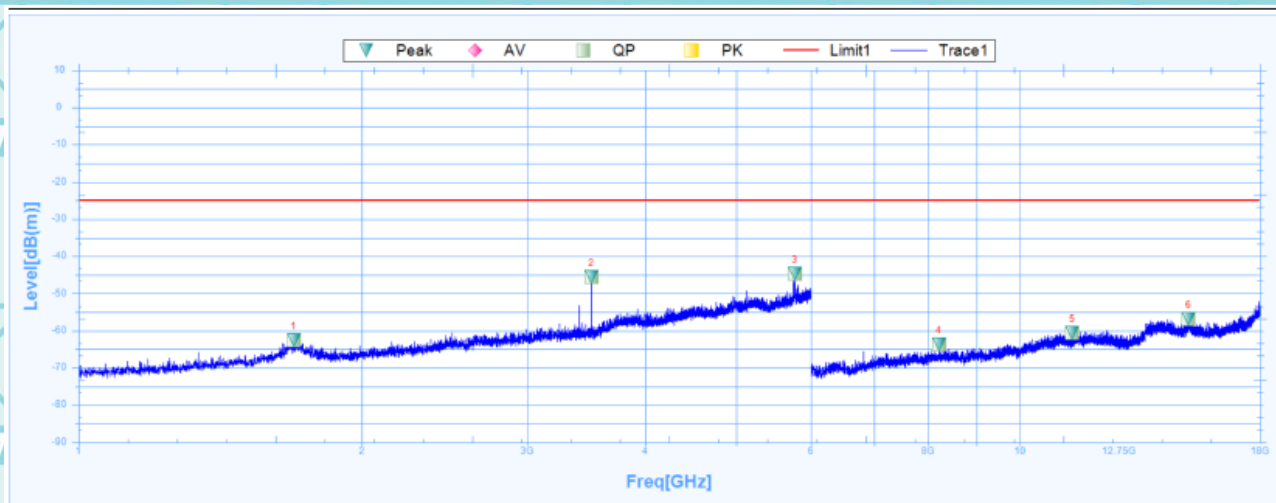

Suspected Data List

NO.	Freq. [MHz]	Level [dB(m)]	Factor [dB]	Reading [dB(m)]	Limit [dB]	Margin [dB]	Deg [°]	Polarity	Trace	Verdict
1	1692.5000	-62.67	24.95	-87.62	-25	-37.67	3.4	Horizontal	PK	Pass
2	3508.7500	-45.53	28.52	-74.05	-25	-20.53	39.1	Horizontal	PK	Pass
3	5766.8750	-44.71	32.43	-77.14	-25	-19.71	295	Horizontal	PK	Pass
4	8208.0000	-63.77	8.77	-72.54	-25	-38.77	360.1	Horizontal	PK	Pass
5	11374.5000	-60.58	15.78	-76.36	-25	-35.58	197.8	Horizontal	PK	Pass
6	15114.0000	-56.94	19.72	-76.66	-25	-31.94	12.1	Horizontal	PK	Pass



Vertical:

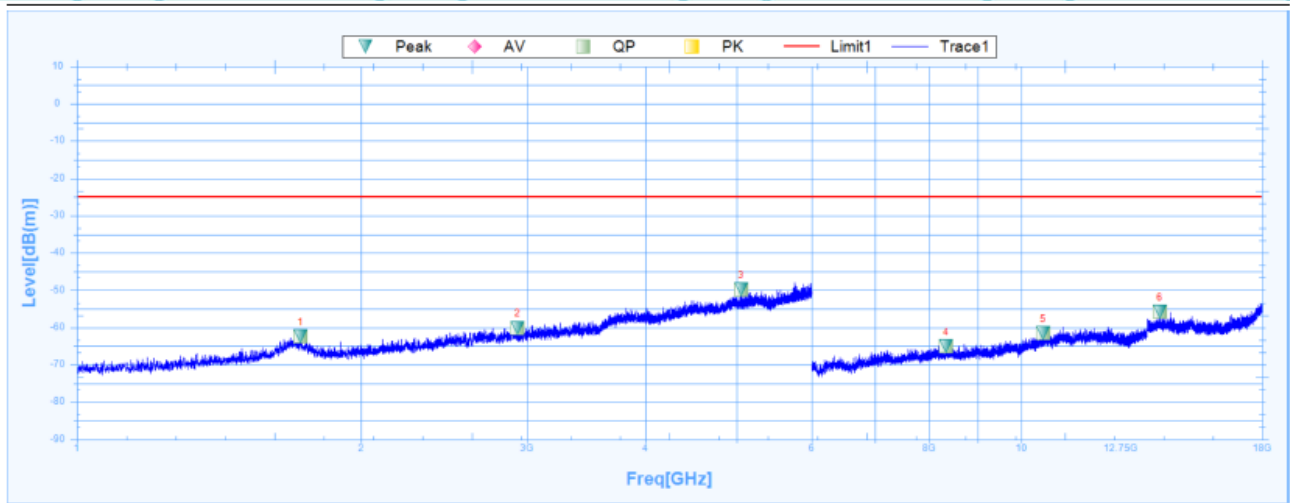

Susputed Data List

NO.	Freq. [MHz]	Level [dB(m)]	Factor [dB]	Reading [dB(m)]	Limit [dB]	Margin [dB]	Deg [°]	Polarity	Trace	Verdict
1	1725.0000	-62.29	24.96	-87.25	-25	-37.29	46.3	Horizontal	PK	Pass
2	2931.2500	-60.07	28.12	-88.19	-25	-35.07	249.5	Horizontal	PK	Pass
3	5053.7500	-49.75	31.64	-81.39	-25	-24.75	108.5	Horizontal	PK	Pass
4	8331.0000	-65.08	8.98	-74.06	-25	-40.08	159.6	Horizontal	PK	Pass
5	10557.0000	-61.54	14.16	-75.7	-25	-36.54	150	Horizontal	PK	Pass
6	14019.0000	-55.68	19.11	-74.79	-25	-30.68	313.8	Horizontal	PK	Pass



n41:
Horizontal:

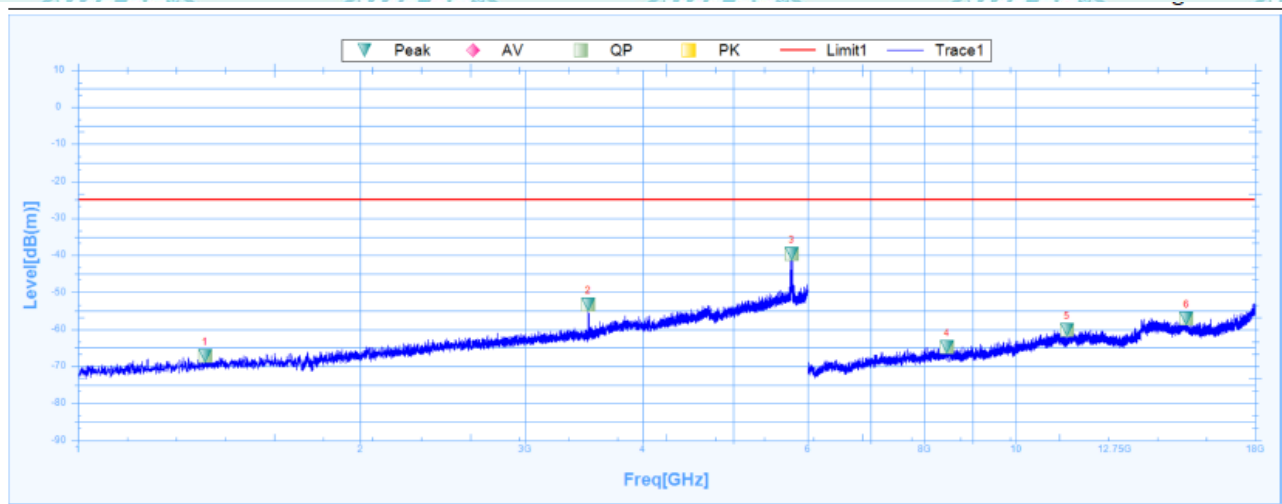

Suspected Data List

NO.	Freq. [MHz]	Level [dB(m)]	Factor [dB]	Reading [dB(m)]	Limit [dB]	Margin [dB]	Deg [°]	Polarity	Trace	Verdict
1	1365.6250	-67.21	-0.54	-66.67	-25	-42.21	299.7	Horizontal	PK	Pass
2	3501.8750	-53.36	9.97	-63.33	-25	-28.36	242.3	Horizontal	PK	Pass
3	5770.0000	-39.54	21.54	-61.08	-25	-14.54	256.6	Horizontal	PK	Pass
4	8449.5000	-64.79	37.18	-101.97	-25	-39.79	139.2	Horizontal	PK	Pass
5	11341.5000	-60.1	39.19	-99.29	-25	-35.1	353.8	Horizontal	PK	Pass
6	15210.0000	-57.08	39.55	-96.63	-25	-32.08	170.3	Horizontal	PK	Pass



Vertical:

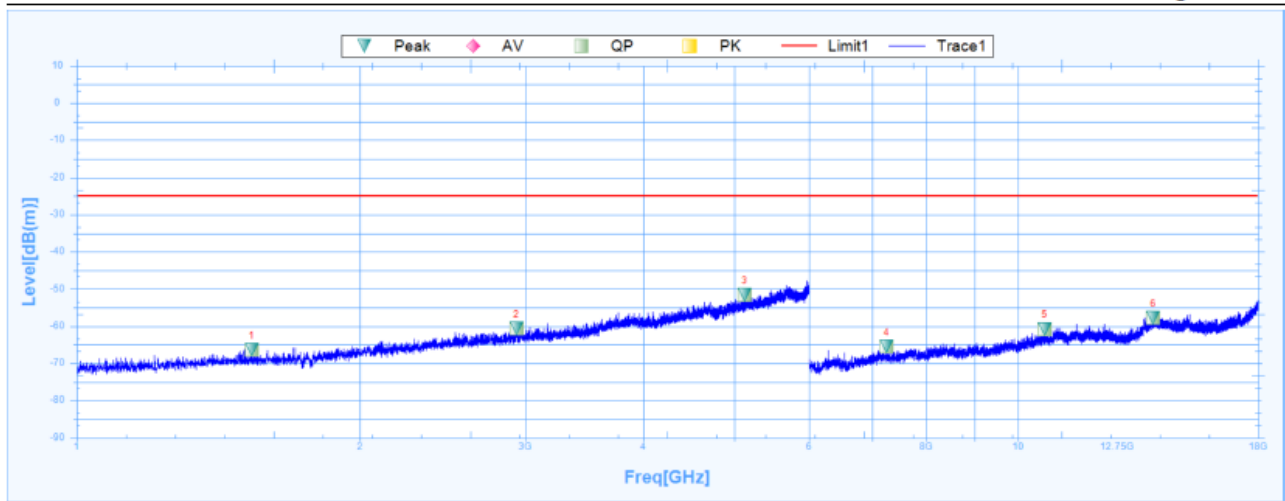

Suspected Data List

NO.	Freq. [MHz]	Level [dB(m)]	Factor [dB]	Reading [dB(m)]	Limit [dB]	Margin [dB]	Deg [°]	Polarity	Trace	Verdict
1	1534.3750	-66.4	0.06	-66.46	-25	-41.4	155.1	Vertical	PK	Pass
2	2933.7500	-60.65	7.73	-68.38	-25	-35.65	121.7	Vertical	PK	Pass
3	5128.1250	-51.64	18.01	-69.65	-25	-26.64	69	Vertical	PK	Pass
4	7255.5000	-65.5	35.88	-101.38	-25	-40.5	236	Vertical	PK	Pass
5	10677.0000	-60.73	39.05	-99.78	-25	-35.73	175	Vertical	PK	Pass
6	13927.5000	-57.69	41.31	-99	-25	-32.69	323.2	Vertical	PK	Pass



n66:
Horizontal:

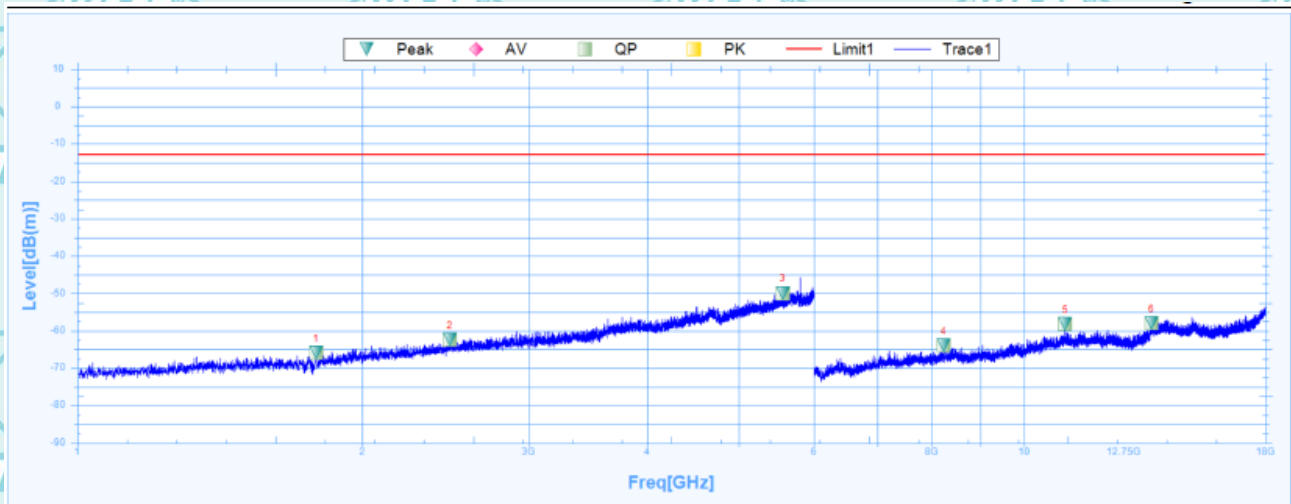

Susputed Data List

NO.	Freq. [MHz]	Level [dB(m)]	Factor [dB]	Reading [dB(m)]	Limit [dB]	Margin [dB]	Deg [°]	Polarity	Trace	Verdict
1	1786.8750	-65.86	24.99	-90.85	-13	-52.86	171.4	Horizontal	PK	Pass
1	1786.8750		24.99		54		171.4	Horizontal	AV	Pass
2	2475.0000	-62.39	27.52	-89.91	-13	-49.39	13.7	Horizontal	PK	Pass
2	2475.0000		27.52		54		13.7	Horizontal	AV	Pass
3	5565.6250	-49.9	32.1	-82	-13	-36.9	360	Horizontal	PK	Pass
3	5565.6250		32.1		54		360	Horizontal	AV	Pass
4	8227.5000	-63.97	8.82	-72.79	-13	-50.97	-0.1	Horizontal	PK	Pass
4	8227.5000		8.82		54		-0.1	Horizontal	AV	Pass
5	11061.0000	-58.21	15.82	-74.03	-13	-45.21	-0.1	Horizontal	PK	Pass
5	11061.0000		15.82		54		-0.1	Horizontal	AV	Pass
6	13636.5000	-57.95	18.07	-76.02	-13	-44.95	189.8	Horizontal	PK	Pass
6	13636.5000		18.07		54		189.8	Horizontal	AV	Pass



Vertical:

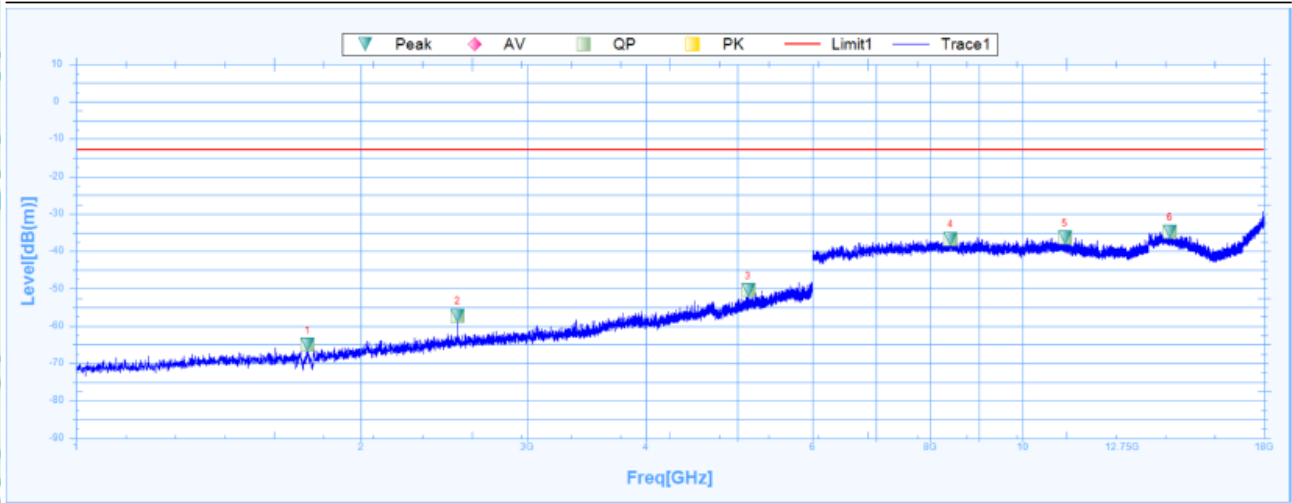

Susputed Data List

NO.	Freq. [MHz]	Level [dB(m)]	Factor [dB]	Reading [dB(m)]	Limit [dB]	Margin [dB]	Deg [°]	Polarity	Trace	Verdict
1	1756.8750	-65.11	24.98	-90.09	-13	-52.11	73.4	Vertical	PK	Pass
1	1756.8750		24.98		54		73.4	Vertical	AV	Pass
2	2530.6250	-57.19	27.64	-84.83	-13	-44.19	1	Vertical	PK	Pass
2	2530.6250		27.64		54		1	Vertical	AV	Pass
3	5131.2500	-50.51	31.7	-82.21	-13	-37.51	360.1	Vertical	PK	Pass
3	5131.2500		31.7		54		360.1	Vertical	AV	Pass
4	8397.0000	-36.64	9.09	-45.73	-13	-23.64	324.8	Vertical	PK	Pass
4	8397.0000		9.09		54		324.8	Vertical	AV	Pass
5	11085.0000	-36.24	15.89	-52.13	-13	-23.24	0.2	Vertical	PK	Pass
5	11085.0000		15.89		54		0.2	Vertical	AV	Pass
6	14314.5000	-34.7	18.8	-53.5	-13	-21.7	170.6	Vertical	PK	Pass
6	14314.5000		18.8		54		170.6	Vertical	AV	Pass



n77(3450-3550Mhz):
Horizontal:

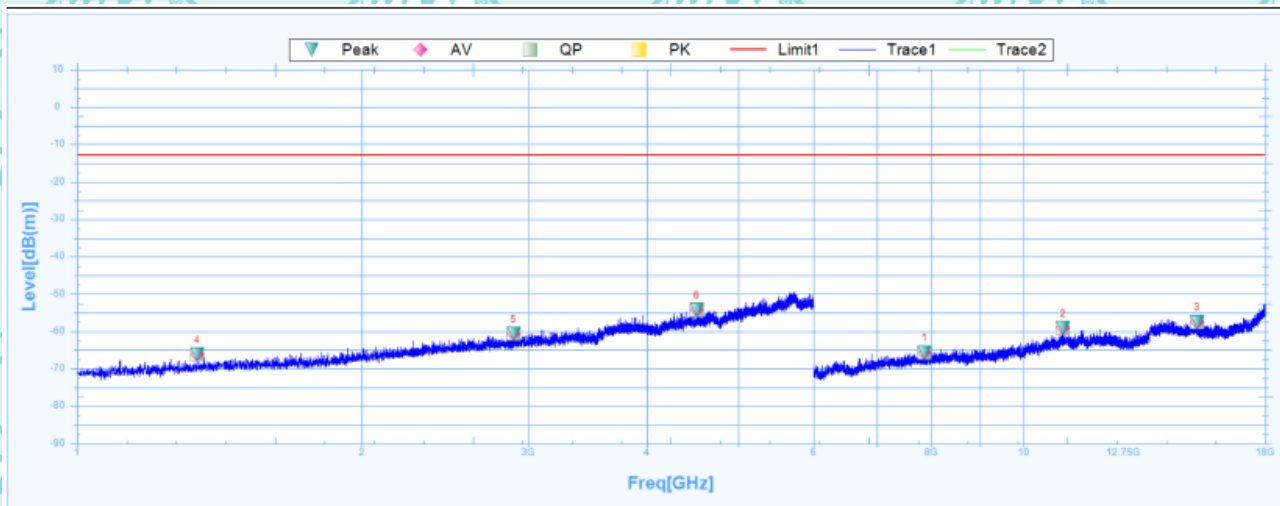

Suspected Data List										
NO.	Freq. [MHz]	Level [dB(m)]	Factor [dB]	Reading [dB(m)]	Limit [dB]	Margin [dB]	Deg [°]	Polarity	Trace	Verdict
1	1340.0000	-66.21	24.89	-91.1	-13	-53.21	246.7	Vertical	PK	Pass
2	2893.1250	-60.67	28.07	-88.74	-13	-47.67	334	Vertical	PK	Pass
3	4516.8750	-54.23	30.63	-84.86	-13	-41.23	28	Vertical	PK	Pass
4	7863.0000	-65.59	8.01	-73.6	-13	-52.59	332.2	Horizontal	PK	Pass
5	11016.0000	-59.04	15.67	-74.71	-13	-46.04	357.4	Horizontal	PK	Pass
6	15267.0000	-57.42	18.63	-76.05	-13	-44.42	236.6	Horizontal	PK	Pass



Vertical:

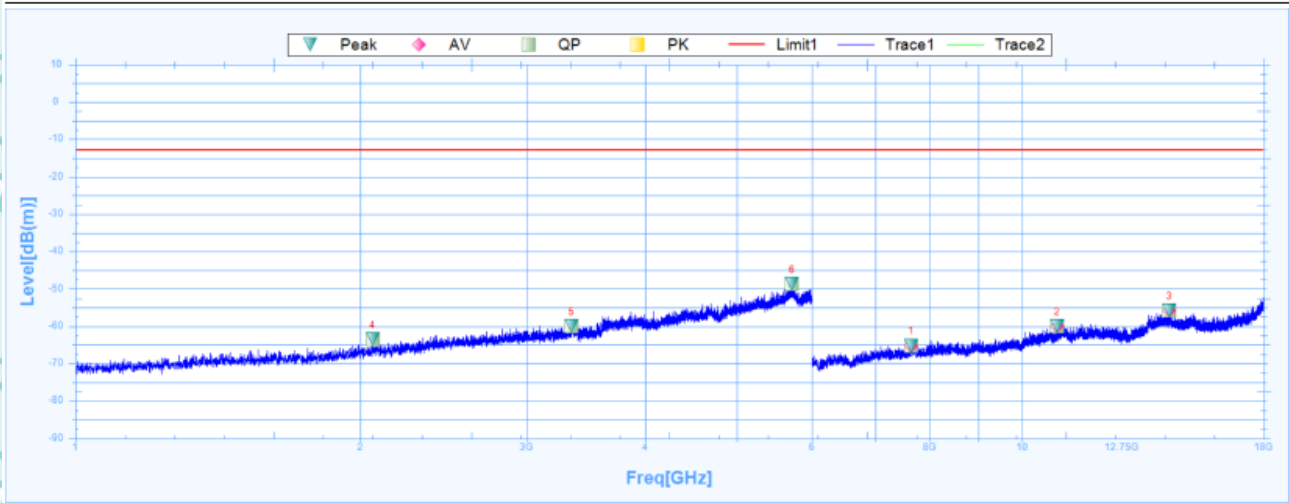

Susputed Data List

NO.	Freq. [MHz]	Level [dB(m)]	Factor [dB]	Reading [dB(m)]	Limit [dB]	Margin [dB]	Deg [°]	Polarity	Trace	Verdict
1	2060.0000	-63.55	26.1	-89.65	-13	-50.55	30.2	Horizontal	PK	Pass
2	3343.1250	-59.87	28.41	-88.28	-13	-46.87	122.2	Horizontal	PK	Pass
3	5715.0000	-48.61	32.34	-80.95	-13	-35.61	337.4	Horizontal	PK	Pass
4	7636.5000	-65.14	7.95	-73.09	-13	-52.14	222.2	Vertical	PK	Pass
5	10900.5000	-60.05	15.06	-75.11	-13	-47.05	359	Vertical	PK	Pass
6	14325.0000	-55.77	18.8	-74.57	-13	-42.77	0.1	Vertical	PK	Pass



n77(3700-3980Mhz):
Horizontal:

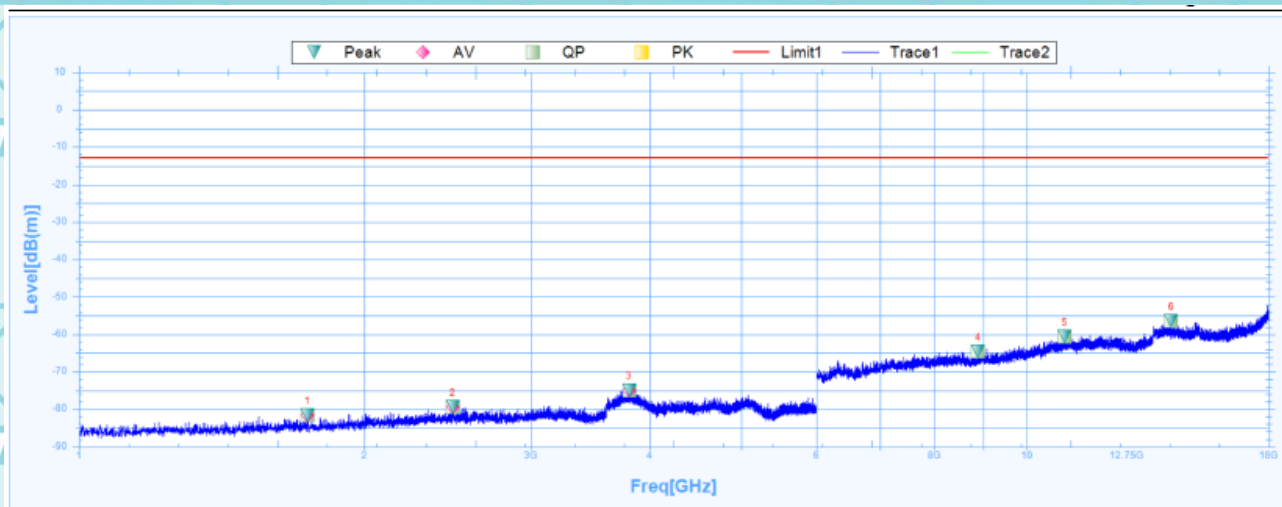

Suspected Data List

NO.	Freq. [MHz]	Level [dB(m)]	Factor [dB]	Reading [dB(m)]	Limit [dB]	Margin [dB]	Deg [°]	Polarity	Trace	Verdict
1	1742.5000	-81.58	24.97	-106.55	-13	-68.58	359.5	Horizontal	PK	Pass
2	2479.3750	-79.45	27.53	-106.98	-13	-66.45	359.5	Horizontal	PK	Pass
3	3805.6250	-75.04	29.23	-104.27	-13	-62.04	146.7	Horizontal	PK	Pass
4	8886.0000	-64.61	9.71	-74.32	-13	-51.61	360.1	Horizontal	PK	Pass
5	10966.5000	-60.54	15.43	-75.97	-13	-47.54	147.6	Horizontal	PK	Pass
6	14212.5000	-56.34	18.91	-75.25	-13	-43.34	0.7	Horizontal	PK	Pass



Vertical:

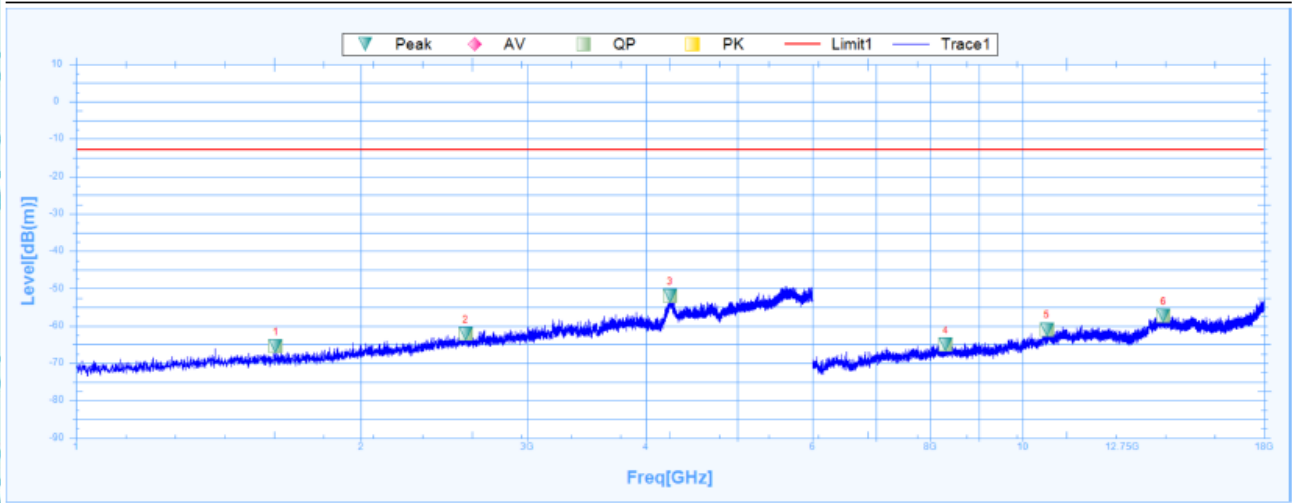

Susputed Data List

NO.	Freq. [MHz]	Level [dB(m)]	Factor [dB]	Reading [dB(m)]	Limit [dB]	Margin [dB]	Deg [°]	Polarity	Trace	Verdict
1	1625.6250	-65.53	24.91	-90.44	-13	-52.53	359.5	Vertical	PK	Pass
2	2580.6250	-62.2	27.7	-89.9	-13	-49.2	359.5	Vertical	PK	Pass
3	4245.6250	-51.91	30.14	-82.05	-13	-38.91	47.7	Vertical	PK	Pass
4	8301.0000	-64.99	8.94	-73.93	-13	-51.99	109.3	Vertical	PK	Pass
5	10609.5000	-60.95	14.35	-75.3	-13	-47.95	170.2	Vertical	PK	Pass
6	14097.0000	-57.39	19.03	-76.42	-13	-44.39	360	Vertical	PK	Pass



n78(3450-3550Mhz):
Horizontal:

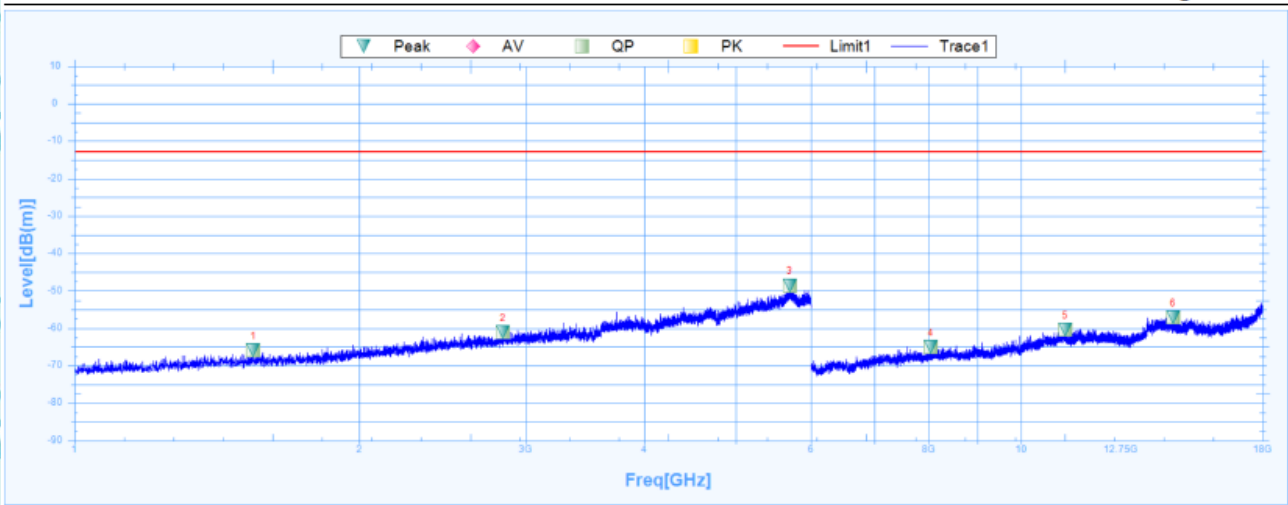

Suspected Data List

NO.	Freq. [MHz]	Level [dB(m)]	Factor [dB]	Reading [dB(m)]	Limit [dB]	Margin [dB]	Deg [°]	Polarity	Trace	Verdict
1	1545.6250	-66	24.95	-90.95	-13	-53	110.9	Horizontal	PK	Pass
2	2838.1250	-61.02	28.01	-89.03	-13	-48.02	0	Horizontal	PK	Pass
3	5698.7500	-48.58	32.32	-80.9	-13	-35.58	358.9	Horizontal	PK	Pass
4	8034.0000	-64.94	8.34	-73.28	-13	-51.94	167.8	Horizontal	PK	Pass
5	11136.0000	-60.4	15.83	-76.23	-13	-47.4	222.7	Horizontal	PK	Pass
6	14478.0000	-57.12	18.65	-75.77	-13	-44.12	142.6	Horizontal	PK	Pass



Vertical:

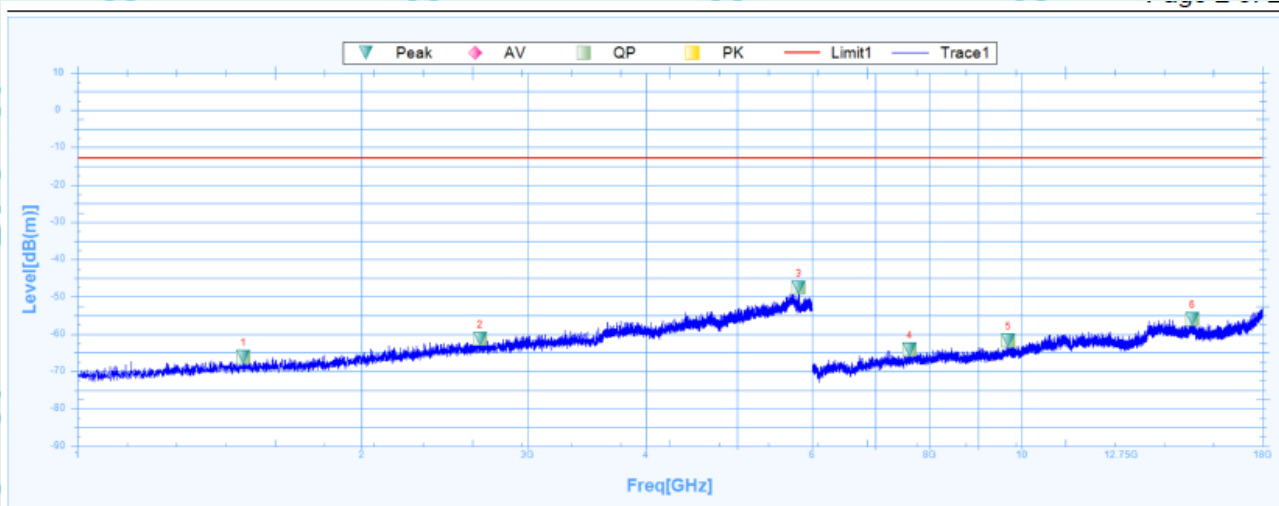

Suspected Data List

NO.	Freq. [MHz]	Level [dB(m)]	Factor [dB]	Reading [dB(m)]	Limit [dB]	Margin [dB]	Deg [°]	Polarity	Trace	Verdict
1	1500.0000	-66.15	25	-91.15	-13	-53.15	260.2	Vertical	PK	Pass
2	2671.2500	-61.24	27.81	-89.05	-13	-48.24	327.2	Vertical	PK	Pass
3	5809.3750	-47.55	32.49	-80.04	-13	-34.55	357.4	Vertical	PK	Pass
4	7611.0000	-64.05	7.96	-72.01	-13	-51.05	117.6	Vertical	PK	Pass
5	9684.0000	-61.8	11.59	-73.39	-13	-48.8	227.6	Vertical	PK	Pass
6	15169.5000	-55.99	19.38	-75.37	-13	-42.99	62.6	Vertical	PK	Pass



n78(3700-3800Mhz):
Horizontal:

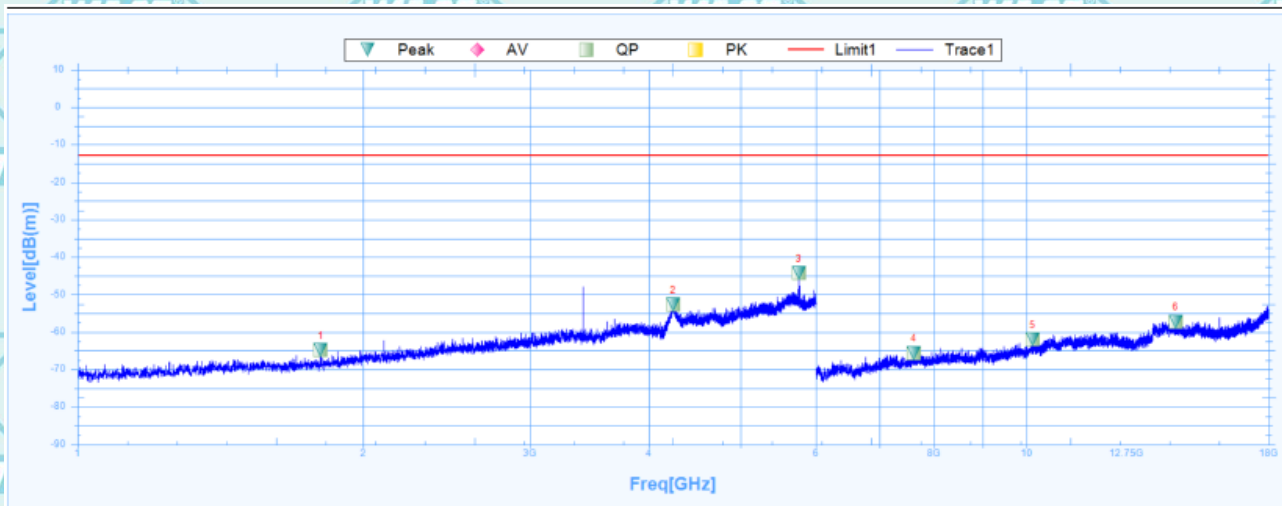

Susputed Data List

NO.	Freq. [MHz]	Level [dB(m)]	Factor [dB]	Reading [dB(m)]	Limit [dB]	Margin [dB]	Deg [°]	Polarity	Trace	Verdict
1	1804.3750	-64.83	25.02	-89.85	-13	-51.83	183.8	Horizontal	PK	Pass
2	4245.6250	-52.72	30.14	-82.86	-13	-39.72	304.6	Horizontal	PK	Pass
3	5758.1250	-44.25	32.41	-76.66	-13	-31.25	102.5	Horizontal	PK	Pass
4	7609.5000	-65.59	7.95	-73.54	-13	-52.59	224	Horizontal	PK	Pass
5	10156.5000	-61.94	12.84	-74.78	-13	-48.94	214.5	Horizontal	PK	Pass
6	14361.0000	-57.19	18.76	-75.95	-13	-44.19	360.1	Horizontal	PK	Pass



Vertical:

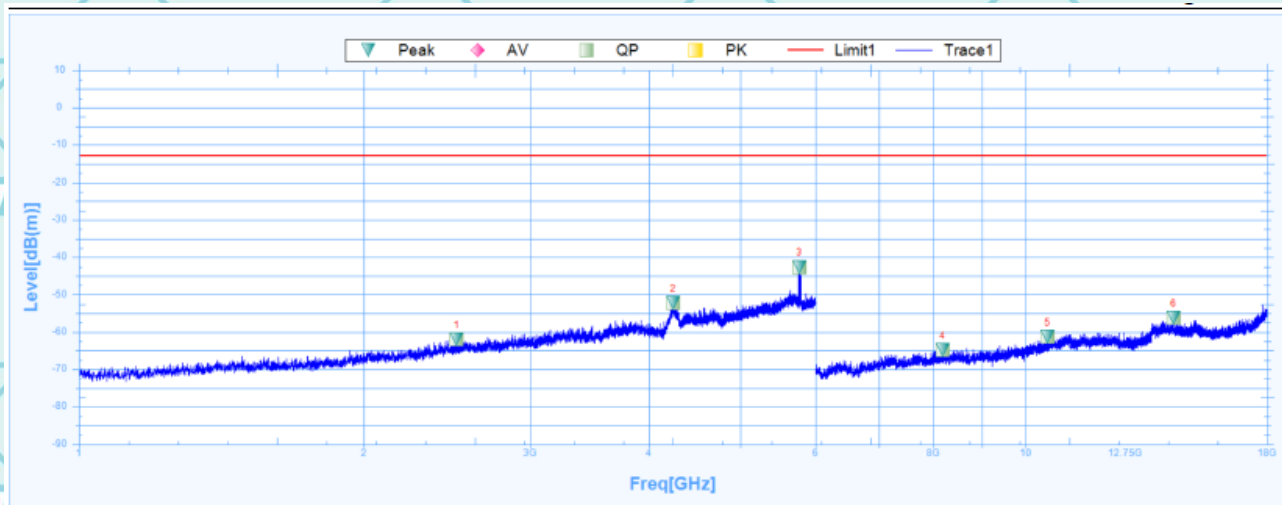

Susputed Data List

NO.	Freq. [MHz]	Level [dB(m)]	Factor [dB]	Reading [dB(m)]	Limit [dB]	Margin [dB]	Deg [°]	Polarity	Trace	Verdict
1	2506.2500	-61.95	27.61	-89.56	-13	-48.95	8.8	Vertical	PK	Pass
2	4246.8750	-52.29	30.14	-82.43	-13	-39.29	75	Vertical	PK	Pass
3	5770.6250	-42.62	32.43	-75.05	-13	-29.62	34.3	Vertical	PK	Pass
4	8176.5000	-64.87	8.69	-73.56	-13	-51.87	20.2	Vertical	PK	Pass
5	10555.5000	-61.37	14.15	-75.52	-13	-48.37	204.9	Vertical	PK	Pass
6	14337.0000	-56.24	18.78	-75.02	-13	-43.24	0.5	Vertical	PK	Pass



9. OCCUPIED BANDWIDTH & EMISSION BANDWIDTH

Test limit:

The occupied bandwidth (OBW), that is the frequency bandwidth such that, below its lower and above its upper frequency limits, the mean powers radiated are each equal to 0.5 percent of the total mean power radiated by a given emission, shall be measured when modulated by an input signal such that its amplitude and symbol rate represent the maximum rated conditions under which the equipment will be operated. The signal shall be applied through any filter networks, pseudo-random generators or other devices required in normal service. Additionally, the occupied bandwidth shall be shown for operation with any devices used for modifying the spectrum when such devices are optional at the discretion of the user. [j]2.1049(h)]

Many of the individual rule parts specify a relative OBW in lieu of the 99% OBW. In such cases, the OBW is defined as the width of the signal between two points, one below the carrier center frequency and one above the carrier center frequency, outside of which all emissions are attenuated by at least X dB below the transmitter power, where the value of X is typically specified as 26.

The relative OBW must be measured and reported when it is specified in the applicable rule part; otherwise, the 99% OBW shall be measured and reported. The test report shall specify which OBW is reported.

A spectrum/signal analyzer or other instrument providing a spectral display is recommended for these measurements and the video bandwidth shall be set to a value at least three times greater than the IF/resolution bandwidth to avoid any amplitude smoothing. Video filtering shall not be used during occupied bandwidth tests.

The OBW shall be measured for all operating conditions that will affect the bandwidth results (e.g. variable modulations, coding, or channel bandwidth settings). See section 4.

Test procedure:

Occupied bandwidth – relative measurement procedure

The reference value is the highest level of the spectral envelope of the modulated signal.

- The spectrum analyzer center frequency is set to the nominal EUT channel center frequency. The span range for the spectrum analyzer shall be between two and five times the anticipated OBW.
- The nominal resolution bandwidth (RBW) shall be in the range of 1 to 5 % of the anticipated OBW, and the VBW shall be at least 3 times the RBW.
- Set the reference level of the instrument as required to prevent the signal from exceeding the maximum input mixer level for linear operation. In general, the peak of the spectral envelope must be at least 10log (OBW / RBW) below the reference level.
- NOTE—Steps a) through c) may require iteration to adjust within the specified tolerances.
- The dynamic range of the spectrum analyzer at the selected RBW shall be at least 10 dB below the target “-X dB down” requirement (i.e., if the requirement calls for measuring the -26 dB OBW, the spectrum analyzer noise floor at the selected RBW shall be at least 36 dB below the reference value).
- Set the detection mode to peak, and the trace mode to max hold.
- Determine the reference value: Set the EUT to transmit a modulated signal. Allow the trace to stabilize. Set the spectrum analyzer marker to the highest level of the displayed trace (this is the reference value).
- Determine the “-X dB down amplitude” as equal to (Reference Value – X). Alternatively, this calculation can be performed by the analyzer by using the marker-delta function.

i) Place two markers, one at the lowest and the other at the highest frequency of the envelope of the spectral display such that each marker is at or slightly below the “-X dB down amplitude” determined in step g). If a marker is below this “-X dB down amplitude” value it shall be placed as close as possible to this value. The OBW is the positive frequency difference between the two markers.

j) The occupied bandwidth shall be reported by providing plot(s) of the measuring instrument display. The frequency and amplitude axes and scale shall be clearly labeled. Tabular data may be reported in addition to the plot(s).

Occupied bandwidth – power bandwidth (99%) measurement procedure

The following procedure shall be used for measuring (99 %) power bandwidth

a) The spectrum analyzer center frequency is set to the nominal EUT channel center frequency. The frequency span for the spectrum analyzer shall be set wide enough to capture all modulation products including the emission skirts (i.e., two to five times the OBW).

b) The nominal IF filter bandwidth (3 dB RBW) shall be in the range of 1 to 5 % of the anticipated OBW, and the VBW shall be at least 3 times the RBW.

c) Set the reference level of the instrument as required to keep the signal from exceeding the maximum input mixer level for linear operation. In general, the peak of the spectral envelope must be at least 10log (OBW / RBW) below the reference level.

d) NOTE—Steps a) through c) may require iteration to adjust within the specified tolerances.

e) Set the detection mode to peak, and the trace mode to max hold..

f) Use the 99 % power bandwidth function of the spectrum analyzer (if available) and report the measured bandwidth.

g) If the instrument does not have a 99 % power bandwidth function, the trace data points are to be recovered and directly summed in linear power terms. The recovered amplitude data points, beginning at the lowest frequency, are placed in a running sum until 0.5 % of the total is reached; that frequency is recorded as the lower frequency. The process is repeated until 99.5 % of the total is reached; that frequency is recorded as the upper frequency. The 99 % power bandwidth is the difference between these two frequencies.

h) The OBW shall be reported by providing plot(s) of the measuring instrument display. The frequency and amplitude axes and scale shall be clearly labeled. Tabular data may be reported in addition to the plot(s).

Test setup:

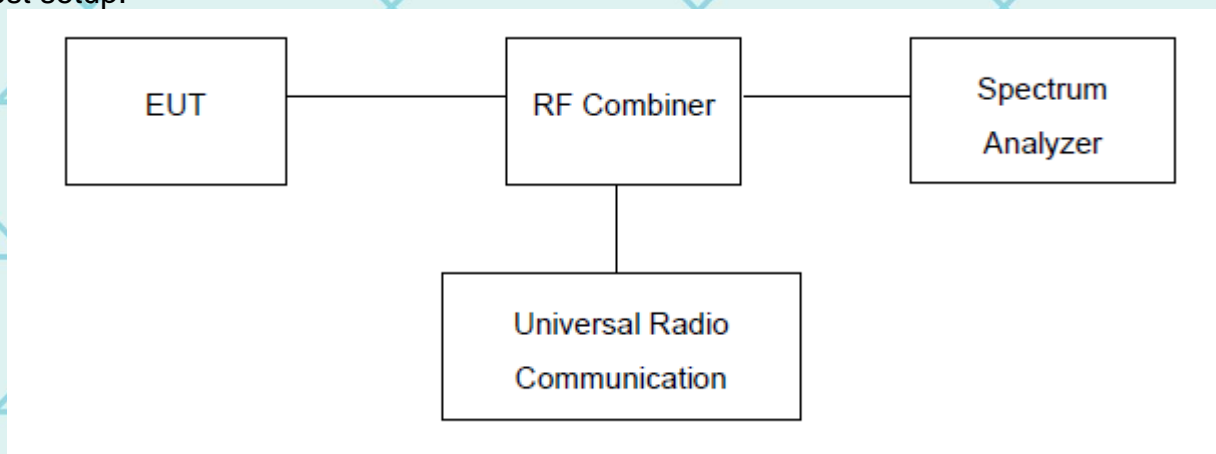

9.1. Measurement Result

Note: Please refer to Annex (GSM&WCDMA<E&NR Occupied Bandwidth) for more test data

10. BAND EDGE

Test Limit:

The radio frequency voltage or powers generated within the equipment and appearing on a spurious frequency shall be checked at the equipment output terminals when properly loaded with a suitable artificial antenna. Curves or equivalent data shall show the magnitude of each harmonic and other spurious emission that can be detected when the equipment is operated under the conditions specified in §2.1049 as appropriate. The magnitude of spurious emissions which are attenuated more than 20 dB below the permissible value need not be specified. See section 4.

Test procedure:

The RF output of the transmitter was connected to the input of the spectrum analyzer through sufficient attenuation.

Test setup:

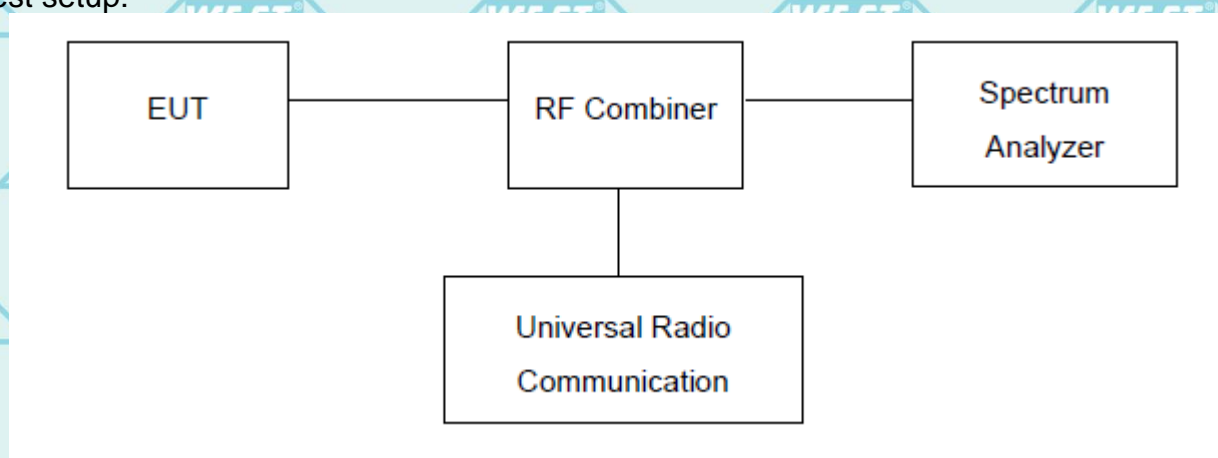

10.1. Measurement Result

Test Plot(s)

Note: Please refer to Annex (GSM&WCDMA<E&NR Band Edge) for more test data

11. SPURIOUS EMISSION (Conducted and Radiated)

11.1. Measurement Result (Pre-measurement)

GSM850:

Test Channel	BW(MHz)	UL Channel	Frequency(MHz)	Judgment
Low Range	0.2	128	824.2	Pass
Middle Range	0.2	190	836.6	Pass
High Range	0.2	251	848.8	Pass

PCS 1900 :

Test Channel	BW(MHz)	UL Channel	Frequency(MHz)	Judgment
Low Range	0.2	512	1850.2	Pass
Middle Range	0.2	661	1880.0	Pass
High Range	0.2	810	1909.8	Pass

UTRA BANDS

Band 2:

Test Channel	BW(MHz)	UL Channel	Frequency(MHz)	Judgment
Low Range	5	9262	1852.4	Pass
Middle Range	5	9400	1880.0	Pass
High Range	5	9538	1907.6	Pass

Band 4:

Test Channel	BW(MHz)	UL Channel	Frequency(MHz)	Judgment
Low Range	5	1312	1712.4	Pass
Middle Range	5	1413	1732.6	Pass
High Range	5	1513	1752.6	Pass

Band 5:

Test Channel	BW(MHz)	UL Channel	Frequency(MHz)	Judgment
Low Range	5	4132	826.4	Pass
Middle Range	5	4182	836.4	Pass
High Range	5	4233	846.6	Pass



Test Plot(s)
Conducted method

Test limit:

The spurious (unwanted) emission limits specified in the individual FCC rule parts applicable to licensed digital transmitters (typically referred to under the heading 'emission limits') normally apply to any and all emissions that are present outside of the authorized frequency band/block and apply to emissions in both the out-of-band and spurious domains. In some rule parts, the unwanted emission limits are specified by an emission mask that defines the applicable limit as a function of the frequency range relative to the authorized frequency block.

Typically, unwanted emissions are required by the licensed rule parts to be attenuated below the transmitter power by a factor of at least $X + 10\log(P)$ dB, where P represents the transmitter power expressed in watts and X is a specified scalar value (e.g., 43). This specification can be interpreted in one of two equivalent ways. First, the required attenuation can be construed to be relative to the mean carrier power, with the resultant of the equation $X + 10\log(P)$ being expressed in dBc (dB relative to the maximum carrier power). Alternatively, the specification can be interpreted as an absolute limit when the specified attenuation is actually subtracted from the maximum permissible transmitter power [i.e., $10\log(P) - \{X + 10\log(P)\}$], resulting in an absolute level of -X dBW [or $(-X + 30)$ dBm]. See section 4.

Test procedure:

The RF output of the transceiver was connected to a spectrum analyzer and simulator through appropriate attenuation. The resolution bandwidth of the spectrum analyzer was set at 100 kHz below 1 GHz and 1 MHz above 1 GHz. Sufficient scans were taken to show any out of band emissions up to 10th harmonics.

Conducted Emission Test-Up:

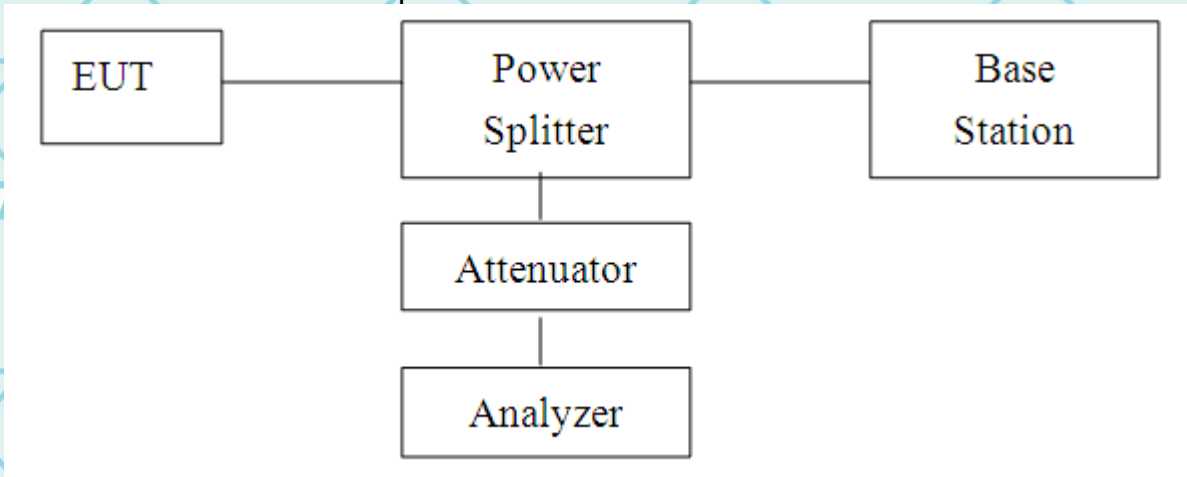

Measurement Result

Note: Please refer to Annex (GSM&WCDMA<E&NR Out-of-band emissions) for more test data



12. FREQUENCY STABILITY

Test limit:

The frequency stability of the transmitter shall be measured while varying the ambient temperatures and supply voltages over the ranges specified in §2.1055. The specific frequency stability limits are provided in the relevant rules section(s). see section 4.

Test procedure:

Frequency Stability vs. Temperature: The equipment under test was connected to an external DC power supply and the RF output was connected to communication test set via feed-through attenuators. The EUT was placed inside the temperature chamber. The DC leads and RF output cable exited the chamber through an opening made for the purpose.

Test setup:

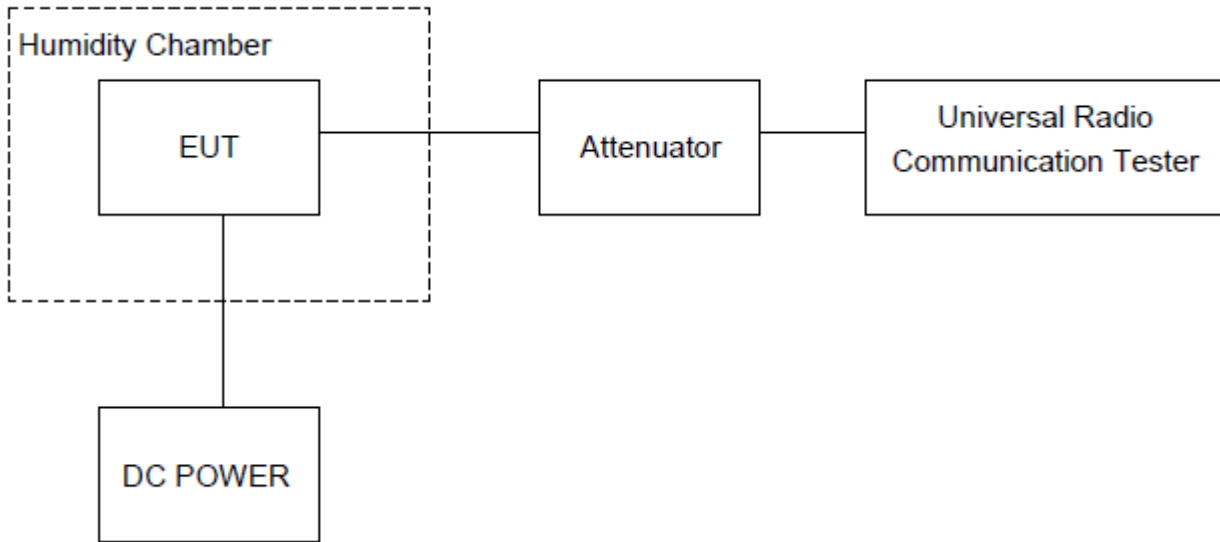

12.1. Measurement Result (Worst)

Note: Please refer to Annex (GSM&WCDMA<E&NR Frequency Error against) for more test data

13. Test Setup Photographs

Please refer to Annex "Set Up Photos-RF" for test setup photos

---END OF REPORT---

