



FCC 47 CFR PART 15 SUBPART C RF Test Report

Applicant : Roadeyes SAS
Applicant Address : 168 avenue Charles de Gaulle, 92200 Neuilly, Seine, France
Product Type : recSMART
Trade Name : RoadEyes
Model Number : recSMART
Applicable Standard : FCC 47 CFR PART 15 SUBPART C: Oct., 2014
ANSI C63.10:2013
Receive Date : Mar. 08, 2016
Test Period : Mar. 09, 2016 ~ May. 04, 2016
Issue Date : May. 06, 2016

Issue by

A Test Lab Techno Corp.
No. 140-1, Changan Street, Bade City,
Taoyuan County 334, Taiwan R.O.C.
Tel : +886-3-2710188 / Fax : +886-3-2710190



Taiwan Accreditation Eoundation accreditation number: 1330

Note: This report shall not be reproduced except in full, without the written approval of A Test Lab Techno Corp. This document may be altered or revised by A Test Lab Techno Corp. personnel only, and shall be noted in the revision section of the document. The client should not use it to claim product endorsement by TAF, or any government agencies. The test results in the report only apply to the tested sample.



Revision History

Rev.	Issue Date	Revisions	Revised By
00	May. 06, 2016	Initial Issue	



Verification of Compliance

Issued Date: 2016/05/06

Applicant : Roadeyes SAS
 Address Applicant : 168 avenue Charles de Gaulle, 92200 Neuilly, Seine, France
 Product Type : recSMART
 Trade Name : RoadEyes
 Model Number : recSMART
 FCC ID : 2ADYT-RECST1
 EUT Rated Voltage : DC 5.0V
 Test Voltage : 120 Vac / 60 Hz
 Applicable Standard : FCC 47 CFR PART 15 SUBPART C: Oct., 2014
 ANSI C63.10:2013

Test Result : Complied

Test Laboratory : Site 1:
 A Test Lab Techno Corp.
 No. 140-1, Changan Street, Bade City,
 Taoyuan County 334, Taiwan R.O.C.
 Tel : +886-3-2710188 / Fax : +886-3-2710190
 Taiwan Accreditation Foundation accreditation number: 1330
<http://www.atl-lab.com.tw/e-index.htm>
 Site 2:
 Shenzhen Academy of Metrology and Quality Inspection
 No.4 TongFa Road, Xili Town Nanshan District, Shenzhen,
 China



A Test Lab Techno Corp. tested the above equipment in accordance with the requirements set forth in the above standards. All indications of Pass/Fail in this report are opinions expressed by A Test Lab Techno Corp. based on interpretations and/or observations of test results. Measurement Uncertainties were not taken into account and are published for informational purposes only. The test results show that the equipment tested is capable of demonstrating compliance with the requirements as documented in this report.

Approved By : Fly Lu Reviewed By : Eric Ou Yang
 (Manager) (Fly Lu) (Testing Engineer) (Eric Ou Yang)



TABLE OF CONTENTS

1	General Information	6
2	EUT Description.....	7
3	Test Methodology.....	8
	3.1. Mode of Operation	8
	3.2. EUT Exercise Software.....	8
	3.3. Configuration of Test System Details	9
	3.4. Test Site Environment.....	9
4	Conducted Emission Measurement.....	10
	4.1. Limit.....	10
	4.2. Test Instruments	10
	4.3. Test Setup.....	10
	4.4. Test Procedure.....	11
	4.5. Test Result.....	12
5	Radiated Emission Measurement	14
	5.1. Limit.....	14
	5.2. Test Instruments	14
	5.3. Setup	15
	5.4. Test Procedure.....	16
	5.5. Test Result.....	18
6	Maximum Conducted Output Power Measurement.....	22
	6.1. Limit.....	22
	6.2. Test Setup.....	22
	6.3. Test Instruments	22
	6.4. Test Procedure.....	22
	6.5. Test Result.....	23
7	6dB RF Bandwidth Measurement.....	24
	7.1. Limit.....	24
	7.2. Test Setup.....	24
	7.3. Test Instruments	24
	7.4. Test Procedure.....	24
	7.5. Test Result.....	25
	7.6. Test Graphs	26
8	Maximum Power Density Measurement	29



8.1. Limit.....	29
8.2. Test Setup.....	29
8.3. Test Instruments	29
8.4. Test Procedure.....	29
8.5. Test Result.....	30
8.6. Test Graphs	31
9 Out of Band Conducted Emissions Measurement	34
9.1. Limit.....	34
9.2. Test Setup.....	34
9.3. Test Instruments	34
9.4. Test Procedure.....	34
9.5. Test Graphs	35
10 Band Edges Measurement.....	56
10.1. Limit.....	56
10.2. Test Setup.....	56
10.3. Test Instruments	56
10.4. Test Procedure.....	57
10.5. Test Result.....	58
11 Antenna Measurement	64
11.1. Limit.....	64
11.2. Antenna Connector Construction.....	64



1 General Information

1.1 Summary of Test Result

Standard	Item	Result	Remark
15.247			
15.207	AC Power Conducted Emission	PASS	----
Standard	Item	Result	Remark
15.247			
15.247(d)	Transmitter Radiated Emissions	PASS	----
15.247(b)(3)	Max. Output Power	PASS	----
15.247(a)(2)	6dB RF Bandwidth	PASS	----
15.247(e)	Power Spectral Density	PASS	----
15.247(d)	Out of Band Conducted Spurious Emission	PASS	----
15.247(d)	Band Edge Measurement	PASS	----
15.203	Antenna Requirement	PASS	----

The test results of this report relate only to the tested sample(s) identified in this report. Manufacturer or whom it may concern should recognize the pass or fail of the test result.

1.2 Measurement Uncertainty

Test Item	Frequency Range	Uncertainty (dB)	
Conducted Emission	9kHz ~ 30MHz	± 2.02	
Radiated Emission	30MHz ~ 1000MHz	Horizontal	± 3.98
		Vertical	± 3.62
	1000MHz ~ 18000MHz	Horizontal	± 3.11
		Vertical	± 3.07
	18000MHz ~ 40000MHz	Horizontal	± 3.66
		Vertical	± 3.54



2 EUT Description

Applicant	Roadeyes SAS			
Applicant Address	168 avenue Charles de Gaulle, 92200 Neuilly, Seine, France			
Manufacturer	Roadeyes SAS			
Manufacturer Address	168 avenue Charles de Gaulle, 92200 Neuilly, Seine, France			
Product Type	recSMART			
Trade Name	RoadEyes			
Model Number	recSMART			
FCC ID	2ADYT-RECST1			
Operate Freq. Band	Frequency Range (MHz)	Modulation	Channel Bandwidth	Data Rate
IEEE 802.11b	2412 ~ 2462	DSSS	20MHz	Up to 11Mbps
IEEE 802.11g	2412 ~ 2462	DSSS+OFDM	20MHz	Up to 54Mbps
IEEE 802.11n 2.4GHz 20MHz	2412 ~ 2462	OFDM	20MHz	Up to 72.2Mbps
Antenna Delivery	1TX + 1RX			
Antenna Type	FPC Antenna			
Antenna Gain	1.9 dBi			
Hardware Version	M6-Plus Rev:E			
Software Version	V3.3.0.21			
RF Output Power	IEEE 802.11b: 0.166 W /22.21 dBm IEEE 802.11g: 0.179 W / 22.54 dBm IEEE 802.11n 2.4GHz 20MHz: 0.149 W / 21.72 dBm			
99 % Occupied Bandwidth	IEEE 802.11b: 12.26 MHz IEEE 802.11g: 16.32 MHz IEEE 802.11n 2.4GHz 20MHz: 17.52 MHz			



3 Test Methodology

3.1. Mode of Operation

Decision of Test ATL has verified the construction and function in typical operation. All the test modes were carried out with the EUT in normal operation, which was shown in this test report and defined as:

Test Mode
Mode 1: Normal operation mode
Mode 2: IEEE 802.11b link mode
Mode 3: IEEE 802.11g link mode
Mode 4: IEEE 802.11n 2.4GHz 20MHz link mode

Software used to control the EUT for staying in continuous transmitting mode was programmed, and the transmit duty cycle is not less than 98%.

After verification, all tests were carried out with the worst case test modes as shown below except radiated spurious emission below 1GHz and power line conducted emissions below 30MHz, which worst case was in normal link mode only.

Test Mode	Antenna Delivery	Test Channel	Data Rate
Mode 2: IEEE 802.11b link mode	1TX / 1RX	1, 6, 11	1
Mode 3: IEEE 802.11g link mode	1TX / 1RX	1, 6, 11	6
Mode 4: IEEE 802.11n 2.4GHz 20MHz link mode	1TX / 1RX	1, 6, 11	19.5

Note: Output power and power density directional gain = GANT=1.9dBi

3.2. EUT Exercise Software

1. Setup the EUT shown on 3.3.
2. Turn on the power of all equipment.
3. Turn on Wi-Fi function link to AP.
4. EUT run test program.

3.3. Configuration of Test System Details

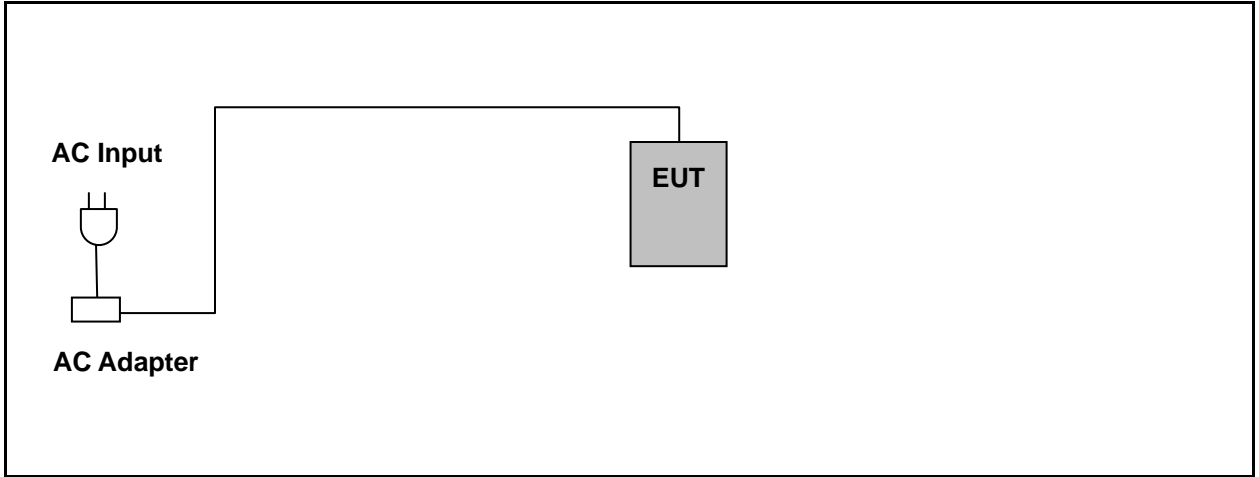

Auxiliary equipment description				
	Product	Manufacturer	Model Number	S/N
(1)	Power Adapter	Sony	--	3513W51304150
--	--	--	--	--

3.4. Test Site Environment

Items	Required (IEC 60068-1)	Actual
Temperature (°C)	15-35	26
Humidity (%RH)	25-75	60
Barometric pressure (mbar)	860-1060	950

4 Conducted Emission Measurement

4.1. Limit

Frequency (MHz)	Quasi-peak	Average
0.15 - 0.5	66 to 56	56 to 46
0.50 - 5.0	56	46
5.0 - 30.0	60	50

4.2. Test Instruments

Describe	Manufacturer	Model Number	Serial Number	Cal. Date	Remark
Test Receiver	R&S	ESCI	100367	06/06/2015	(1)
LISN	R&S	ENV216	101040	03/07/2016	(1)
LISN	R&S	ENV216	101041	03/07/2016	(1)
Test Site	ATL	TE05	TE05	N.C.R.	-----
RF cable	WOKEN	---	C.10-07-04	10/24/2015	(1)
RF cable	WOKEN	---	C.10-07-05	10/24/2015	(1)

Remark: (1) Calibration period 1 year. (2) Calibration period 2 years. (3) Calibration period 3 years.

Note: N.C.R. = No Calibration Request. All the RF cables apply to 9 KHz to 40GHz.

4.3. Test Setup

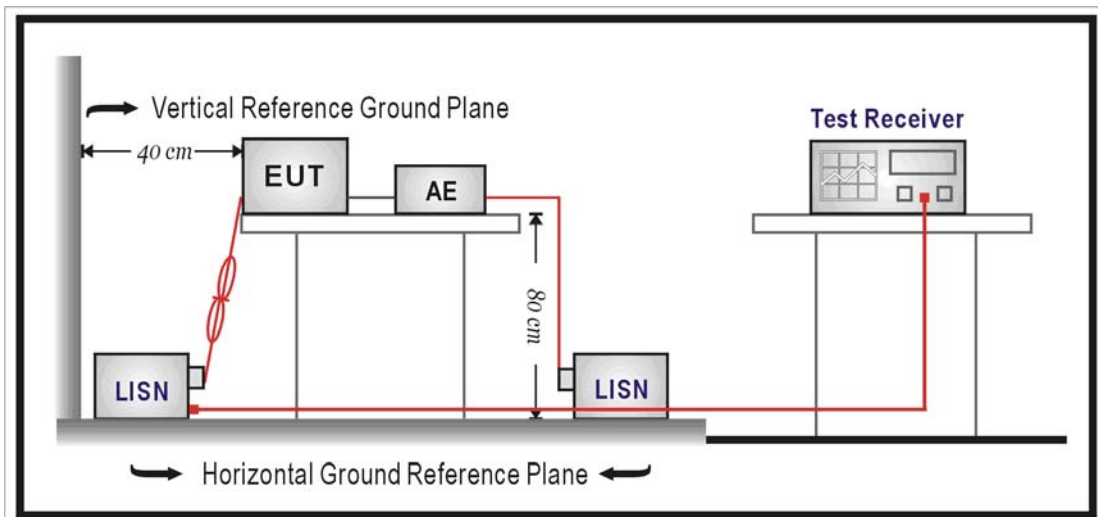



4.4. Test Procedure

The power line conducted emission measurements were performed in a shielded enclosure. The EUT was assembled on a wooden table which is 80 centimeters high, was placed 40 centimeters from the back wall and at least 1 meter from the sidewall.

Power was fed to the EUT from the public utility power grid through a line filter and EMCO Model ENV216 SH Line Impedance Stabilization Networks (LISN). The LISN housing, measuring instrumentation case, ground plane, etc., were electrically bonded together at the same RF potential. The Spectrum analyzer was connected to the AC line through an isolation transformer. The 50-ohm output of the LISN was connected to the spectrum analyzer directly. Conducted emission levels were in the CISPR quasi-peak detection mode. The analyzer's 6 dB bandwidth was set to 9 KHz. No post-detector video filter was used.

The spectrum was scanned from 150 KHz to 30 MHz. The physical arrangement of the test system and associated cabling was varied (within the scope of arrangements likely to be encountered in actual use) to determine the effect on the unit's emanations in amplitude and frequency. All spurious emission frequencies were observed. The highest emission amplitudes relative to the appropriate limit were measured and have been recorded in paragraph 4.1.



4.5. Test Result

Remark: we tested AC conducted emission both at voltage at AC 120V/60Hz and AC 240V/50Hz, recorded worst case at AC 120V/60Hz.

Standard:	FCC Part 15C	Line:	L1
Test item:	Conducted Emission	Power:	AC 120V/60Hz
Model Number:	recSMART	Temp.(°C)/Hum.(%RH):	26(°C)/60%RH
Mode:	Mode 1	Date:	04/27/2016
Description:			

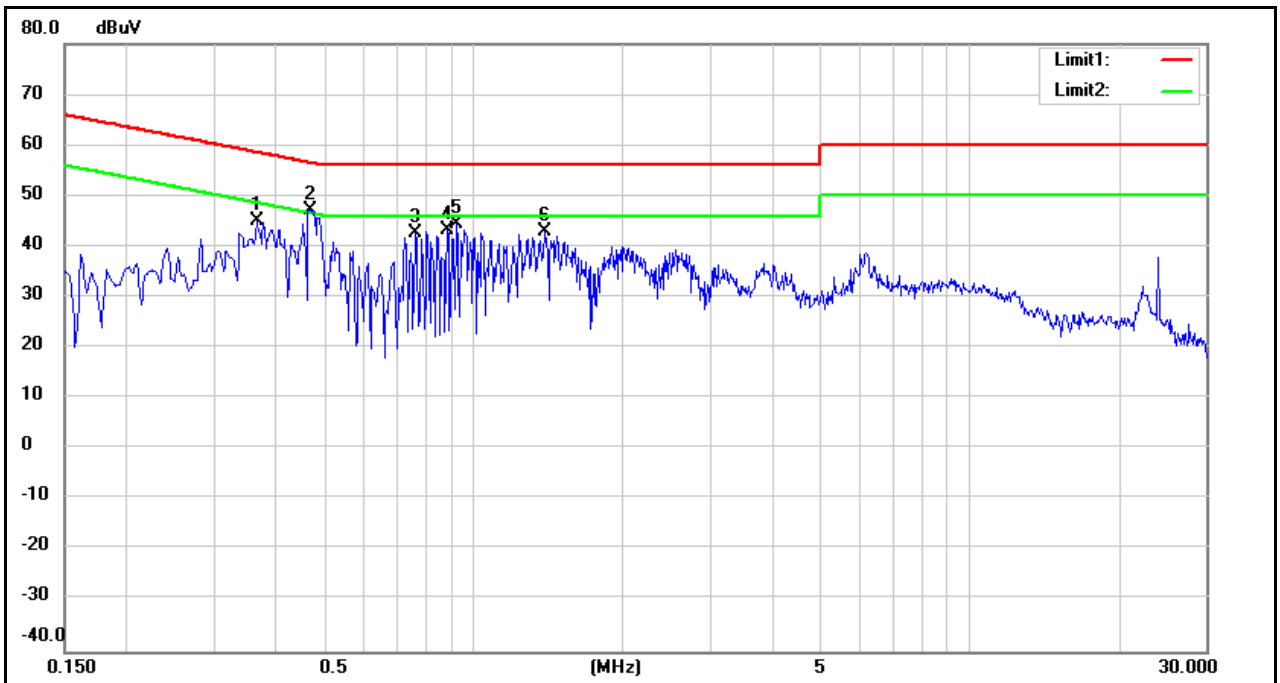

No.	Frequency (MHz)	QP reading (dBuV)	AVG reading (dBuV)	Correction factor (dB)	QP result (dBuV)	AVG result (dBuV)	QP limit (dBuV)	AVG limit (dBuV)	QP margin (dB)	AVG margin (dB)	Remark
1	0.3660	32.27	22.73	10.35	42.62	33.08	58.59	48.59	-15.97	-15.51	Pass
2	0.4700	34.88	24.46	10.35	45.23	34.81	56.51	46.51	-11.28	-11.70	Pass
3	0.7660	29.58	18.62	10.40	39.98	29.02	56.00	46.00	-16.02	-16.98	Pass
4	0.8860	29.06	17.41	10.40	39.46	27.81	56.00	46.00	-16.54	-18.19	Pass
5	0.9260	30.72	19.97	10.39	41.11	30.36	56.00	46.00	-14.89	-15.64	Pass
6	1.3940	28.41	17.59	10.41	38.82	28.00	56.00	46.00	-17.18	-18.00	Pass

Note: 1. Result (dBuV) = Correction factor (dB) + Reading (dBuV).

2. Correction factor (dB) = Cable loss (dB) + L.I.S.N. factor (dB).



Standard:	FCC Part 15C	Line:	N
Test item:	Conducted Emission	Power:	AC 120V/60Hz
Model Number:	recSMART	Temp.(°C)/Hum.(%RH):	26(°C)/60%RH
Mode:	Mode 1	Date:	04/27/2016
Description:			

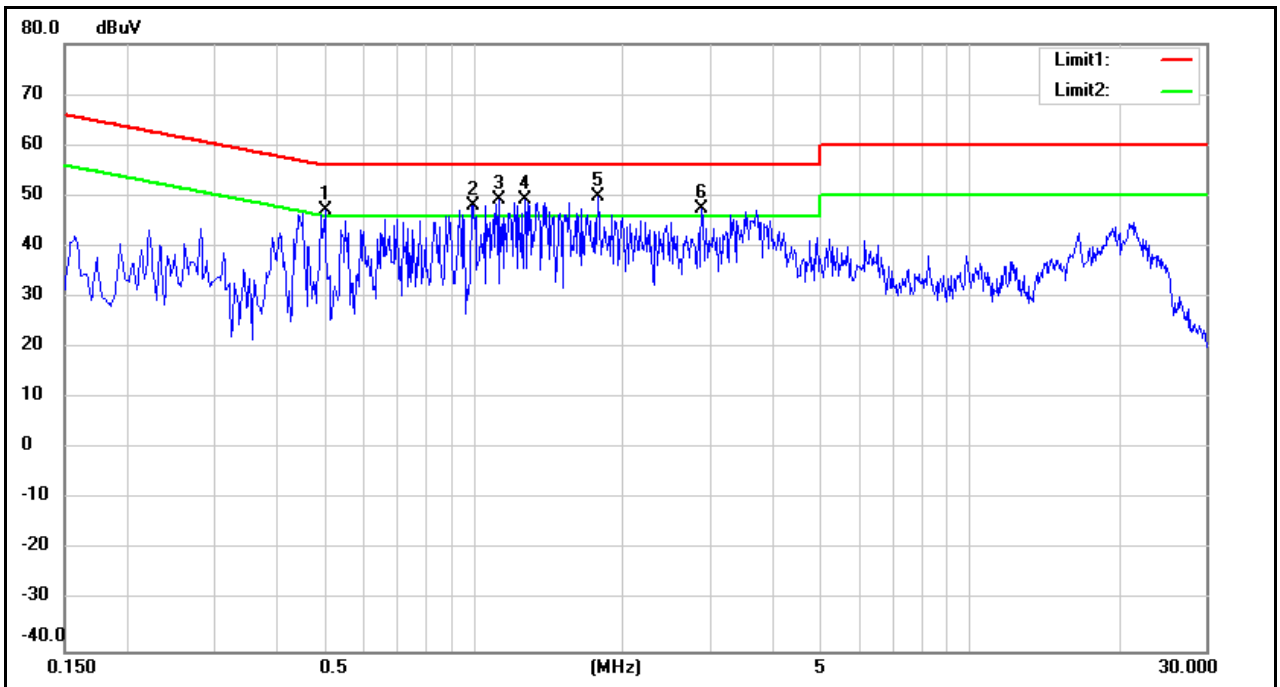

No.	Frequency (MHz)	QP reading (dBuV)	AVG reading (dBuV)	Correction factor (dB)	QP result (dBuV)	AVG result (dBuV)	QP limit (dBuV)	AVG limit (dBuV)	QP margin (dB)	AVG margin (dB)	Remark
1	0.5020	35.93	27.06	10.35	46.28	37.41	56.00	46.00	-9.72	-8.59	Pass
2	0.9940	34.98	24.69	10.38	45.36	35.07	56.00	46.00	-10.64	-10.93	Pass
3	1.1340	31.39	18.48	10.39	41.78	28.87	56.00	46.00	-14.22	-17.13	Pass
4	1.2700	34.81	21.74	10.40	45.21	32.14	56.00	46.00	-10.79	-13.86	Pass
5	1.7820	32.28	18.81	10.44	42.72	29.25	56.00	46.00	-13.28	-16.75	Pass
6	2.8980	31.34	16.32	10.49	41.83	26.81	56.00	46.00	-14.17	-19.19	Pass

Note: 1. Result (dBuV) = Correction factor (dB) + Reading (dBuV).

2. Correction factor (dB) = Cable loss (dB) + L.I.S.N. factor (dB).



5 Radiated Emission Measurement

5.1. Limit

According to §15.209(a), except as provided elsewhere in this subpart, the emissions from an intentional radiator shall not exceed the field strength levels specified in the following table:

Frequency (MHz)	Field Strength ($\mu\text{V}/\text{m}$ at meter)	Measurement Distance (meters)
0.009 – 0.490	2400 / F (kHz)	300
0.490 – 1.705	24000 / F (kHz)	30
1.705 – 30.0	30	30
30 - 88	100**	3
88-216	150**	3
216-960	200**	3
Above 960	500	3

** Except as provided in paragraph (g), fundamental emissions from intentional radiators operating under this Section shall not be located in the frequency bands 54-72 MHz, 76-88 MHz, 174-216 MHz or 470-806 MHz. However, operation within these frequency bands is permitted under other sections of this Part, e.g., Sections 15.231 and 15.241.

5.2. Test Instruments

3 Meter Chamber					
Model No.	Equipment	Manufacturer	Serial Number	Cal. Date	Remark
ESCS30	EMI Test Receiver	Rohde & Schwarz	830245/009	Dec.29, 2015	(1)
VULB9163	Bilog Antenna	Schwarzbeck	264	Jan.19, 2016	(1)
9X6X6	3m Semi-anechoic chamber	Albatross Projects	SB3450/01	Oct.12, 2015	(1)
HF907	Horn Antenna	Rohde & Schwarz	100309	May.15,2015	(1)
FMZB1516	Loop Antenna	Schwarzbeck	113	Jan 21,2016	(1)
3160-09	Horn antenna	ETS	8501/10	May.15.2015	(1)
SCU26	Pre Amplifier	Rohde & Schwarz	10020	May.15.2015	(1)
SCU40	Pre Amplifier	Rohde & Schwarz	10015	May.15.2015	(1)
ESU40	Test Receiver	Rohde & Schwarz	100263	May.15.2015	(1)
---	RF cable	WOKEN	S02-1404-09-065	May.11.2015	(1)
---	RF cable	WOKEN	S02-1404-09-047	May.11.2015	(1)
---	RF cable	WOKEN	S02-1404-09-052	May.11.2015	(1)

Remark: (1) Calibration period 1 year. (2) Calibration period 2 years. (3) Calibration period 3 years.

Note: N.C.R. = No Calibration Request. All the RF cables apply to 9 KHz to 40GHz.

5.3. Setup

9 kHz ~ 30MHz

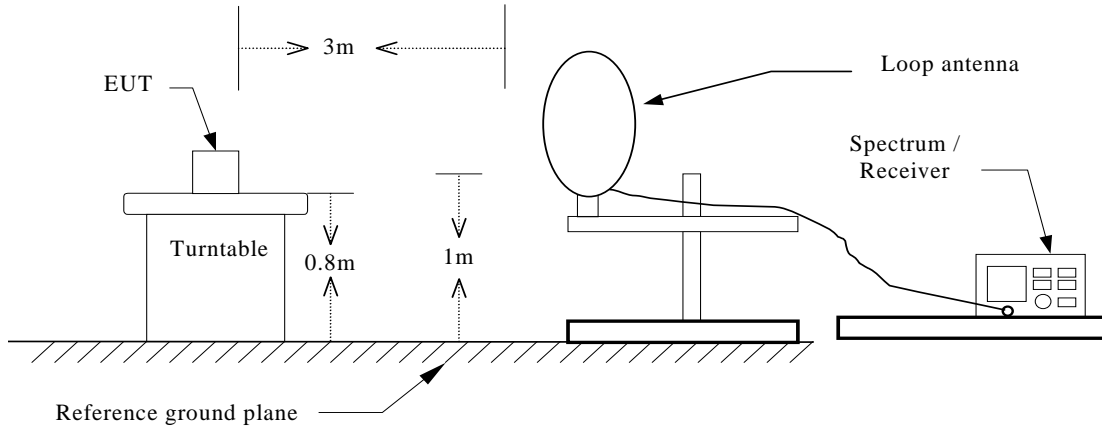

Below 1GHz

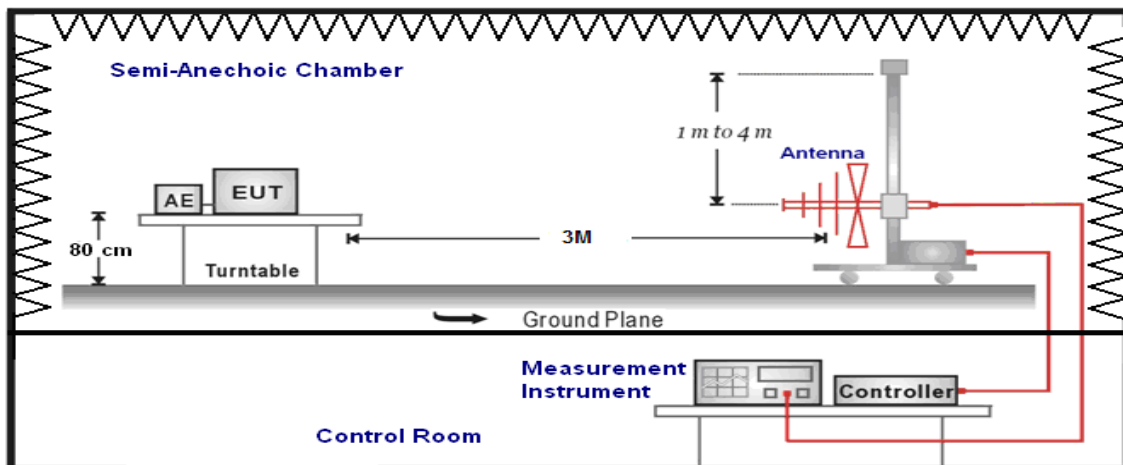

Above 1GHz

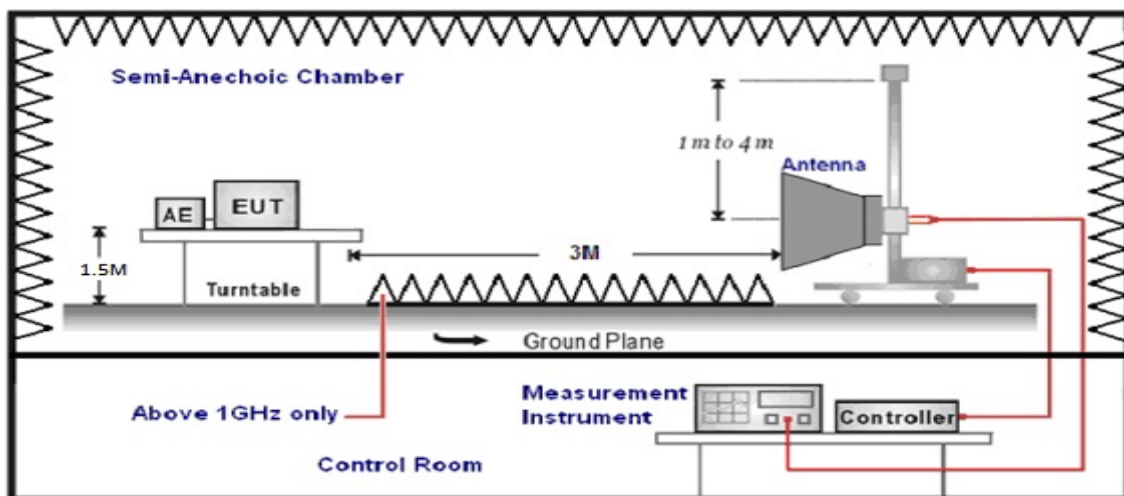



5.4. Test Procedure

Final radiation measurements were made on a three-meter, Semi Anechoic Chamber. The EUT system was placed on a nonconductive turntable which is 0.8 or 1.5 meters height (below 1GHz use 0.8m turntable / above 1GHz use 1.5m turntable), top surface 1.0 x 1.5 meter. The spectrum was examined from 250 MHz to 2.5 GHz in order to cover the whole spectrum below 10th harmonic which could generate from the EUT. During the test, EUT was set to transmit continuously & Measurements spectrum range from 9 kHz to 26.5 GHz is investigated.

For measurements below 1 GHz the resolution bandwidth is set to 100 kHz for peak detection measurements or 120 kHz for quasi-peak detection measurements. Peak detection is used unless otherwise noted as quasi-peak.

For measurements above 1 GHz the resolution bandwidth is set to 1 MHz, and then the video bandwidth is set to 1 MHz for peak measurements and 10 Hz for average measurements when Duty cycle >0.98 / 1/T for average measurements when Duty cycle <0.98. A nonconductive material surrounded the EUT to supporting the EUT for standing on three orthogonal planes. At each condition, the EUT was rotated 360 degrees, and the antenna was raised and lowered from one to four meters to find the maximum emission levels. Measurements were taken using both horizontal and vertical antenna polarization.

SCHWARZBECK MESS-ELEKTRONIK Biconilog Antenna (mode VULB9163) at 3 Meter and the SCHWARZBECK Double Ridged Guide Antenna (model BBHA9120D&9170) was used in frequencies 1 – 26.5 GHz at a distance of 1 meter. All test results were extrapolated to equivalent signal at 3 meters utilizing an inverse linear distance extrapolation Factor (20dB/decade).

For testing above 1GHz, the emission level of the EUT in peak mode was 20dB lower than average limit (that means the emission level in peak mode also complies with the limit in average mode), then testing will be stopped and peak values of EUT will be reported, otherwise, the emissions will be measured in average mode again and reported.

Appropriate preamplifiers were used for improving sensitivity and precautions were taken to avoid overloading or desensitizing the spectrum analyzer. No post – detector video filters were used in the test.

The spectrum analyzer's 6 dB bandwidth was set to 1 MHz, and the analyzer was operated in the peak detection mode, for frequencies both below and up 1 GHz. The average levels were obtained by subtracting the duty cycle correction factor from the peak readings.

The following procedures were used to convert the emission levels measured in decibels referenced to 1 microvolt (dBuV) into field intensity in micro volts pre meter (uV/m).

The actual field intensity in decibels referenced to 1 microvolt in to field intensity in micro volts per meter (dBuV/m).



The actual field intensity in referenced to 1 microvolt per meter (dBuV/m) is determined by algebraically adding the measured reading in dBuV, the antenna factor (dB), and cable loss (dB) and Subtracting the gain of preamplifier (dB) is auto calculate in spectrum analyzer.

(1) $\text{Amplitude (dBuV/m)} = \text{FI (dBuV)} + \text{AF (dBuV)} + \text{CL (dBuV)} - \text{Gain (dB)}$

FI= Reading of the field intensity.

AF= Antenna factor.

CL= Cable loss.

P.S Amplitude is auto calculate in spectrum analyzer.

(2) $\text{Actual Amplitude (dBuV/m)} = \text{Amplitude (dBuV)} - \text{Dis(dB)}$

The FCC specified emission limits were calculated according the EUT operating frequency and by following linear interpolation equations:

(a) For fundamental frequency : Transmitter Output < +30dBm

(b) For spurious frequency : Spurious emission limits = fundamental emission limit /10

Data of measurement within this frequency range without mark in the table above means the reading of emissions are attenuated more than 20dB below the permissible limits or the field strength is too small to be measured.



5.5. Test Result

Below 1GHz

Standard:	FCC Part 15C	Test Distance:	3m
Test item:	Radiated Emission	Power:	AC 120V/60Hz
Model Number:	recSMART	Temp.(°C)/Hum.(%RH):	26(°C)/60%RH
Mode:	Mode 1	Date:	03/18/2016

Frequency (MHz)	Reading (dBuV)	Correct Factor (dB/m)	Result (dBuV/m)	Limit (dBuV/m)	Margin (dB)	Remark	Ant.Polar. H / V
121.3000	40.13	-15.76	24.37	43.50	-19.13	QP	H
196.5000	44.97	-14.93	30.04	43.50	-13.46	QP	H
297.7000	47.55	-10.91	36.64	46.00	-9.36	QP	H
446.3000	36.59	-7.86	28.73	46.00	-17.27	QP	H
647.2000	43.13	-3.71	39.42	46.00	-6.58	QP	H
741.5000	32.82	-1.63	31.19	46.00	-14.81	QP	H
121.3000	49.58	-15.76	33.82	43.50	-9.68	QP	V
196.5000	46.51	-14.93	31.58	43.50	-14.42	QP	V
297.7000	51.26	-10.91	40.35	46.00	-5.65	QP	V
446.3000	40.21	-7.86	32.35	46.00	-14.65	QP	V
647.2000	43.77	-3.71	40.06	46.00	-5.94	QP	V
741.5000	38.12	-1.63	36.49	46.00	-9.51	QP	V

Note: No emission found between lowest internal used/generated frequencies to 30MHz (9 kHz~30MHz).



Above 1GHz

Standard:	FCC Part 15C	Test Distance:	3m
Test item:	Radiated Emission	Power:	AC 120V/60Hz
Model Number:	recSMART	Temp.(°C)/Hum.(%RH):	26(°C)/60%RH
Mode:	Mode 2	Date:	03/18/2016
Frequency:	2412MHz		

Frequency (MHz)	Reading (dBuV)	Correct Factor (dB/m)	Result (dBuV/m)	Limit (dBuV/m)	Margin (dB)	Remark	Ant.Polar. H / V
4824.000	49.02	3.61	52.63	74	21.37	peak	H
4824.000	39.51	3.61	43.12	54	10.88	Average	H
4824.000	44.31	3.61	47.92	74	26.97	peak	V
4824.000	34.85	3.61	38.46	54	12.85	Average	V

Standard:	FCC Part 15C	Test Distance:	3m
Test item:	Radiated Emission	Power:	AC 120V/60Hz
Model Number:	recSMART	Temp.(°C)/Hum.(%RH):	26(°C)/60%RH
Mode:	Mode 2	Date:	03/18/2016
Frequency:	2437MHz		

Frequency (MHz)	Reading (dBuV)	Correct Factor (dB/m)	Result (dBuV/m)	Limit (dBuV/m)	Margin (dB)	Remark	Ant.Polar. H / V
4874.000	58.60	3.74	62.34	74	-11.66	peak	H
4874.000	47.55	3.74	51.29	54	-2.71	Average	H
4874.000	56.18	3.74	59.92	74	-14.08	peak	V
4874.000	45.90	3.74	49.64	54	-4.36	Average	V

Standard:	FCC Part 15C	Test Distance:	3m
Test item:	Radiated Emission	Power:	AC 120V/60Hz
Model Number:	recSMART	Temp.(°C)/Hum.(%RH):	26(°C)/60%RH
Mode:	Mode 2	Date:	03/18/2016
Frequency:	2462MHz		

Frequency (MHz)	Reading (dBuV)	Correct Factor (dB/m)	Result (dBuV/m)	Limit (dBuV/m)	Margin (dB)	Remark	Ant.Polar. H / V
4924.000	59.83	3.86	63.69	74	-10.31	peak	H
4924.000	48.01	3.86	51.87	54	-2.13	Average	H
4924.000	58.65	3.86	62.51	74	-11.49	peak	V
4924.000	47.70	3.86	51.56	54	-2.44	Average	V



Standard:	FCC Part 15C			Test Distance:	3m		
Test item:	Radiated Emission			Power:	AC 120V/60Hz		
Model Number:	recSMART			Temp.(°C)/Hum.(%RH):	26(°C)/60%RH		
Mode:	Mode 3			Date:	03/18/2016		
Frequency:	2412MHz						
Frequency (MHz)	Reading (dBuV)	Correct Factor (dB/m)	Result (dBuV/m)	Limit (dBuV/m)	Margin (dB)	Remark	Ant.Polar. H / V
4824.000	41.71	3.61	45.32	74	-28.68	peak	H
4824.000	34.60	3.61	38.21	54	-15.79	Average	H
4824.000	38.23	3.61	41.84	74	-32.16	peak	V
4824.000	30.68	3.61	34.29	54	-19.71	Average	V

Standard:	FCC Part 15C			Test Distance:	3m		
Test item:	Radiated Emission			Power:	AC 120V/60Hz		
Model Number:	recSMART			Temp.(°C)/Hum.(%RH):	26(°C)/60%RH		
Mode:	Mode 3			Date:	03/18/2016		
Frequency:	2437MHz						
Frequency (MHz)	Reading (dBuV)	Correct Factor (dB/m)	Result (dBuV/m)	Limit (dBuV/m)	Margin (dB)	Remark	Ant.Polar. H / V
4874.000	42.02	3.74	45.76	74	-28.24	peak	H
4874.000	33.24	3.74	36.98	54	-17.02	Average	H
4874.000	43.67	3.74	47.41	74	-26.59	peak	V
4874.000	34.72	3.74	38.46	54	-15.54	Average	V

Standard:	FCC Part 15C			Test Distance:	3m		
Test item:	Radiated Emission			Power:	AC 120V/60Hz		
Model Number:	recSMART			Temp.(°C)/Hum.(%RH):	26(°C)/60%RH		
Mode:	Mode 3			Date:	03/18/2016		
Frequency:	2462MHz						
Frequency (MHz)	Reading (dBuV)	Correct Factor (dB/m)	Result (dBuV/m)	Limit (dBuV/m)	Margin (dB)	Remark	Ant.Polar. H / V
4924.000	45.77	3.86	49.63	74	-24.37	peak	H
4924.000	37.26	3.86	41.12	54	-12.88	Average	H
4924.000	44.12	3.86	47.98	74	-26.02	peak	V
4924.000	34.56	3.86	38.42	54	-15.58	Average	V



Standard:	FCC Part 15C	Test Distance:	3m				
Test item:	Radiated Emission	Power:	AC 120V/60Hz				
Model Number:	recSMART	Temp.(°C)/Hum.(%RH):	26(°C)/60%RH				
Mode:	Mode 4	Date:	03/18/2016				
Frequency:	2412MHz						
Frequency (MHz)	Reading (dBuV)	Correct Factor (dB/m)	Result (dBuV/m)	Limit (dBuV/m)	Margin (dB)	Remark	Ant.Polar. H / V
4824.000	41.25	3.61	44.86	74	-29.14	peak	H
4824.000	32.86	3.61	36.47	54	-17.53	Average	H
4824.000	39.31	3.61	42.92	74	-31.08	peak	V
4824.000	29.85	3.61	33.46	54	-20.54	Average	V

Standard:	FCC Part 15C	Test Distance:	3m				
Test item:	Radiated Emission	Power:	AC 120V/60Hz				
Model Number:	recSMART	Temp.(°C)/Hum.(%RH):	26(°C)/60%RH				
Mode:	Mode 4	Date:	03/18/2016				
Frequency:	2437MHz						
Frequency (MHz)	Reading (dBuV)	Correct Factor (dB/m)	Result (dBuV/m)	Limit (dBuV/m)	Margin (dB)	Remark	Ant.Polar. H / V
4874.000	40.89	3.74	44.63	74	-29.37	peak	H
4874.000	31.38	3.74	35.12	54	-18.88	Average	H
4874.000	40.18	3.74	43.92	74	-30.08	peak	V
4874.000	30.72	3.74	34.46	54	-19.54	Average	V

Standard:	FCC Part 15C	Test Distance:	3m				
Test item:	Radiated Emission	Power:	AC 120V/60Hz				
Model Number:	recSMART	Temp.(°C)/Hum.(%RH):	26(°C)/60%RH				
Mode:	Mode 4	Date:	03/18/2016				
Frequency:	2462MHz						
Frequency (MHz)	Reading (dBuV)	Correct Factor (dB/m)	Result (dBuV/m)	Limit (dBuV/m)	Margin (dB)	Remark	Ant.Polar. H / V
4924.000	43.95	3.86	47.81	74	-26.19	peak	H
4924.000	36.20	3.86	40.06	54	-13.94	Average	H
4924.000	43.06	3.86	46.92	74	-27.08	peak	V
4924.000	35.12	3.86	38.98	54	-15.02	Average	V

6 Maximum Conducted Output Power Measurement

6.1. Limit

For systems using digital modulation in the 2400-2483.5MHz, the limit for maximum output power is 30dBm.

6.2. Test Setup

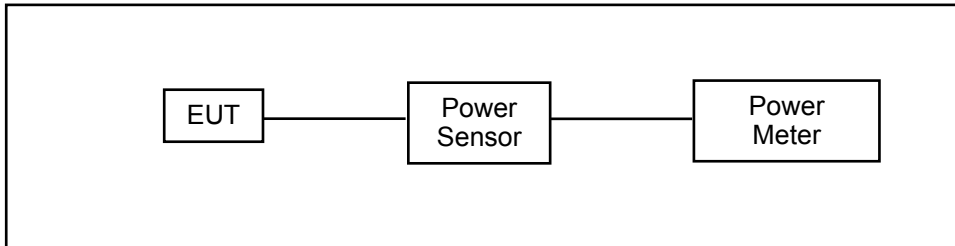

6.3. Test Instruments

Equipment	Manufacturer	Model Number	Serial Number	Cal. Date	Remark
Single Channel PK Power Sensor	Agilent	N1911A	MY45101619	12/15/2015	(1)
Wideband Power Meter	Agilent	N1921A	MY45241957	12/15/2015	(1)
Test Site	ATL	TE02	TE02	N.C.R.	-----
RF cable	WOKEN	---	C.10-07-02	10/24/2015	(1)
RF cable	WOKEN	---	C.10-07-03	10/24/2015	(1)
Temporary antenna connector	---	---	A01-224	05/24/2015	(1)

Remark: (1) Calibration period 1 year. (2) Calibration period 2 years.

NOTE: N.C.R. = No Calibration Request.

All the RF cables apply to 9 KHz to 40GHz. The temporary antenna connector is soldered on the PCB board in order to perform conducted tests and this temporary antenna connector is listed in the equipment list.

6.4. Test Procedure

The tests below are run with the EUT's transmitter set at high power in TX mode. The EUT is needed to force selection of output power level and channel number. While testing, EUT was set to transmit continuously. Remove the Subjective device's antenna and connect the RF output port to power sensor. The maximum output power shall not exceed 1 watt.

Use a direct connection between the antenna port of transmitter and the power sensor, for prevent the power sensor input attenuation 40-50 dB. Set the RBW Bandwidth of the emission or use a channel power meter mode.

For antennas with gains of 6 dBi or less, maximum allowed transmitter output is 1 watt (+30 dBm). For antennas with gains greater than 6 dBi, transmitter output level must be decreased by an amount equal to (GAIN - 6)/3 dBm.

The antenna port of the EUT was connected to the input of a power sensor. Power was read directly and cable loss correction was added to the reading to obtain power at the EUT antenna terminals.



6.5. Test Result

Model Number	recSMART		
Test Item	Maximum Conducted Output Power		
Test Mode	Mode 2: IEEE 802.11b link mode		
Date of Test	2016/03/09	Test Site	TE05
Frequency (MHz)	Peak Power		Limit (dBm)
	(dBm)	(W)	
2412	22.21	0.166	< 30
2437	22.13	0.163	< 30
2462	22.00	0.158	< 30

Model Number	recSMART		
Test Item	Maximum Conducted Output Power		
Test Mode	Mode 3: IEEE 802.11g link mode		
Date of Test	2016/03/09	Test Site	TE05
Frequency (MHz)	Peak Power		Limit (dBm)
	(dBm)	(W)	
2412	22.34	0.171	< 30
2437	22.54	0.179	< 30
2462	22.35	0.172	< 30

Model Number	recSMART		
Test Item	Maximum Conducted Output Power		
Test Mode	Mode 4: IEEE 802.11n 2.4GHz 20MHz link mode		
Date of Test	2016/03/09	Test Site	TE05
Frequency (MHz)	Peak Power		Limit (dBm)
	(dBm)	(W)	
2412	21.62	0.145	< 30
2437	21.72	0.149	< 30
2462	21.57	0.144	< 30

7 6dB RF Bandwidth Measurement

7.1. Limit

6dB RF Bandwidth: Systems using digital modulation techniques may operate in the 2400–2483.5 MHz bands. The minimum 6 dB band-width shall be at least 500 kHz.

7.2. Test Setup

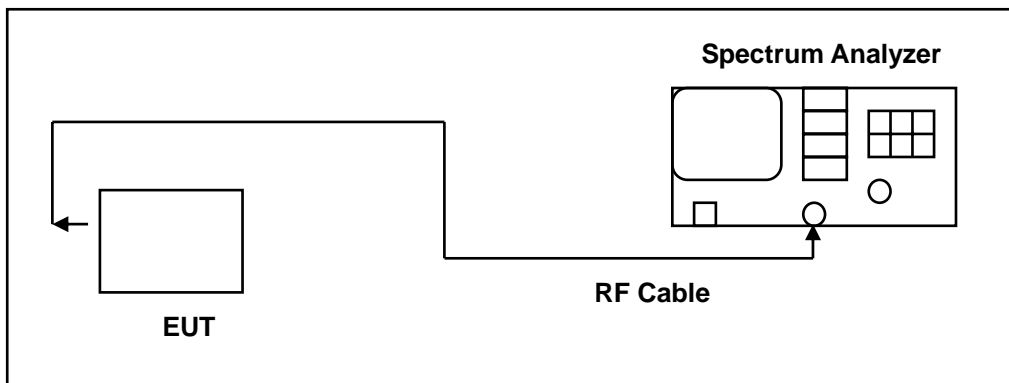

7.3. Test Instruments

Equipment	Manufacturer	Model Number	Serial Number	Cal. Date	Remark
Spectrum Analyzer	Agilent	N9020A	MY53420615	05/12/2015	(1)
Test Site	ATL	TE05	TE05	N.C.R.	-----
RF cable	WOKEN	---	C.10-07-02	10/24/2015	(1)
RF cable	WOKEN	---	C.10-07-03	10/24/2015	(1)
Temporary antenna connector	---	---	A01-224	05/24/2015	(1)

Remark: (1) Calibration period 1 year. (2) Calibration period 2 years.

NOTE: N.C.R. = No Calibration Request.

All the RF cables apply to 9 KHz to 40GHz. The temporary antenna connector is soldered on the PCB board in order to perform conducted tests and this temporary antenna connector is listed in the equipment list.

7.4. Test Procedure

The EUT tested to DTS test procedure of KDB558074D01 for compliance to FCC 47CFR 15.247 requirements.

6dB RF Bandwidth: The antenna port of the EUT was connected to the input of a spectrum analyzer. Analyzer RES RBW was set to 100 kHz. For each RF output channel investigated, the spectrum analyzer center frequency was set to the channel carrier. A peak output reading was taken, a DISPLAY line was drawn 6 dB lower than peak level. The 6 dB bandwidth was determined from where the channel output spectrum intersected the display line.

The test was performed at 3 channels (Channel low, middle, high)

99 % Occupied Bandwidth: The transmitter shall be operated at its maximum carrier power measured under normal test conditions.

The video bandwidth shall be set to 3 times the resolution bandwidth. Video averaging is not permitted. Where



practical, a sampling detector shall be used since a peak or, peak hold, may produce a wider bandwidth than actual. The trace data points are recovered and are directly summed in linear terms. The recovered amplitude data points, beginning at the lowest frequency, are placed in a running sum until 0.5% of the total is reached and that frequency recorded. The process is repeated for the highest frequency data points. This frequency is recorded.

7.5. Test Result

Model Number	recSMART		
Test Item	6dB RF Bandwidth		
Test Mode	Mode 2: IEEE 802.11b link mode Mode 3: IEEE 802.11g link mode Mode 4: IEEE 802.11n 2.4GHz 20MHz link mode		
Date of Test	2016/03/09	Test Site	TE05
Test Mode	Frequency (MHz)	Measurement (MHz)	Limit (MHz)
Mode 2	2412	7.580	> 0.500
	2437	8.001	> 0.500
	2462	8.219	> 0.500
Mode 3	2412	16.05	> 0.500
	2437	15.68	> 0.500
	2462	15.73	> 0.500
Mode 4	2412	16.87	> 0.500
	2437	16.01	> 0.500
	2462	16.29	> 0.500



7.6. Test Graphs

Mode 2: IEEE 802.11b link mode	
2412	<p>Agilent Spectrum Analyzer - Occupied BW Center Freq 2.412000000 GHz Center Freq: 2.412000000 GHz Trig: Free Run #Atten: 40 dB Avg/Hold: 10/10 Radio Std: None Radio Device: BTS</p> <p>Ref Offset 3.75 dB Ref 30.00 dBm</p> <p>Center 2.412 GHz #Res BW 100 kHz #VBW 300 kHz Span 30 MHz Sweep 3.2 ms</p> <p>Occupied Bandwidth 12.260 MHz Total Power 23.4 dBm</p> <p>Transmit Freq Error -30.177 kHz OBW Power 99.00 % x dB Bandwidth 7.580 MHz x dB -6.00 dB</p>
2437	<p>Agilent Spectrum Analyzer - Occupied BW Center Freq 2.437000000 GHz Center Freq: 2.437000000 GHz Trig: Free Run #Atten: 40 dB Avg/Hold: 10/10 Radio Std: None Radio Device: BTS</p> <p>Ref Offset 3.75 dB Ref 30.00 dBm</p> <p>Center 2.437 GHz #Res BW 100 kHz #VBW 300 kHz Span 40 MHz Sweep 4.267 ms</p> <p>Occupied Bandwidth 12.196 MHz Total Power 23.3 dBm</p> <p>Transmit Freq Error 2.370 kHz OBW Power 99.00 % x dB Bandwidth 8.001 MHz x dB -6.00 dB</p>
2462	<p>Agilent Spectrum Analyzer - Occupied BW Center Freq 2.462000000 GHz Center Freq: 2.462000000 GHz Trig: Free Run #Atten: 40 dB Avg/Hold: 10/10 Radio Std: None Radio Device: BTS</p> <p>Ref Offset 3.75 dB Ref 30.00 dBm</p> <p>Center 2.462 GHz #Res BW 100 kHz #VBW 300 kHz Span 40 MHz Sweep 4.267 ms</p> <p>Occupied Bandwidth 12.195 MHz Total Power 23.1 dBm</p> <p>Transmit Freq Error -60.711 kHz OBW Power 99.00 % x dB Bandwidth 8.219 MHz x dB -6.00 dB</p>



Mode 3: IEEE 802.11g link mode

2412



2437

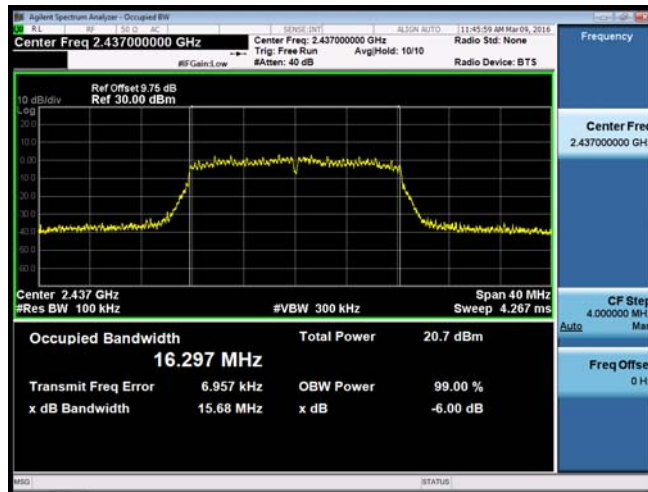

2462

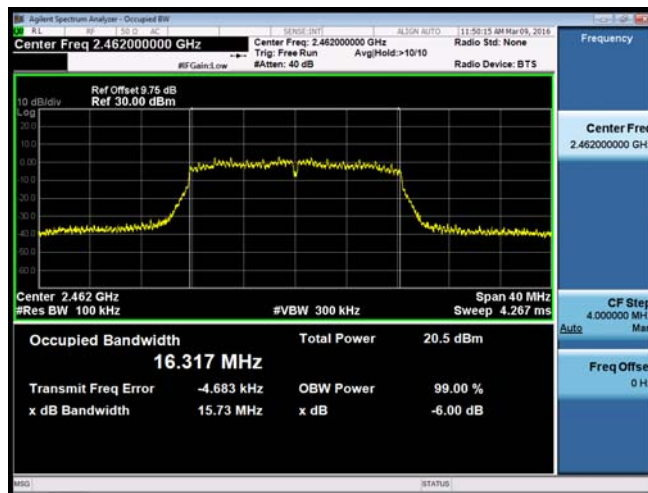



Mode 4: IEEE 802.11n 2.4GHz 20MHz link mode

2412

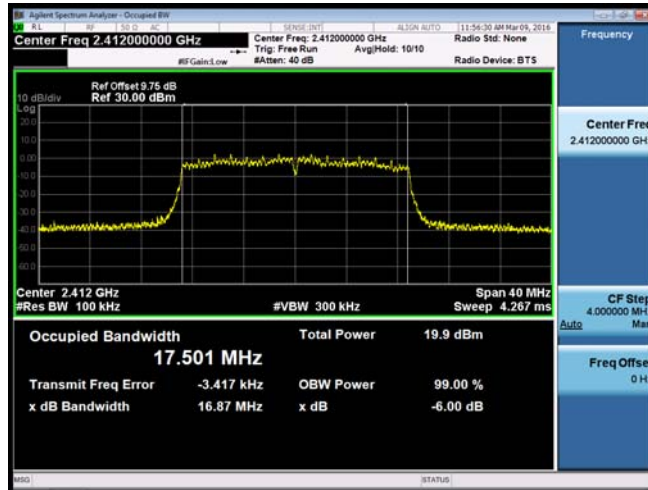

2437

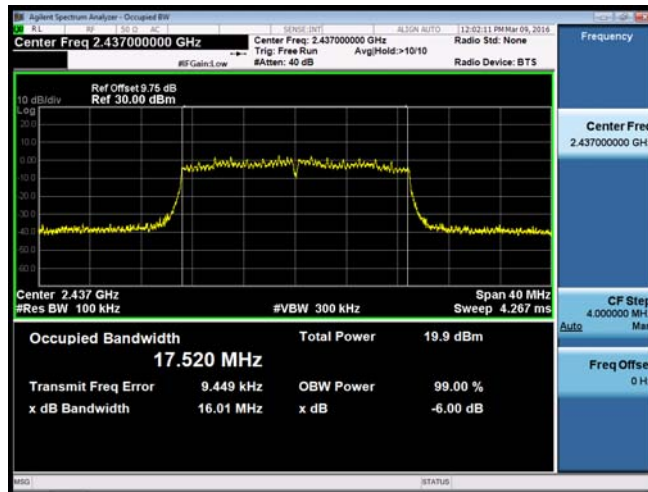

2462

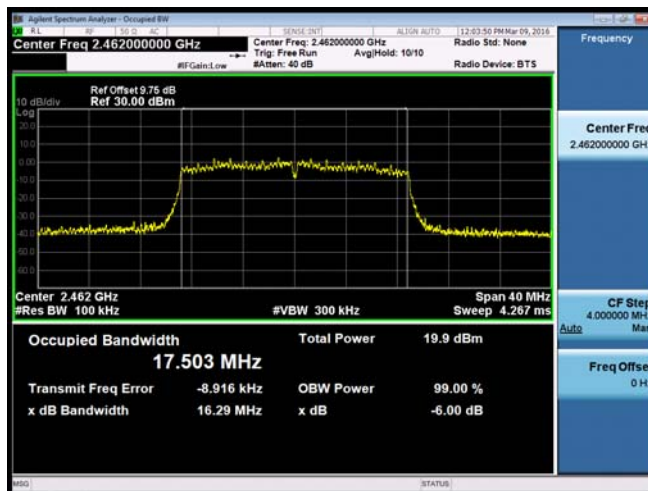

8 Maximum Power Density Measurement

8.1. Limit

For digitally modulated systems, the power spectral density conducted from the intentional radiator to the antenna shall not be greater than 8 dBm in any 3 kHz band during any time interval of continuous transmission.

8.2. Test Setup

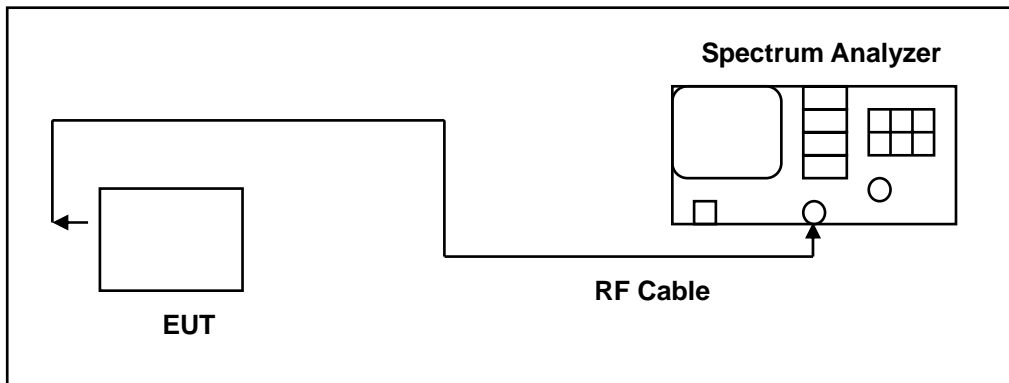

8.3. Test Instruments

Equipment	Manufacturer	Model Number	Serial Number	Cal. Date	Remark
Spectrum Analyzer	Agilent	N9020A	MY53420615	05/12/2015	(1)
Test Site	ATL	TE05	TE05	N.C.R.	----
RF cable	WOKEN	---	C.10-07-02	10/24/2015	(1)
RF cable	WOKEN	---	C.10-07-03	10/24/2015	(1)
Temporary antenna connector	---	---	A01-224	05/24/2015	(1)

Remark: (1) Calibration period 1 year. (2) Calibration period 2 years.

NOTE: N.C.R. = No Calibration Request.

All the RF cables apply to 9 KHz to 40GHz. The temporary antenna connector is soldered on the PCB board in order to perform conducted tests and this temporary antenna connector is listed in the equipment list.

8.4. Test Procedure

The EUT tested to DTS test procedure of KDB558074D01 for compliance to FCC 47CFR 15.247 requirements.

1. Set analyzer center frequency to DTS channel center frequency.
2. Set the span to 1.5 times the DTS bandwidth.
3. Set the RBW to: $3 \text{ kHz} \leq \text{RBW} \leq 100 \text{ kHz}$.
4. Set the VBW $\geq 3 \times \text{RBW}$.
5. Detector = peak.
6. Sweep time = auto couple.



7. Trace mode = max hold.
8. Allow trace to fully stabilize.
9. Use the peak marker function to determine the maximum amplitude level within the RBW.
10. If measured value exceeds limit, reduce RBW (no less than 3 kHz) and repeat.

8.5. Test Result

Model Number	recSMART		
Test Item	Maximum Power Density		
Test Mode	Mode 2: IEEE 802.11b link mode Mode 3: IEEE 802.11g link mode Mode 4: IEEE 802.11n 2.4GHz 20MHz link mode		
Date of Test	2016/03/09	Test Site	TE05
Test Mode	Frequency (MHz)	Measurement (dBm/10KHz)	Limit (dBm)
Mode 2	2412	-2.222	< 8
	2437	-2.347	< 8
	2462	-1.267	< 8
Mode 3	2412	-6.398	< 8
	2437	-5.012	< 8
	2462	-5.347	< 8
Mode 4	2412	-7.569	< 8
	2437	-7.083	< 8
	2462	-7.072	< 8



8.6. Test Graphs

Mode 2: IEEE 802.11b link mode

2412

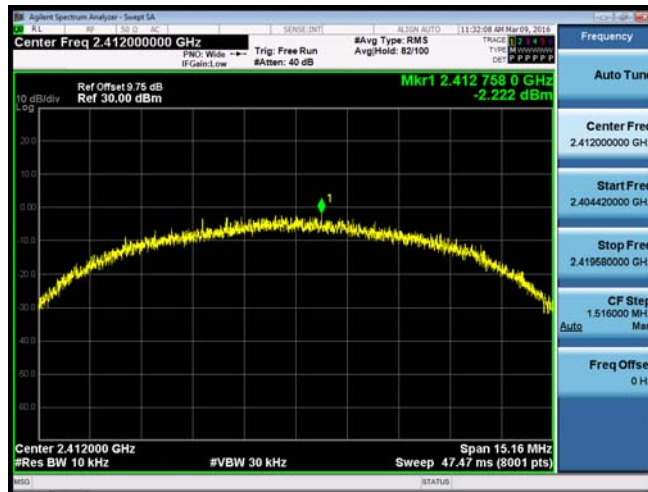

2437



2462

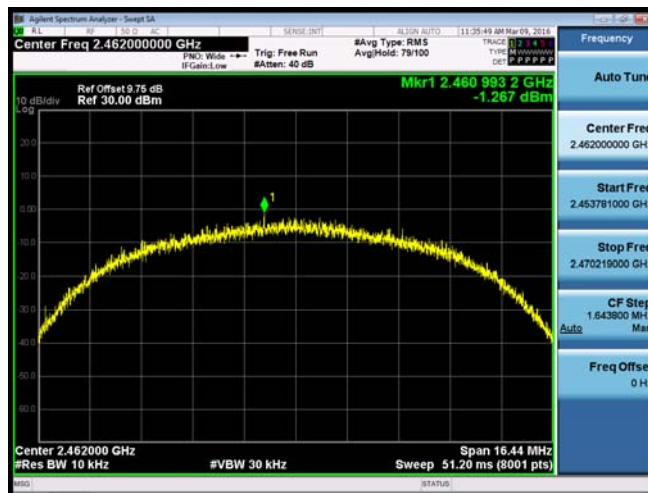



Mode 3: IEEE 802.11g link mode

2412

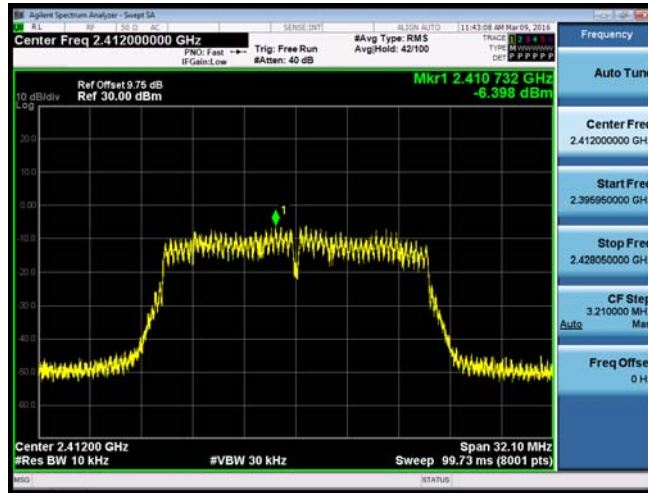

2437

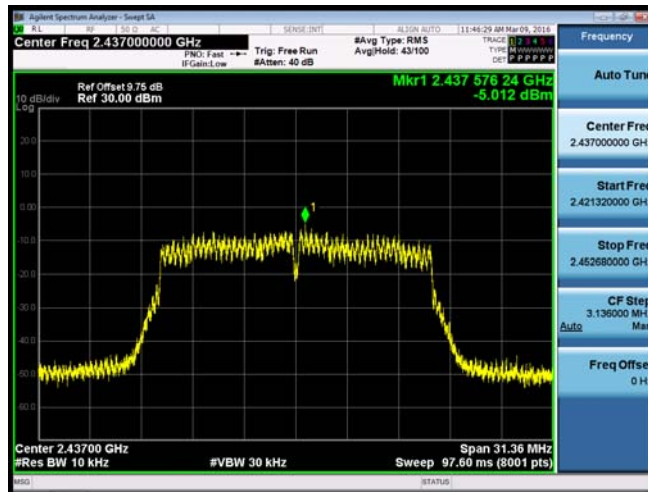

2462

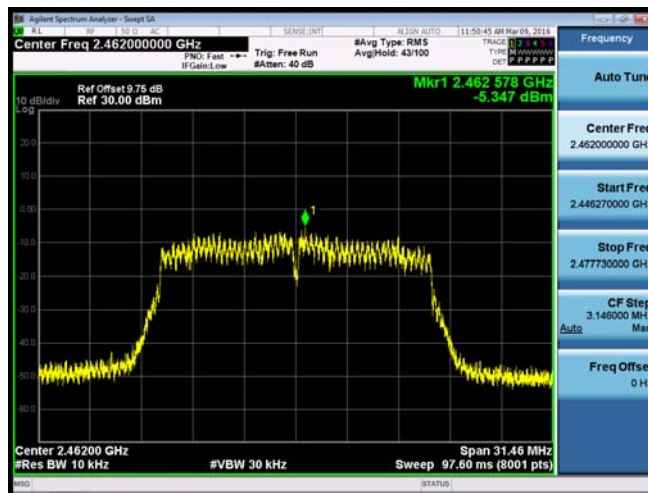



Mode 4: IEEE 802.11n 2.4GHz 20MHz link mode

2412



2437

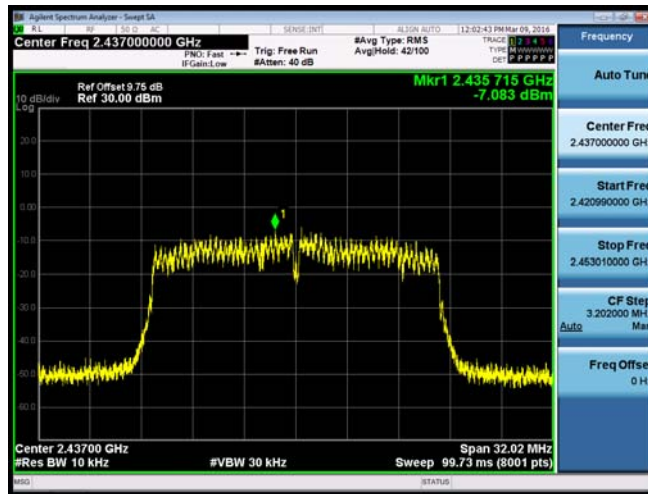

2462

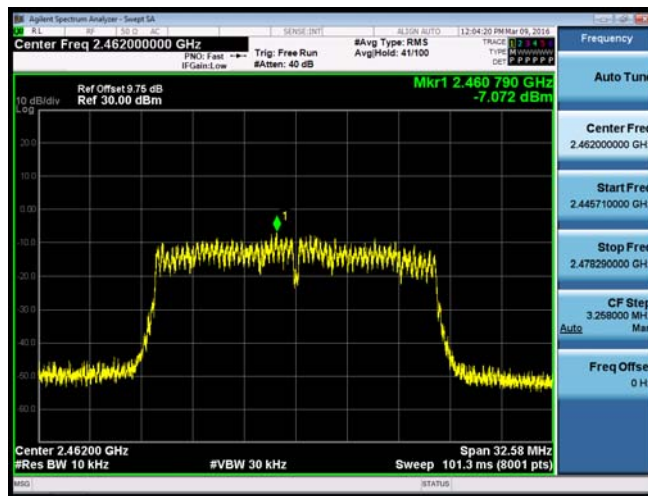

9 Out of Band Conducted Emissions Measurement

9.1. Limit

In any 100 kHz bandwidth outside the frequency band in which the spread spectrum or digitally modulated intentional radiator is operating, the radio frequency power that is produced by the intentional radiator shall be at least 20 dB below that in the 100 kHz bandwidth within the band that contains the highest level of the desired power

9.2. Test Setup

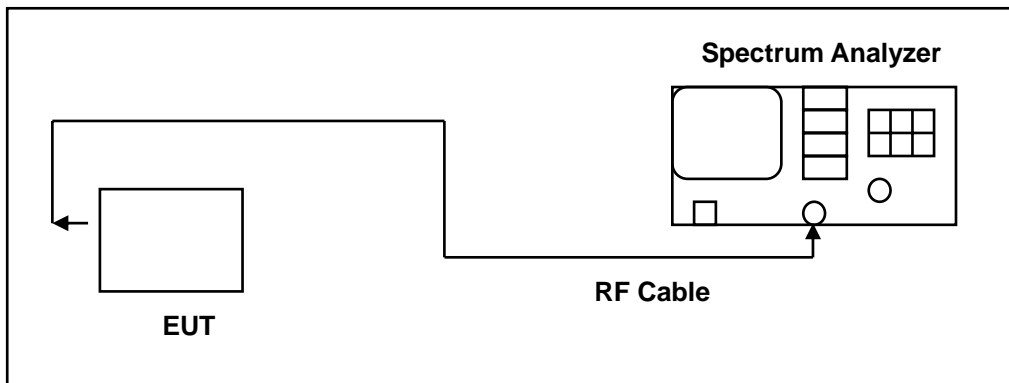

9.3. Test Instruments

Equipment	Manufacturer	Model Number	Serial Number	Cal. Date	Remark
Spectrum Analyzer	Agilent	N9020A	MY53420615	05/12/2015	(1)
Test Site	ATL	TE05	TE05	N.C.R.	----
RF cable	WOKEN	---	C.10-07-02	10/24/2015	(1)
RF cable	WOKEN	---	C.10-07-03	10/24/2015	(1)
Temporary antenna connector	---	---	A01-224	05/24/2015	(1)

Remark: (1) Calibration period 1 year. (2) Calibration period 2 years.

NOTE: N.C.R. = No Calibration Request.

All the RF cables apply to 9 KHz to 40GHz. The temporary antenna connector is soldered on the PCB board in order to perform conducted tests and this temporary antenna connector is listed in the equipment list.

9.4. Test Procedure

In any 100 kHz bandwidth outside the EUT pass band, the RF power produced by the modulation products of the spreading sequence, the information sequence, and the carrier frequency shall be at least 20 dB below that of the maximum in-band 100 kHz emission, antenna output of the EUT was coupled directly to spectrum analyzer; if an external attenuator and/or cable was used, these losses are compensated for with the analyzer OFFSET function.

All other types of emissions from the EUT shall meet the general limits for radiated frequencies outside the pass band.

The test was performed at 3 channels.



9.5. Test Graphs

1. We tested from 9KHz to 25GHz, recorded from 30MHz to 25GHz.

Reference level and Out of Band Conducted Emissions

Mode 2: IEEE 802.11b link mode	
2412	

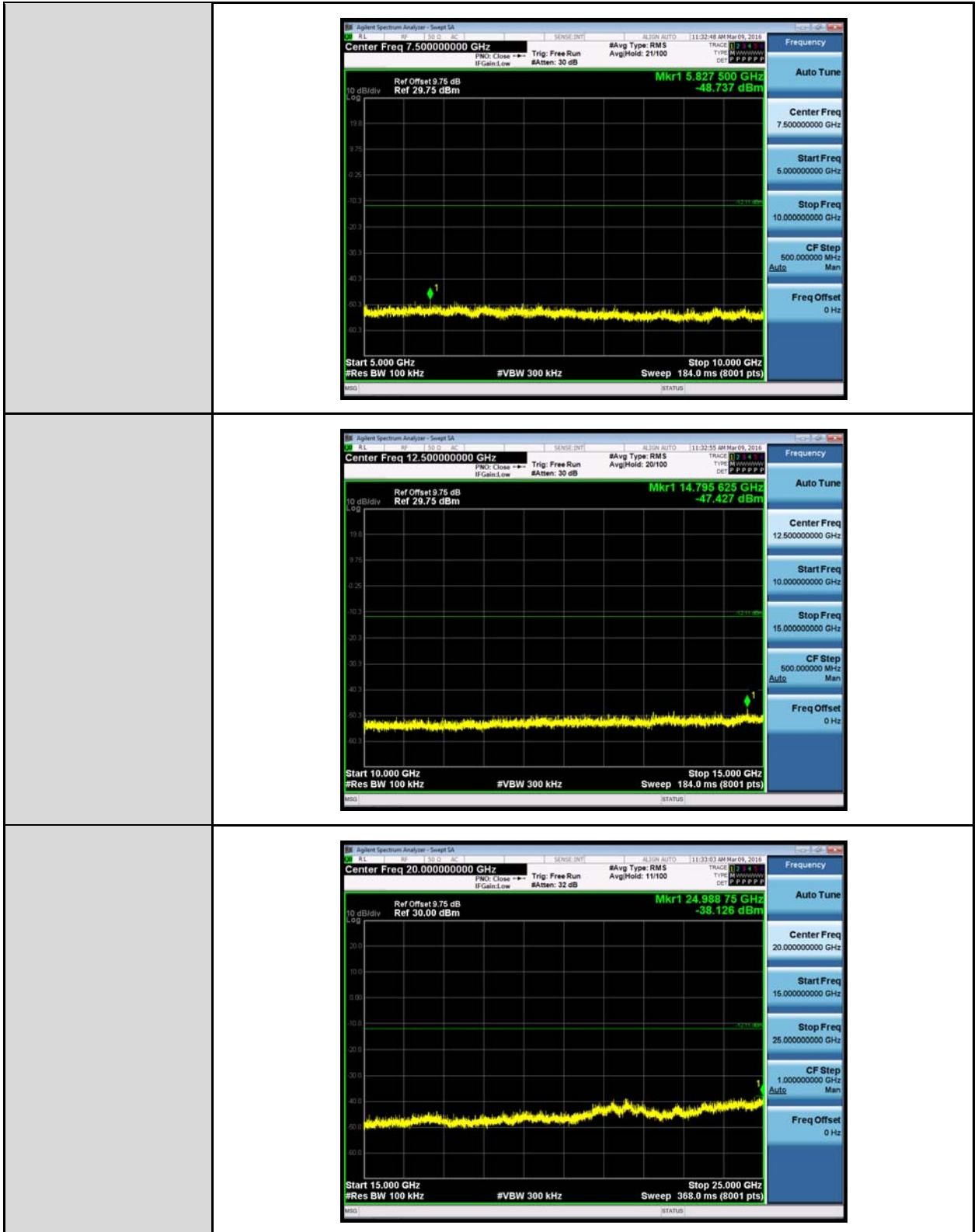



2437

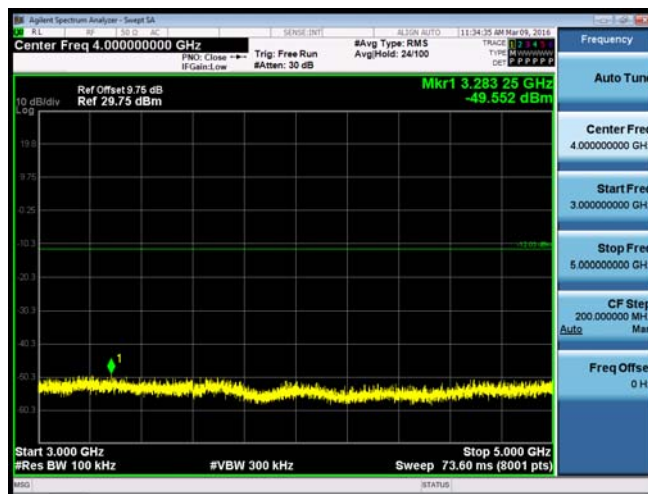
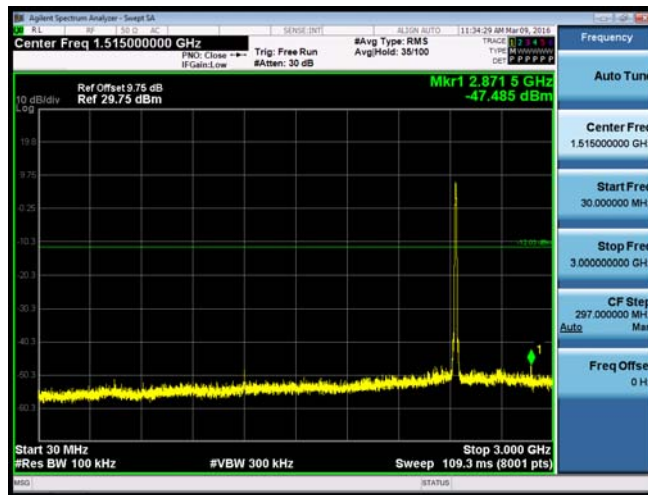
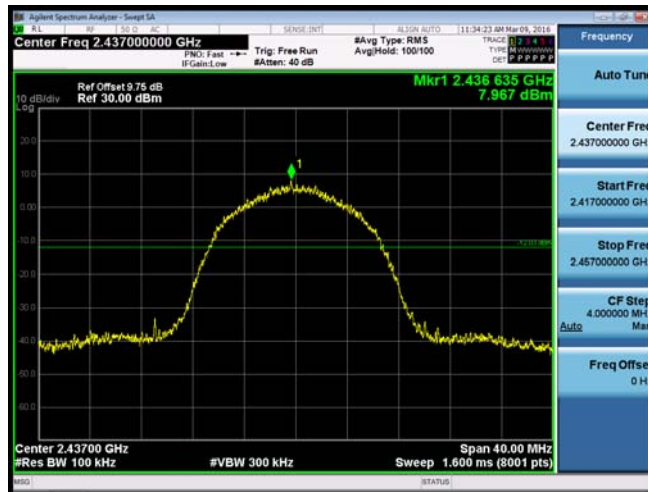

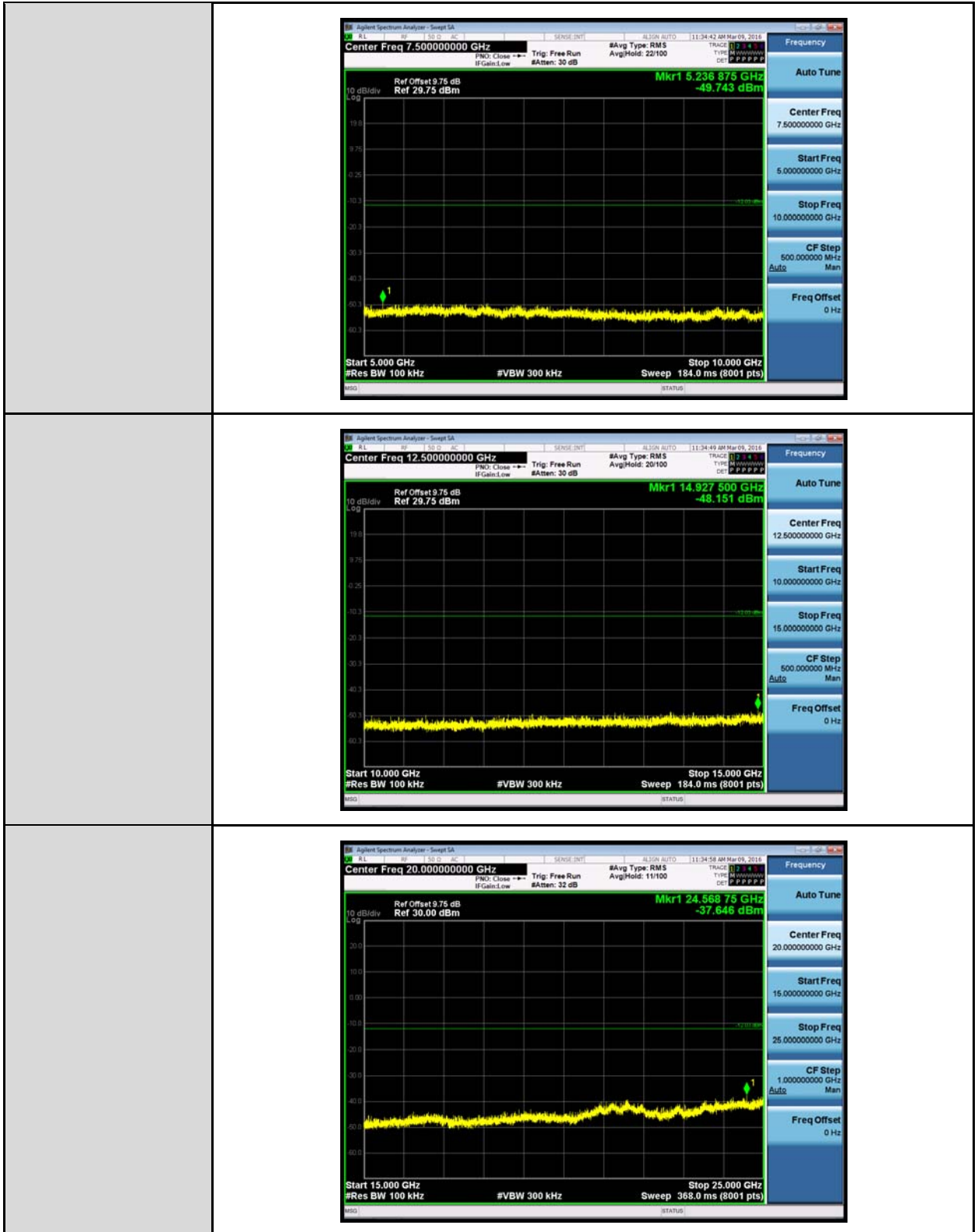



2462

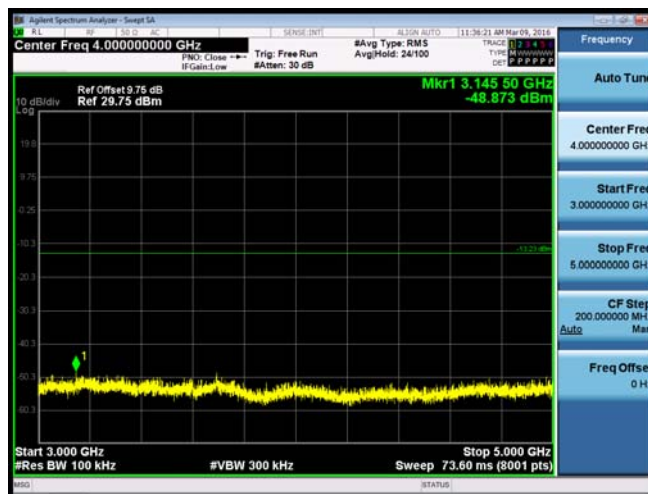
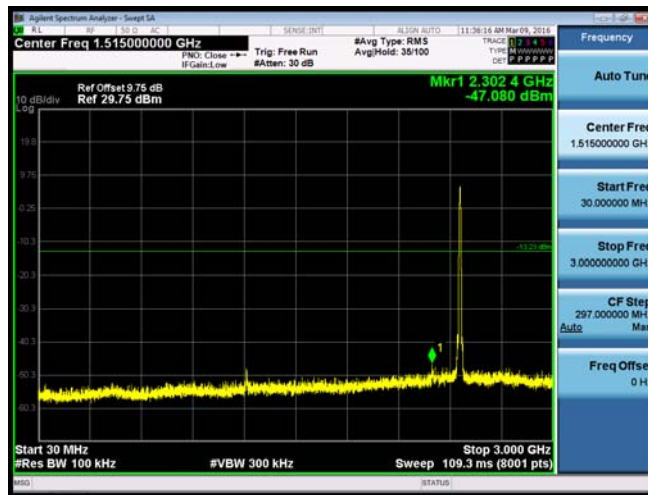
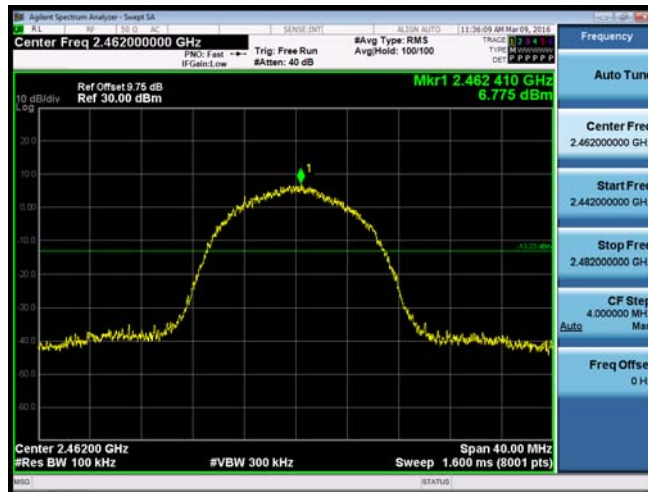

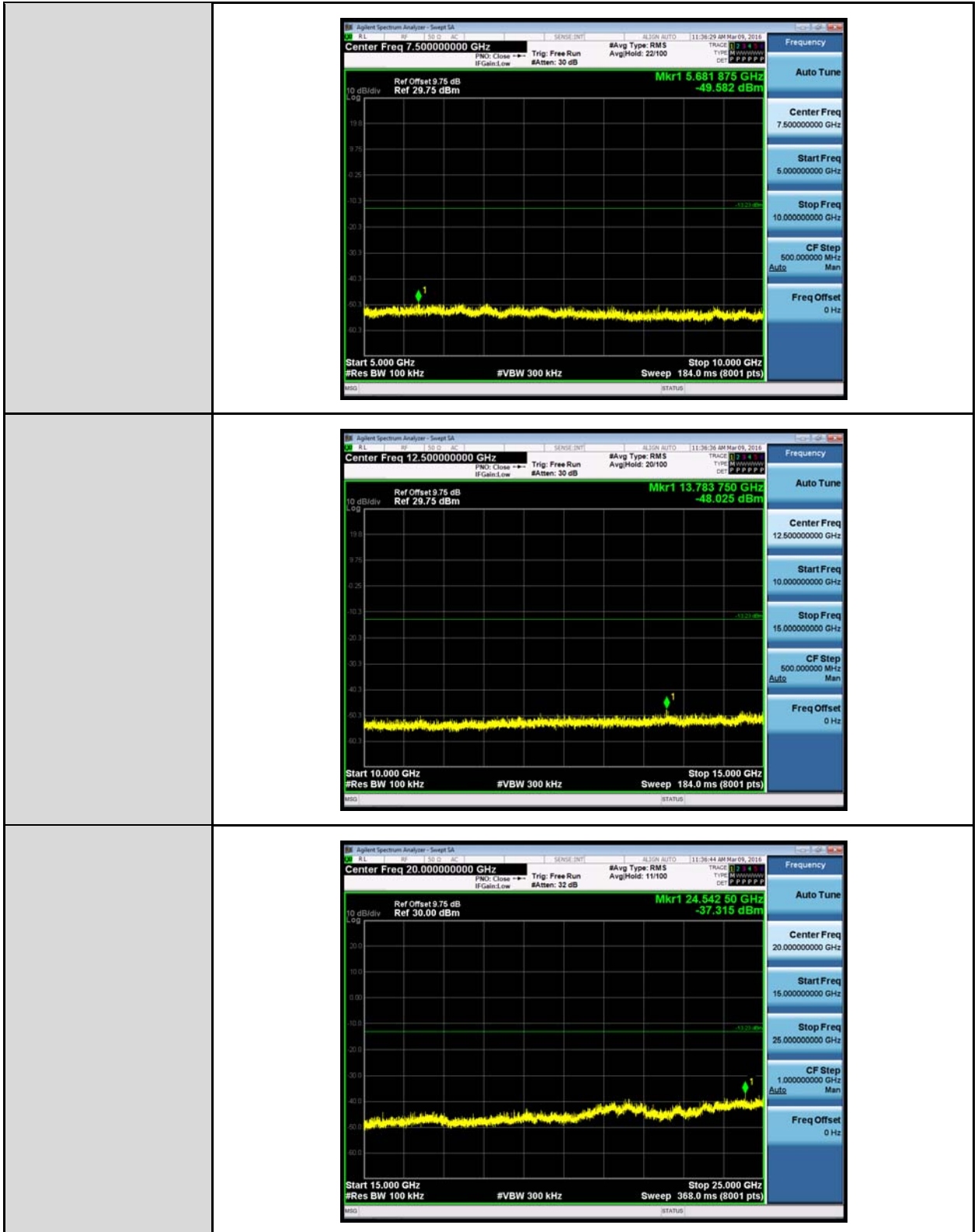



Mode 3: IEEE 802.11g link mode

2412

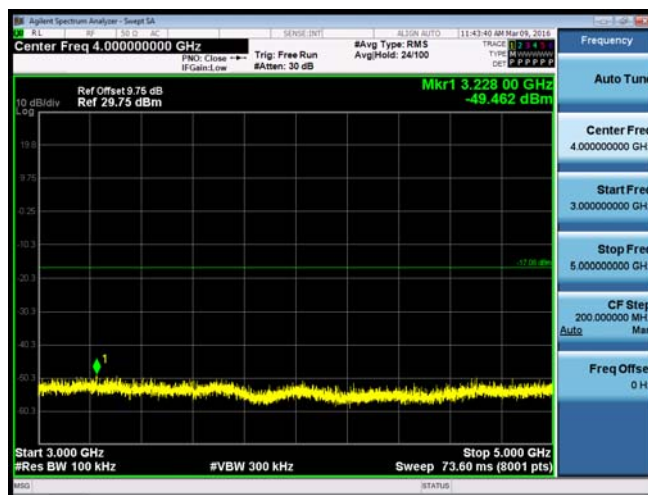
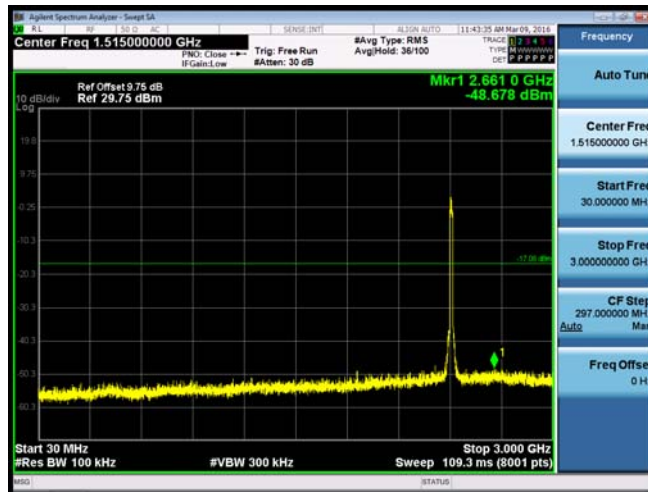

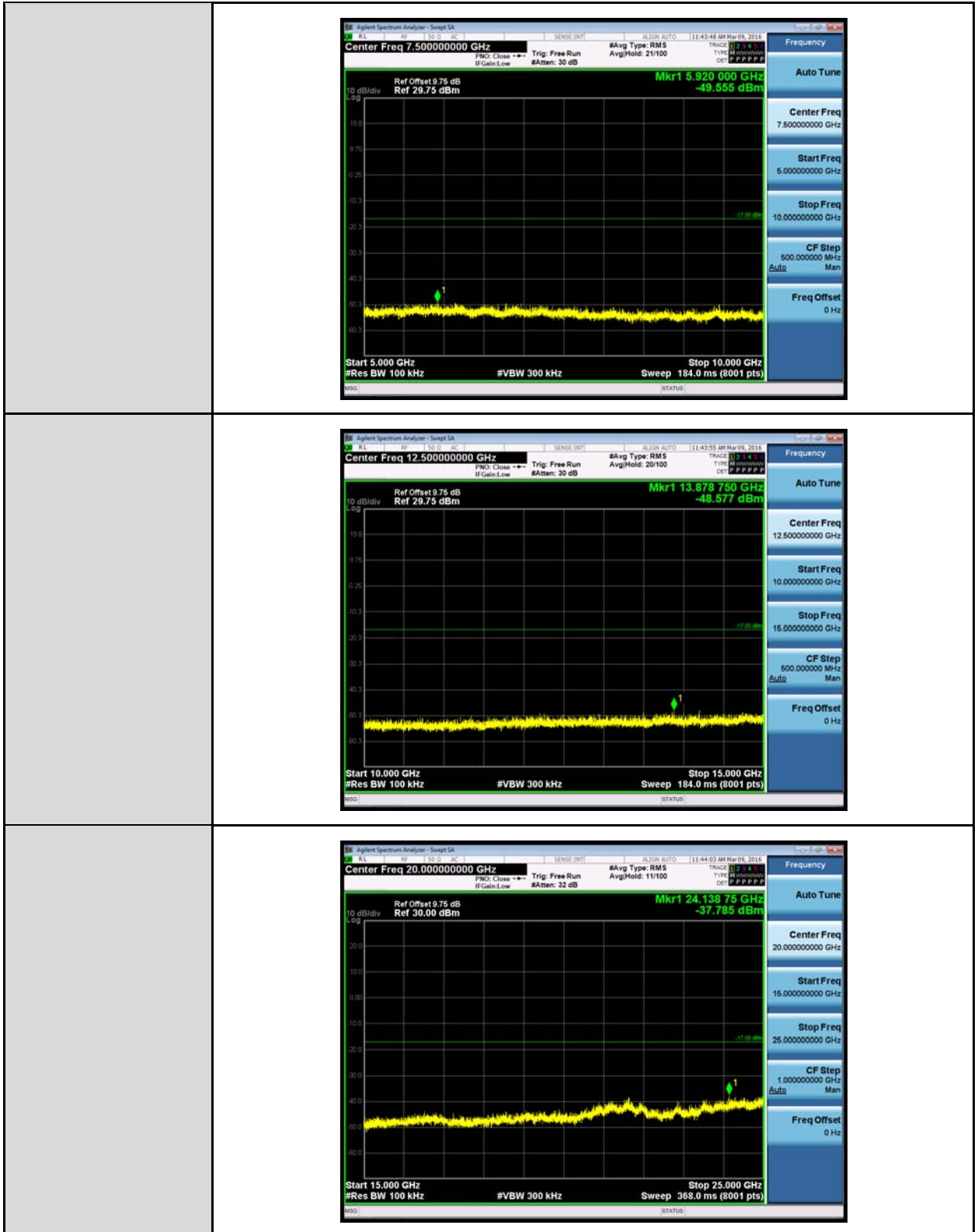



2437

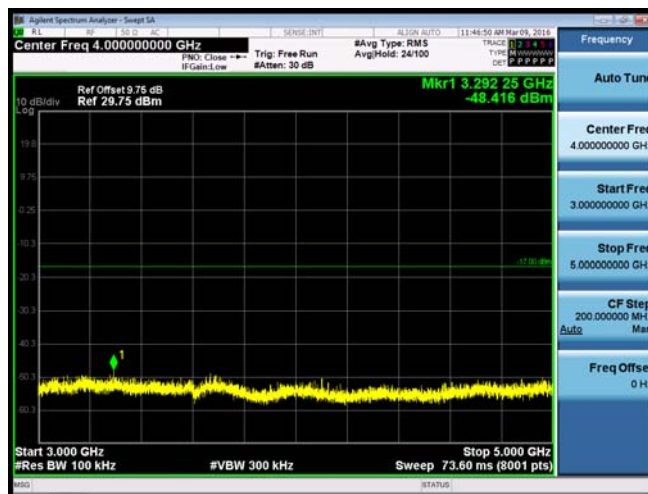
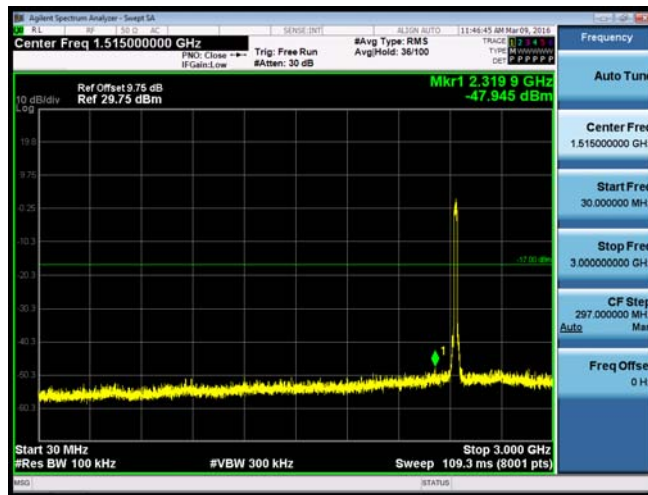
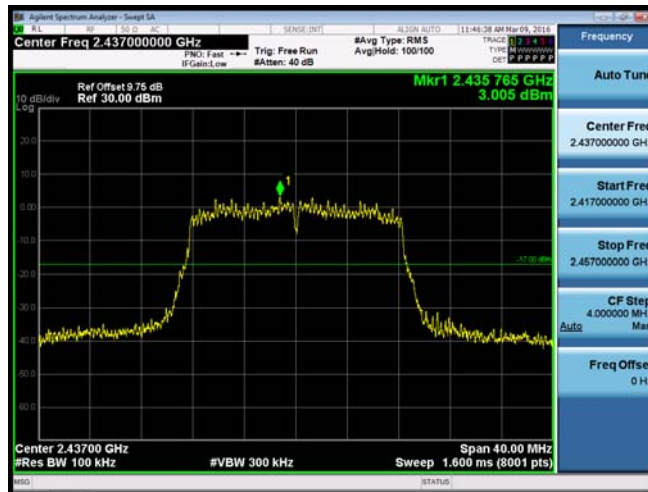

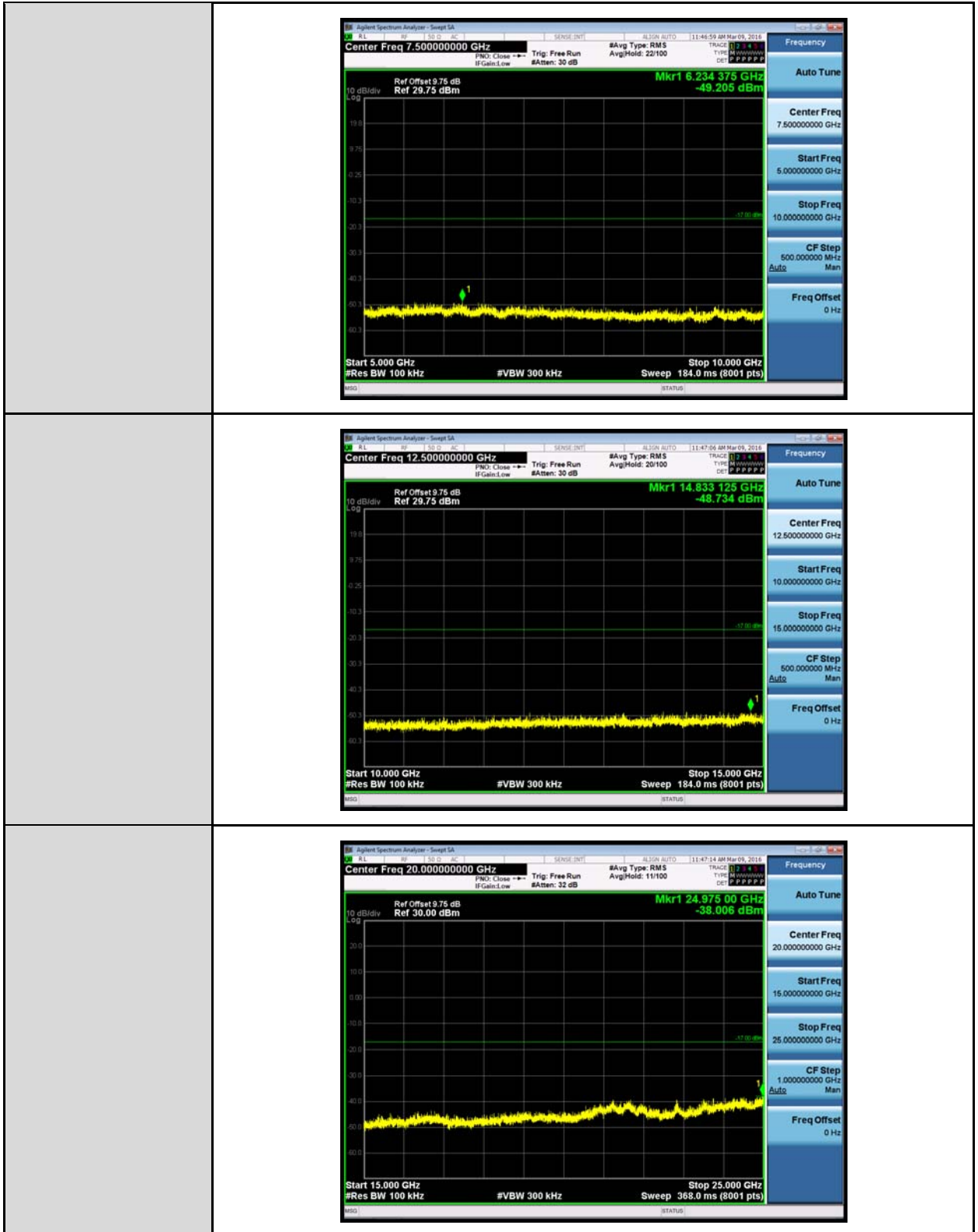



2462

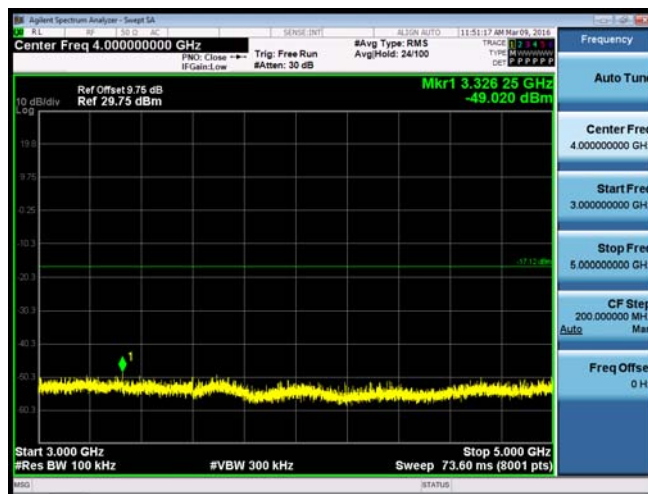
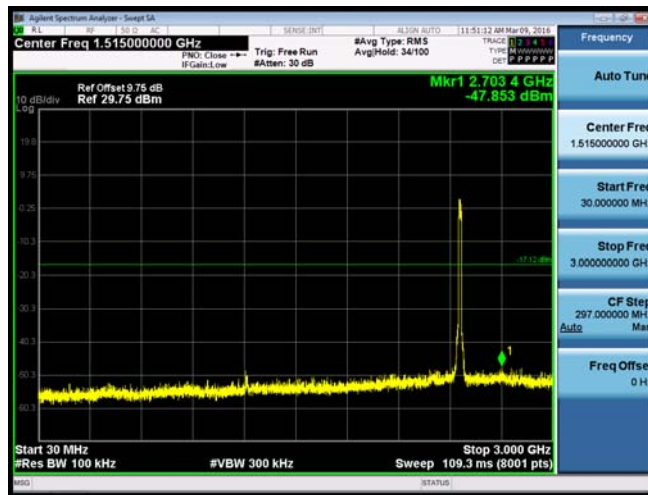

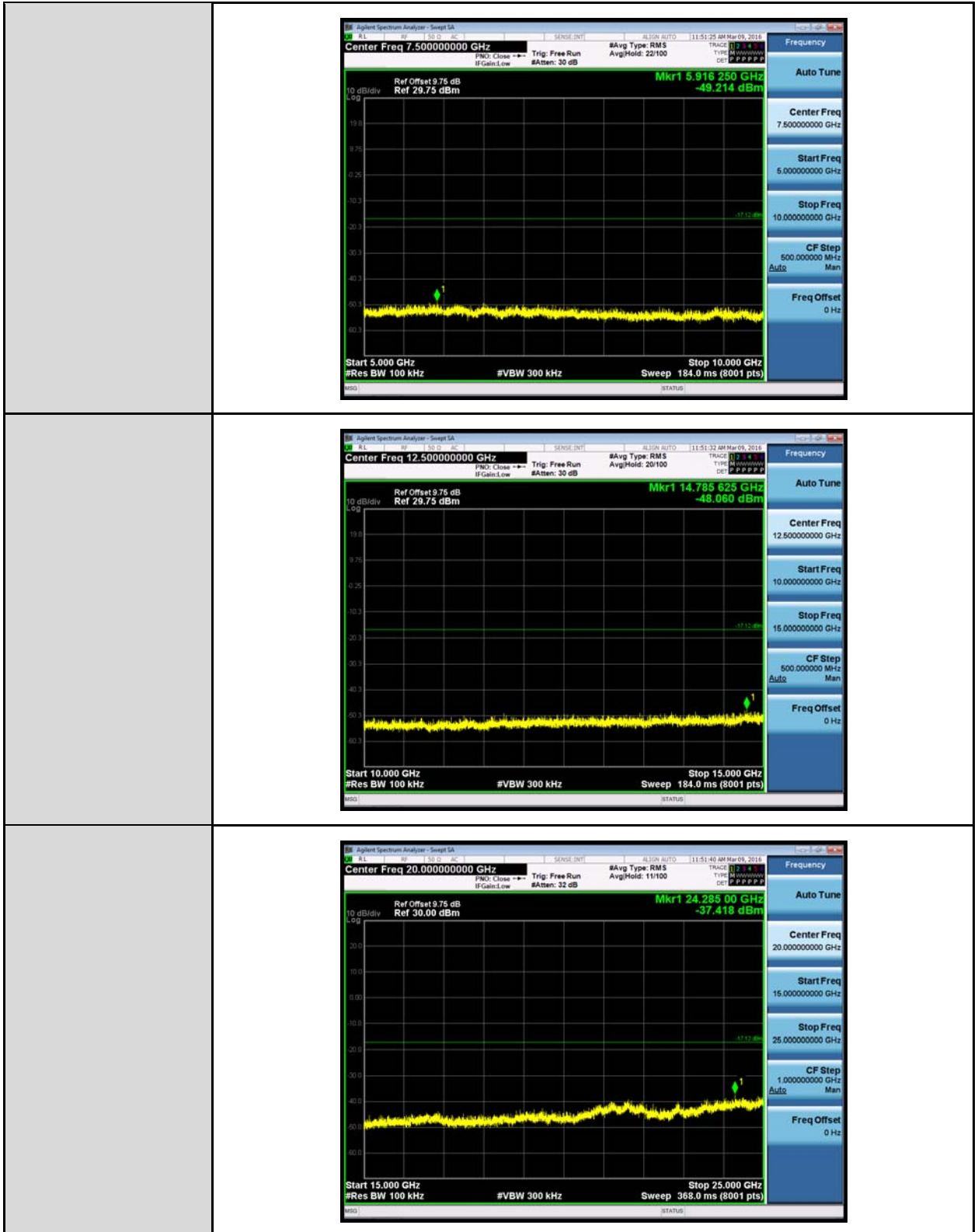



Mode 4: IEEE 802.11n 2.4GHz 20MHz link mode

2412

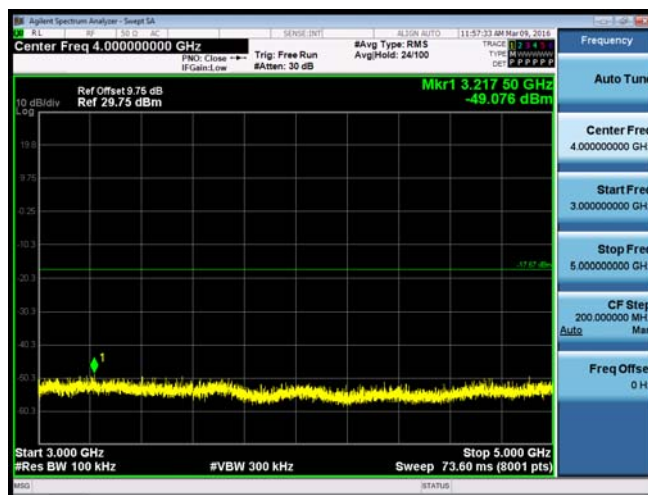
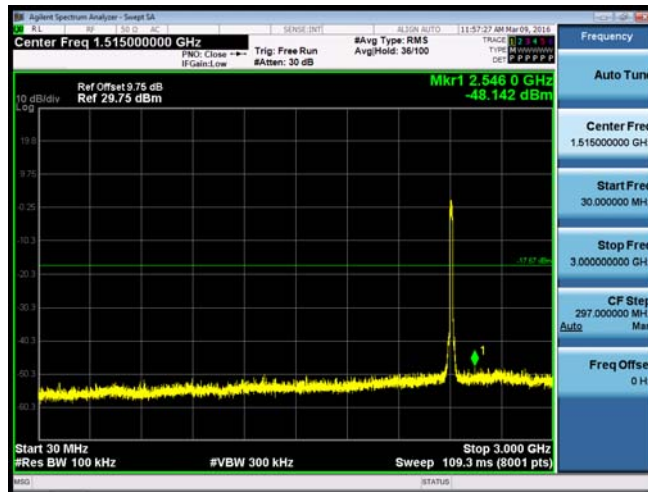
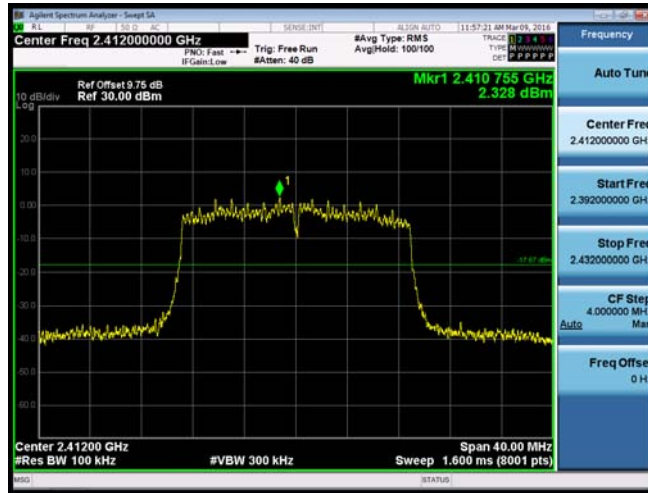

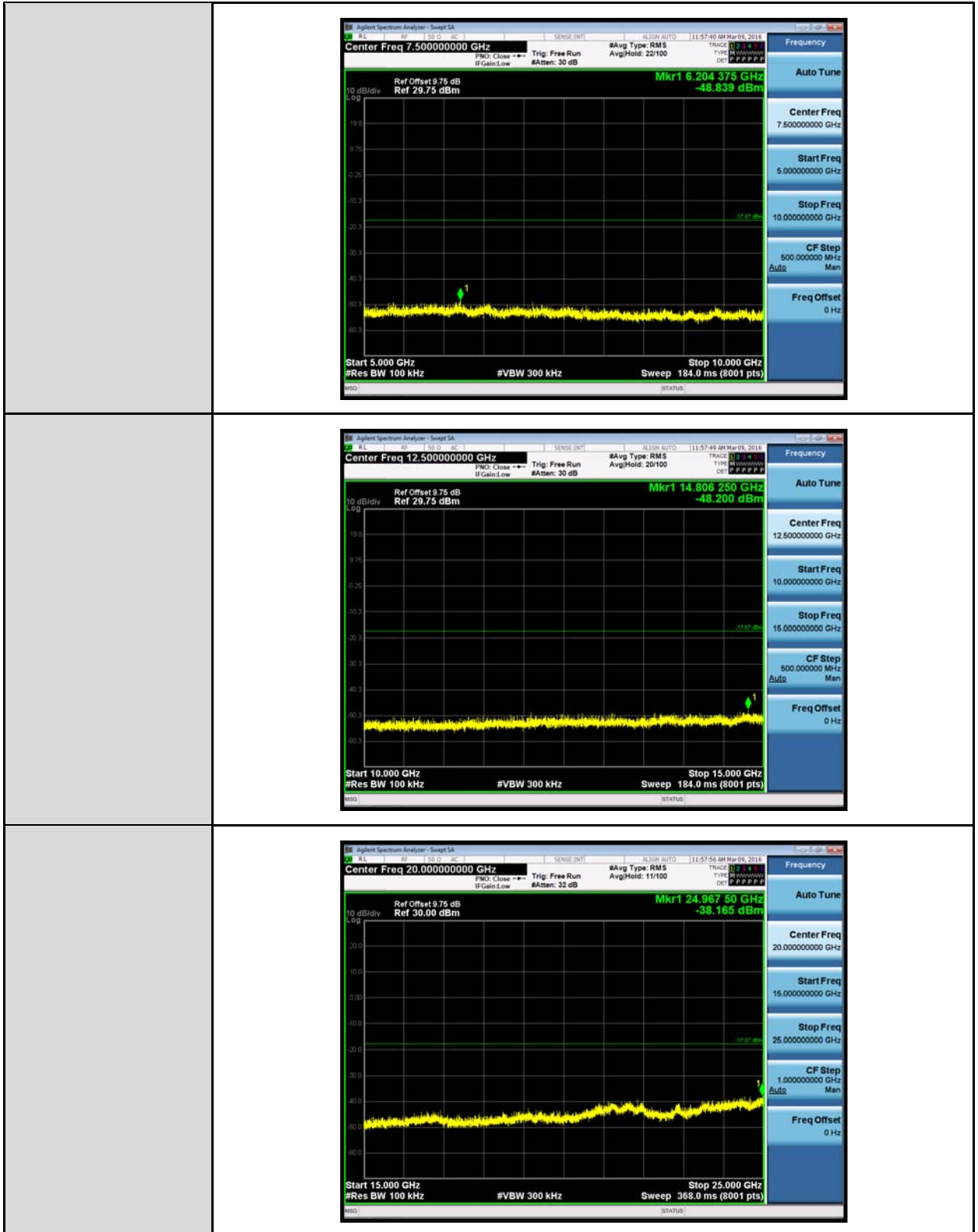



2437

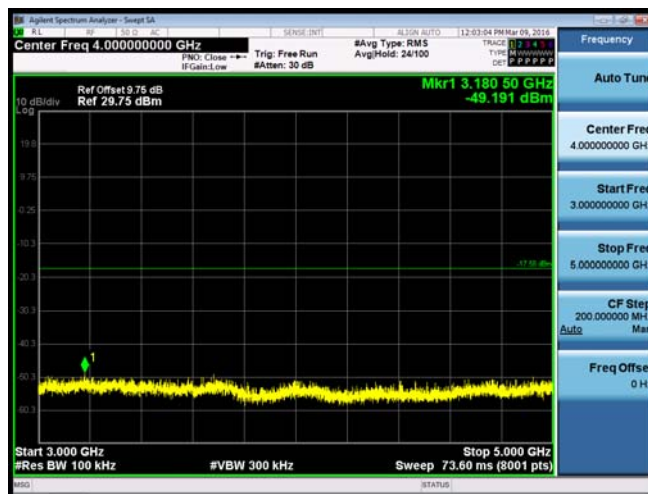
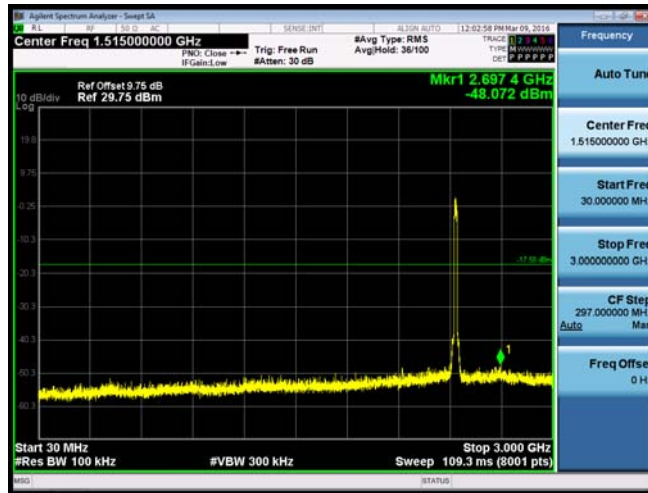
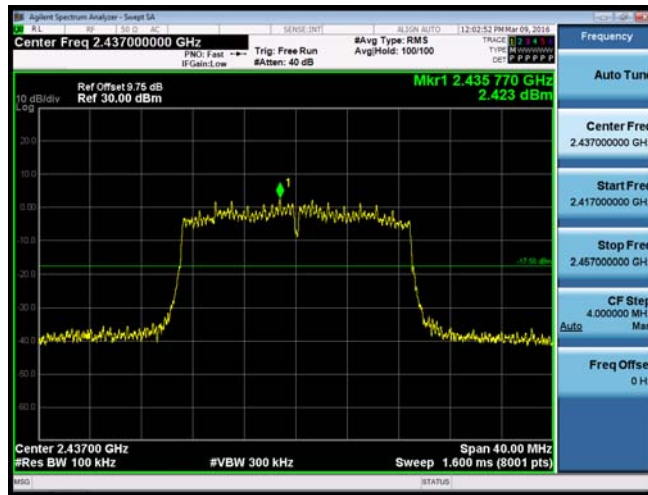

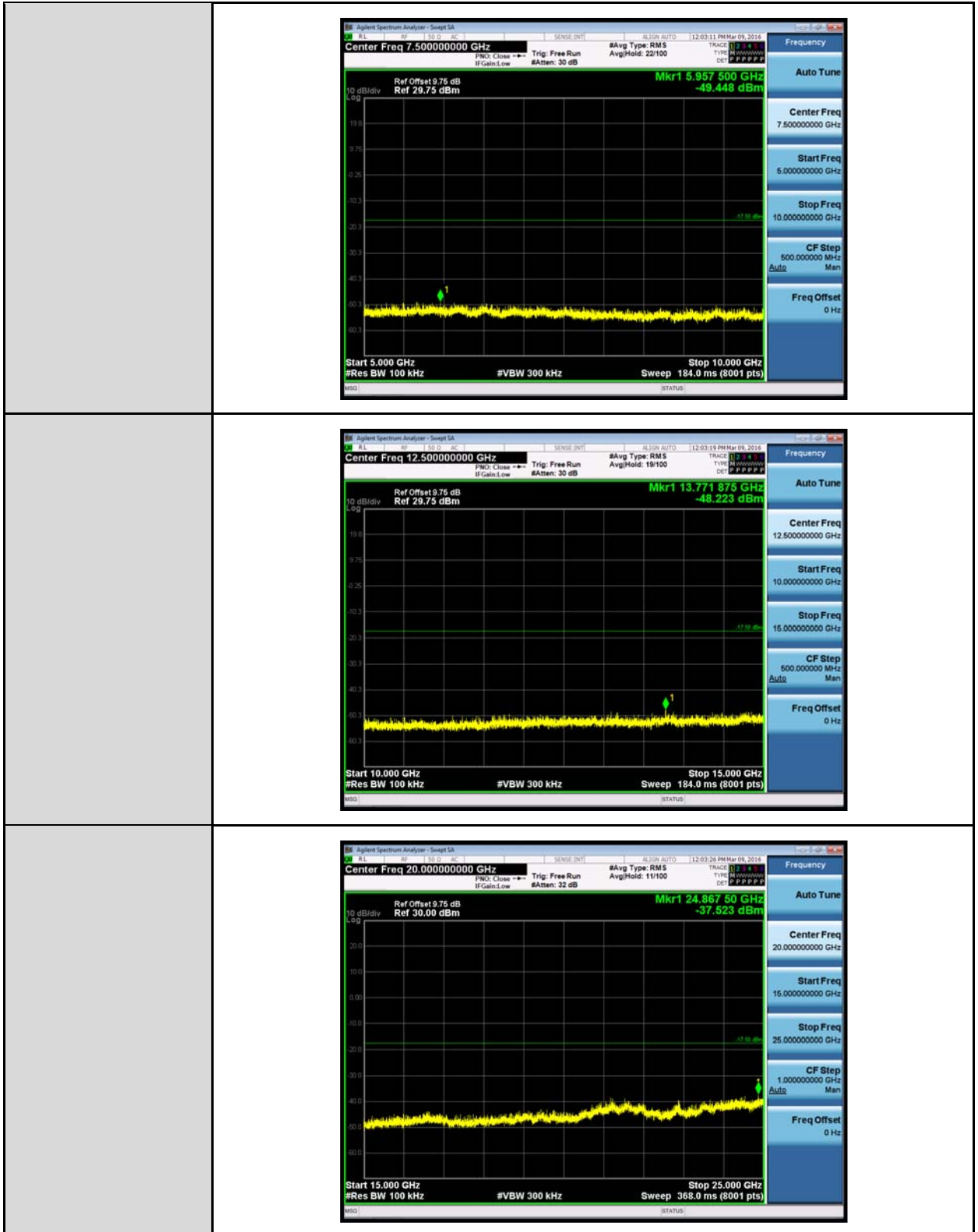



2462

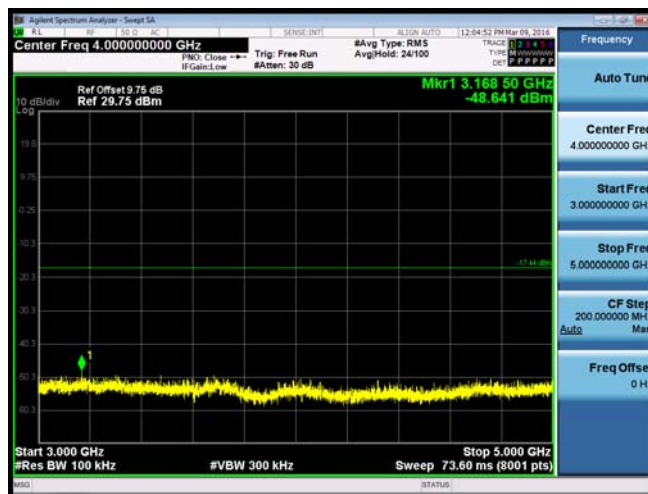
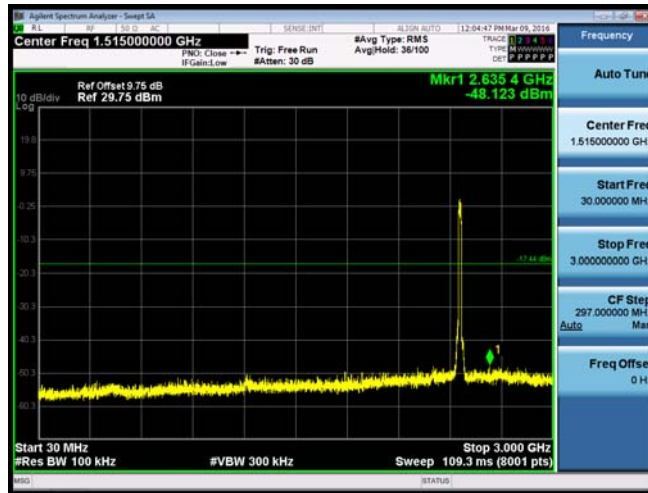

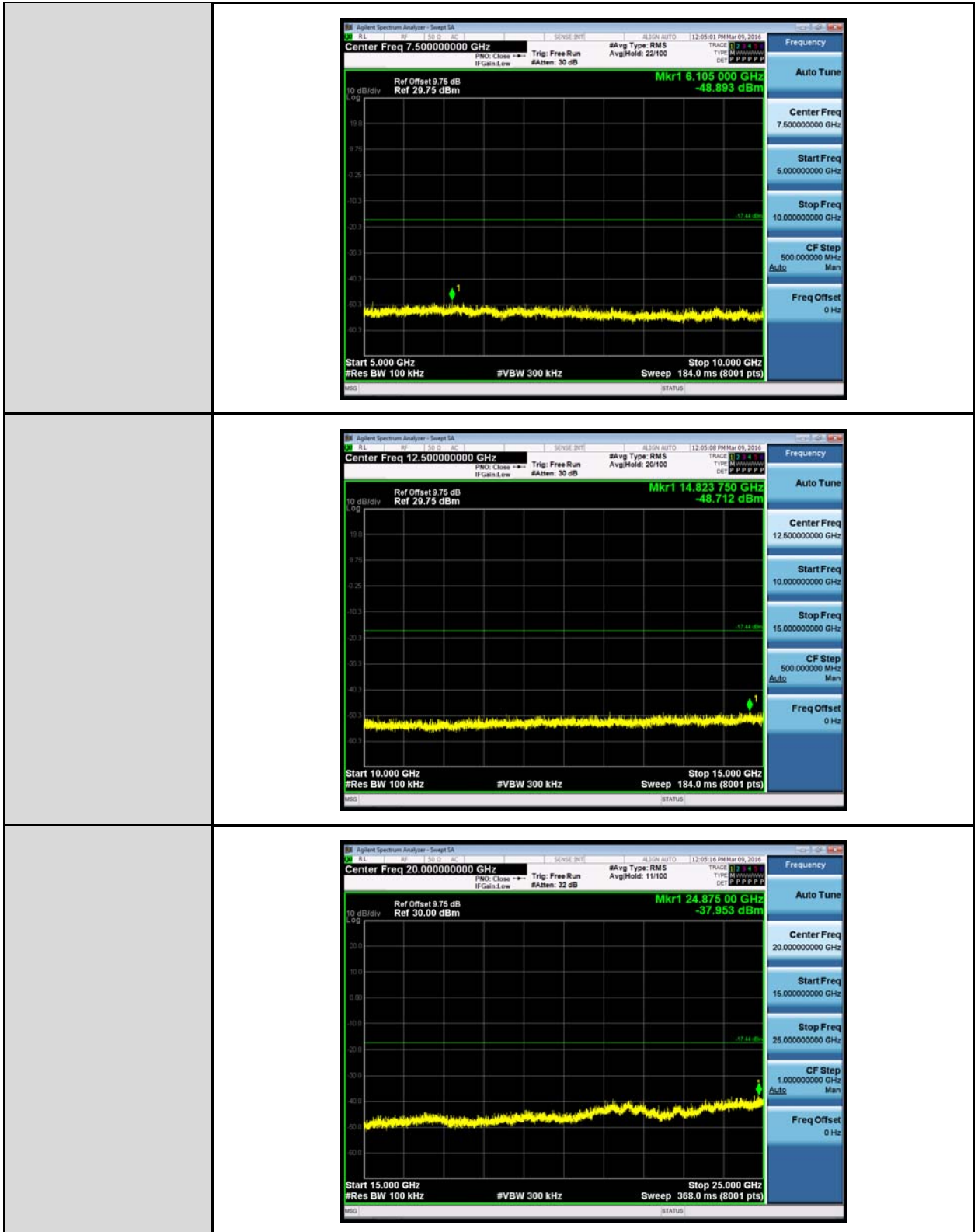



Conducted Band Edge

Mode 2: IEEE 802.11b link mode

2412

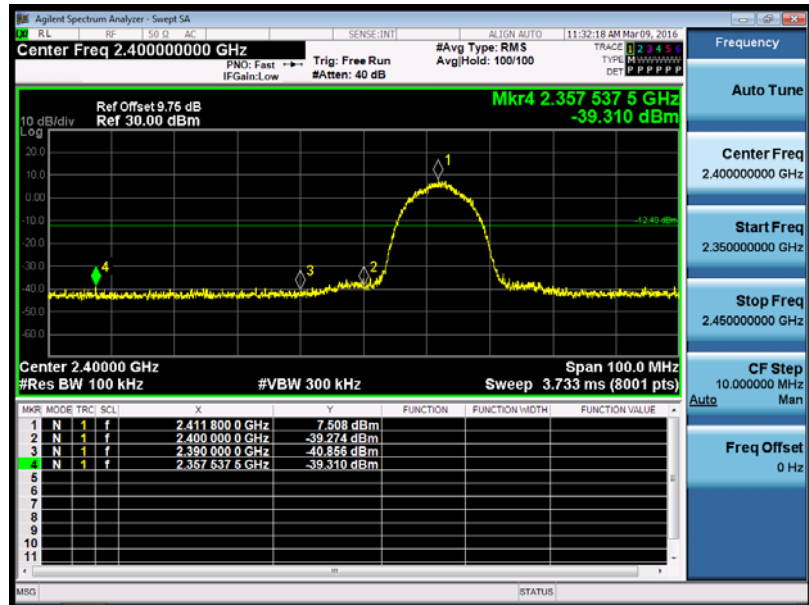

2462

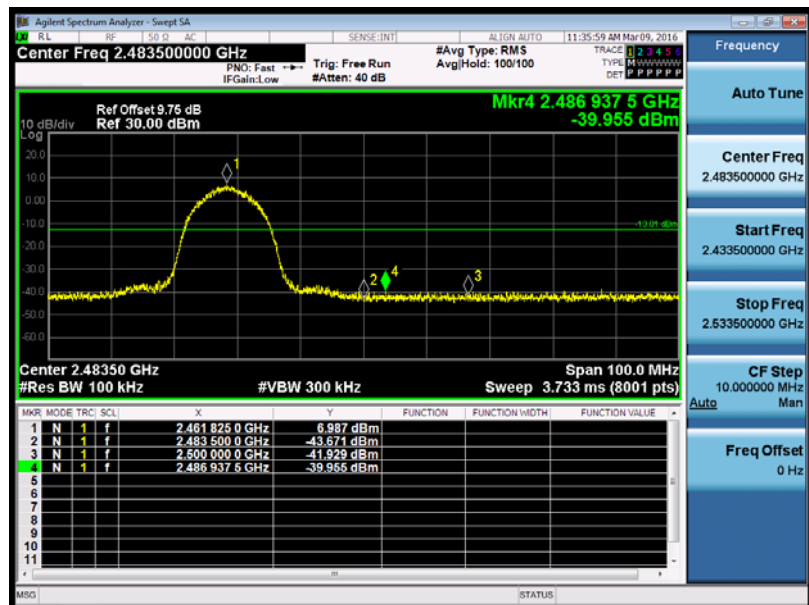



Mode 3: IEEE 802.11g link mode

2412

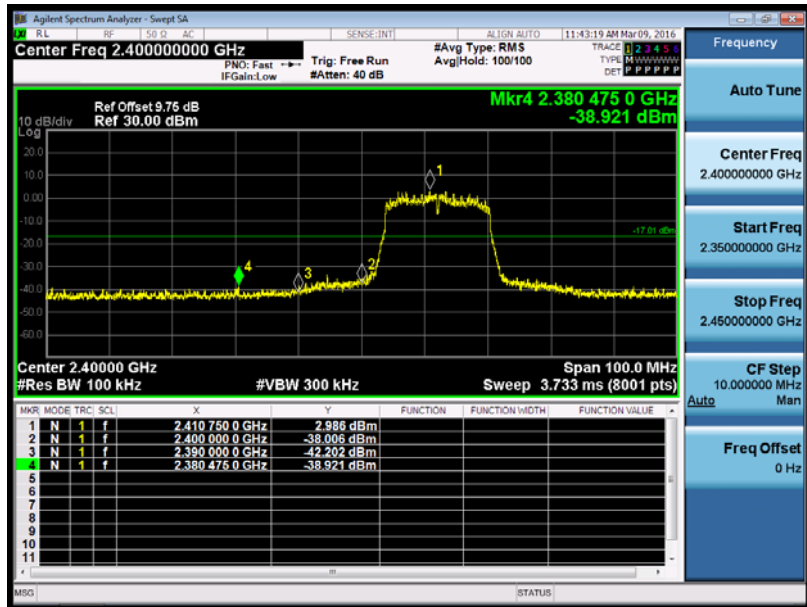

2462

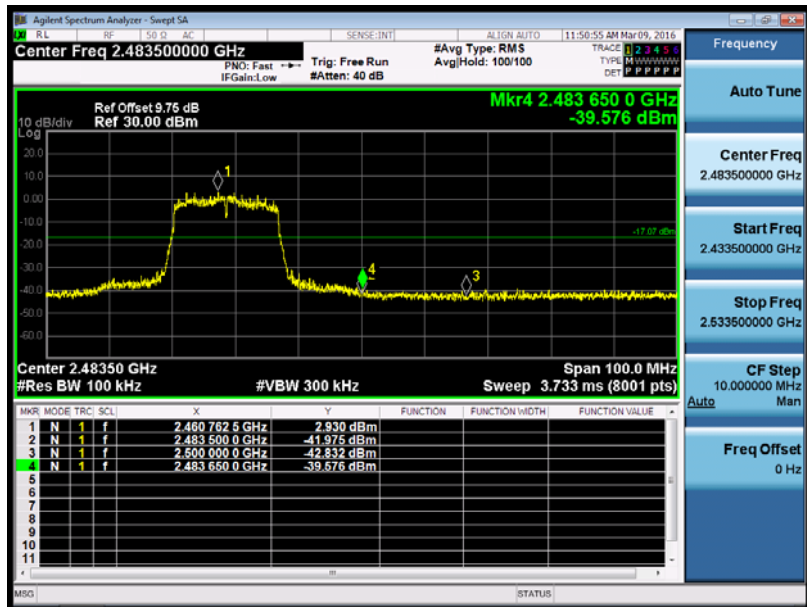



Mode 4: IEEE 802.11n 2.4GHz 20MHz link mode

2412

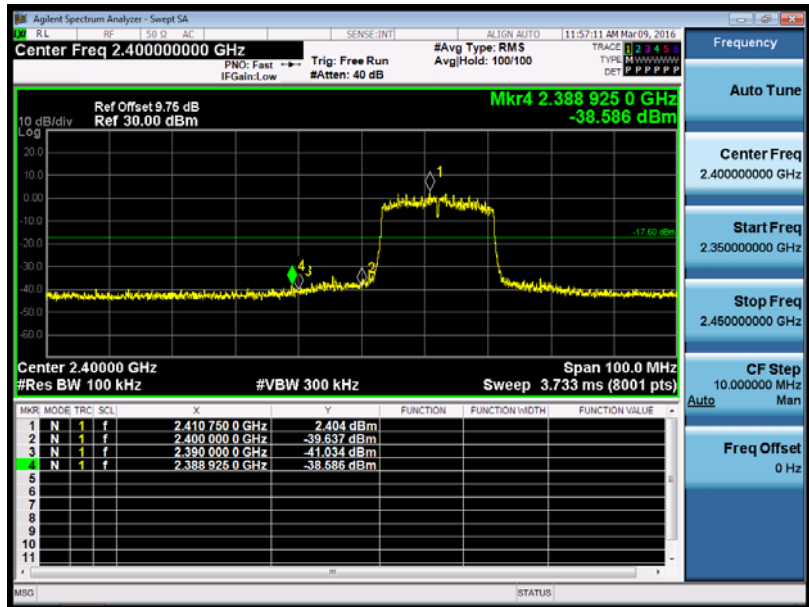

2462

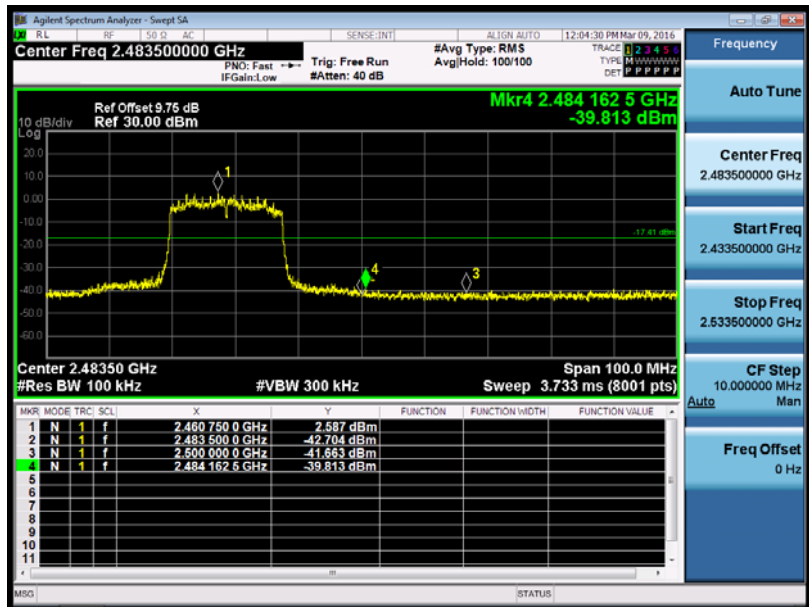

10 Band Edges Measurement

10.1.Limit

In any 100 kHz bandwidth outside the intentional radiation frequency band, the radio frequency power shall be at least 20 dB below the highest level of the radiated power. In addition, radiated emissions which fall in the restricted bands must also comply with the radiated emission limits.

10.2.Test Setup

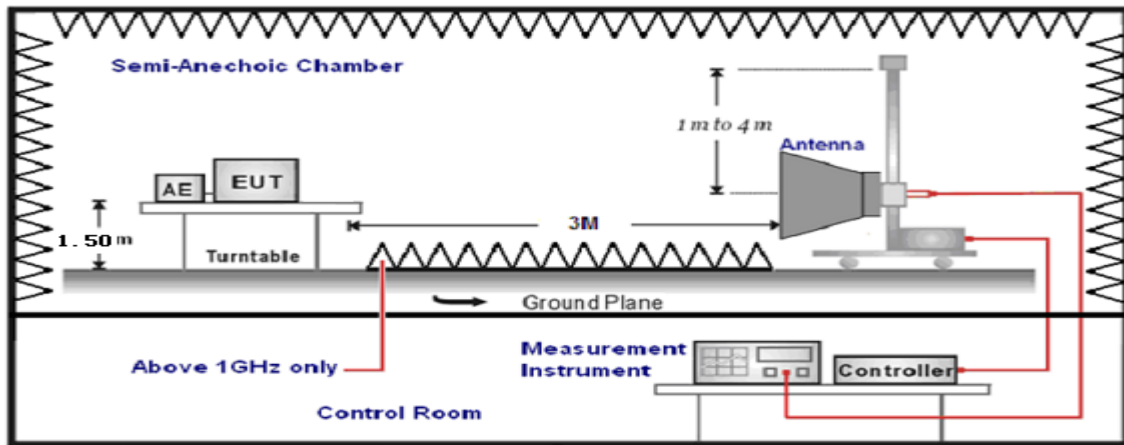

10.3.Test Instruments

3 Meter Chamber					
Model No.	Equipment	Manufacturer	Serial Number	Cal. Date	Remark
9X6X6	3m Semi-anechoic chamber	Albatross Projects	SB3450/01	Oct.12, 2015	(1)
HF907	Horn Antenna	Rohde & Schwarz	100309	May.15,2015	(1)
SCU26	Pre Amplifier	Rohde & Schwarz	10020	May.15.2015	(1)
SCU40	Pre Amplifier	Rohde & Schwarz	10015	May.15.2015	(1)
ESU40	Test Receiver	Rohde & Schwarz	100263	May.15.2015	(1)
---	RF cable	WOKEN	S02-1404-09-065	May.11.2015	(1)
---	RF cable	WOKEN	S02-1404-09-047	May.11.2015	(1)
---	RF cable	WOKEN	S02-1404-09-052	May.11.2015	(1)

Remark: (1) Calibration period 1 year. (2) Calibration period 2 years.

NOTE: N.C.R. = No Calibration Request.

All the RF cables apply to 9 KHz to 40GHz. The temporary antenna connector is soldered on the PCB board in order to perform conducted tests and this temporary antenna connector is listed in the equipment list.



10.4. Test Procedure

The EUT tested to DTS test procedure of KDB558074D01 for compliance to FCC 47CFR 15.247 requirements.

The emissions on the harmonics frequencies, the limits, and the margin of compliance are presented. These tests were made when the transmitter was in full radiated power. The additional test was performed to show compliance with the requirement at the band-edge frequency 2483.5 MHz and up to 2500 MHz and at 2390.0 MHz.

The transmitter was configured with the worst case antenna and setup to transmit at the highest channel. Then the field strength was measured at 2483.5 MHz.

The transmitter was then configured with the worst case antenna and setup to transmit at the lowest channel. Then the field strength was measured at 2390.0 MHz. These tests were performed at 4 different bit rates.

For measurements above 1 GHz the resolution bandwidth is set to 1 MHz, and then the video bandwidth is set to 1 MHz for peak measurements and 10 Hz for average measurements when Duty cycle $>0.98 / 1/T$ for average measurements when Duty cycle <0.98 .



10.5. Test Result

Mode 2: IEEE 802.11b Link Mode																															
2412/H	<p style="text-align: center;">FCC Electric Field Strength 2.4GHz Bandedge-PK</p>																														
2412/V	<p style="text-align: center;">FCC Electric Field Strength 2.4GHz Bandedge-PK</p>																														
	<table border="1"> <thead> <tr> <th>Frequency (MHz)</th> <th>Result (dBuV/m)</th> <th>Limit (dBuV/m)</th> <th>Margin (dB)</th> <th>Antenna</th> <th>Remark</th> </tr> </thead> <tbody> <tr> <td>2390.4</td> <td>47.99</td> <td>74</td> <td>-26.01</td> <td>H</td> <td>Peak</td> </tr> <tr> <td>2390.4</td> <td>38.24</td> <td>54</td> <td>-15.76</td> <td>H</td> <td>Average</td> </tr> <tr> <td>2390.1</td> <td>46.82</td> <td>74</td> <td>-27.18</td> <td>V</td> <td>Peak</td> </tr> <tr> <td>2390.1</td> <td>36.81</td> <td>54</td> <td>-17.19</td> <td>V</td> <td>Average</td> </tr> </tbody> </table>	Frequency (MHz)	Result (dBuV/m)	Limit (dBuV/m)	Margin (dB)	Antenna	Remark	2390.4	47.99	74	-26.01	H	Peak	2390.4	38.24	54	-15.76	H	Average	2390.1	46.82	74	-27.18	V	Peak	2390.1	36.81	54	-17.19	V	Average
Frequency (MHz)	Result (dBuV/m)	Limit (dBuV/m)	Margin (dB)	Antenna	Remark																										
2390.4	47.99	74	-26.01	H	Peak																										
2390.4	38.24	54	-15.76	H	Average																										
2390.1	46.82	74	-27.18	V	Peak																										
2390.1	36.81	54	-17.19	V	Average																										



Mode 2: IEEE 802.11b Link Mode

2462/H

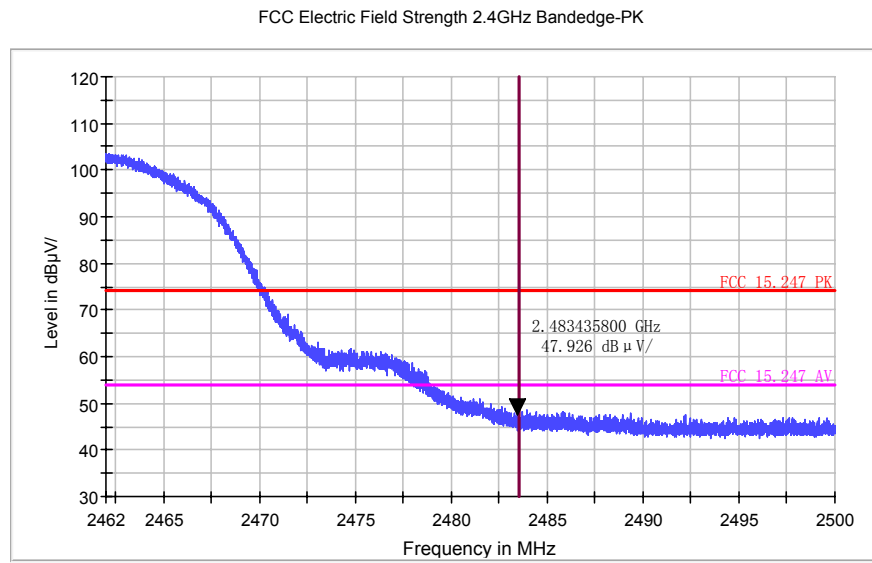

2462/V

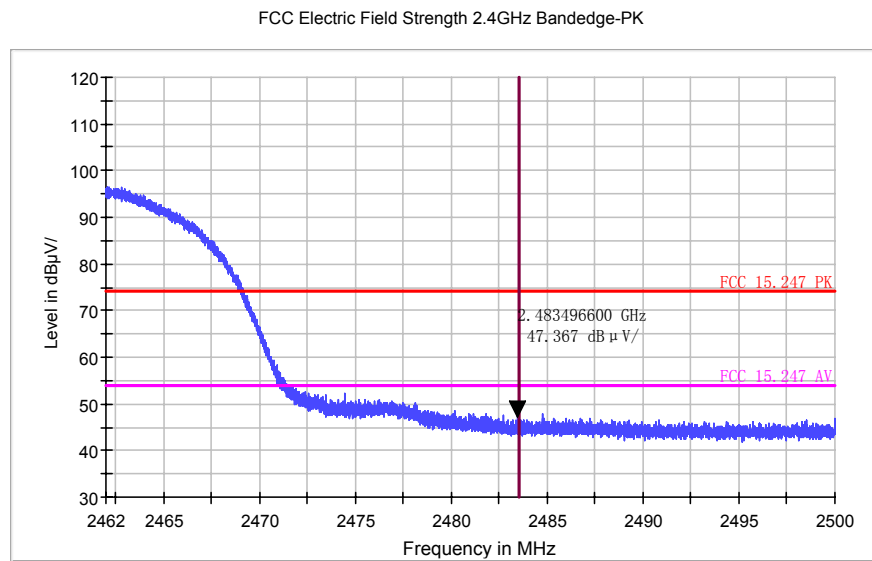

Frequency (MHz)	Result (dBuV/m)	Limit (dBuV/m)	Margin (dB)	Antenna	Remark
2483.4	47.93	74	-26.07	H	Peak
2483.4	37.95	54	-16.05	H	Average
2483.5	47.37	74	-26.63	V	Peak
2483.5	35.93	54	-18.07	V	Average



Mode 3: IEEE 802.11g Link Mode

2412/H

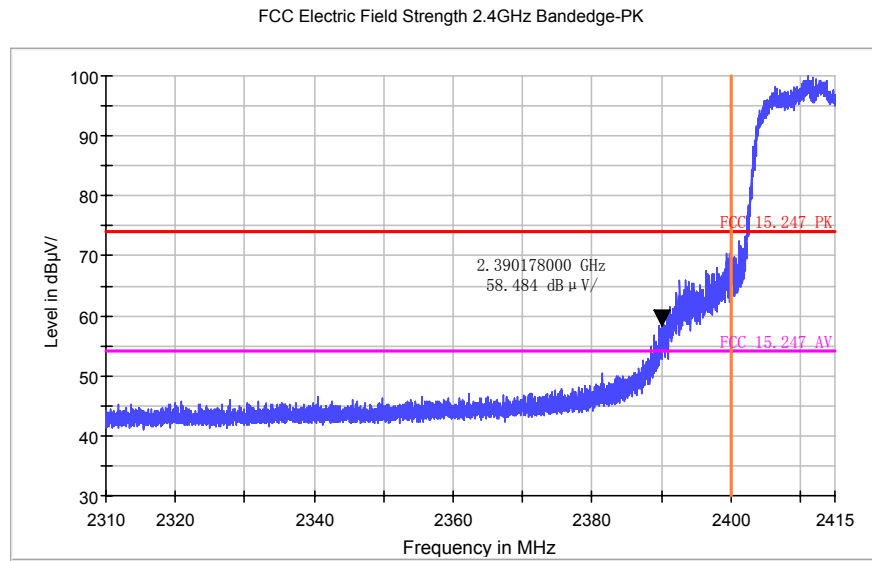

2412/V

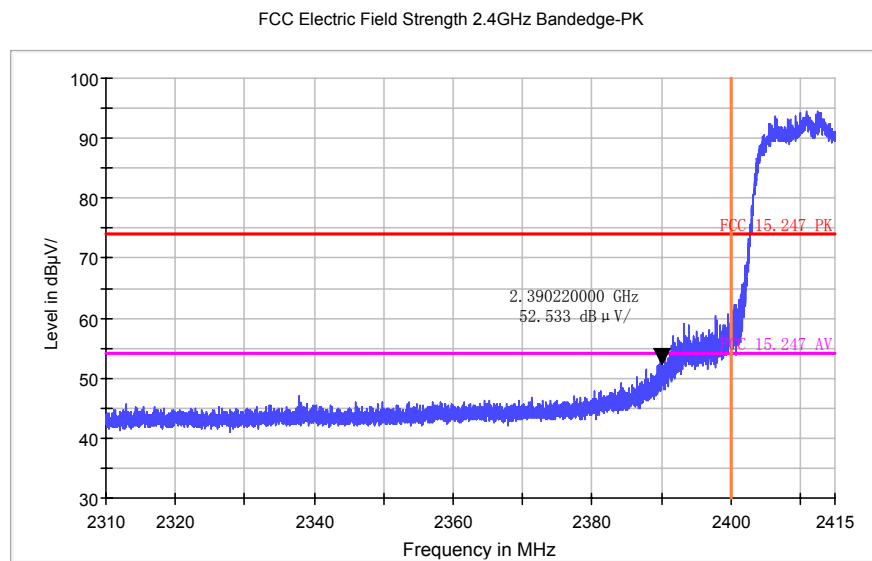

Frequency (MHz)	Result (dBuV/m)	Limit (dBuV/m)	Margin (dB)	Antenna	Remark
2390.2	58.48	74	-15.52	H	Peak
2390.2	44.34	54	-9.66	H	Average
2390.2	52.53	74	-21.47	V	Peak
2390.2	40.30	54	-13.7	V	Average



Mode 3: IEEE 802.11g Link Mode

2462/H

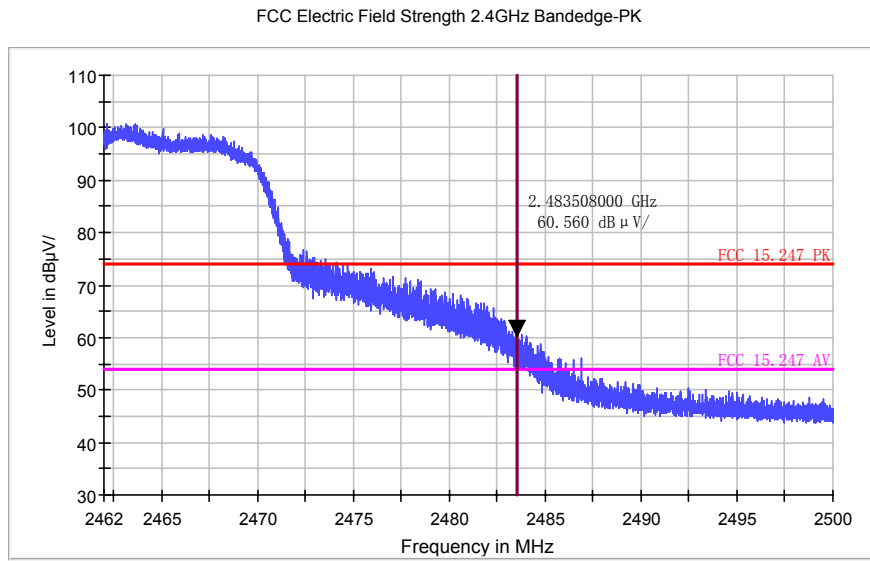

2462/V

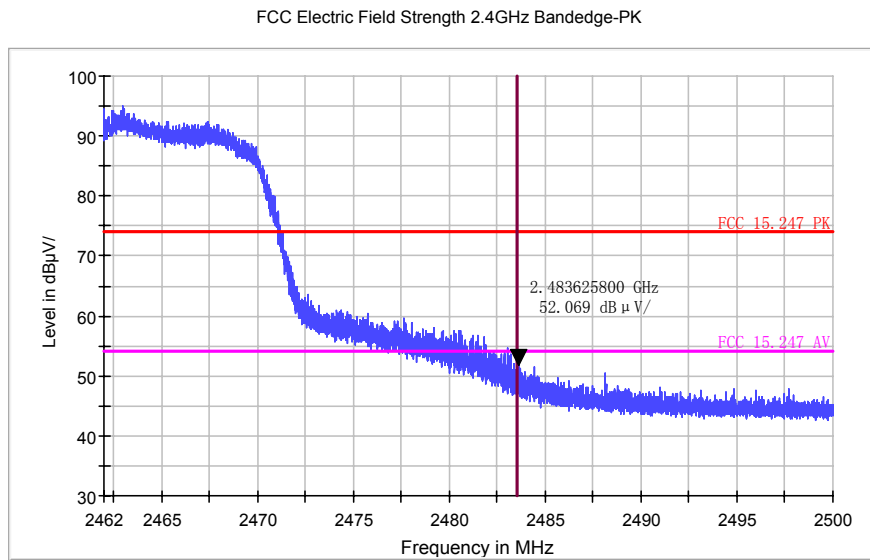

Frequency (MHz)	Result (dBuV/m)	Limit (dBuV/m)	Margin (dB)	Antenna	Remark
2483.5	60.56	74	-13.44	H	Peak
2483.5	46.75	54	-7.25	H	Average
2483.6	52.07	74	-21.93	V	Peak
2483.6	40.08	54	-13.92	V	Average



Mode 4: IEEE 802.11n 20MHz Link Mode

2412/H

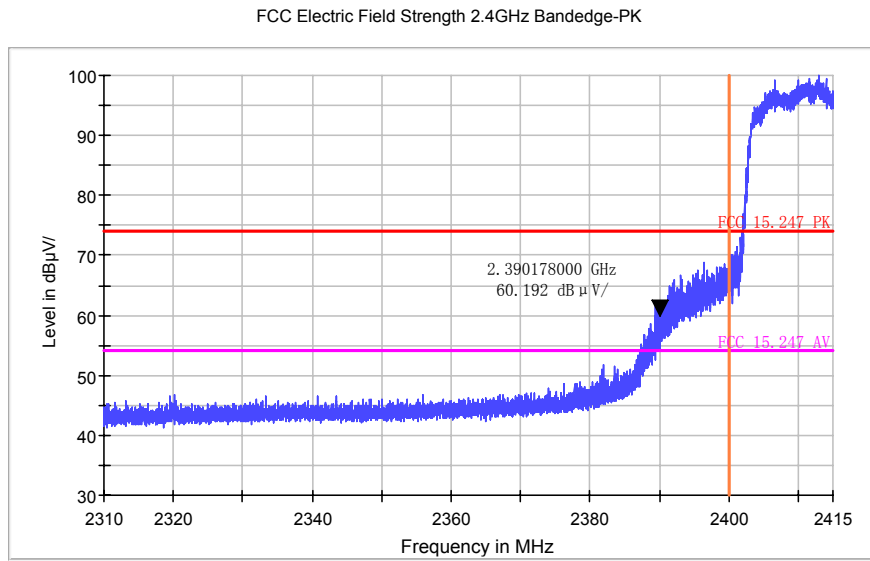

2412/V

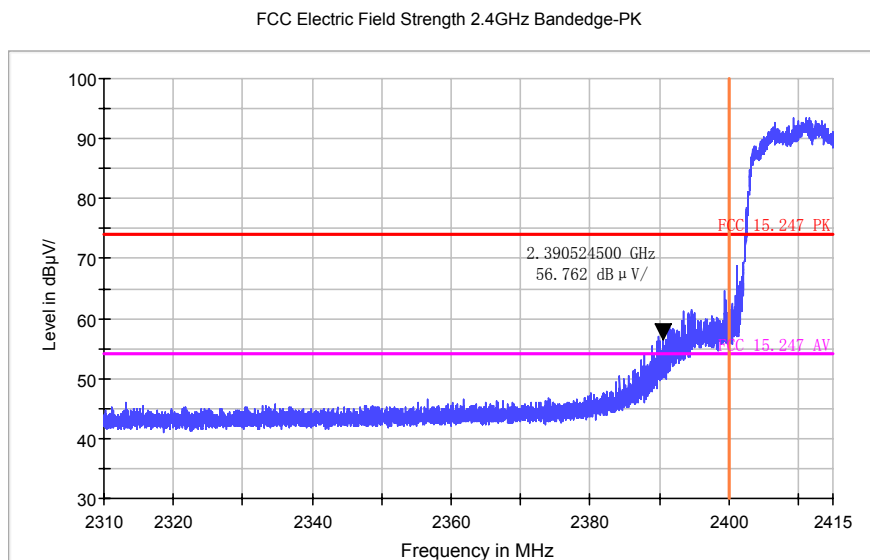

Frequency (MHz)	Result (dBuV/m)	Limit (dBuV/m)	Margin (dB)	Antenna	Remark
2390.2	60.19	74	-13.81	H	Peak
2390.2	47.88	54	-6.12	H	Average
2390.5	56.76	74	-17.24	V	Peak
2390.5	42.14	54	-11.86	V	Average



Mode 4: IEEE 802.11n 20MHz Link Mode

2462/H

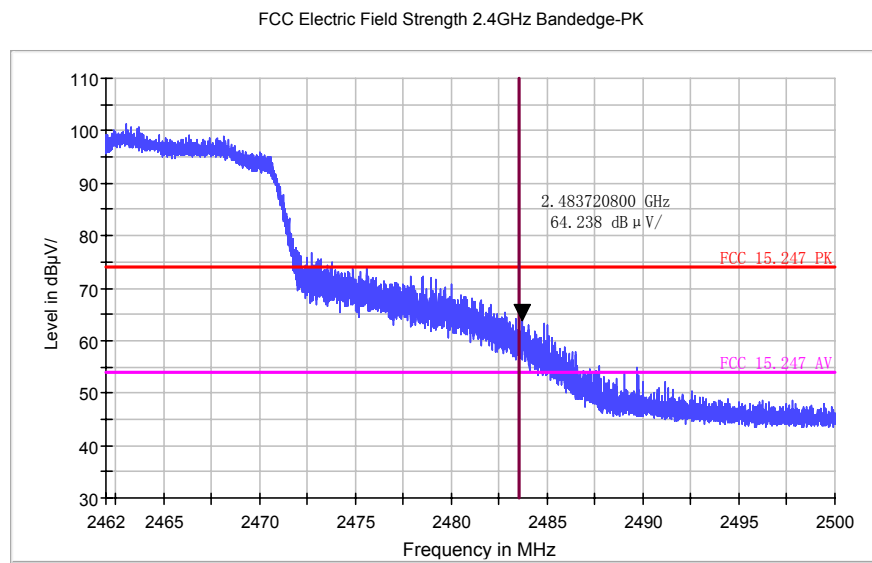

2462/V

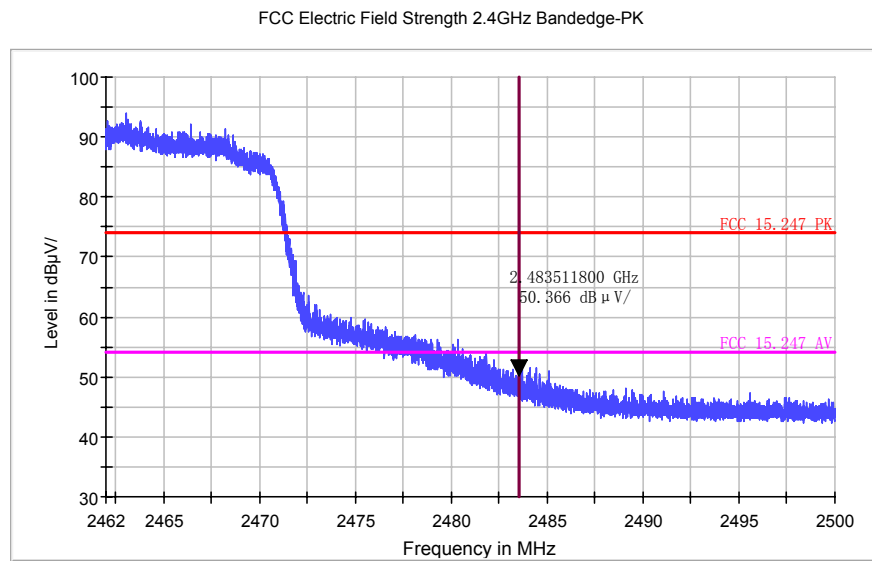

Frequency (MHz)	Result (dBuV/m)	Limit (dBuV/m)	Margin (dB)	Antenna	Remark
2483.7	64.24	74	-9.76	H	Peak
2483.7	49.60	54	-4.40	H	Average
2483.5	50.37	74	-23.63	V	Peak
2483.5	39.26	54	-14.74	V	Average



11 Antenna Measurement

11.1.Limit

For intentional device, according to 15.203, an intentional radiator shall be designed to ensure that no antenna other than that furnished by the responsible party shall be used with the device.

And According to 15.247 (b), if transmitting antennas of directional gain greater than 6 dBi are used, the power shall be reduced by the amount in dB that the directional gain of the antenna exceeds 6dBi.

11.2.Antenna Connector Construction

The antenna used in this product is FPC Antenna. And the maximum Gain of this antenna is 2.9 dBi.

.....**End of Report**.....