

Test Report

Report No. : MTi250319006-0104E1

Date of issue : 2025-07-23

Applicant : ShenZhen Cannice Technology Co., Ltd.

**Product : ONN TWS SPORT GEN2 WHT; ONN TWS SPORT
GEN2 BLK**

Model(s) : AAMNIM100150848, AAGHTR100150848

FCC ID : 2ADTV-50848

Shenzhen Microtest Co., Ltd.

TEST REPORT

Report No.: MTi250319006-0104E1

Table of contents

| | | |
|----------|---|-----------|
| 1 | General Description | 4 |
| 1.1 | Description of the EUT | 4 |
| 1.2 | Description of test modes | 4 |
| 1.3 | Environmental Conditions | 6 |
| 1.4 | Description of support units | 6 |
| 1.5 | Measurement uncertainty | 6 |
| 2 | Summary of Test Result | 7 |
| 3 | Test Facilities and accreditations | 8 |
| 3.1 | Test laboratory | 8 |
| 4 | List of test equipment | 9 |
| 5 | Evaluation Results (Evaluation) | 10 |
| 5.1 | Antenna requirement | 10 |
| 6 | Radio Spectrum Matter Test Results (RF) | 11 |
| 6.1 | 20dB Bandwidth | 11 |
| 6.2 | Maximum Conducted Output Power | 13 |
| 6.3 | Channel Separation | 15 |
| 6.4 | Number of Hopping Frequencies | 16 |
| 6.5 | Dwell Time | 18 |
| 6.6 | RF conducted spurious emissions and band edge measurement | 20 |
| 6.7 | Band edge emissions (Radiated) | 21 |
| 6.8 | Radiated emissions (below 1GHz) | 26 |
| 6.9 | Radiated emissions (above 1GHz) | 32 |
| | Photographs of the test setup | 39 |
| | Photographs of the EUT | 40 |
| | Appendix A: 20dB Emission Bandwidth | 42 |
| | Appendix B: Maximum conducted output power | 49 |
| | Appendix C: Carrier frequency separation | 56 |
| | Appendix D: Time of occupancy | 59 |
| | Appendix E: Number of hopping channels | 69 |
| | Appendix F: Band edge measurements | 72 |
| | Appendix G: Conducted Spurious Emission | 80 |

TEST REPORT

Report No.: MTi250319006-0104E1

| Test Result Certification | | |
|---------------------------|---|---|
| Applicant | ShenZhen Cannice Technology Co.,Ltd. | |
| Applicant Address | 20/F, Tower A, Building 7, Baoneng Science and Technology Park, Qingxiang Road #1, Longhua New District, Shenzhen, China | |
| Manufacturer | ShenZhen Cannice Technology Co.,Ltd. | |
| Manufacturer Address | 20/F, Tower A, Building 7, Baoneng Science and Technology Park, Qingxiang Road #1, Longhua New District, Shenzhen, China | |
| Factory | PACIFIC CYBER TECHNOLOGY PRIVATE LIMITED | |
| Factory Address | 57/3/55,57/2/56,57/1/57, SILVER INDUSTRIAL ESTATE BHIMPORE,NANI DAMAN,Daman,Dadra and Nagar Haveli and Daman and Diu,396210 | |
| Product description | | |
| Product name | ONN TWS SPORT GEN2 WHT; ONN TWS SPORT GEN2 BLK | |
| Trademark | ONN | |
| Model name | AAMNIM100150848 | |
| Series Model(s) | AAGHTR100150848 | |
| Standards | 47 CFR Part 15.247 | |
| Test Method | KDB 558074 D01 15.247 Meas Guidance v05r02 ANSI C63.10-2013 | |
| Testing Information | | |
| Date of test | 2025-07-10 to 2025-07-16 | |
| Test result | Pass | |
| Prepared by: | James Qin |  |
| Reviewed by: | David Lee |  |
| Approved by: | Lewis Lian |  |

TEST REPORT

Report No.: MTi250319006-0104E1

1 General Description

1.1 Description of the EUT

| | |
|----------------------------|---|
| Product name: | ONN TWS SPORT GEN2 WHT; ONN TWS SPORT GEN2 BLK |
| Model name: | AAMNIM100150848 |
| Series Model(s): | AAGHTR100150848 |
| Model difference: | All the models are the same circuit and module, except the model name and color. |
| Electrical rating: | Input: DC 5V Battery: Earbuds: DC 3.7V 60mAh Charging case: DC 3.7V 650mAh |
| Accessories: | N/A |
| Hardware version: | V0D |
| Software version: | V |
| Test sample(s) number: | MTi250319006-01-R001 MTi250319006-01-R002 |
| RF specification | |
| Bluetooth version: | V5.4 |
| Operating frequency range: | 2402-2480 MHz |
| Channel number: | 79 |
| Modulation type: | GFSK, $\pi/4$ -DQPSK |
| Antenna(s) type: | FPC |
| Antenna(s) gain: | L: -2.47dBi, R: -3.28dBi |

1.2 Description of test modes

| No. | Emission test modes |
|-------|----------------------------------|
| Mode1 | TX-GFSK-Left earbuds |
| Mode2 | TX-GFSK-Right earbuds |
| Mode3 | TX- $\pi/4$ -DQPSK-Left earbuds |
| Mode4 | TX- $\pi/4$ -DQPSK-Right earbuds |

Left earbuds: ANT1, Right earbuds: ANT2

1.2.1 Operation channel list

| Channel | Frequency (MHz) | Channel | Frequency (MHz) | Channel | Frequency (MHz) | Channel | Frequency (MHz) |
|---------|-----------------|---------|-----------------|---------|-----------------|---------|-----------------|
| 0 | 2402 | 20 | 2422 | 40 | 2442 | 60 | 2462 |
| 1 | 2403 | 21 | 2423 | 41 | 2443 | 61 | 2463 |
| 2 | 2404 | 22 | 2424 | 42 | 2444 | 62 | 2464 |

TEST REPORT

Report No.: MTi250319006-0104E1

| | | | | | | | |
|----|------|----|------|----|------|----|------|
| 3 | 2405 | 23 | 2425 | 43 | 2445 | 63 | 2465 |
| 4 | 2406 | 24 | 2426 | 44 | 2446 | 64 | 2466 |
| 5 | 2407 | 25 | 2427 | 45 | 2447 | 65 | 2467 |
| 6 | 2408 | 26 | 2428 | 46 | 2448 | 66 | 2468 |
| 7 | 2409 | 27 | 2429 | 47 | 2449 | 67 | 2469 |
| 8 | 2410 | 28 | 2430 | 48 | 2450 | 68 | 2470 |
| 9 | 2411 | 29 | 2431 | 49 | 2451 | 69 | 2471 |
| 10 | 2412 | 30 | 2432 | 50 | 2452 | 70 | 2472 |
| 11 | 2413 | 31 | 2433 | 51 | 2453 | 71 | 2473 |
| 12 | 2414 | 32 | 2434 | 52 | 2454 | 72 | 2474 |
| 13 | 2415 | 33 | 2435 | 53 | 2455 | 73 | 2475 |
| 14 | 2416 | 34 | 2436 | 54 | 2456 | 74 | 2476 |
| 15 | 2417 | 35 | 2437 | 55 | 2457 | 75 | 2477 |
| 16 | 2418 | 36 | 2438 | 56 | 2458 | 76 | 2478 |
| 17 | 2419 | 37 | 2439 | 57 | 2459 | 77 | 2479 |
| 18 | 2420 | 38 | 2440 | 58 | 2460 | 78 | 2480 |
| 19 | 2421 | 39 | 2441 | 59 | 2461 | - | - |

Test Channel List

Operation Band: 2400-2483.5 MHz

| Bandwidth (MHz) | Lowest Channel (LCH) (MHz) | Middle Channel (MCH) (MHz) | Highest Channel (HCH) (MHz) |
|-----------------|----------------------------|----------------------------|-----------------------------|
| 1 | 2402 | 2441 | 2480 |

Note: The test software provided by manufacturer is used to control EUT for working in engineering mode, that enables selectable channel, and capable of continuous transmitting mode.

Test Software: FCC Assist 1.0.2.2

For power setting, refer to below table.

| Mode | 2402MHz | 2441MHz | 2480MHz |
|----------------|---------|---------|---------|
| GFSK | 10 | 10 | 10 |
| $\pi/4$ -DQPSK | 10 | 10 | 10 |

TEST REPORT

Report No.: MTi250319006-0104E1

1.3 Environmental Conditions

During the measurement the environmental conditions were within the listed ranges:

| | |
|-----------------------|------------------|
| Temperature: | 15°C ~ 35°C |
| Humidity: | 20% RH ~ 75% RH |
| Atmospheric pressure: | 98 kPa ~ 101 kPa |

1.4 Description of support units

| Support equipment list | | | |
|------------------------|-------|------------|--------------|
| Description | Model | Serial No. | Manufacturer |
| / | / | / | / |

| Support cable list | | | |
|--------------------|------------|------|----|
| Description | Length (m) | From | To |
| / | / | / | / |

1.5 Measurement uncertainty

| Measurement | Uncertainty |
|--|-------------|
| Occupied channel bandwidth | ±3 % |
| RF output power, conducted | ±1 dB |
| Time | ±1 % |
| Unwanted Emissions, conducted | ±1 dB |
| Radiated spurious emissions (above 1GHz) | ±5.3dB |
| Radiated spurious emissions (9kHz~30MHz) | ±4.3dB |
| Radiated spurious emissions (30MHz~1GHz) | ±4.7dB |
| Temperature | ±1 °C |
| Humidity | ± 5 % |

This uncertainty represents an expanded uncertainty expressed at approximately the 95% confidence level using a coverage factor of k=2.

TEST REPORT

Report No.: MTi250319006-0104E1

2 Summary of Test Result

| No. | Item | Standard | Requirement | Result |
|-----|---|--------------------|----------------------------------|--------|
| 1 | Antenna requirement | 47 CFR Part 15.247 | 47 CFR 15.203 | Pass |
| 2 | 20dB Bandwidth | 47 CFR Part 15.247 | 47 CFR 15.247(a)(1) | Pass |
| 3 | Maximum Conducted Output Power | 47 CFR Part 15.247 | 47 CFR 15.247(b)(1) | Pass |
| 4 | Channel Separation | 47 CFR Part 15.247 | 47 CFR 15.247(a)(1) | Pass |
| 5 | Number of Hopping Frequencies | 47 CFR Part 15.247 | 47 CFR 15.247(a)(1)(iii) | Pass |
| 6 | Dwell Time | 47 CFR Part 15.247 | 47 CFR 15.247(a)(1)(iii) | Pass |
| 7 | RF conducted spurious emissions and band edge measurement | 47 CFR Part 15.247 | 47 CFR 15.247(d) | Pass |
| 8 | Band edge emissions (Radiated) | 47 CFR Part 15.247 | 47 CFR 15.247(d), 15.209, 15.205 | Pass |
| 9 | Radiated emissions (below 1GHz) | 47 CFR Part 15.247 | 47 CFR 15.247(d), 15.209, 15.205 | Pass |
| 10 | Radiated emissions (above 1GHz) | 47 CFR Part 15.247 | 47 CFR 15.247(d), 15.209, 15.205 | Pass |

TEST REPORT

Report No.: MTi250319006-0104E1

3 Test Facilities and accreditations

3.1 Test laboratory

| | |
|------------------------|--|
| Test laboratory: | Shenzhen Microtest Co., Ltd. |
| Test site location: | 101, No.7, Zone 2, Xinxing Industrial Park, Fuhai Avenue, Xinhe Community, Fuhai Street, Bao'an District, Shenzhen, Guangdong, China |
| Telephone: | (86-755)88850135 |
| Fax: | (86-755)88850136 |
| CNAS Registration No.: | CNAS L5868 |
| FCC Registration No.: | 448573 |
| IC Registration No.: | 21760 |
| CABID: | CN0093 |

TEST REPORT

Report No.: MTi250319006-0104E1

4 List of test equipment

| No. | Equipment | Manufacturer | Model | Serial No. | Cal. date | Cal. Due |
|--|--------------------------------------|-----------------|-------------|------------|------------|------------|
| Channel Separation Number of Hopping Frequencies Dwell Time Emissions in non-restricted frequency bands 20dB Bandwidth Maximum Conducted Output Power | | | | | | |
| 1 | Wideband Radio Communication Tester | Rohde&schwarz | CMW500 | 149155 | 2025-03-18 | 2026-03-17 |
| 2 | ESG Series Analog Ssignal Generator | Agilent | E4421B | GB40051240 | 2025-03-14 | 2026-03-13 |
| 3 | PXA Signal Analyzer | Agilent | N9030A | MY51350296 | 2025-03-14 | 2026-03-13 |
| 4 | Synthesized Sweeper | Agilent | 83752A | 3610A01957 | 2025-03-14 | 2026-03-13 |
| 5 | MXA Signal Analyzer | Agilent | N9020A | MY50143483 | 2025-03-14 | 2026-03-13 |
| 6 | RF Control Unit | Tonscend | JS0806-1 | 19D8060152 | 2025-03-18 | 2026-03-17 |
| 7 | Band Reject Filter Group | Tonscend | JS0806-F | 19D8060160 | 2025-03-14 | 2026-03-13 |
| 8 | ESG Vector Signal Generator | Agilent | N5182A | MY50143762 | 2025-03-14 | 2026-03-13 |
| 9 | DC Power Supply | Agilent | E3632A | MY40027695 | 2025-03-18 | 2026-03-17 |
| Band edge emissions (Radiated) Emissions in frequency bands (above 1GHz) | | | | | | |
| 1 | EMI Test Receiver | Rohde&schwarz | ESC17 | 101166 | 2025-03-14 | 2026-03-13 |
| 2 | Double Ridged Broadband Horn Antenna | schwarabeck | BBHA 9120 D | 2278 | 2025-05-27 | 2027-05-26 |
| 3 | Amplifier | Agilent | 8449B | 3008A01120 | 2025-03-18 | 2026-03-17 |
| 4 | MXA signal analyzer | Agilent | N9020A | MY54440859 | 2025-03-14 | 2026-03-13 |
| 5 | PXA Signal Analyzer | Agilent | N9030A | MY51350296 | 2025-03-14 | 2026-03-13 |
| 6 | Horn antenna | Schwarzbeck | BBHA 9170 | 00987 | 2025-05-27 | 2027-05-26 |
| 7 | Pre-amplifier | Space-Dtronics | EWLAN1840G | 210405001 | 2025-03-19 | 2026-03-18 |
| Emissions in frequency bands (below 1GHz) | | | | | | |
| 1 | EMI Test Receiver | Rohde&schwarz | ESC17 | 101166 | 2025-03-14 | 2026-03-13 |
| 2 | TRILOG Broadband Antenna | schwarabeck | VULB 9163 | 9163-1338 | 2025-05-23 | 2027-05-22 |
| 3 | Active Loop Antenna | Schwarzbeck | FMZB 1519 B | 00066 | 2024-03-23 | 2026-03-22 |
| 4 | Amplifier | Hewlett-Packard | 8447F | 3113A06184 | 2025-03-18 | 2026-03-17 |

TEST REPORT

Report No.: MTi250319006-0104E1

5 Evaluation Results (Evaluation)

5.1 Antenna requirement

| | |
|-------------------|---|
| Test Requirement: | Refer to 47 CFR Part 15.203, an intentional radiator shall be designed to ensure that no antenna other than that furnished by the responsible party shall be used with the device. The use of a permanently attached antenna or of an antenna that uses a unique coupling to the intentional radiator shall be considered sufficient to comply with the provisions of this section. |
|-------------------|---|

5.1.1 Conclusion:

| |
|--|
| The antenna of the EUT is permanently attached. The EUT complies with the requirement of FCC PART 15.203. |
|--|

TEST REPORT

Report No.: MTi250319006-0104E1

6 Radio Spectrum Matter Test Results (RF)

6.1 20dB Bandwidth

| | |
|-------------------|---|
| Test Requirement: | 47 CFR 15.247(a)(1) |
| Test Limit: | Refer to 47 CFR 15.215(c), intentional radiators operating under the alternative provisions to the general emission limits, as contained in §§ 15.217 through 15.257 and in subpart E of this part, must be designed to ensure that the 20 dB bandwidth of the emission, or whatever bandwidth may otherwise be specified in the specific rule section under which the equipment operates, is contained within the frequency band designated in the rule section under which the equipment is operated. |
| Test Method: | ANSI C63.10-2013, section 7.8.7, For occupied bandwidth measurements, use the procedure in 6.9.2. KDB 558074 D01 15.247 Meas Guidance v05r02 |
| Procedure: | <p>a) The spectrum analyzer center frequency is set to the nominal EUT channel center frequency. The span range for the EMI receiver or spectrum analyzer shall be between two times and five times the OBW.</p> <p>b) The nominal IF filter bandwidth (3 dB RBW) shall be in the range of 1% to 5% of the OBW and video bandwidth (VBW) shall be approximately three times RBW, unless otherwise specified by the applicable requirement.</p> <p>c) Set the reference level of the instrument as required, keeping the signal from exceeding the maximum input mixer level for linear operation. In general, the peak of the spectral envelope shall be more than $[10 \log (OBW/RBW)]$ below the reference level. Specific guidance is given in 4.1.5.2.</p> <p>d) Steps a) through c) might require iteration to adjust within the specified tolerances.</p> <p>e) The dynamic range of the instrument at the selected RBW shall be more than 10 dB below the target “-xx dB down” requirement; that is, if the requirement calls for measuring the -20 dB OBW, the instrument noise floor at the selected RBW shall be at least 30 dB below the reference value.</p> <p>f) Set detection mode to peak and trace mode to max hold.</p> <p>g) Determine the reference value: Set the EUT to transmit an unmodulated carrier or modulated signal, as applicable. Allow the trace to stabilize. Set the spectrum analyzer marker to the highest level of the displayed trace (this is the reference value).</p> <p>h) Determine the “-xx dB down amplitude” using $[(\text{reference value}) - xx]$. Alternatively, this calculation may be made by using the marker-delta function of the instrument.</p> <p>i) If the reference value is determined by an unmodulated carrier, then turn the EUT modulation ON, and either clear the existing trace or start a new trace on the spectrum analyzer and allow the new trace to stabilize. Otherwise, the trace from step g) shall be used for step j).</p> <p>j) Place two markers, one at the lowest frequency and the other at the highest frequency of the envelope of the spectral display, such that each marker is at or slightly below the “-xx dB down amplitude” determined in step h). If a marker is below this “-xx dB down amplitude” value, then it shall be as close as possible to this value. The occupied bandwidth is the frequency difference between the two markers. Alternatively, set a marker at the lowest frequency of the envelope of the spectral display, such that the marker is at or slightly below the “-xx dB down amplitude” determined in step h). Reset the marker-delta function and</p> |

TEST REPORT

Report No.: MTi250319006-0104E1

| | |
|--|---|
| | move the marker to the other side of the emission until the delta marker amplitude is at the same level as the reference marker amplitude. The marker-delta frequency reading at this point is the specified emission bandwidth. k) The occupied bandwidth shall be reported by providing plot(s) of the measuring instrument display; the plot axes and the scale units per division shall be clearly labeled. Tabular data may be reported in addition to the plot(s). |
|--|---|

6.1.1 E.U.T. Operation:

| | | | | | |
|------------------------|----------------------------|-----------|------|-----------------------|---------|
| Operating Environment: | | | | | |
| Temperature: | 25.1 °C | Humidity: | 59 % | Atmospheric Pressure: | 101 kPa |
| Pre test mode: | Mode1, Mode2, Mode3, Mode4 | | | | |
| Final test mode: | Mode1, Mode2, Mode3, Mode4 | | | | |

6.1.2 Test Setup Diagram:

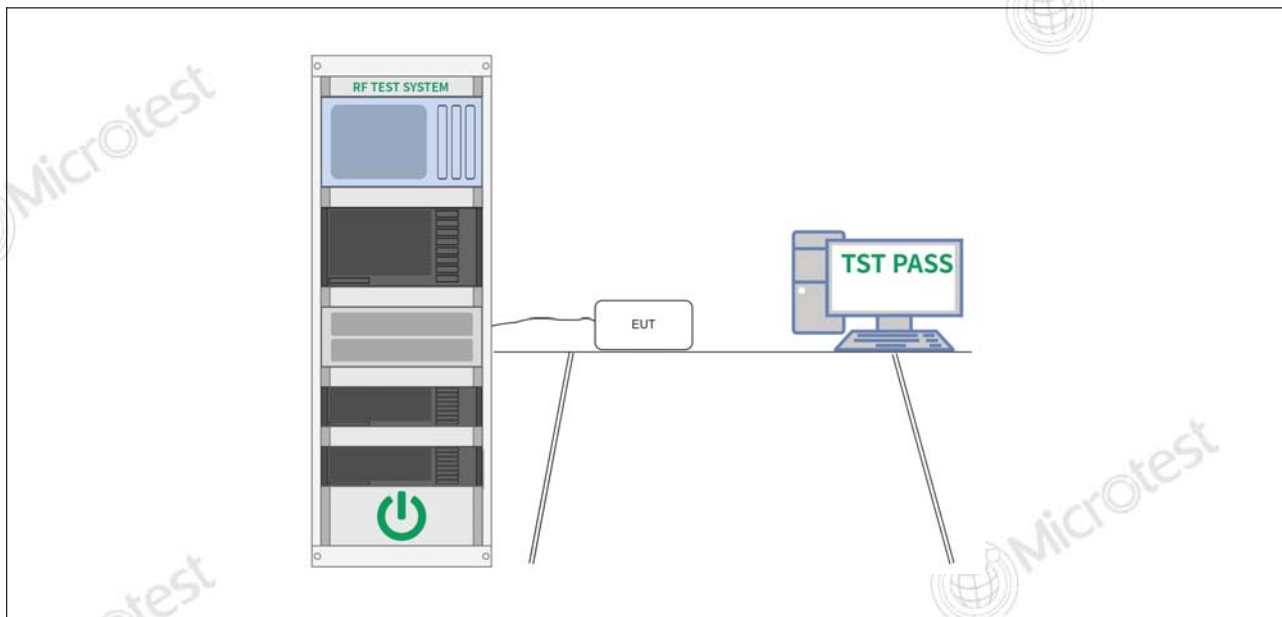

6.1.3 Test Data:

Please Refer to Appendix for Details.

TEST REPORT

Report No.: MTi250319006-0104E1

6.2 Maximum Conducted Output Power

| | |
|-------------------|---|
| Test Requirement: | 47 CFR 15.247(b)(1) |
| Test Limit: | Refer to 47 CFR 15.247(b)(1), For frequency hopping systems operating in the 2400-2483.5 MHz band employing at least 75 non-overlapping hopping channels, and all frequency hopping systems in the 5725-5850 MHz band: 1 watt. For all other frequency hopping systems in the 2400-2483.5 MHz band: 0.125 watts. |
| Test Method: | ANSI C63.10-2013, section 7.8.5 KDB 558074 D01 15.247 Meas Guidance v05r02 |
| Procedure: | <p>This is an RF-conducted test to evaluate maximum peak output power. Use a direct connection between the antenna port of the unlicensed wireless device and the spectrum analyzer, through suitable attenuation. The hopping shall be disabled for this test:</p> <p>a) Use the following spectrum analyzer settings:</p> <ol style="list-style-type: none"> 1) Span: Approximately five times the 20 dB bandwidth, centered on a hopping channel. 2) RBW > 20 dB bandwidth of the emission being measured. 3) VBW >= RBW. 4) Sweep: Auto. 5) Detector function: Peak. 6) Trace: Max hold. <p>b) Allow trace to stabilize.</p> <p>c) Use the marker-to-peak function to set the marker to the peak of the emission.</p> <p>d) The indicated level is the peak output power, after any corrections for external attenuators and cables.</p> <p>e) A plot of the test results and setup description shall be included in the test report.</p> <p>NOTE—A peak responding power meter may be used, where the power meter and sensor system video bandwidth is greater than the occupied bandwidth of the unlicensed wireless device, rather than a spectrum analyzer.</p> |

6.2.1 E.U.T. Operation:

| | | | | | |
|------------------------|----------------------------|-----------|------|-----------------------|---------|
| Operating Environment: | | | | | |
| Temperature: | 25.1 °C | Humidity: | 59 % | Atmospheric Pressure: | 101 kPa |
| Pre test mode: | Mode1, Mode2, Mode3, Mode4 | | | | |
| Final test mode: | Mode1, Mode2, Mode3, Mode4 | | | | |

TEST REPORT

Report No.: MTi250319006-0104E1

6.2.2 Test Setup Diagram:

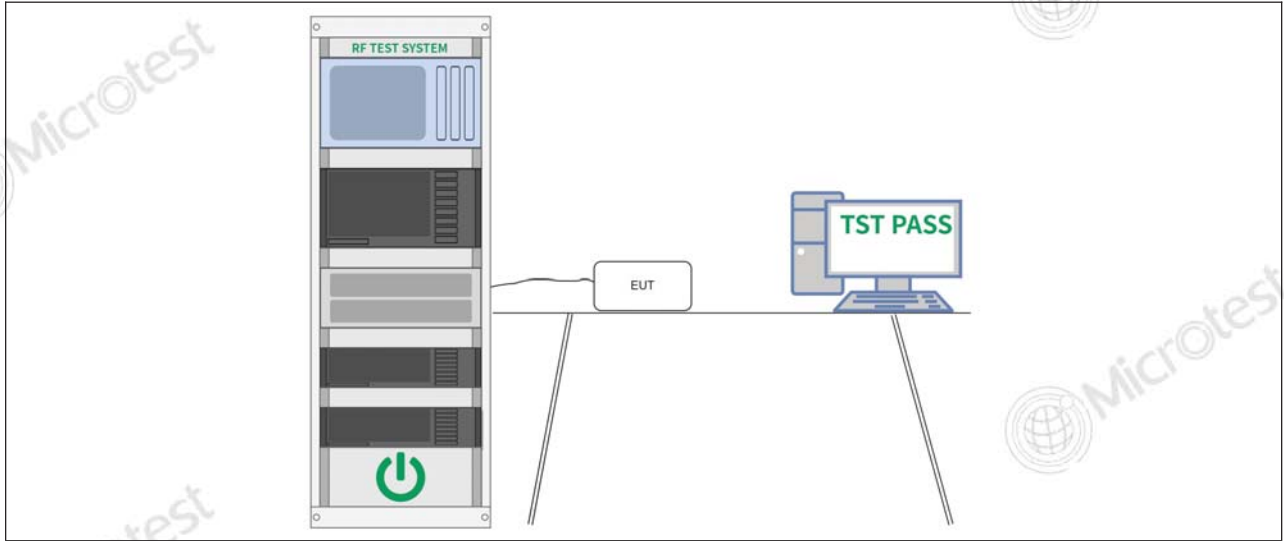

6.2.3 Test Data:

Please Refer to Appendix for Details.

TEST REPORT

Report No.: MTi250319006-0104E1

6.3 Channel Separation

| | |
|-------------------|---|
| Test Requirement: | 47 CFR 15.247(a)(1) |
| Test Limit: | Refer to 47 CFR 15.247(a)(1), Frequency hopping systems shall have hopping channel carrier frequencies separated by a minimum of 25 kHz or the 20 dB bandwidth of the hopping channel, whichever is greater. Alternatively, frequency hopping systems operating in the 2400-2483.5 MHz band may have hopping channel carrier frequencies that are separated by 25 kHz or two-thirds of the 20 dB bandwidth of the hopping channel, whichever is greater, provided the systems operate with an output power no greater than 125 mW. |
| Test Method: | ANSI C63.10-2013, section 7.8.2 KDB 558074 D01 15.247 Meas Guidance v05r02 |
| Procedure: | <p>The EUT shall have its hopping function enabled. Use the following spectrum analyzer settings:</p> <ul style="list-style-type: none"> a) Span: Wide enough to capture the peaks of two adjacent channels. b) RBW: Start with the RBW set to approximately 30% of the channel spacing; adjust as necessary to best identify the center of each individual channel. c) Video (or average) bandwidth (VBW) \geq RBW. d) Sweep: Auto. e) Detector function: Peak. f) Trace: Max hold. g) Allow the trace to stabilize. <p>Use the marker-delta function to determine the separation between the peaks of the adjacent channels. Compliance of an EUT with the appropriate regulatory limit shall be determined. A plot of the data shall be included in the test report.</p> |

6.3.1 E.U.T. Operation:

| | | | | | |
|------------------------|----------------------------|-----------|------|-----------------------|---------|
| Operating Environment: | | | | | |
| Temperature: | 25.1 °C | Humidity: | 59 % | Atmospheric Pressure: | 101 kPa |
| Pre test mode: | Mode1, Mode2, Mode3, Mode4 | | | | |
| Final test mode: | Mode1, Mode2, Mode3, Mode4 | | | | |

6.3.2 Test Setup Diagram:

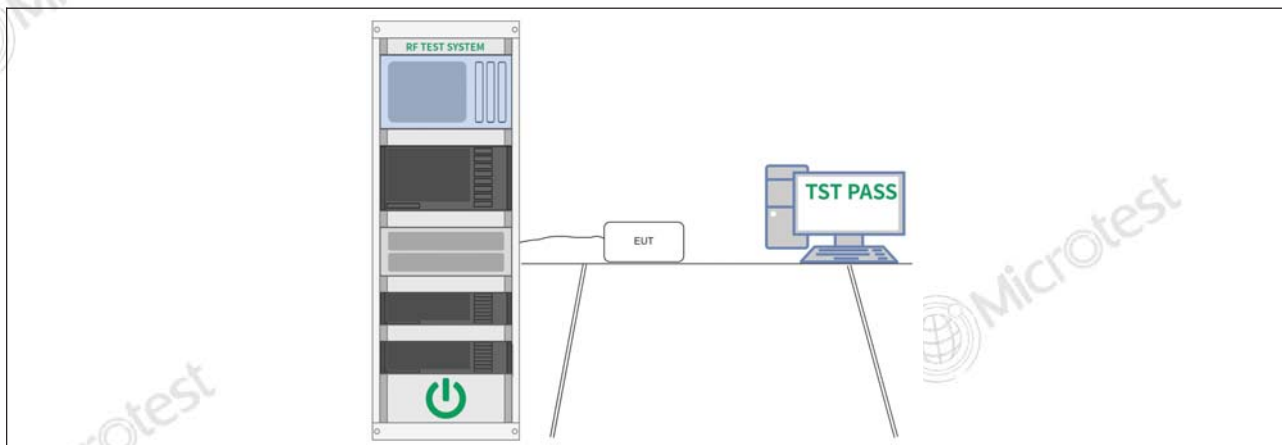

6.3.3 Test Data:

Please Refer to Appendix for Details.

TEST REPORT

Report No.: MTi250319006-0104E1

6.4 Number of Hopping Frequencies

| | |
|-------------------|---|
| Test Requirement: | 47 CFR 15.247(a)(1)(iii) |
| Test Limit: | Refer to 47 CFR 15.247(a)(1)(iii), Frequency hopping systems in the 2400-2483.5 MHz band shall use at least 15 channels. The average time of occupancy on any channel shall not be greater than 0.4 seconds within a period of 0.4 seconds multiplied by the number of hopping channels employed. Frequency hopping systems may avoid or suppress transmissions on a particular hopping frequency provided that a minimum of 15 channels are used. |
| Test Method: | ANSI C63.10-2013, section 7.8.3 KDB 558074 D01 15.247 Meas Guidance v05r02 |
| Procedure: | <p>The EUT shall have its hopping function enabled. Use the following spectrum analyzer settings:</p> <ul style="list-style-type: none"> a) Span: The frequency band of operation. Depending on the number of channels the device supports, it may be necessary to divide the frequency range of operation across multiple spans, to allow the individual channels to be clearly seen. b) RBW: To identify clearly the individual channels, set the RBW to less than 30% of the channel spacing or the 20 dB bandwidth, whichever is smaller. c) VBW \geq RBW. d) Sweep: Auto. e) Detector function: Peak. f) Trace: Max hold. g) Allow the trace to stabilize. <p>It might prove necessary to break the span up into subranges to show clearly all of the hopping frequencies. Compliance of an EUT with the appropriate regulatory limit shall be determined for the number of hopping channels. A plot of the data shall be included in the test report.</p> |

6.4.1 E.U.T. Operation:

| | | | | | |
|------------------------|----------------------------|-----------|------|-----------------------|---------|
| Operating Environment: | | | | | |
| Temperature: | 25.1 °C | Humidity: | 59 % | Atmospheric Pressure: | 101 kPa |
| Pre test mode: | Mode1, Mode2, Mode3, Mode4 | | | | |
| Final test mode: | Mode1, Mode2, Mode3, Mode4 | | | | |

6.4.2 Test Setup Diagram:

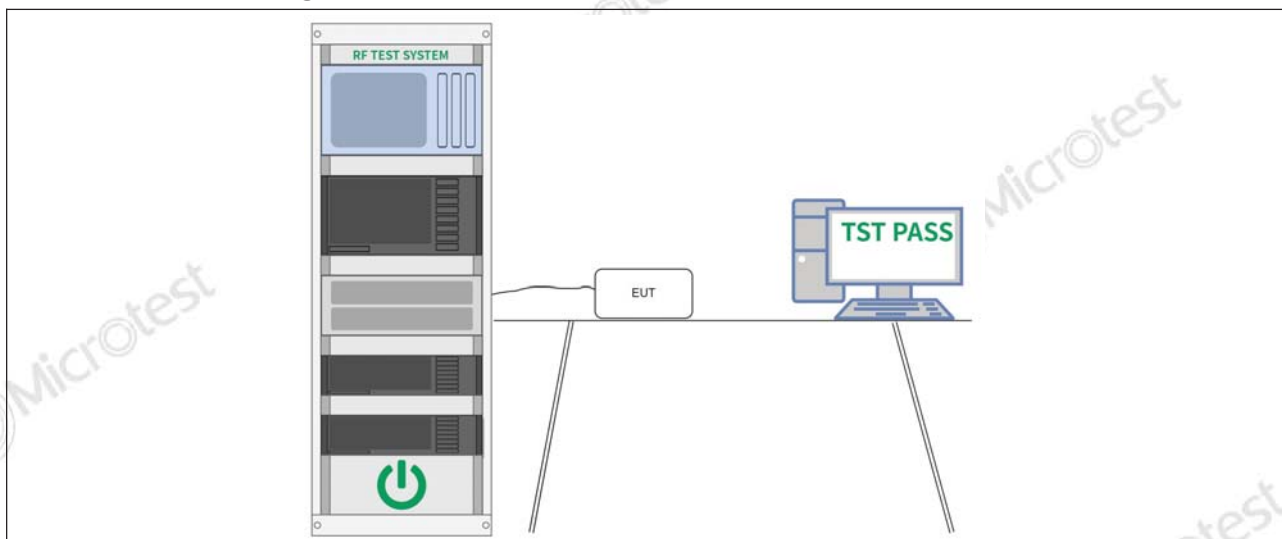

TEST REPORT

Report No.: MTi250319006-0104E1

6.4.3 Test Data:

Please Refer to Appendix for Details.

TEST REPORT

Report No.: MTi250319006-0104E1

6.5 Dwell Time

| | |
|-------------------|---|
| Test Requirement: | 47 CFR 15.247(a)(1)(iii) |
| Test Limit: | Refer to 47 CFR 15.247(a)(1)(iii), Frequency hopping systems in the 2400-2483.5 MHz band shall use at least 15 channels. The average time of occupancy on any channel shall not be greater than 0.4 seconds within a period of 0.4 seconds multiplied by the number of hopping channels employed. Frequency hopping systems may avoid or suppress transmissions on a particular hopping frequency provided that a minimum of 15 channels are used. |
| Test Method: | ANSI C63.10-2013, section 7.8.4 KDB 558074 D01 15.247 Meas Guidance v05r02 |
| Procedure: | <p>The EUT shall have its hopping function enabled. Use the following spectrum analyzer settings:</p> <p>a) Span: Zero span, centered on a hopping channel.</p> <p>b) RBW shall be \leq channel spacing and where possible RBW should be set $\gg 1 / T$, where T is the expected dwell time per channel.</p> <p>c) Sweep: As necessary to capture the entire dwell time per hopping channel; where possible use a video trigger and trigger delay so that the transmitted signal starts a little to the right of the start of the plot. The trigger level might need slight adjustment to prevent triggering when the system hops on an adjacent channel; a second plot might be needed with a longer sweep time to show two successive hops on a channel.</p> <p>d) Detector function: Peak.</p> <p>e) Trace: Max hold.</p> <p>Use the marker-delta function to determine the transmit time per hop. If this value varies with different modes of operation (data rate, modulation format, number of hopping channels, etc.), then repeat this test for each variation in transmit time.</p> <p>Repeat the measurement using a longer sweep time to determine the number of hops over the period specified in the requirements. The sweep time shall be equal to, or less than, the period specified in the requirements. Determine the number of hops over the sweep time and calculate the total number of hops in the period specified in the requirements, using the following equation:</p> $(\text{Number of hops in the period specified in the requirements}) = (\text{number of hops on spectrum analyzer}) \times (\text{period specified in the requirements} / \text{analyzer sweep time})$ <p>The average time of occupancy is calculated from the transmit time per hop multiplied by the number of hops in the period specified in the requirements. If the number of hops in a specific time varies with different modes of operation (data rate, modulation format, number of hopping channels, etc.), then repeat this test for each variation.</p> <p>The measured transmit time and time between hops shall be consistent with the values described in the operational description for the EUT.</p> |

6.5.1 E.U.T. Operation:

| | | | | | |
|------------------------|----------------------------|-----------|------|-----------------------|---------|
| Operating Environment: | | | | | |
| Temperature: | 25.1 °C | Humidity: | 59 % | Atmospheric Pressure: | 101 kPa |
| Pre test mode: | Mode1, Mode2, Mode3, Mode4 | | | | |
| Final test mode: | Mode1, Mode2, Mode3, Mode4 | | | | |

TEST REPORT

Report No.: MTi250319006-0104E1

6.5.2 Test Setup Diagram:

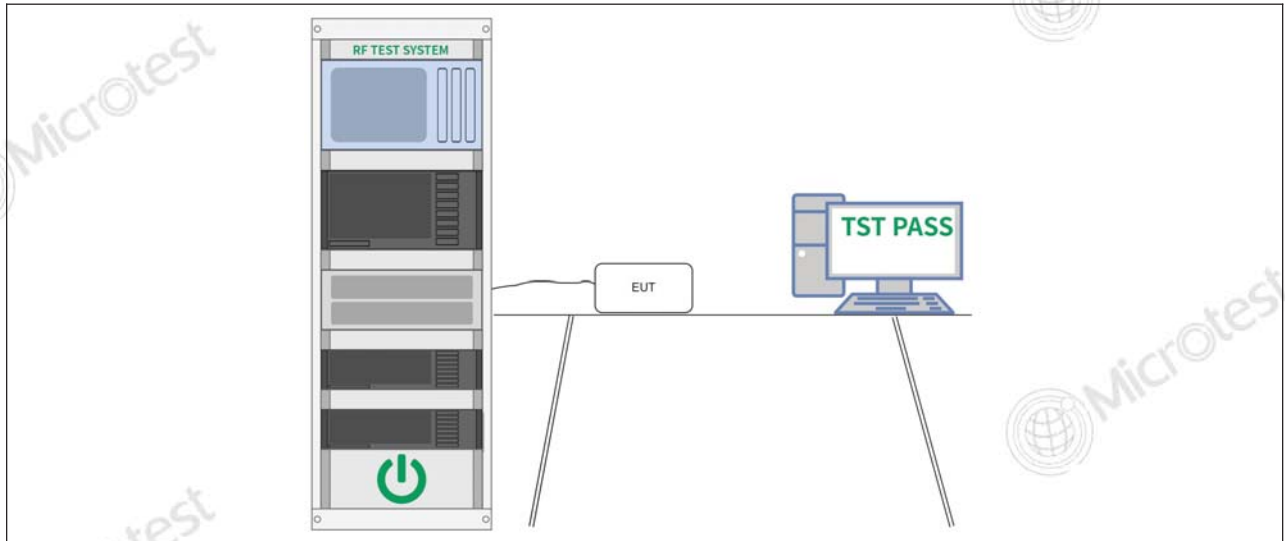

6.5.3 Test Data:

Please Refer to Appendix for Details.

TEST REPORT

Report No.: MTi250319006-0104E1

6.6 RF conducted spurious emissions and band edge measurement

| | |
|-------------------|---|
| Test Requirement: | 47 CFR 15.247(d) |
| Test Limit: | Refer to 47 CFR 15.247(d), In any 100 kHz bandwidth outside the frequency band in which the spread spectrum or digitally modulated intentional radiator is operating, the radio frequency power that is produced by the intentional radiator shall be at least 20 dB below that in the 100 kHz bandwidth within the band that contains the highest level of the desired power, based on either an RF conducted or a radiated measurement, provided the transmitter demonstrates compliance with the peak conducted power limits. If the transmitter complies with the conducted power limits based on the use of RMS averaging over a time interval, as permitted under paragraph (b)(3) of this section, the attenuation required under this paragraph shall be 30 dB instead of 20 dB. Attenuation below the general limits specified in § 15.209(a) is not required. |
| Test Method: | ANSI C63.10-2013 section 7.8.8 KDB 558074 D01 15.247 Meas Guidance v05r02 |
| Procedure: | Conducted spurious emissions shall be measured for the transmit frequency, per 5.5 and 5.6, and at the maximum transmit powers. Connect the primary antenna port through an attenuator to the spectrum analyzer input; in the results, account for all losses between the unlicensed wireless device output and the spectrum analyzer. The instrument shall span 30 MHz to 10 times the operating frequency in GHz, with a resolution bandwidth of 100 kHz, video bandwidth of 300 kHz, and a coupled sweep time with a peak detector. The band 30 MHz to the highest frequency may be split into smaller spans, as long as the entire spectrum is covered. |

6.6.1 E.U.T. Operation:

| | | | | | |
|------------------------|----------------------------|-----------|------|-----------------------|---------|
| Operating Environment: | | | | | |
| Temperature: | 25.1 °C | Humidity: | 59 % | Atmospheric Pressure: | 101 kPa |
| Pre test mode: | Mode1, Mode2, Mode3, Mode4 | | | | |
| Final test mode: | Mode1, Mode2, Mode3, Mode4 | | | | |

6.6.2 Test Setup Diagram:

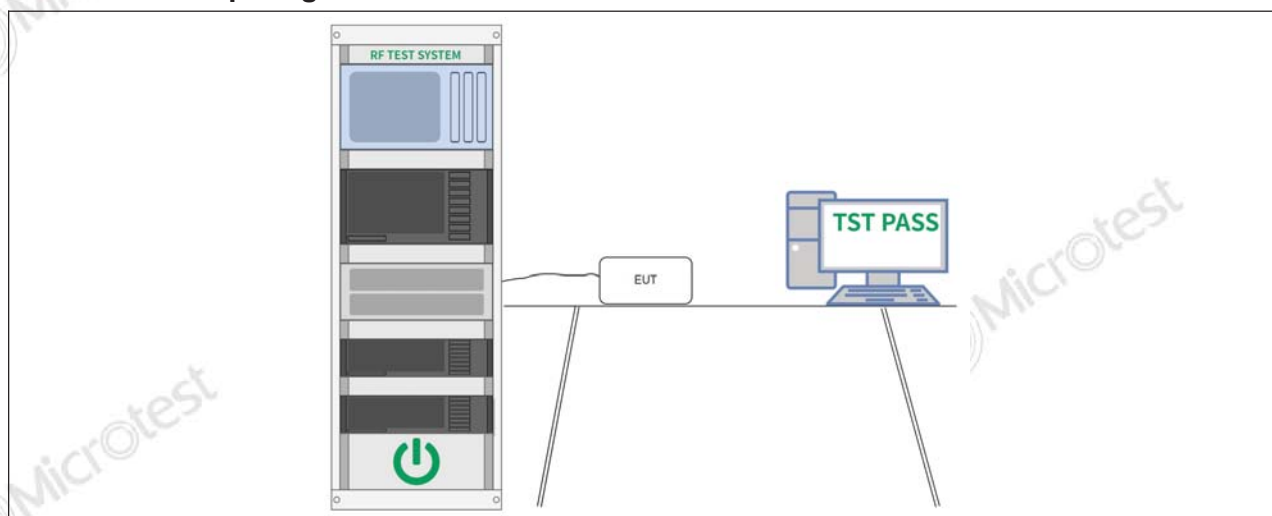

6.6.3 Test Data:

Please Refer to Appendix for Details.

TEST REPORT

Report No.: MTi250319006-0104E1

6.7 Band edge emissions (Radiated)

| | | | |
|--|--|-----------------------------------|-------------------------------|
| Test Requirement: | Refer to 47 CFR 15.247(d), In addition, radiated emissions which fall in the restricted bands, as defined in § 15.205(a), must also comply with the radiated emission limits specified in § 15.209(a)(see § 15.205(c)).` | | |
| Test Limit: | Frequency (MHz) | Field strength (microvolts/meter) | Measurement distance (meters) |
| | 0.009-0.490 | 2400/F(kHz) | 300 |
| | 0.490-1.705 | 24000/F(kHz) | 30 |
| | 1.705-30.0 | 30 | 30 |
| | 30-88 | 100 ** | 3 |
| | 88-216 | 150 ** | 3 |
| | 216-960 | 200 ** | 3 |
| | Above 960 | 500 | 3 |
| <p>** Except as provided in paragraph (g), fundamental emissions from intentional radiators operating under this section shall not be located in the frequency bands 54-72 MHz, 76-88 MHz, 174-216 MHz or 470-806 MHz. However, operation within these frequency bands is permitted under other sections of this part, e.g., §§ 15.231 and 15.241.</p> <p>In the emission table above, the tighter limit applies at the band edges. The emission limits shown in the above table are based on measurements employing a CISPR quasi-peak detector except for the frequency bands 9–90 kHz, 110–490 kHz and above 1000 MHz. Radiated emission limits in these three bands are based on measurements employing an average detector.</p> | | | |
| Test Method: | ANSI C63.10-2013 section 6.10 KDB 558074 D01 15.247 Meas Guidance v05r02 | | |
| Procedure: | ANSI C63.10-2013 section 6.10.5.2 | | |

6.7.1 E.U.T. Operation:

| | | | | | |
|--|---|-----------|--------|-----------------------|----------|
| Operating Environment: | | | | | |
| Temperature: | 19.3 °C | Humidity: | 45.1 % | Atmospheric Pressure: | 99.6 kPa |
| Pre test mode: | Mode1, Mode2, Mode3, Mode4 | | | | |
| Final test mode: | All of the listed pre-test mode were tested, only the data of the worst mode (Mode3, Mode4) is recorded in the report | | | | |
| Note: The amplitude of spurious emissions which are attenuated more than 20 dB below the limits are not reported. | | | | | |

6.7.2 Test Setup Diagram:

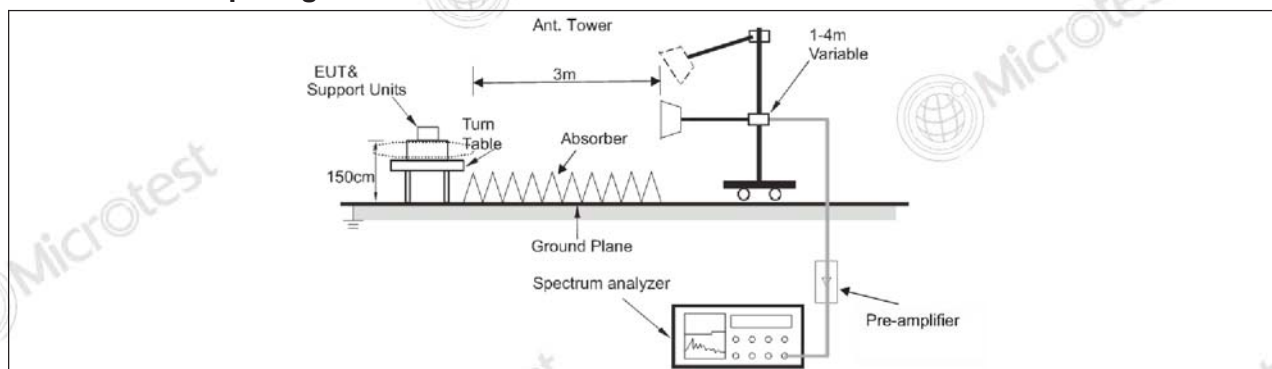

TEST REPORT

Report No.: MTi250319006-0104E1

6.7.3 Test Data:

Mode3 / Polarization: Horizontal / CH: L

| No. | Mk. | Freq. | Reading Level | Correct Factor | Measurement | Limit | Over | Detector |
|-----|-----|----------|---------------|----------------|-------------|--------|--------|----------|
| | | MHz | dBuV | dB | dBuV/m | dBuV/m | dB | |
| 1 | | 2310.000 | 47.48 | -4.37 | 43.11 | 74.00 | -30.89 | peak |
| 2 | | 2310.000 | 38.38 | -4.37 | 34.01 | 54.00 | -19.99 | AVG |
| 3 | | 2390.000 | 48.24 | -4.17 | 44.07 | 74.00 | -29.93 | peak |
| 4 | * | 2390.000 | 38.31 | -4.17 | 34.14 | 54.00 | -19.86 | AVG |

Mode3 / Polarization: Vertical / CH: L

| No. | Mk. | Freq. | Reading Level | Correct Factor | Measurement | Limit | Over | Detector |
|-----|-----|----------|---------------|----------------|-------------|--------|--------|----------|
| | | MHz | dBuV | dB | dBuV/m | dBuV/m | dB | |
| 1 | | 2310.000 | 49.12 | -4.37 | 44.75 | 74.00 | -29.25 | peak |
| 2 | | 2310.000 | 38.23 | -4.37 | 33.86 | 54.00 | -20.14 | AVG |
| 3 | | 2390.000 | 47.82 | -4.17 | 43.65 | 74.00 | -30.35 | peak |
| 4 | * | 2390.000 | 38.35 | -4.17 | 34.18 | 54.00 | -19.82 | AVG |

TEST REPORT

Report No.: MTi250319006-0104E1

Mode3 / Polarization: Horizontal / CH: H

| No. | Mk. | Freq. | Reading Level | Correct Factor | Measurement | Limit | Over | Detector |
|-----|-----|----------|---------------|----------------|-------------|--------|--------|----------|
| | | MHz | dBuV | dB | dBuV/m | dBuV/m | dB | |
| 1 | | 2483.500 | 48.76 | -4.08 | 44.68 | 74.00 | -29.32 | peak |
| 2 | * | 2483.500 | 38.82 | -4.08 | 34.74 | 54.00 | -19.26 | AVG |
| 3 | | 2500.000 | 49.30 | -4.00 | 45.30 | 74.00 | -28.70 | peak |
| 4 | | 2500.000 | 38.62 | -4.00 | 34.62 | 54.00 | -19.38 | AVG |

Mode3 / Polarization: Vertical / CH: H

| No. | Mk. | Freq. | Reading Level | Correct Factor | Measurement | Limit | Over | Detector |
|-----|-----|----------|---------------|----------------|-------------|--------|--------|----------|
| | | MHz | dBuV | dB | dBuV/m | dBuV/m | dB | |
| 1 | | 2483.500 | 50.10 | -4.08 | 46.02 | 74.00 | -27.98 | peak |
| 2 | | 2483.500 | 38.59 | -4.08 | 34.51 | 54.00 | -19.49 | AVG |
| 3 | | 2500.000 | 48.11 | -4.00 | 44.11 | 74.00 | -29.89 | peak |
| 4 | * | 2500.000 | 38.72 | -4.00 | 34.72 | 54.00 | -19.28 | AVG |

TEST REPORT

Report No.: MTi250319006-0104E1

Mode4 / Polarization: Horizontal / CH: L

| No. | Mk. | Freq. | Reading Level | Correct Factor | Measurement | Limit | Over | Detector |
|-----|-----|----------|---------------|----------------|-------------|--------|--------|----------|
| | | MHz | dBuV | dB | dBuV/m | dBuV/m | dB | |
| 1 | | 2310.000 | 48.05 | -4.37 | 43.68 | 74.00 | -30.32 | peak |
| 2 | | 2310.000 | 38.26 | -4.37 | 33.89 | 54.00 | -20.11 | AVG |
| 3 | | 2390.000 | 49.64 | -4.17 | 45.47 | 74.00 | -28.53 | peak |
| 4 | * | 2390.000 | 39.01 | -4.17 | 34.84 | 54.00 | -19.16 | AVG |

Mode4 / Polarization: Vertical / CH: L

| No. | Mk. | Freq. | Reading Level | Correct Factor | Measurement | Limit | Over | Detector |
|-----|-----|----------|---------------|----------------|-------------|--------|--------|----------|
| | | MHz | dBuV | dB | dBuV/m | dBuV/m | dB | |
| 1 | | 2310.000 | 48.38 | -4.37 | 44.01 | 74.00 | -29.99 | peak |
| 2 | | 2310.000 | 38.30 | -4.37 | 33.93 | 54.00 | -20.07 | AVG |
| 3 | | 2390.000 | 48.60 | -4.17 | 44.43 | 74.00 | -29.57 | peak |
| 4 | * | 2390.000 | 38.32 | -4.17 | 34.15 | 54.00 | -19.85 | AVG |

TEST REPORT

Report No.: MTi250319006-0104E1

Mode4 / Polarization: Horizontal / CH: H

| No. | Mk. | Freq. | Reading Level | Correct Factor | Measurement | Limit | Over | Detector |
|-----|-----|----------|---------------|----------------|-------------|--------|--------|----------|
| | | MHz | dBuV | dB | dBuV/m | dBuV/m | dB | |
| 1 | | 2483.500 | 51.42 | -4.08 | 47.34 | 74.00 | -26.66 | peak |
| 2 | * | 2483.500 | 40.09 | -4.08 | 36.01 | 54.00 | -17.99 | AVG |
| 3 | | 2500.000 | 50.35 | -4.00 | 46.35 | 74.00 | -27.65 | peak |
| 4 | | 2500.000 | 39.67 | -4.00 | 35.67 | 54.00 | -18.33 | AVG |

Mode4 / Polarization: Vertical / CH: H

| No. | Mk. | Freq. | Reading Level | Correct Factor | Measurement | Limit | Over | Detector |
|-----|-----|----------|---------------|----------------|-------------|--------|--------|----------|
| | | MHz | dBuV | dB | dBuV/m | dBuV/m | dB | |
| 1 | | 2483.500 | 48.77 | -4.08 | 44.69 | 74.00 | -29.31 | peak |
| 2 | * | 2483.500 | 38.67 | -4.08 | 34.59 | 54.00 | -19.41 | AVG |
| 3 | | 2500.000 | 48.73 | -4.00 | 44.73 | 74.00 | -29.27 | peak |
| 4 | | 2500.000 | 38.58 | -4.00 | 34.58 | 54.00 | -19.42 | AVG |

TEST REPORT

Report No.: MTI250319006-0104E1

6.8 Radiated emissions (below 1GHz)

| | | | |
|---|--|-----------------------------------|-------------------------------|
| Test Requirement: | Refer to 47 CFR 15.247(d), In addition, radiated emissions which fall in the restricted bands, as defined in § 15.205(a), must also comply with the radiated emission limits specified in § 15.209(a)(see § 15.205(c)).` | | |
| Test Limit: | Frequency (MHz) | Field strength (microvolts/meter) | Measurement distance (meters) |
| | 0.009-0.490 | 2400/F(kHz) | 300 |
| | 0.490-1.705 | 24000/F(kHz) | 30 |
| | 1.705-30.0 | 30 | 30 |
| | 30-88 | 100 ** | 3 |
| | 88-216 | 150 ** | 3 |
| | 216-960 | 200 ** | 3 |
| | Above 960 | 500 | 3 |
| <p>** Except as provided in paragraph (g), fundamental emissions from intentional radiators operating under this section shall not be located in the frequency bands 54-72 MHz, 76-88 MHz, 174-216 MHz or 470-806 MHz. However, operation within these frequency bands is permitted under other sections of this part, e.g., §§ 15.231 and 15.241.</p> <p>In the emission table above, the tighter limit applies at the band edges.</p> <p>The emission limits shown in the above table are based on measurements employing a CISPR quasi-peak detector except for the frequency bands 9–90 kHz, 110–490 kHz and above 1000 MHz. Radiated emission limits in these three bands are based on measurements employing an average detector.</p> | | | |
| Test Method: | ANSI C63.10-2013 section 6.6.4 KDB 558074 D01 15.247 Meas Guidance v05r02 | | |
| Procedure: | ANSI C63.10-2013 section 6.6.4 | | |

6.8.1 E.U.T. Operation:

| | | | |
|---|---|-----------------------|----------|
| Operating Environment: | | | |
| Temperature: | 19.3 °C | Humidity: | 45.1 % |
| | | Atmospheric Pressure: | 99.6 kPa |
| Pre test mode: | Mode1, Mode2, Mode3, Mode4 | | |
| Final test mode: | All of the listed pre-test mode were tested, only the data of the worst mode (Mode3, Mode4) is recorded in the report | | |
| <p>Note:</p> <p>The amplitude of spurious emissions which are attenuated more than 20 dB below the limits are not reported.</p> <p>All modes of operation of the EUT were investigated, and only the worst-case results are reported. There were no emissions found below 30MHz within 20dB of the limit.</p> | | | |

6.8.2 Test Setup Diagram:

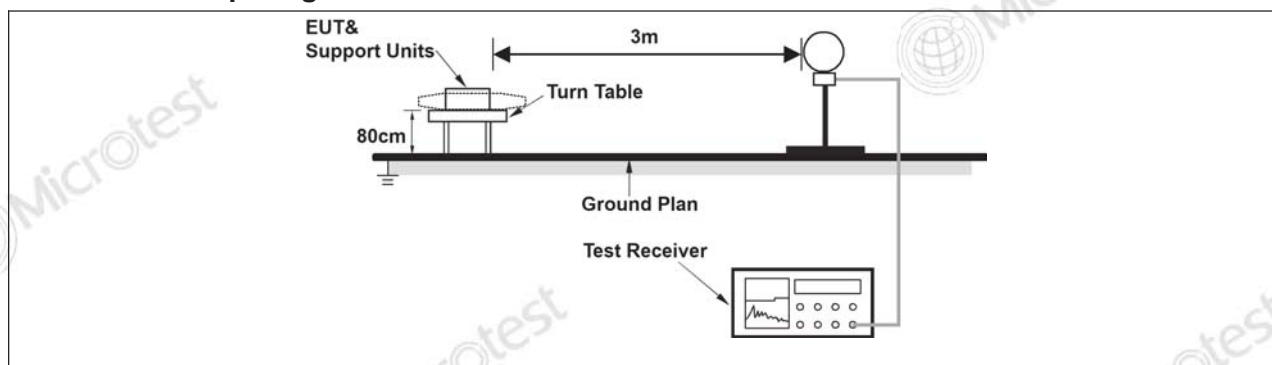

TEST REPORT

Report No.: MTi250319006-0104E1

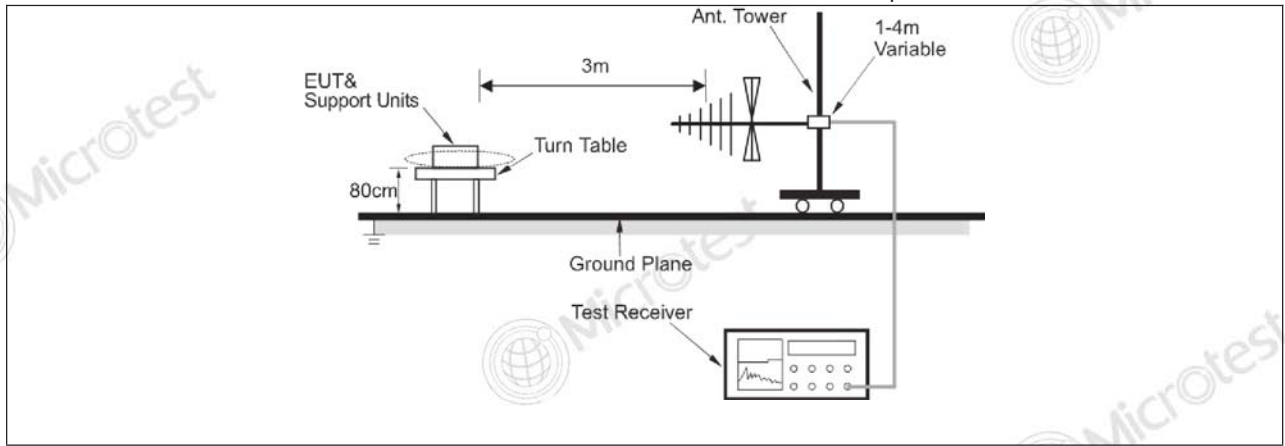

TEST REPORT

Report No.: MTi250319006-0104E1

6.8.3 Test Data:

Mode3 / Polarization: Horizontal / CH: H

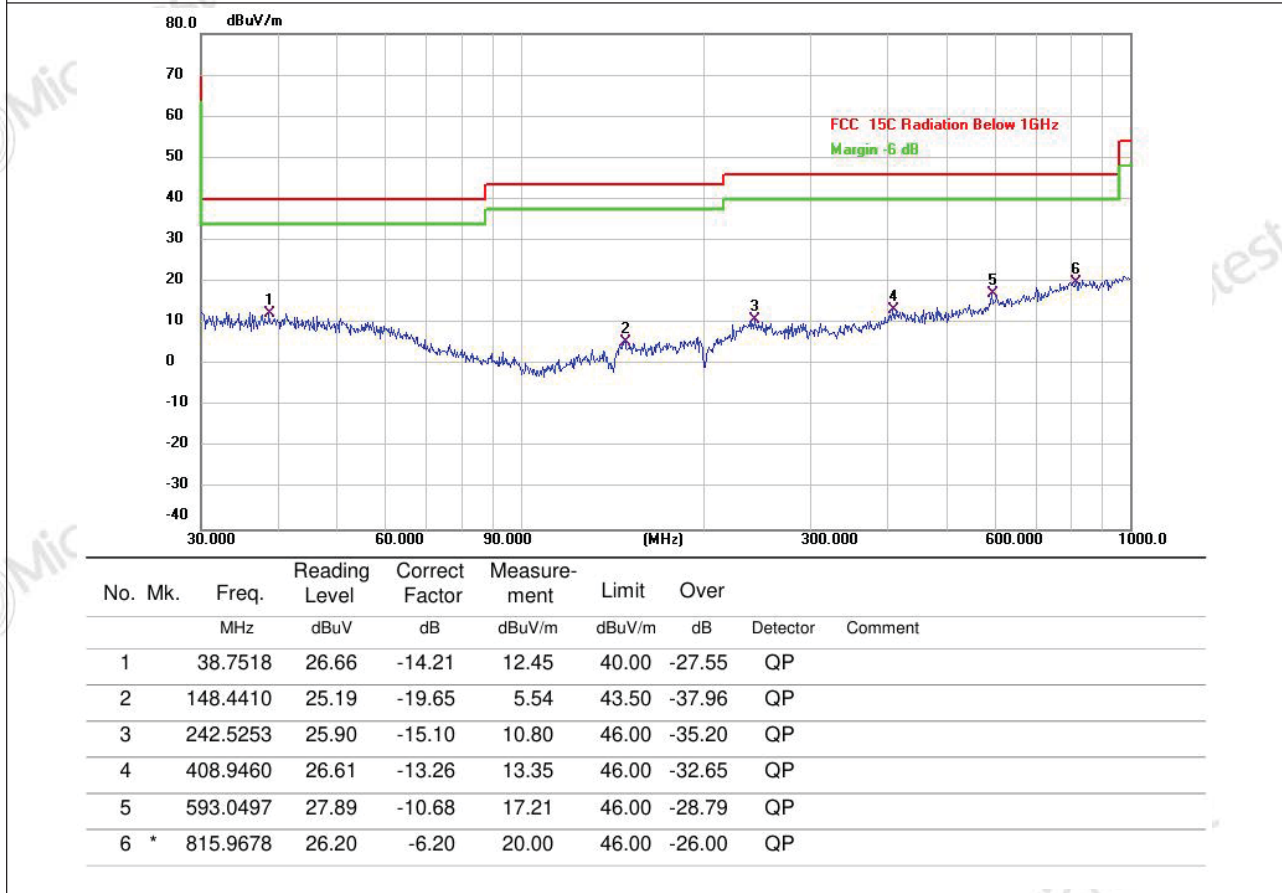

TEST REPORT

Report No.: MTI250319006-0104E1

Mode3 / Polarization: Vertical / CH: H

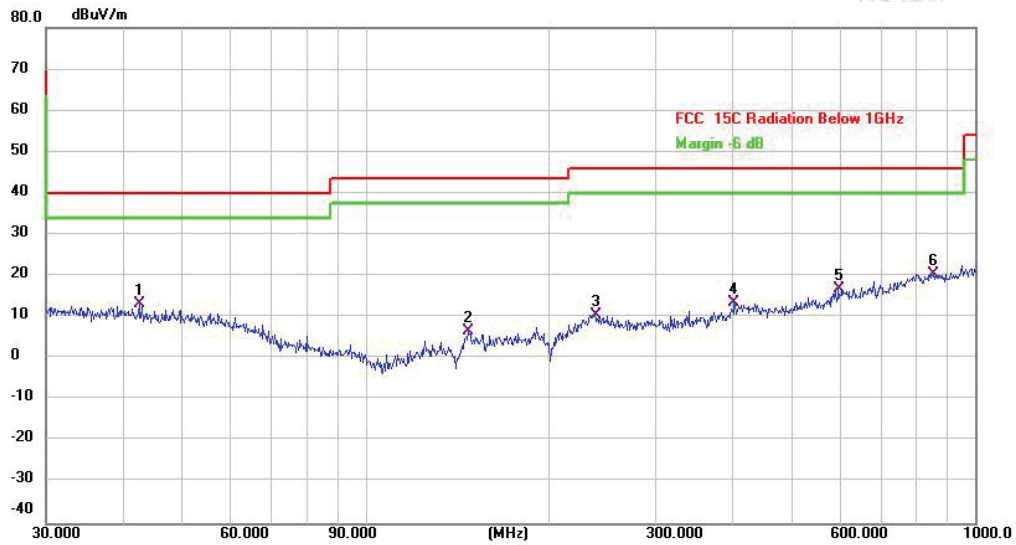

| No. Mk. | Freq. MHz | Reading Level dBuV | Correct Factor dB | Measurement dBuV/m | Limit dBuV/m | Over dB | Detector | Comment |
|---------|-----------|--------------------|-------------------|--------------------|--------------|---------|----------|---------|
| 1 | 42.6000 | 37.62 | -24.24 | 13.38 | 40.00 | -26.62 | QP | |
| 2 | 147.4036 | 22.39 | -15.77 | 6.62 | 43.50 | -36.88 | QP | |
| 3 | 238.3102 | 30.05 | -19.39 | 10.66 | 46.00 | -35.34 | QP | |
| 4 | 403.2500 | 27.35 | -13.92 | 13.43 | 46.00 | -32.57 | QP | |
| 5 | 597.2234 | 27.54 | -10.68 | 16.86 | 46.00 | -29.14 | QP | |
| 6 * | 854.0247 | 27.66 | -7.16 | 20.50 | 46.00 | -25.50 | QP | |

TEST REPORT

Report No.: MTI250319006-0104E1

Mode4 / Polarization: Horizontal / CH: H

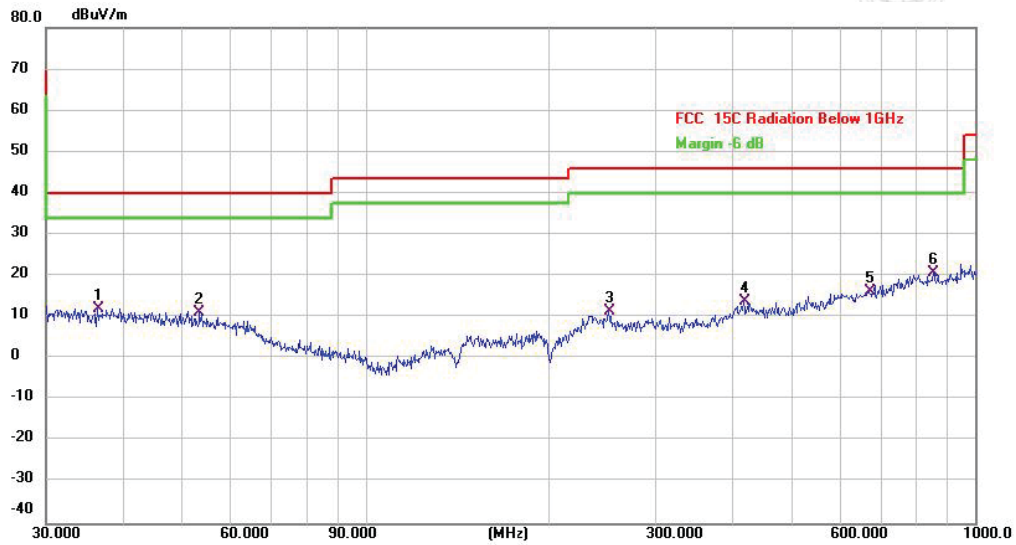

| No. Mk. | Freq. MHz | Reading Level dBuV | Correct Factor dB | Measurement dBuV/m | Limit dBuV/m | Over dB | Detector | Comment |
|---------|-----------|--------------------|-------------------|--------------------|--------------|---------|----------|---------|
| 1 | 36.3814 | 36.68 | -24.52 | 12.16 | 40.00 | -27.84 | QP | |
| 2 | 53.5052 | 32.67 | -21.64 | 11.03 | 40.00 | -28.97 | QP | |
| 3 | 251.1804 | 29.35 | -17.96 | 11.39 | 46.00 | -34.61 | QP | |
| 4 | 417.6411 | 28.27 | -14.28 | 13.99 | 46.00 | -32.01 | QP | |
| 5 | 670.4893 | 25.45 | -9.14 | 16.31 | 46.00 | -29.69 | QP | |
| 6 * | 854.0247 | 27.80 | -7.16 | 20.64 | 46.00 | -25.36 | QP | |

TEST REPORT

Report No.: MTI250319006-0104E1

Mode4 / Polarization: Vertical / CH: H

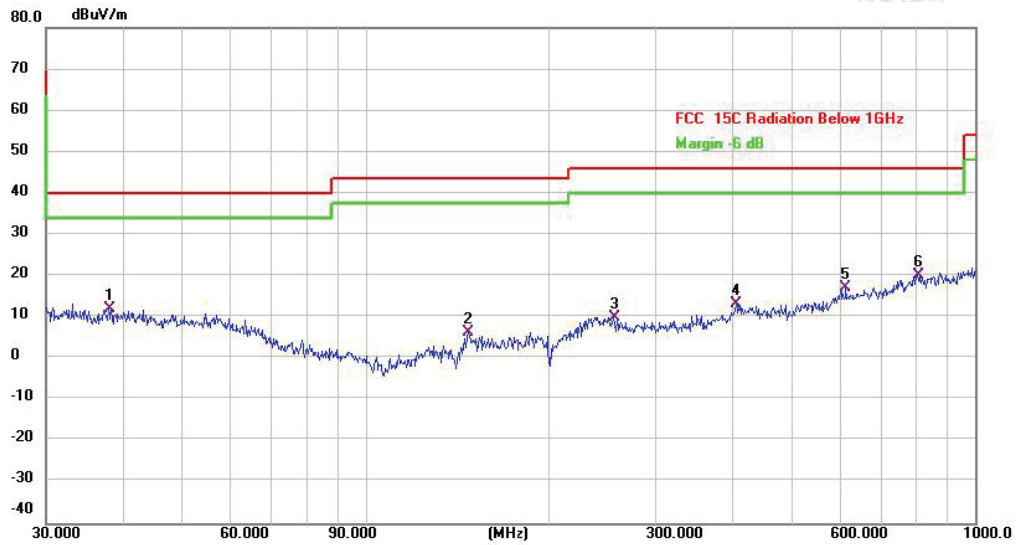

| No. | Mk. | Freq. MHz | Reading Level dBuV | Correct Factor dB | Measure- ment dBuV/m | Limit dBuV/m | Over dB | Detector | Comment |
|-----|-----|--------------|--------------------------|-------------------------|----------------------------|-----------------|------------|----------|---------|
| 1 | | 37.9450 | 26.26 | -14.12 | 12.14 | 40.00 | -27.86 | QP | |
| 2 | | 147.4036 | 25.52 | -19.16 | 6.36 | 43.50 | -37.14 | QP | |
| 3 | | 255.6231 | 25.99 | -15.96 | 10.03 | 46.00 | -35.97 | QP | |
| 4 | | 406.0880 | 26.87 | -13.54 | 13.33 | 46.00 | -32.67 | QP | |
| 5 | | 614.2142 | 27.64 | -10.62 | 17.02 | 46.00 | -28.98 | QP | |
| 6 | * | 804.6028 | 25.92 | -5.87 | 20.05 | 46.00 | -25.95 | QP | |

TEST REPORT

Report No.: MTi250319006-0104E1

6.9 Radiated emissions (above 1GHz)

| | | | |
|-------------------|--|-----------------------------------|-------------------------------|
| Test Requirement: | Refer to 47 CFR 15.247(d), in addition, radiated emissions which fall in the restricted bands, as defined in § 15.205(a), must also comply with the radiated emission limits specified in § 15.209(a)(see § 15.205(c)). | | |
| Test Limit: | Frequency (MHz) | Field strength (microvolts/meter) | Measurement distance (meters) |
| | 0.009-0.490 | 2400/F(kHz) | 300 |
| | 0.490-1.705 | 24000/F(kHz) | 30 |
| | 1.705-30.0 | 30 | 30 |
| | 30-88 | 100 ** | 3 |
| | 88-216 | 150 ** | 3 |
| | 216-960 | 200 ** | 3 |
| | Above 960 | 500 | 3 |
| | ** Except as provided in paragraph (g), fundamental emissions from intentional radiators operating under this section shall not be located in the frequency bands 54-72 MHz, 76-88 MHz, 174-216 MHz or 470-806 MHz. However, operation within these frequency bands is permitted under other sections of this part, e.g., §§ 15.231 and 15.241. In the emission table above, the tighter limit applies at the band edges. The emission limits shown in the above table are based on measurements employing a CISPR quasi-peak detector except for the frequency bands 9–90 kHz, 110–490 kHz and above 1000 MHz. Radiated emission limits in these three bands are based on measurements employing an average detector. | | |
| Test Method: | ANSI C63.10-2013 section 6.6.4 KDB 558074 D01 15.247 Meas Guidance v05r02 | | |
| Procedure: | ANSI C63.10-2013 section 6.6.4 | | |

6.9.1 E.U.T. Operation:

| | | | |
|--|---|-----------------------|----------|
| Operating Environment: | | | |
| Temperature: | 25 °C | Humidity: | 45.1 % |
| | | Atmospheric Pressure: | 99.6 kPa |
| Pre test mode: | Mode1, Mode2, Mode3, Mode4 | | |
| Final test mode: | All of the listed pre-test mode were tested, only the data of the worst mode (Mode3, Mode4) is recorded in the report | | |
| Note: Test frequency are from 1GHz to 25GHz, the amplitude of spurious emissions which are attenuated more than 20 dB below the limits are not reported. All modes of operation of the EUT were investigated, and only the worst-case results are reported. | | | |

6.9.2 Test Setup Diagram:

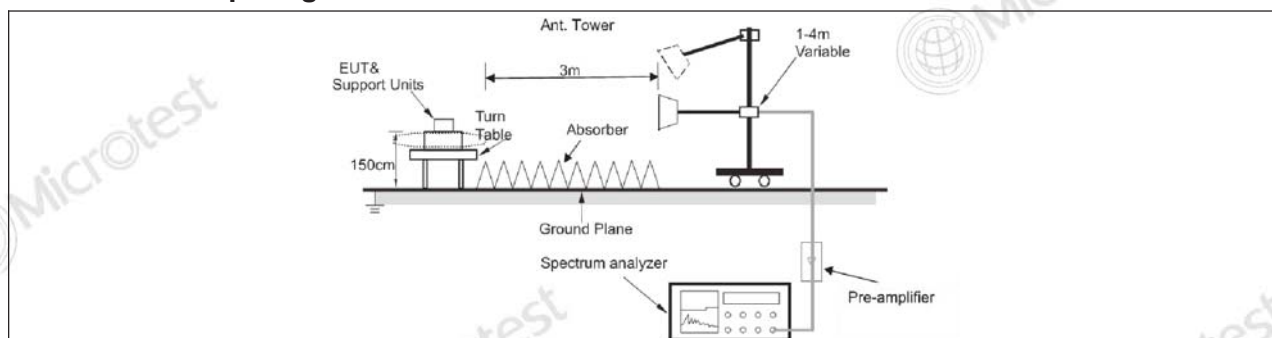

TEST REPORT

Report No.: MTi250319006-0104E1

6.9.3 Test Data:

Mode3 / Polarization: Horizontal / CH: L

| No. | Mk. | Freq. | Reading Level | Correct Factor | Measurement | Limit | Over | Detector |
|-----|-----|----------|---------------|----------------|-------------|--------|--------|----------|
| | | MHz | dBuV | dB | dBuV/m | dBuV/m | dB | |
| 1 | | 4804.000 | 48.47 | 1.76 | 50.23 | 74.00 | -23.77 | peak |
| 2 | | 4804.000 | 43.51 | 1.76 | 45.27 | 54.00 | -8.73 | AVG |
| 3 | | 7206.000 | 47.35 | 7.45 | 54.80 | 74.00 | -19.20 | peak |
| 4 | | 7206.000 | 42.69 | 7.45 | 50.14 | 54.00 | -3.86 | AVG |
| 5 | | 9608.000 | 48.25 | 8.78 | 57.03 | 74.00 | -16.97 | peak |
| 6 | * | 9608.000 | 42.17 | 8.78 | 50.95 | 54.00 | -3.05 | AVG |

Mode3 / Polarization: Vertical / CH: L

| No. | Mk. | Freq. | Reading Level | Correct Factor | Measurement | Limit | Over | Detector |
|-----|-----|----------|---------------|----------------|-------------|--------|--------|----------|
| | | MHz | dBuV | dB | dBuV/m | dBuV/m | dB | |
| 1 | | 4804.000 | 43.93 | 1.76 | 45.69 | 74.00 | -28.31 | peak |
| 2 | | 4804.000 | 38.39 | 1.76 | 40.15 | 54.00 | -13.85 | AVG |
| 3 | | 7206.000 | 45.99 | 7.45 | 53.44 | 74.00 | -20.56 | peak |
| 4 | | 7206.000 | 41.92 | 7.45 | 49.37 | 54.00 | -4.63 | AVG |
| 5 | | 9608.000 | 45.39 | 8.78 | 54.17 | 74.00 | -19.83 | peak |
| 6 | * | 9608.000 | 41.46 | 8.78 | 50.24 | 54.00 | -3.76 | AVG |

TEST REPORT

Report No.: MTi250319006-0104E1

Mode3 / Polarization: Horizontal / CH: M

| No. | Mk. | Freq. | Reading Level | Correct Factor | Measurement | Limit | Over | Detector |
|-----|-----|----------|---------------|----------------|-------------|--------|--------|----------|
| | | MHz | dBuV | dB | dBuV/m | dBuV/m | dB | |
| 1 | | 4882.000 | 49.18 | 2.20 | 51.38 | 74.00 | -22.62 | peak |
| 2 | | 4882.000 | 43.07 | 2.20 | 45.27 | 54.00 | -8.73 | AVG |
| 3 | | 7323.000 | 44.43 | 7.87 | 52.30 | 74.00 | -21.70 | peak |
| 4 | | 7323.000 | 41.45 | 7.87 | 49.32 | 54.00 | -4.68 | AVG |
| 5 | | 9764.000 | 46.75 | 9.40 | 56.15 | 74.00 | -17.85 | peak |
| 6 | * | 9764.000 | 40.88 | 9.40 | 50.28 | 54.00 | -3.72 | AVG |

Mode3 / Polarization: Vertical / CH: M

| No. | Mk. | Freq. | Reading Level | Correct Factor | Measurement | Limit | Over | Detector |
|-----|-----|----------|---------------|----------------|-------------|--------|--------|----------|
| | | MHz | dBuV | dB | dBuV/m | dBuV/m | dB | |
| 1 | | 4882.000 | 44.83 | 2.20 | 47.03 | 74.00 | -26.97 | peak |
| 2 | | 4882.000 | 40.38 | 2.20 | 42.58 | 54.00 | -11.42 | AVG |
| 3 | | 7323.000 | 44.63 | 7.87 | 52.50 | 74.00 | -21.50 | peak |
| 4 | | 7323.000 | 41.81 | 7.87 | 49.68 | 54.00 | -4.32 | AVG |
| 5 | | 9764.000 | 45.78 | 9.40 | 55.18 | 74.00 | -18.82 | peak |
| 6 | * | 9764.000 | 40.77 | 9.40 | 50.17 | 54.00 | -3.83 | AVG |

TEST REPORT

Report No.: MTi250319006-0104E1

Mode3 / Polarization: Horizontal / CH: H

| No. | Mk. | Freq. | Reading Level | Correct Factor | Measurement | Limit | Over | Detector |
|-----|-----|----------|---------------|----------------|-------------|--------|--------|----------|
| | | MHz | dBuV | dB | dBuV/m | dBuV/m | dB | |
| 1 | | 4960.000 | 47.79 | 2.66 | 50.45 | 74.00 | -23.55 | peak |
| 2 | | 4960.000 | 42.73 | 2.66 | 45.39 | 54.00 | -8.61 | AVG |
| 3 | | 7440.000 | 46.09 | 7.80 | 53.89 | 74.00 | -20.11 | peak |
| 4 | | 7440.000 | 41.92 | 7.80 | 49.72 | 54.00 | -4.28 | AVG |
| 5 | | 9920.000 | 46.86 | 9.29 | 56.15 | 74.00 | -17.85 | peak |
| 6 | * | 9920.000 | 40.88 | 9.29 | 50.17 | 54.00 | -3.83 | AVG |

Mode3 / Polarization: Vertical / CH: H

| No. | Mk. | Freq. | Reading Level | Correct Factor | Measurement | Limit | Over | Detector |
|-----|-----|----------|---------------|----------------|-------------|--------|--------|----------|
| | | MHz | dBuV | dB | dBuV/m | dBuV/m | dB | |
| 1 | | 4960.000 | 44.73 | 2.66 | 47.39 | 74.00 | -26.61 | peak |
| 2 | | 4960.000 | 39.85 | 2.66 | 42.51 | 54.00 | -11.49 | AVG |
| 3 | | 7440.000 | 45.49 | 7.80 | 53.29 | 74.00 | -20.71 | peak |
| 4 | * | 7440.000 | 41.85 | 7.80 | 49.65 | 54.00 | -4.35 | AVG |
| 5 | | 9920.000 | 45.68 | 9.29 | 54.97 | 74.00 | -19.03 | peak |
| 6 | | 9920.000 | 39.43 | 9.29 | 48.72 | 54.00 | -5.28 | AVG |

TEST REPORT

Report No.: MTi250319006-0104E1

Mode4 / Polarization: Horizontal / CH: L

| No. | Mk. | Freq. | Reading Level | Correct Factor | Measurement | Limit | Over | Detector |
|-----|-----|----------|---------------|----------------|-------------|--------|--------|----------|
| | | MHz | dBuV | dB | dBuV/m | dBuV/m | dB | |
| 1 | | 4804.000 | 45.40 | 1.76 | 47.16 | 74.00 | -26.84 | peak |
| 2 | | 4804.000 | 40.78 | 1.76 | 42.54 | 54.00 | -11.46 | AVG |
| 3 | | 7206.000 | 43.36 | 7.45 | 50.81 | 74.00 | -23.19 | peak |
| 4 | | 7206.000 | 37.94 | 7.45 | 45.39 | 54.00 | -8.61 | AVG |
| 5 | | 9608.000 | 44.86 | 8.78 | 53.64 | 74.00 | -20.36 | peak |
| 6 | * | 9608.000 | 40.96 | 8.78 | 49.74 | 54.00 | -4.26 | AVG |

Mode4 / Polarization: Vertical / CH: L

| No. | Mk. | Freq. | Reading Level | Correct Factor | Measurement | Limit | Over | Detector |
|-----|-----|----------|---------------|----------------|-------------|--------|--------|----------|
| | | MHz | dBuV | dB | dBuV/m | dBuV/m | dB | |
| 1 | | 4804.000 | 48.06 | 1.76 | 49.82 | 74.00 | -24.18 | peak |
| 2 | | 4804.000 | 43.38 | 1.76 | 45.14 | 54.00 | -8.86 | AVG |
| 3 | | 7206.000 | 44.13 | 7.45 | 51.58 | 74.00 | -22.42 | peak |
| 4 | | 7206.000 | 38.80 | 7.45 | 46.25 | 54.00 | -7.75 | AVG |
| 5 | | 9608.000 | 45.41 | 8.78 | 54.19 | 74.00 | -19.81 | peak |
| 6 | * | 9608.000 | 40.94 | 8.78 | 49.72 | 54.00 | -4.28 | AVG |

TEST REPORT

Report No.: MTi250319006-0104E1

Mode4 / Polarization: Horizontal / CH: M

| No. | Mk. | Freq. | Reading Level | Correct Factor | Measurement | Limit | Over | Detector |
|-----|-----|----------|---------------|----------------|-------------|--------|--------|----------|
| | | MHz | dBuV | dB | dBuV/m | dBuV/m | dB | |
| 1 | | 4882.000 | 44.81 | 2.20 | 47.01 | 74.00 | -26.99 | peak |
| 2 | | 4882.000 | 40.38 | 2.20 | 42.58 | 54.00 | -11.42 | AVG |
| 3 | | 7323.000 | 43.51 | 7.87 | 51.38 | 74.00 | -22.62 | peak |
| 4 | | 7323.000 | 39.66 | 7.87 | 47.53 | 54.00 | -6.47 | AVG |
| 5 | | 9764.000 | 44.70 | 9.40 | 54.10 | 74.00 | -19.90 | peak |
| 6 | * | 9764.000 | 39.74 | 9.40 | 49.14 | 54.00 | -4.86 | AVG |

Mode4 / Polarization: Vertical / CH: M

| No. | Mk. | Freq. | Reading Level | Correct Factor | Measurement | Limit | Over | Detector |
|-----|-----|----------|---------------|----------------|-------------|--------|--------|----------|
| | | MHz | dBuV | dB | dBuV/m | dBuV/m | dB | |
| 1 | | 4882.000 | 48.72 | 2.20 | 50.92 | 74.00 | -23.08 | peak |
| 2 | | 4882.000 | 43.19 | 2.20 | 45.39 | 54.00 | -8.61 | AVG |
| 3 | | 7323.000 | 43.10 | 7.87 | 50.97 | 74.00 | -23.03 | peak |
| 4 | | 7323.000 | 38.00 | 7.87 | 45.87 | 54.00 | -8.13 | AVG |
| 5 | | 9764.000 | 43.94 | 9.40 | 53.34 | 74.00 | -20.66 | peak |
| 6 | * | 9764.000 | 39.81 | 9.40 | 49.21 | 54.00 | -4.79 | AVG |

TEST REPORT

Report No.: MTi250319006-0104E1

Mode4 / Polarization: Horizontal / CH: H

| No. | Mk. | Freq. | Reading Level | Correct Factor | Measurement | Limit | Over | Detector |
|-----|-----|----------|---------------|----------------|-------------|--------|--------|----------|
| | | MHz | dBuV | dB | dBuV/m | dBuV/m | dB | |
| 1 | | 4960.000 | 46.23 | 2.66 | 48.89 | 74.00 | -25.11 | peak |
| 2 | | 4960.000 | 42.61 | 2.66 | 45.27 | 54.00 | -8.73 | AVG |
| 3 | | 7440.000 | 43.59 | 7.80 | 51.39 | 74.00 | -22.61 | peak |
| 4 | | 7440.000 | 37.57 | 7.80 | 45.37 | 54.00 | -8.63 | AVG |
| 5 | | 9920.000 | 44.68 | 9.29 | 53.97 | 74.00 | -20.03 | peak |
| 6 | * | 9920.000 | 39.47 | 9.29 | 48.76 | 54.00 | -5.24 | AVG |

Mode4 / Polarization: Vertical / CH: H

| No. | Mk. | Freq. | Reading Level | Correct Factor | Measurement | Limit | Over | Detector |
|-----|-----|----------|---------------|----------------|-------------|--------|--------|----------|
| | | MHz | dBuV | dB | dBuV/m | dBuV/m | dB | |
| 1 | | 4960.000 | 47.33 | 2.66 | 49.99 | 74.00 | -24.01 | peak |
| 2 | | 4960.000 | 43.12 | 2.66 | 45.78 | 54.00 | -8.22 | AVG |
| 3 | | 7440.000 | 43.44 | 7.80 | 51.24 | 74.00 | -22.76 | peak |
| 4 | | 7440.000 | 38.49 | 7.80 | 46.29 | 54.00 | -7.71 | AVG |
| 5 | | 9920.000 | 44.60 | 9.29 | 53.89 | 74.00 | -20.11 | peak |
| 6 | * | 9920.000 | 40.46 | 9.29 | 49.75 | 54.00 | -4.25 | AVG |

TEST REPORT

Report No.: MTi250319006-0104E1

Photographs of the test setup

Refer to Appendix - Test Setup Photos

TEST REPORT

Report No.: MTi250319006-0104E1

Photographs of the EUT

Refer to Appendix - EUT Photos

Appendix

TEST REPORT

Report No.: MTi250319006-0104E1

Appendix A: 20dB Emission Bandwidth

Test Result

| Test Mode | Antenna | Frequency [MHz] | 20db EBW [MHz] |
|-----------|---------|-----------------|----------------|
| DH5 | Ant1 | 2402 | 1.008 |
| | Ant2 | 2402 | 1.023 |
| | Ant1 | 2441 | 0.954 |
| | Ant2 | 2441 | 0.966 |
| | Ant1 | 2480 | 0.981 |
| | Ant2 | 2480 | 0.975 |
| 2DH5 | Ant1 | 2402 | 1.335 |
| | Ant2 | 2402 | 1.326 |
| | Ant1 | 2441 | 1.374 |
| | Ant2 | 2441 | 1.323 |
| | Ant1 | 2480 | 1.344 |
| | Ant2 | 2480 | 1.323 |

TEST REPORT

Report No.: MTi250319006-0104E1

Test Graphs



TEST REPORT

Report No.: MTI250319006-0104E1



TEST REPORT

Report No.: MTI250319006-0104E1



TEST REPORT

Report No.: MTI250319006-0104E1



TEST REPORT

Report No.: MTI250319006-0104E1



TEST REPORT

Report No.: MTI250319006-0104E1

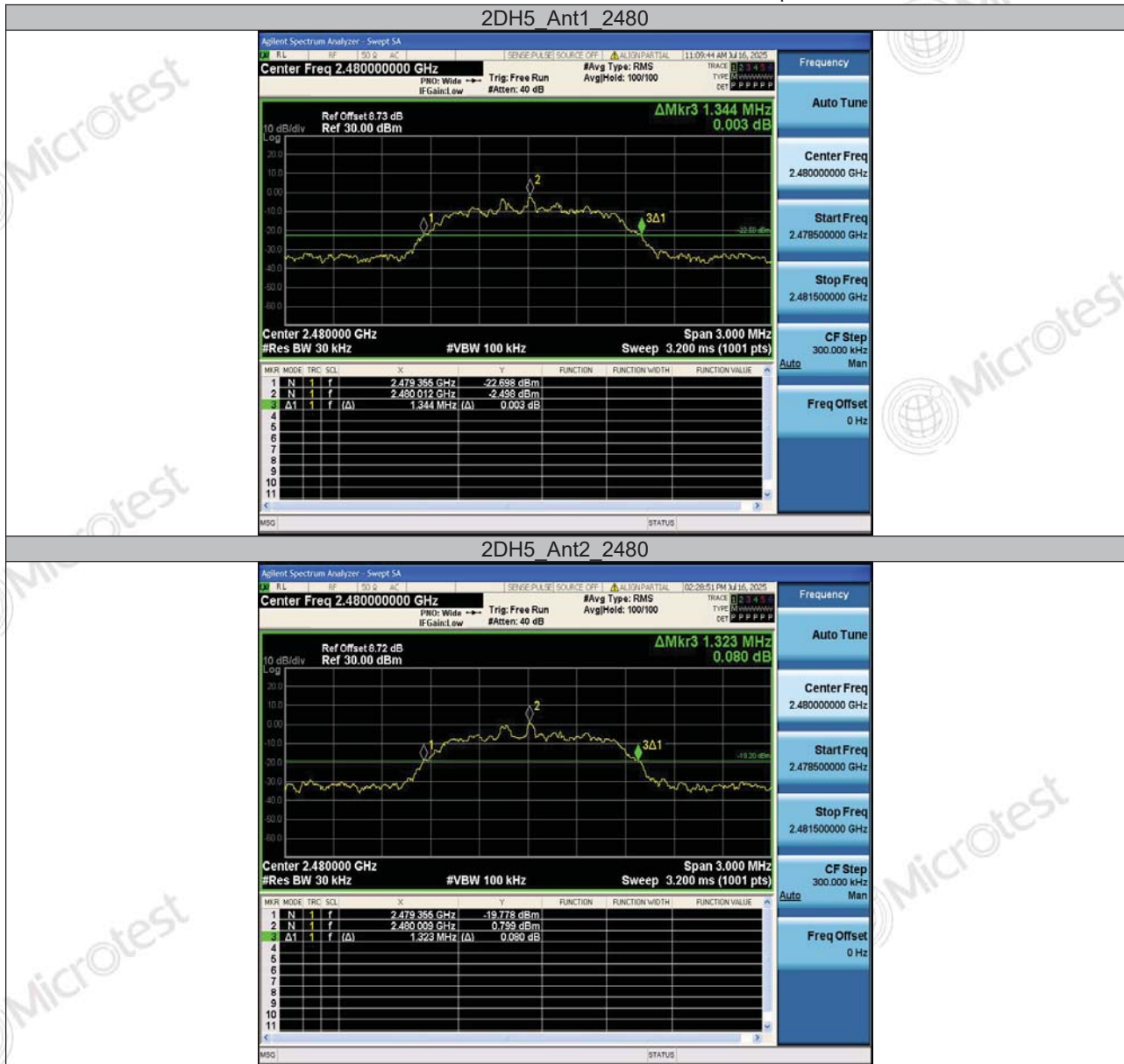

TEST REPORT

Report No.: MTi250319006-0104E1

Appendix B: Maximum conducted output power

Test Result Peak

| Test Mode | Antenna | Frequency [MHz] | Conducted Peak Power [dBm] | Limit [dBm] | Verdict |
|-----------|---------|-----------------|----------------------------|-------------|---------|
| DH5 | Ant1 | 2402 | 0.07 | ≤20.97 | PASS |
| | Ant2 | 2402 | 3.37 | ≤20.97 | PASS |
| | Ant1 | 2441 | 0.08 | ≤20.97 | PASS |
| | Ant2 | 2441 | 3.35 | ≤20.97 | PASS |
| | Ant1 | 2480 | 0.40 | ≤20.97 | PASS |
| | Ant2 | 2480 | 3.68 | ≤20.97 | PASS |
| 2DH5 | Ant1 | 2402 | 0.49 | ≤20.97 | PASS |
| | Ant2 | 2402 | 3.77 | ≤20.97 | PASS |
| | Ant1 | 2441 | 0.49 | ≤20.97 | PASS |
| | Ant2 | 2441 | 3.71 | ≤20.97 | PASS |
| | Ant1 | 2480 | 0.67 | ≤20.97 | PASS |
| | Ant2 | 2480 | 3.93 | ≤20.97 | PASS |

TEST REPORT

Report No.: MTI250319006-0104E1

Test Graphs

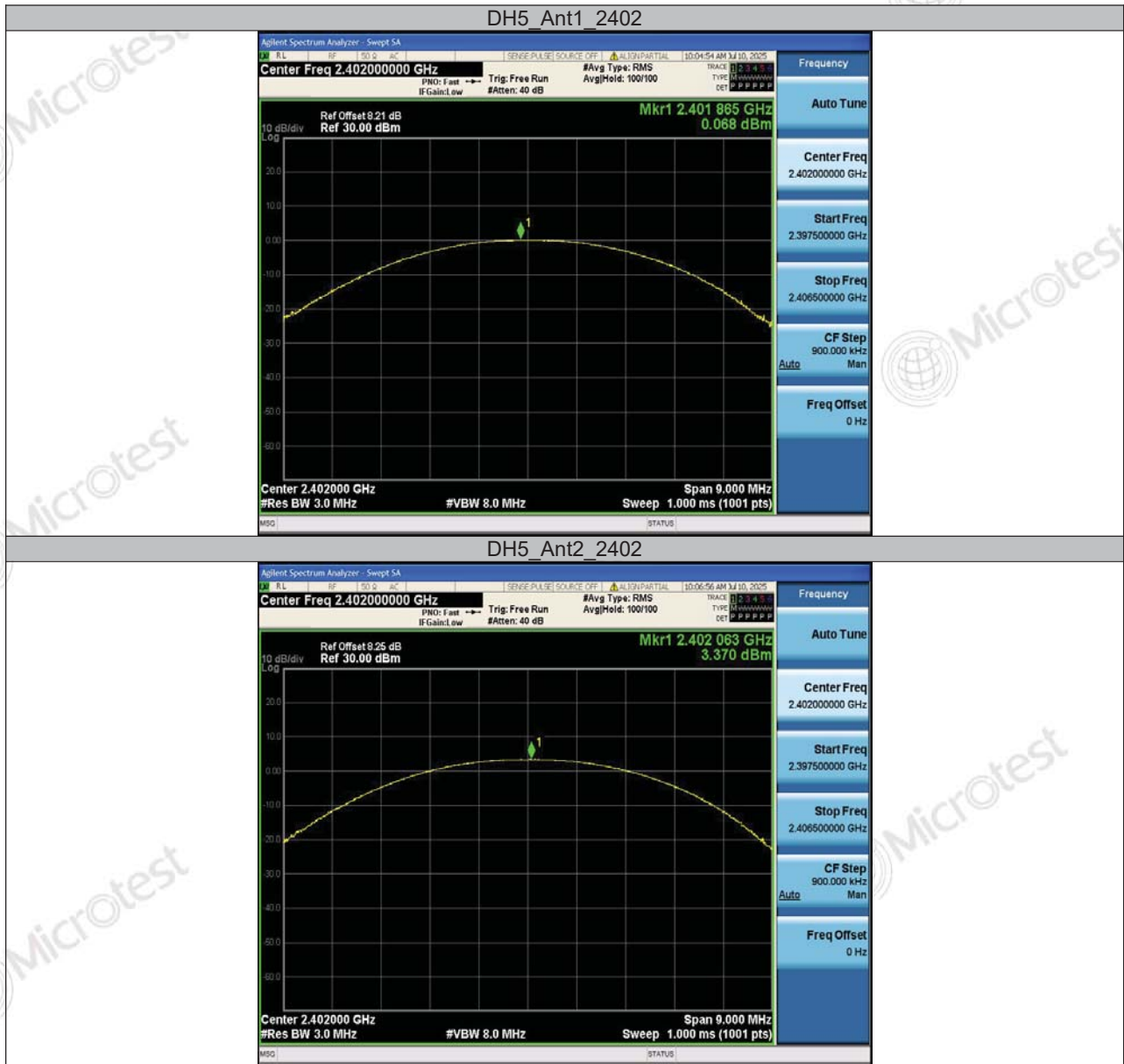

TEST REPORT

Report No.: MTI250319006-0104E1



TEST REPORT

Report No.: MTI250319006-0104E1

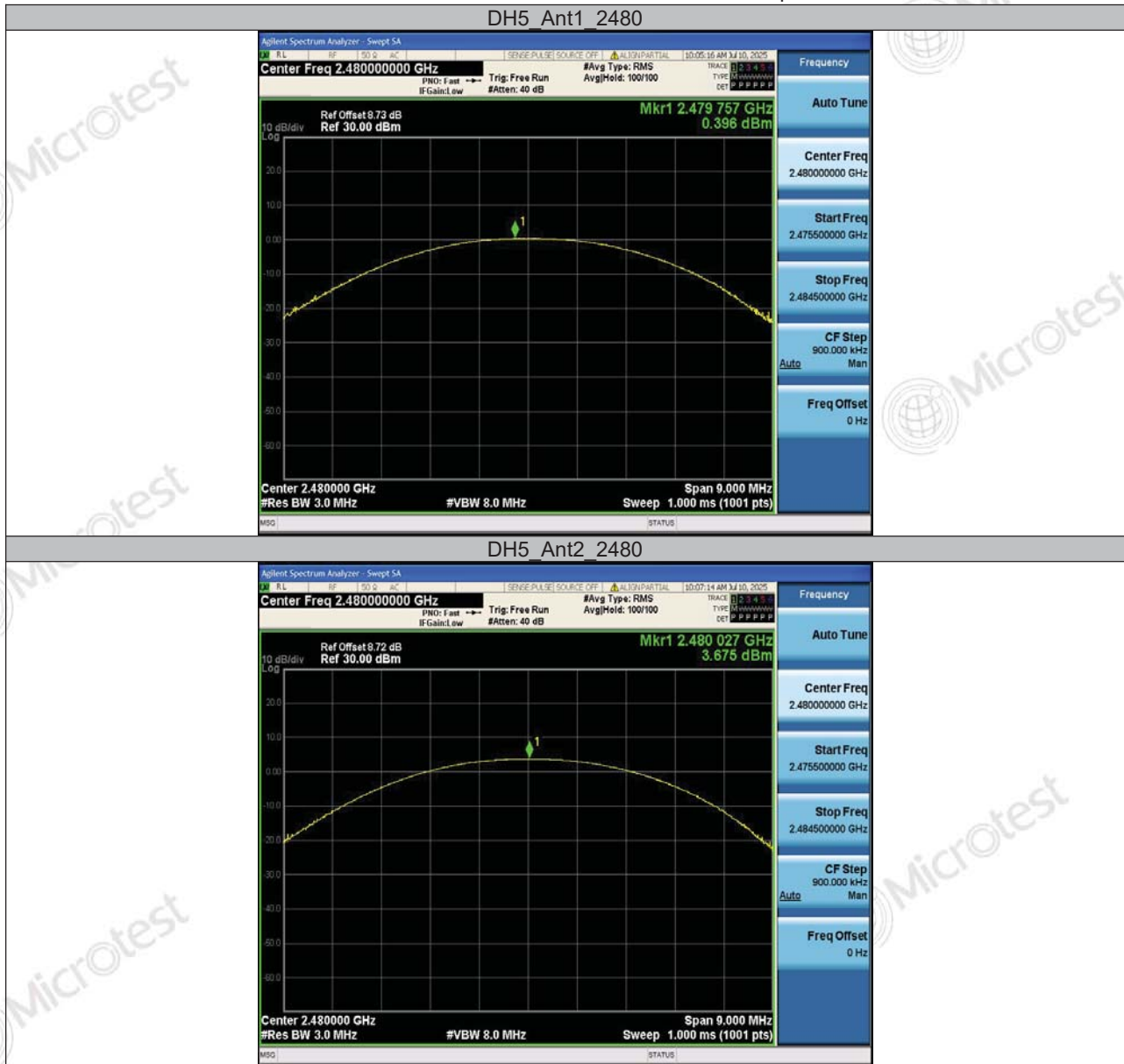

TEST REPORT

Report No.: MTI250319006-0104E1

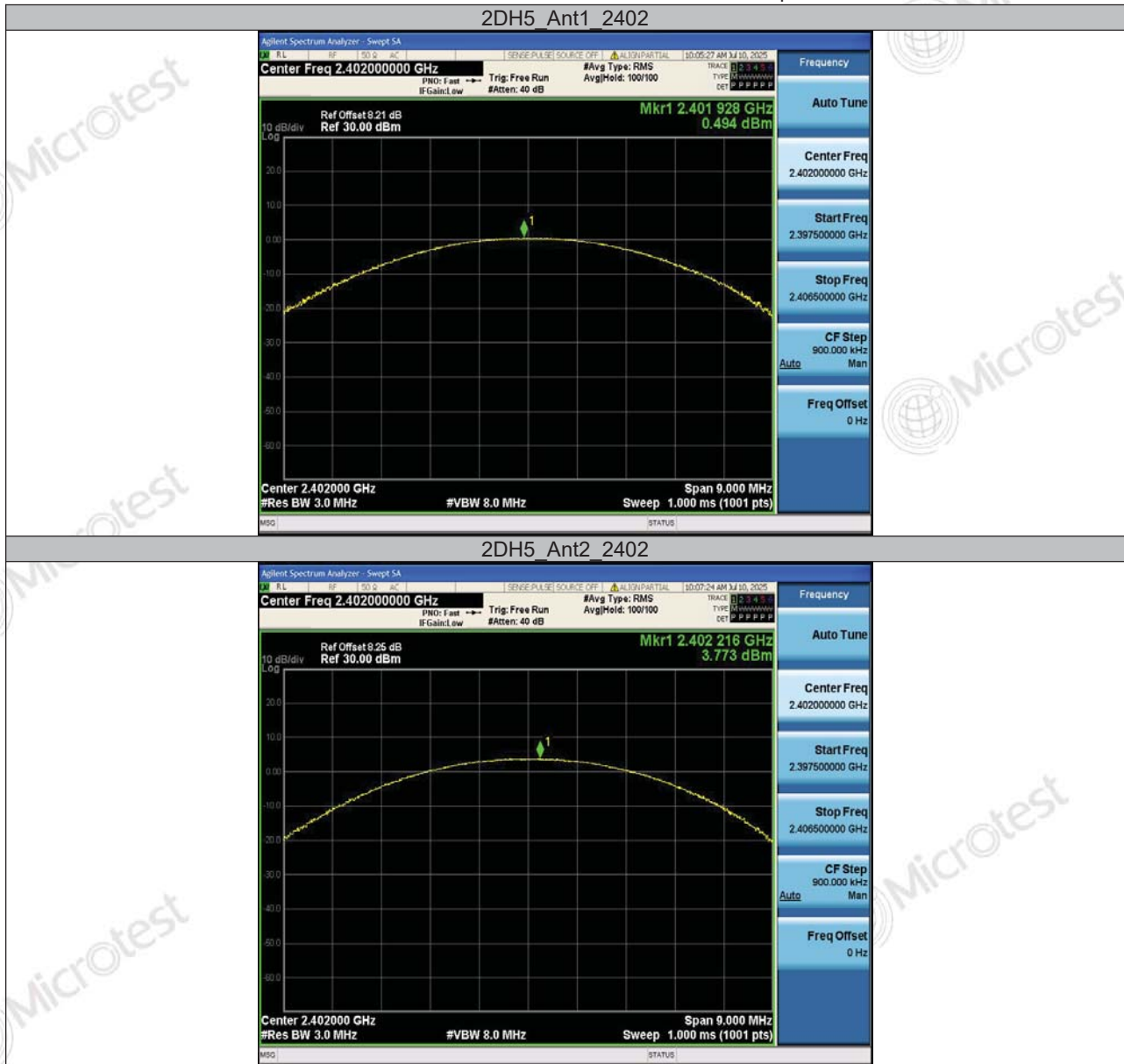

TEST REPORT

Report No.: MTI250319006-0104E1

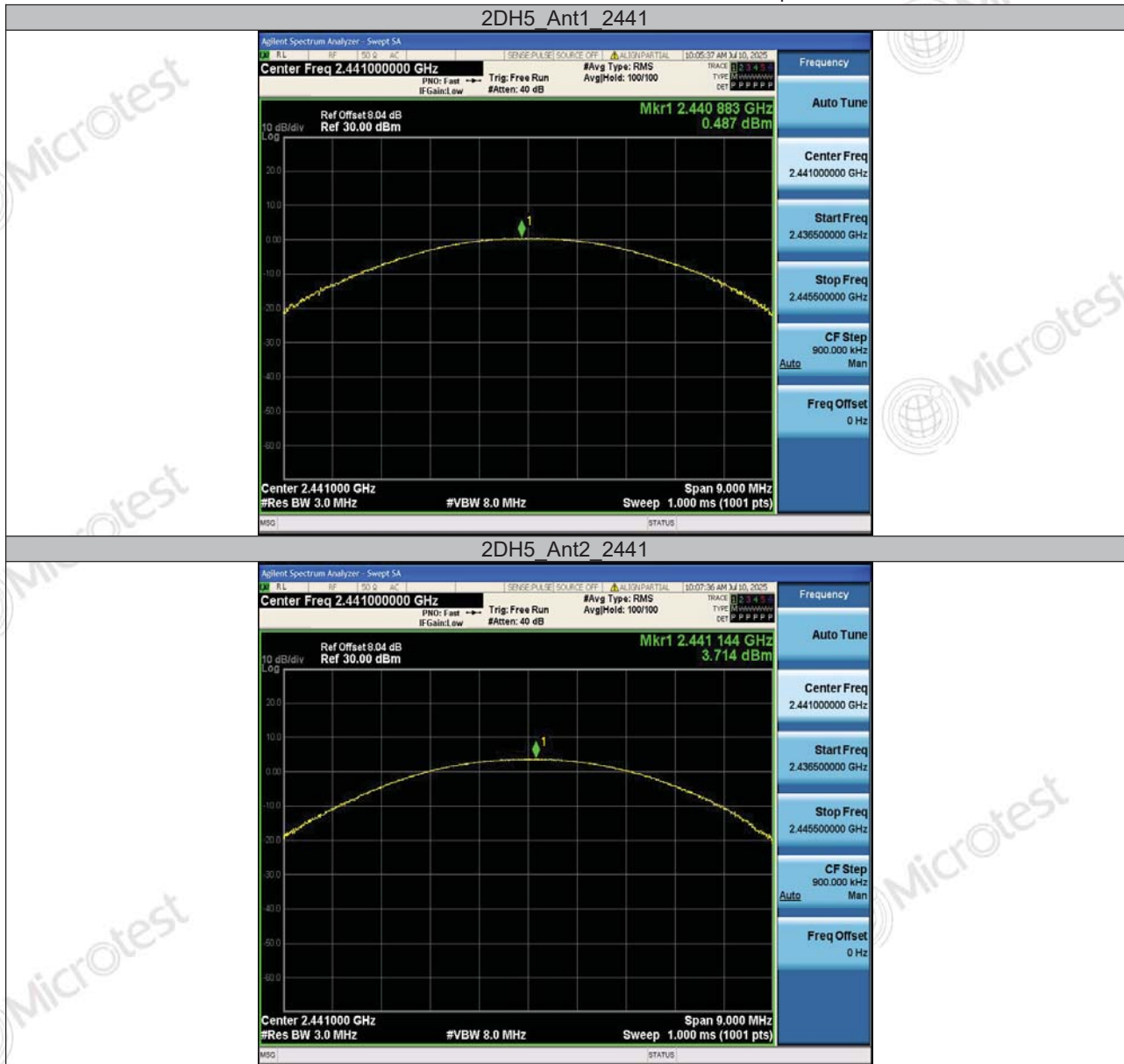

TEST REPORT

Report No.: MTI250319006-0104E1

