

TEST REPORT FOR WCDMA TESTING

Report No.: SRTC2019-9004(F)-19011703(B)

Product Name: Mobile Phone

Product Model: HLTE215E

Applicant: Hisense International Co., Ltd.

Manufacturer: Hisense Communications Co., Ltd.

Specification: FCC Part 24E, Part 22H, Part 2, Part 27 (2019)

FCC ID: 2ADOBHLTE215E

The State Radio_monitoring_center Testing Center (SRTC)

15th Building, No.30 Shixing Street, Shijingshan District,

Beijing, P.R.China

Tel: 86-10-57996183 Fax: 86-10-57996388

CONTENTS

1. GENERAL INFORMATION	2
1.1 NOTES OF THE TEST REPORT	2
1.2 INFORMATION ABOUT THE TESTING LABORATORY	2
1.3 APPLICANT’S DETAILS	2
1.4 MANUFACTURER’S DETAILS	2
1.5 TEST ENVIRONMENT	3
2 DESCRIPTION OF THE DEVICE UNDER TEST.....	4
2.1 FINAL EQUIPMENT BUILD STATUS.....	4
2.2 SUPPORT EQUIPMENT.....	5
2.3 CONDUCTED MEASUREMENT PATH LOSS.....	5
2.4 SUMMARY TABLE.....	5
3 REFERENCE SPECIFICATION.....	6
4 KEY TO NOTES AND RESULT CODES	7
5 RESULT SUMMARY	8
6 TEST RESULT.....	9
6.1 RF POWER OUTPUT-FCC PART 22.913(A)/PART24.232(B)	9
6.2 EFFECTIVE ISOTROPIC RADIATED POWER-FCC 22.913(A)/24.232(B) /27.50(D)(4)	10
6.3 OCCUPIED BANDWIDTH-FCC 2.1049/ 27.53(H)(1).....	12
6.4 EMISSION BANDWIDTH-FCC 22.917(B)/24.238(B)	13
6.5 SPURIOUS EMISSIONS AT ANTENNA TERMINAL-FCC 2.1051/ 22.917(A)/24.238(A)/ 27.53(H).....	15
6.6 BAND EDGES COMPLIANCE-FCC 22.917(B)/24.238(B)/ 27.53(H)	17
6.7 FREQUENCY STABILITY-FCC 2.1055/22.355/24.235/27.54	19
6.8 RADIATED SPURIOUS EMISSIONS-FCC 2.1053/22.917(A)/24.238(A)/ 27.53(H), 27.53(G)	21
6.9 PEAK-AVERAGE RATIO -FCC 24.232(D)/ 27.50(D)(5).....	26
7 MEASUREMENT UNCERTAINTIES	27
8 TEST EQUIPMENTS	28
APPENDIX A – TEST DATA OF CONDUCTED EMISSION.....	29
APPENDIX B – TEST DATA OF RADIATED EMISSION.....	64

1. GENERAL INFORMATION

1.1 Notes of the test report

The test report may only be reproduced or published in full. Reproduction or publication of extracts from the report requires the prior written permission of The State Radio_monitoring_center Testing Center (SRTC).

The test results relate only to individual items of the samples which have been tested.

The certification and accreditation identifiers used in this report shall not be applicable to the tested or calibrated samples thereof. The manufacturer shall not mark the tested samples or items (or a separate part of the item) with the identifiers of certification and accreditation to mislead relevant parties about the tested samples or items.

1.2 Information about the testing laboratory

Company:	The State Radio_monitoring_center Testing Center (SRTC)
Address:	15th Building, No.30 Shixing Street, Shijingshan District, P.R.China
City:	Beijing
Country or Region:	P.R.China
Contacted person:	Liu Jia
Tel:	+86 10 57996183
Fax:	+86 10 57996388
Email:	liujiaf@srtc.org.cn

1.3 Applicant's details

Company:	Hisense International Co., Ltd.
Address:	Floor 22, Hisense Tower, 17 Donghai Xi Road, Qingdao, 266071, China
City:	Qingdao
Country or Region:	China
Contacted person:	Geng Ruifeng
Tel:	+86-532-80877742
Fax:	---
Email:	gengruifeng@hisense.com

1.4 Manufacturer's details

Company:	Hisense Communications Co., Ltd.
Address:	218 Qianwangang Road, Qingdao Economic & Technological Development Zone, Qingdao, China
City:	Qingdao
Country or Region:	China
Contacted person:	Zhang chuanzhu
Tel:	+86-532-55756010
Fax:	---
Email:	zhangchuanzhu@hisense.com

1.5 Test Environment

Date of Receipt of test sample at SRTC:	2019-01-17
Testing Start Date:	2019-01-17
Testing End Date:	2019-03-06

Environmental Data:	Temperature (°C)	Humidity (%)
Ambient	25	30
Maximum Extreme	35	---
Minimum Extreme	0	---

Normal Supply Voltage (V d.c.):	3.85
Maximum Extreme Supply Voltage (V d.c.):	4.40
Minimum Extreme Supply Voltage (V d.c.):	3.50

2 DESCRIPTION OF THE DEVICE UNDER TEST

2.1 Final Equipment Build Status

Frequency Range	WCDMA Band II: Tx:1852.4~1907.6MHz Rx:1932.4~1987.6MHz WCDMA Band IV: Tx:1712.4~1752.6MHz Rx:2112.4~2152.6MHz WCDMA Band V: Tx:826.4~846.6MHz Rx:871.4~891.6MHz
Mode	HSDPA/HSUPA/HSPA+
Emission Designator	4M50F9W
Duplex Mode	FDD
Duplex Spacing	WCDMA Band II:80MHz WCDMA Band IV:400MHz WCDMA Band V:45MHz
Antenna Type	PIFA Antenna
Antenna Information	Main Ant(Down-Ant) support WCDMA B2/4/5 DIV Ant(Up-Ant) support WCDMA B4/5
Power Supply	Battery/Charger
HW Version	V1.00
SW Version	L1592.6.01.05.MX05
IMEI	002101541913327

2.2 Support Equipment

The following support equipment was used to exercise the DUT during testing:

Equipment	Battery
Manufacturer	Huizhou Highpower Technology Co., Ltd.
Model Number	LPN385300A
Serial Number	---

Equipment	Charger
Manufacturer	JIANGSU CHENYANG ELECTRON CO.,LTD
Model Number	CC10-050200U
Serial Number	---

Equipment	Headset
Manufacturer	NEW LEADER INDUSTRY CO.,LTD
Model Number	NLD-EM116T-046S
Serial Number	---

Equipment	USB Cable
Manufacturer	SHENZHEN FKY-QY HARDWARE ELECTRONIC CO.,LTD
Model Number	FKYM1-2428L10WHR-C1
Serial Number	---

2.3 Conducted measurement Path Loss

WCDMA B2 Offset 6.8dB = Power Divider 6dB+ Temporary antenna connector loss 0.2dB+ Cable loss 0.6dB

WCDMA B4 Offset 6.8dB = Power Divider 6dB+ Temporary antenna connector loss 0.2dB+ Cable loss 0.6dB

WCDMA B5 Offset 6.5dB = Power Divider 6dB+ Temporary antenna connector loss 0.2dB+ Cable loss 0.3dB

2.4 Summary table.

FCC Rule Part	Frequency Range(MHz)	Conducted Power (dBm)	ERP/EIRP (W)	Frequency Tolerance (ppm)	Emission Designator
24E	1852.4-1907.6	20.74	0.030	0.017	4M15F9W
22H	826.4-846.6	23.45	0.034	0.020	4M16F9W
27	1712.4-1752.6	22.42	0.049	0.019	4M15F9W

3 REFERENCE SPECIFICATION

Specification	Version	Title
2.1046	2019	Measurements required: RF power output.
2.1049	2019	Measurements required: Occupied bandwidth.
2.1051	2019	Measurements required: Spurious emissions at antenna terminals.
2.1053	2019	Measurements required: Field strength of spurious radiation.
2.1055	2019	Measurements required: Frequency stability.
22.355	2019	Frequency tolerance.
22.913	2019	Effective radiated power limits.
22.917	2019	Emission limitations for cellular equipment.
24.232	2019	Power and antenna height limits.
24.235/27.54	2019	Frequency stability.
24.238	2019	Emission limitations for Broadband PCS equipment.
27.50	2019	Power limits and duty cycle.
27.53	2019	Emission limits.
ANSI C63.26	2015	American National Standard for Compliance Testing of Transmitters Used in Licensed Radio Services
KDB 971168 D01	April 9, 2018	MEASUREMENT GUIDANCE FOR CERTIFICATION OF LICENSED DIGITAL TRANSMITTERS



4 KEY TO NOTES AND RESULT CODES

The following are the definition of the test result.

Code	Meaning
PASS	Test result shows that the requirements of the relevant specification have been met.
FAIL	Test result shows that the requirements of the relevant specification have not been met.
N/T	Test case is not tested.
NTC	Nominal voltage, Normal Temperature
HV	High voltage, Normal Temperature
LV	Low voltage, Normal Temperature
HTHV	high voltage, High Temperature
LTHV	High voltage, Low Temperature
HTLV	Low voltage, High Temperature
LTLV	Low voltage, Low Temperature

5 RESULT SUMMARY

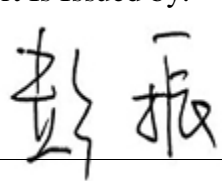
No.	Test case	FCC reference	Verdict
1	RF Power Output	22.913(a)/24.232(b)	Pass
2	Effective Radiated Power and Effective Isotropic Radiated Power	22.913(a)/24.232(b) /27.50(d)(4)	Pass
3	Occupied Bandwidth	2.1049/27.53(h)(1)	Pass
4	Emission Bandwidth	22.917(b)/24.238(b)	Pass
5	Spurious Emissions at antenna terminal	2.1051/22.917(a)/24.238(a)/ 27.53(h)	Pass
6	Band Edges Compliance	22.917(b)/24.238(b)/ 27.53(h)	Pass
7	Frequency Stability	2.1055/22.355/24.235/27.54	Pass
8	Radiated Spurious Emissions	2.1053/22.917(a)/24.238(a)/ 27.53(h), 27.53(g)	Pass
9	Peak-Average Ratio	24.232(d)/ 27.50(d)(5)	Pass

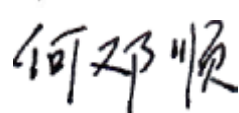
This Test Report Is Issued by: Mr. Peng Zhen 	Checked by: Mr. Li Bin 
Tested by: Mr. He Dengshun 	Issued date: 20190307

6 TEST RESULT

6.1 RF Power Output-FCC Part 22.913(a)/Part24.232(b)

Ambient condition:

Temperature	Relative humidity	Pressure
25°C	30%	101.9kPa

Test Setup:

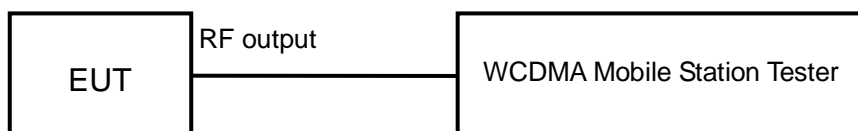

WCDMA band II

Test procedure:

After a radio link has been established between EUT and Tester, the output power of the cell signal of the testing equipment will be decreased until the output power of the EUT reach a maximum value. Then the test data can be read at the tester screen. The loss between RF output port of the EUT and the input port of the tester will be taken into consideration. The measurement will be conducted at three channels No9262, No9400 and No9538 (Bottom, middle and top channels of WCDMA band II)

Limits	≤24dBm
--------	--------

WCDMA band V

Test procedure:

After a radio link has been established between EUT and Tester, the output power of the cell signal of the testing equipment will be decreased until the output power of the EUT reach a maximum value. Then the test data can be read at the tester screen. The loss between RF output port of the EUT and the input port of the tester will be taken into consideration. The measurement will be conducted at three channels No4132, No4183 and No4233 (Bottom, middle and top channels of WCDMA band V)

Limits	≤24dBm
--------	--------

WCDMA band IV

Test procedure:

After a radio link has been established between EUT and Tester, the output power of the cell signal of the testing equipment will be decreased until the output power of the EUT reach a maximum value. Then the test data can be read at the tester screen. The loss between RF output port of the EUT and the input port of the tester will be taken into consideration. The measurement will be conducted at three channels No1312, No1412 and No1513 (Bottom, middle and top channels of WCDMA band IV)

Limits	≤24dBm
--------	--------

Test result:

The test results are shown in Appendix A.

6.2 Effective Isotropic Radiated Power-FCC 22.913(a)/24.232(b) /27.50(d)(4)

Ambient condition:

Temperature	Relative humidity	Pressure
25°C	30%	101.9kPa

Test Setup:

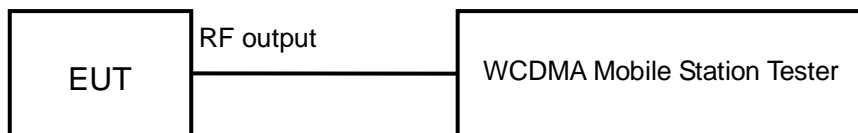

WCDMA band II

Test procedure:

After a radio link has been established between EUT and Tester, the output power of the cell signal of the testing equipment will be decreased until the output power of the EUT reach a maximum value. Then the test data can be read at the tester screen. The loss between RF output port of the EUT and the input port of the tester will be taken into consideration.

$$\text{Power (EIRP)} = P_{\text{mea}} + G_a$$

The measurement will be done at three channels No9262, No9400 and No9538 (Bottom, middle and top channels of WCDMA band II).

Limits	≤33.0dBm
--------	----------

WCDMA band V

Test procedure:

After a radio link has been established between EUT and Tester, the output power of the cell signal of the testing equipment will be decreased until the output power of the EUT reach a maximum value. Then the test data can be read at the tester screen. The loss between RF output port of the EUT and the input port of the tester will be taken into consideration.

$$\text{Power (EIRP)} = P_{\text{mea}} + G_a$$

This value is EIRP since the measurement is calibrated using an antenna of known gain (2.15dB) and known input power. ERP can be calculated from EIRP by subtracting the gain of the dipole, $\text{ERP} = \text{EIRP} - 2.15 \text{ (dB)}$.

The measurement will be done at three channels No4132, No4183 and No4233 (Bottom, middle and top channels of WCDMA band V)

Limits	$\leq 38.5\text{dBm}$
--------	-----------------------

WCDMA band IV

Test procedure:

After a radio link has been established between EUT and Tester, the output power of the cell signal of the testing equipment will be decreased until the output power of the EUT reach a maximum value. Then the test data can be read at the tester screen. The loss between RF output port of the EUT and the input port of the tester will be taken into consideration.

$$\text{Power (EIRP)} = P_{\text{mea}} + G_a$$

The measurement will be done at three channels No1312, No1412 and No1513 (Bottom, middle and top channels of WCDMA band IV).

Limits	$\leq 30.0\text{dBm}$
--------	-----------------------

Test result:

The test results are shown in Appendix A.

6.3 Occupied Bandwidth-FCC 2.1049/ 27.53(h)(1)

Ambient condition:

Temperature	Relative humidity	Pressure
25°C	30%	101.9kPa

Test Setup:

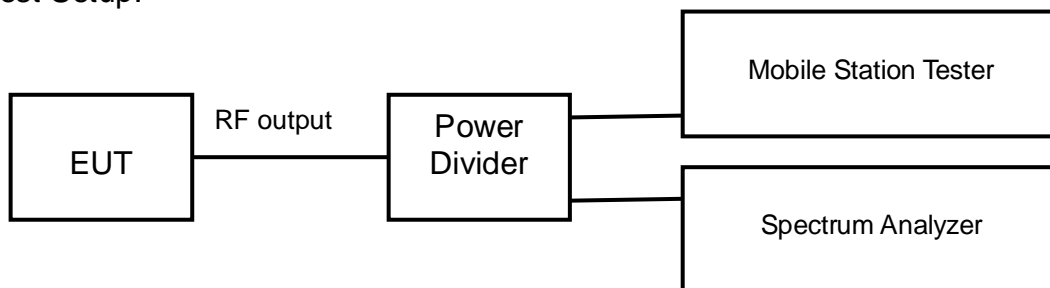

WCDMA band II

Test procedure:

After a radio link has been established between EUT and Tester, the output power of the cell signal of the testing equipment will be decreased until the output power of the EUT reach a maximum value. The occupied bandwidth is measured using spectrum analyzer. RBW is set to 51kHz on spectrum analyzer. The bandwidth of 99% power can be read on spectrum analyzer.

The measurement will be conducted at three channels No9262, No9400 and No9538 (Bottom, middle and top channels of WCDMA band II)

Limits: No specific occupied bandwidth requirements in part 2.1049

WCDMA band V

Test procedure:

After a radio link has been established between EUT and Tester, the output power of the cell signal of the testing equipment will be decreased until the output power of the EUT reach a maximum value. The occupied bandwidth is measured using spectrum analyzer. RBW is set to 30kHz on spectrum analyzer. The bandwidth of 99% power can be read on spectrum analyzer.

The measurement will be conducted at three channels No4132, No4183 and No4233 (Bottom, middle and top channels of WCDMA band V)

Limits: No specific occupied bandwidth requirements in part 2.1049

WCDMA band IV

Test procedure:

After a radio link has been established between EUT and Tester, the output power of the cell signal of the testing equipment will be decreased until the output power of the EUT reach a maximum value. The occupied bandwidth is measured using spectrum analyzer. RBW is set to 51kHz on spectrum analyzer. The bandwidth of 99% power can be read on spectrum analyzer.

The measurement will be conducted at three channels No1312, No1412 and No1513 (Bottom, middle and top channels of WCDMA band IV)

Limits: No specific occupied bandwidth requirements in part 2.1049

Test result:

The test results are shown in Appendix A.

6.4 Emission Bandwidth-FCC 22.917(b)/24.238(b)

Ambient condition:

Temperature	Relative humidity	Pressure
25°C	30%	101.9kPa

Test Setup:

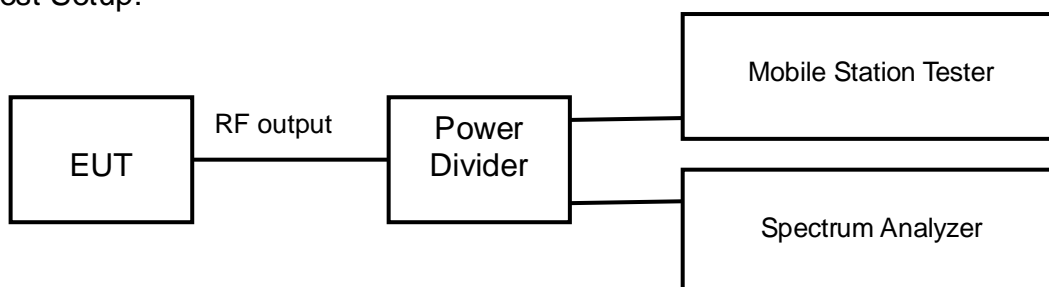

WCDMA band II

Test procedure:

After a radio link has been established between EUT and Tester, the output power of the cell signal of the testing equipment will be decreased until the output power of the EUT reach a maximum value. The emission bandwidth is measured using spectrum analyzer. RBW is set to 30kHz on spectrum analyzer. The bandwidth of -26dBc power can be read on spectrum analyzer.

The measurement will be conducted at three channels No9262, No9400 and No9538 (Bottom, middle and top channels of WCDMA band II)

Limits: No specific emission bandwidth requirements in part 24.238(b)

WCDMA band V

Test procedure:

After a radio link has been established between EUT and Tester, the output power of the cell signal of the testing equipment will be decreased until the output power of the EUT reach a maximum value. The emission bandwidth is measured using spectrum analyzer. RBW is set to 30kHz on spectrum analyzer. The bandwidth of -26dBc power can be read on spectrum analyzer.

The measurement will be conducted at three channels No9262, No9400 and No9538 (Bottom, middle and top channels of WCDMA band V)

Limits: No specific emission bandwidth requirements in part 22.917(b)

WCDMA band IV

Test procedure:

After a radio link has been established between EUT and Tester, the output power of the cell signal of the testing equipment will be decreased until the output power of the EUT reach a maximum value. The emission bandwidth is measured using spectrum analyzer. RBW is set to 30kHz on spectrum analyzer. The bandwidth of -26dBc power can be read on spectrum analyzer.

The measurement will be conducted at three channels No1312, No1412 and No1513 (Bottom, middle and top channels of WCDMA band IV)

Limits: No specific emission bandwidth requirements in part 24.238(b)

Test result:

The test results are shown in Appendix A.

6.5 Spurious Emissions at antenna terminal-FCC 2.1051/ 22.917(a)/24.238(a)/ 27.53(h)

Ambient condition:

Temperature	Relative humidity	Pressure
25°C	30%	101.9kPa

Test Setup:

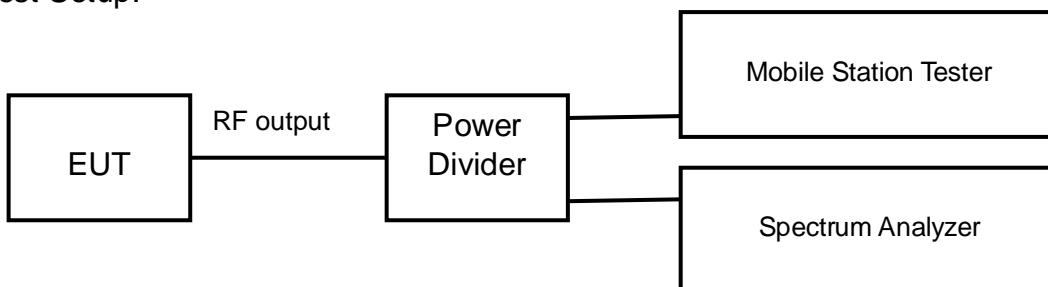

WCDMA band II

Test procedure:

After a radio link has been established between EUT and Tester, the output power of the cell signal of the testing equipment will be decreased until the output power of the EUT reach a maximum value. The measurement is carried out using a spectrum analyzer. The spectrum analyzer scans from 30MHz to 20GHz (higher than the 10th harmonic of the carrier). The peak detector is used and RBW is set to 1MHz on spectrum analyzer.

The measurement will be conducted at one channel No9400 (middle channel of WCDMA band II)

Limits	≤-13dBm
--------	---------

WCDMA band V

Test procedure:

After a radio link has been established between EUT and Tester, the output power of the cell signal of the testing equipment will be decreased until the output power of the EUT reach a maximum value. The measurement is carried out using a spectrum analyzer. The spectrum analyzer scans from 30MHz to 9GHz (higher than the 10th harmonic of the carrier). The peak detector is used and RBW is set to 1MHz on spectrum analyzer.

The measurement will be conducted at one channel No4183 (middle channel of WCDMA band V)

Limits	≤-13dBm
--------	---------

WCDMA band IV

Test procedure:

After a radio link has been established between EUT and Tester, the output power of the cell signal of the testing equipment will be decreased until the output power of the EUT reach a maximum value. The measurement is carried out using a spectrum analyzer. The spectrum analyzer scans from 30MHz to 20GHz (higher than the 10th harmonic of the carrier). The peak detector is used and RBW is set to 1MHz on spectrum analyzer.

The measurement will be conducted at one channel No1412 (middle channel of WCDMA band IV)

Limits	$\leq -13\text{dBm}$
--------	----------------------

Test result:

The test results are shown in Appendix A.

6.6 Band Edges Compliance-FCC 22.917(b)/24.238(b)/ 27.53(h)

Ambient condition:

Temperature	Relative humidity	Pressure
25°C	30%	101.9kPa

Test Setup:

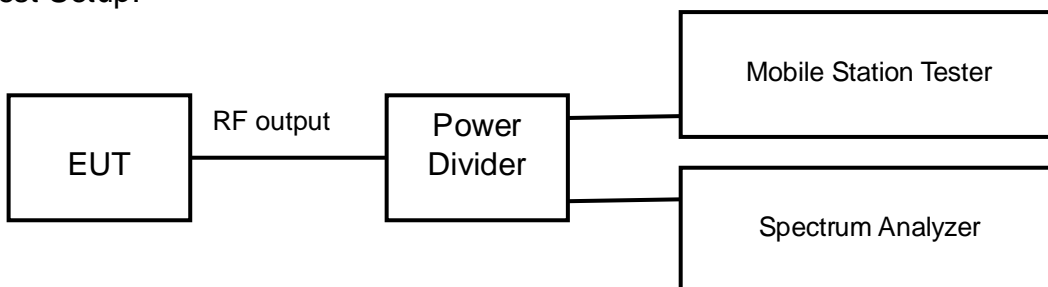

WCDMA band II

Test procedure:

After a radio link has been established between EUT and Tester, the output power of the cell signal of the testing equipment will be decreased until the output power of the EUT reach a maximum value. The measurement is carried out using a spectrum analyzer. The peak detector is used and RBW is set to at least 1% of the emission bandwidth on spectrum analyzer.

The measurement will be conducted at two channels No9262 and No9538 (Bottom and top channels of WCDMA band II)

Limits	$\leq -13\text{dBm}$
--------	----------------------

WCDMA band V

Test procedure:

After a radio link has been established between EUT and Tester, the output power of the cell signal of the testing equipment will be decreased until the output power of the EUT reach a maximum value. The measurement is carried out using a spectrum analyzer. The peak detector is used and RBW is set to at least 1% of the emission bandwidth on spectrum analyzer.

The measurement will be conducted at two channels No4132 and No4233 (Bottom and top channels of WCDMA band V)

Limits	$\leq -13\text{dBm}$
--------	----------------------

WCDMA band IV

Test procedure:

After a radio link has been established between EUT and Tester, the output power of the cell signal of the testing equipment will be decreased until the output power of the EUT reach a maximum value. The measurement is carried out using a spectrum analyzer. The peak detector is used and RBW is set to at least 1% of the emission bandwidth on spectrum analyzer.

The measurement will be conducted at two channels No1312 and No1513 (Bottom and top channels of WCDMA band IV)

Limits	$\leq -13\text{dBm}$
--------	----------------------

Test result:

The test results are shown in Appendix A.

6.7 Frequency Stability-FCC 2.1055/22.355/24.235/27.54

Ambient condition:

Temperature	Relative humidity	Pressure
25°C	30%	101.9kPa

Test setup:

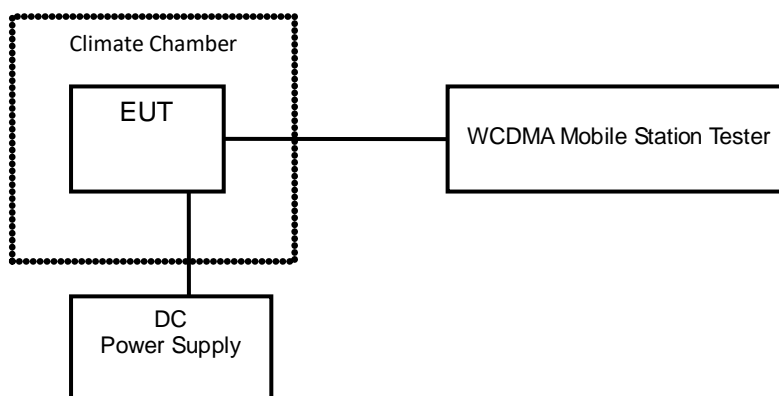

WCDMA band II

Test Procedure:

A radio link shall be established between EUT and Tester. The tester will sample the transmitter RF output signal and measure its frequency. The temperature inside the climate chamber is varied from -30 to +50°C in 10°C step size, and also the DC power supply voltage to the EUT is varied from LV to HV. The measurement will be conducted at three channels No9262, No9400 and No9538 (Bottom, middle and top channels of WCDMA band II).

Limits: No specific frequency stability requirements in part 2.1055 and part 24.235.

WCDMA band V

Test Procedure:

A radio link shall be established between EUT and Tester. The tester will sample the transmitter RF output signal and measure its frequency. The temperature inside the climate chamber is varied from -30 to +50°C in 10°C step size, and also the DC power supply voltage to the EUT is varied from LV to HV. The measurement will be conducted at three channels No4132, No4183 and No4233 (Bottom, middle and top channels of WCDMA band V).

Limits: No specific frequency stability requirements in part 2.1055 and part 22.355.

WCDMA band IV

Test Procedure:

A radio link shall be established between EUT and Tester. The tester will sample the transmitter RF output signal and measure its frequency. The temperature inside the climate chamber is varied from -30 to +50°C in 10°C step size, and also the DC power supply voltage to the EUT is varied from LV to HV. The measurement will be conducted at three channels No1312, No1412 and No1513 (Bottom, middle and top channels of WCDMA band IV).

Limits: No specific frequency stability requirements in part 2.1055 and part 24.235.

Test result:

The test results are shown in Appendix A.

6.8 Radiated Spurious Emissions-FCC 2.1053/22.917(a)/24.238(a)/ 27.53(h), 27.53(g)

Ambient condition:

Temperature	Relative humidity	Pressure
25°C	30%	101.9kPa

Test Setup:

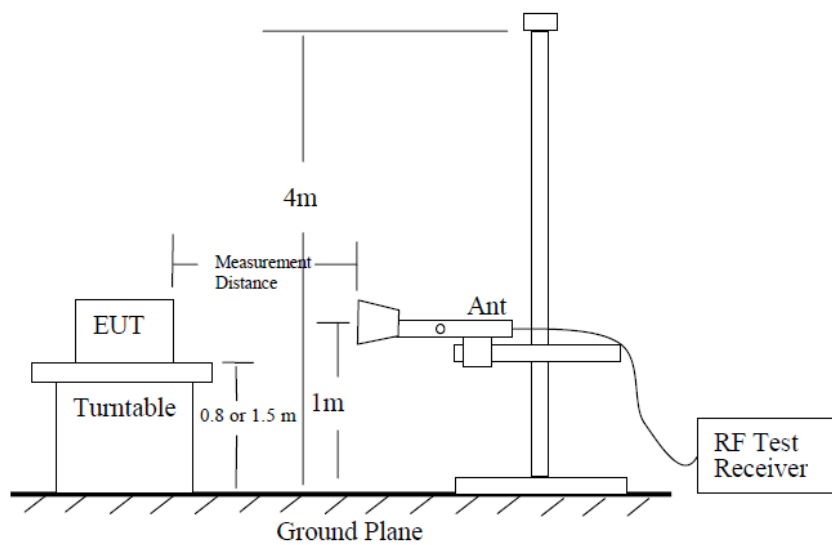

Step 1

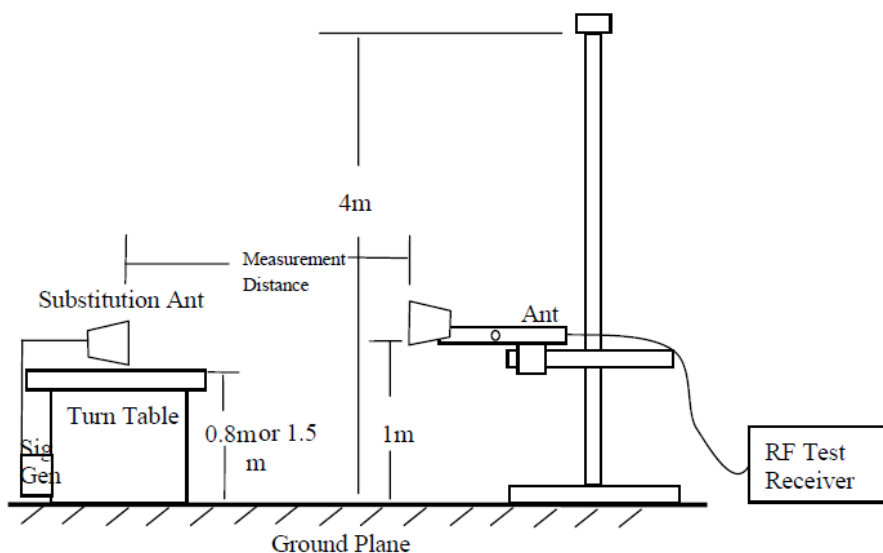

Step 2

WCDMA band II

Test procedure:

The measurements procedures in TIA-603C-2004 are used.

The spectrum was scanned from 30MHz to the 10th harmonic of the highest frequency generated within the equipment.

Step 1:

The measurement is carried out in the fully anechoic chamber. EUT was placed on a 2.4 meter high non-conductive table at a 3 meter test distance from the test receive antenna. A receiving antenna was placed on the antenna mast 3 meters from the EUT. The height of receiving antenna is 2.4m and varies in certain range to find the maximum power value. A radio link shall be established between EUT and Tester. The output power of the cell signal of the tester will be decreased until the output power of the EUT reach a maximum value. The measurement is carried out using a spectrum analyzer or receiver. The spectrum analyzer scans from 30MHz to 20GHz (higher than the 10th harmonic of the carrier). The peak detector is used and RBW is set to 1MHz on spectrum analyzer. Then the antenna height and turn table rotation is adjusted till the maximum power value is founded on spectrum analyzer or receiver. A notch filter is necessary in the band near to the carrier frequency. A high pass filter is needed to avoid the distortion of the testing equipment in the band above the carrier frequency.

Step 2:

A log-periodic antenna or double-ridged waveguide horn antenna shall be substituted in place of the EUT. The log-periodic antenna will be driven by a signal generator and the level will be adjusted till the same power value on the spectrum analyzer or receiver. The level of the spurious emissions can be calculated through the level of the signal generator, cable loss, the gain of the substitution antenna and the reading of the spectrum analyzer or receiver.

A power (P_{mea}) is applied to the input of the substitution antenna, and adjusts the level of the signal generator output until the value of the receiver reach the previously recorded (P_r). The power of signal source (P_{mea}) is recorded. The test should be performed by rotating the test item and adjusting the receiving antenna polarization.

A "reference path loss" should be calculated after test. The attenuation of "reference path loss" is the cable loss between the Signal Source with the Substitution Antenna (P_{ca}) and the Substitution Antenna Gain (G_a).

Calculation procedure:

The data of cable loss and antenna gain has been calibrated in full testing frequency range before the testing.

The power of the Radiated Spurious Emissions is calculated by adding the cable loss and antenna gain. The basic equation with a sample calculation is as followed:

$$\text{Power(EIRP)} = P_{mea} + P_{ca} + G_a$$

This value is EIRP since the measurement is calibrated using an antenna of known gain (2.15dB) and known input power. ERP can be calculated from EIRP by subtracting the gain of the dipole, $\text{ERP} = \text{EIRP} - 2.15 \text{ (dB)}$.

Assumed the power of signal source record is -20dBm. A cable loss of -30dB, and an

antenna gain of 11dB are added.

$$P=P_{\text{mea}}+P_{\text{ca}}+G_{\text{a}}=(-20\text{dBm})+(-30\text{dB})+(11\text{dB})=-39\text{dBm}$$

The measurement will be done at carrier frequencies that pertain to bottom (Channel 9262), middle (Channel 9400) and top (Channel 9538) channels of WCDMA band II.

WCDMA band V

Test procedure:

The measurements procedures in TIA-603C-2004 are used.

The spectrum was scanned from 30MHz to the 10th harmonic of the highest frequency generated within the equipment.

Step 1:

The measurement is carried out in the fully anechoic chamber. EUT was placed on a 2.4 meter high non-conductive table at a 3 meter test distance from the test receive antenna. A receiving antenna was placed on the antenna mast 3 meters from the EUT. The height of receiving antenna is 2.4m and varies in certain range to find the maximum power value. A radio link shall be established between EUT and Tester. The output power of the cell signal of the tester will be decreased until the output power of the EUT reach a maximum value. The measurement is carried out using a spectrum analyzer or receiver. The spectrum analyzer scans from 30MHz to 20GHz (higher than the 10th harmonic of the carrier). The peak detector is used and RBW is set to 1MHz on spectrum analyzer. Then the antenna height and turn table rotation is adjusted till the maximum power value is founded on spectrum analyzer or receiver. A notch filter is necessary in the band near to the carrier frequency. A high pass filter is needed to avoid the distortion of the testing equipment in the band above the carrier frequency.

Step 2:

A log-periodic antenna or double-ridged waveguide horn antenna shall be substituted in place of the EUT. The log-periodic antenna will be driven by a signal generator and the level will be adjusted till the same power value on the spectrum analyzer or receiver. The level of the spurious emissions can be calculated through the level of the signal generator, cable loss, the gain of the substitution antenna and the reading of the spectrum analyzer or receiver.

A power (P_{mea}) is applied to the input of the substitution antenna, and adjusts the level of the signal generator output until the value of the receiver reach the previously recorded (P_{r}). The power of signal source (P_{mea}) is recorded. The test should be performed by rotating the test item and adjusting the receiving antenna polarization.

A "reference path loss" should be calculated after test. The attenuation of "reference path loss" is the cable loss between the Signal Source with the Substitution Antenna (P_{ca}) and the Substitution Antenna Gain (G_{a}).

Calculation procedure:

The data of cable loss and antenna gain has been calibrated in full testing frequency range before the testing.

The power of the Radiated Spurious Emissions is calculated by adding the cable loss and antenna gain. The basic equation with a sample calculation is as followed:

$$\text{Power(EIRP)} = P_{\text{mea}} + P_{\text{ca}} + G_a$$

This value is EIRP since the measurement is calibrated using an antenna of known gain (2.15dB) and known input power. ERP can be calculated from EIRP by subtracting the gain of the dipole, $\text{ERP} = \text{EIRP} - 2.15 \text{ (dB)}$.

Assumed the power of signal source record is -20dBm. A cable loss of -30dB, and an antenna gain of 11dB are added.

$$P = P_{\text{mea}} + P_{\text{ca}} + G_a = (-20\text{dBm}) + (-30\text{dB}) + (11\text{dB}) = -39\text{dBm}$$

The measurement will be done at carrier frequencies that pertain to bottom (Channel 4132), middle (Channel 4183) and top (Channel 4233) channels of WCDMA band V.

WCDMA band IV

Test procedure:

The measurements procedures in TIA-603C-2004 are used.

The spectrum was scanned from 30MHz to the 10th harmonic of the highest frequency generated within the equipment.

Step 1:

The measurement is carried out in the fully anechoic chamber. EUT was placed on a 2.4 meter high non-conductive table at a 3 meter test distance from the test receive antenna. A receiving antenna was placed on the antenna mast 3 meters from the EUT. The height of receiving antenna is 2.4m and varies in certain range to find the maximum power value. A radio link shall be established between EUT and Tester. The output power of the cell signal of the tester will be decreased until the output power of the EUT reach a maximum value. The measurement is carried out using a spectrum analyzer or receiver. The spectrum analyzer scans from 30MHz to 20GHz (higher than the 10th harmonic of the carrier). The peak detector is used and RBW is set to 1MHz on spectrum analyzer. Then the antenna height and turn table rotation is adjusted till the maximum power value is founded on spectrum analyzer or receiver. A notch filter is necessary in the band near to the carrier frequency. A high pass filter is needed to avoid the distortion of the testing equipment in the band above the carrier frequency.

Step 2:

A log-periodic antenna or double-ridged waveguide horn antenna shall be substituted in place of the EUT. The log-periodic antenna will be driven by a signal generator and the level will be adjusted till the same power value on the spectrum analyzer or receiver. The level of the spurious emissions can be calculated through the level of the signal generator, cable loss, the gain of the substitution antenna and the reading of the spectrum analyzer or receiver.

A power (P_{mea}) is applied to the input of the substitution antenna, and adjusts the level of the signal generator output until the value of the receiver reach the previously recorded (P_r). The power of signal source (P_{mea}) is recorded. The test should be performed by rotating the test item and adjusting the receiving antenna polarization.

A "reference path loss" should be calculated after test. The attenuation of "reference path loss" is the cable loss between the Signal Source with the Substitution Antenna (P_{ca}) and

the Substitution Antenna Gain (Ga).

Calculation procedure:

The data of cable loss and antenna gain has been calibrated in full testing frequency range before the testing.

The power of the Radiated Spurious Emissions is calculated by adding the cable loss and antenna gain. The basic equation with a sample calculation is as followed:

$$\text{Power(EIRP)} = P_{\text{mea}} + P_{\text{ca}} + G_a$$

This value is EIRP since the measurement is calibrated using an antenna of known gain (2.15dB) and known input power. ERP can be calculated from EIRP by subtracting the gain of the dipole, $\text{ERP} = \text{EIRP} - 2.15 \text{ (dB)}$.

Assumed the power of signal source record is -20dBm. A cable loss of -30dB, and an antenna gain of 11dB are added.

$$P = P_{\text{mea}} + P_{\text{ca}} + G_a = (-20\text{dBm}) + (-30\text{dB}) + (11\text{dB}) = -39\text{dBm}$$

The measurement will be done at carrier frequencies that pertain to bottom (Channel 1312), middle (Channel 1412) and top (Channel 1513) channels of WCDMA band IV.

Test result:

The test results are shown in Appendix B.

6.9 Peak-Average Ratio -FCC 24.232(d)/ 27.50(d)(5)

Ambient condition:

Temperature	Relative humidity	Pressure
25°C	30%	101.9kPa

Test Setup:

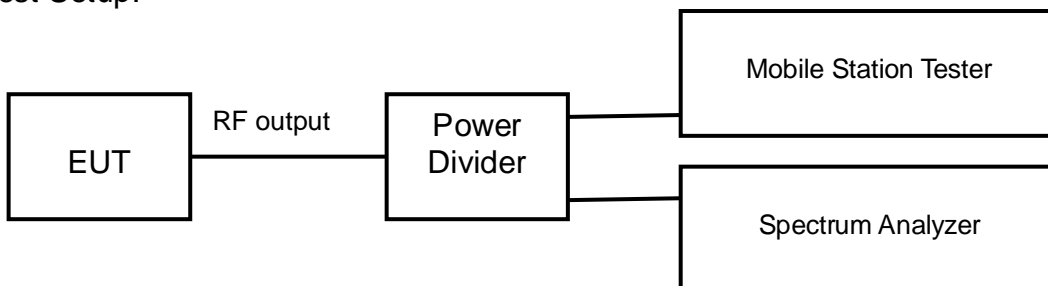

Test procedure:

After a radio link has been established between EUT and Tester, the output power of the cell signal of the testing equipment will be decreased until the output power of the EUT reach a maximum value. The Peak-Average Ratio is measured using spectrum analyzer. RBW is set to 30kHz on spectrum analyzer. The Peak-Average Ratio can be read on spectrum analyzer.

Limits: the peak-to-average ratio (PAR) of the transmission may not exceed 13 dB.

Test result:

The test results are shown in Appendix A

7 MEASUREMENT UNCERTAINTIES

Items	Uncertainty	
RF Power Output	U=0.6 dB	
Occupied Bandwidth	3kHz	
Spurious Emissions	9kHz~2GHz	U=1.2dB
	2G~3.6GHz	U=1.4dB
	3.6G~8GHz	U=2.2dB
	8G~12.75GHz	U=2.7dB
Band Edges Compliance	1.2dB	
Frequency Stability	U=48 Hz	

8 TEST EQUIPMENTS

No.	Name/Model	Manufacturer	S/N	Calibration Date	Calibration Due Date
1	E5515C(8960) Mobile Station Tester	Agilent	MY50266302	2018.08.20	2019.08.19
2	N9020A Spectrum Analyzer	Agilent	MY48010771	2018.08.20	2019.08.19
3	6007 Power Divider	Weinschel	6007-GJ-1	2018.08.20	2019.08.19
4	DC Power Supply E3645A	Agilent	MY40000741	2019.03.01	2020.02.28
5	Temperature chamber SH241	ESPEC	92013758	2018.08.20	2019.08.19
6	12.65m×8.03m×7.50m Fully-Anechoic Chamber	FRANKONIA	----	----	----
7	23.18m×16.88m×9.60m Semi-Anechoic Chamber	FRANKONIA	---	----	----
8	Turn table Diameter:1m	FRANKONIA	----	----	----
9	Turn table Diameter:5m	FRANKONIA	----	----	----
10	Antenna master FAC(MA4.0)	MATURO	----	----	----
11	Antenna master SAC(MA4.0)	MATURO	----	----	----
12	9.080m×5.255m×3.525m Shielding room	FRANKONIA	----	----	----
13	HF 907 Double-Ridged Waveguide Horn Antenna	R&S	100512	2018.08.20	2019.08.19
14	HF 907 Double-Ridged Waveguide Horn Antenna	R&S	100513	2018.08.20	2019.08.19
15	HL562 Ultra log antenna	R&S	100016	2018.08.20	2019.08.19
16	3160-09 Receive antenna	SCHWARZ-BECK	002058-002	2018.08.20	2019.08.19
17	ESI 40 EMI test receiver	R&S	100015	2018.08.20	2019.08.19
18	ESCS30 EMI test receiver	R&S	100029	2018.08.20	2019.08.19
19	HL562 Receive antenna	R&S	100167	2018.08.20	2019.08.19
20	ENV216 AMN	R&S	3560.6550.12	2018.08.20	2019.08.19

APPENDIX A – TEST DATA OF CONDUCTED EMISSION

Please refer to the attachment.

APPENDIX B – TEST DATA OF RADIATED EMISSION

Please refer to the attachment.

APPENDIX A – TEST DATA OF CONDUCTED EMISSION

RF Power Output-FCC Part 22.913(a)/Part24.232 (b)

Main ANT and DIV ANT are TX diversity switching.

WCDMA band II

Main Antenna Gain=-9.5dBi

Mode		Carrier frequency (MHz)	Channel No.	RF Power Output (dBm)	Main Ant EIRP (W)
Release 99	RMC, 12.2kbps	1852.4	9262	20.74	0.013
		1880.0	9400	20.66	0.013
		1907.6	9538	20.68	0.013
HSDPA	Subtest 1	1852.4	9262	20.74	0.013
		1880.0	9400	20.66	0.013
		1907.6	9538	20.65	0.013
	Subtest 2	1852.4	9262	20.64	0.013
		1880.0	9400	20.63	0.013
		1907.6	9538	20.65	0.013
	Subtest 3	1852.4	9262	20.66	0.013
		1880.0	9400	20.62	0.013
		1907.6	9538	20.63	0.013
	Subtest 4	1852.4	9262	20.64	0.013
		1880.0	9400	20.62	0.013
		1907.6	9538	20.65	0.013
HSUPA	Subtest 1	1852.4	9262	20.63	0.013
		1880.0	9400	20.62	0.013
		1907.6	9538	20.63	0.013
	Subtest 2	1852.4	9262	20.61	0.013
		1880.0	9400	20.64	0.013
		1907.6	9538	20.65	0.013
	Subtest 3	1852.4	9262	20.62	0.013
		1880.0	9400	20.61	0.013
		1907.6	9538	20.63	0.013
	Subtest 4	1852.4	9262	20.64	0.013
		1880.0	9400	20.64	0.013
		1907.6	9538	20.64	0.013
	Subtest 5	1852.4	9262	20.65	0.013
		1880.0	9400	20.63	0.013
		1907.6	9538	20.62	0.013
HSPA+	Subtest 1	1852.4	9262	20.62	0.013
		1880.0	9400	20.61	0.013
		1907.6	9538	20.64	0.013

WCDMA band V

Main Antenna Gain=-6.0dBi

DIV Antenna Gain=-7.0dBi

Mode		Carrier frequency (MHz)	Channel No.	RF Power Output (dBm)	Main Ant ERP (W)	DIV Ant ERP (W)
Release 99	RMC, 12.2kbps	826.4	4132	23.45	0.034	0.027
		836.6	4183	23.42	0.034	0.027
		846.6	4233	23.39	0.033	0.027
HSDPA	Subtest 1	826.4	4132	23.43	0.034	0.027
		836.6	4183	23.38	0.033	0.026
		846.6	4233	23.37	0.033	0.026
	Subtest 2	826.4	4132	23.36	0.033	0.026
		836.6	4183	23.36	0.033	0.026
		846.6	4233	23.33	0.033	0.026
	Subtest 3	826.4	4132	23.33	0.033	0.026
		836.6	4183	23.35	0.033	0.026
		846.6	4233	23.36	0.033	0.026
	Subtest 4	826.4	4132	23.32	0.033	0.026
		836.6	4183	23.34	0.033	0.026
		846.6	4233	23.36	0.033	0.026
HSUPA	Subtest 1	826.4	4132	23.35	0.033	0.026
		836.6	4183	23.33	0.033	0.026
		846.6	4233	23.35	0.033	0.026
	Subtest 2	826.4	4132	23.37	0.033	0.026
		836.6	4183	23.33	0.033	0.026
		846.6	4233	23.32	0.033	0.026
	Subtest 3	826.4	4132	23.35	0.033	0.026
		836.6	4183	23.34	0.033	0.026
		846.6	4233	23.33	0.033	0.026
	Subtest 4	826.4	4132	23.37	0.033	0.026
		836.6	4183	23.34	0.033	0.026
		846.6	4233	23.35	0.033	0.026
Subtest 5	826.4	4132	23.33	0.033	0.026	
	836.6	4183	23.32	0.033	0.026	
	846.6	4233	23.36	0.033	0.026	
HSPA+	Subtest 1	826.4	4132	23.32	0.033	0.026
		836.6	4183	23.33	0.033	0.026
		846.6	4233	23.34	0.033	0.026

WCDMA band IV

Main Antenna Gain=-9.5dBi

DIV Antenna Gain=-5.5dBi

Mode		Carrier frequency (MHz)	Channel No.	RF Power Output (dBm)	Main Ant EIRP (W)	DIV Ant EIRP (W)
Release 99	RMC, 12.2kbps	1712.4	1312	22.42	0.020	0.049
		1732.4	1412	22.25	0.019	0.047
		1752.6	1513	22.21	0.019	0.047
HSDPA	Subtest 1	1712.4	1312	22.41	0.020	0.049
		1732.4	1412	22.24	0.019	0.047
		1752.6	1513	22.23	0.019	0.047
	Subtest 2	1712.4	1312	22.36	0.019	0.049
		1732.4	1412	22.21	0.019	0.047
		1752.6	1513	22.22	0.019	0.047
	Subtest 3	1712.4	1312	22.35	0.019	0.048
		1732.4	1412	22.22	0.019	0.047
		1752.6	1513	22.21	0.019	0.047
	Subtest 4	1712.4	1312	22.34	0.019	0.048
		1732.4	1412	22.21	0.019	0.047
		1752.6	1513	22.21	0.019	0.047
HSUPA	Subtest 1	1712.4	1312	22.34	0.019	0.048
		1732.4	1412	22.22	0.019	0.047
		1752.6	1513	22.24	0.019	0.047
	Subtest 2	1712.4	1312	22.31	0.019	0.048
		1732.4	1412	22.23	0.019	0.047
		1752.6	1513	22.21	0.019	0.047
	Subtest 3	1712.4	1312	22.36	0.019	0.049
		1732.4	1412	22.23	0.019	0.047
		1752.6	1513	22.21	0.019	0.047
	Subtest 4	1712.4	1312	22.32	0.019	0.048
		1732.4	1412	22.21	0.019	0.047
		1752.6	1513	22.21	0.019	0.047
	Subtest 5	1712.4	1312	22.35	0.019	0.048
		1732.4	1412	22.23	0.019	0.047
		1752.6	1513	22.21	0.019	0.047
HSPA+	Subtest 1	1712.4	1312	22.39	0.019	0.049
		1732.4	1412	22.22	0.019	0.047
		1752.6	1513	22.21	0.019	0.047

Occupied Bandwidth-FCC 2.1049/ 27.53(h)(1)

WCDMA band II

REL99 Mode:

Carrier frequency (MHz)	Channel No.	Bandwidth of 99% Power (MHz)
1852.4	9262	4.1454
1880.0	9400	4.1417
1907.6	9538	4.1540

HSDPA Mode:

Carrier frequency (MHz)	Channel No.	Bandwidth of 99% Power (MHz)
1852.4	9262	4.1529
1880.0	9400	4.1378
1907.6	9538	4.1374

WCDMA band V

REL99 Mode:

Carrier frequency (MHz)	Channel No.	Bandwidth of 99% Power (MHz)
826.4	4132	4.1551
836.6	4183	4.1247
846.6	4233	4.1405

HSDPA Mode:

Carrier frequency (MHz)	Channel No.	Bandwidth of 99% Power (MHz)
826.4	4132	4.1360
836.6	4183	4.1205
846.6	4233	4.1265

WCDMA band IV

REL99 Mode:

Carrier frequency (MHz)	Channel No.	Bandwidth of 99% Power (MHz)
1712.4	1312	4.1195
1732.4	1412	4.1205
1752.6	1513	4.1265

HSDPA Mode:

Carrier frequency (MHz)	Channel No.	Bandwidth of 99% Power (MHz)
1712.4	1312	4.1345
1732.4	1412	4.1313
1752.6	1513	4.1485

Emission Bandwidth-FCC 22.917(b)/24.238(b)

WCDMA band II

REL99 Mode:

Carrier frequency (MHz)	Channel No.	Bandwidth of -26dBc Power (MHz)
1852.4	9262	4.653
1880.0	9400	4.678
1907.6	9538	4.693

HSDPA Mode:

Carrier frequency (MHz)	Channel No.	Bandwidth of -26dBc Power (MHz)
1852.4	9262	4.667
1880.0	9400	4.649
1907.6	9538	4.666

WCDMA band V

REL99 Mode:

Carrier frequency (MHz)	Channel No.	Bandwidth of -26dBc Power (MHz)
826.4	4132	4.729
836.6	4183	4.676
846.6	4233	4.701

HSDPA:

Carrier frequency (MHz)	Channel No.	Bandwidth of -26dBc Power (MHz)
826.4	4132	4.722
836.6	4183	4.705
846.6	4233	4.700

WCDMA band IV

REL99 Mode:

Carrier frequency (MHz)	Channel No.	Bandwidth of -26dBc Power (MHz)
1712.4	1312	4.675
1732.4	1412	4.666
1752.6	1513	4.675

HSDPA Mode:

Carrier frequency (MHz)	Channel No.	Bandwidth of -26dBc Power (MHz)
1712.4	1312	4.690
1732.4	1412	4.675
1752.6	1513	4.664

WCDMA band II

REL99 Mode:

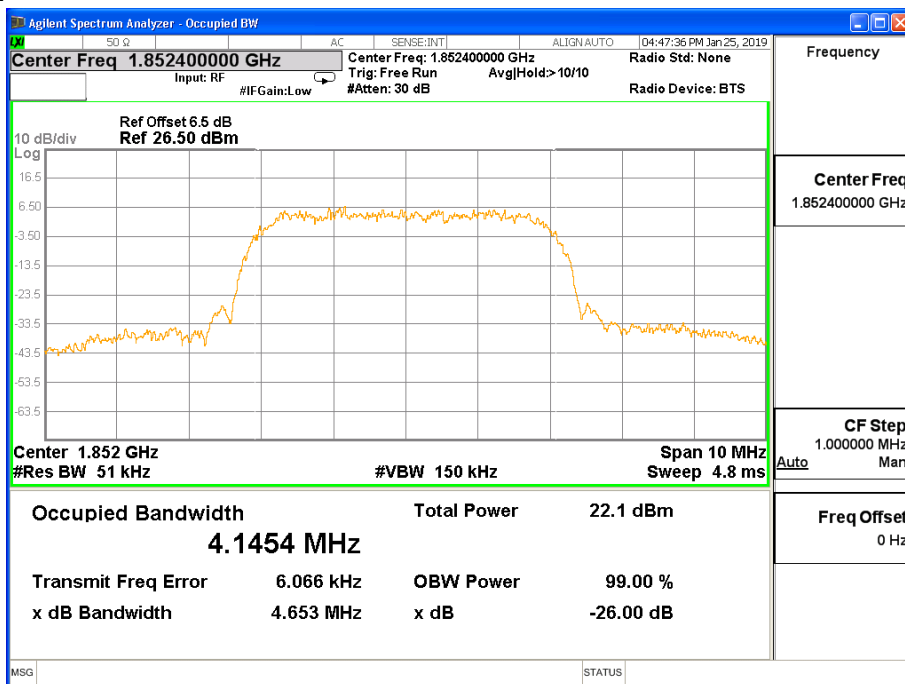

Channel 9262

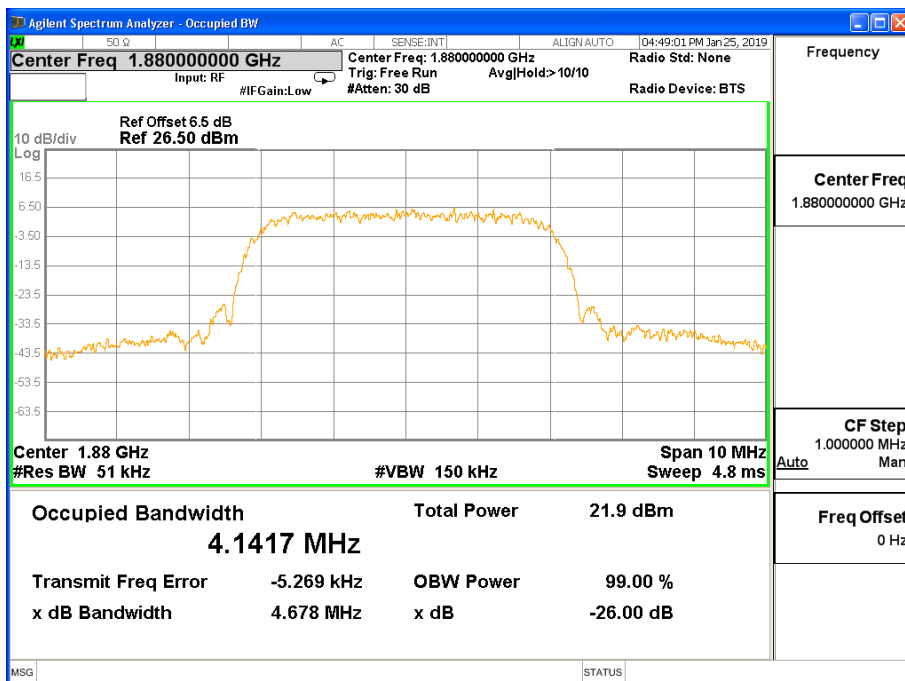

Channel 9400

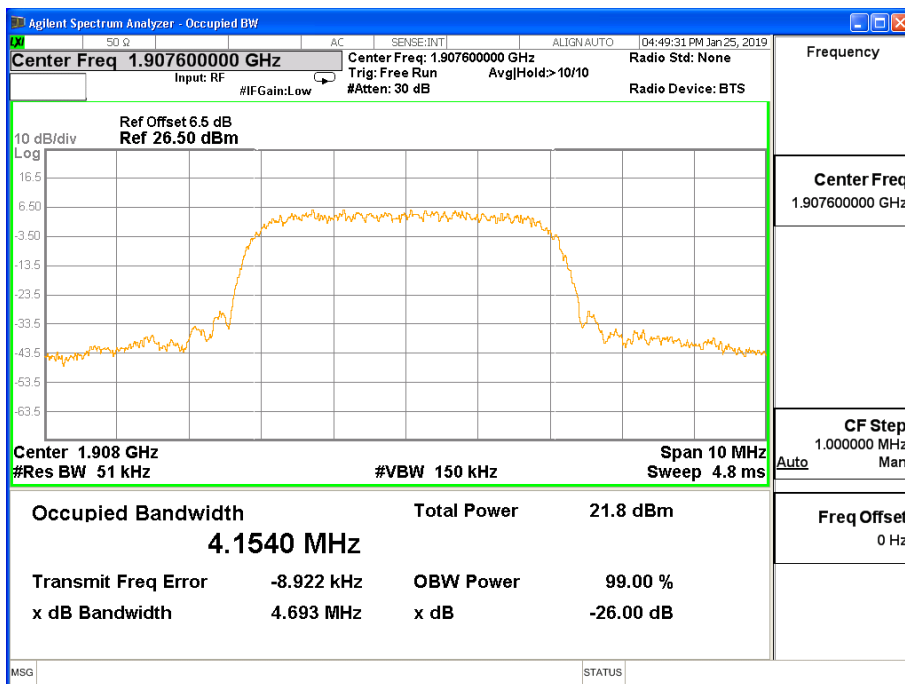

Channel 9538

HSDPA Mode:

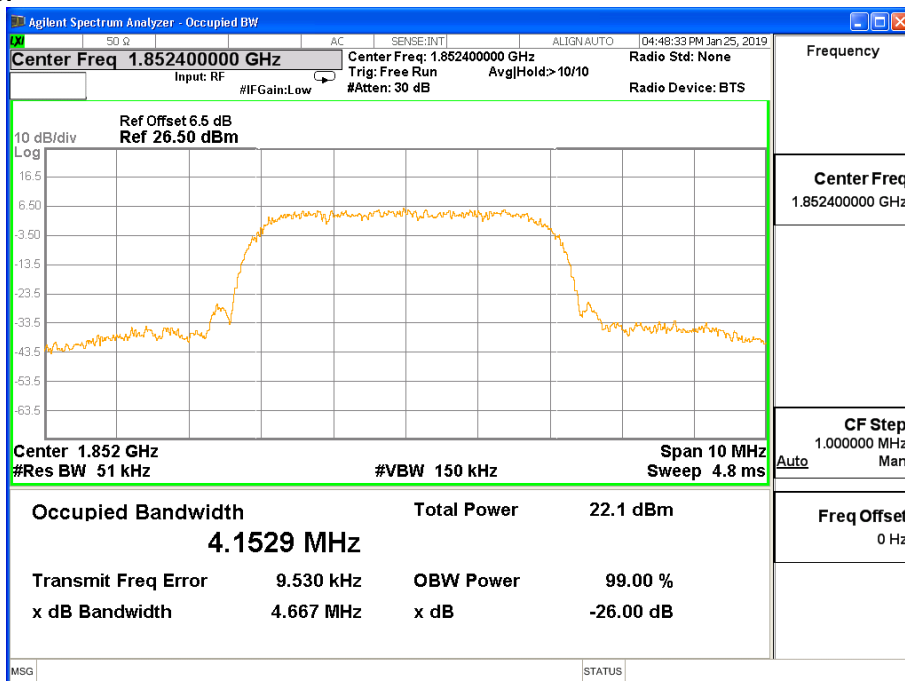

Channel 9262

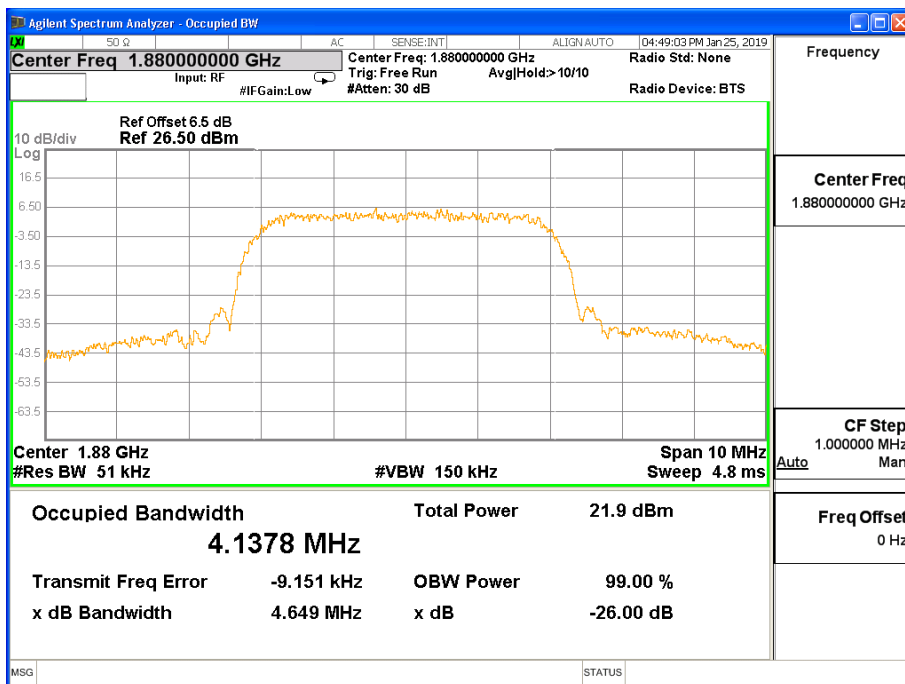

Channel 9400

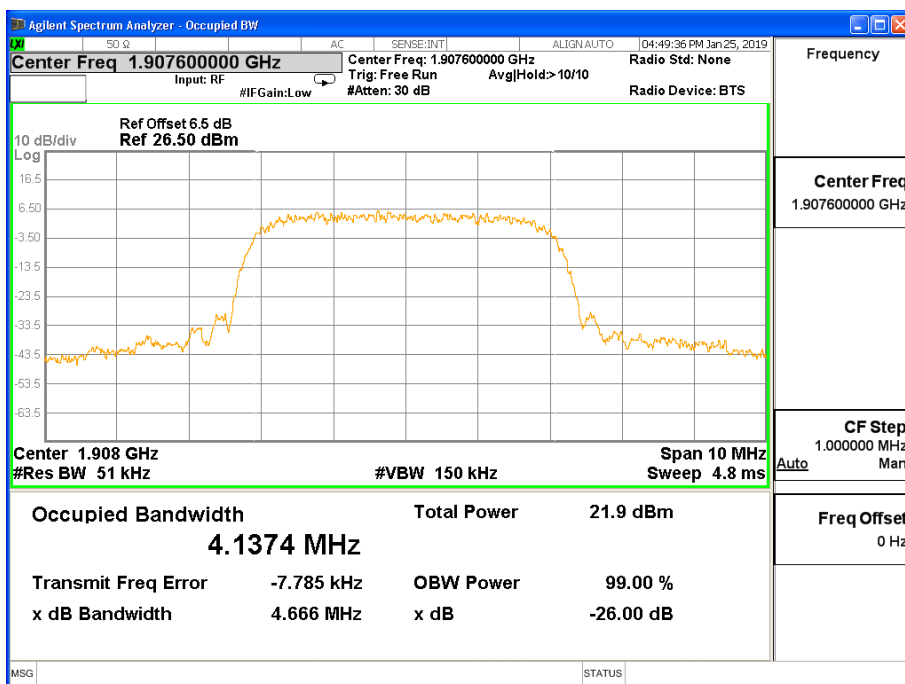

Channel 9538

WCDMA band V

REL99 Mode:

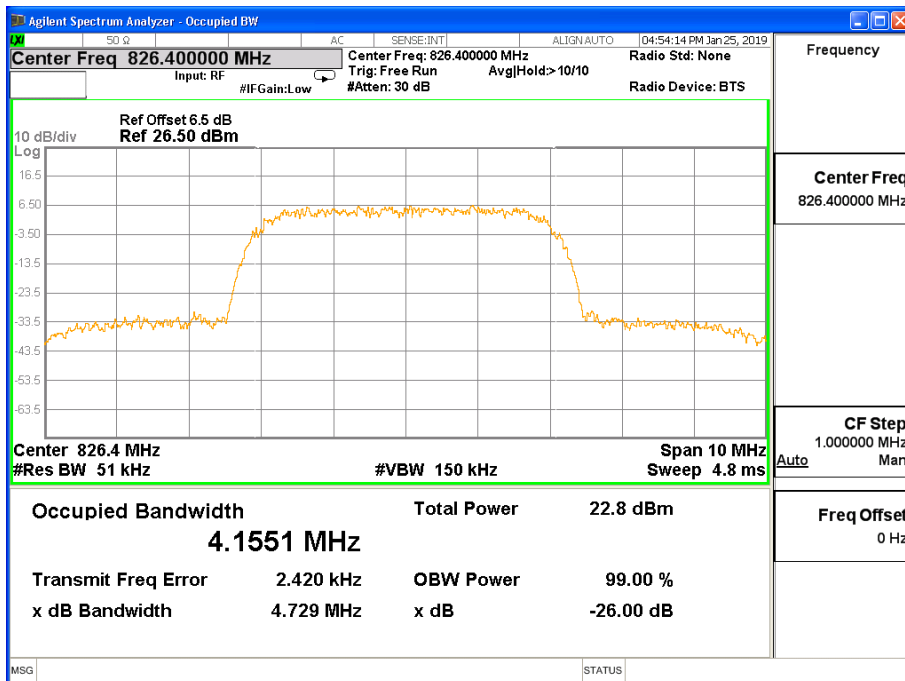

Channel 4132

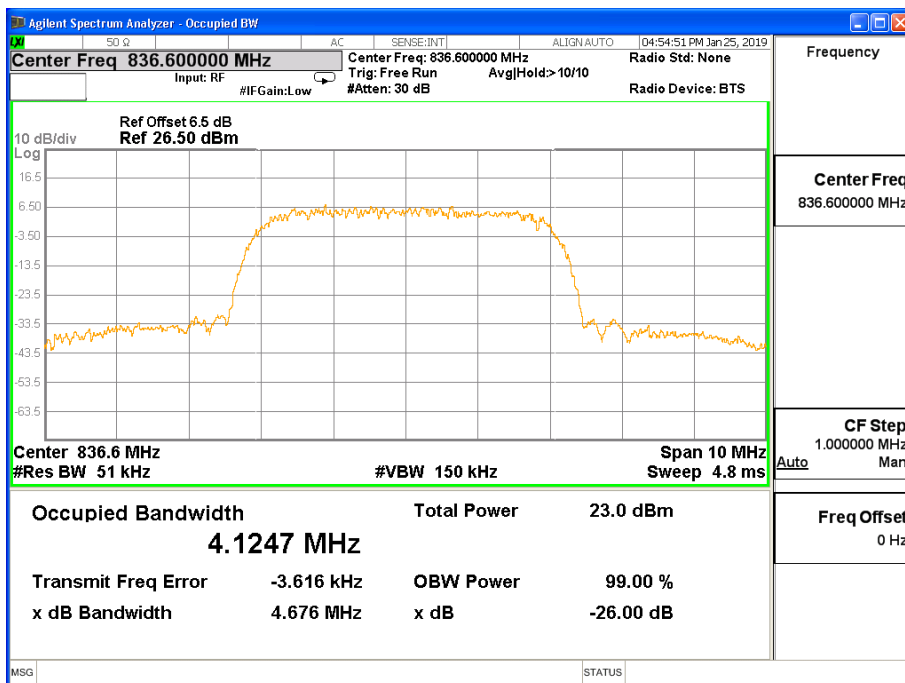

Channel 4183

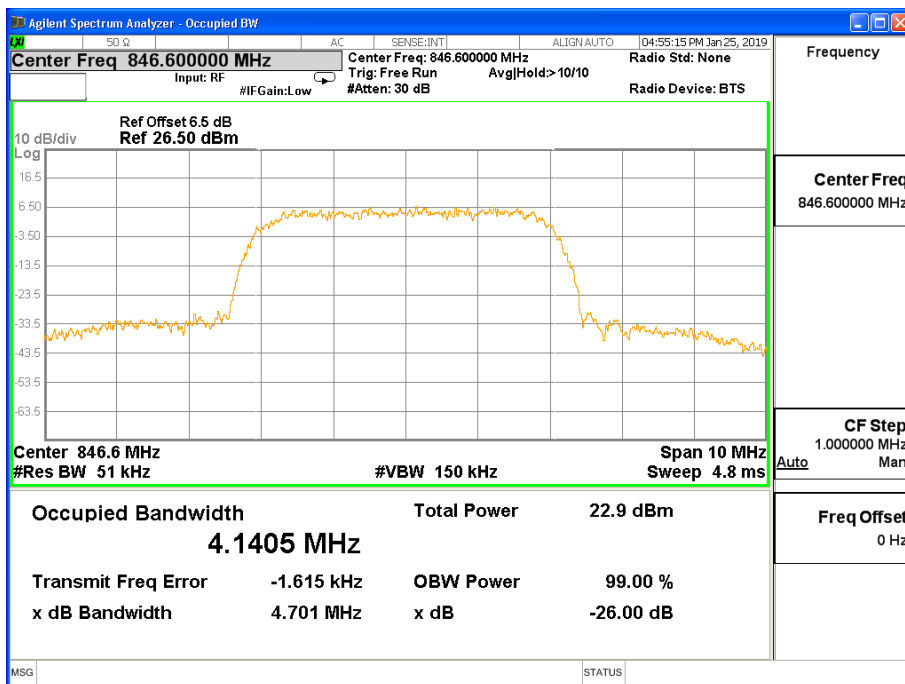

Channel 4233

HSDPA:

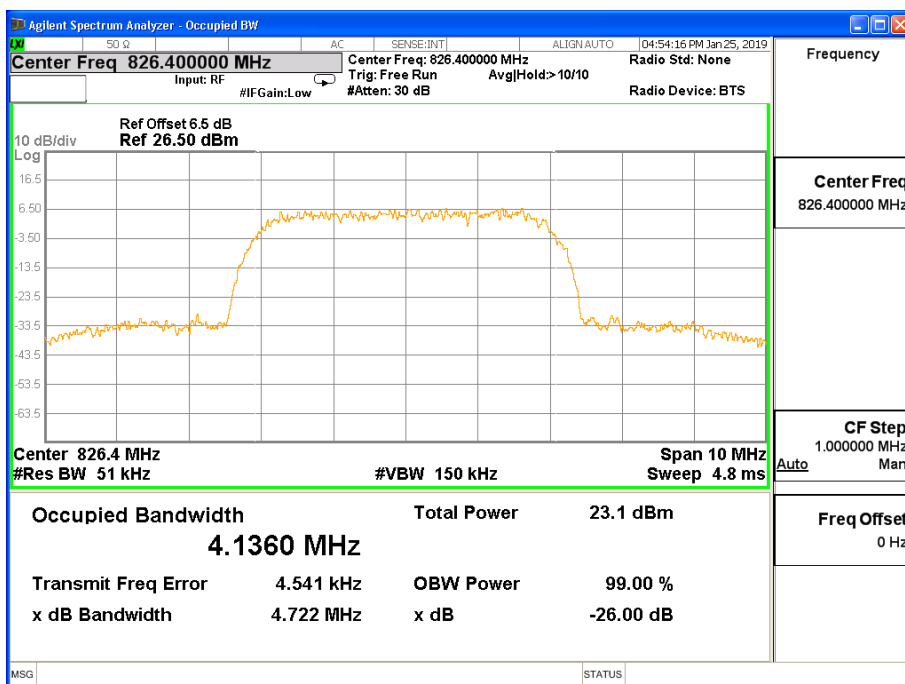

Channel 4132

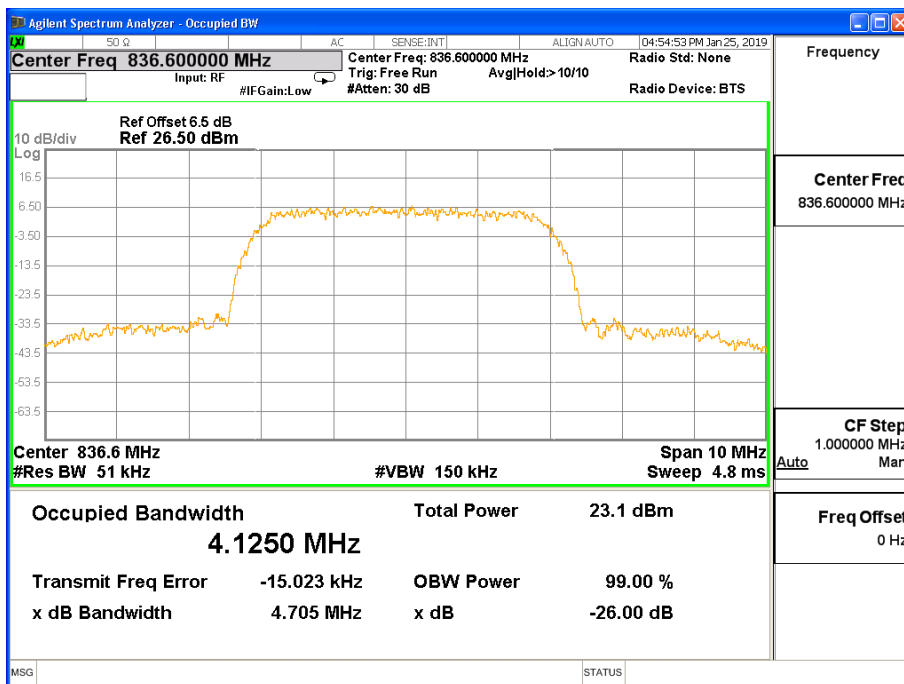

Channel 4183

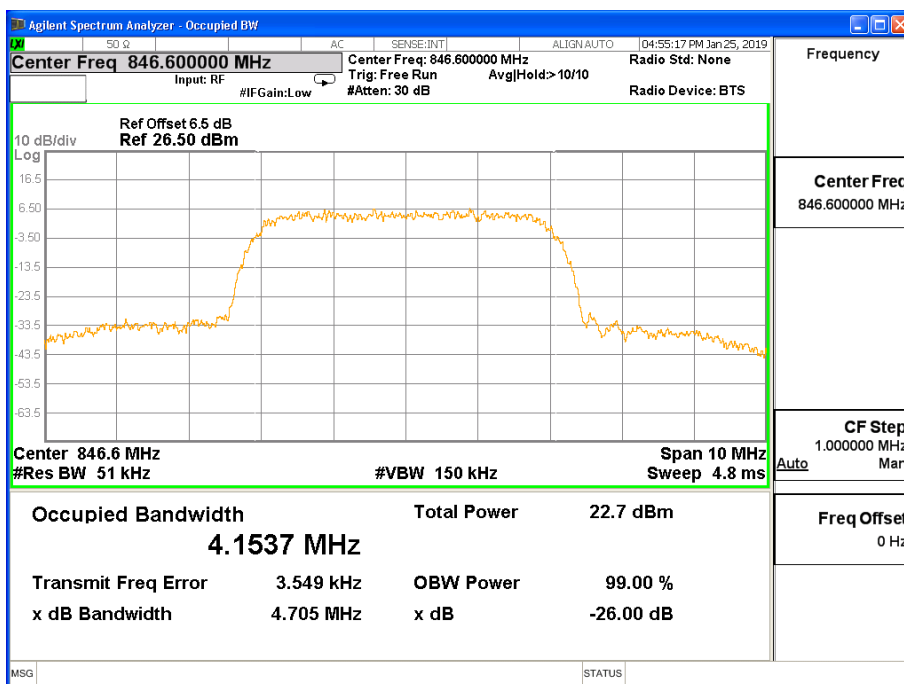

Channel 4233

WCDMA band IV

REL99 Mode:

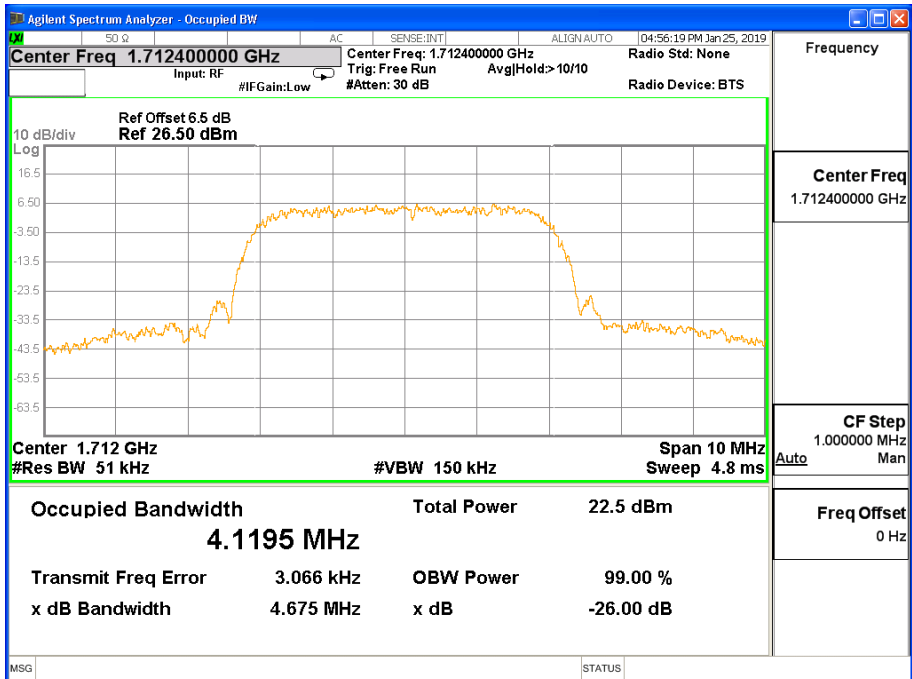

Channel 1312

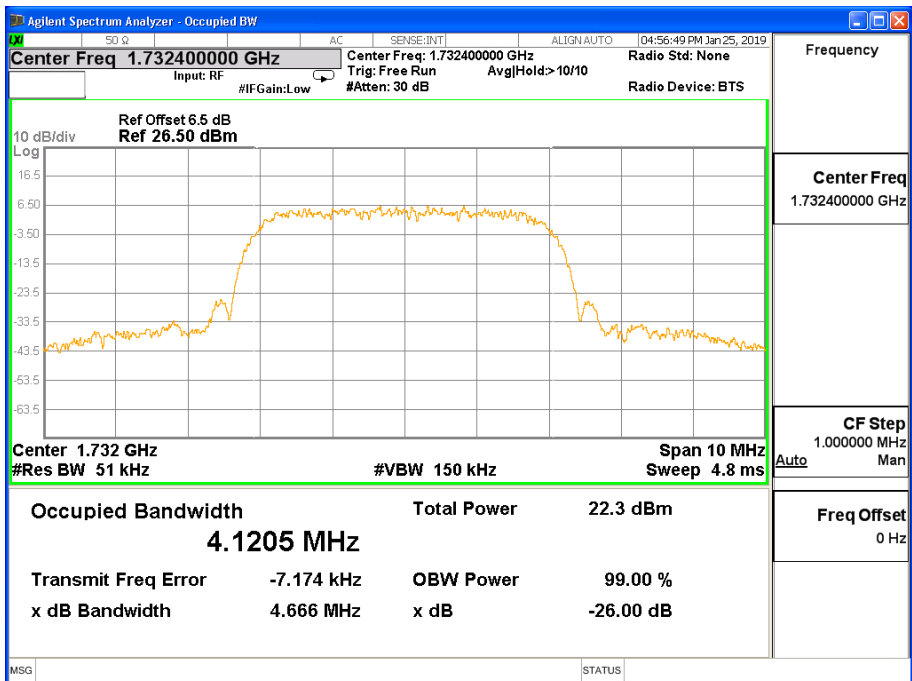

Channel 1412

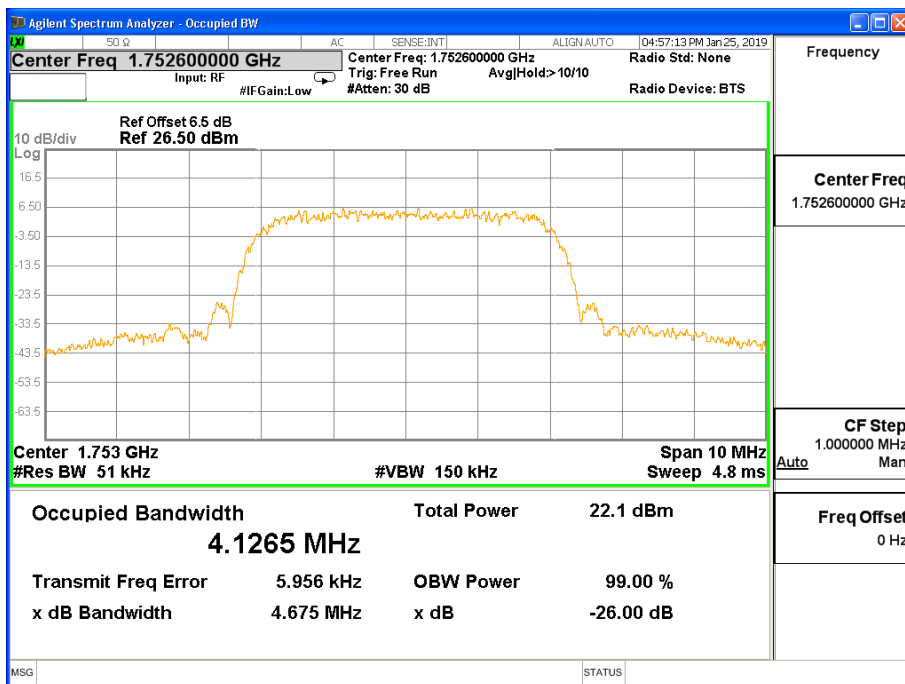

Channel 1513

HSDPA Mode:

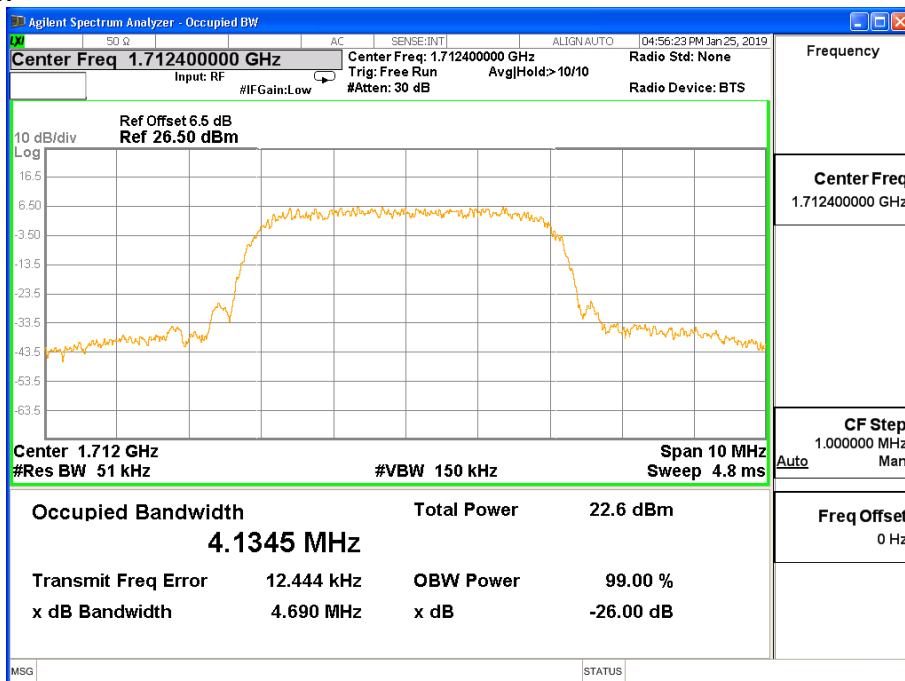

Channel 1312

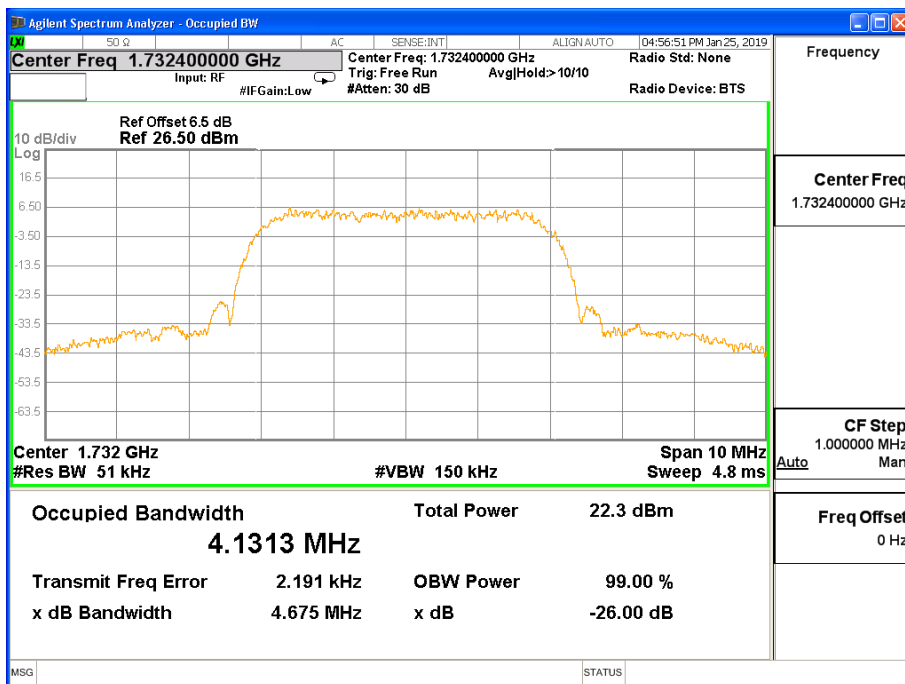

Channel 1412

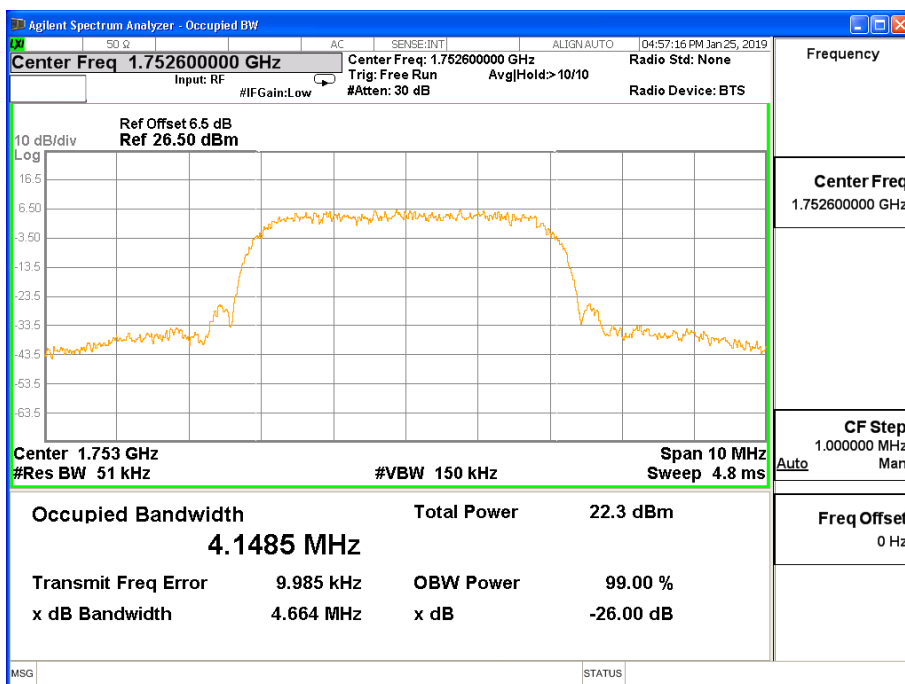

Channel 1513

Spurious Emissions at antenna terminal-FCC Part2.1051/ 22.917(a)/24.238(a)/ 27.53(h)
WCDMA band II

REL99 Mode:

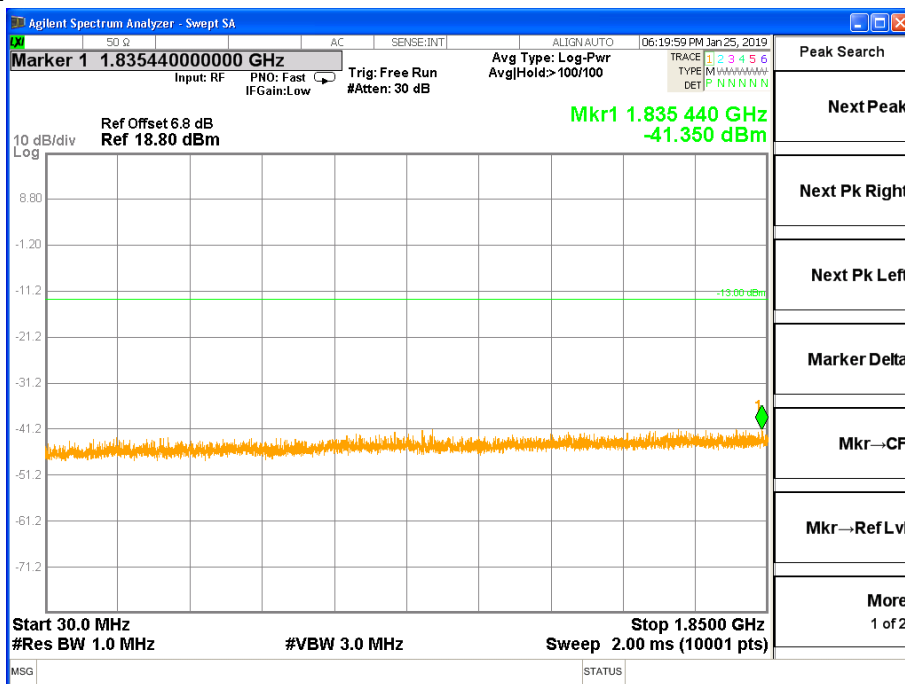

Channel 9400, 30MHz~1850MHz

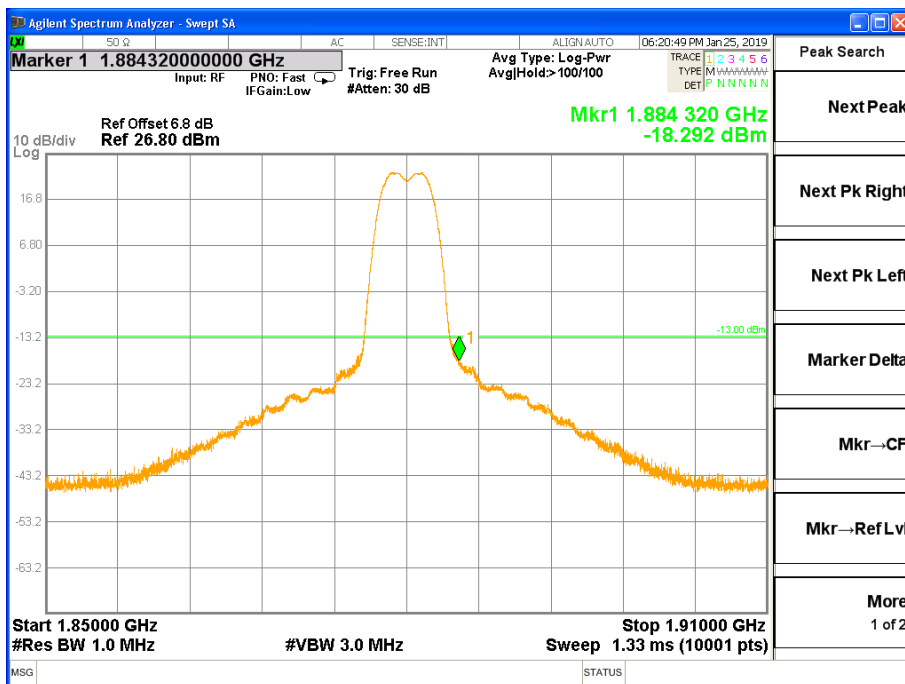

Channel 9400, 1850MHz~1910MHz

Note: The signal beyond the limit is the signal transmitted by EUT.

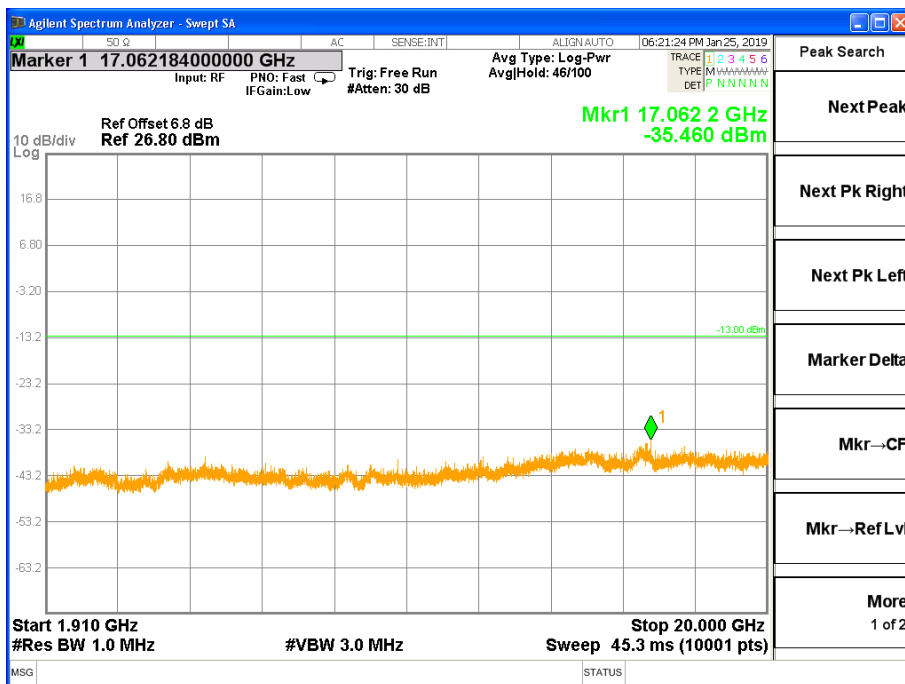

Channel 9400, 1910MHz~20GHz

HSDPA Mode:

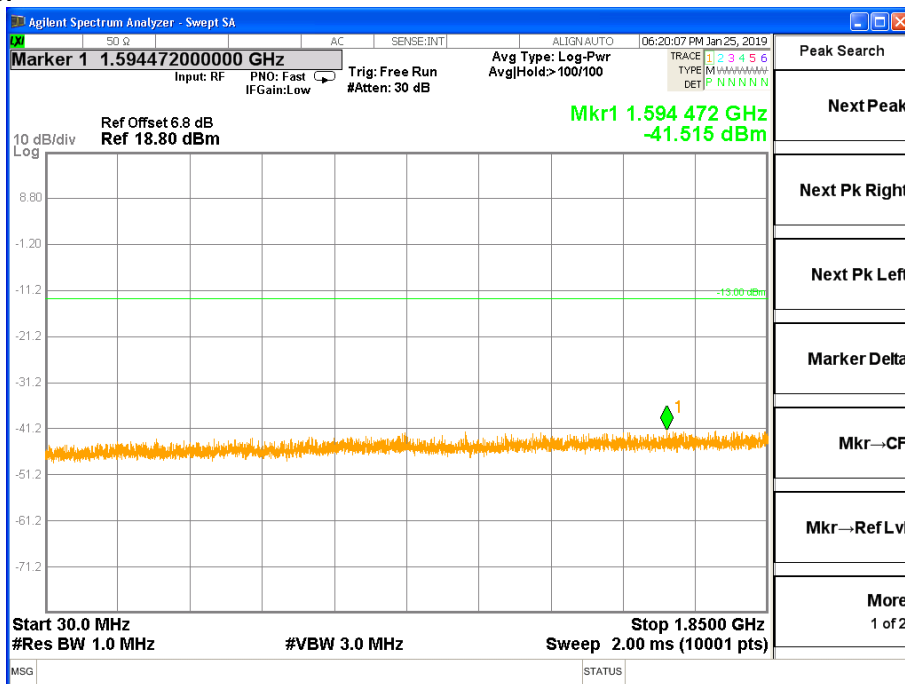

Channel 9400, 30MHz~1850MHz

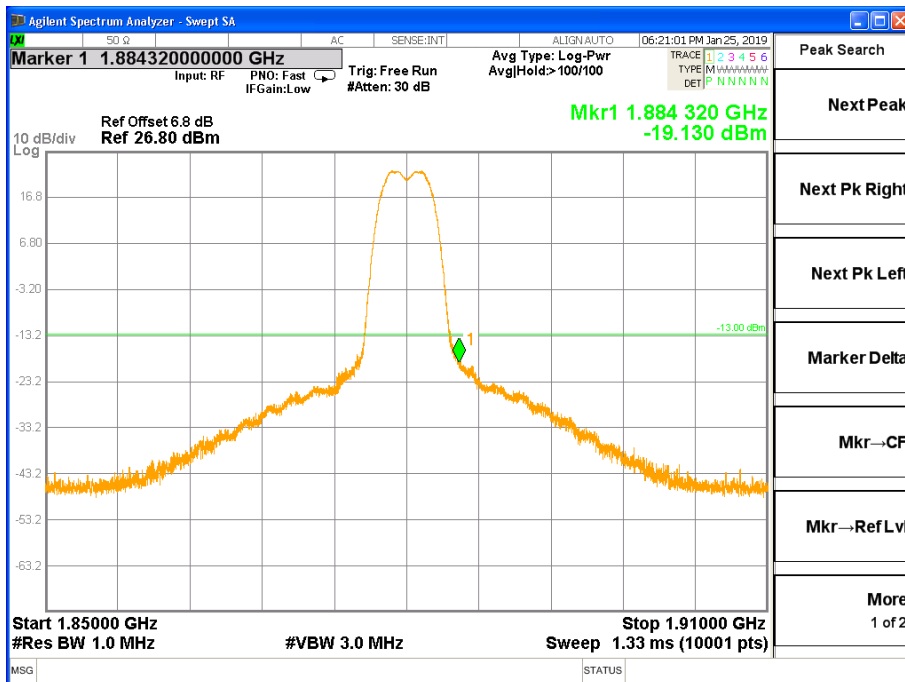

Channel 9400, 1850MHz~1910MHz

Note: The signal beyond the limit is the signal transmitted by EUT.

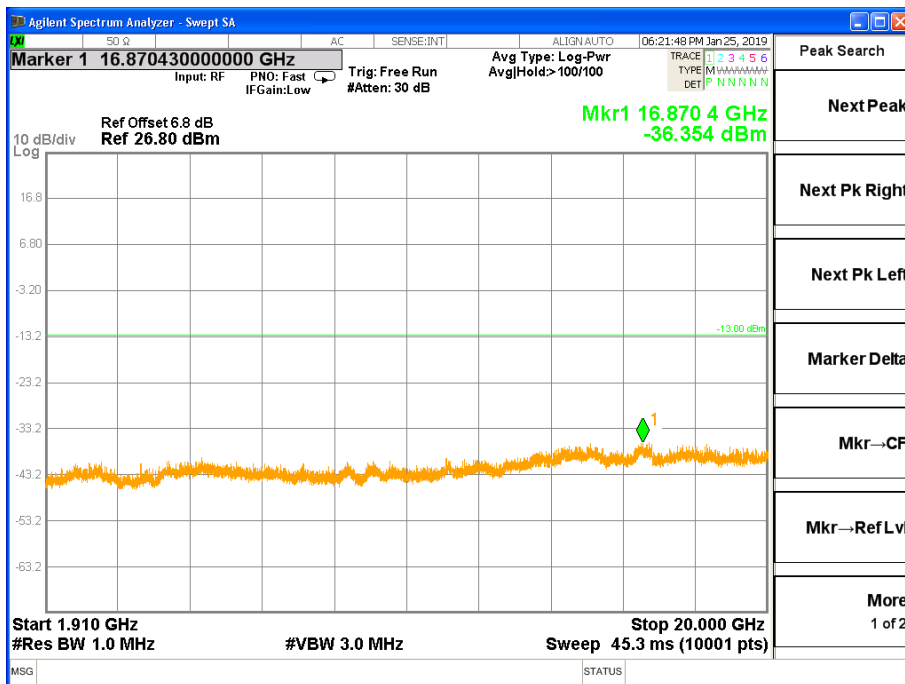

Channel 9400, 1910MHz~20GHz

WCDMA band V

REL99 Mode:

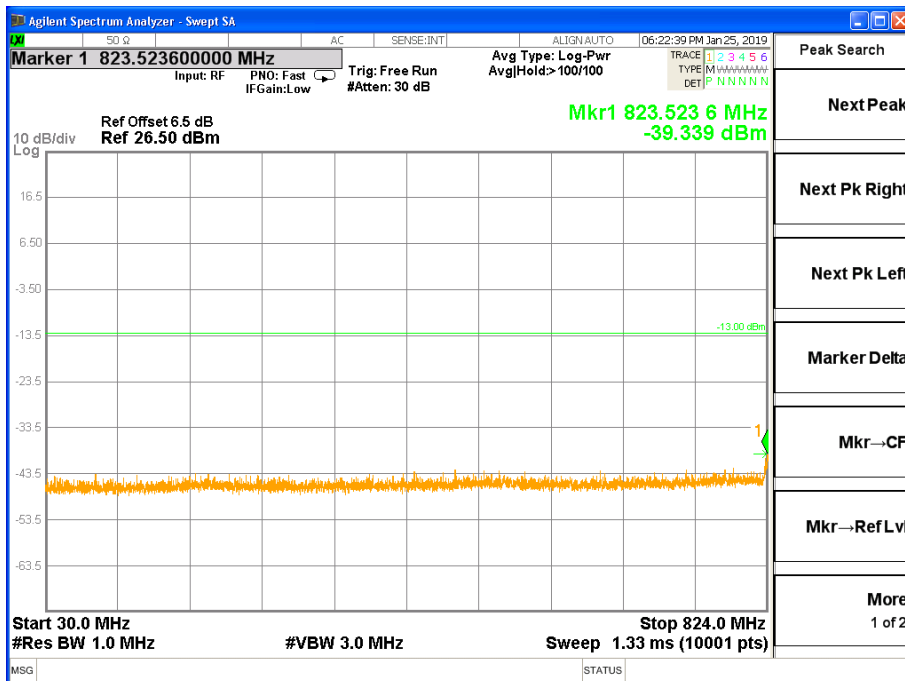

Channel 4183, 30MHz~824MHz

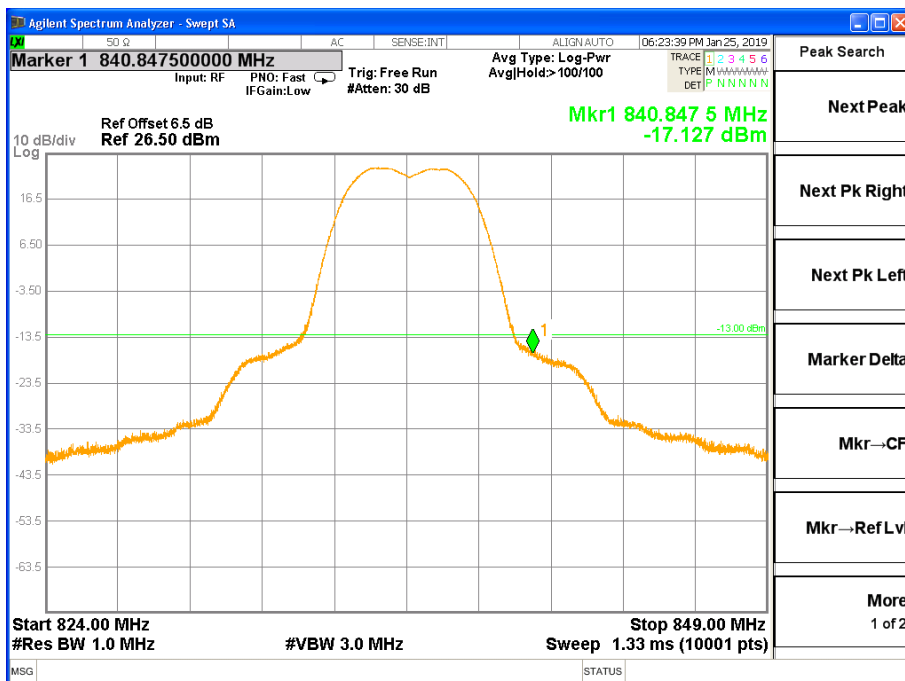

Channel 4183, 824MHz~849MHz

Note: The signal beyond the limit is the signal transmitted by EUT.

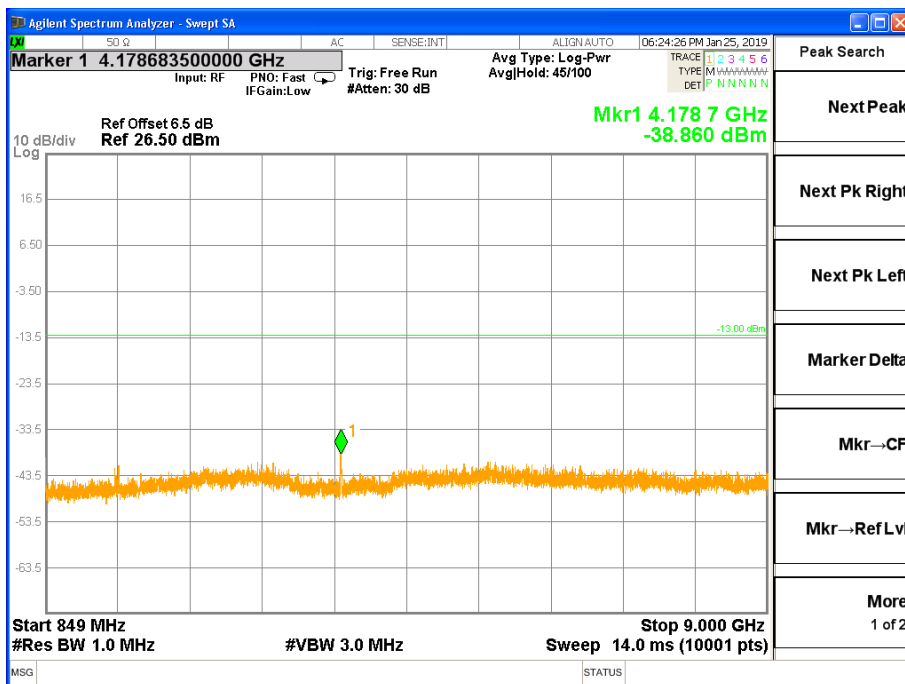

Channel 4183, 849MHz~9GHz

HSDPA Mode:

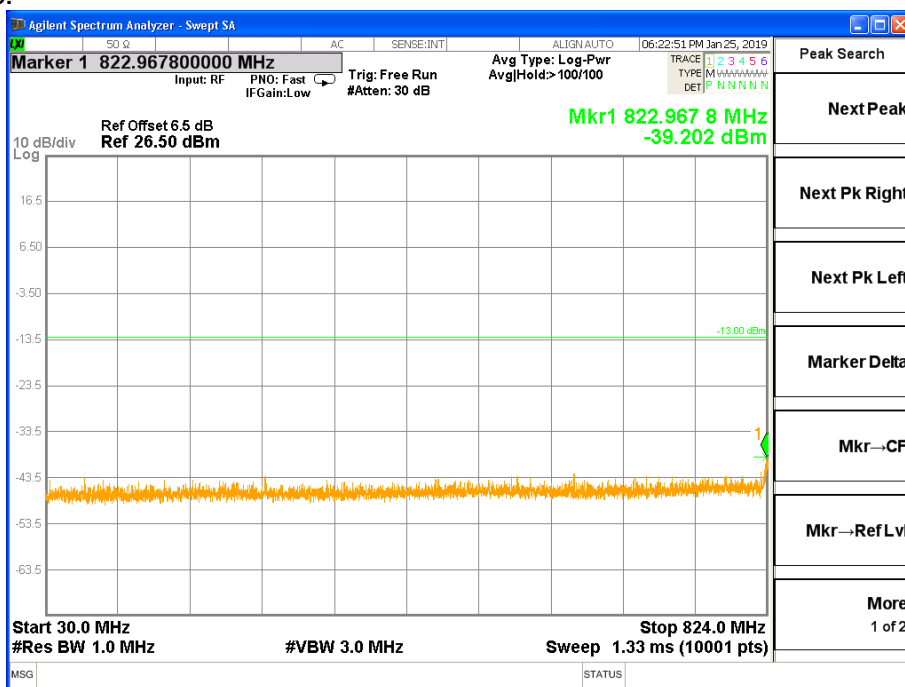

Channel 4183, 30MHz~824MHz

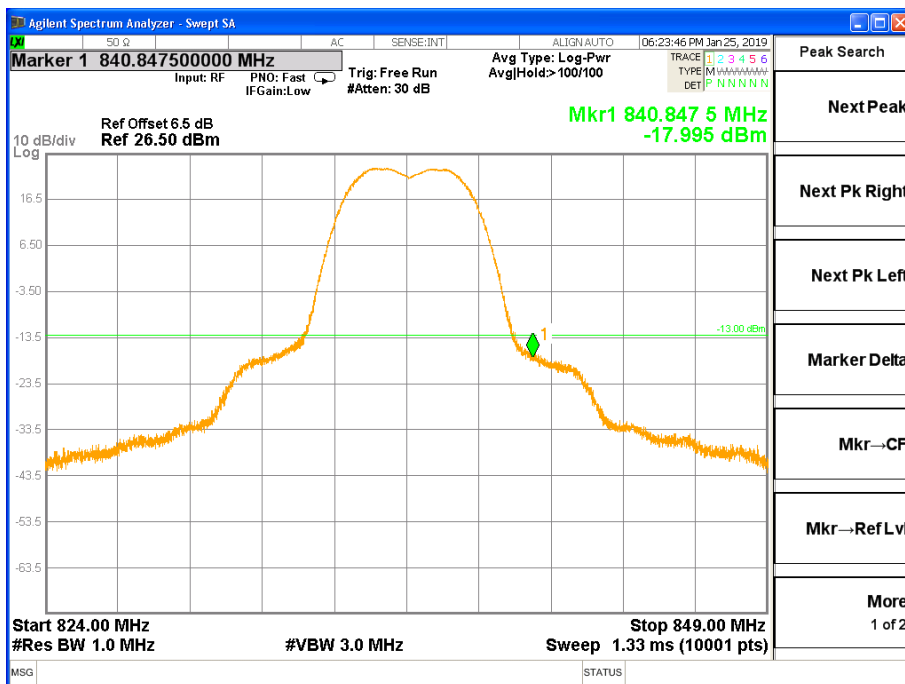

Channel 4183, 824MHz~849MHz

Note: The signal beyond the limit is the signal transmitted by EUT.

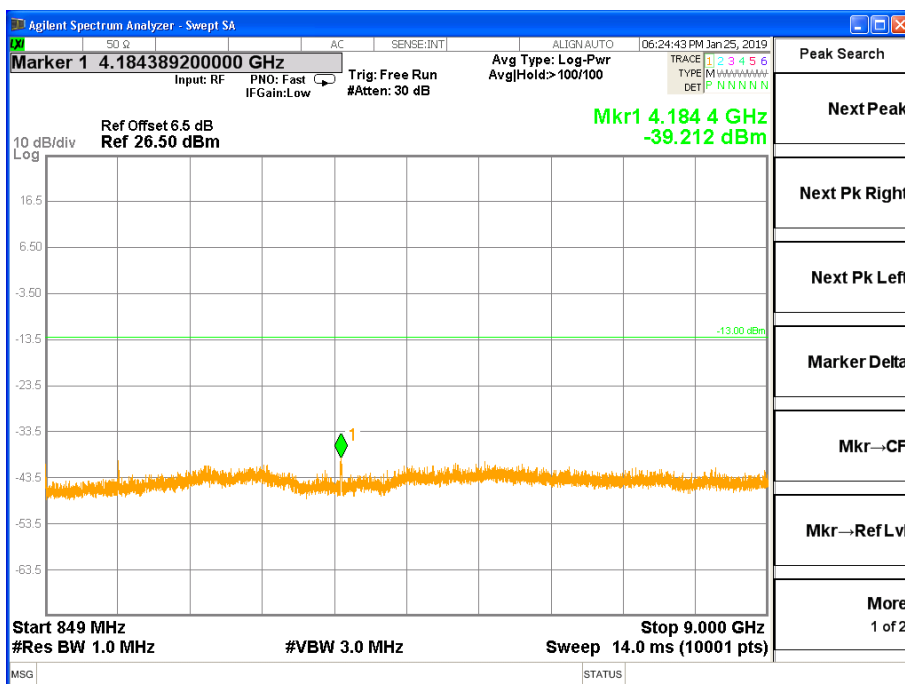

Channel 4183, 849MHz~9GHz

WCDMA band IV
REL99 Mode:

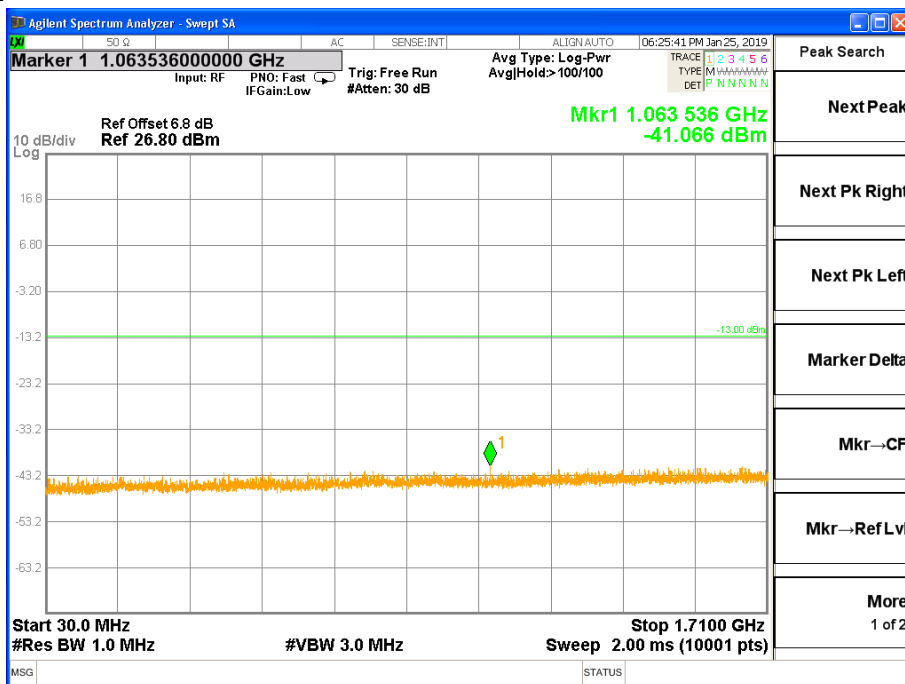

Channel 1412, 30MHz~1710MHz

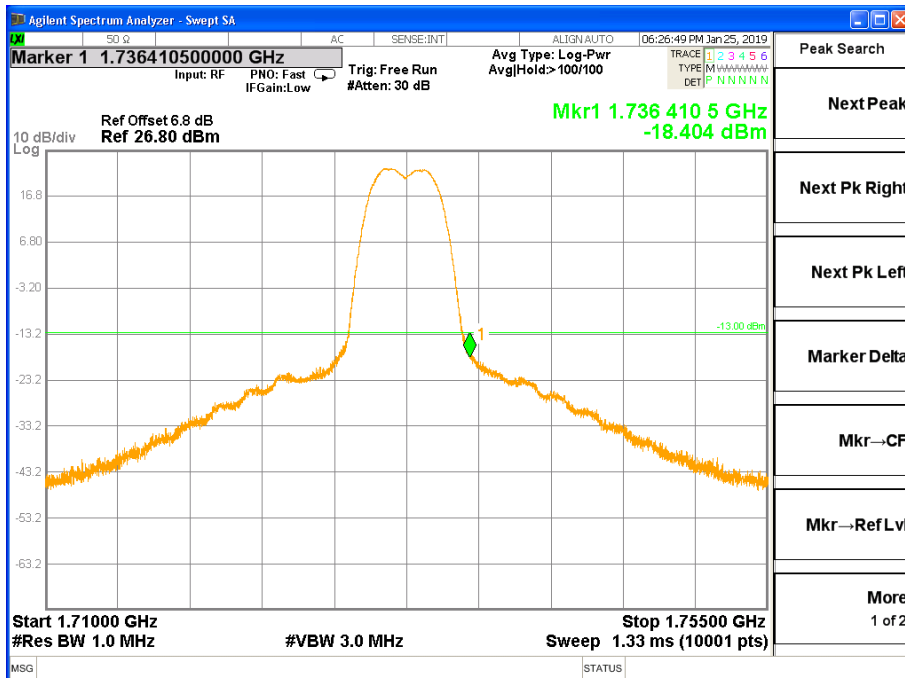

Channel 1412, 1710MHz~1755MHz

Note: The signal beyond the limit is the signal transmitted by EUT.

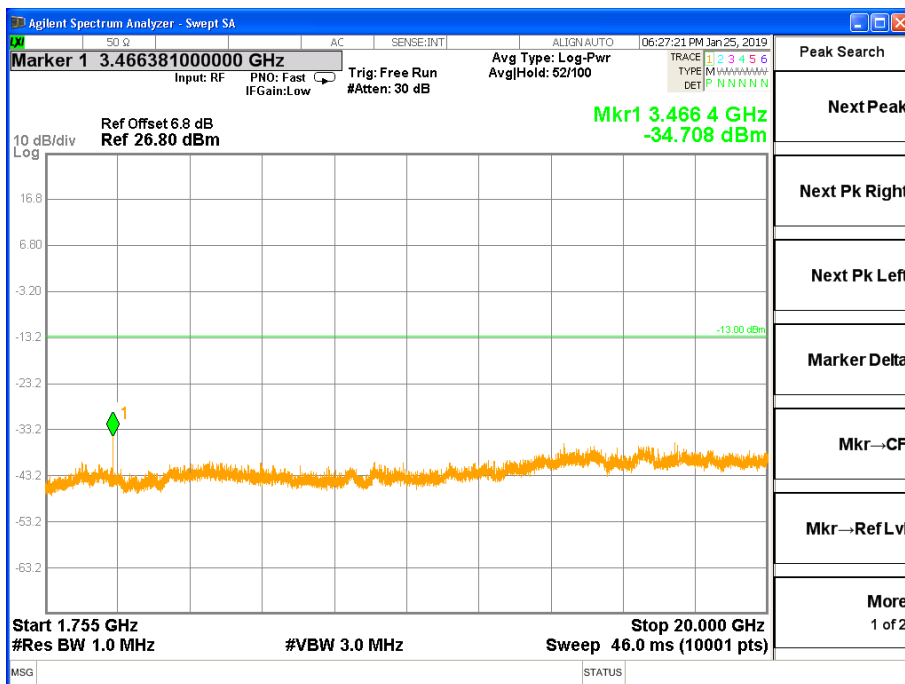

Channel 1412, 1755MHz~20GHz

HSDPA Mode:

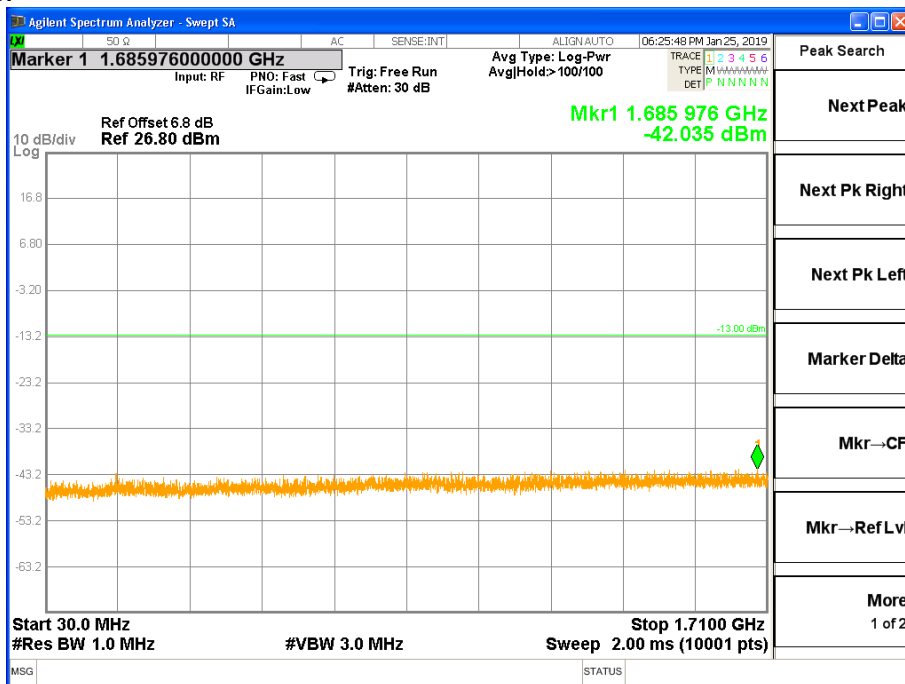

Channel 1412, 30MHz~1710MHz

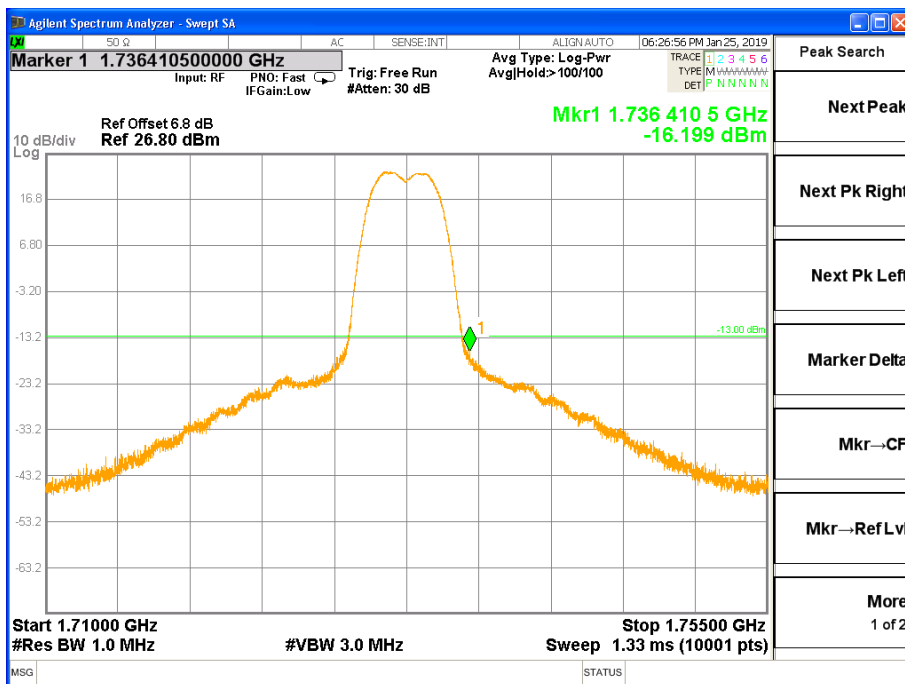

Channel 1412, 1710MHz~1755MHz

Note: The signal beyond the limit is the signal transmitted by EUT.

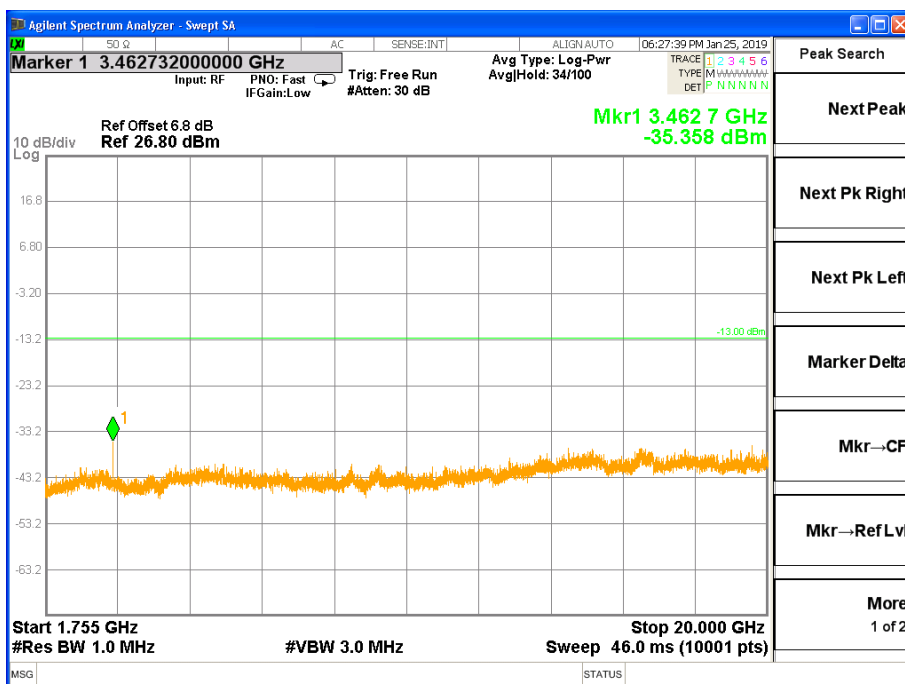

Channel 1412, 1755MHz~20GHz

Band Edges Compliance-FCC 22.917(b)/24.238(b)/ 27.53(h)

WCDMA band II

REL99 Mode:

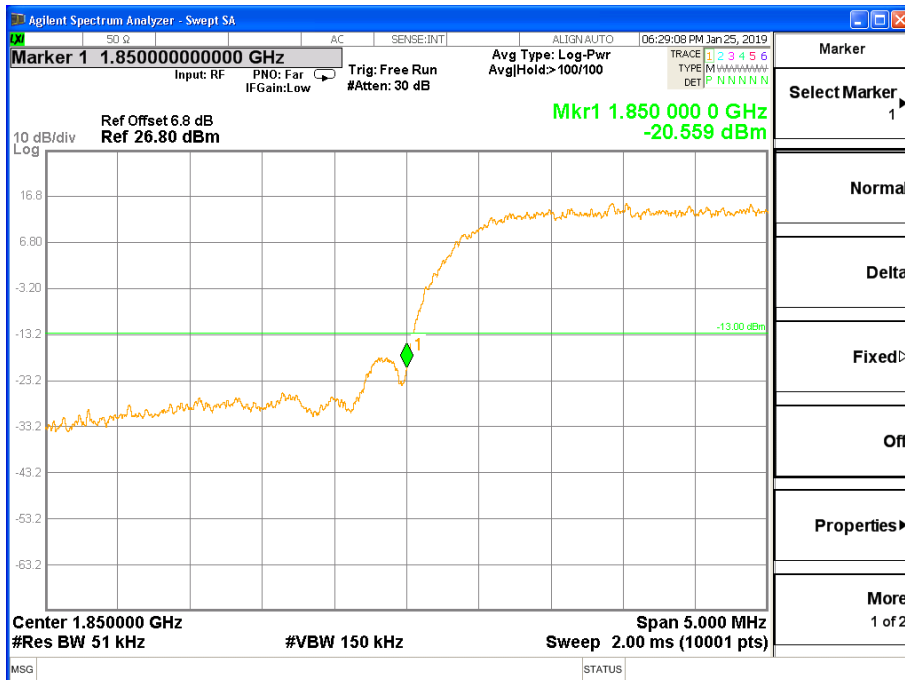

Channel 9262

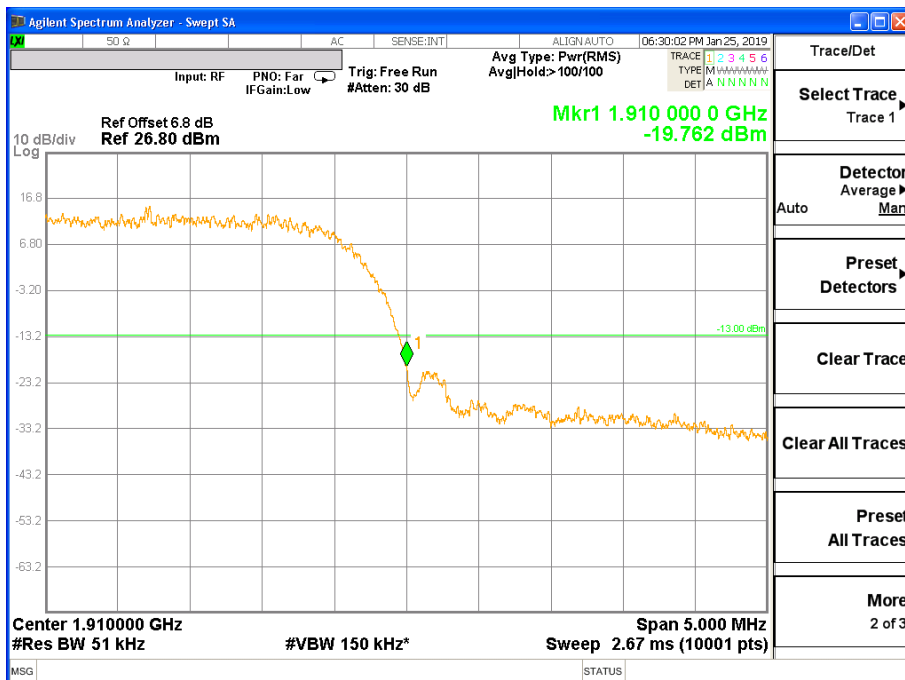

Channel 9538

HSDPA Mode:

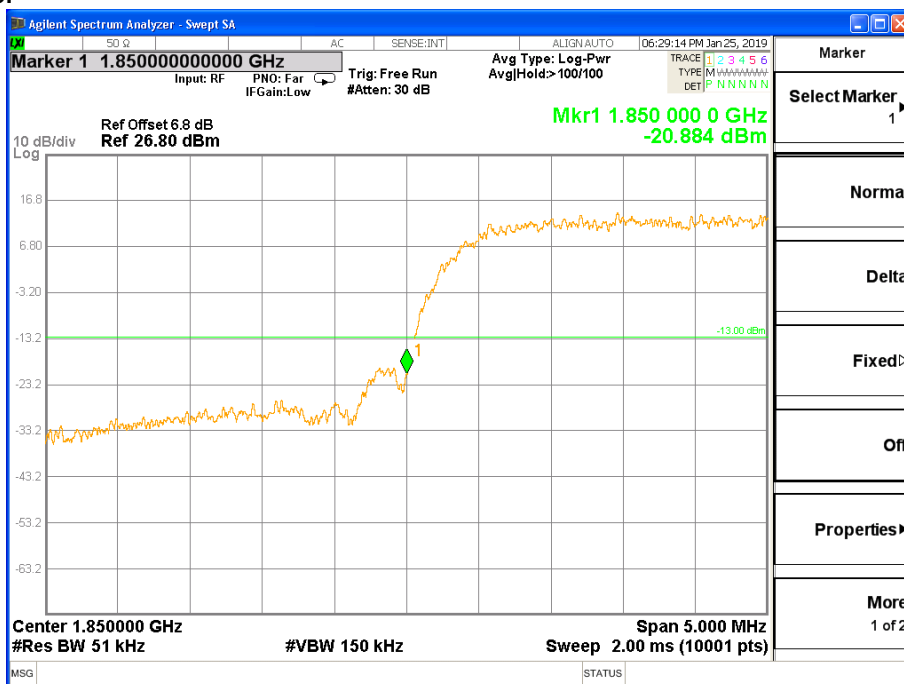

Channel 9262

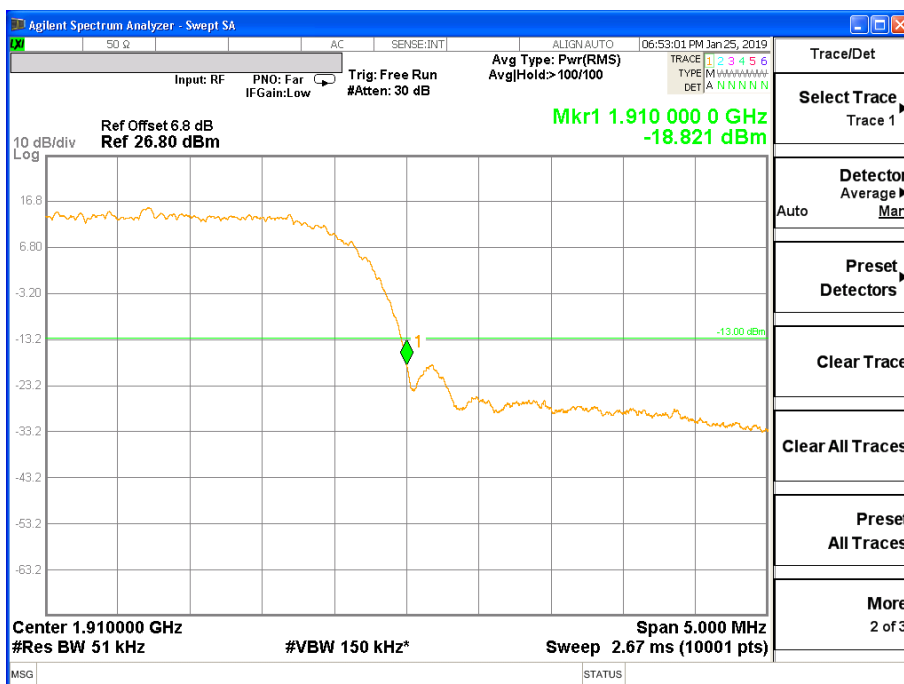

Channel 9538

WCDMA band V

REL99 Mode:

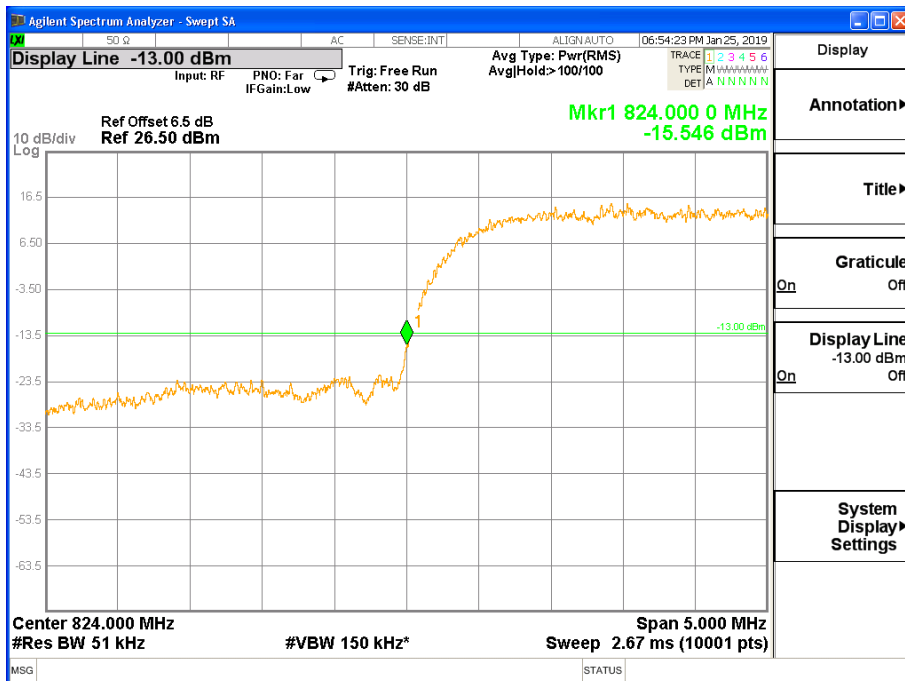

Channel 4132

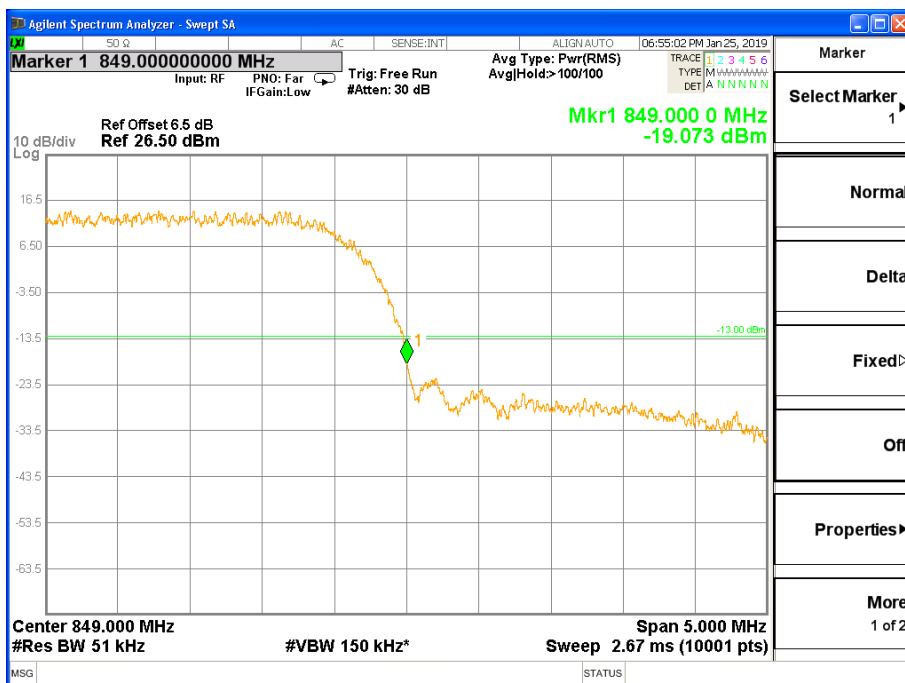

Channel 4233

HSDPA Mode:

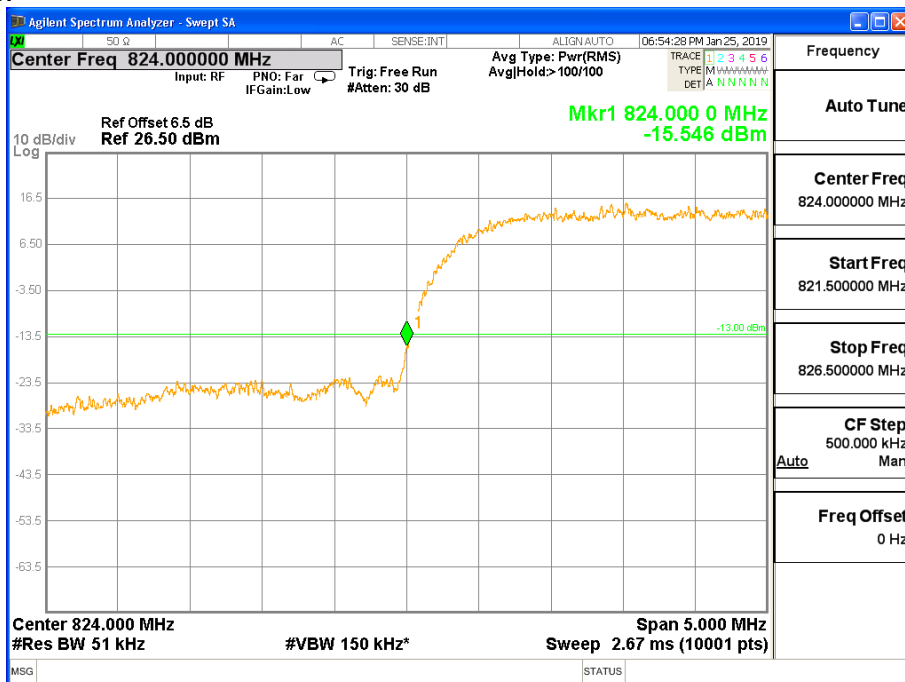

Channel 4132

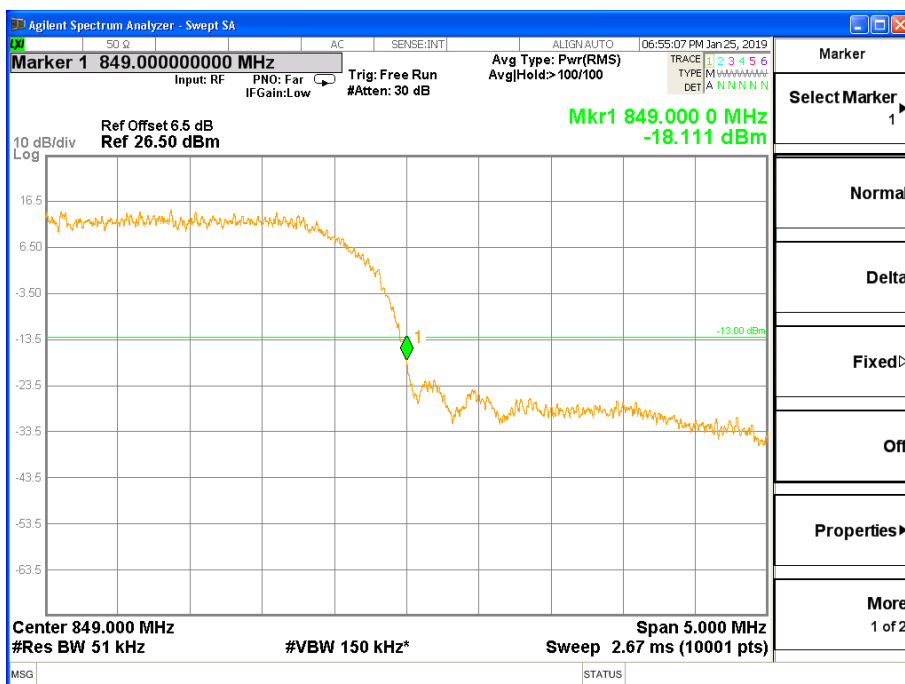

Channel 4233

WCDMA band IV

REL99 Mode:

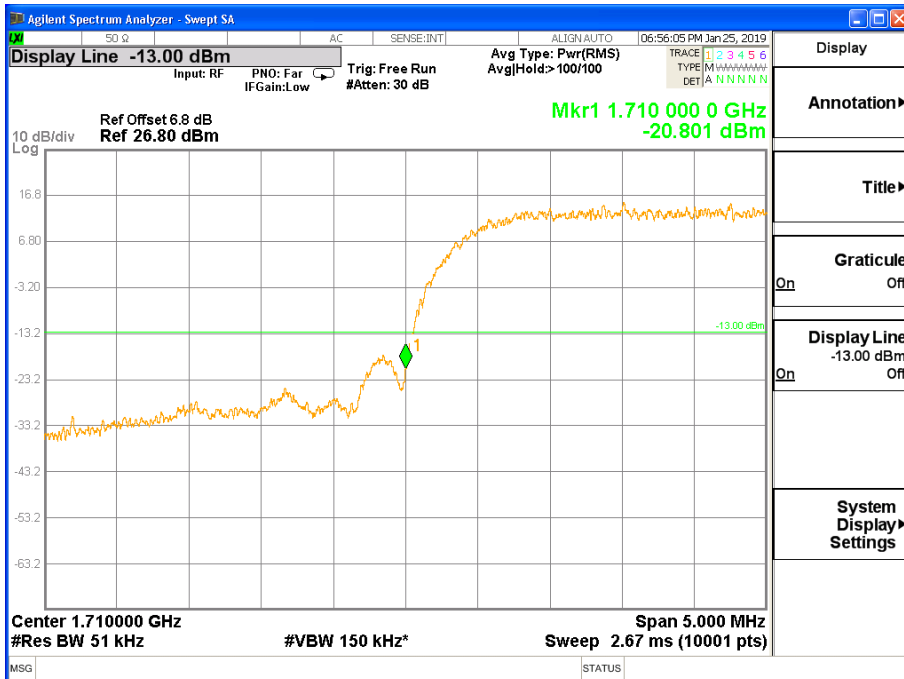

Channel 1312

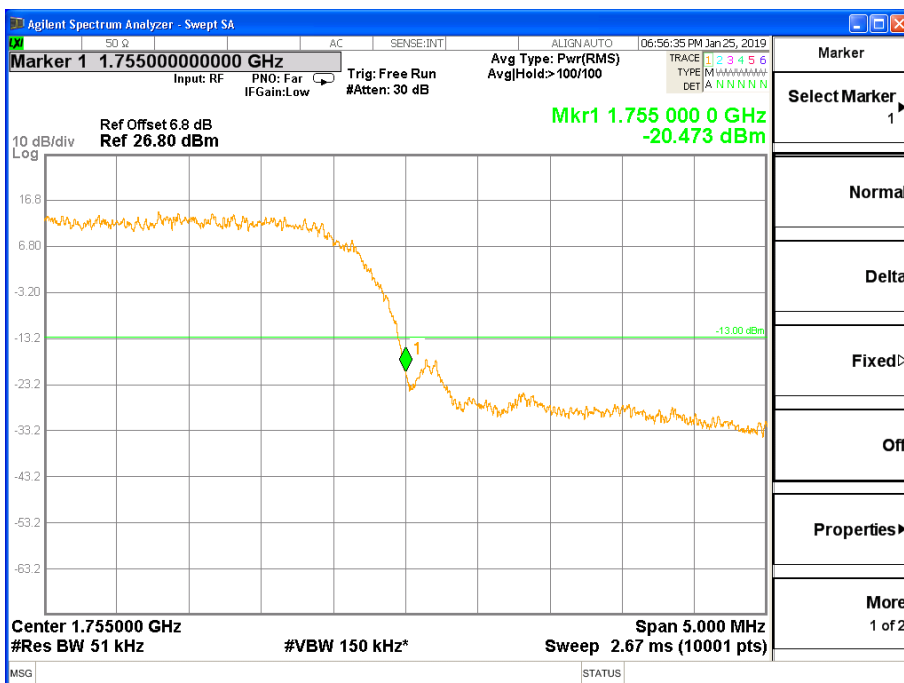

Channel 1513

HSDPA Mode:

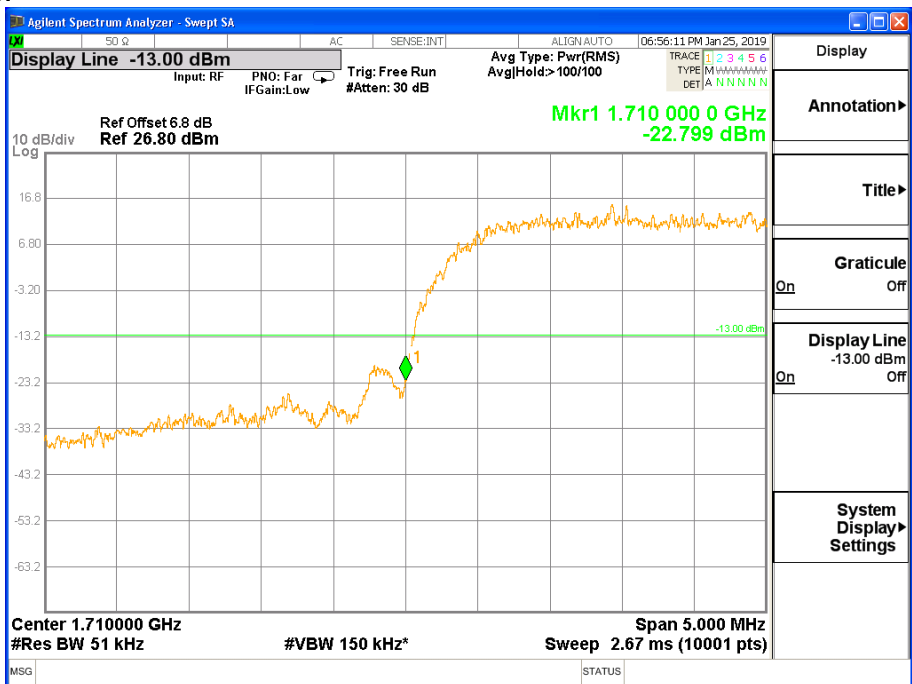

Channel 1312

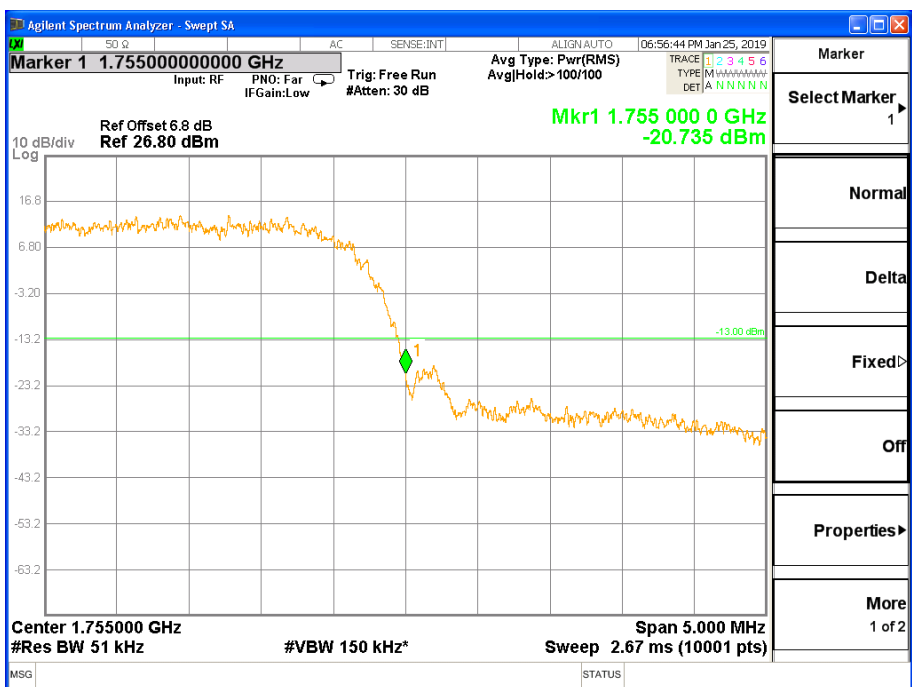

Channel 1513

Frequency Stability-FCC Part2.1055/22.355/24.235/27.54

WCDMA band II

REL99 Mode:

Temperature(°C)	Test Result (ppm)@NV		
	Channel 9262	Channel 9400	Channel 9538
0	0.013	0.017	-0.015
+10	0.010	-0.016	0.015
+20	0.019	0.017	0.003
+30	-0.011	0.004	0.011
+35	0.018	0.011	-0.015
Voltage	Test Result (ppm)@NT		
	Channel 9262	Channel 9400	Channel 9538
LV	0.002	0.003	0.004
HV	0.004	0.004	0.002

HSDPA Mode:

Temperature(°C)	Test Result (ppm)@NV		
	Channel 9262	Channel 9400	Channel 9538
0	0.003	-0.010	0.017
+10	0.008	0.017	0.011
+20	-0.008	0.007	0.006
+30	0.011	0.015	0.016
+35	0.004	0.015	-0.016
Voltage	Test Result (ppm)NT		
	Channel 9262	Channel 9400	Channel 9538
LV	0.008	0.011	0.003
HV	0.006	0.002	0.008

WCDMA band V
REL99 Mode:

Temperature(°C)	Test Result (ppm)@NV		
	Channel 4132	Channel 4183	Channel 4233
0	0.017	0.001	0.004
+10	0.011	-0.001	-0.018
+20	-0.007	0.008	0.009
+30	0.010	0.009	0.005
+35	0.002	-0.008	-0.002

Voltage	Test Result (ppm)@NT		
	Channel 4132	Channel 4183	Channel 4233
LV	0.009	-0.003	0.008
HV	0.004	0.005	0.007

HSDPA Mode:

Temperature(°C)	Test Result (ppm)@NV		
	Channel 4132	Channel 4183	Channel 4233
0	0.004	0.004	0.008
+10	-0.014	0.020	-0.008
+20	0.020	-0.004	0.019
+30	0.018	0.006	0.008
+35	0.016	0.014	0.002

Voltage	Test Result (ppm)@NT		
	Channel 4132	Channel 4183	Channel 4233
LV	0.015	-0.004	0.006
HV	0.002	0.008	-0.003

WCDMA band IV

REL99 Mode:

Temperature(°C)	Test Result (ppm)@NV		
	Channel 1312	Channel 1412	Channel 1513
0	0.003	0.018	-0.006
+10	0.019	-0.009	0.018
+20	-0.001	0.009	0.017
+30	0.016	0.001	0.004
+35	0.006	0.020	-0.011

Voltage	Test Result (ppm)@NT		
	Channel 1312	Channel 1412	Channel 1513
LV	0.011	-0.002	0.009
HV	0.016	0.010	0.007

HSDPA Mode:

Temperature(°C)	Test Result (ppm)@NV		
	Channel 1312	Channel 1412	Channel 1513
0	0.007	0.019	-0.005
+10	-0.012	0.004	-0.001
+20	0.005	-0.012	0.017
+30	-0.002	-0.008	0.010
+35	0.011	0.014	0.010

Voltage	Test Result (ppm)@NT		
	Channel 1312	Channel 1412	Channel 1513
LV	-0.003	0.011	0.009
HV	0.007	0.004	0.004

Peak-Average Ratio -FCC Part 24.232(d)/ 27.50(d)(5)

WCDMA band II

REL99 Mode:

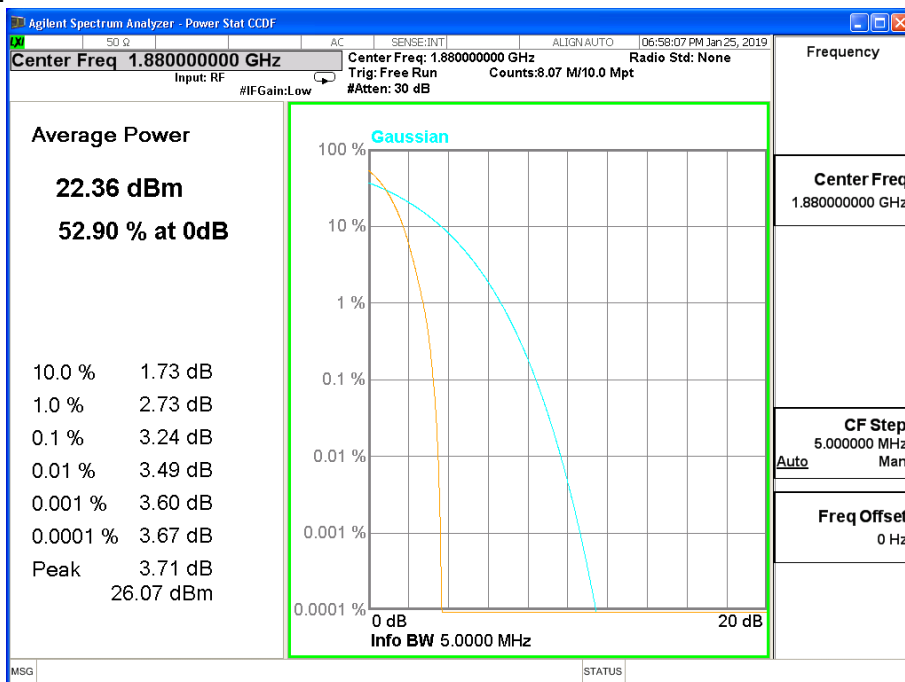

HSDPA Mode:

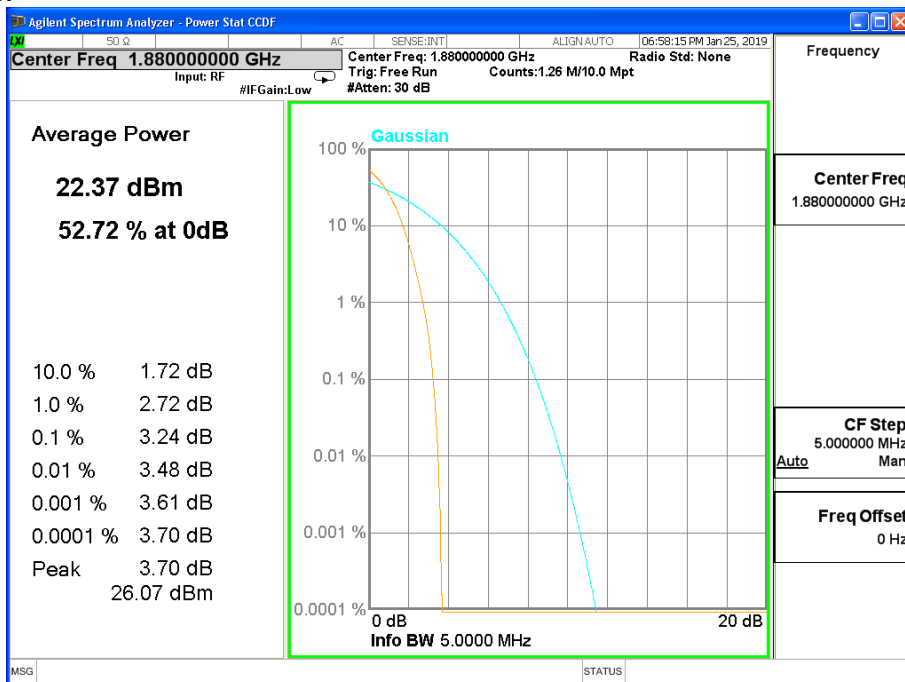

WCDMA band IV

REL99 Mode:

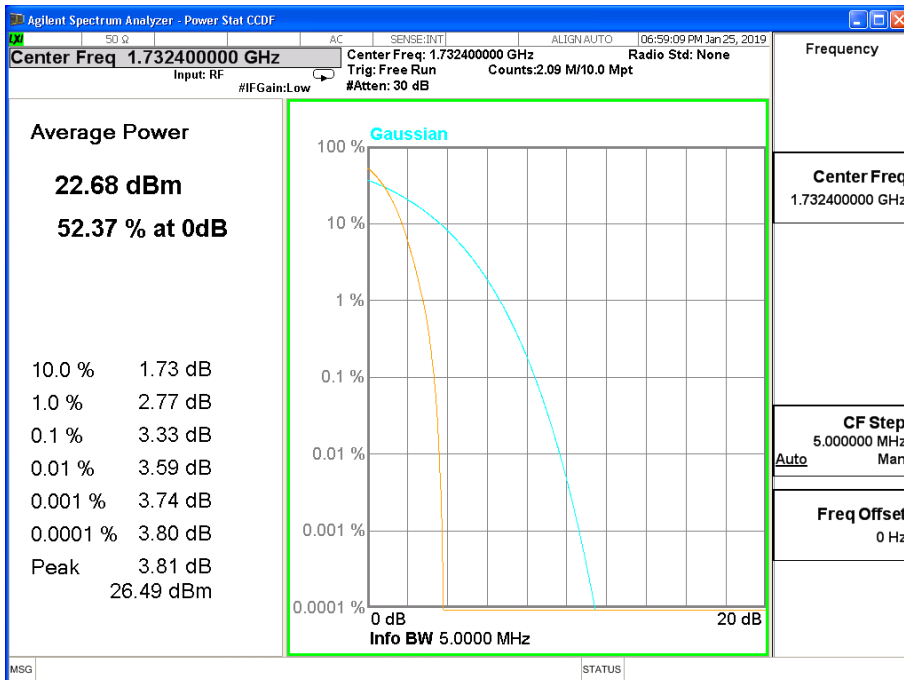

HSDPA Mode:

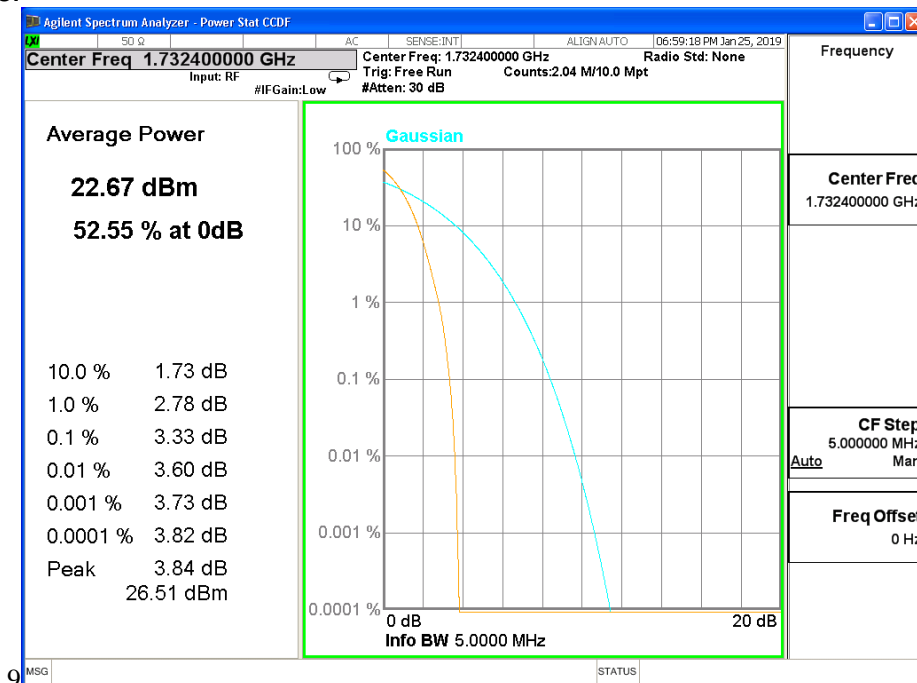

WCDMA band V

REL99 Mode:

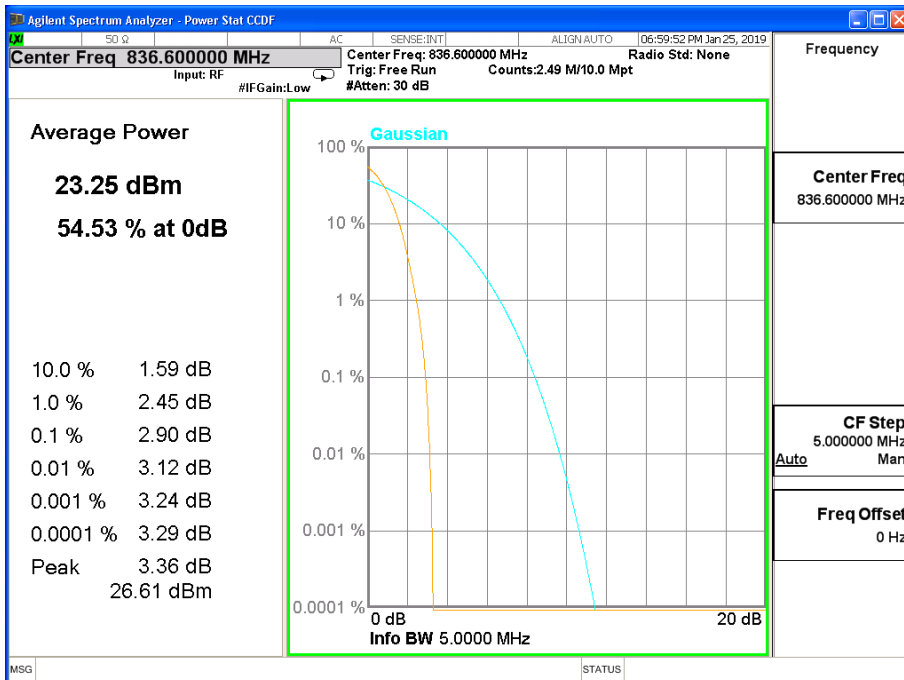

HSDPA Mode:

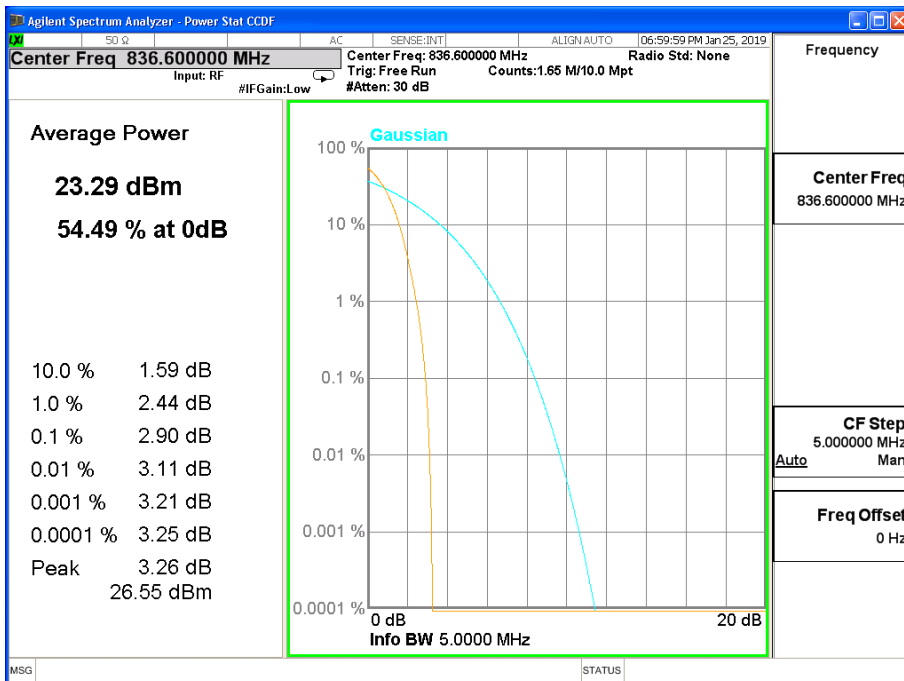

APPENDIX B – TEST DATA OF RADIATED EMISSION

WCDMA band II

Test result:

WCDMA Mode:

Channel 9662

Frequency (MHz)	Power (dBm)	Limited (dBm)	Polarization
2456.59	-49.08	-13	Vertical
2781.80	-47.68	-13	Horizontal
3725.71	-39.77	-13	Vertical
6677.35	-39.66	-13	Vertical
9958.69	-37.53	-13	Vertical
17822.24	-35.19	-13	Vertical

Channel 9800

Frequency (MHz)	Power (dBm)	Limited (dBm)	Polarization
2456.24	-49.65	-13	Vertical
2777.89	-47.99	-13	Vertical
3727.53	-40.04	-13	Vertical
6679.84	-39.94	-13	Vertical
9958.91	-37.49	-13	Vertical
17825.01	-34.19	-13	Horizontal

Channel 9938

Frequency (MHz)	Power (dBm)	Limited (dBm)	Polarization
2457.00	-49.26	-13	Vertical
2776.77	-48.51	-13	Horizontal
3730.22	-39.81	-13	Vertical
6676.80	-40.34	-13	Vertical
9962.27	-37.77	-13	Vertical
17821.28	-34.20	-13	Vertical

HSDPA/HSUPA Mode:
Channel 9662

Frequency (MHz)	Power (dBm)	Limited (dBm)	Polarization
2459.64	-49.07	-13	Vertical
2776.69	-47.77	-13	Vertical
3725.69	-40.12	-13	Vertical
6679.55	-39.43	-13	Horizontal
9959.37	-38.21	-13	Vertical
17822.45	-34.57	-13	Vertical

Channel 9800

Frequency (MHz)	Power (dBm)	Limited (dBm)	Polarization
2460.46	-49.47	-13	Vertical
2779.05	-47.23	-13	Vertical
3727.33	-39.69	-13	Vertical
6675.70	-40.84	-13	Vertical
9960.47	-37.36	-13	Vertical
17825.40	-33.93	-13	Vertical

Channel 9938

Frequency (MHz)	Power (dBm)	Limited (dBm)	Polarization
2459.56	-49.60	-13	Vertical
2777.81	-48.02	-13	Vertical
3727.60	-40.56	-13	Vertical
6675.08	-40.62	-13	Vertical
9962.54	-36.98	-13	Horizontal
17823.30	-34.21	-13	Horizontal

WCDMA band IV

We chose DIV Ant to perform the test for the worst case.

Test result:

WCDMA Mode:

Channel 1537

Frequency (MHz)	Power (dBm)	Limited (dBm)	Polarization
2457.22	-49.09	-13	Vertical
2774.91	-47.65	-13	Vertical
3728.28	-40.85	-13	Vertical
6674.06	-40.18	-13	Vertical
9960.56	-37.35	-13	Horizontal
17824.64	-34.59	-13	Vertical

Channel 1637

Frequency (MHz)	Power (dBm)	Limited (dBm)	Polarization
2459.01	-49.25	-13	Vertical
2777.07	-47.96	-13	Vertical
3728.88	-40.57	-13	Vertical
6678.77	-40.28	-13	Vertical
9960.33	-37.08	-13	Vertical
17819.81	-34.22	-13	Vertical

Channel 1738

Frequency (MHz)	Power (dBm)	Limited (dBm)	Polarization
2459.49	-49.65	-13	Vertical
2778.32	-47.37	-13	Horizontal
3730.62	-40.86	-13	Horizontal
6675.72	-40.05	-13	Vertical
9960.57	-37.15	-13	Vertical
17822.99	-33.55	-13	Vertical

HSDPA/HSUPA Mode:
Channel 1537

Frequency (MHz)	Power (dBm)	Limited (dBm)	Polarization
2457.63	-49.87	-13	Vertical
2780.24	-47.54	-13	Vertical
3724.52	-40.44	-13	Vertical
6677.03	-39.96	-13	Vertical
9958.73	-37.63	-13	Horizontal
17824.75	-34.73	-13	Vertical

Channel 1637

Frequency (MHz)	Power (dBm)	Limited (dBm)	Polarization
2457.82	-49.22	-13	Vertical
2779.40	-46.90	-13	Horizontal
3728.32	-40.83	-13	Vertical
6676.51	-40.03	-13	Vertical
9961.77	-37.19	-13	Vertical
17821.93	-34.18	-13	Vertical

Channel 1738

Frequency (MHz)	Power (dBm)	Limited (dBm)	Polarization
2462.12	-49.33	-13	Vertical
2776.72	-47.19	-13	Vertical
3726.48	-40.73	-13	Vertical
6676.58	-40.69	-13	Vertical
9961.86	-37.60	-13	Horizontal
17821.42	-34.22	-13	Vertical

WCDMA band V

We chose Main Ant to perform the test for the worst case.

Test result:

WCDMA Mode:

Channel 4357

Frequency (MHz)	Power (dBm)	Limited (dBm)	Polarization
1646.70	-52.65	-13	Vertical
1668.16	-50.86	-13	Vertical
2534.05	-43.79	-13	Vertical
2575.06	-44.34	-13	Vertical
8961.50	-39.31	-13	Vertical
9971.09	-36.52	-13	Vertical

Channel 4408

Frequency (MHz)	Power (dBm)	Limited (dBm)	Polarization
1647.41	-51.88	-13	Vertical
1666.03	-51.20	-13	Horizontal
2533.48	-44.10	-13	Horizontal
2576.98	-44.23	-13	Vertical
8961.88	-40.13	-13	Vertical
9969.82	-35.58	-13	Vertical

Channel 4458

Frequency (MHz)	Power (dBm)	Limited (dBm)	Polarization
1648.26	-52.58	-13	Vertical
1663.87	-51.72	-13	Horizontal
2534.61	-43.53	-13	Vertical
2574.42	-43.44	-13	Vertical
8964.52	-39.77	-13	Vertical
9973.35	-36.71	-13	Vertical

HSDPA/HSUPA Mode:
Channel 4357

Frequency (MHz)	Power (dBm)	Limited (dBm)	Polarization
1650.54	-52.32	-13	Vertical
1666.74	-51.04	-13	Vertical
2536.01	-44.30	-13	Vertical
2576.74	-43.47	-13	Horizontal
8966.61	-38.98	-13	Vertical
9969.69	-35.46	-13	Vertical

Channel 4408

Frequency (MHz)	Power (dBm)	Limited (dBm)	Polarization
1648.67	-52.37	-13	Vertical
1667.23	-51.30	-13	Vertical
2534.97	-44.17	-13	Horizontal
2577.18	-44.25	-13	Vertical
8964.65	-39.77	-13	Vertical
9973.17	-35.79	-13	Vertical

Channel 4458

Frequency (MHz)	Power (dBm)	Limited (dBm)	Polarization
1647.63	-52.20	-13	Vertical
1667.69	-51.02	-13	Vertical
2535.75	-44.30	-13	Vertical
2575.13	-44.57	-13	Vertical
8963.08	-40.31	-13	Vertical
9968.13	-36.77	-13	Vertical

---End of Test Report---