



TEST REPORT

No.25B01N000490-003-Audio

For

Sun Cupid Technology (HK) Ltd.

LTE Smart phone

Model Name: N6504L、N21、NUU N21

With

Hardware Version: V15

Software Version: N6504L-AM-UGO-MV03203-01.g

FCC ID: 2ADINN6504L

Issued Date: 2025-05-27

Designation Number: CN1210

Note:

The test results in this test report relate only to the devices specified in this report. This report shall not be reproduced except in full without the written approval of SAICT.

Test Laboratory:

SAICT, Shenzhen Academy of Information and Communications Technology

Building G, Shenzhen International Innovation Center, No.1006 Shennan Road, Futian District, Shenzhen,

Guangdong, P. R. China 518000.

Tel:+86(0)755-33322000, Fax:+86(0)755-33322001

Email: yewu@caict.ac.cn. www.saict.ac.cn



Revision Version

Report Number	Revision	Description	Issued Date
25B01N000490-003-Audio	Rev.0	1st edition	2025-05-27

NOTE: The previous version of the report is invalid for this revised edition.

CONTENTS

1. Summary of Test Report	5
1.1. Test Items	5
1.2. Test Standards	5
1.3. Test Result.....	5
1.4. Testing Location	5
1.5. Project Data.....	5
1.6. Signature	5
2. Client Information	6
2.1. Applicant Information.....	6
2.2. Manufacturer Information	6
3. Equipment Under Test (EUT) and Ancillary Equipment (AE)	7
3.1. About EUT	7
3.2. Internal Identification of EUT	7
3.3. Internal Identification of AE Used During The Test.....	7
3.4. General Description.....	7
4. Reference Documents for Testing	8
5. Test Results	9
5.1. Testing Environment	9
5.2. Summary of Test Results	9
5.3. Statement	9
6. Test Equipments Utilized	10
6.1. Test Equipments	10
6.2. GSM and WCDMA Test Connection Diagrams	10
6.3. LTE Test Connection Diagrams	11
6.4. WiFi Test Connection Diagrams	12
ANNEX A Test Method and requirements	13
A.1 RECEIVE VOLUME CONTROL PERFORMANCE	13
A.2 RECEIVE DISTORTION AND NOISE PERFORMANCE.....	14
A.3 RECEIVE ACOUSTIC FREQUENCY RESPONSE PERFORMANCE.....	15
ANNEX B Detailed Test Results	17



B.1. GSM TEST RESULTS.....	17
B.2. WCDMA TEST RESULTS	18
B.3. LTE TEST RESULTS	20
B.4. WiFi TEST RESULTS.....	27
ANNEX C Frequency Response Plots	30
C.1. GSM FREQUENCY RESPONSE PLOTS	30
C.2. WCDMA FREQUENCY RESPONSE PLOTS.....	32
C.3. LTE FREQUENCY RESPONSE PLOTS	38
C.4. WiFi FREQUENCY RESPONSE PLOTS	60
ANNEX D EUT photograph	70
ANNEX E Test Setup Diagrams	71

1. Summary of Test Report

1.1. Test Items

Description	LTE Smart phone
Model Name	N6504L、N21、NUU N21
Applicant's name	Sun Cupid Technology (HK) Ltd.
Manufacturer's Name	Sun Cupid Technology (HK) Ltd.

1.2. Test Standards

ANSI C63.19	2019
ANSI/TIA-5050	2018

1.3. Test Result

All test items are passed. Please refer to "5.2 Summary of Test Results" for detail.

1.4. Testing Location

Address: Building G, Shenzhen International Innovation Center, No.1006 Shennan Road, Futian District, Shenzhen, Guangdong, P. R. China518000

1.5. Project Data

Project Leader	Liang Shuzhen
Testing Start Date:	2025-03-18
Testing End Date:	2025-05-06

1.6. Signature



Li Yuhui
(Prepared this test report)

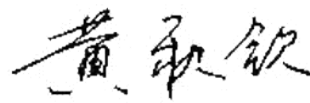

Huang Qiuqin
(Reviewed this test report)

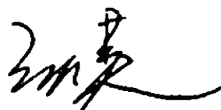

Zhang Hao
(Approved this test report)



2. Client Information

2.1. Applicant Information

Company Name: Sun Cupid Technology (HK) Ltd.
Address/Post: 16/F,CEO Tower,77 Wing Hong Street,Cheung Sha Wan,Kowloon,Hong Kong.
Contact: Danny Sit
Email: danny.sit@suncupid.com
Telephone: /
Fax: /

2.2. Manufacturer Information

Company Name: Sun Cupid Technology (HK) Ltd.
Address/Post: 16/F,CEO Tower,77 Wing Hong Street,Cheung Sha Wan,Kowloon,Hong Kong.
Contact: Danny Sit
Email: /
Telephone: /
Fax: /

3. Equipment Under Test (EUT) and Ancillary Equipment (AE)

3.1. About EUT

Description	LTE Smart phone
Model Name	N6504L、N21、NUU N21
Brand Name	NUU
Frequency Bands:	GSM 850/1900, WCDMA Band II/IV/V, LTE Band 2/4/5/12/13/17/25/26/41/66/71, Bluetooth WLAN 2.4GHz/UNII-1/UNII-2A/UNII-2C/UNII-3
Condition of EUT as received	No abnormality in appearance

Note: Photographs of EUT are shown in ANNEX D of this test report. Components list, please refer to documents of the manufacturer; it is also included in the original test record of Shenzhen Academy of Information and Communications Technology.

3.2. Internal Identification of EUT

EUT ID*	SN or IMEI	HW Version	SW Version	Sample Arrival Date
UT02aa	355242860002616	V15	N6504L-AM-UGO- MV03203-01.g	2025-03-06

*EUT ID: is used to identify the test sample in the lab internally.

3.3. Internal Identification of AE Used During The Test

AE:

AEID*	/
Description	/
Type	/
Manufacturer	/

*AE ID: is used to identify the test sample in the lab internally.

3.4. General Description

Equipment undertest (EUT) is a LTE Smart phone with integrated antenna.
Manual and specifications of the EUT were provided to fulfil the test.
Samples undergoing test were selected by the Client.



4. Reference Documents for Testing

The following documents listed in this section are referred for testing.

Reference	Title	Version
ANSI C63.19	American National Standard Methods of Measurement of Compatibility between Wireless Communications Devices and Hearing Aids Telecommunications	2019
ANSI/TIA-5050	Communications Products Receive Volume Control Requirements for Wireless (Mobile) Devices	2018
KDB 285076 D05v01	HAC COMPLIANCE UNDER WAIVER DA 23-914	2023



5. Test Results

Abbreviations used in this clause:

- P** Passed
- F** Failed
- NA** not applicable
- NM** not measured

5.1. Testing Environment

- Normal Temperature: 15-35°C
- Relative Humidity: 20-75%
- Local Bottom noise: 12.5dB

5.2. Summary of Test Results

See **ANNEX B** for detail

Summary of Test Results	VERDICT			
	NA	P	F	NM
Receive Volume Control Performance		P		
Receive Distortion and Noise Performance		P		
Receive Acoustic Frequency Response Performance		P		

The lowest conversational gain is 6.33dB with a hearing aid, and 7.73dB without a hearing-aid.

5.3. Statement

Since the information of samples in this report is provided by the client, the laboratory is not responsible for the authenticity of sample information.

This report takes measured values as criterion of test conclusion. The test conclusion meets the limit requirements.

6. Test Equipments Utilized

6.1. Test Equipments

Hardware			Acoustics Lab		
No.	Name	Type	SN	Manufacturer	Cal.Due Date
1	Measurement Frontend	lebCORE	77000455	HEAD acoustics	2026-07-23
2	Artificial Head	HMS II.3	12306254	HEAD acoustics	2025-05-18
3	Anechoic Chamber	5.10m×4.10m×2.50m	20170802	Landtop	2027-08-04
4	Universal Radio Communication Tester	CMW500	152499	R&S	2025-07-11

Software	
Name	Version
ACQUA	V6.0.200
ACQUA	V6.1.100

6.2. GSM and WCDMA Test Connection Diagrams

Test signal connection:

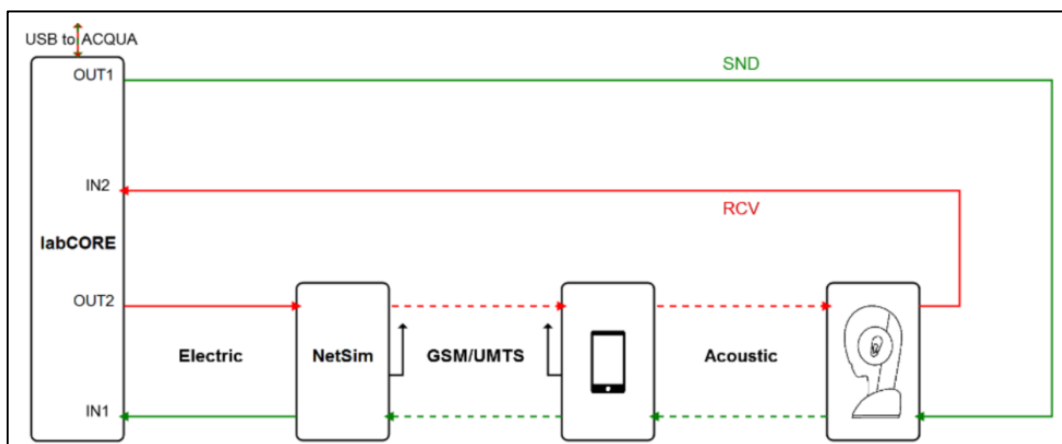

Hardware Configuration connection:

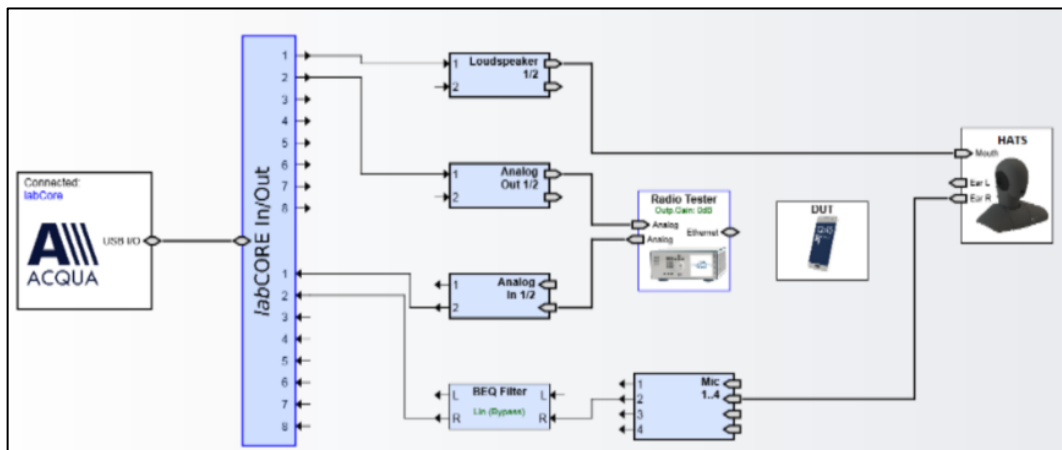

6.3. LTE Test Connection Diagrams

Test signal connection:

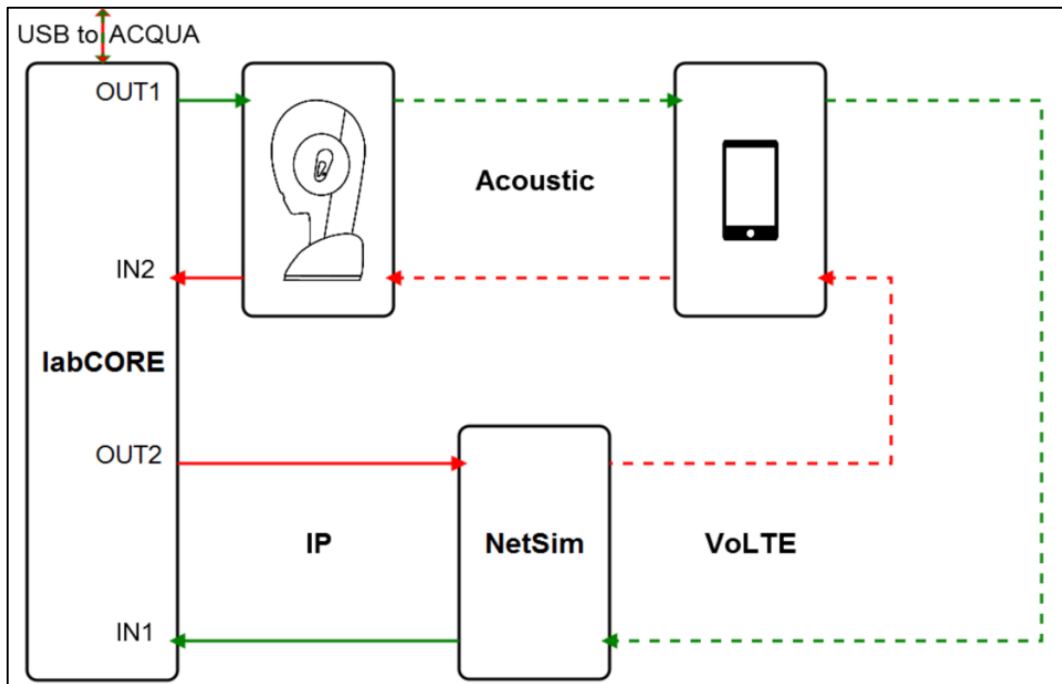

Hardware Configuration connection:

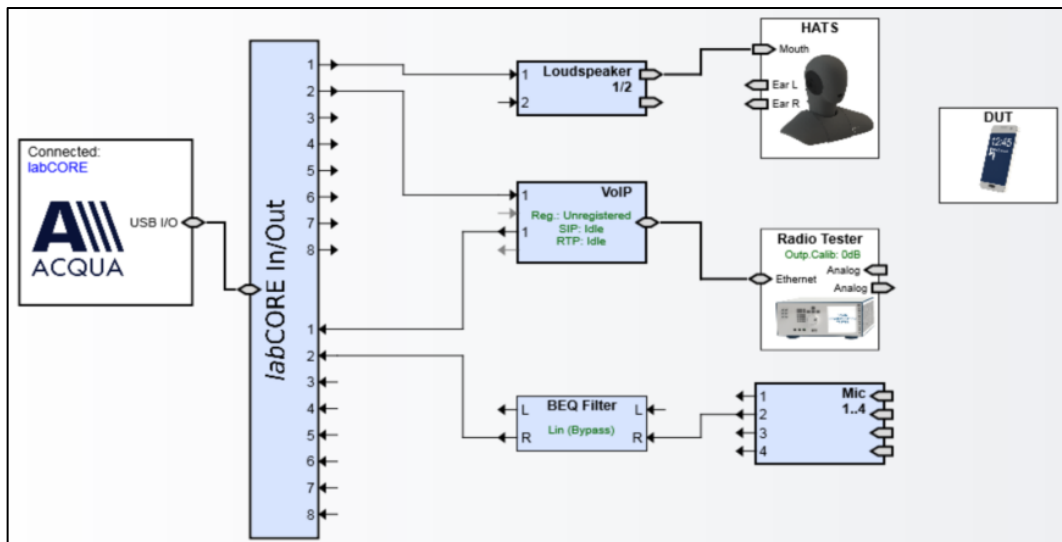

6.4. WiFi Test Connection Diagrams

Test signal connection:

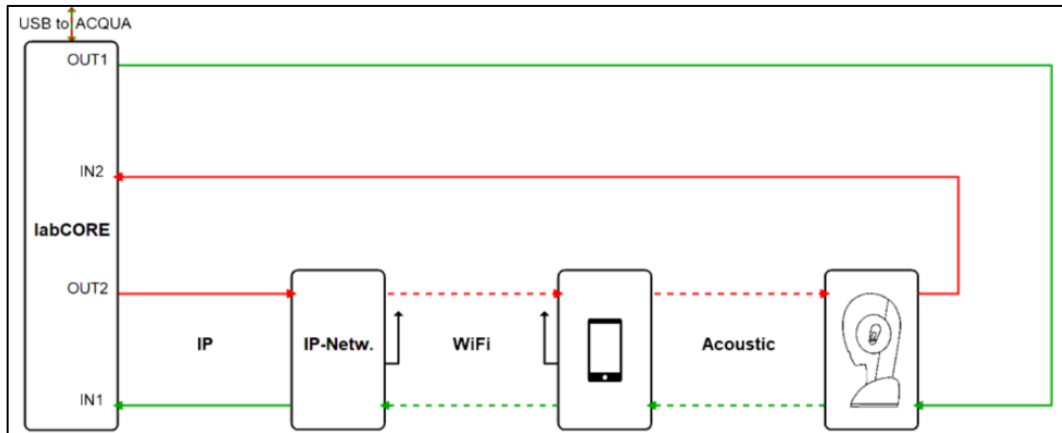

Hardware Configuration connection:

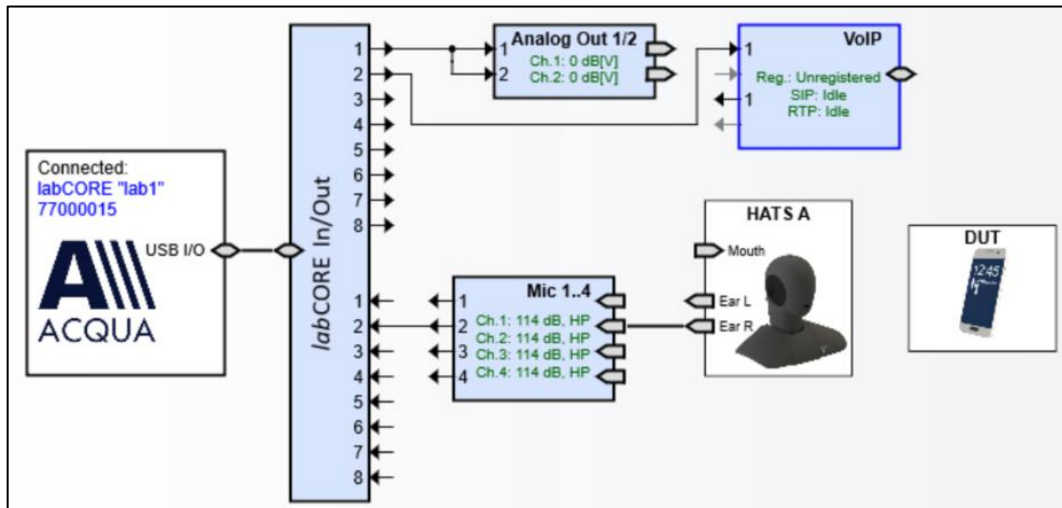

ANNEX A Test Method and requirements

A.1 Receive Volume Control Performance

Test Method:

1. Configure the DUT with a mounting force of 8N and test equipment in an active call state with the applicable codec for the transmission mode under test.
2. Set the DUT volume control to the maximum setting.
3. Apply the real speech test signal at a level of -20 dBm₀ at the RETP and measure the acoustic output at the Drum Reference Point (DRP) over one complete sequence of the test signal.
4. Over the applicable frequency band, determine the ASL in dBSPL for the resulting sound pressure level in accordance with Method B of ITU-T Recommendation P.56:
 - a. Narrowband 100 Hz through 4000 Hz.
 - b. Wideband 100 Hz through 7720 Hz.
5. Calculate the Conversational Gain by subtracting 70 dB from the measured dBSPL
[Conversational Gain=(Measured dBSPL Level -70 dBSPL) dB]
6. Repeat steps 2-5 with a mounting force of 2N.

Test requirement:

According to KDB 285076 D05v01, only CMRS narrowband and CMRS wideband voice codecs are required to comply with the volume control requirements of the TIA 5050-2018 Volume Control Standard as amended as follows:

1. For the 2N mounting force test, one narrowband and one wideband voice codec embedded with the handset must pass with at least one volume control setting with a conversational gain of ≥ 6 dB for all voice services, bands of operation and air interfaces over which it operates using one codec bit rate of the applicant's choosing.
2. For the 8N mounting force test, one narrowband and one wideband voice codec embedded with the handset must pass with at least one volume control setting with a conversational gain of ≥ 6 dB for all voice services, bands of operation and air interfaces over which they operate but is not required to meet or exceed the full 18 dB of conversational gain specified in section 5.1.1 of the TIA 5050 Volume Control Standard using one codec bit rate of the applicant's choosing.

A.2 Receive Distortion and Noise Performance

Test Method:

1. Configure the DUT with a mounting force of 8N and test equipment in an active call state with the applicable codec for the transmission mode under test with the volume control at the setting determined in A.1.
2. Receive distortion and noise is measured using the PN-SDNR procedure.
3. To ensure DUT activation, apply the real speech test signal at a level of -20 dBm₀ followed immediately by the initial 1/3 octave center frequency PN test signal in TIA 5050 Table A.1 based on the narrowband or wideband operating mode. Measure the acoustic output at the DRP over the complete sequence of the PN test signal.
4. Translate the measurement made at the DRP to the FF using the translation data in TIA 5050 Annex B.
5. Calculate the acoustic output unweighted total signal power of the stimulus measurement band as described in TIA 5050 A.2.
6. Calculate the notched A-weighting distortion and noise components as described in A.3.
7. Calculate the ratio of the signal power to the total A-weighted distortion and noise power using Eq TIA 5050 A-1.
8. Repeat for each of the remaining 1/3 octave center frequencies in TIA 5050 Table A.1 based on the narrowband or wideband operating mode.
9. Repeat steps 2-8 with a mounting force of 2N.

Test requirement:

With a mounting force of 8N and 2N, the ratio of the stimulus signal power to the 100 Hz to 8000 Hz total A-weighted distortion and noise power shall be ≥ 20 dB when tested over the range of 1/3 octave band center frequencies:

- a. Narrowband transmission mode: Each 1/3 octave band center frequency from 400 Hz to 3150 Hz
- b. Wideband transmission mode: Each 1/3 octave band center frequency from 250 Hz to 5000 Hz.

A.3 Receive Acoustic Frequency Response Performance

Test Method:

1. Configure the DUT with a mounting force of 8N and test equipment in an active call state with the applicable codec for the transmission mode under test with the volume control at the setting determined in A.1.
2. Apply the real speech test signal with a level of -20 dBm0 at the RETP.
3. Capture the frequency spectrum at the DRP of the HATS using real-time analysis with 1/12 octave bands over the frequency range from 100 Hz to 4000 Hz for narrowband measurements, or over the frequency range from 100 Hz to 8000 Hz for wideband measurements, averaged over the entire duration of the test signal.
4. Transform the DRP frequency spectrum measurement to the FF or DF (see TIA 5050 Annex B).
5. Divide the 1/12 octave measurement data by the 1/12 octave frequency spectrum of the test signal at the RETP and present the measurement in terms of dB(Pa/V).
6. Apply the applicable frequency response limits to determine compliance.
7. Repeat with a mounting force of 2N.

Test requirement:

For the volume control settings determined in B.1 with a mounting force of 8N and 2N, the receive frequency response shall be measured at the DRP in 1/12 octave bands. After translation to the FF or DF, it shall fall between the applicable upper and lower limits.

- a. Narrowband: The 1/12 octave band frequency response after translation to the FF or DF shall fall between the upper and lower limits given in Table B.3-1 and shown in Figure 1

Table A.3-1 – Narrowband Receive Frequency Response Limits

Lower Limit Frequency (Hz)	Lower Limit (dB)	Upper Limit Frequency (Hz)	Upper Limit (dB)
300	-6	100	+6
3400	-6	4000	+6

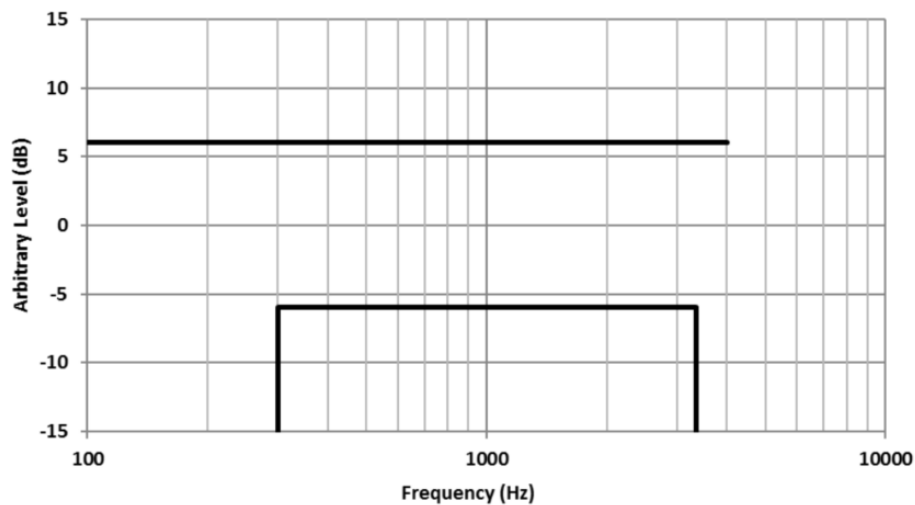

Figure A.3-1 – Narrowband Receive Frequency Response Limits

- b. Wideband: The 1/12 octave band frequency response after translation to the FF or DF shall fall between the upper and lower limits given in Table B.3-2 and shown in Figure 2.

Table A.3-2 – Wideband Receive Frequency Response Limits

Lower Limit Frequency (Hz)	Lower Limit (dB)	Upper Limit Frequency (Hz)	Upper Limit (dB)
300	-10	100	+6
300	-6	1000	+6
5000	-6	2000	+8
6300	-12	8000	+8

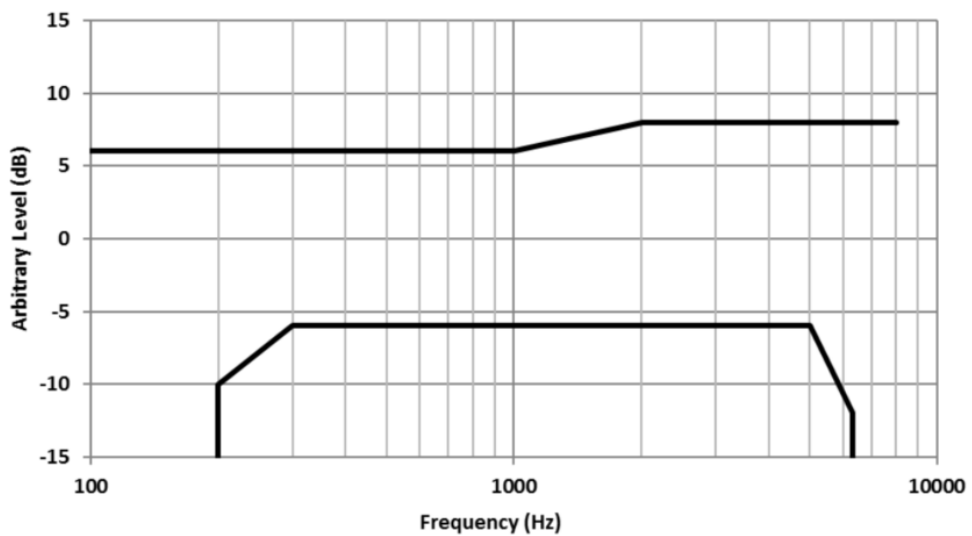

Figure A.3-2 – Wideband Receive Frequency Response Limits



ANNEX B Detailed Test Results

B.1. GSM Test Results

< EUT Supported Codec >

GSM	AMR-NB Bit Rate
	4.75 Kbps
	5.15 Kbps
	5.90 Kbps
	6.60 Kbps
	7.40 Kbps
	7.95 Kbps
	10.20 Kbps
	12.20 Kbps

< Summary Tests Results >

GSM Band	Channel	Volume Level	Codec	Voice Bandwidth	2N/8N	Receive Volume Control [dBSPL]	Conversational Gain [dB]	Minimum Receive Distortion		Receive Acoustic Frequency Response
								[Hz]	[dB]	
GSM850	162	Max-1	AMR	NB	2N	78.24	8.24	3150	21.78	Pass
GSM850	162	Max-1	AMR	NB	8N	80.30	10.30	3150	21.64	Pass
GSM1900	600	Max-1	AMR	NB	2N	77.57	7.57	3150	21.63	Pass
GSM1900	600	Max-1	AMR	NB	8N	80.04	10.04	3150	21.78	Pass

Please refer to Annex C.1 for the Frequency Response.



B.2. WCDMA Test Results

< EUT Supported Codec >

WCDMA	AMR-NB Bit Rate	AMR-WB Bit Rate
	4.75 Kbps	6.60 Kbps
	5.15 Kbps	8.85 Kbps
	5.90 Kbps	12.65 Kbps
	6.60 Kbps	14.25 Kbps
	7.40 Kbps	15.85 Kbps
	7.95 Kbps	18.25 Kbps
	10.20 Kbps	19.85 Kbps
	12.20 Kbps	23.05 Kbps
	/	23.85 Kbps

< Summary Tests Results >

WCDMA Band	Channel	Volune Level	Codec	Voice Bandwith	Bit Rate [kbps]	2N/8 N	Receive Volume Control [dBSPL]	Conversational Gain [dB]	Minimum Receive Distrotion		Receive Acoustic Frequency Response
									[Hz]	[dB]	
Band II	9262	Max-1	AMR	NB	12.2	2N	80.26	10.26	3150	21.94	Pass
Band II	9262	Max-1	AMR	NB	12.2	8N	82.69	12.69	3150	21.88	Pass
Band II	9262	Max-1	AMR	WB	23.85	2N	78.18	8.18	5000	20.56	Pass
Band II	9262	Max-1	AMR	WB	23.85	8N	80.92	10.92	5000	20.74	Pass
Band IV	1312	Max-1	AMR	NB	12.2	2N	80.36	10.36	3150	21.95	Pass
Band IV	1312	Max-1	AMR	NB	12.2	8N	82.76	12.76	3150	21.88	Pass
Band IV	1312	Max-1	AMR	WB	23.85	2N	78.15	8.15	5000	20.96	Pass



WCDMA Band	Channel	Volune Level	Codec	Voice Bandwith	Bit Rate [kbps]	2N/8 N	Receive Volume Control [dBSPL]	Conversational Gain [dB]	Minimum Receive Distrotion		Receive Acoustic Frequence Response
									[Hz]	[dB]	
Band IV	1312	Max-1	AMR	WB	23.85	8N	80.83	10.83	5000	20.63	Pass
Band V	4132	Max-1	AMR	NB	12.2	2N	80.14	10.14	3150	21.74	Pass
Band V	4132	Max-1	AMR	NB	12.2	8N	82.85	12.85	3150	21.89	Pass
Band V	4132	Max-1	AMR	WB	23.85	2N	77.90	7.90	5000	21.35	Pass
Band V	4132	Max-1	AMR	WB	23.85	8N	80.74	10.74	5000	21.68	Pass

Please refer to Annex C.2 for the Frequency Response.



B.3. LTE Test Results

< EUT Supported Codec >

	AMR-NB Bit Rate	AMR-WB Bit Rate	EVS-NB Bit Rate	EVS-WB Bit Rate
VoLTE	4.75 Kbps	6.60 Kbps	5.9 Kbps	5.9 Kbps
	5.15 Kbps	8.85 Kbps	7.2 Kbps	7.2 Kbps
	5.90 Kbps	12.65 Kbps	8.0 Kbps	8.0 Kbps
	6.60 Kbps	14.25 Kbps	9.6 Kbps	9.6 Kbps
	7.40 Kbps	15.85 Kbps	13.2 Kbps	13.2 Kbps
	7.95 Kbps	18.25 Kbps	/	/
	10.20 Kbps	19.85 Kbps	/	/
	12.20 Kbps	23.05 Kbps	/	/
	/	23.85 Kbps	/	/

An investigation was performed to determine the modulation, the bandwidth configuration and RB configuration to be used for testing.

For most LTE FDD bands, 20MHz BW, QPSK, 100RB, 0RB offset was used for the testing as the worst-case configuration for the handset.

For TD-LTE bands, 20MHz BW, QPSK, 100RB, 0RB offset was used for the testing as the worst-case configuration for the handset.

For LTE FDD Band 12, the available bandwidths are limited to 1.4MHz, 3MHz, 5MHz and 10MHz. 10MHz BW, QPSK, 100RB, 0RB offset was used for the testing as the worst-case configuration for the handset.

For LTE FDD Band 13/17, the available bandwidths are limited to 5MHz and 10MHz. 10MHz BW, QPSK, 100RB, 0RB offset was used for the testing as the worst-case configuration for the handset.

For LTE FDD Band 26, the available bandwidths are limited to 1.4MHz, 3MHz, 5MHz, 10MHz and 15MHz. 10MHz BW, QPSK, 100RB, 0RB offset was used for the testing as the worst-case configuration for the handset.

See below table for comparisons between different radios configurations:



< Radio Configuration Investigation >

LTE Band		Channel	Bandwidth [MHz]	Modulation	RB Size	RB Off Size	Volune Level	Codec	NB/WB	Bit Rate [kbps]	2N/8N	Minimum Distortion	
												[Hz]	[dB]
LTE FDD	Band 2	18900	20	QPSK	1	0	Max-1	AMR	WB	23.85	8N	1250	22.10
	Band 2	18900	20	QPSK	50	0	Max-1	AMR	WB	23.85	8N	1250	21.67
	Band 2	18900	20	QPSK	100	0	Max-1	AMR	WB	23.85	8N	1250	21.59
	Band 2	18900	20	16QAM	1	0	Max-1	AMR	WB	23.85	8N	1250	21.61
	Band 2	18900	15	QPSK	100	0	Max-1	AMR	WB	23.85	8N	1250	22.09
	Band 2	18900	10	QPSK	100	0	Max-1	AMR	WB	23.85	8N	1250	22.07
	Band 2	18900	5	QPSK	100	0	Max-1	AMR	WB	23.85	8N	1250	22.20
	Band 2	18900	3	QPSK	100	0	Max-1	AMR	WB	23.85	8N	1250	21.95
	Band 2	18900	1.4	QPSK	100	0	Max-1	AMR	WB	23.85	8N	1250	21.83
TD-LTE	Band 41	41140	20	QPSK	1	0	Max-1	AMR	WB	23.85	8N	2000	22.06
	Band 41	41140	20	QPSK	50	0	Max-1	AMR	WB	23.85	8N	1250	22.44
	Band 41	41140	20	QPSK	100	0	Max-1	AMR	WB	23.85	8N	1250	21.57
	Band 41	41140	20	16QAM	1	0	Max-1	AMR	WB	23.85	8N	1250	22.15
	Band 41	41140	20	64QAM	1	0	Max-1	AMR	WB	23.85	8N	1250	21.73
	Band 41	41140	10	QPSK	100	0	Max-1	AMR	WB	23.85	8N	1250	21.63
	Band 41	41140	5	QPSK	100	0	Max-1	AMR	WB	23.85	8N	1250	22.24



< LTE FDD Summary Tests Results >

LTE Band	Channel	Volune Level	Codec	Voice Bandwith	Bit Rate [kbps]	2N/8N	Receive Volume Control [dBSPL]	Conversational Gain [dB]	Minimum Distortion		Receive Acoustic Frequency Response
									[Hz]	[dB]	
Band 2	18900	Max-1	AMR	NB	12.20	2N	80.35	10.35	3150	22.10	Pass
Band 2	18900	Max-1	AMR	NB	12.20	8N	83.17	13.17	3150	22.16	Pass
Band 2	18900	Max-1	AMR	WB	23.85	2N	78.14	8.14	1250	21.58	Pass
Band 2	18900	Max-1	AMR	WB	23.85	8N	80.70	10.70	1250	21.83	Pass
Band 2	18900	Max-1	EVS	NB	13.2	2N	79.84	9.84	/	/	/
Band 2	18900	Max-1	EVS	NB	13.2	8N	83.81	13.81	/	/	/
Band 2	18900	Max-1	EVS	WB	13.2	2N	78.06	8.06	/	/	/
Band 2	18900	Max-1	EVS	WB	13.2	8N	81.72	11.72	/	/	/
Band 4	20175	Max-1	AMR	NB	12.20	2N	80.16	10.16	3150	22.10	Pass
Band 4	20175	Max-1	AMR	NB	12.20	8N	82.90	12.90	3150	21.77	Pass
Band 4	20175	Max-1	AMR	WB	23.85	2N	77.05	7.05	1250	21.85	Pass
Band 4	20175	Max-1	AMR	WB	23.85	8N	80.58	10.58	1250	22.30	Pass
Band 4	20175	Max-1	EVS	NB	13.2	2N	79.75	9.75	/	/	/
Band 4	20175	Max-1	EVS	NB	13.2	8N	83.84	13.84	/	/	/
Band 4	20175	Max-1	EVS	WB	13.2	2N	77.77	7.77	/	/	/
Band 4	20175	Max-1	EVS	WB	13.2	8N	81.71	11.71	/	/	/
Band 5	20525	Max-1	AMR	NB	12.20	2N	80.21	10.21	3150	21.47	Pass
Band 5	20525	Max-1	AMR	NB	12.20	8N	82.87	12.87	3150	21.23	Pass
Band 5	20525	Max-1	AMR	WB	23.85	2N	77.46	7.46	1250	21.32	Pass
Band 5	20525	Max-1	AMR	WB	23.85	8N	80.30	10.30	1250	21.83	Pass
Band 5	20525	Max-1	EVS	NB	13.2	2N	79.36	9.36	/	/	/
Band 5	20525	Max-1	EVS	NB	13.2	8N	83.67	13.67	/	/	/



LTE Band	Channel	Volume Level	Codec	Voice Bandwidth	Bit Rate [kbps]	2N/8N	Receive Volume Control [dBSPL]	Conversational Gain [dB]	Minimum Distortion		Receive Acoustic Frequency Response
									[Hz]	[dB]	
Band 5	20525	Max-1	EVS	WB	13.2	2N	78.17	8.17	/	/	/
Band 5	20525	Max-1	EVS	WB	13.2	8N	81.65	11.65	/	/	/
Band 12	23095	Max-1	AMR	NB	12.20	2N	79.83	9.83	3150	22.01	Pass
Band 12	23095	Max-1	AMR	NB	12.20	8N	82.82	12.82	3150	21.48	Pass
Band 12	23095	Max-1	AMR	WB	23.85	2N	77.14	7.14	1250	21.65	Pass
Band 12	23095	Max-1	AMR	WB	23.85	8N	80.40	10.40	1250	21.46	Pass
Band 12	23095	Max-1	EVS	NB	13.2	2N	80.06	10.06	/	/	/
Band 12	23095	Max-1	EVS	NB	13.2	8N	83.89	13.89	/	/	/
Band 12	23095	Max-1	EVS	WB	13.2	2N	77.68	7.68	/	/	/
Band 12	23095	Max-1	EVS	WB	13.2	8N	81.84	11.84	/	/	/
Band 13	23230	Max-1	AMR	NB	12.20	2N	80.01	10.01	3150	21.96	Pass
Band 13	23230	Max-1	AMR	NB	12.20	8N	82.76	12.76	3150	21.87	Pass
Band 13	23230	Max-1	AMR	WB	23.85	2N	77.44	7.44	1250	20.08	Pass
Band 13	23230	Max-1	AMR	WB	23.85	8N	80.62	10.62	1250	20.11	Pass
Band 13	23230	Max-1	EVS	NB	13.2	2N	79.79	9.79	/	/	/
Band 13	23230	Max-1	EVS	NB	13.2	8N	84.05	14.05	/	/	/
Band 13	23230	Max-1	EVS	WB	13.2	2N	77.80	7.80	/	/	/
Band 13	23230	Max-1	EVS	WB	13.2	8N	82.00	12.00	/	/	/
Band 17	23790	Max-1	AMR	NB	12.20	2N	78.35	8.35	3150	21.50	Pass
Band 17	23790	Max-1	AMR	NB	12.20	8N	82.87	12.87	3150	21.75	Pass
Band 17	23790	Max-1	AMR	WB	23.85	2N	77.19	7.19	1250	21.76	Pass
Band 17	23790	Max-1	AMR	WB	23.85	8N	80.22	10.22	1250	22.19	Pass
Band 17	23790	Max-1	EVS	NB	13.2	2N	80.04	10.04	/	/	/



LTE Band	Channel	Volume Level	Codec	Voice Bandwidth	Bit Rate [kbps]	2N/8N	Receive Volume Control [dBSPL]	Conversational Gain [dB]	Minimum Distortion		Receive Acoustic Frequency Response
									[Hz]	[dB]	
Band 17	23790	Max-1	EVS	NB	13.2	8N	83.88	13.88	/	/	/
Band 17	23790	Max-1	EVS	WB	13.2	2N	77.95	7.95	/	/	/
Band 17	23790	Max-1	EVS	WB	13.2	8N	82.07	12.07	/	/	/
Band 25	26365	Max-1	AMR	NB	12.20	2N	80.27	10.27	3150	22.02	Pass
Band 25	26365	Max-1	AMR	NB	12.20	8N	82.92	12.92	3150	21.33	Pass
Band 25	26365	Max-1	AMR	WB	23.85	2N	77.54	7.54	1250	22.05	Pass
Band 25	26365	Max-1	AMR	WB	23.85	8N	80.24	10.24	1250	21.59	Pass
Band 25	26365	Max-1	EVS	NB	13.2	2N	79.75	9.75	/	/	/
Band 25	26365	Max-1	EVS	NB	13.2	8N	83.88	13.88	/	/	/
Band 25	26365	Max-1	EVS	WB	13.2	2N	77.88	7.88	/	/	/
Band 25	26365	Max-1	EVS	WB	13.2	8N	81.84	11.84	/	/	/
Band 26	26865	Max-1	AMR	NB	12.20	2N	79.80	9.80	3150	21.62	Pass
Band 26	26865	Max-1	AMR	NB	12.20	8N	82.78	12.78	3150	21.97	Pass
Band 26	26865	Max-1	AMR	WB	23.85	2N	77.59	7.59	1250	21.94	Pass
Band 26	26865	Max-1	AMR	WB	23.85	8N	80.29	10.29	1250	21.05	Pass
Band 26	26865	Max-1	EVS	NB	13.2	2N	79.66	9.66	/	/	/
Band 26	26865	Max-1	EVS	NB	13.2	8N	83.75	13.75	/	/	/
Band 26	26865	Max-1	EVS	WB	13.2	2N	77.79	7.79	/	/	/
Band 26	26865	Max-1	EVS	WB	13.2	8N	81.99	11.99	/	/	/
Band 66	132322	Max-1	AMR	NB	12.20	2N	80.02	10.02	3150	21.96	Pass
Band 66	132322	Max-1	AMR	NB	12.20	8N	82.75	12.75	3150	21.92	Pass
Band 66	132322	Max-1	AMR	WB	23.85	2N	78.89	8.89	1250	22.16	Pass
Band 66	132322	Max-1	AMR	WB	23.85	8N	80.61	10.61	1250	21.93	Pass



LTE Band	Channel	Volume Level	Codec	Voice Bandwidth	Bit Rate [kbps]	2N/8N	Receive Volume Control [dBSPL]	Conversational Gain [dB]	Minimum Distortion		Receive Acoustic Frequency Response
									[Hz]	[dB]	
Band 66	132322	Max-1	EVS	NB	13.2	2N	79.80	9.80	/	/	/
Band 66	132322	Max-1	EVS	NB	13.2	8N	83.67	13.67	/	/	/
Band 66	132322	Max-1	EVS	WB	13.2	2N	77.88	7.88	/	/	/
Band 66	132322	Max-1	EVS	WB	13.2	8N	81.78	11.78	/	/	/
Band 71	133297	Max-1	AMR	NB	12.20	2N	80.19	10.19	3150	22.04	Pass
Band 71	133297	Max-1	AMR	NB	12.20	8N	83.03	13.03	3150	21.94	Pass
Band 71	133297	Max-1	AMR	WB	23.85	2N	77.96	7.96	1250	21.95	Pass
Band 71	133297	Max-1	AMR	WB	23.85	8N	80.54	10.54	1250	22.03	Pass
Band 71	133297	Max-1	EVS	NB	13.2	2N	80.10	10.10	/	/	/
Band 71	133297	Max-1	EVS	NB	13.2	8N	83.94	13.94	/	/	/
Band 71	133297	Max-1	EVS	WB	13.2	2N	77.91	7.91	/	/	/
Band 71	133297	Max-1	EVS	WB	13.2	8N	81.99	11.99	/	/	/

Please refer to Annex C.3 for the Frequency Response.



< TD-LTE Summary Tests Results >

LTE Band	Channel	Volume Level	Codec	Voice Bandwidth	Bit Rate [kbps]	2N/8N	Receive Volume Control [dBSPL]	Conversational Gain [dB]	Minimum Distortion		Receive Acoustic Frequency Response
									[Hz]	[dB]	
Band 41	40620	Max-1	AMR	NB	12.20	2N	79.99	9.99	3150	21.86	Pass
Band 41	40620	Max-1	AMR	NB	12.20	8N	83.04	13.04	3150	21.83	Pass
Band 41	40620	Max-1	AMR	WB	23.85	2N	77.84	7.84	1250	21.52	Pass
Band 41	40620	Max-1	AMR	WB	23.85	8N	80.51	10.51	1250	21.93	Pass
Band 41	40620	Max-1	EVS	NB	13.2	2N	80.05	10.05	/	/	/
Band 41	40620	Max-1	EVS	NB	13.2	8N	84.15	14.15	/	/	/
Band 41	40620	Max-1	EVS	WB	13.2	2N	78.05	8.05	/	/	/
Band 41	40620	Max-1	EVS	WB	13.2	8N	81.95	11.95	/	/	/

Please refer to Annex C.3 for the Frequency Response.



B.4. WiFi Test Results

< EUT Supported Codec >

VoWiFi (AMR Codec)	AMR-NB Bit Rate	AMR-WB Bit Rate	EVS-NB Bit Rate	EVS-WB Bit Rate
	4.75 Kbps	6.60 Kbps	5.9 Kbps	5.9 Kbps
	5.15 Kbps	8.85 Kbps	7.2 Kbps	7.2 Kbps
	5.90 Kbps	12.65 Kbps	8.0 Kbps	8.0 Kbps
	6.60 Kbps	14.25 Kbps	9.6 Kbps	9.6 Kbps
	7.40 Kbps	15.85 Kbps	13.2 Kbps	13.2 Kbps
	7.95 Kbps	18.25 Kbps	/	/
	10.20 Kbps	19.85 Kbps	/	/
	12.20 Kbps	23.05 Kbps	/	/
	/	23.85 Kbps	/	/

< Summary Tests Results >

WLAN Band	WLAN Standard	Channel	Volume Level	Codec	Voice Bandwidth	Bit Rate [kbps]	2N/8N	Receive Volume Control [dBSPL]	Conversational Gain [dB]	Minimum Distortion		Receive Acoustic Frequency Response
										[Hz]	[dB]	
2.4GHz	IEEE 802.11b	7	Max-1	AMR	NB	12.20	2N	78.20	8.20	3150	20.25	Pass
2.4GHz	IEEE 802.11b	7	Max-1	AMR	NB	12.20	8N	82.61	12.61	3150	20.44	Pass
2.4GHz	IEEE 802.11b	7	Max-1	AMR	WB	23.85	2N	76.54	6.54	1250	21.62	Pass
2.4GHz	IEEE 802.11b	7	Max-1	AMR	WB	23.85	8N	79.92	9.92	1250	21.30	Pass
2.4GHz	IEEE 802.11b	7	Max-1	EVS	NB	13.2	2N	78.50	8.50	/	/	/
2.4GHz	IEEE 802.11b	7	Max-1	EVS	NB	13.2	8N	82.48	12.48	/	/	/
2.4GHz	IEEE 802.11b	7	Max-1	EVS	WB	13.2	2N	78.02	8.02	/	/	/
2.4GHz	IEEE 802.11b	7	Max-1	EVS	WB	13.2	8N	80.42	10.42	/	/	/



WLAN Band	WLAN Standard	Channel	Volune Level	Codec	Voice Bandwith	Bit Rate [kbps]	2N/8N	Receive Volume Control [dB SPL]	Conversational Gain [dB]	Minimum Distortion		Receive Acoustic Frequency Response
										[Hz]	[dB]	
UNII-1	IEEE 802.11a	40	Max-1	AMR	NB	12.20	2N	78.40	8.40	3150	21.91	Pass
UNII-1	IEEE 802.11a	40	Max-1	AMR	NB	12.20	8N	82.14	12.14	3150	20.97	Pass
UNII-1	IEEE 802.11a	40	Max-1	AMR	WB	23.85	2N	77.10	7.10	2000	21.74	Pass
UNII-1	IEEE 802.11a	40	Max-1	AMR	WB	23.85	8N	80.42	10.42	1250	22.09	Pass
UNII-1	IEEE 802.11a	40	Max-1	EVS	NB	13.2	2N	78.53	8.53	/	/	/
UNII-1	IEEE 802.11a	40	Max-1	EVS	NB	13.2	8N	82.32	12.32	/	/	/
UNII-1	IEEE 802.11a	40	Max-1	EVS	WB	13.2	2N	76.56	6.56	/	/	/
UNII-1	IEEE 802.11a	40	Max-1	EVS	WB	13.2	8N	80.65	10.65	/	/	/
UNII-2A	IEEE 802.11a	64	Max-1	AMR	NB	12.20	2N	78.24	8.24	3150	21.89	Pass
UNII-2A	IEEE 802.11a	64	Max-1	AMR	NB	12.20	8N	82.14	12.14	3150	21.95	Pass
UNII-2A	IEEE 802.11a	64	Max-1	AMR	WB	23.85	2N	76.41	6.41	2000	22.11	Pass
UNII-2A	IEEE 802.11a	64	Max-1	AMR	WB	23.85	8N	80.16	10.16	1250	21.78	Pass
UNII-2A	IEEE 802.11a	64	Max-1	EVS	NB	13.2	2N	78.58	8.58	/	/	/
UNII-2A	IEEE 802.11a	64	Max-1	EVS	NB	13.2	8N	82.34	12.34	/	/	/
UNII-2A	IEEE 802.11a	64	Max-1	EVS	WB	13.2	2N	76.41	6.41	/	/	/
UNII-2A	IEEE 802.11a	64	Max-1	EVS	WB	13.2	8N	80.79	10.79	/	/	/
UNII-2C	IEEE 802.11a	120	Max-1	AMR	NB	12.20	2N	79.17	9.17	3150	21.18	Pass
UNII-2C	IEEE 802.11a	120	Max-1	AMR	NB	12.20	8N	82.76	12.76	3150	21.43	Pass
UNII-2C	IEEE 802.11a	120	Max-1	AMR	WB	23.85	2N	76.84	6.84	2000	21.93	Pass
UNII-2C	IEEE 802.11a	120	Max-1	AMR	WB	23.85	8N	80.93	10.93	1250	22.66	Pass
UNII-2C	IEEE 802.11a	120	Max-1	EVS	NB	13.2	2N	78.56	8.56	/	/	/
UNII-2C	IEEE 802.11a	120	Max-1	EVS	NB	13.2	8N	82.56	12.56	/	/	/
UNII-2C	IEEE 802.11a	120	Max-1	EVS	WB	13.2	2N	76.99	6.99	/	/	/



WLAN Band	WLAN Standard	Channel	Volune Level	Codec	Voice Bandwith	Bit Rate [kbps]	2N/8N	Receive Volume Control [dBSPL]	Conversational Gain [dB]	Minimum Distortion		Receive Acoustic Frequency Response
										[Hz]	[dB]	
UNII-2C	IEEE 802.11a	120	Max-1	EVS	WB	13.2	8N	80.57	10.57	/	/	/
UNII-3	IEEE 802.11a	157	Max-1	AMR	NB	12.20	2N	77.99	7.99	3150	21.91	Pass
UNII-3	IEEE 802.11a	157	Max-1	AMR	NB	12.20	8N	82.14	12.14	3150	21.33	Pass
UNII-3	IEEE 802.11a	157	Max-1	AMR	WB	23.85	2N	76.71	6.71	1250	21.76	Pass
UNII-3	IEEE 802.11a	157	Max-1	AMR	WB	23.85	8N	81.06	11.06	2000	22.17	Pass
UNII-3	IEEE 802.11a	157	Max-1	EVS	NB	13.2	2N	78.36	8.36	/	/	/
UNII-3	IEEE 802.11a	157	Max-1	EVS	NB	13.2	8N	82.49	12.49	/	/	/
UNII-3	IEEE 802.11a	157	Max-1	EVS	WB	13.2	2N	76.33	6.33	/	/	/
UNII-3	IEEE 802.11a	157	Max-1	EVS	WB	13.2	8N	80.36	10.36	/	/	/

Please refer to Annex C.4 for the Frequency Response.

The lowest conversational gain is 6.33dB with a hearing aid.

Turn off the accessibility feature - hearing aid function in the phone, and test with the same configuration.

WLAN Band	WLAN Standard	Channel	Volune Level	Codec	Voice Bandwith	Bit Rate [kbps]	2N/8N	Receive Volume Control [dBSPL]	Conversational Gain [dB]
UNII-3	IEEE 802.11a	157	Max-1	EVS	WB	13.2	2N	77.73	7.73

ANNEX C Frequency Response Plots

C.1. GSM Frequency Response Plots

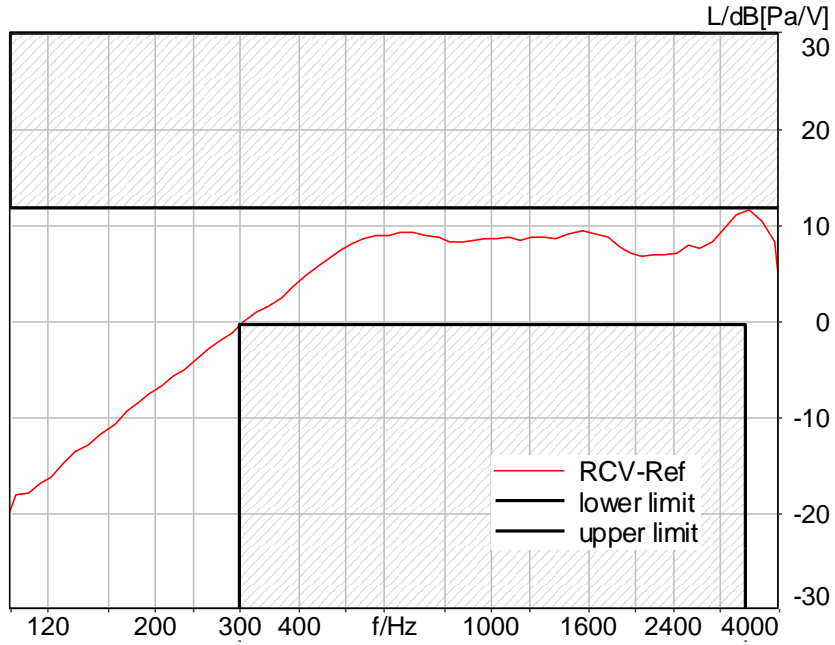

Figure C.1-1 – GSM850 2N FF Narrowband Frequency Response

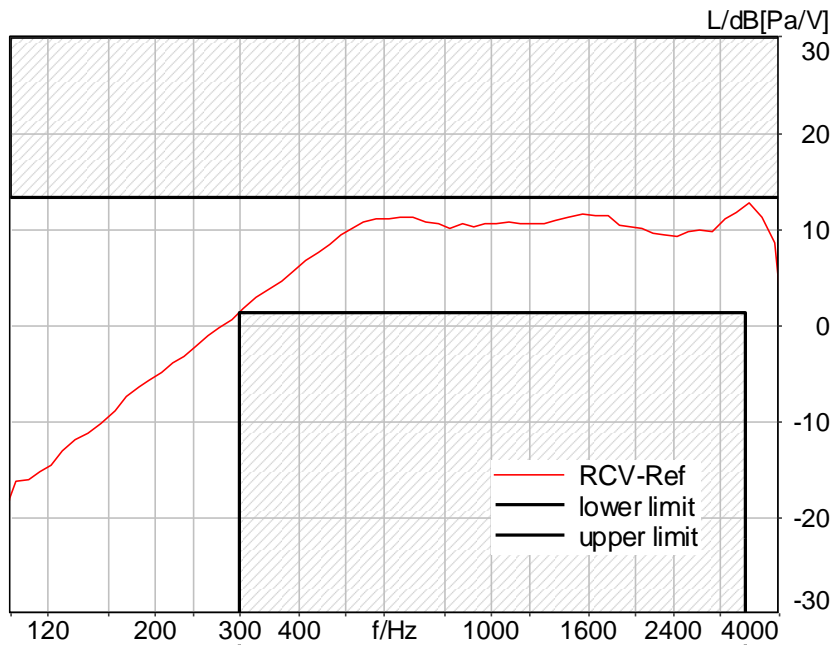

Figure C.1-2 – GSM850 8N FF Narrowband Frequency Response

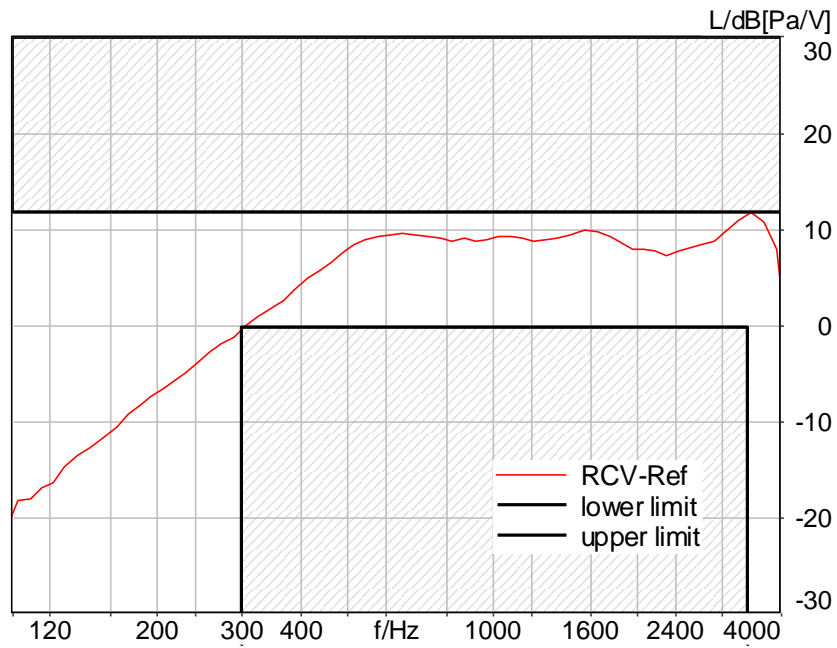

Figure C.1-3 – GSM1900 2N FF Narrowband Frequency Response

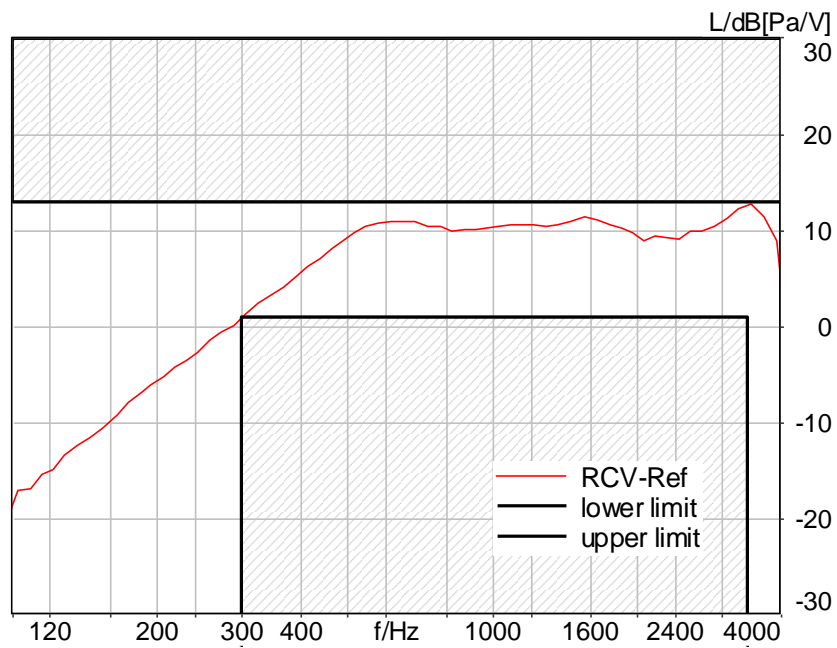

Figure C.1-4 – GSM1900 8N FF Narrowband Frequency Response

C.2. WCDMA Frequency Response Plots

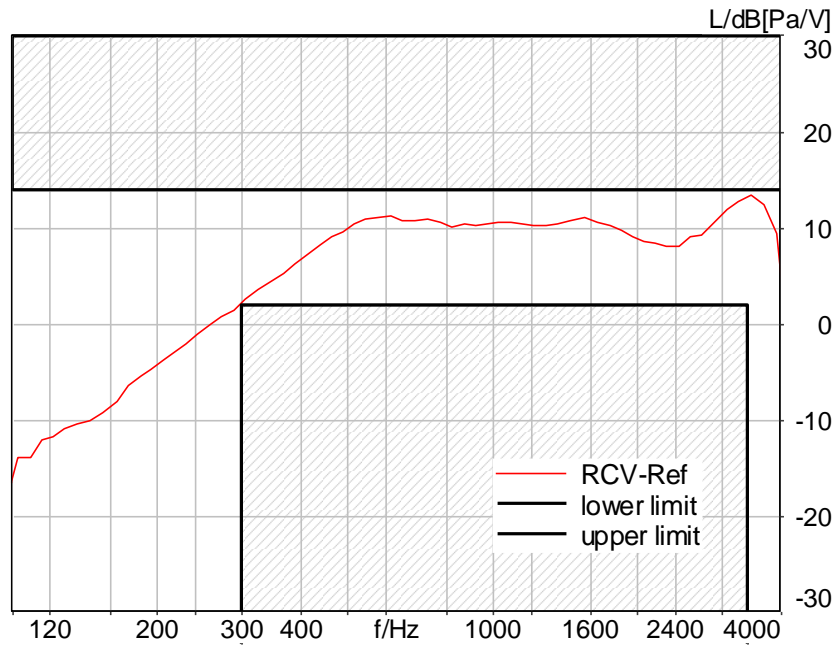

Figure C.2-1 – WCDMA Band II 2N FF Narrowband Frequency Response

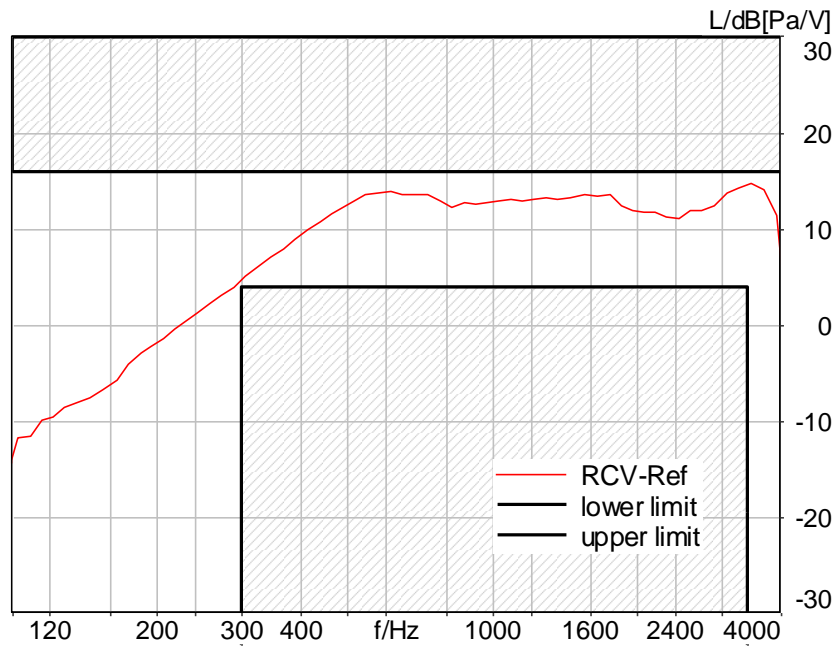

Figure C.2-2 – WCDMA Band II 8N FF Narrowband Frequency Response

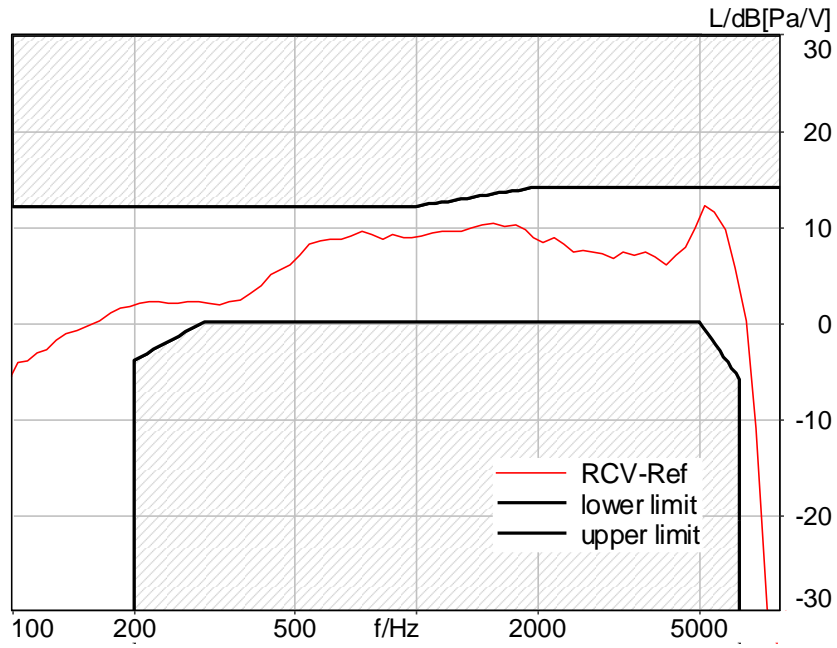

Figure C.2-3 – WCDMA Band II 2N FF Wideband Frequency Response

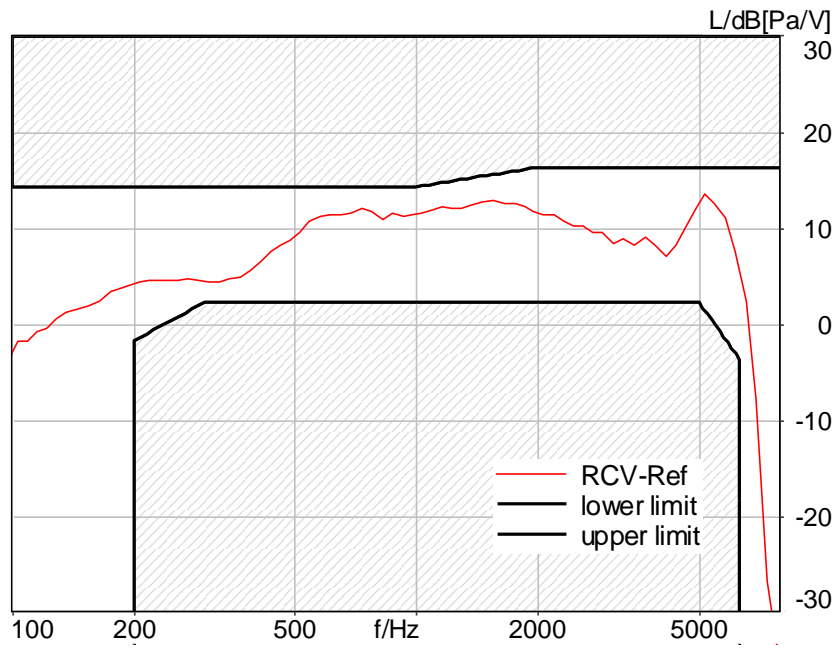

Figure C.2-4 – WCDMA Band II 8N FF Wideband Frequency Response

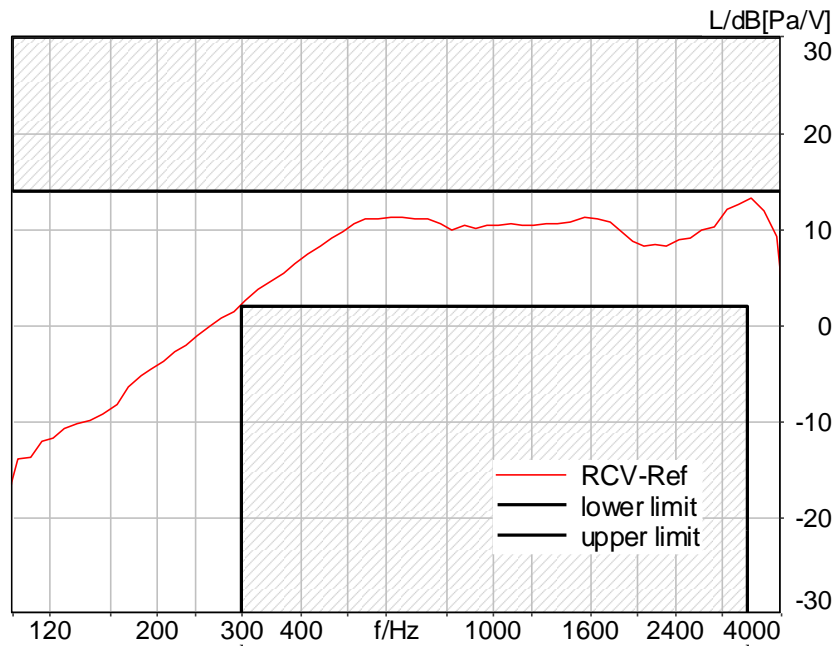

Figure C.2-5 – WCDMA Band IV 2N FF Narrowband Frequency Response

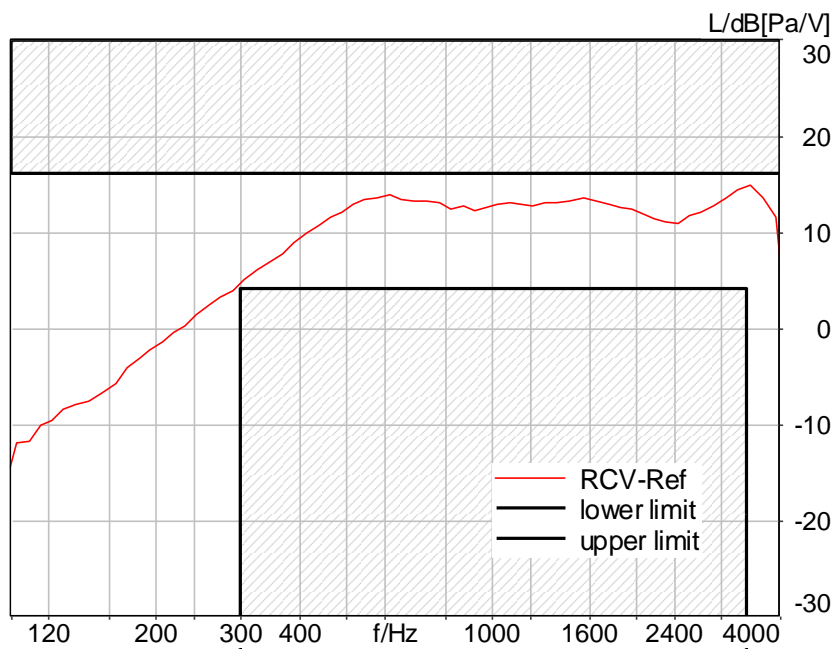

Figure C.2-6 – WCDMA Band IV 8N FF Narrowband Frequency Response

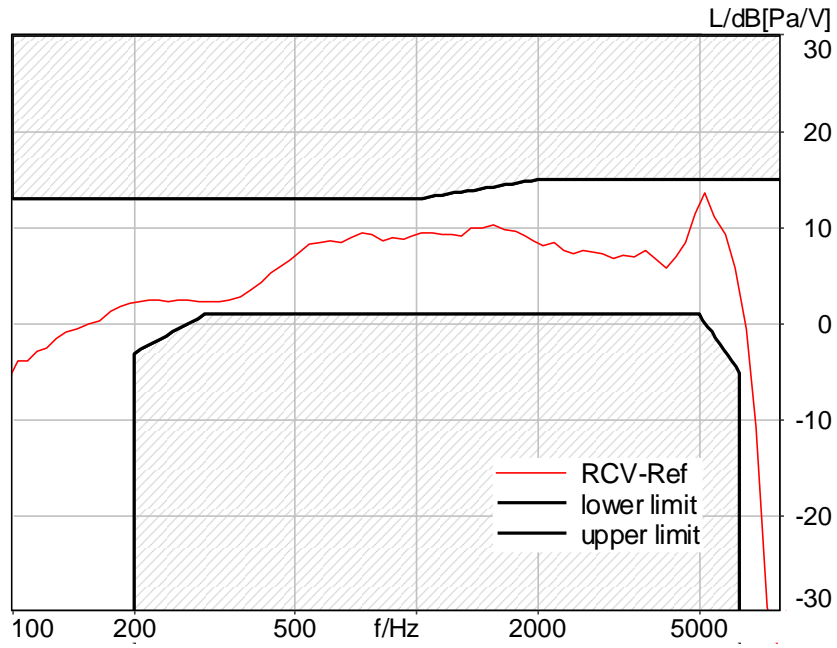

Figure C.2-7 – WCDMA Band IV 2N FF Wideband Frequency Response

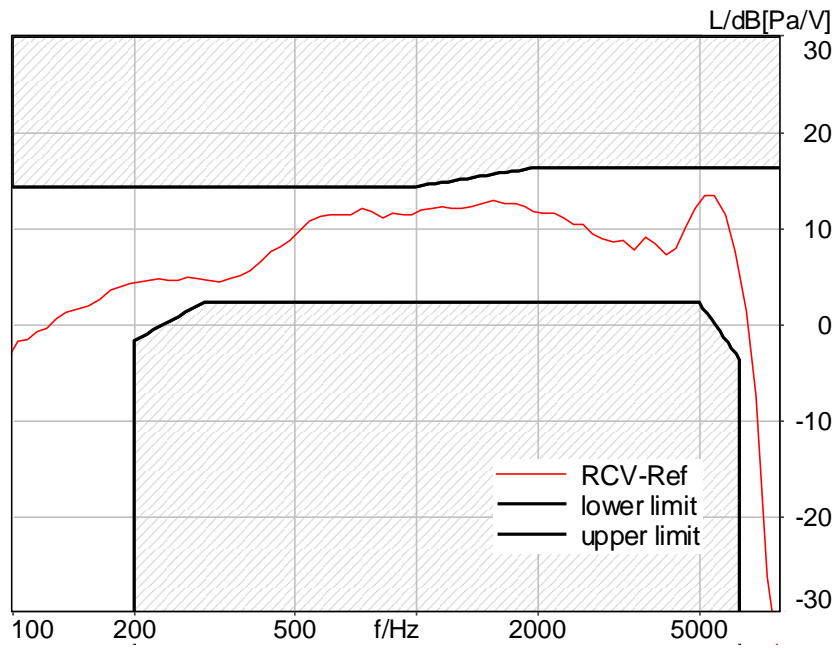

Figure C.2-8 – WCDMA Band IV 8N FF Wideband Frequency Response

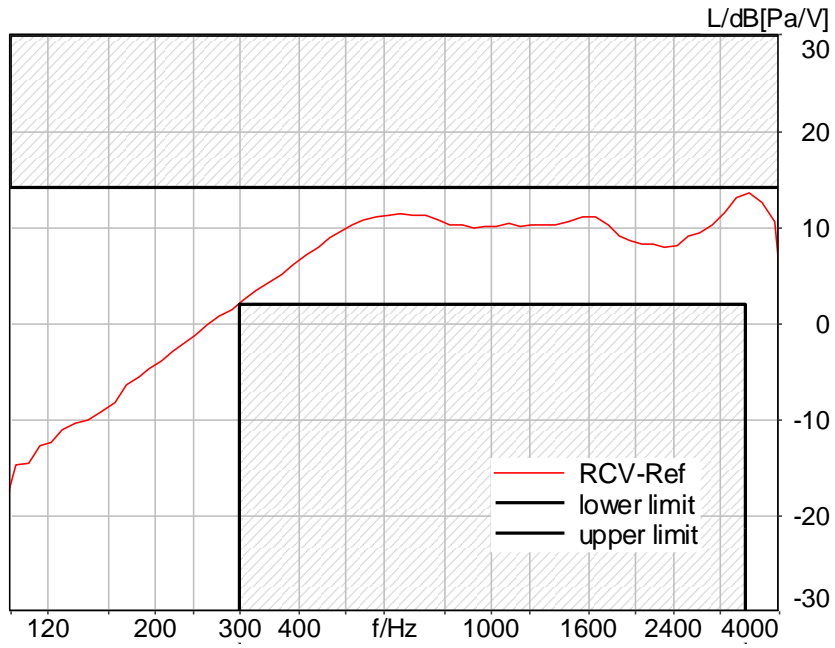

Figure C.2-9 – WCDMA Band V 2N FF Narrowband Frequency Response

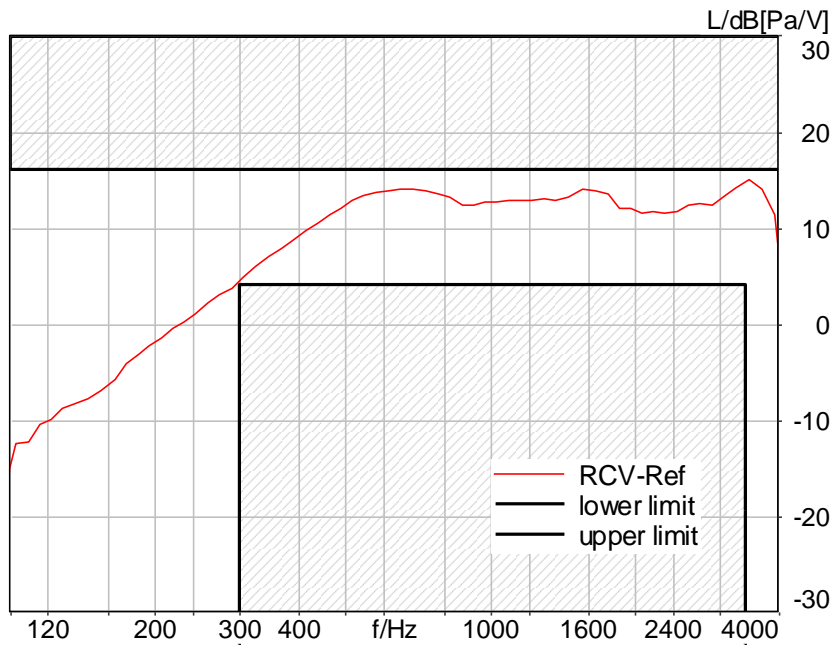

Figure C.2-10 – WCDMA Band V 8N FF Narrowband Frequency Response

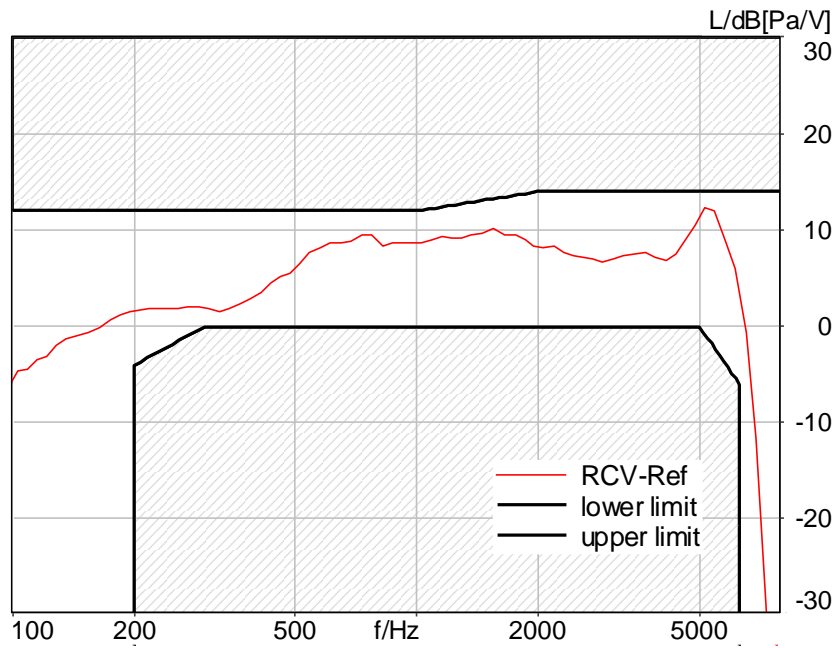

Figure C.2-11 – WCDMA Band V 2N FF Wideband Frequency Response

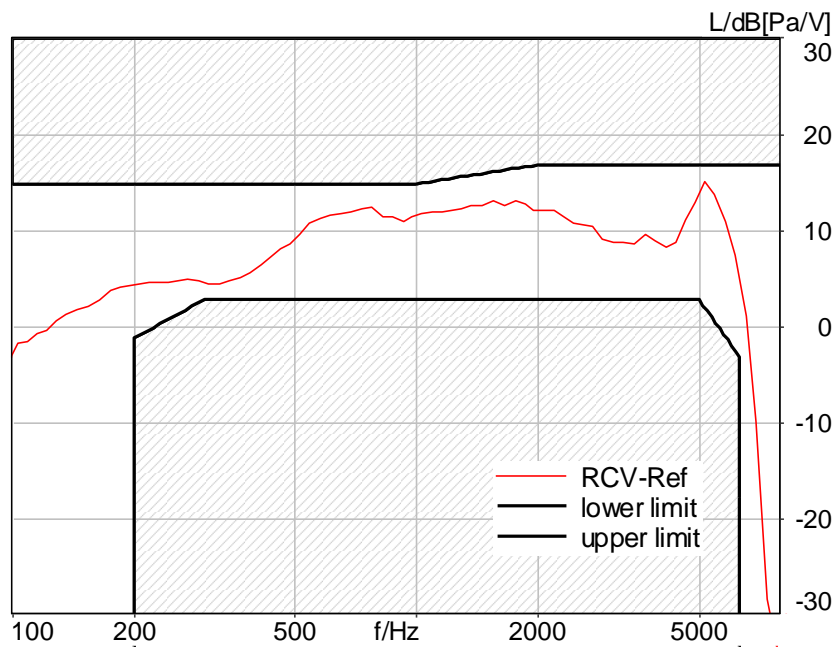

Figure C.2-12 – WCDMA Band V 8N FF Wideband Frequency Response

C.3. LTE Frequency Response Plots

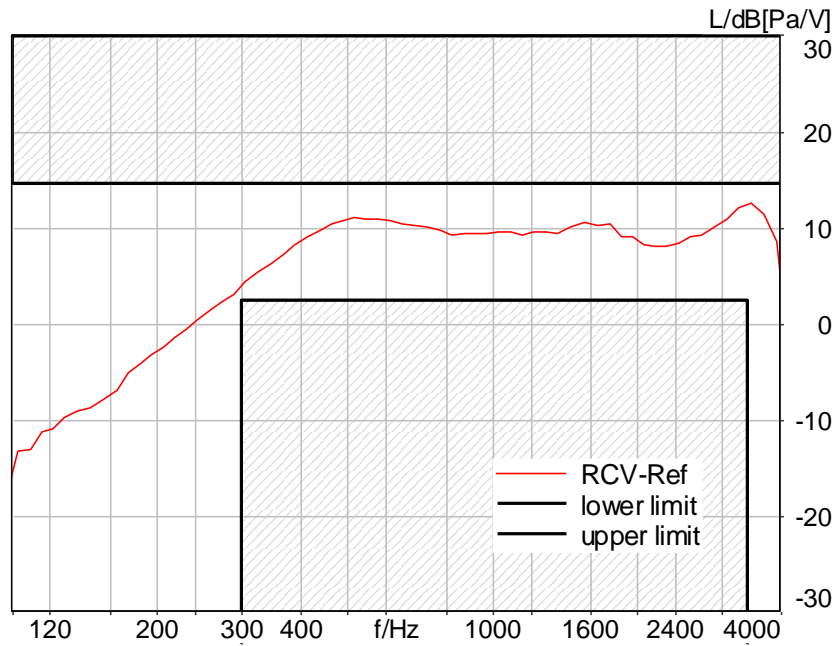

Figure C.3-1 – LTE Band 2 2N FF Narrowband Frequency Response

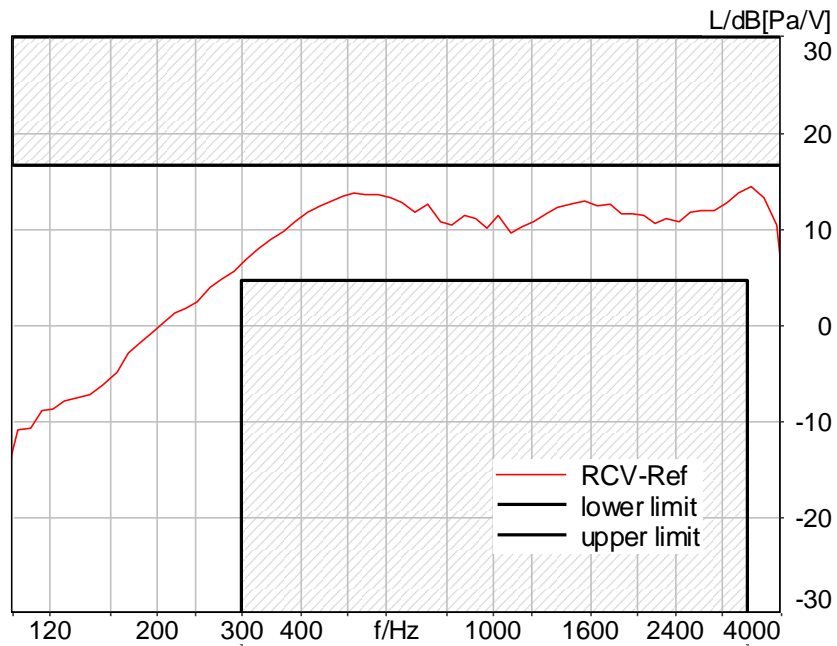

Figure C.3-2 – LTE Band 2 8N FF Narrowband Frequency Response

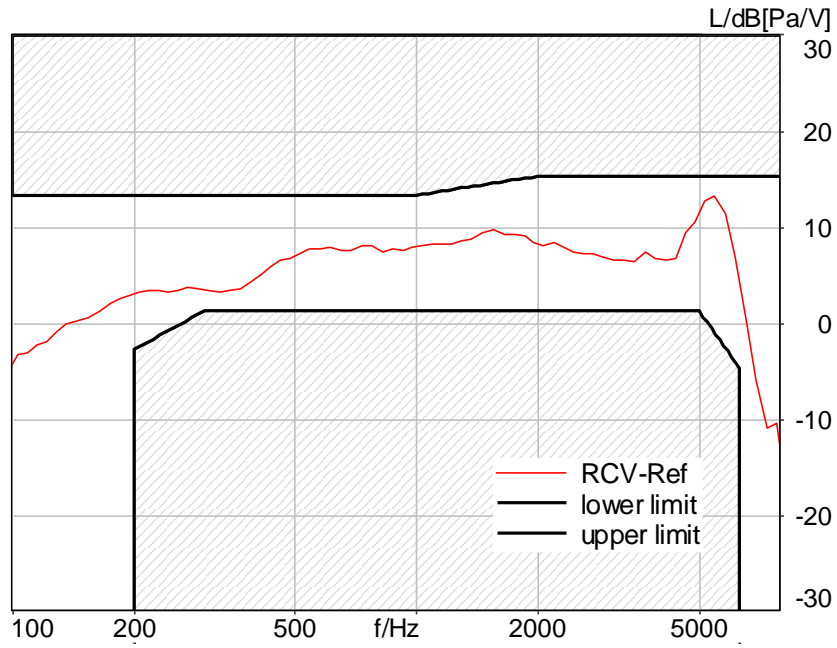

Figure C.3-3 – LTE Band 2 2N FF Wideband Frequency Response

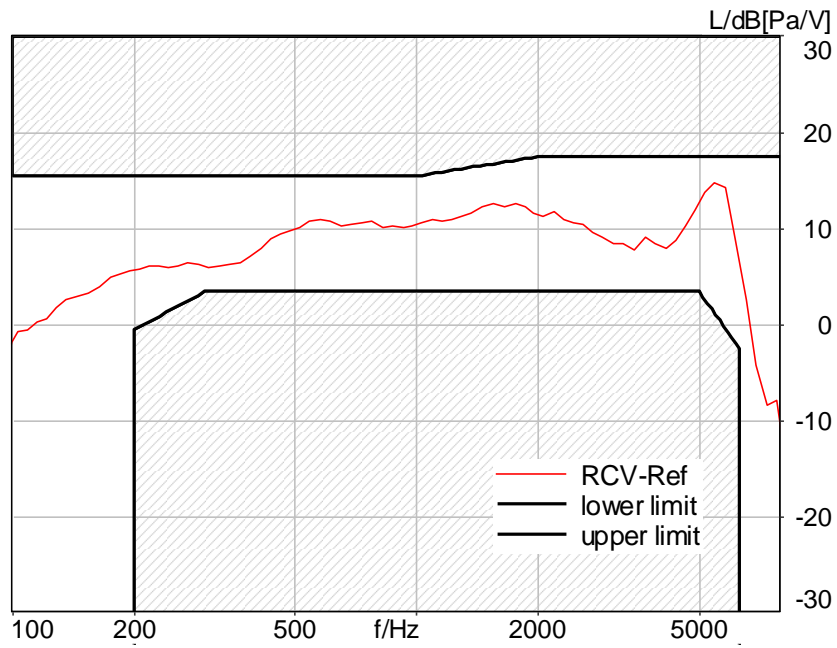

Figure C.3-4 – LTE Band 2 8N FF Wideband Frequency Response

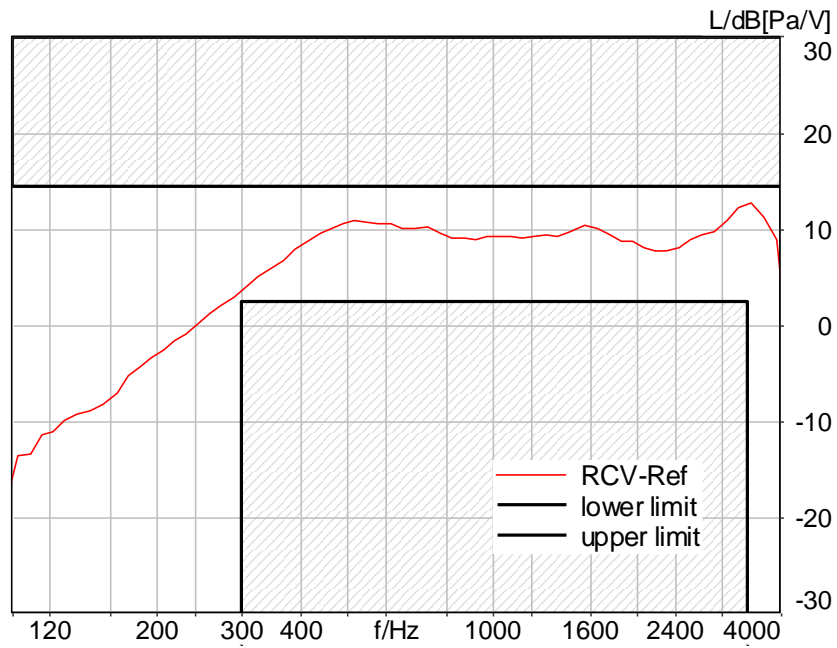

Figure C.3-5 – LTE Band 4 2N FF Narrowband Frequency Response

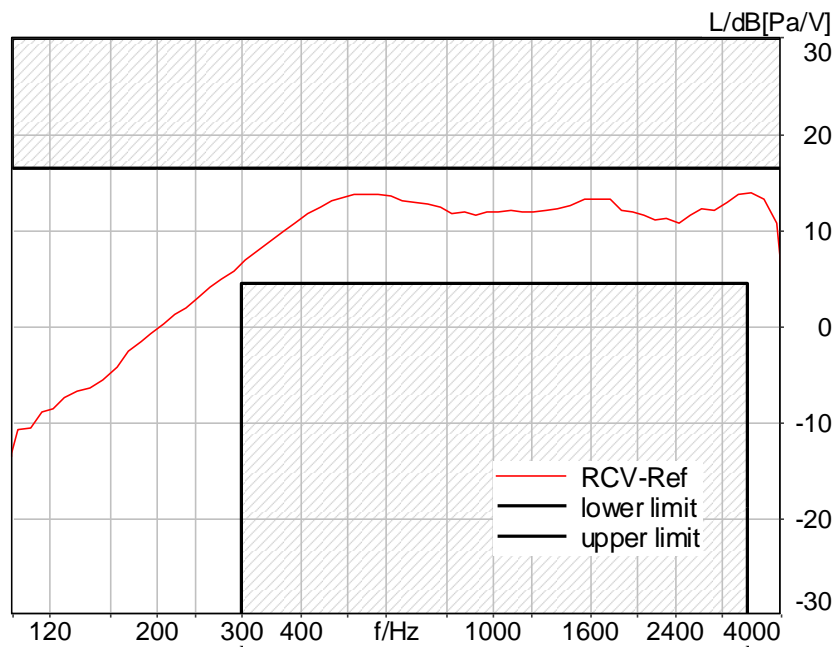

Figure C.3-6 – LTE Band 4 8N FF Narrowband Frequency Response

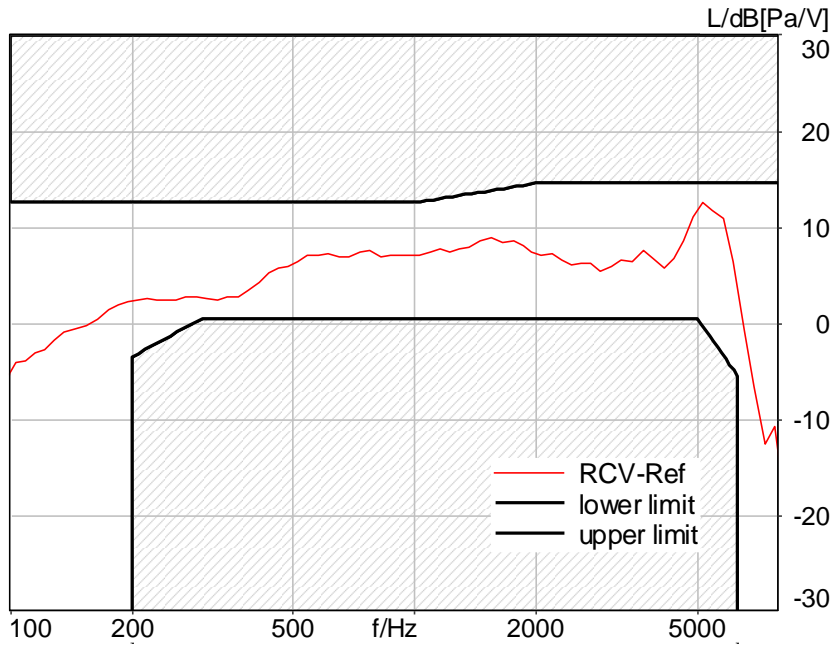

Figure C.3-7 – LTE Band 4 2N FF Wideband Frequency Response

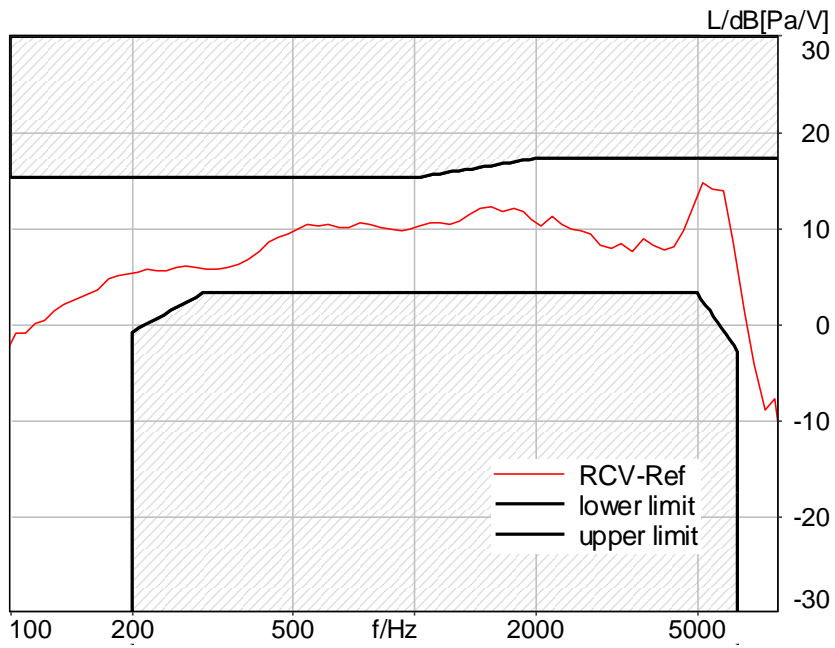

Figure C.3-8 – LTE Band 4 8N FF Wideband Frequency Response

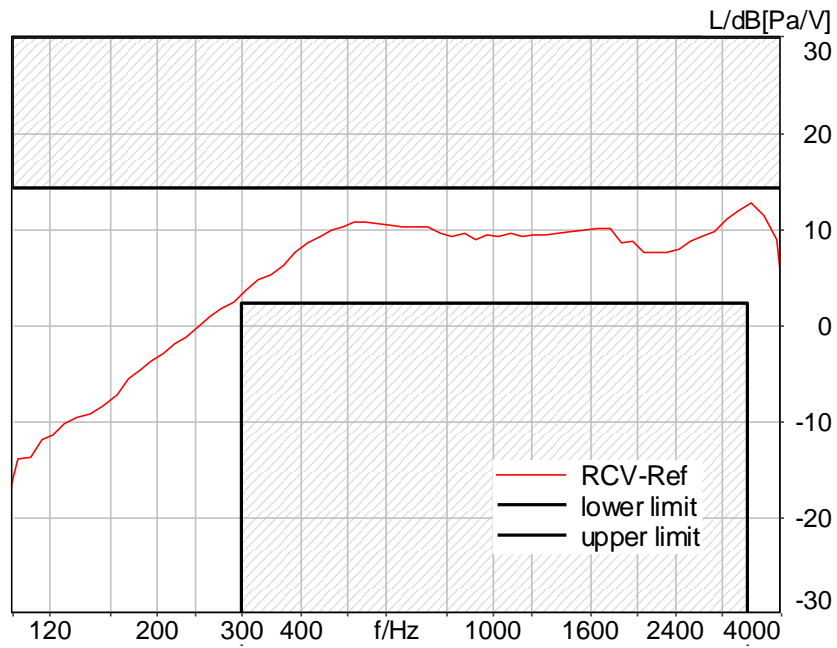

Figure C.3-9 – LTE Band 5 2N FF Narrowband Frequency Response

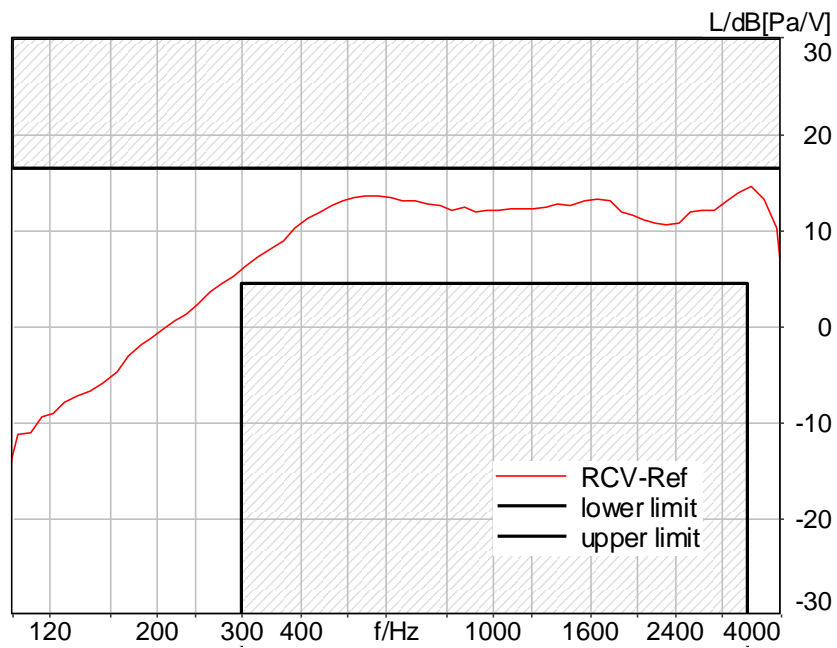

Figure C.3-10 – LTE Band 5 8N FF Narrowband Frequency Response

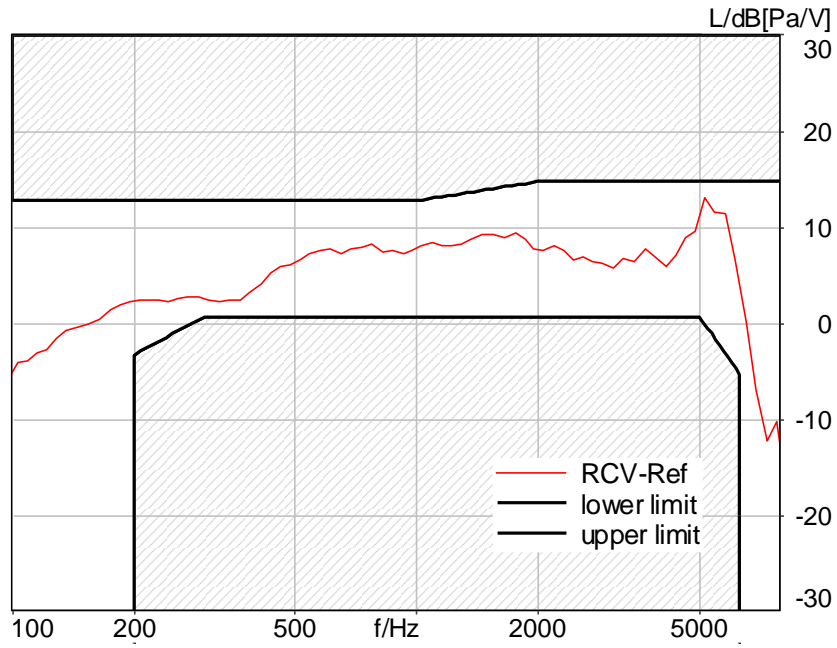

Figure C.3-11 – LTE Band 5 2N FF Wideband Frequency Response

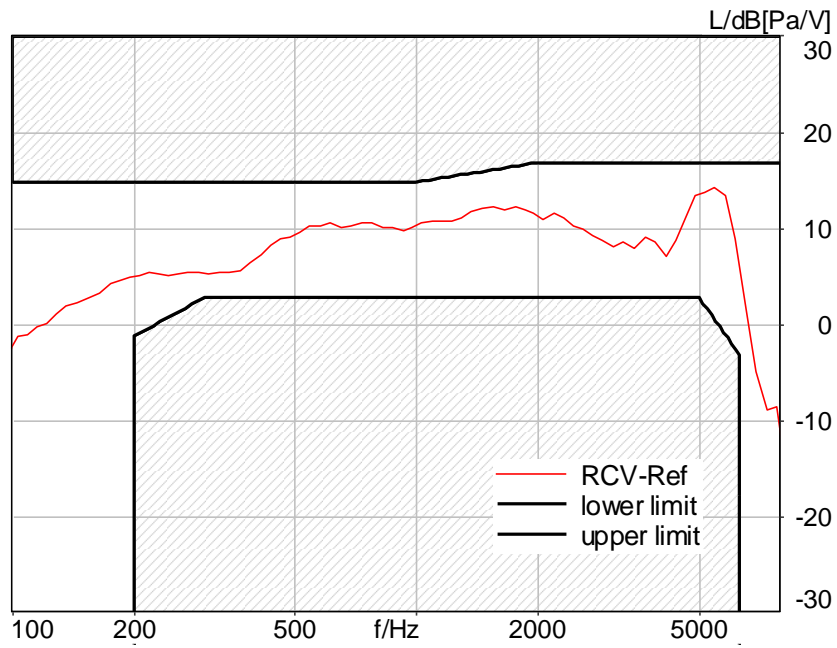

Figure C.3-12 – LTE Band 5 8N FF Wideband Frequency Response

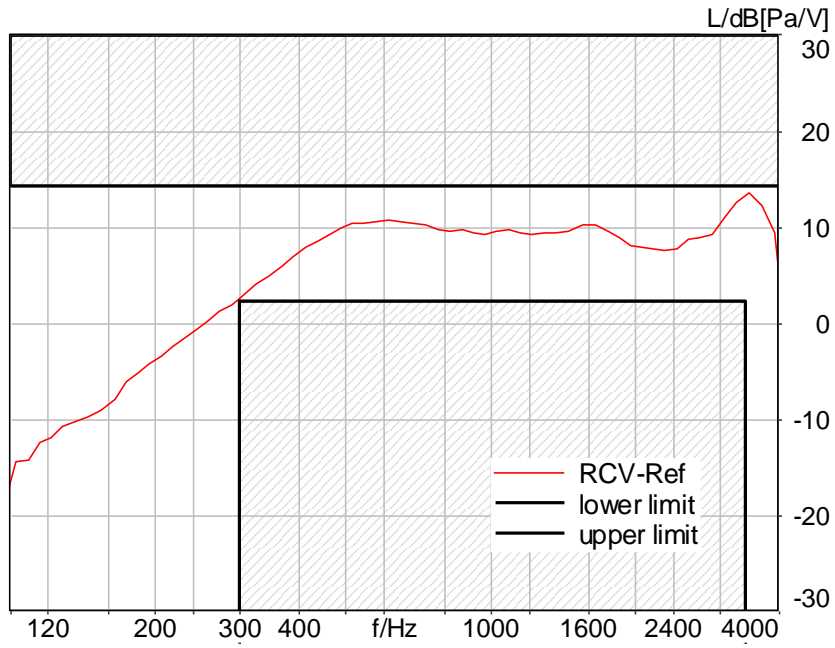

Figure C.3-13 – LTE Band 12 2N FF Narrowband Frequency Response

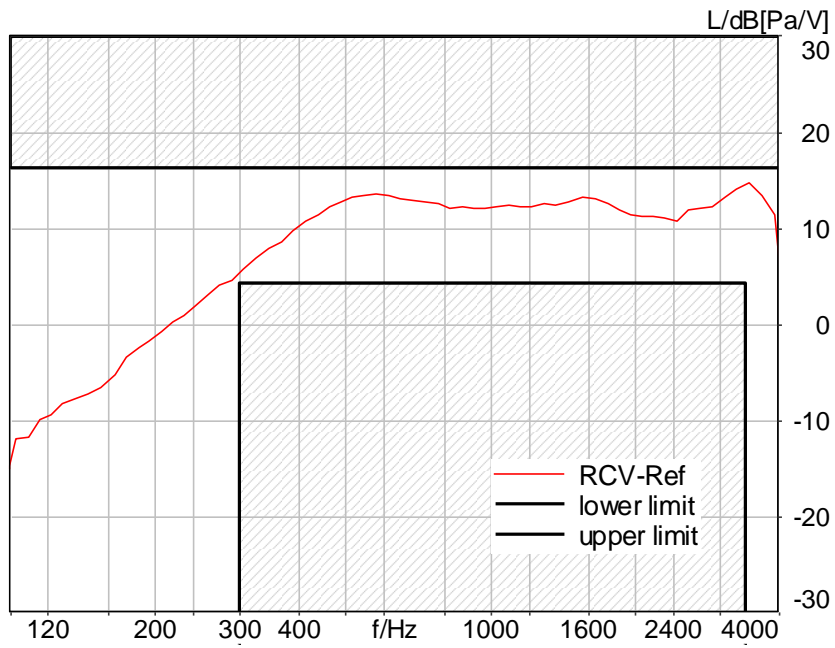

Figure C.3-14 – LTE Band 12 8N FF Narrowband Frequency Response

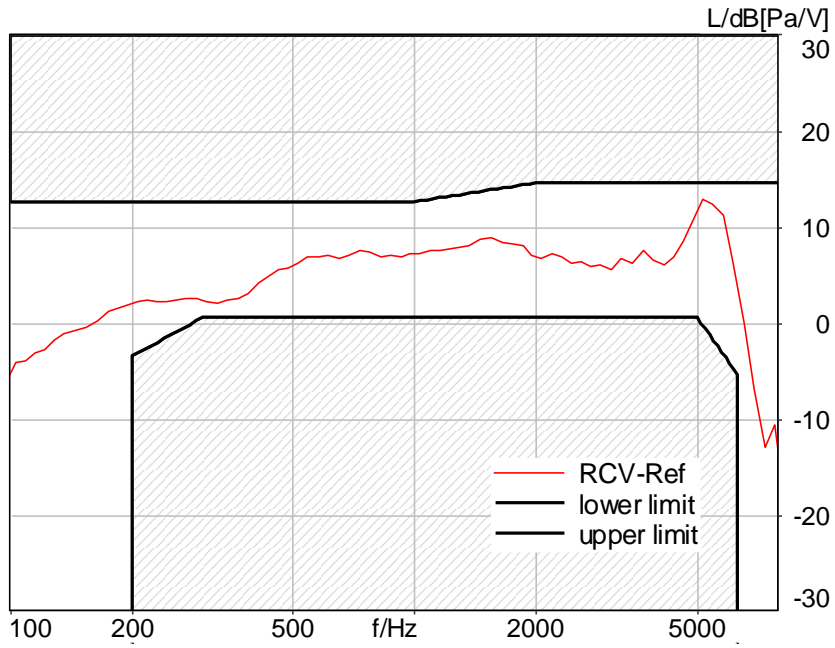

Figure C.3-15 – LTE Band 12 2N FF Wideband Frequency Response

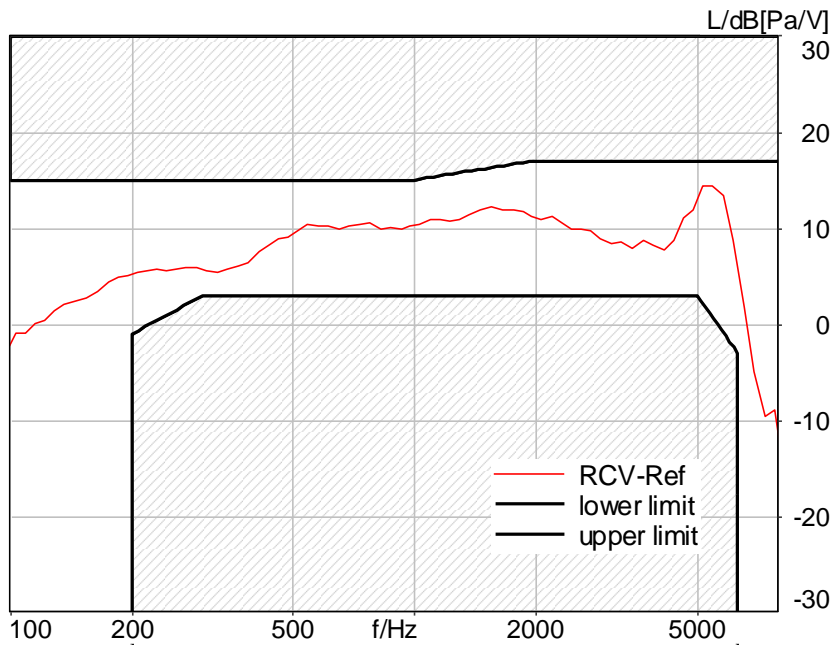

Figure C.3-16 – LTE Band 12 8N FF Wideband Frequency Response

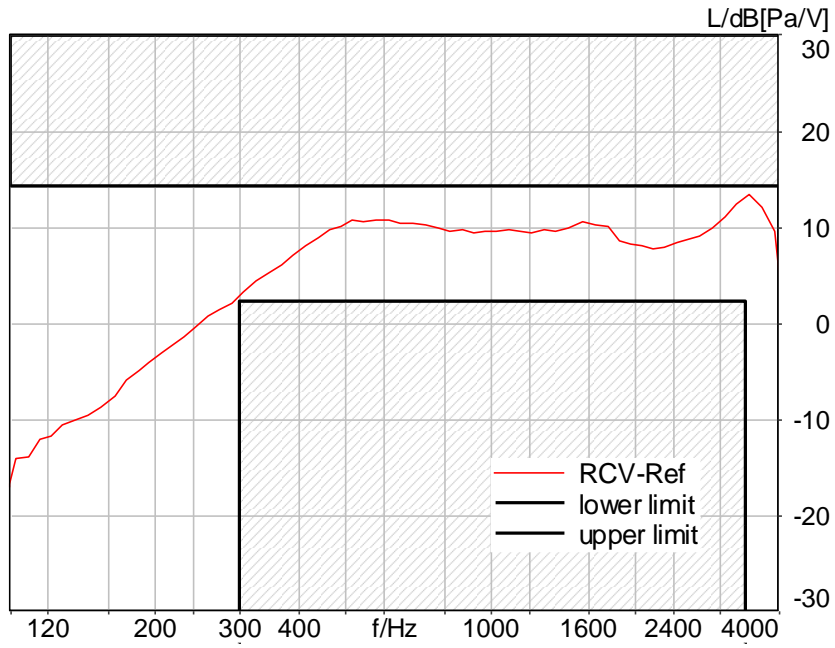

Figure C.3-17 – LTE Band 13 2N FF Narrowband Frequency Response

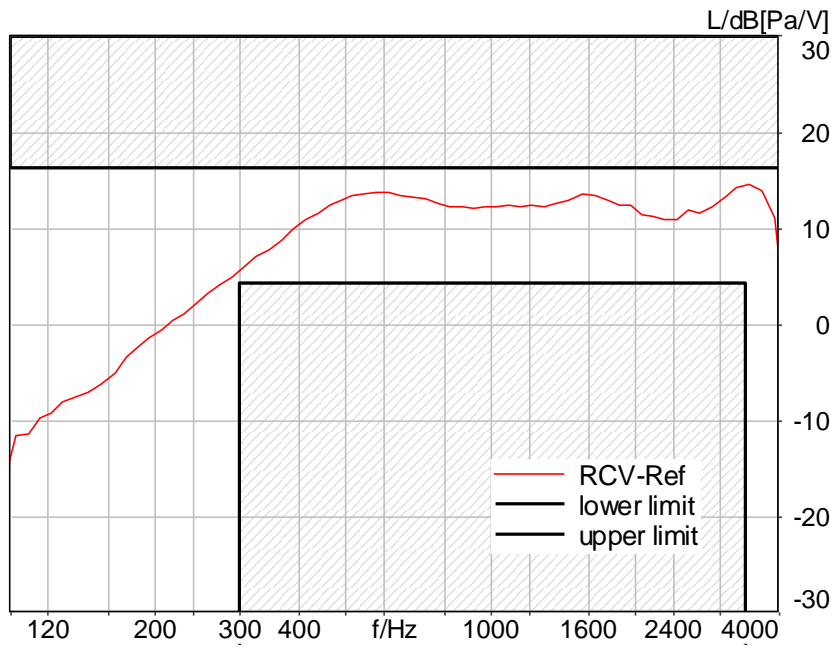

Figure C.3-18 – LTE Band 13 8N FF Narrowband Frequency Response

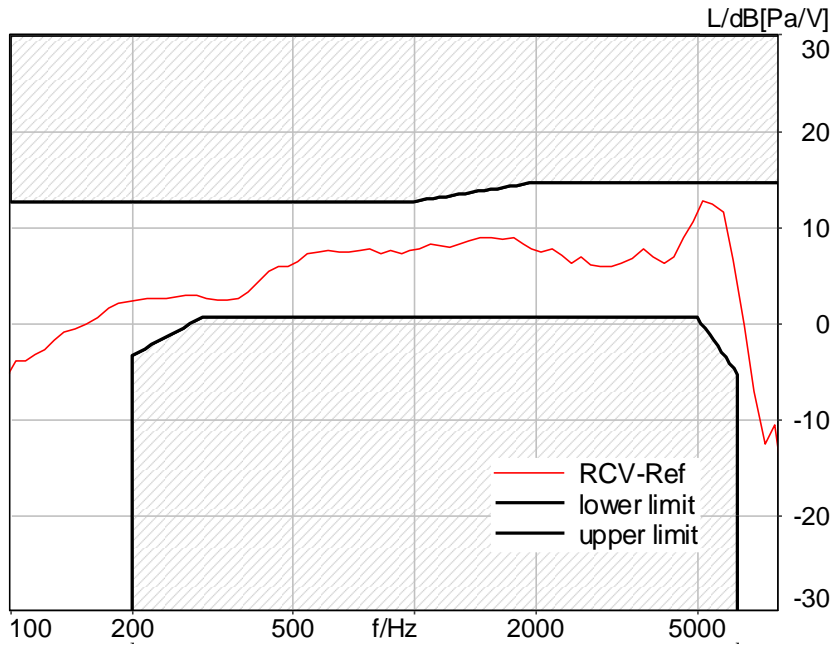

Figure C.3-19 – LTE Band 13 2N FF Wideband Frequency Response

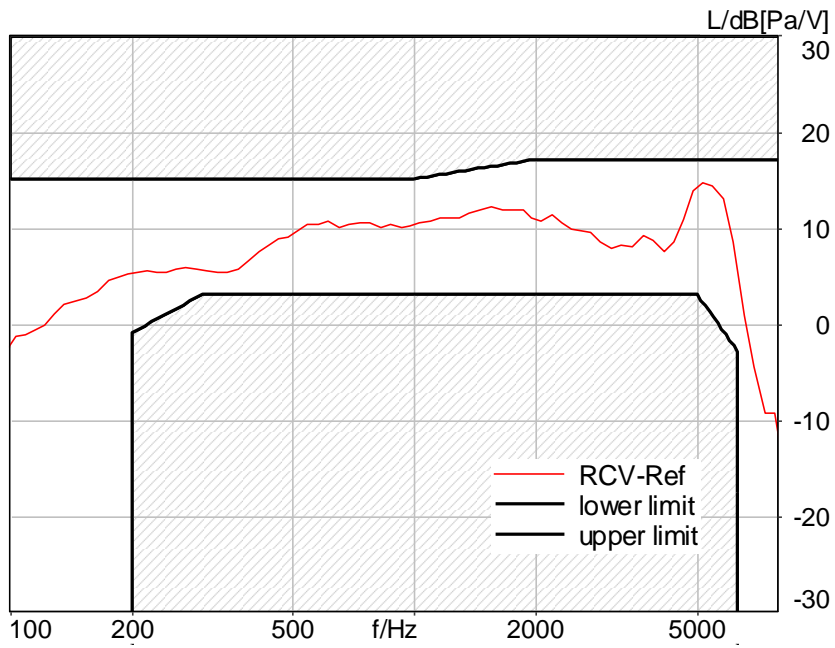

Figure C.3-20 – LTE Band 13 8N FF Wideband Frequency Response

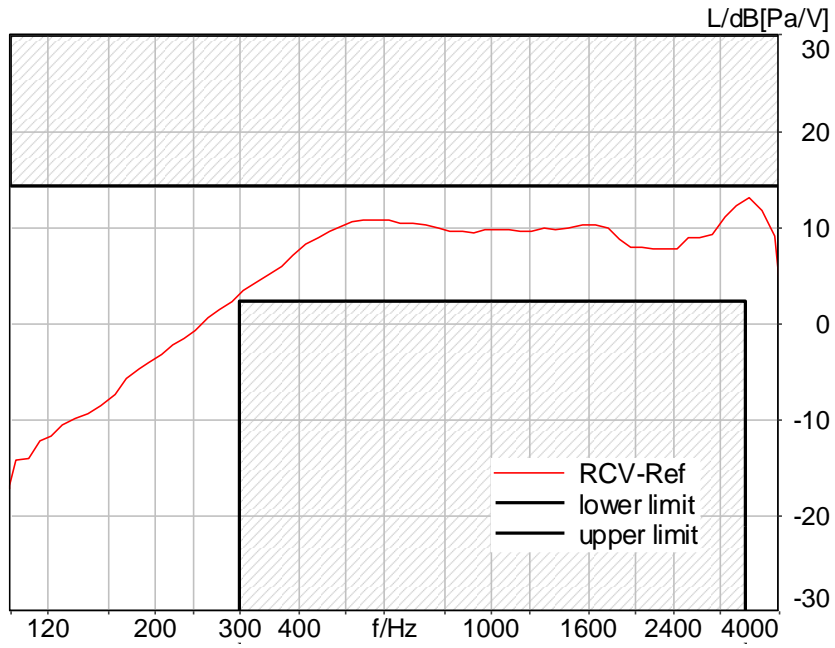

Figure C.3-21 – LTE Band 17 2N FF Narrowband Frequency Response

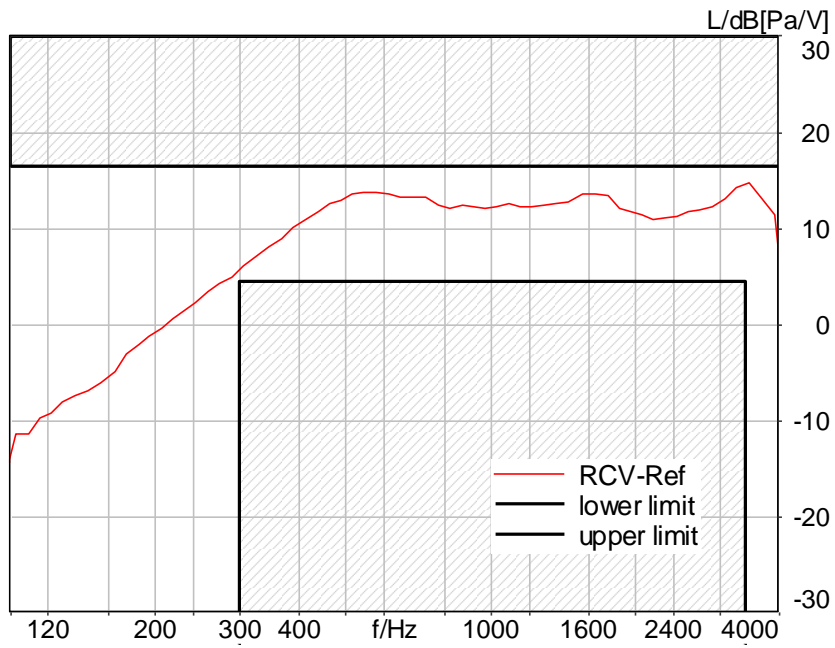

Figure C.3-22 – LTE Band 17 8N FF Narrowband Frequency Response

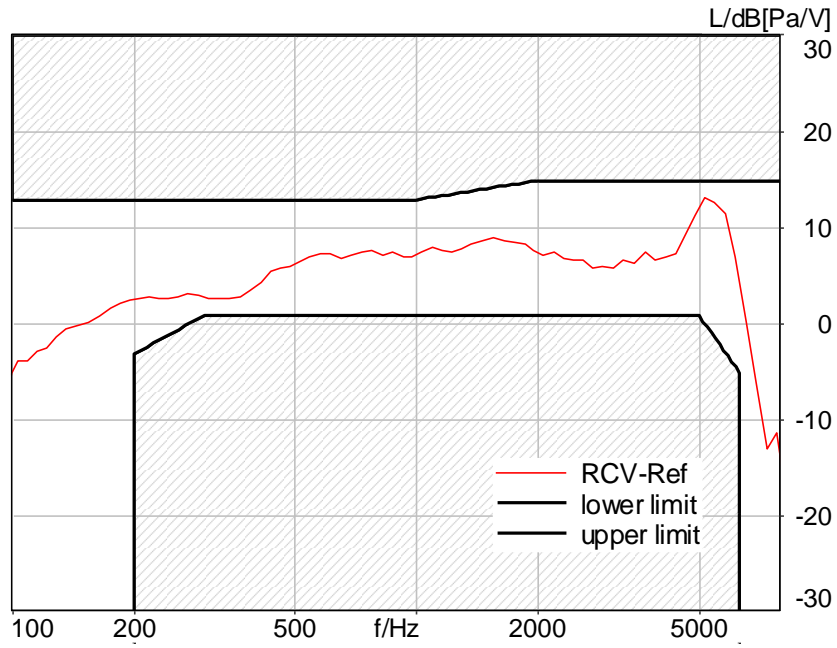

Figure C.3-23 – LTE Band 17 2N FF Wideband Frequency Response

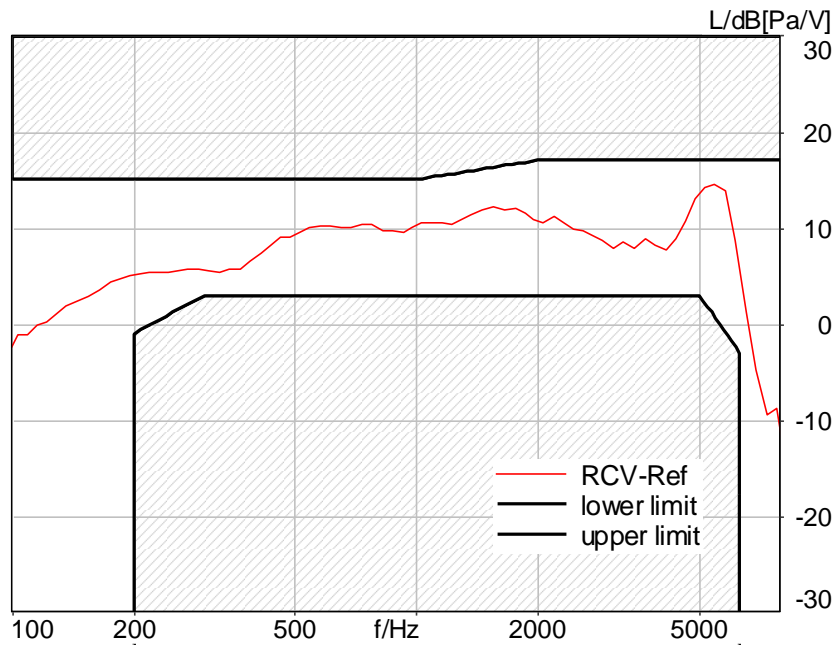

Figure C.3-24 – LTE Band 17 8N FF Wideband Frequency Response

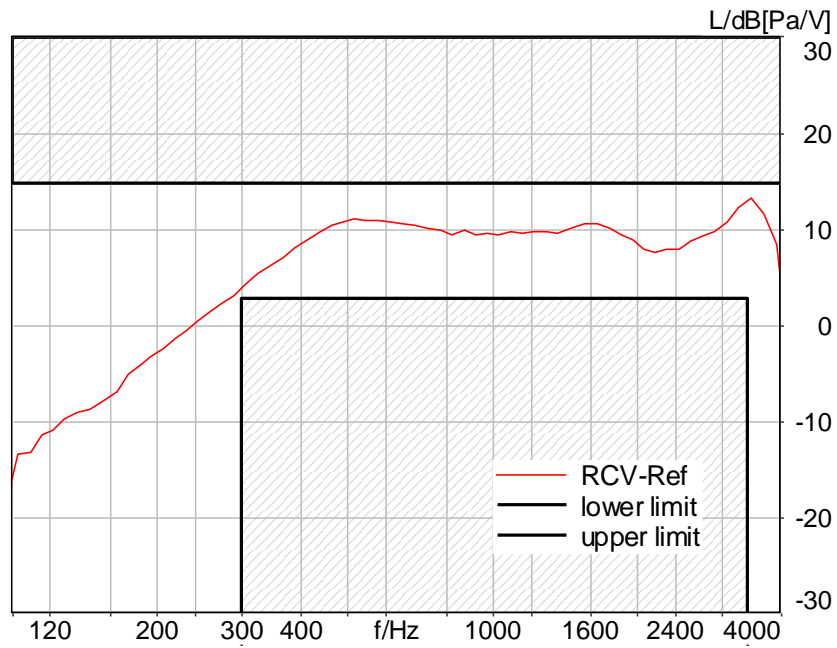

Figure C.3-25 – LTE Band 25 2N FF Narrowband Frequency Response

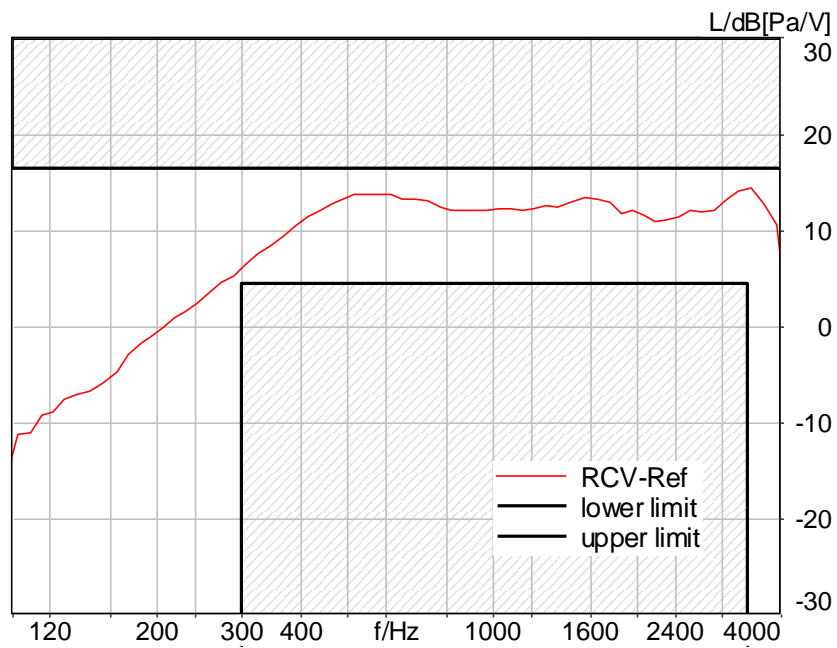

Figure C.3-26 – LTE Band 25 8N FF Narrowband Frequency Response

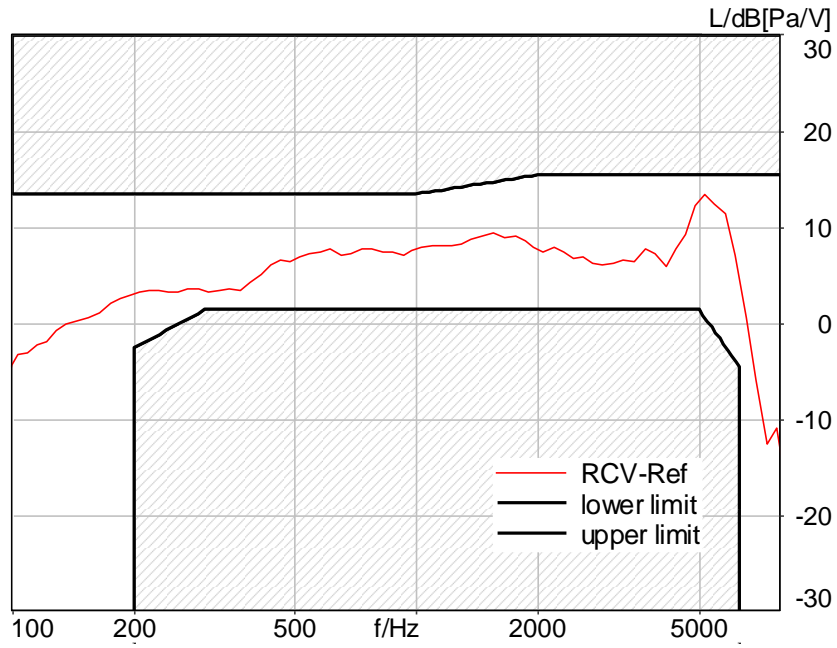

Figure C.3-27 – LTE Band 25 2N FF Wideband Frequency Response

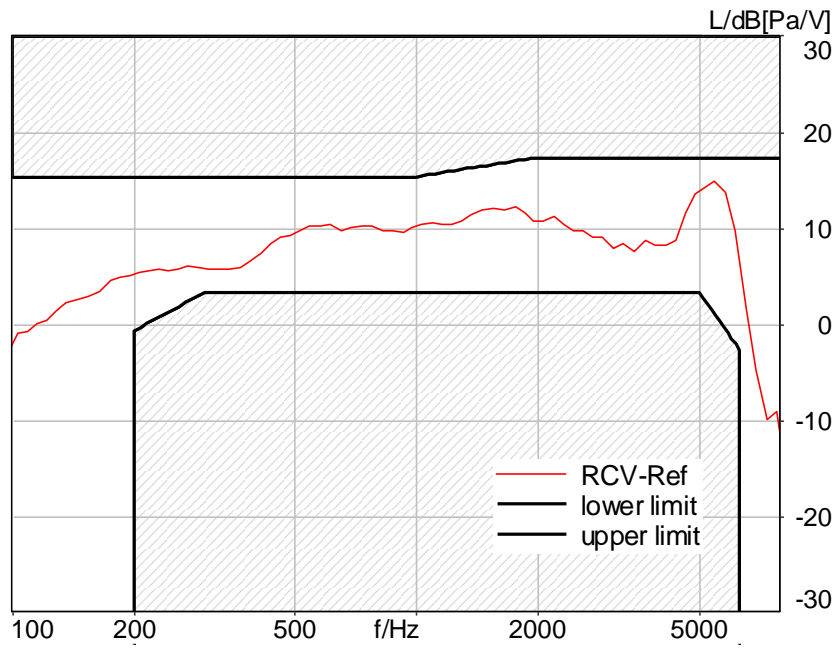

Figure C.3-28 – LTE Band 25 8N FF Wideband Frequency Response

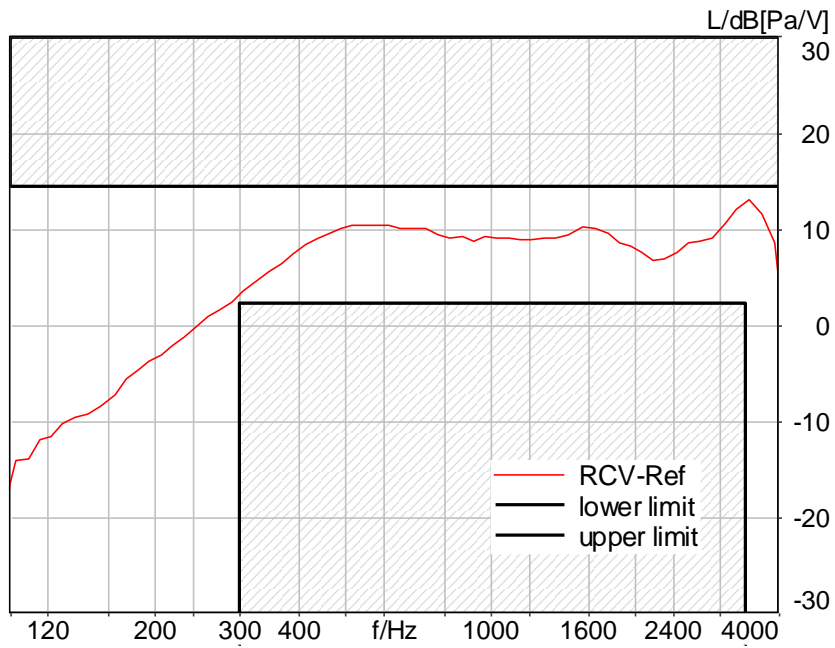

Figure C.3-29 – LTE Band 26 2N FF Narrowband Frequency Response

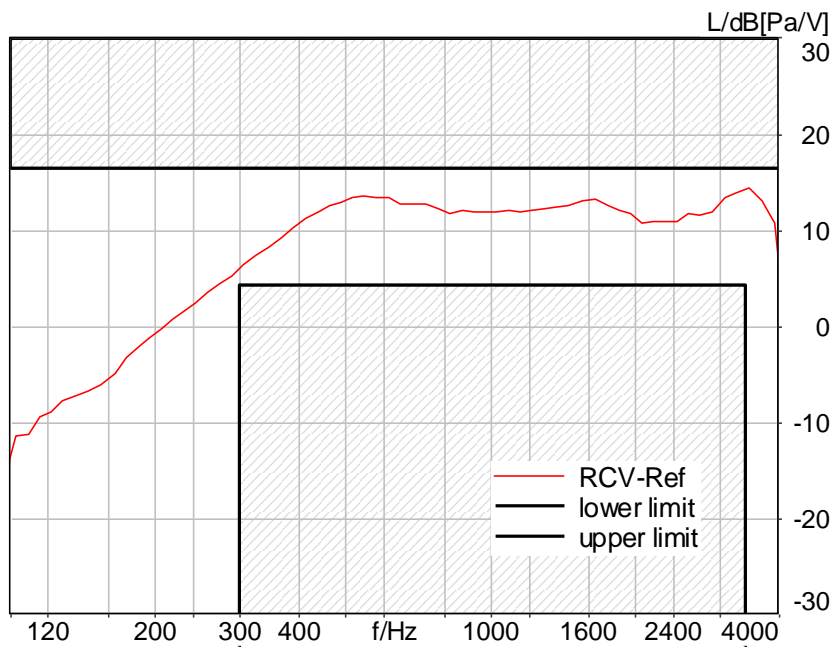

Figure C.3-30 – LTE Band 26 8N FF Narrowband Frequency Response

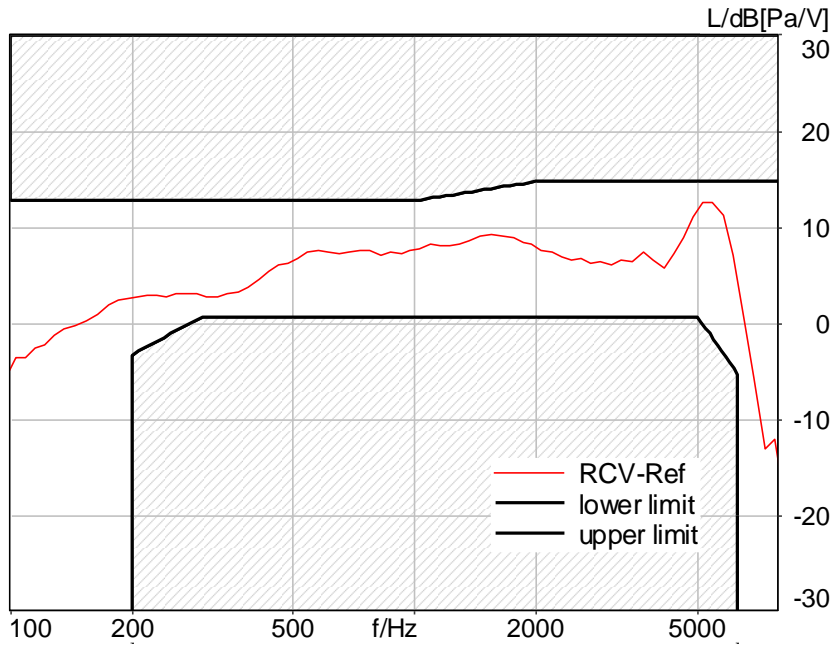

Figure C.3-31 – LTE Band 26 2N FF Wideband Frequency Response

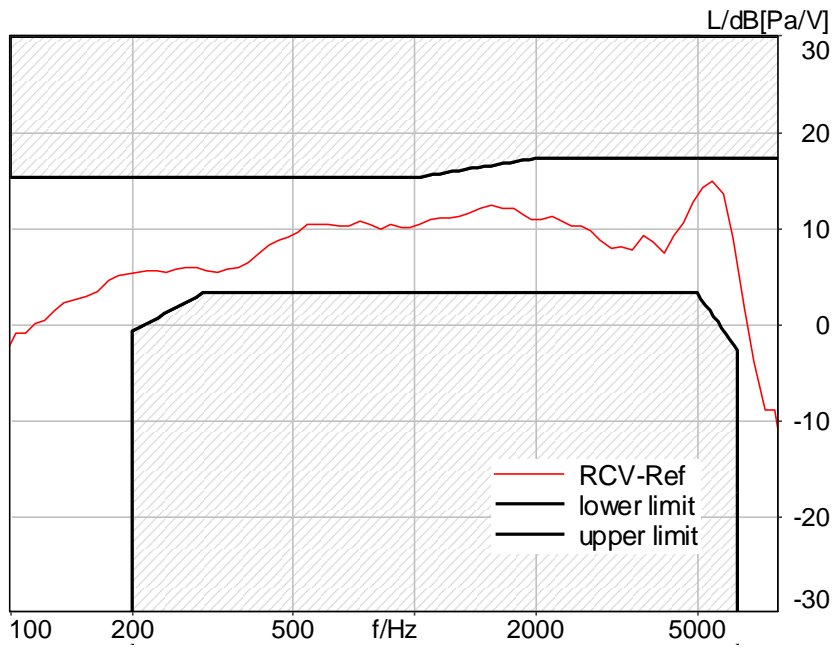

Figure C.3-32 – LTE Band 26 8N FF Wideband Frequency Response

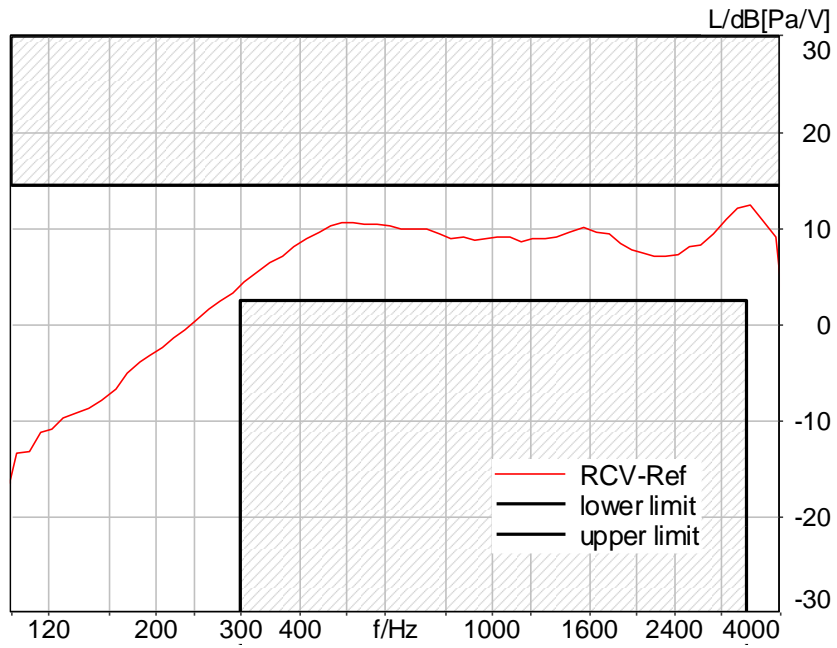

Figure C.3-33 – LTE Band 41 2N FF Narrowband Frequency Response

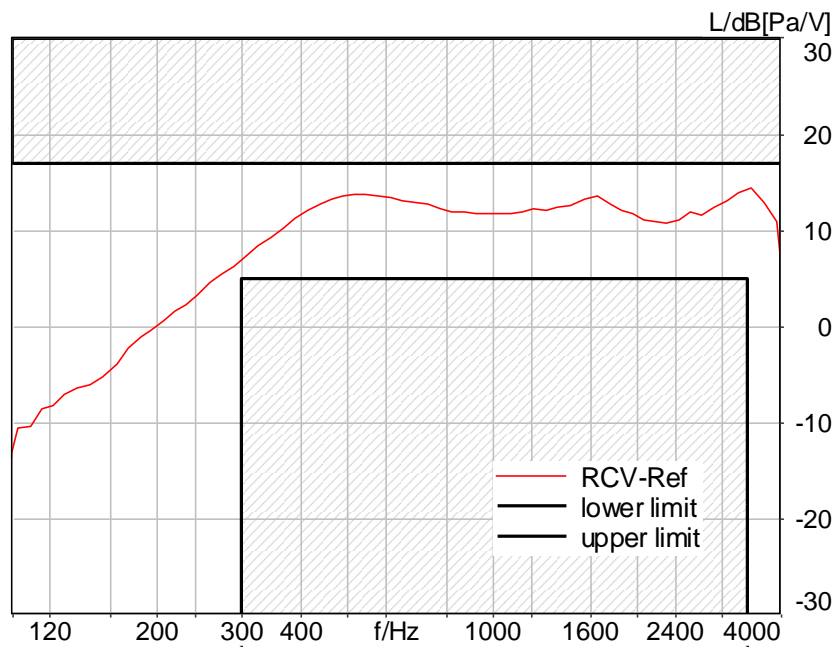

Figure C.3-34 – LTE Band 41 8N FF Narrowband Frequency Response

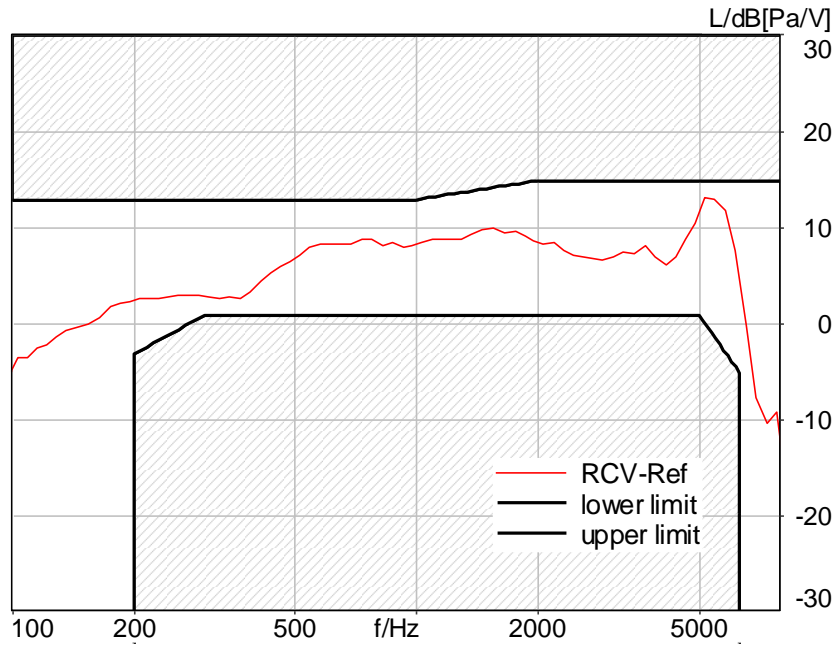

Figure C.3-35 – LTE Band 41 2N FF Wideband Frequency Response

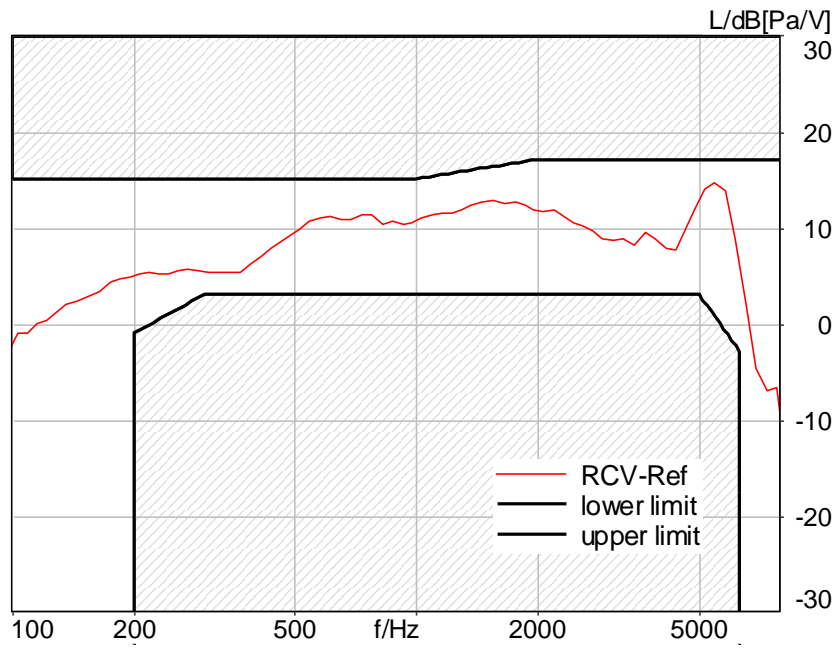

Figure C.3-36 – LTE Band 41 8N FF Wideband Frequency Response

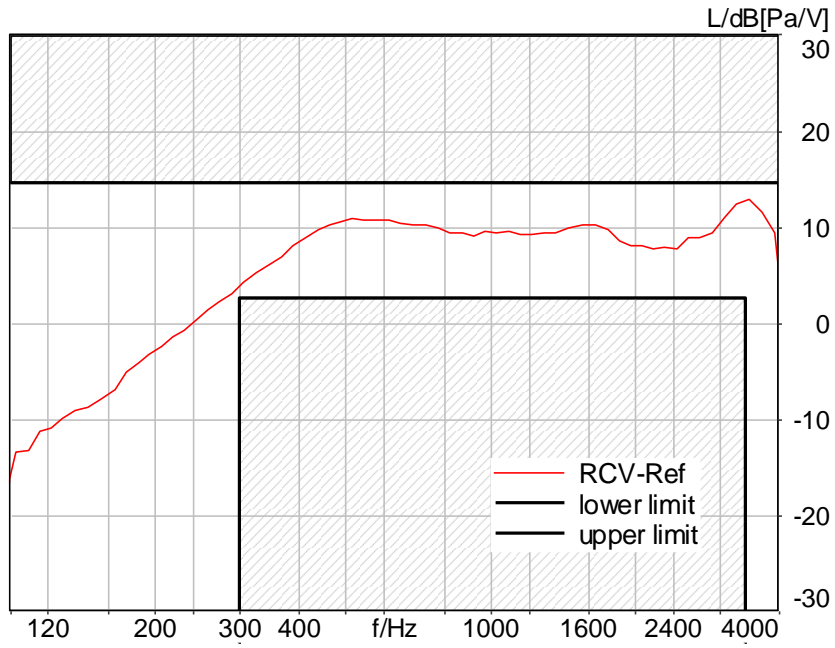

Figure C.3-37 – LTE Band 66 2N FF Narrowband Frequency Response

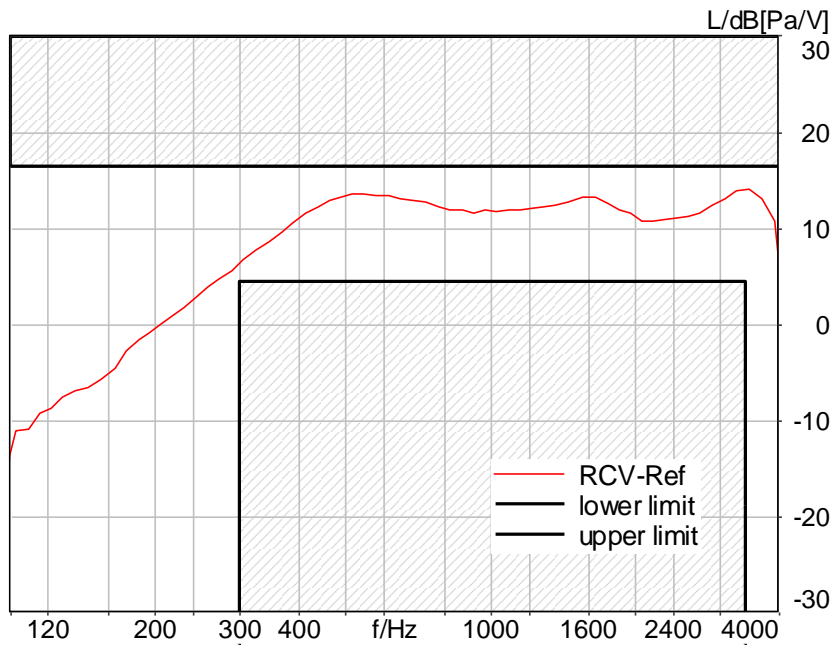

Figure C.3-38 – LTE Band 66 8N FF Narrowband Frequency Response

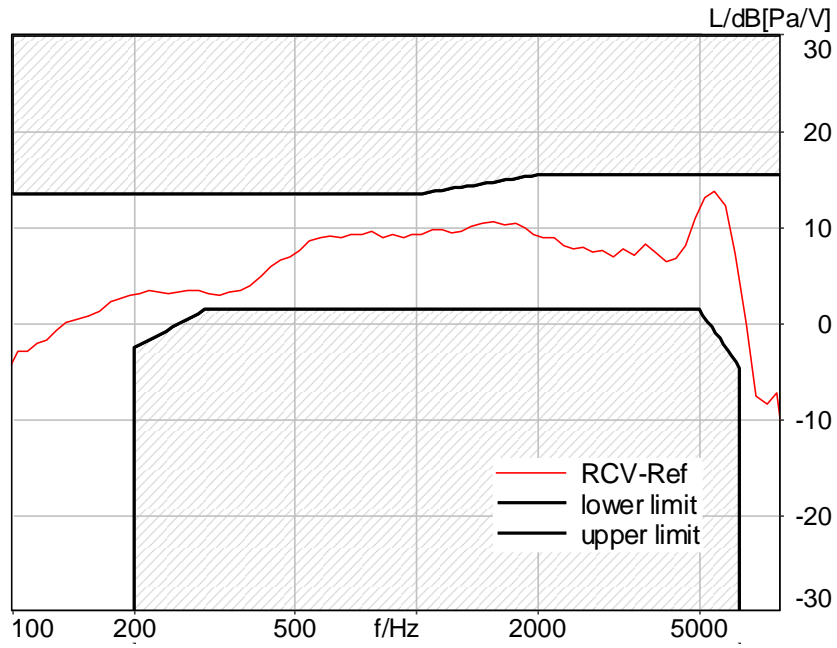

Figure C.3-39 – LTE Band 66 2N FF Wideband Frequency Response

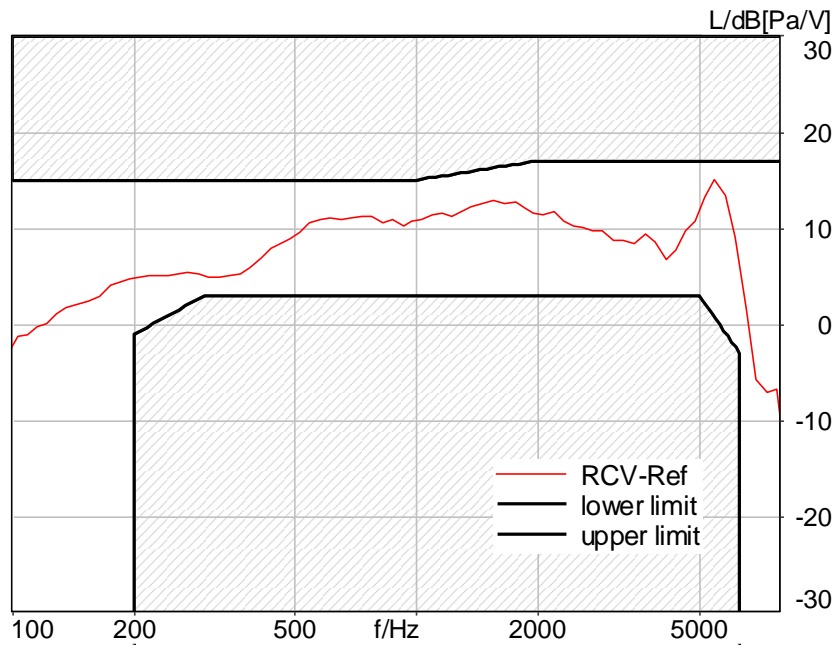

Figure C.3-40 – LTE Band 66 8N FF Wideband Frequency Response

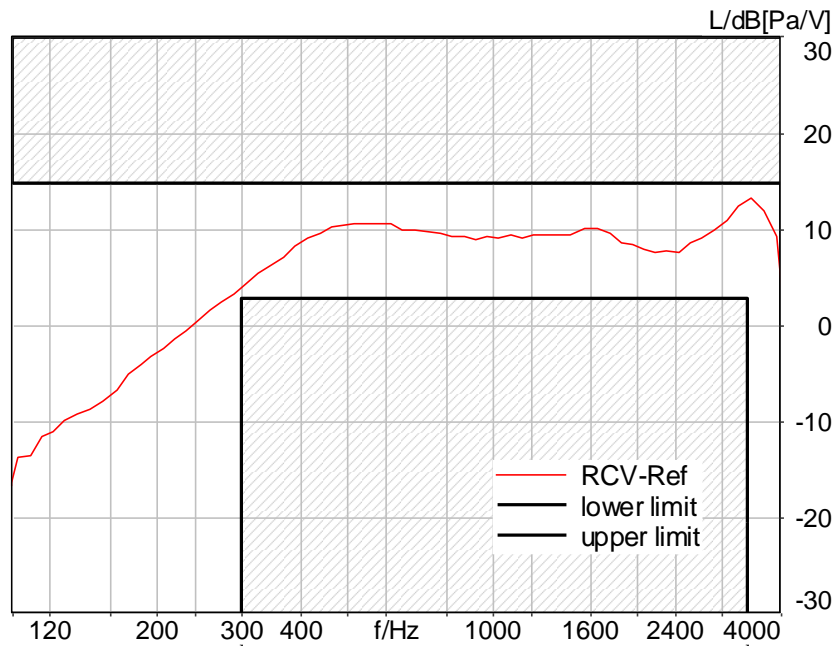

Figure C.3-41 – LTE Band 71 2N FF Narrowband Frequency Response

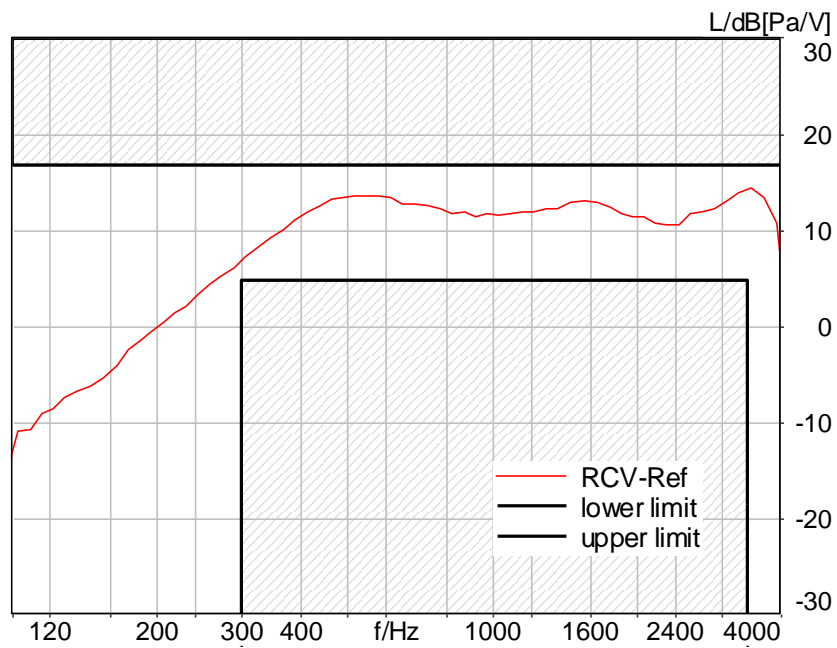

Figure C.3-42 – LTE Band 71 8N FF Narrowband Frequency Response

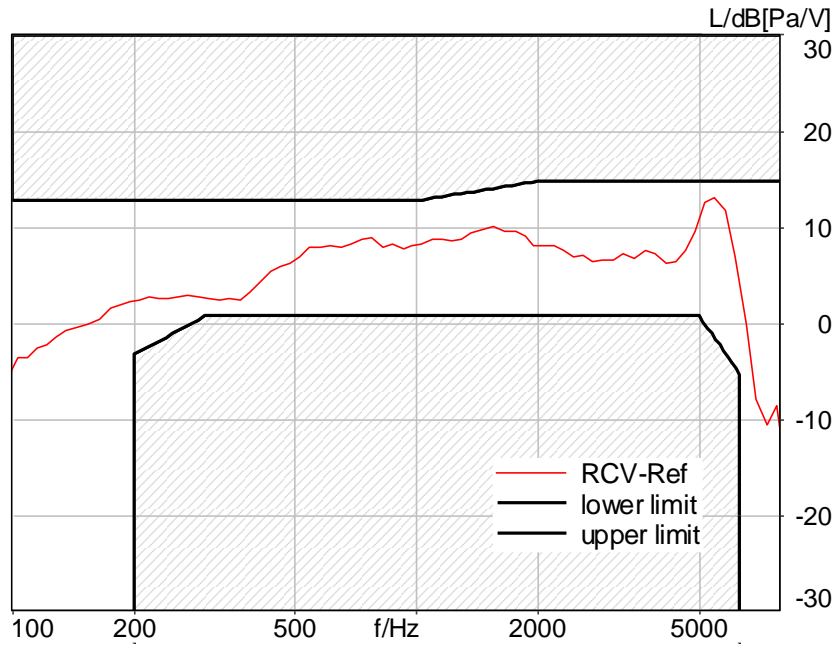

Figure C.3-43 – LTE Band 71 2N FF Wideband Frequency Response

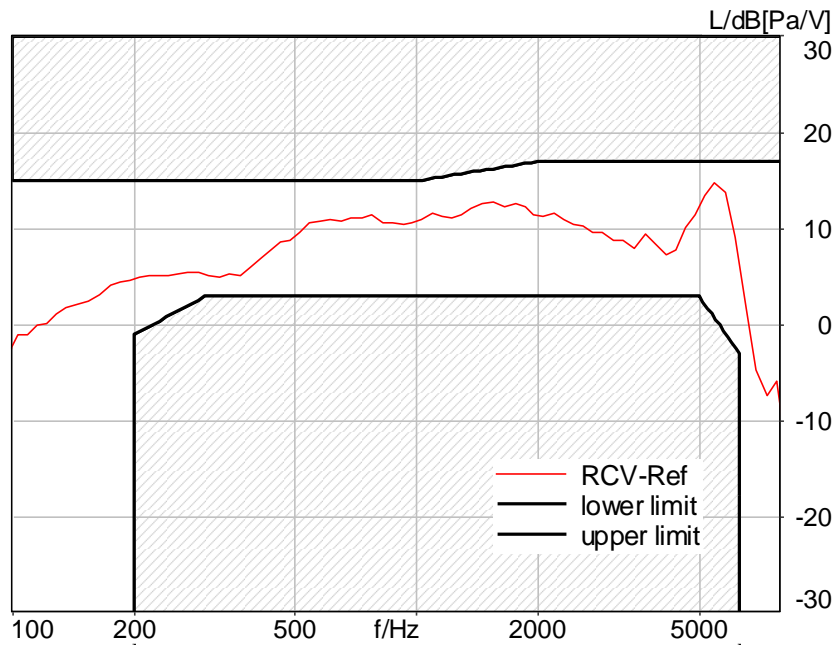

Figure C.3-44 – LTE Band 71 8N FF Wideband Frequency Response

C.4. WiFi Frequency Response Plots

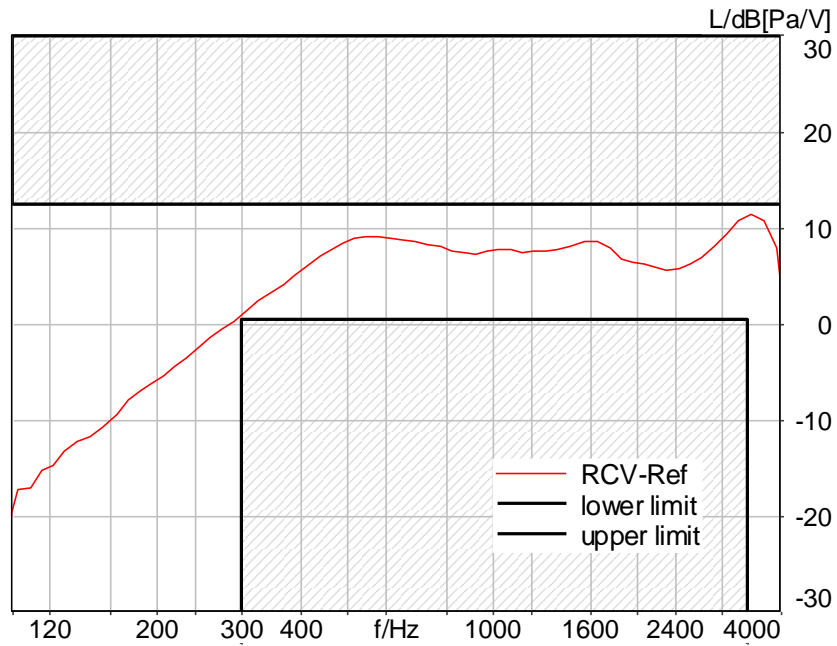

Figure C.4-1 – WLAN 2.4GHz 2N FF Narrowband Frequency Response

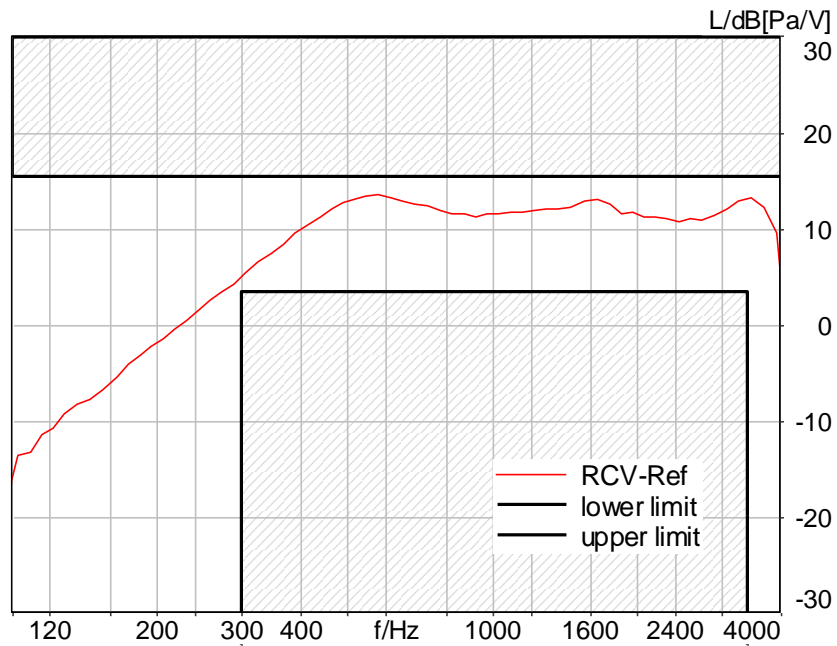

Figure C.4-2 – WLAN 2.4GHz 8N FF Narrowband Frequency Response

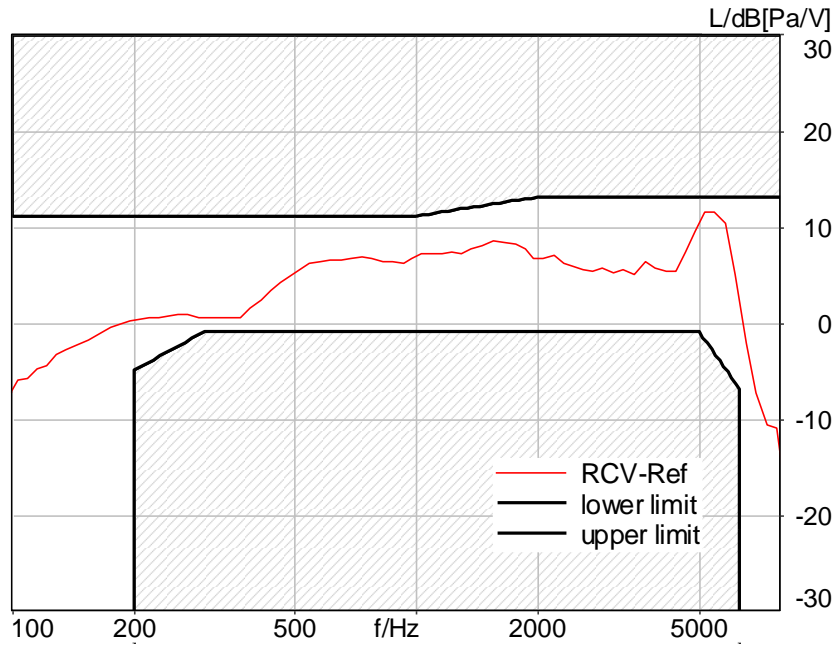

Figure C.4-3 – WLAN 2.4GHz 2N FF Wideband Frequency Response

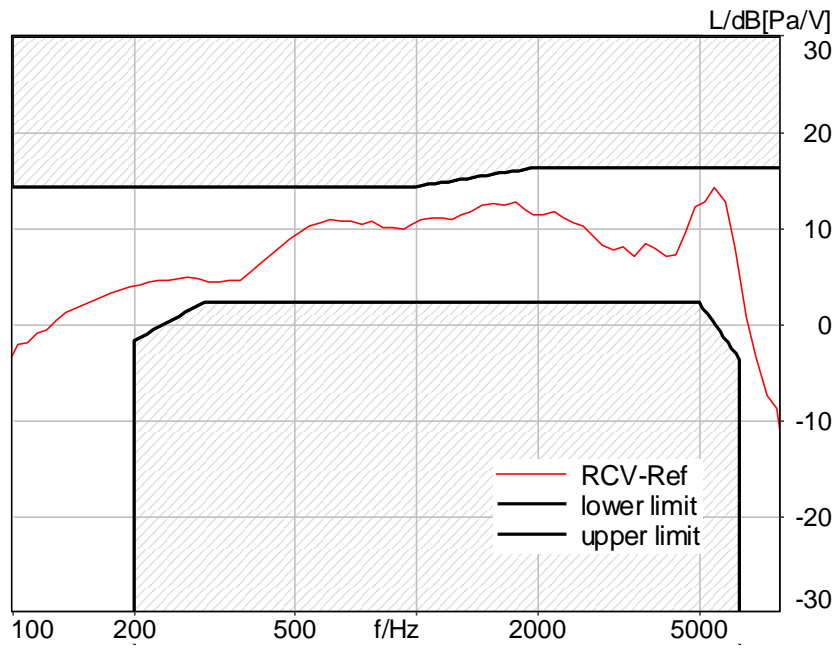

Figure C.4-4 – WLAN 2.4GHz 8N FF Wideband Frequency Response

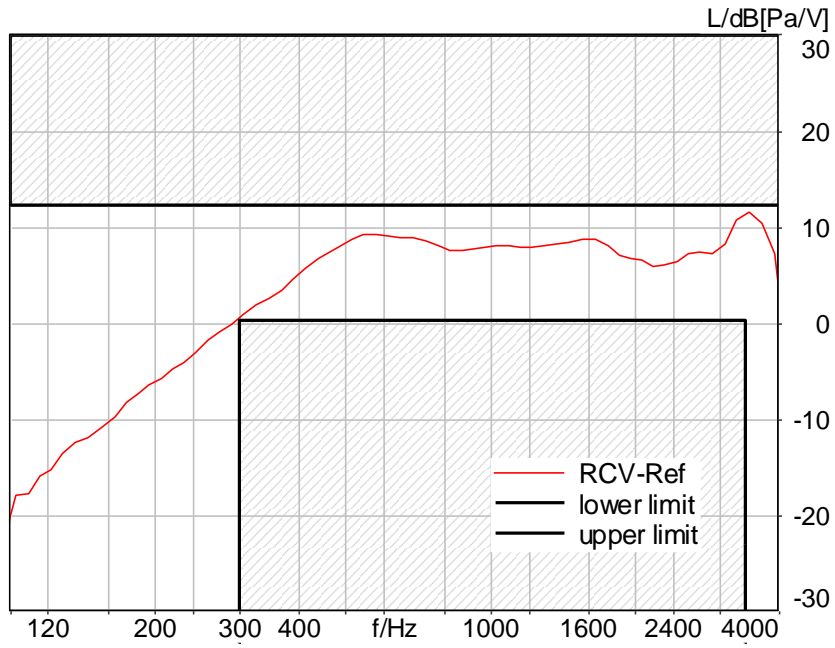

Figure C.4-5 – WLAN UNII-1 2N FF Narrowband Frequency Response

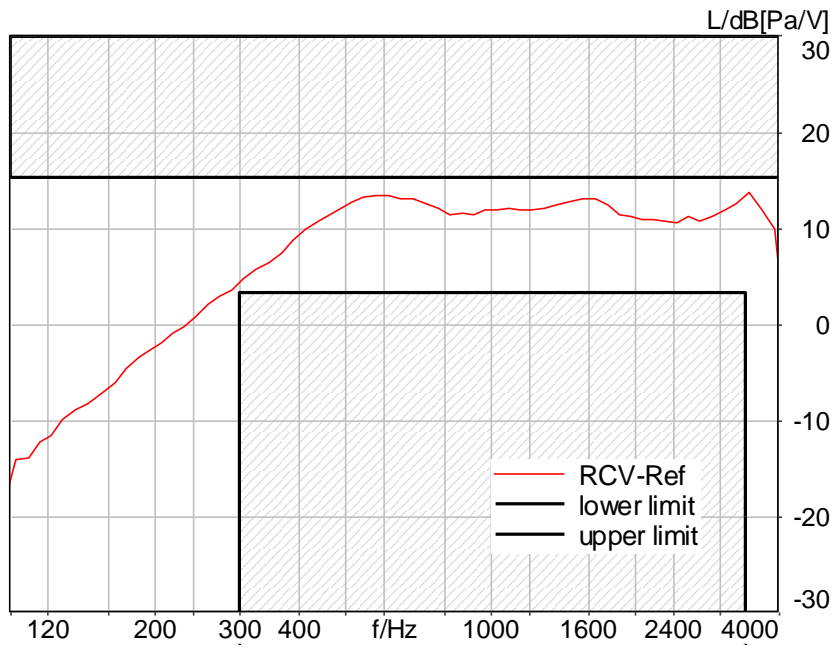

Figure C.4-6 – WLAN 2 UNII-1 8N FF Narrowband Frequency Response

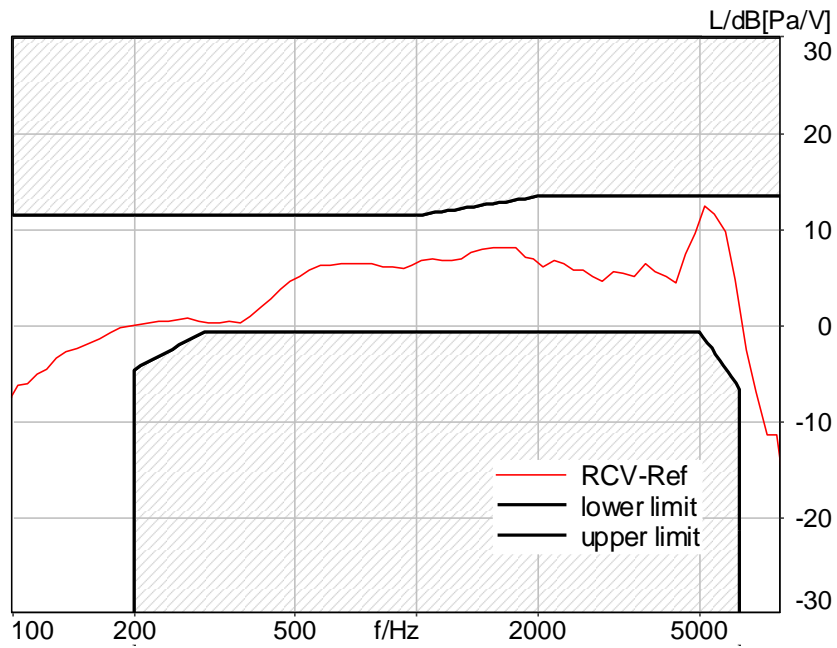

Figure C.4-7 – WLAN UNII-1 2N FF Wideband Frequency Response

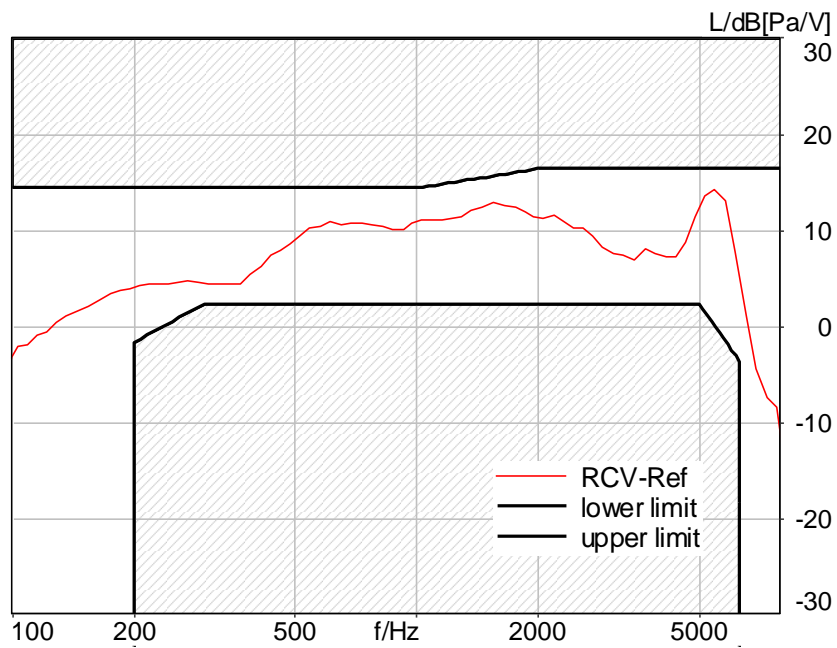

Figure C.4-8 – WLAN UNII-1 8N FF Wideband Frequency Response

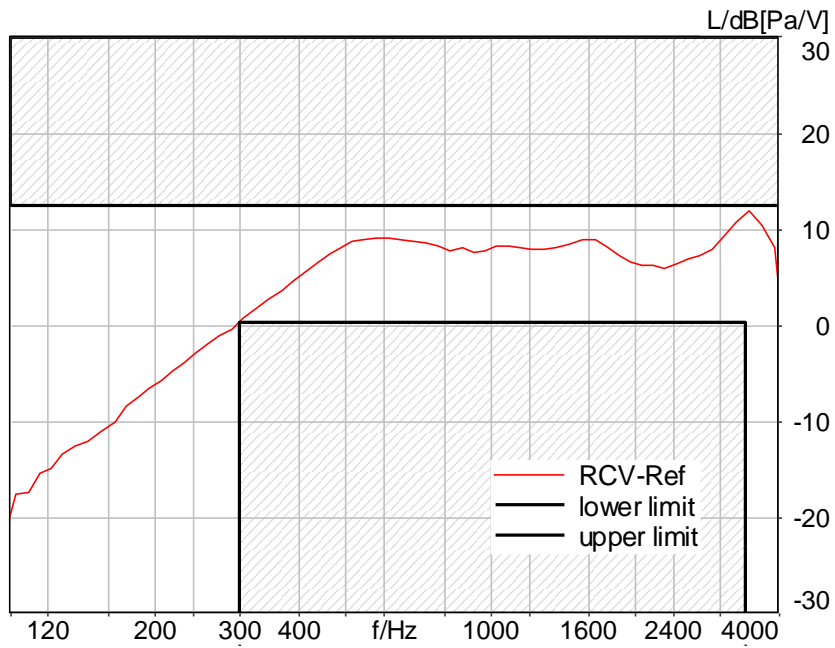

Figure C.4-9 – WLAN UNII-2A 2N FF Narrowband Frequency Response

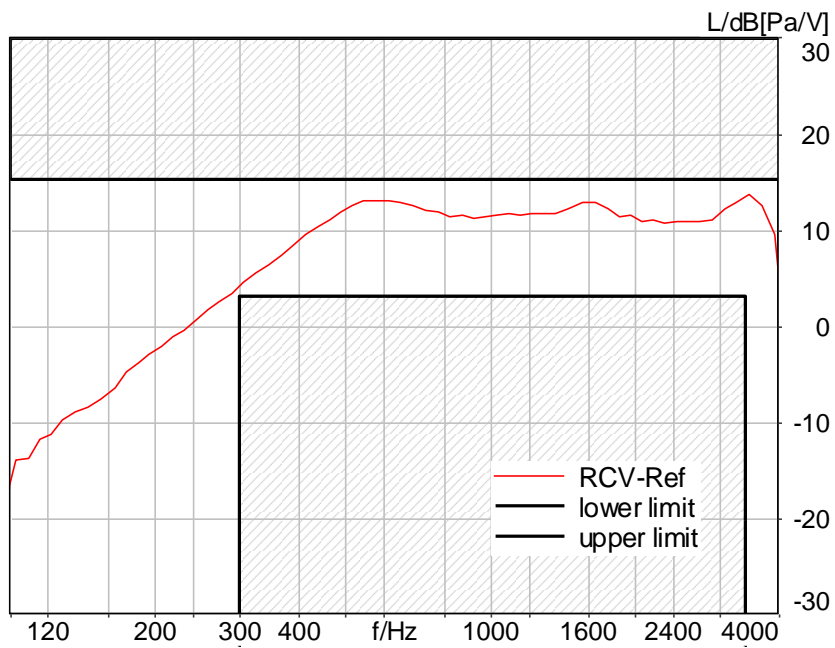

Figure C.4-10 – WLAN UNII-2A 8N FF Narrowband Frequency Response

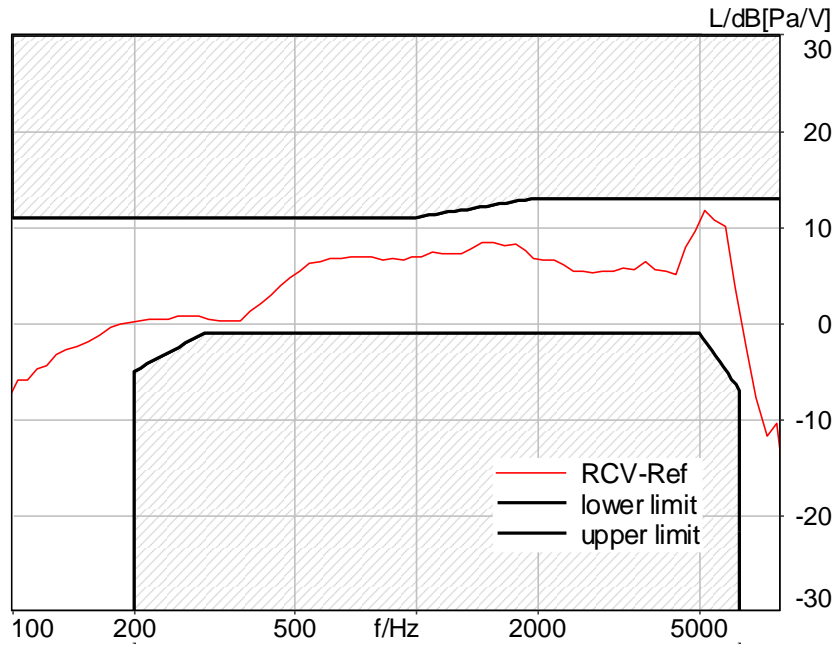

Figure C.4-11 – WLAN UNII-2A 2N FF Wideband Frequency Response

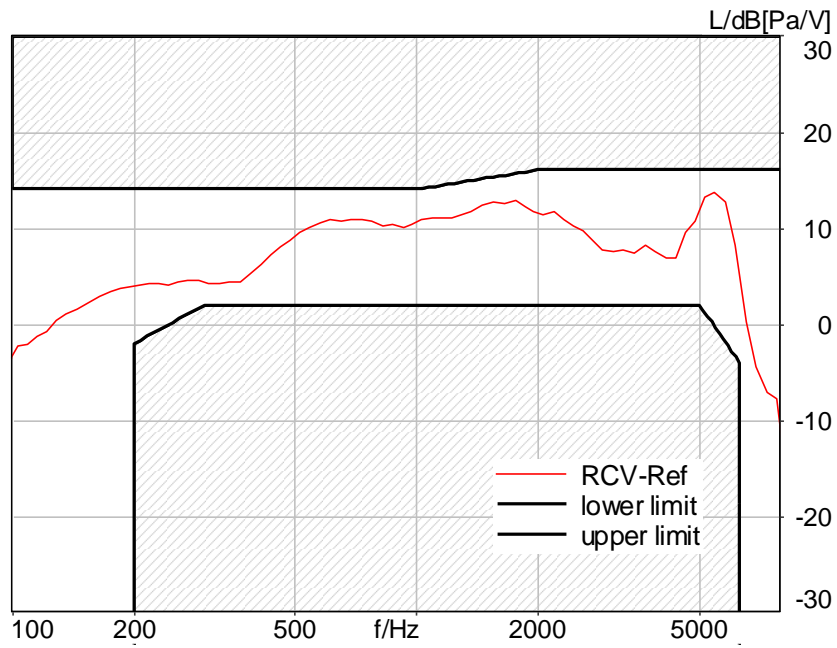

Figure C.4-12 – WLAN UNII-2A 8N FF Wideband Frequency Response

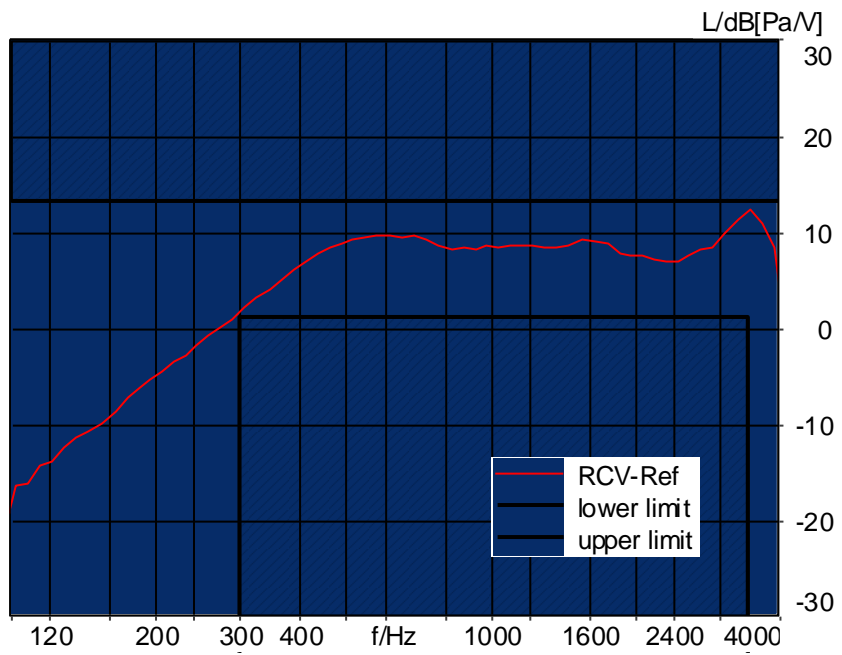

Figure C.4-13 – WLAN UNII-2C 2N FF Narrowband Frequency Response

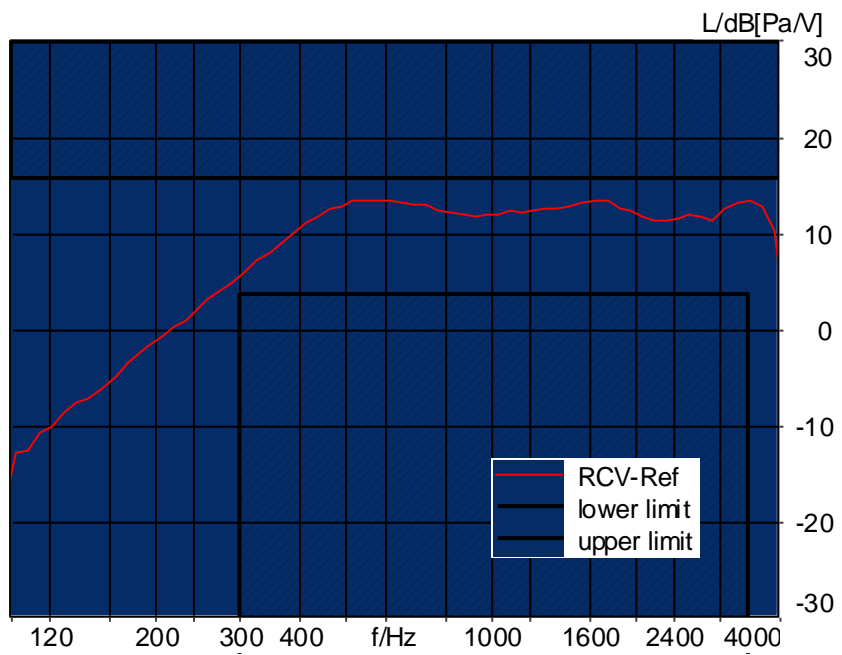

Figure C.4-14 – WLAN UNII-2C 8N FF Narrowband Frequency Response

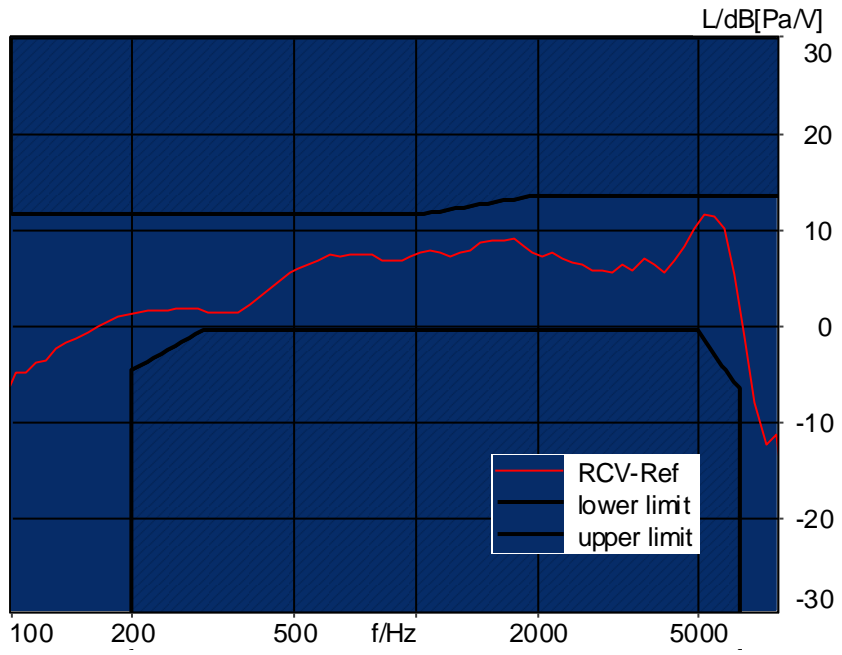

Figure C.4-15 – WLAN UNII-2C 2N FF Wideband Frequency Response

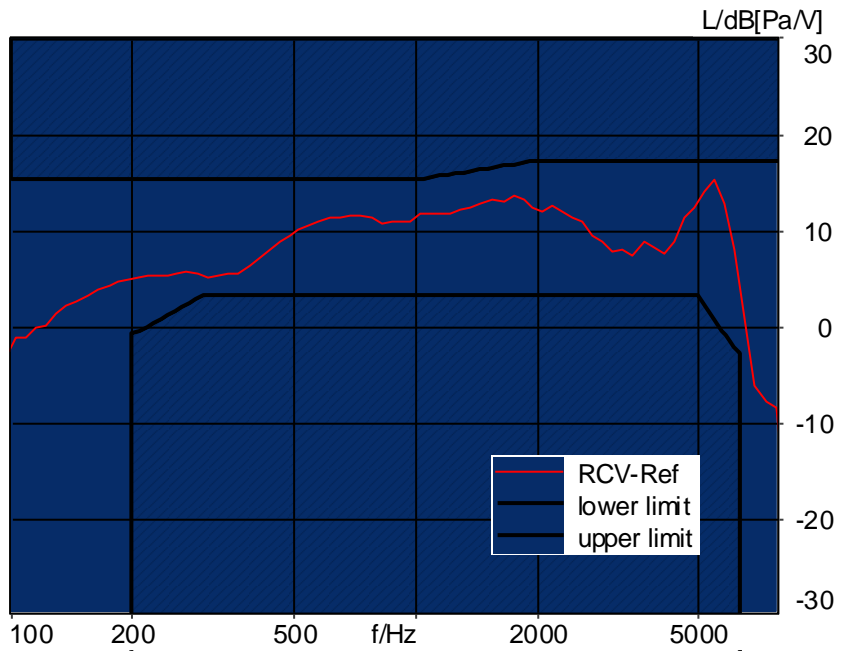

Figure C.4-16 – WLAN UNII-2C 8N FF Wideband Frequency Response

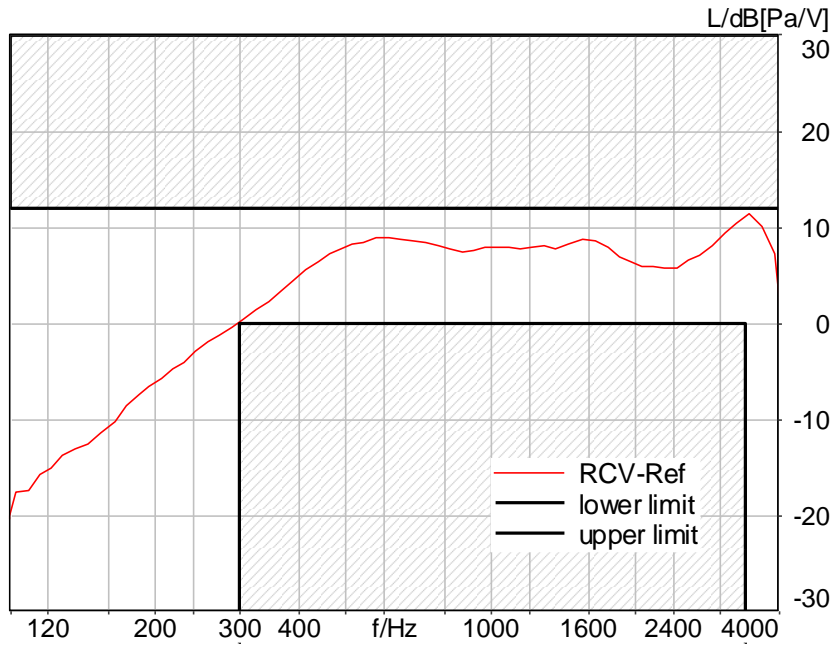

Figure C.4-17 – WLAN UNII-3 2N FF Narrowband Frequency Response

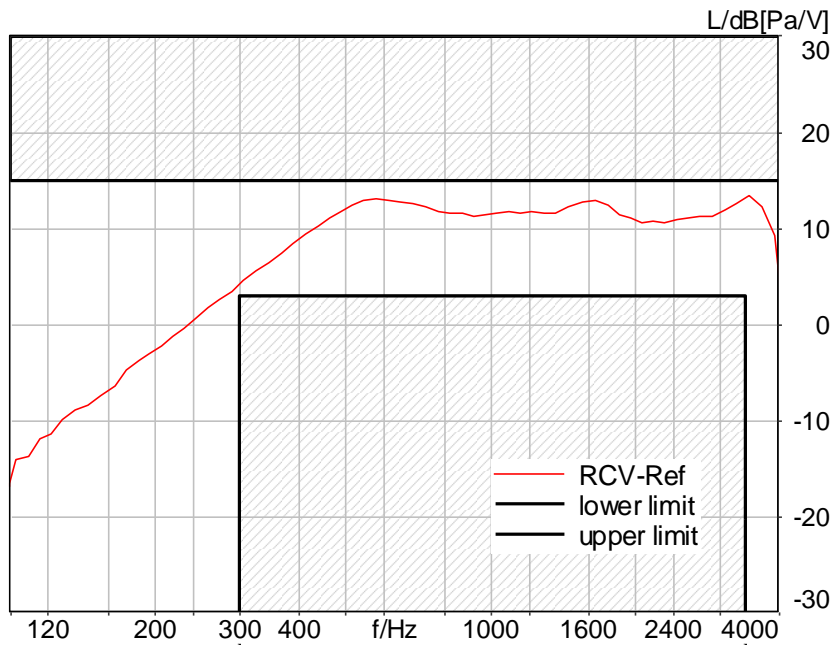

Figure C.4-18 – WLAN UNII-3 8N FF Narrowband Frequency Response

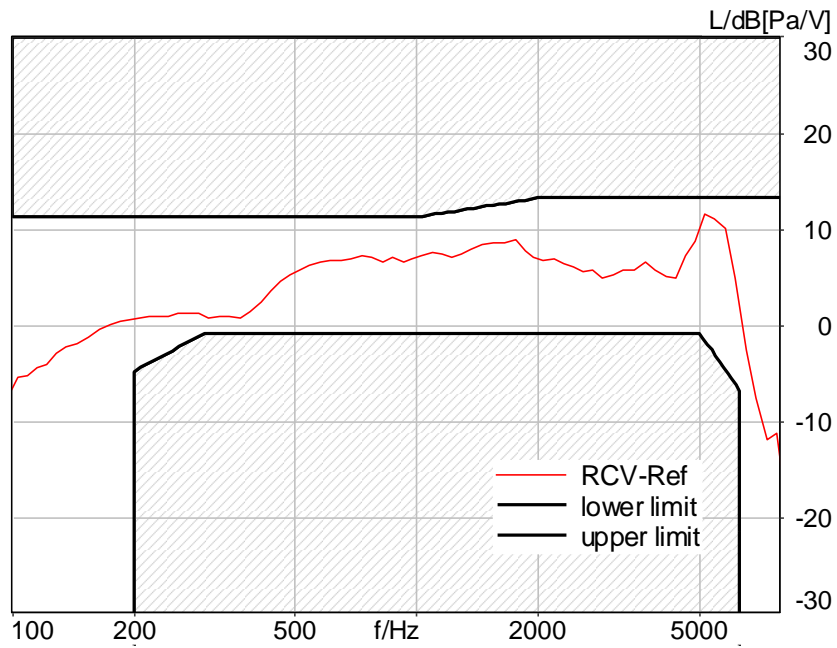

Figure C.4-19 – WLAN UNII-3 2N FF Wideband Frequency Response

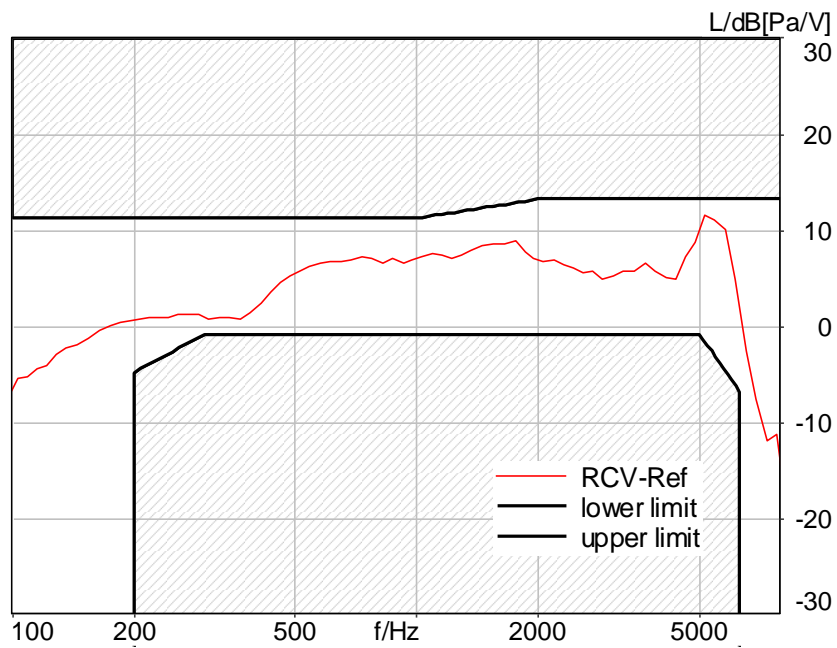

Figure C.4-20 – WLAN UNII-3 8N FF Wideband Frequency Response

ANNEX D EUT photograph

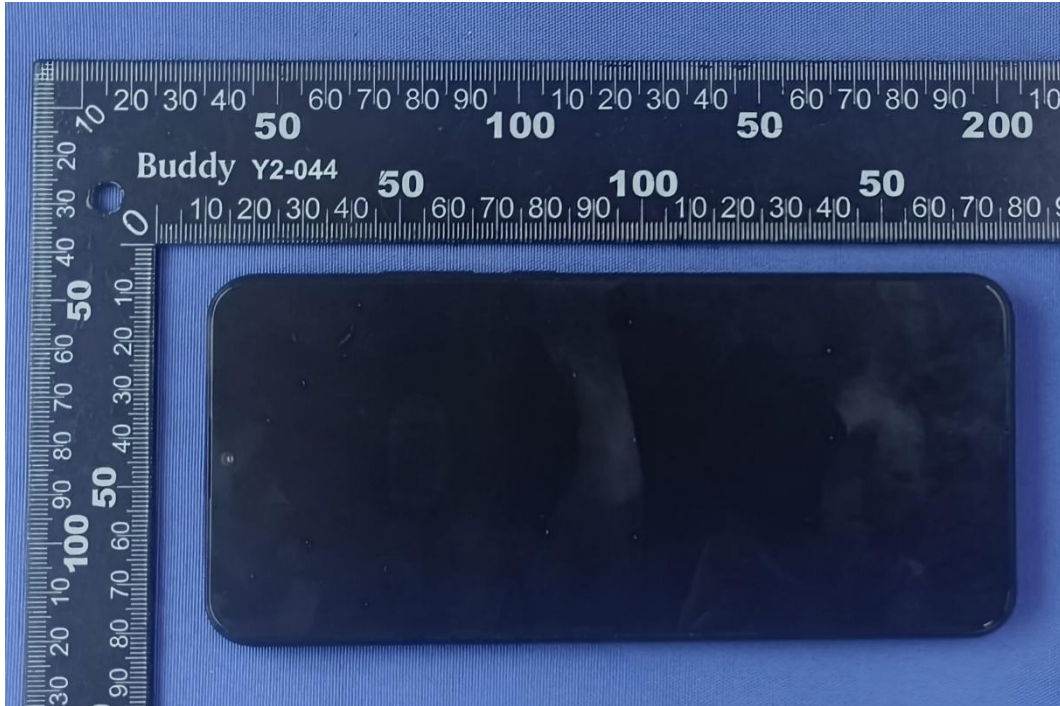

Figure D-1 EUT (Front Side)



Figure D-2 EUT (Rear Side)

ANNEX E Test Setup Diagrams

Test Diagrams

Artificial Ear Type		3.3
Pressure Force [N]		2/8
Center Fork Offset [°]		/
Position		
Xe [°]	Ye [°]	Ze [°]
H	H	+5

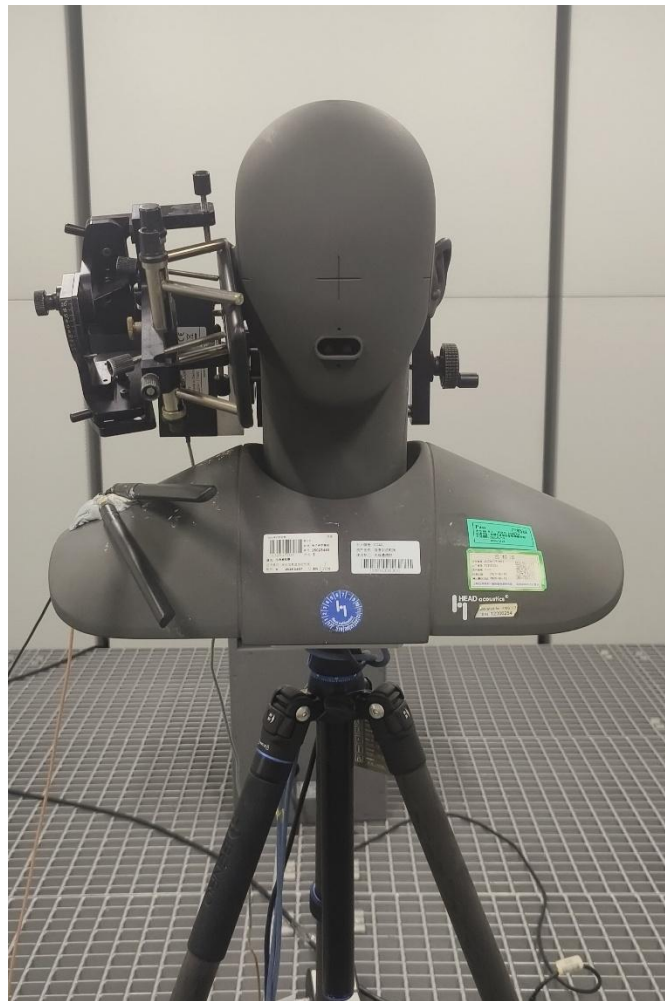

Figure E-1 – Test Layout (Handset)

*****END OF REPORT*****