

20MHz+20MHz Contiguous Chain 0

Spectrum Plot of Measurement Value
QPSK

Channel: 66536

Channel: 66686

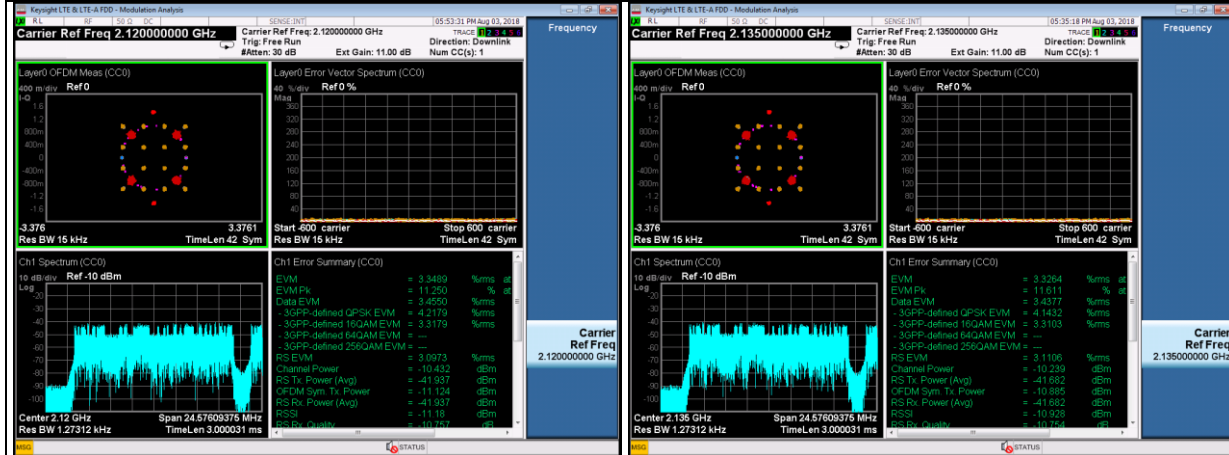

Channel: 66736

Channel: 66836

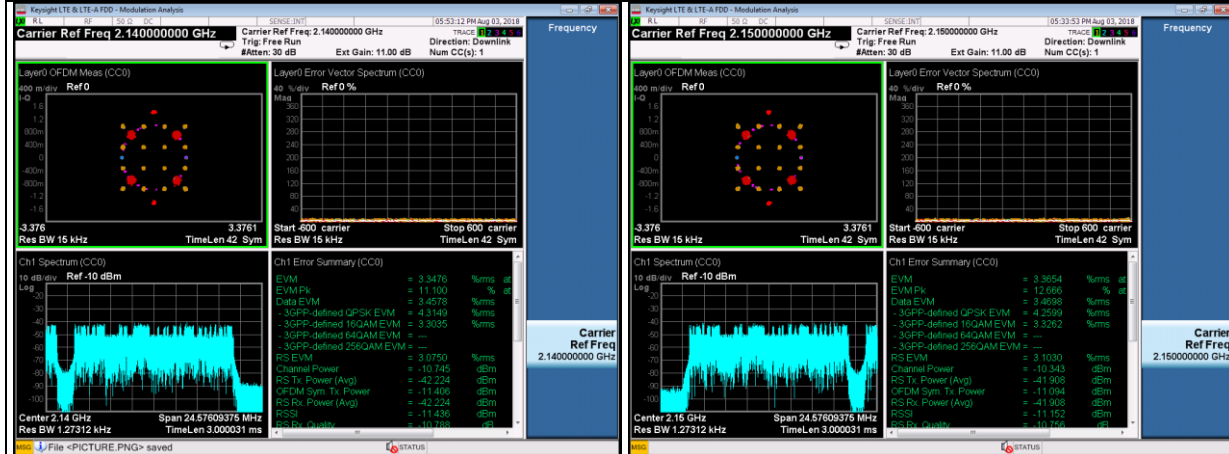

Channel: 66886

Channel: 67036

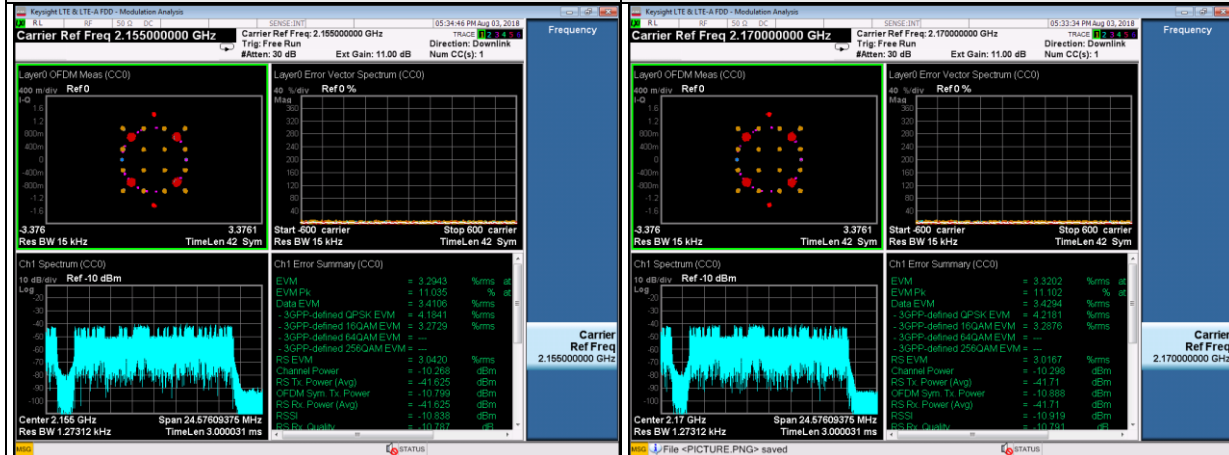

16QAM

Channel: 66536

Channel: 66686

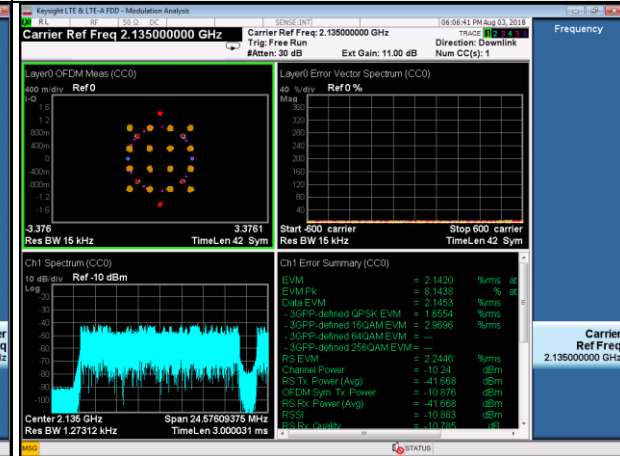
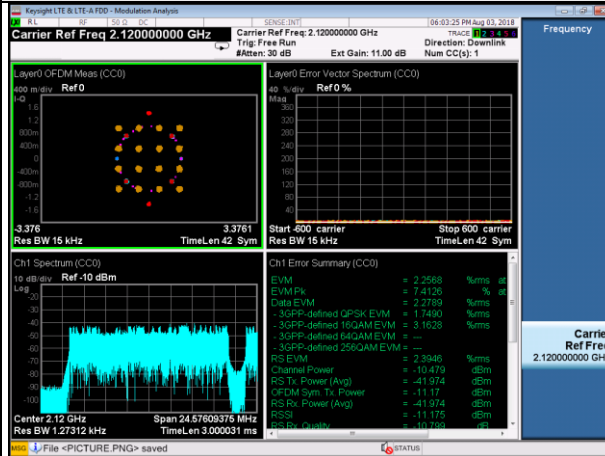

Channel: 66736

Channel: 66836

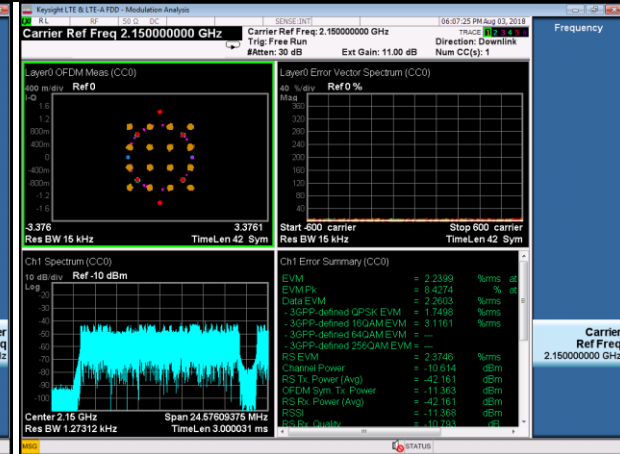
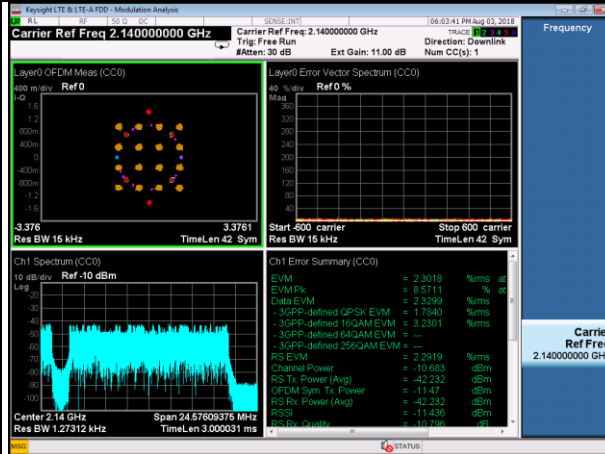

Channel: 66886

Channel: 67036

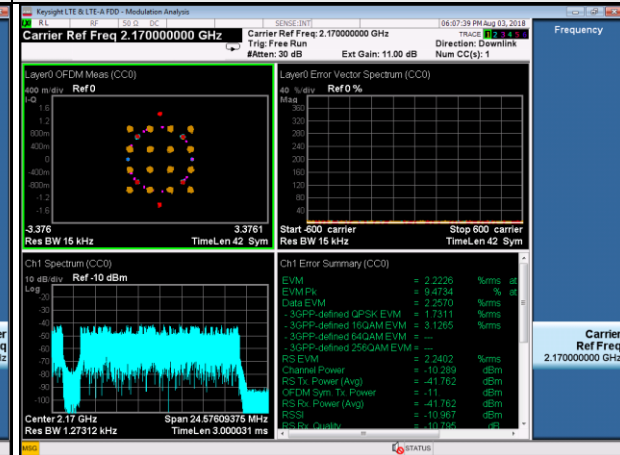
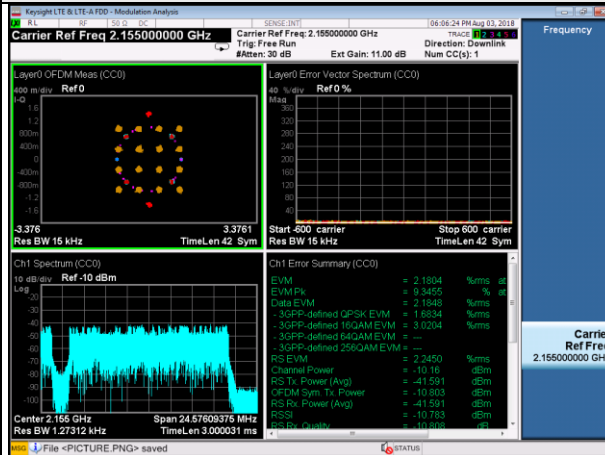

64QAM

Channel: 66536

Channel: 66686

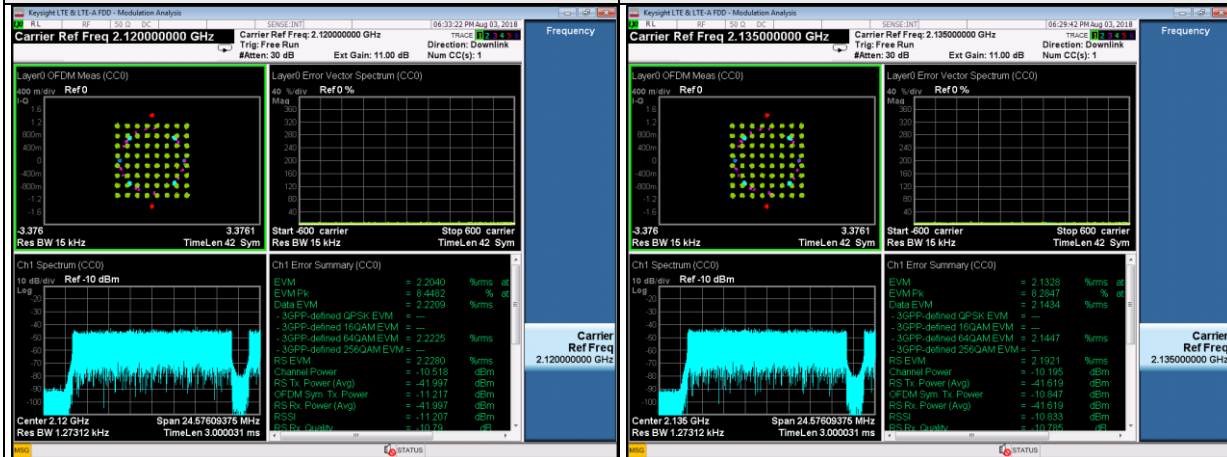

Channel: 66736

Channel: 66836

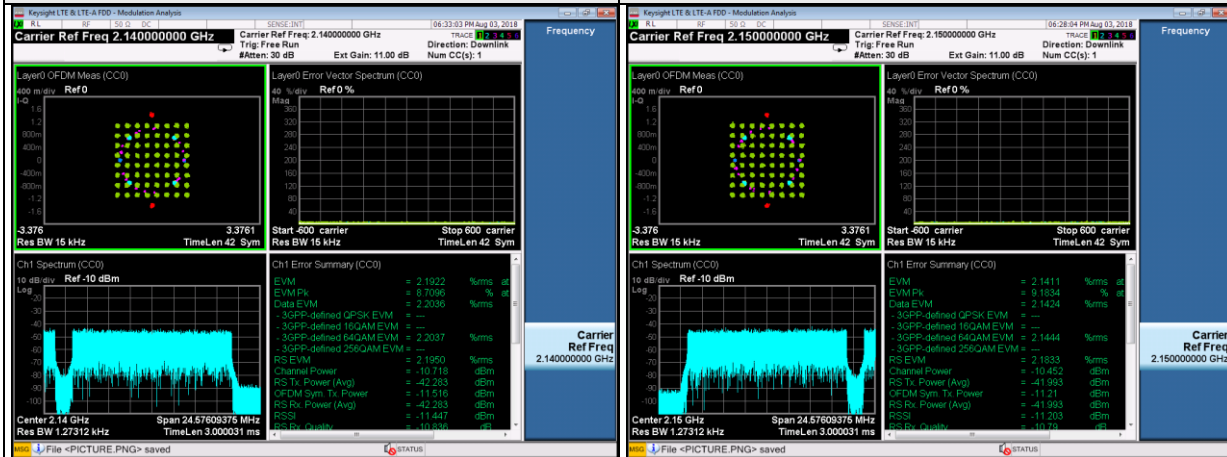

Channel: 66886

Channel: 67036

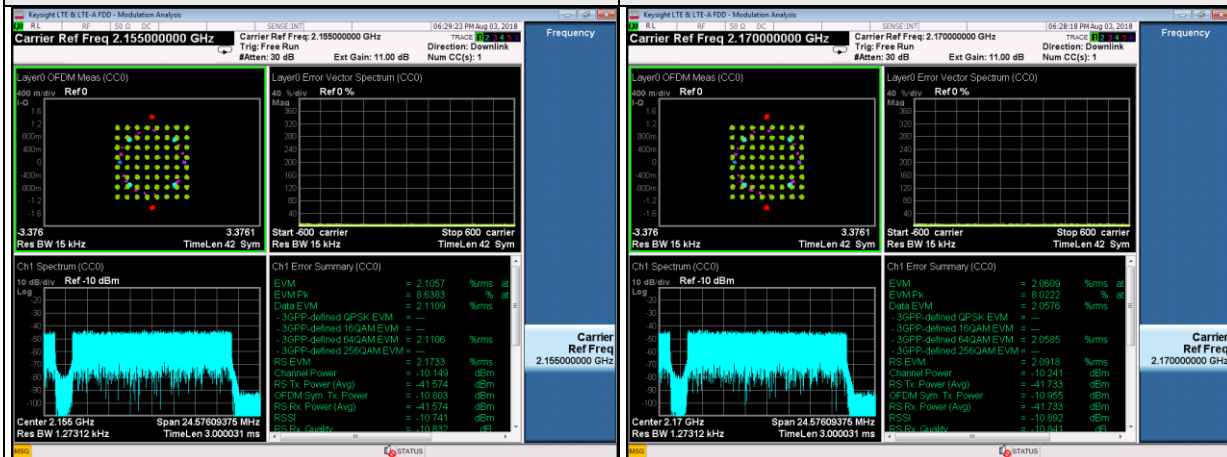

256QAM

Channel: 66536

Channel: 66686

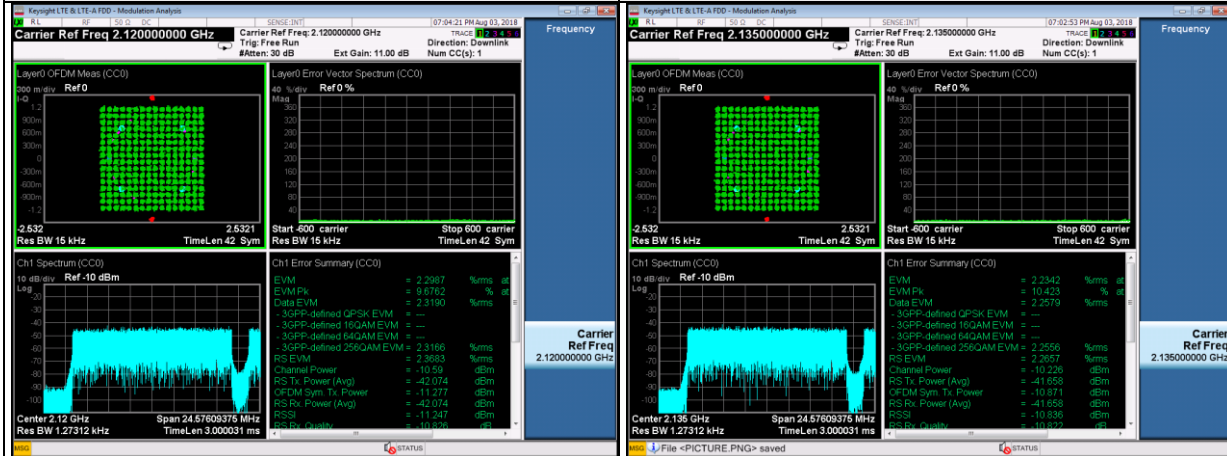

Channel: 66736

Channel: 66836

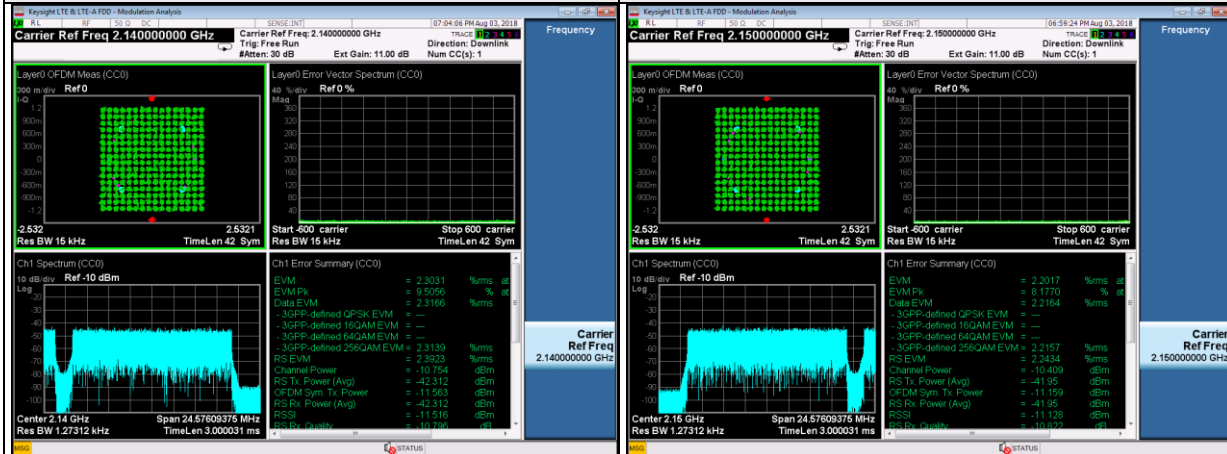

Channel: 66886

Channel: 67036

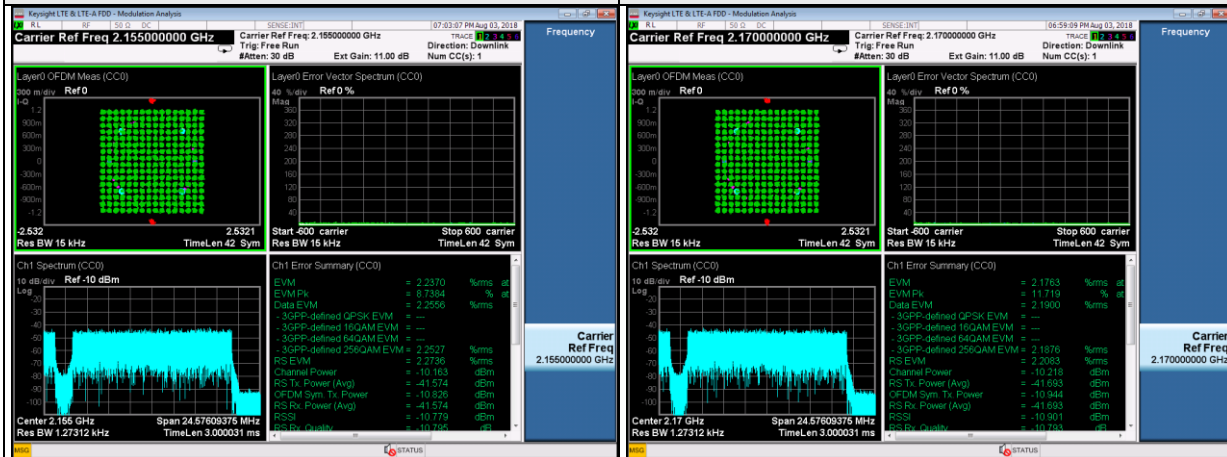

20MHz+20MHz Contiguous Chain 1

Spectrum Plot of Measurement Value QPSK

Channel: 66536

Channel: 66686

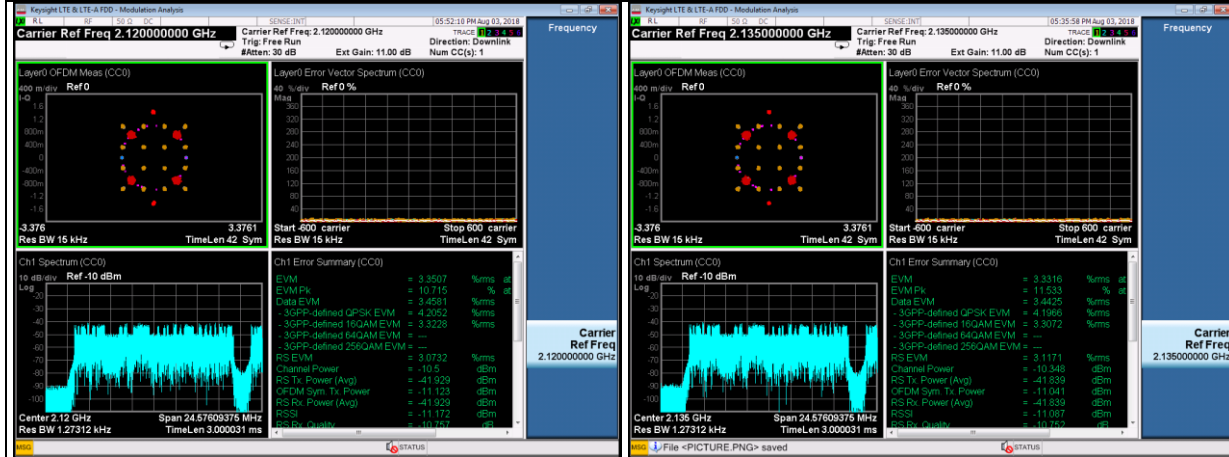

Channel: 66736

Channel: 66836

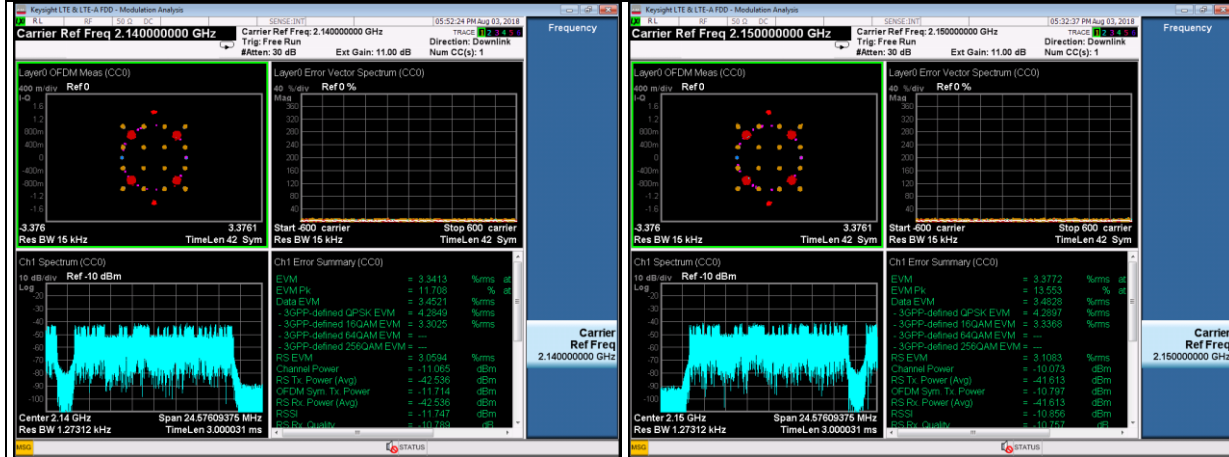

Channel: 66886

Channel: 67036

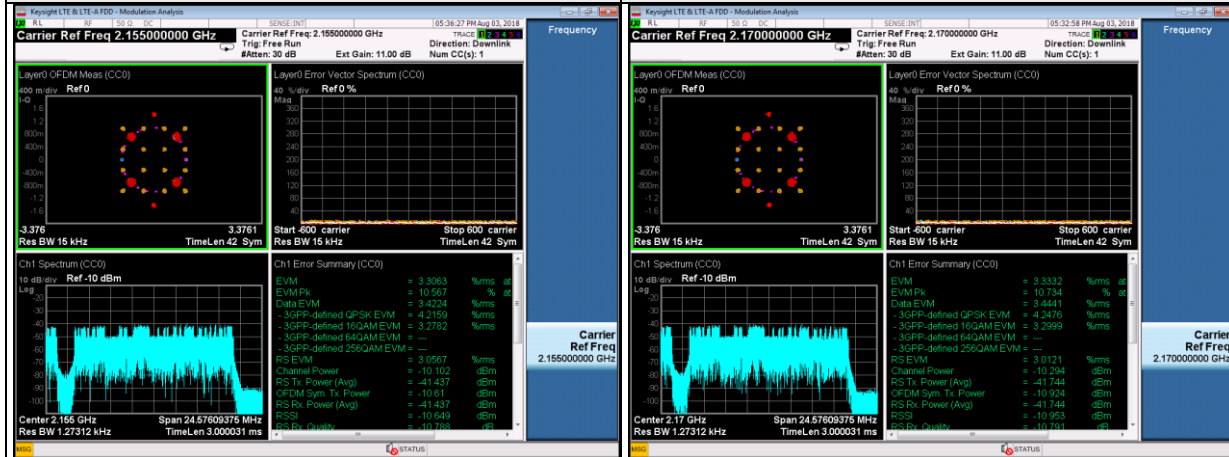

16QAM

Channel: 66536

Channel: 66686

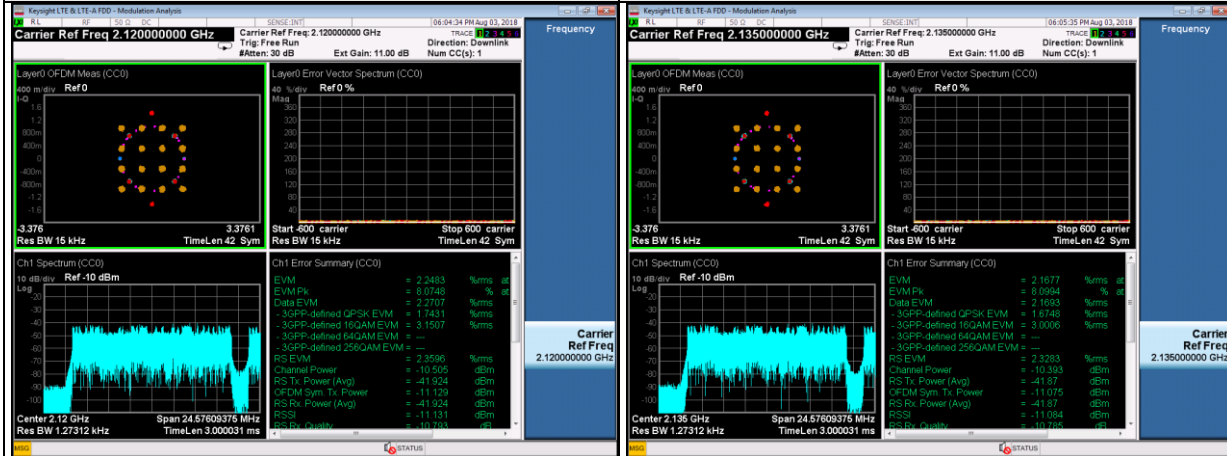

Channel: 66736

Channel: 66836

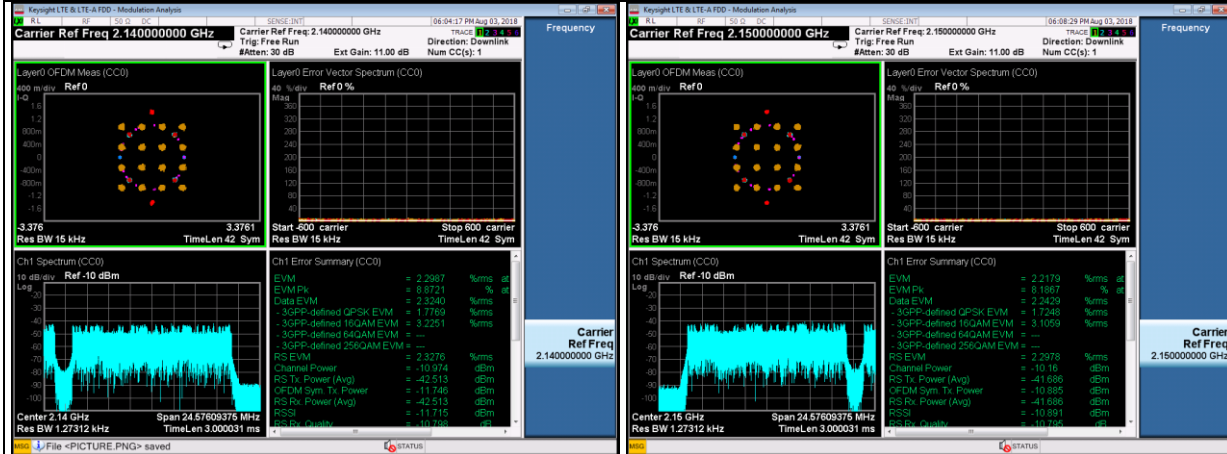

Channel: 66886

Channel: 67036

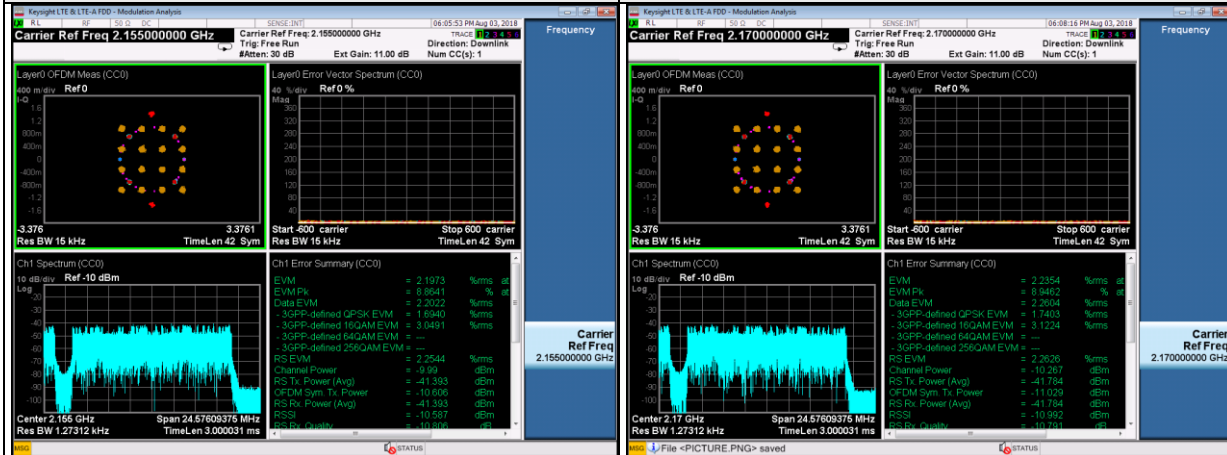

64QAM

Channel: 66536

Channel: 66686

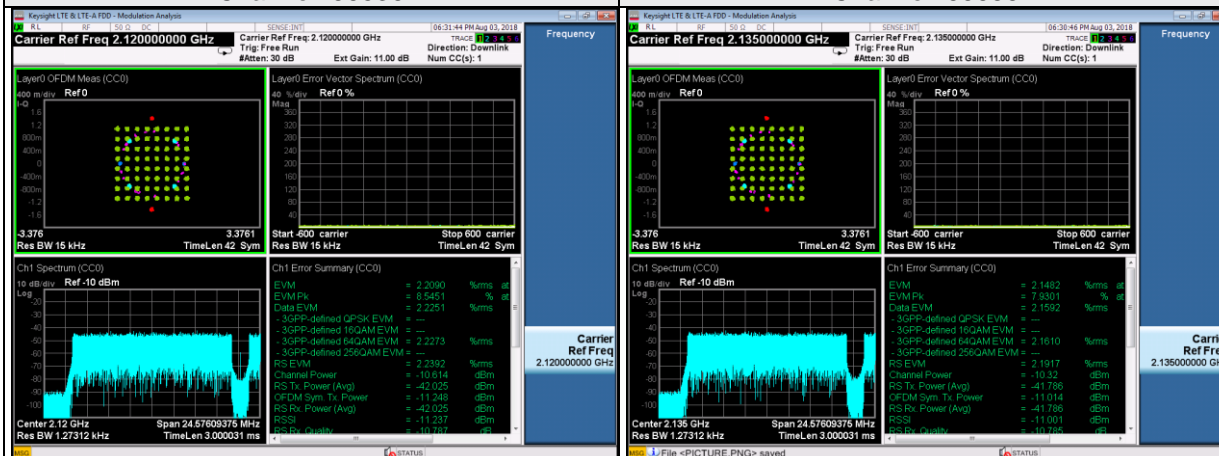

Channel: 66736

Channel: 66836

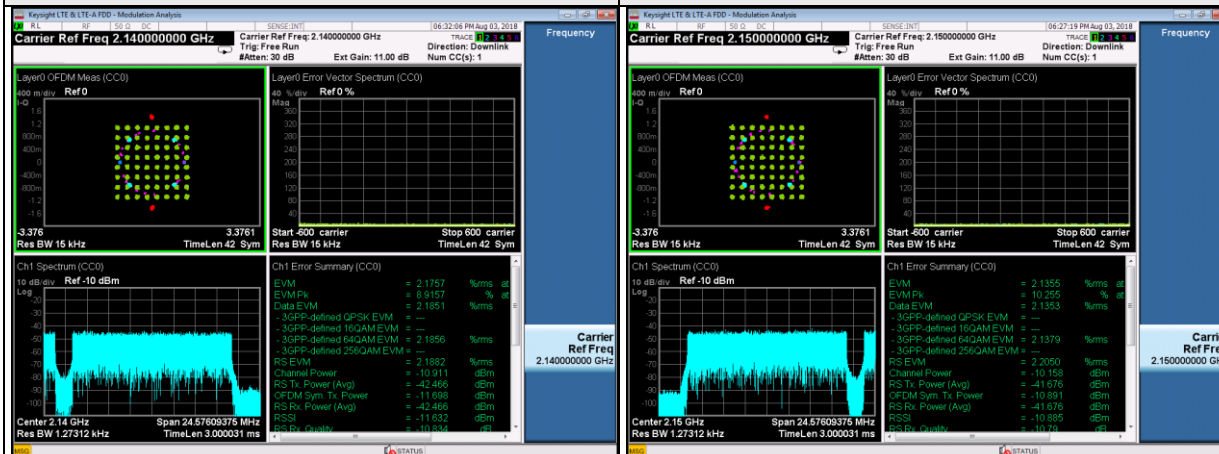

Channel: 66886

Channel: 67036

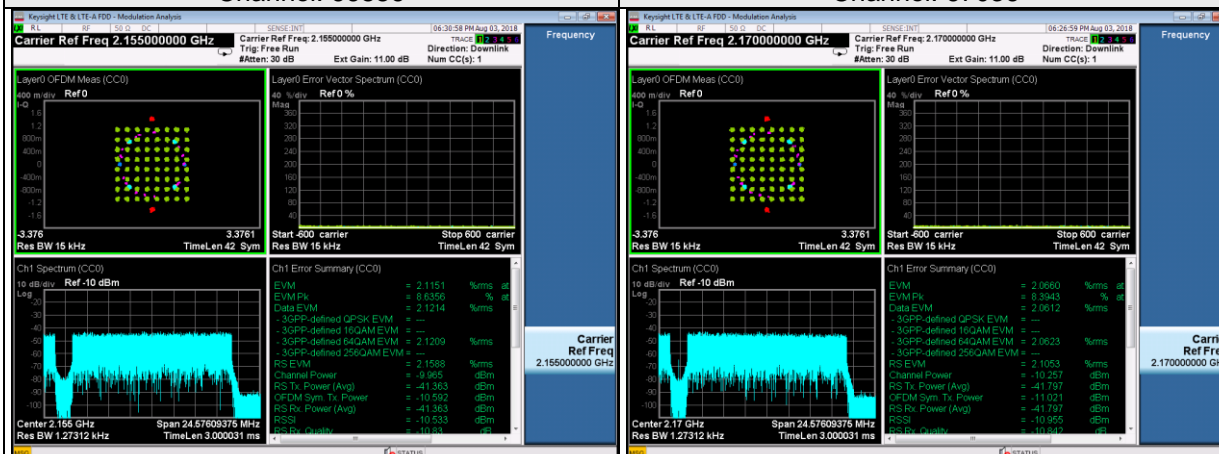

256QAM

Channel: 66536

Channel: 66686

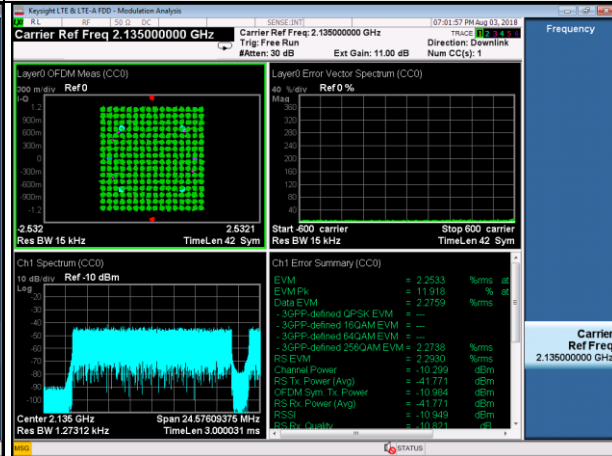
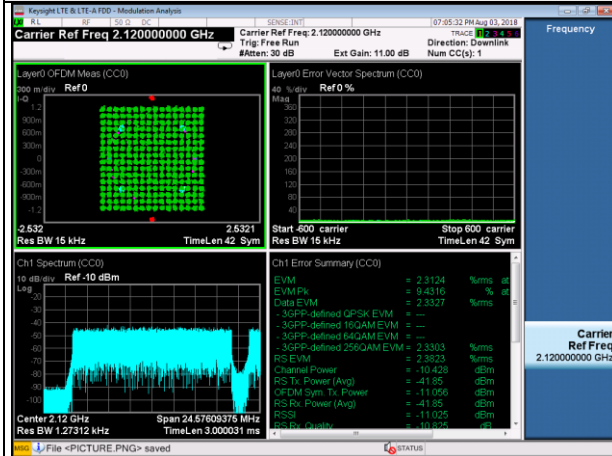

Channel: 66736

Channel: 66836

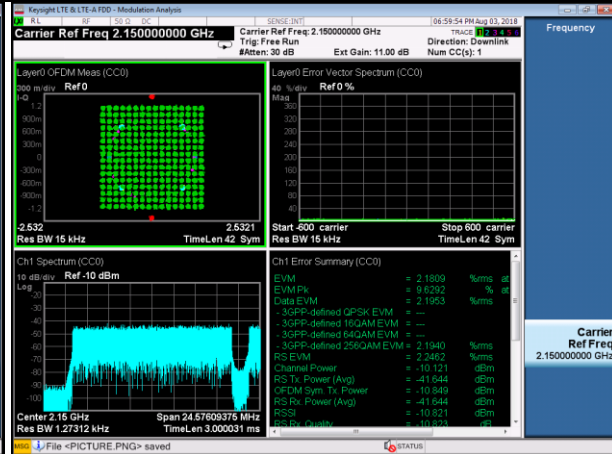
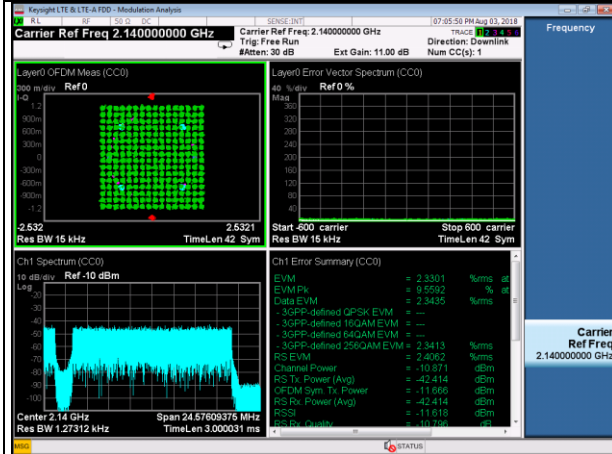

Channel: 66886

Channel: 67036

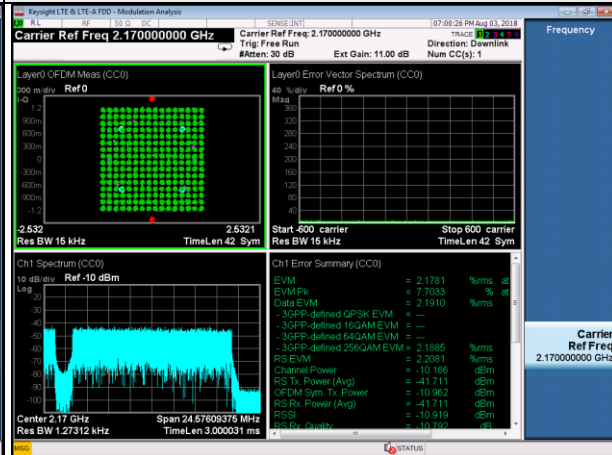
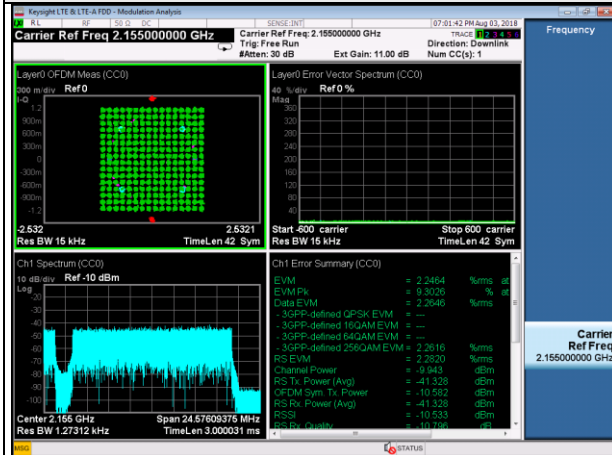

4.3 Frequency Stability Measurement

4.3.1 Limits of Frequency Stability Measurement

According to the FCC part 2.1055 shall be tested the frequency stability. The rule is defined that "The frequency stability shall be sufficient to ensure that the fundamental emission stays within the authorized frequency block." The test extreme voltage is according to the 2.1055(d)(1) Vary primary supply voltage from 85 to 115 percent of the nominal value for other than hand carried battery equipment and the extreme temperature rule is comply with specification of EUT $-30^{\circ}\text{C} \sim 50^{\circ}\text{C}$.

4.3.2 Test Procedure

- Device is placed at the oven room. The oven room could control the temperatures and humidity. Power warm up is at least 15 min and power applied should perform before recording frequency error.
- EUT is connected the external power supply to control the AC input power. The test voltage range is from minimum to maximum working voltage. Each step shall be record the frequency error rate.
- The temperature range step is 10 degrees in this test items. All temperature levels shall be hold the $\pm 0.5^{\circ}\text{C}$ during the measurement testing. The each temperature step shall be at least 0.5 hours, consider the EUT could be test under the stability condition.

NOTE: The frequency error was recorded frequency error from the communication simulator.

4.3.3 Test Setup

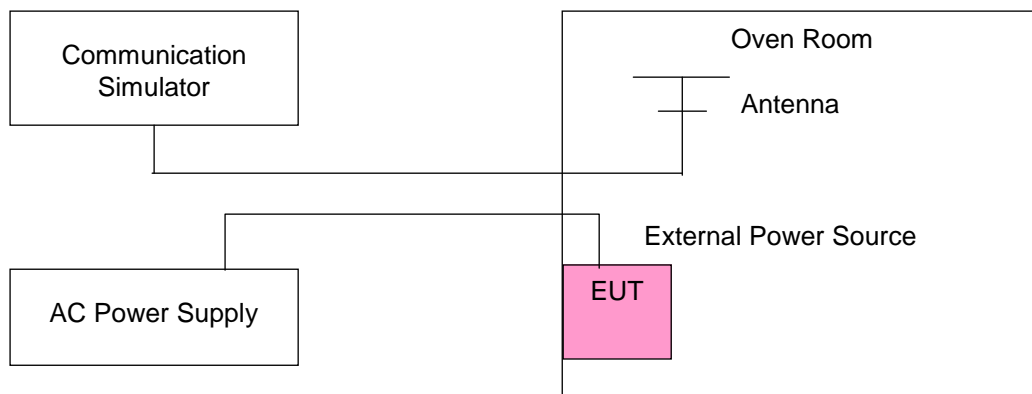

4.3.4 Test Results

Frequency Error vs. Voltage											
Voltage (Volts)	Test result (MHz)								Limit (MHz)		PASS/ FAIL
	10M+15M GAP 15M				10M+15M GAP 20M				Low Edge	High Edge	
	CH 66686 + 66961				CH 66636 + 66961						
	Low		High		Low		High				
	Chain 0	Chain 1	Chain 0	Chain 1	Chain 0	Chain 1	Chain 0	Chain 1			
102	2130.4702	2130.4701	2169.2500	2169.2499	2125.4409	2125.4700	2169.2504	2169.2490	2110	2180	PASS
138	2130.4692	2130.4695	2169.2498	2169.2490	2125.4399	2125.4702	2169.2502	2169.2493	2110	2180	PASS
Voltage (Volts)	Test result (MHz)								Limit (MHz)		PASS/ FAIL
	20M+20M GAP 20M				20M+20M Contiguous				Low Edge	High Edge	
	CH 66536 + 66936		CH 66636 + 67036		CH 66536 + 66736		CH 66836 + 67036				
	Low		High		Low		High				
	Chain 0	Chain 1	Chain 0	Chain 1	Chain 0	Chain 1	Chain 0	Chain 1			
102	2111.0005	2111.0002	2178.9693	2178.9396	2111.1205	2111.0390	2178.7991	2178.8005	2110	2180	PASS
138	2111.0004	2111.0006	2178.9704	2178.9406	2111.1192	2111.0406	2178.8002	2178.7995	2110	2180	PASS

Frequency Error vs. Temperature.

Frequency Error vs. Temperature											
Temp. (°C)	Test result (MHz)								Limit (MHz)		PASS/ FAIL
	10M+15M GAP 15M				10M+15M GAP 20M						
	CH 66686 + 66961				CH 66636 + 66961						
	Low		High		Low		High		Low Edge	High Edge	
	Chain 0	Chain 1	Chain 0	Chain 1	Chain 0	Chain 1	Chain 0	Chain 1			
50	2130.4704	2130.4690	2169.2503	2169.2496	2125.4407	2125.4701	2169.2493	2169.2504	2110	2180	PASS
40	2130.4696	2130.4709	2169.2505	2169.2496	2125.4405	2125.4704	2169.2492	2169.2498	2110	2180	PASS
30	2130.4706	2130.4709	2169.2503	2169.2503	2125.4409	2125.4692	2169.2502	2169.2492	2110	2180	PASS
20	2130.4700	2130.4700	2169.2500	2169.2500	2125.4400	2125.4700	2169.2500	2169.2500	2110	2180	PASS
10	2130.4697	2130.4699	2169.2503	2169.2497	2125.4394	2125.4706	2169.2496	2169.2496	2110	2180	PASS
0	2130.4700	2130.4707	2169.2495	2169.2490	2125.4407	2125.4694	2169.2504	2169.2490	2110	2180	PASS
-10	2130.4709	2130.4706	2169.2506	2169.2500	2125.4396	2125.4702	2169.2505	2169.2503	2110	2180	PASS
-20	2130.4704	2130.4703	2169.2498	2169.2495	2125.4400	2125.4691	2169.2500	2169.2503	2110	2180	PASS
-30	2130.4707	2130.4705	2169.2507	2169.2501	2125.4398	2125.4692	2169.2492	2169.2501	2110	2180	PASS
Temp. (°C)	Test result (MHz)								Limit (MHz)		PASS/ FAIL
	20M+20M GAP 20M				20M+20M Contiguous						
	CH 66536 + 66936		CH 66636 + 67036		CH 66536 + 66736		CH 66836 + 67036				
	Low		High		Low		High		Low Edge	High Edge	
	Chain 0	Chain 1	Chain 0	Chain 1	Chain 0	Chain 1	Chain 0	Chain 1			
50	2110.9994	2110.9995	2178.9699	2178.9395	2111.1193	2111.0409	2178.7995	2178.7992	2110	2180	PASS
40	2110.9990	2110.9992	2178.9691	2178.9406	2111.1209	2111.0393	2178.7993	2178.7997	2110	2180	PASS
30	2111.0008	2111.0004	2178.9709	2178.9409	2111.1196	2111.0394	2178.7991	2178.8006	2110	2180	PASS
20	2111.0000	2111.0000	2178.9700	2178.9400	2111.1200	2111.0400	2178.8000	2178.8000	2110	2180	PASS
10	2111.0009	2111.0000	2178.9696	2178.9399	2111.1201	2111.0400	2178.8006	2178.7995	2110	2180	PASS
0	2111.0007	2111.0008	2178.9702	2178.9391	2111.1199	2111.0395	2178.7993	2178.8009	2110	2180	PASS
-10	2111.0004	2111.0002	2178.9707	2178.9392	2111.1190	2111.0402	2178.7991	2178.8002	2110	2180	PASS
-20	2111.0009	2110.9993	2178.9697	2178.9403	2111.1200	2111.0394	2178.8001	2178.7994	2110	2180	PASS
-30	2110.9996	2110.9997	2178.9704	2178.9394	2111.1204	2111.0401	2178.7997	2178.7992	2110	2180	PASS