



## MEASUREMENT REPORT

### FCC PART 15.247 Bluetooth

---

**FCC ID:** 2ACZWBT004

**APPLICANT:** Shenzhen Zhonghenghua Technology CO.,Ltd

**Application Type:** Certification

**Product:** Wireless Selfie Sticks

**Model No.:** BT-004, BT-005, BT-001, BT-002, BT-003, BT-006,  
BT-007, BT-008, BT-009, BT-010, BT-011

**FCC Classification:** FCC Part 15 Spread Spectrum Transmitter(DSS)

**FCC Rule Part(s):** Part 15.247

**Test Procedure(s):** ANSI C63.10-2009, DA 00-705

**Test Date:** Nov. 10 ~ 14, 2014

Reviewed By : Robin Wu  
( Robin Wu )

Approved By : Marlin Chen  
( Marlin Chen )

The test results relate only to the samples tested.

This equipment has been shown to be capable of compliance with the applicable technical standards as indicated in the measurement report and was tested in accordance with the measurement procedures specified in ANSI C63.10-2009 and DA 00-705. Test results reported herein relate only to the item(s) tested.

The test report shall not be reproduced except in full without the written approval of MRT Technology (Suzhou) Co., Ltd.

## Revision History

Report No.	Version	Description	Issue Date
1411RSU01301	Rev. 01	Initial report	11-15-2014
1411RSU01301	Rev. 02	Correct the test frequency	11-18-2014

## CONTENTS

Description	Page
<b>1. INTRODUCTION .....</b>	<b>7</b>
1.1. Scope .....	7
1.2. MRT Test Location .....	7
<b>2. PRODUCT INFORMATION .....</b>	<b>8</b>
2.1. Equipment Description.....	8
2.2. Frequency / Channel Operation.....	9
2.3. Pseudorandom Frequency Hopping Sequence.....	10
2.4. Device Capabilities .....	10
2.5. Test Configuration .....	10
2.6. Test Software .....	10
2.7. Description of Support Units .....	11
2.8. EMI Suppression Device(s)/Modifications.....	11
2.9. Labeling Requirements.....	11
<b>3. DESCRIPTION OF TEST .....</b>	<b>12</b>
3.1. Evaluation Procedure .....	12
3.2. AC Line Conducted Emissions .....	12
3.3. Radiated Emissions .....	13
<b>4. ANTENNA REQUIREMENTS.....</b>	<b>14</b>
<b>5. TEST EQUIPMENT CALIBRATION DATE.....</b>	<b>15</b>
<b>6. MEASUREMENT UNCERTAINTY.....</b>	<b>16</b>
<b>7. TEST RESULT .....</b>	<b>17</b>
7.1. Summary .....	17
7.2. 20dB Bandwidth Measurement.....	18
7.2.1. Test Limit .....	18
7.2.2. Test Procedure used.....	18
7.2.3. Test Setting.....	18
7.2.4. Test Setup.....	19
7.2.5. Test Result.....	20
7.3. Output Power Measurement.....	23
7.3.1. Test Limit .....	23
7.3.2. Test Procedure Used .....	23
7.3.3. Test Setting.....	23
7.3.4. Test Setup.....	24

7.3.5.	Test Result.....	25
7.4.	Carrier Frequency Separation Measurement .....	28
7.4.1.	Test Limit .....	28
7.4.2.	Test Procedure Used .....	28
7.4.3.	Test Setting.....	28
7.4.4.	Test Setup.....	28
7.4.5.	Test Result.....	29
7.5.	Number of Hopping Channels Measurement .....	32
7.5.1.	Test Limit .....	32
7.5.2.	Test Procedure Used .....	32
7.5.3.	Test Setting.....	32
7.5.4.	Test Setup.....	32
7.5.5.	Test Result.....	33
7.6.	Time of Occupancy Measurement .....	36
7.6.1.	Test Limit .....	36
7.6.2.	Test Procedure Used .....	36
7.6.3.	Test Setting.....	36
7.6.4.	Test Setup.....	37
7.6.5.	Test Result.....	38
7.7.	Band-edge Compliance Measurement.....	40
7.7.1.	Test Limit .....	40
7.7.2.	Test Procedure Used .....	40
7.7.3.	Test Setting.....	40
7.7.4.	Test Setup.....	41
7.7.5.	Test Result.....	42
7.8.	Conducted Spurious Emissions Measurement.....	45
7.8.1.	Test Limit .....	45
7.8.2.	Test Procedure Used .....	45
7.8.3.	Test Setting.....	45
7.8.4.	Test Setup.....	46
7.8.5.	Test Result.....	47
7.9.	Radiated Spurious Emission Measurement .....	50
7.9.1.	Test Limit .....	50
7.9.2.	Test Procedure Used .....	50
7.9.3.	Test Setting.....	50
7.9.4.	Test Setup.....	52
7.9.5.	Test Result.....	54
7.10.	Radiated Restricted Band Edge Measurement .....	61

7.10.1. Test Result..... 61

7.11. AC Conducted Emissions Measurement..... 69

7.11.1. Test Limit ..... 69

7.11.2. Test Setup..... 69

7.11.3. Test Result..... 70

**8. CONCLUSION..... 72**

## §2.1033 General Information

<b>Applicant:</b>	Shenzhen Zhonghenghua Technology CO.,Ltd
<b>Applicant Address:</b>	4/F, Fan'en Building, Nankeng Village, Bantian, Longgang District, Shenzhen
<b>Manufacturer:</b>	Shenzhen Zhonghenghua Technology CO.,Ltd
<b>Manufacturer Address:</b>	4/F, Fan'en Building, Nankeng Village, Bantian, Longgang District, Shenzhen
<b>Test Site:</b>	MRT Technology (Suzhou) Co., Ltd
<b>Test Site Address:</b>	D8 Building, No.2 Tian'edang Rd., Wuzhong Economic Development Zone, Suzhou, China
<b>MRT Registration No.:</b>	809388
<b>FCC Rule Part(s):</b>	Part 15.247
<b>Model No.</b>	BT-004, BT-005, BT-001, BT-002, BT-003, BT-006, BT-007, BT-008, BT-009, BT-010, BT-011
<b>FCC ID:</b>	2ACZWBT004
<b>Test Device Serial No.:</b>	N/A <input type="checkbox"/> Production <input checked="" type="checkbox"/> Pre-Production <input type="checkbox"/> Engineering
<b>FCC Classification:</b>	FCC Part 15 Spread Spectrum Transmitter (DSS)
<b>Method/System:</b>	Frequency Hopping Spread Spectrum (FHSS)
<b>Date(s) of Test:</b>	Nov. 10 ~ 14, 2014
<b>Test Report S/N:</b>	1411RSU01301

### Test Facility / Accreditations

Measurements were performed at MRT Laboratory located in Tian'edang Rd., Suzhou, China.

- MRT facility is a FCC registered (MRT Reg. No. 809388) test facility with the site description report on file and has met all the requirements specified in Section 2.948 of the FCC Rules.
- MRT facility is an IC registered (MRT Reg. No. 11384A-1) test laboratory with the site description on file at Industry Canada.
- MRT facility is a VCCI registered (R-4179, G-814, C-4664, T-2206) test laboratory with the site description on file at VCCI Council.
- MRT Lab is accredited to ISO 17025 by the American Association for Laboratory Accreditation (A2LA) under the American Association for Laboratory Accreditation Program (A2LA Cert. No. 3628.01) in EMC, Telecommunications and Radio testing for FCC, Industry Canada, EU and TELEC Rules.

# 1. INTRODUCTION

## 1.1. Scope

Measurement and determination of electromagnetic emissions (EMC) of radio frequency devices including intentional and/or unintentional radiators for compliance with the technical rules and regulations of the Federal Communications Commission and the Industry Canada Certification and Engineering Bureau.

## 1.2. MRT Test Location

The map below shows the location of the MRT LABORATORY, its proximity to the Taihu Lake. These measurement tests were conducted at the MRT Technology (Suzhou) Co., Ltd. Facility located at D8 Building, No.2 Tian'edang Rd., Wuzhong Economic Development Zone, Suzhou, China. The detailed description of the measurement facility was found to be in compliance with the requirements of § 2.948 according to ANSI C63.4-2009 on September 30, 2013.



## 2. PRODUCT INFORMATION

### 2.1. Equipment Description

Product Name	Wireless Selfie Sticks
Model No.	BT-004, BT-005, BT-001, BT-002, BT-003, BT-006, BT-007, BT-008, BT-009, BT-010, BT-011
<b>Bluetooth (1x, EDR)</b>	
Bluetooth Frequency	2402~2480MHz
Bluetooth Version	V3.0 + EDR
Type of modulation	FHSS
Data Rate	1Mbps(GFSK), 2Mbps(Pi/4 DQPSK), 3Mbps (8DPSK)
Antenna Type	Internal
Antenna Gain	2.3dBi

The equipment under test (EUT) is the **Wireless Selfie Sticks FCC ID: 2ACZWBT004**. The test data contained in this report pertains only to the emissions due to the EUT's Bluetooth transmitter.

- 15.247(g): In accordance with the Bluetooth Industry Standard, the system is designed to comply with all of the regulations in Section 15.247 when the transmitter is presented with a continuous data (or information) system.
- 15.247(h): In accordance with the Bluetooth Industry Standard, the system does not coordinate its channels selection/ hopping sequence with other frequency hopping systems for the express purpose of avoiding the simultaneous occupancy of individual hopping frequencies by multiple transmitters.
- 15.247(h): The EUT employs Adaptive Frequency Hopping (AFH) which identifies sources of interference namely devices operating in 802.11 WLAN and excludes them from the list of available channels. The process of re-mapping reduces the number of test channels from 79 channels to a minimum number of 20 channels.



## 2.2. Frequency / Channel Operation

Channel	Frequency	Channel	Frequency	Channel	Frequency
00	2402 MHz	01	2403 MHz	02	2404 MHz
03	2405 MHz	04	2406 MHz	05	2407 MHz
06	2408 MHz	07	2409 MHz	08	2410 MHz
09	2411 MHz	10	2412 MHz	11	2413 MHz
12	2414 MHz	13	2415 MHz	14	2416 MHz
15	2417 MHz	16	2418 MHz	17	2419 MHz
18	2420 MHz	19	2421 MHz	20	2422 MHz
21	2423 MHz	22	2424 MHz	23	2425 MHz
24	2426 MHz	25	2427 MHz	26	2428 MHz
27	2429 MHz	28	2430 MHz	29	2431 MHz
30	2432 MHz	31	2433 MHz	32	2434 MHz
33	2435 MHz	34	2436 MHz	35	2437 MHz
36	2438 MHz	37	2439 MHz	38	2440 MHz
39	2441 MHz	40	2442 MHz	41	2443 MHz
42	2444 MHz	43	2445 MHz	44	2446 MHz
45	2447 MHz	46	2448 MHz	47	2449 MHz
48	2450 MHz	49	2451 MHz	50	2452 MHz
51	2453 MHz	52	2454 MHz	53	2455 MHz
54	2456 MHz	55	2457 MHz	56	2458 MHz
57	2459 MHz	58	2460 MHz	59	2461 MHz
60	2462 MHz	61	2463 MHz	62	2464 MHz
63	2465 MHz	64	2466 MHz	65	2467 MHz
66	2468 MHz	67	2469 MHz	68	2470 MHz
69	2471 MHz	70	2472 MHz	71	2473 MHz
72	2474 MHz	73	2475 MHz	74	2476 MHz
75	2477 MHz	76	2478 MHz	77	2479 MHz
78	2480 MHz	N/A	N/A	N/A	N/A

### 2.3. Pseudorandom Frequency Hopping Sequence

The pseudorandom sequence may be generated in a nine-stage shift register whose 5th and 9<sup>th</sup> stage outputs are added in a modulo-two addition stage. And the result is fed back to the input of the first stage. The sequence begins with the first ONE of 9 consecutive ONES; i.e. the shift register is initialized with nine ones.

- Number of shift register stages: 9
- Length of pseudo-random sequence:  $2^9 - 1 = 511$  bits
- Longest sequence of zeros: 8 (non-inverted signal)

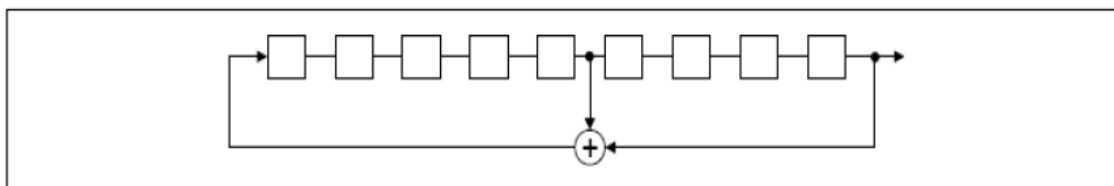

Linear Feedback Shift Register for Generation of the PRBS sequence

An example of Pseudorandom Frequency Hopping Sequence as follow:

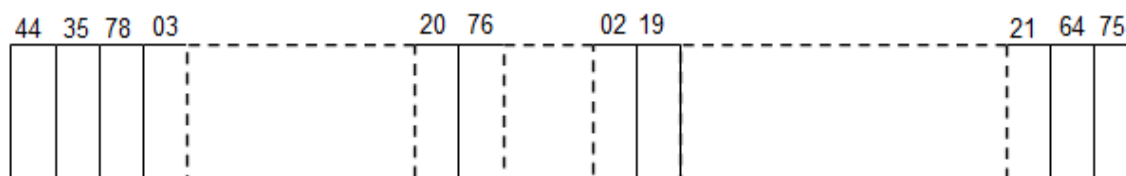

Each frequency used equally on the average by each transmitter.

The system receivers have input bandwidths that match the hopping channel bandwidths of their Corresponding transmitters and shift frequencies in synchronization with the transmitted signals.

### 2.4. Device Capabilities

Bluetooth (1x, EDR)

### 2.5. Test Configuration

The **Wireless Selfie Sticks FCC ID: 2ACZWBT004** was tested per the guidance of ANSI C63.10-2009 and DA 00-705. ANSI C63.10-2009 was used to reference the appropriate EUT setup for radiated spurious emissions testing and AC line conducted testing.

### 2.6. Test Software

The test utility software used during testing was engineering order by applicant.

## 2.7. Description of Support Units

The EUT has been tested with associated equipment below:

Description	Manufacturer	Model No.
Adapter	Supply by MRT	HSU50600F

## 2.8. EMI Suppression Device(s)/Modifications

No EMI suppression device(s) were added and/or no modifications were made during testing.

## 2.9. Labeling Requirements

Per 2.1074 & 15.19; Docket 95-19

The label shall be permanently affixed at a conspicuous location on the device; instruction manual or pamphlet supplied to the user and be readily visible to the purchaser at the time of purchase.

However, when the device is so small wherein placement of the label with specified statement is not practical, only the trade name and FCC ID must be displayed on the device per Section 15.19(a)(5).

Please see attachment for FCC ID label and label location.

### 3. DESCRIPTION OF TEST

#### 3.1. Evaluation Procedure

The measurement procedures described in the American National Standard for Testing Unlicensed Wireless Devices (ANSI C63.10-2009), and the “Filing and Measurement Guidelines for Frequency Hopping Spread Spectrum Systems” (DA 00-705) were used in the measurement of the **Wireless Selfie Sticks FCC ID: 2ACZWBT004**.

**Deviation from measurement procedure.....None**

#### 3.2. AC Line Conducted Emissions

The line-conducted facility is located inside an 8'x4'x4' shielded enclosure. A 1m x 2m wooden table 80cm high is placed 40cm away from the vertical wall and 80cm away from the sidewall of the shielded room. Two 10kHz-30MHz, 50Ω/50uH Line-Impedance Stabilization Networks (LISNs) are bonded to the shielded room floor. Power to the LISNs is filtered by external high-current high-insertion loss power line filters. These filters attenuate ambient signal noise from entering the measurement lines. These filters are also bonded to the shielded enclosure.

The EUT is powered from one LISN and the support equipment is powered from the second LISN. All interconnecting cables more than 1 meter were shortened to a 1 meter length by non-inductive bundling (serpentine fashion) and draped over the back edge of the test table. All cables were at least 40cm above the horizontal reference ground-plane. Power cables for support equipment were routed down to the second LISN while ensuring that that cables were not draped over the second LISN.

Sufficient time for the EUT, support equipment, and test equipment was allowed in order for them to warm up to their normal operating condition. The RF output of the LISN was connected to the receiver and exploratory measurements were made to determine the frequencies producing the maximum emission from the EUT. The receiver was scanned from 150kHz to 30MHz. The detector function was set to peak mode for exploratory measurements while the bandwidth of the analyzer was set to 9kHz. The EUT, support equipment, and interconnecting cables were arranged and manipulated to maximize each emission. Each emission was also maximized by varying: power lines, the mode of operation or data exchange speed, or support equipment whichever determined the worst-case emission. Once the worst case emissions have been identified, the one EUT cable configuration/arrangement and mode of operation that produced these emissions were used for final measurements on the same test site. The analyzer is set to CISPR quasi-peak and average detectors with a 9kHz resolution bandwidth for final measurements.

An extension cord was used to connect to a single LISN which powered by EUT. The extension cord was calibrated with LISN, the impedance and insertion loss are compliance with the requirements as stated in ANSI C63.10-2009 at Clause 4.3.

Line conducted emissions test results are shown in Section 7.11.

### 3.3. Radiated Emissions

The radiated test facilities consisted of an indoor 3 meter semi-anechoic chamber used for final measurements and exploratory measurements, when necessary. The measurement area is contained within the semi-anechoic chamber which is shielded from any ambient interference. For measurements above 1GHz absorbers are arranged on the floor between the turn table and the antenna mast in such a way so as to maximize the reduction of reflections. For measurements below 1GHz, the absorbers are removed. An MF Model 210SS turntable is used for radiated measurement. It is a continuously rotatable, remote controlled, metallic turntable and 2 meters (6.56 ft.) in diameter. The turn table is flush with the raised floor of the chamber in order to maintain its function as a ground plane. An 80cm high PVC support structure is placed on top of the turntable.

For all measurements, the spectrum was scanned through all EUT azimuths and from 1 to 4 meter receive antenna height using a broadband antenna from 30MHz up to the upper frequency shown in 15.33(b)(1) depending on the highest frequency generated or used in the device or on which the device operates or tunes. For frequencies above 1GHz, linearly polarized double ridge horn antennas were used. For frequencies below 30MHz, a calibrated loop antenna was used. When exploratory measurements were necessary, they were performed at 1 meter test distance inside the semi-anechoic chamber using broadband antennas, broadband amplifiers, and spectrum analyzers to determine the frequencies and modes producing the maximum emissions. Sufficient time for the EUT, support equipment, and test equipment was allowed in order for them to warm up to their normal operating condition. The test set-up was placed on top of the 0.8 meter high, 1 x 1.5 meter table. The EUT, support equipment, and interconnecting cables were arranged and manipulated to maximize each emission. Appropriate precaution was taken to ensure that all emissions from the EUT were maximized and investigated. The system configuration, clock speed, mode of operation or video resolution, if applicable, turntable azimuth, and receive antenna height was noted for each frequency found.

Final measurements were made in the semi-anechoic chamber using calibrated, linearly polarized broadband and horn antennas. The test setup was configured to the setup that produced the worst case emissions. The spectrum analyzer was set to investigate all frequencies required for testing to compare the highest radiated disturbances with respect to the specified limits. The turntable containing the EUT was rotated through 360 degrees and the height of the receive antenna was varied 1 to 4 meters and stopped at the azimuth and height producing the maximum emission. Each emission was maximized by changing the orientation of the EUT through three orthogonal planes and changing the polarity of the receive antenna, whichever produced the worst-case emissions. According to 3dB Beamwidth of horn antenna, the horn antenna should be always directed to the EUT when rising height.

## 4. ANTENNA REQUIREMENTS

### Excerpt from §15.203 of the FCC Rules/Regulations:

“An intentional radiator antenna shall be designed to ensure that no antenna other than that furnished by the responsible party can be used with the device. The use of a permanently attached antenna or of an antenna that uses a unique coupling to the intentional radiator shall be considered sufficient to comply with the provisions of this section.”

- The antenna of the Wireless Selfie Sticks is **permanently attached**.
- There are no provisions for connection to an external antenna.

### Conclusion:

The **Wireless Selfie Sticks FCC ID: 2ACZWBT004** unit complies with the requirement of §15.203.

## 5. TEST EQUIPMENT CALIBRATION DATE

### Conducted Emissions

Instrument	Manufacturer	Type No.	Serial No.	Cali. Interval	Cali. Due Date
EMI Test Receiver	R&S	ESR7	101209	1 year	2015/11/07
Two-Line V-Network	R&S	ENV216	101683	1 year	2015/11/07
Two-Line V-Network	R&S	ENV216	101684	1 year	2015/11/07
Temperature/ Meter Humidity	Anymetre	TH101B	SR2-01	1 year	2015/11/15

### Radiated Emission

Instrument	Manufacturer	Type No.	Serial No.	Cali. Interval	Cali. Due Date
Spectrum Analyzer	Agilent	N9010A	MY5144016A	1 year	2015/01/04
Preamplifier	MRT	AP01G18	1310002	1 year	2015/10/06
Loop Antenna	Schwarzbeck	FMZB1519	1519-041	1 year	2015/11/08
TRILOG Antenna	Schwarzbeck	VULB9162	9162-047	1 year	2015/11/08
Broad-Band Horn Antenna	Schwarzbeck	BBHA9120D	9120D-1167	1 year	2015/11/08
Broadband Horn Antenna	Schwarzbeck	BBHA9170	9170-549	1 year	2014/12/11
Temperature/Humidity Meter	Anymetre	TH101B	AC1-01	1 year	2015/11/15

### Conducted Test Equipment

Instrument	Manufacturer	Type No.	Serial No.	Cali. Interval	Cali. Due Date
Spectrum Analyzer	Agilent	N9010A	MY5144016A	1 year	2015/01/04
Power Sensor	Agilent	U2021XA	MY52450003	1 year	2014/12/14
Temperature/Humidity Meter	Anymetre	TH101B	TR3-01	1 year	2015/11/15

## 6. MEASUREMENT UNCERTAINTY

Where relevant, the following test uncertainty levels have been estimated for tests performed on the EUT as specified in CISPR 16-4-2. This uncertainty represents an expanded uncertainty expressed at approximately the 95% confidence level using a coverage factor of  $k = 2$ .

<b>AC Conducted Emission Measurement</b>
Measuring Uncertainty for a Level of Confidence of 95% ( $U=2Uc(y)$ ): 150kHz~30MHz: $\pm 3.46\text{dB}$
<b>Radiated Emission Measurement</b>
Measuring Uncertainty for a Level of Confidence of 95% ( $U=2Uc(y)$ ): 9kHz ~ 1GHz: $\pm 4.18\text{dB}$ 1GHz ~ 25GHz: $\pm 4.76\text{dB}$



## 7. TEST RESULT

### 7.1. Summary

**Company Name:** Shenzhen Zhonghenghua Technology CO.,Ltd  
**FCC ID:** 2ACZWBT004  
**Method/System:** Frequency Hopping Spread Spectrum (FHSS)  
**Number of Channels:** 79

FCC Part Section(s)	Test Description	Test Limit	Test Condition	Test Result	Reference
15.247(a)(1)	20dB Bandwidth	N/A	Conducted	PASS	Section 7.2
15.247(b)(1)	Peak Transmitter Output Power	<1 Watt if > 75 non-overlapping channels used		PASS	Section 7.3
15.247(a)(1)	Channel Separation	> 2/3 of 20 dB BW for systems with Output Power < 125mW		PASS	Section 7.4
15.247(a)(1)(iii)	Number of Channels	> 15 Channels		PASS	Section 7.5
15.247(a)(1)(iii)	Time of Occupancy	< 0.4 sec in 31.6 sec period		PASS	Section 7.6
15.247(d)	Band Edge / out- of-Band Emissions	Conducted $\geq$ 20dBc		PASS	Section 7.7, Section 7.8
15.205 15.209	General Field Strength Limits (Restricted Bands and Radiated Emission Limits)	Emissions in restricted bands must meet the radiated limits detailed in 15.209	Radiated	PASS	Section 7.9, Section 7.10
15.207	AC Conducted Emissions 150kHz - 30MHz	< FCC 15.207 limits	Line Conducted	Pass	Section 7.11

#### Notes:

- 1) All modes of operation and data rates were investigated. For radiated emission test, every axis (X, Y, Z) was also verified. The test results shown in the following sections represent the worst case emissions.
- 2) The analyzer plots shown in this section were all taken with a correction table loaded into the analyzer. The correction table was used to account for the losses of the cables and attenuators used as part of the system to connect the EUT to the analyzer at all frequencies of interest.
- 3) All antenna port conducted emissions testing was performed on a test bench with the antenna port of the EUT connected to the spectrum analyzer through calibrated cables and attenuators.

## **7.2. 20dB Bandwidth Measurement**

### **7.2.1. Test Limit**

N/A

### **7.2.2. Test Procedure used**

ANSI C63.10-2009 - Section 6.9.1

### **7.2.3. Test Setting**

1. Set RBW  $\geq$  1% of the 20dB bandwidth
2. VBW  $\geq$  3  $\times$  RBW
3. Span = approximately 2 to 3 times the 20dB bandwidth, centered on a hopping channel
4. Detector = Peak
5. Trace mode = max hold
6. Sweep = auto couple
7. Allow the trace to stabilize
8. Measure the maximum width of the emission that is constrained by the frequencies associated with the two outermost amplitude points (upper and lower frequencies) that are attenuated by 20 dB relative to the maximum level measured in the fundamental emission.

### 7.2.4. Test Setup

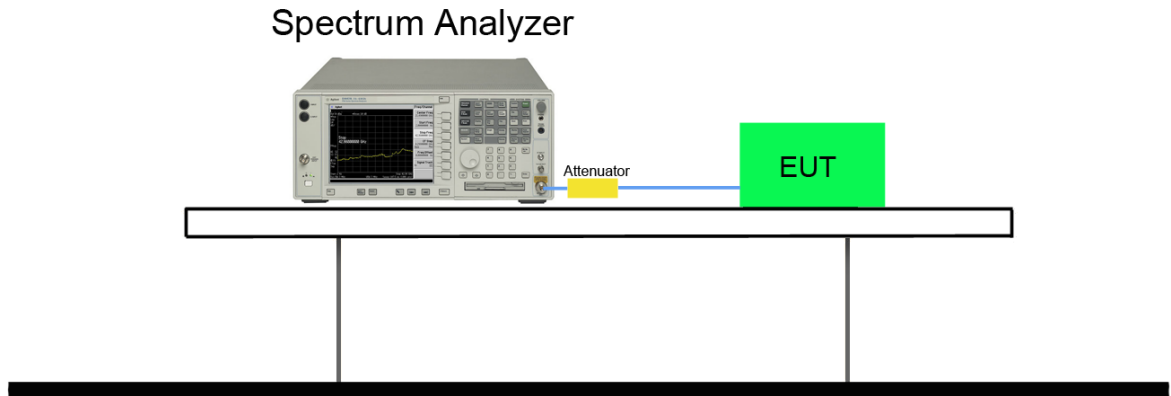

### 7.2.5. Test Result

Test Mode	Channel No.	Frequency (MHz)	20dB Bandwidth (kHz)	Result
DH5	00	2402	938.6	Pass
DH5	39	2441	922.2	Pass
DH5	78	2480	921.7	Pass
2DH5	00	2402	1255.0	Pass
2DH5	39	2441	1255.0	Pass
2DH5	78	2480	1255.0	Pass
3DH5	00	2402	1262.0	Pass
3DH5	39	2441	1262.0	Pass
3DH5	78	2480	1260.0	Pass

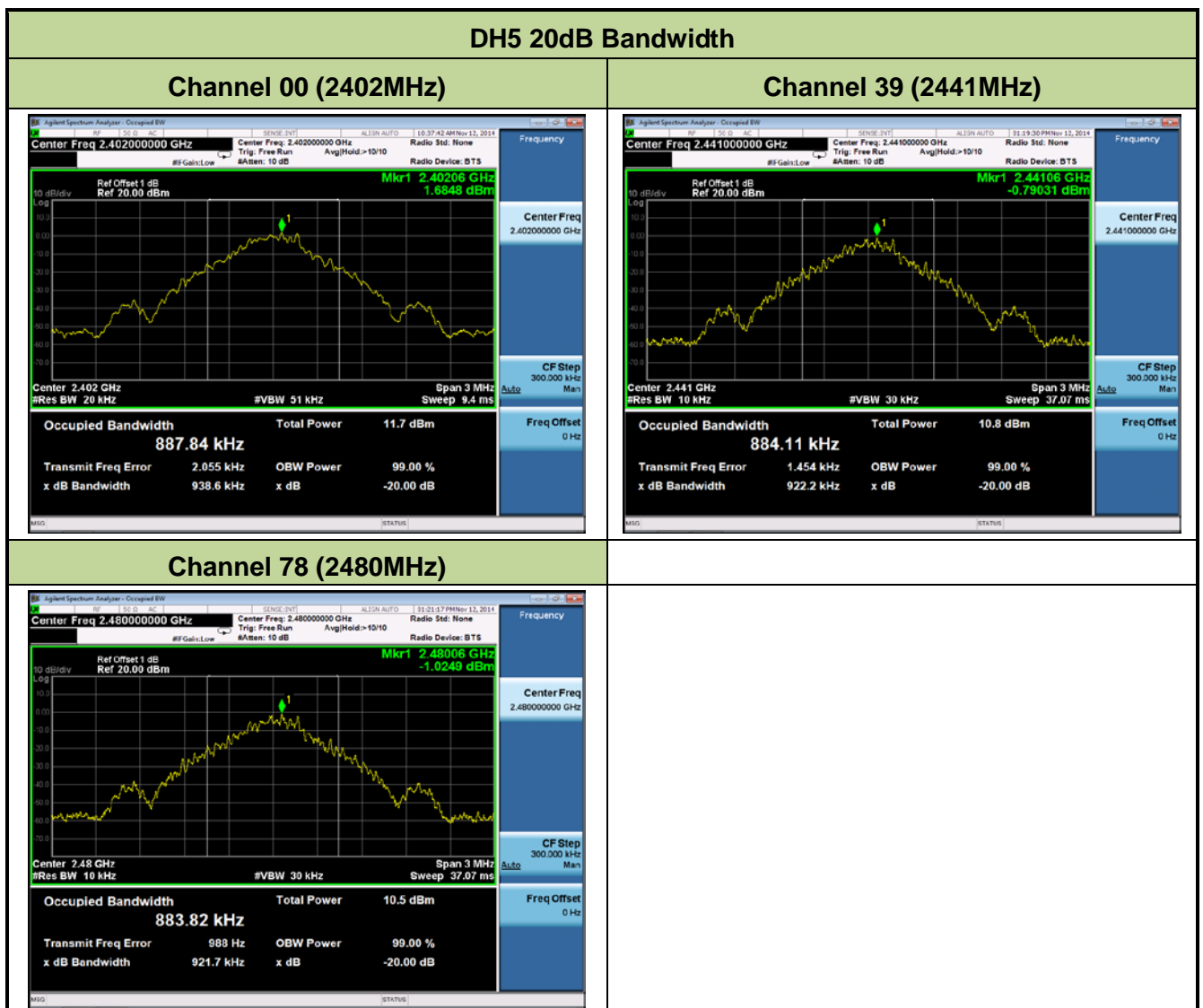

### 2DH5 20dB Bandwidth

#### Channel 00 (2402MHz)

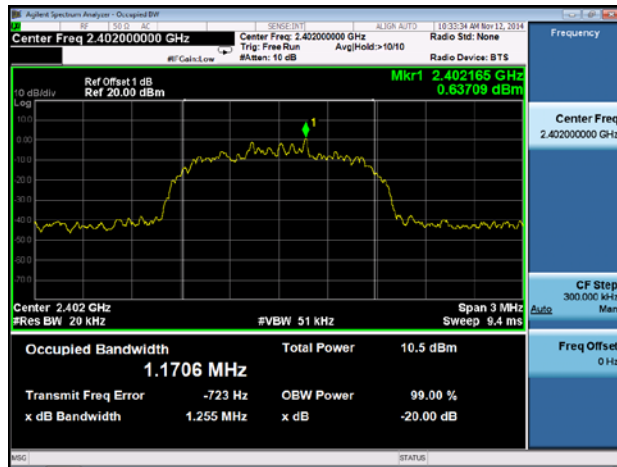

#### Channel 39 (2441MHz)

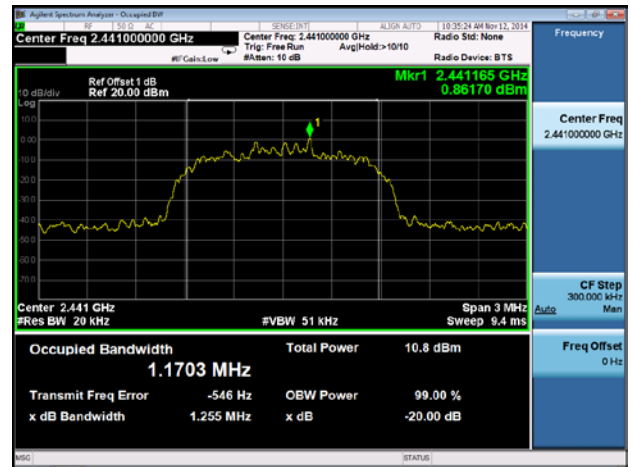

#### Channel 78 (2480MHz)

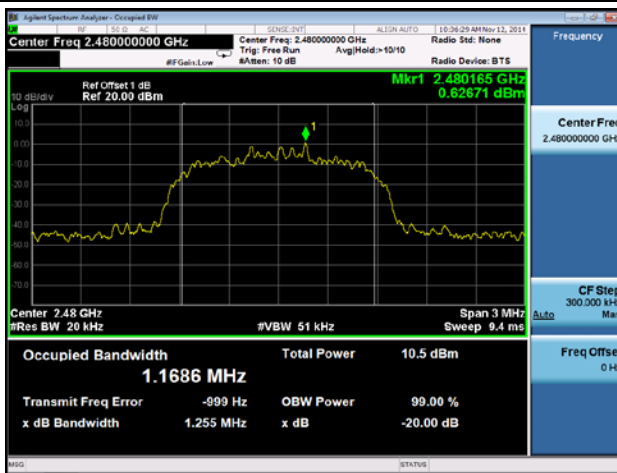

### 3DH5 20dB Bandwidth

#### Channel 00 (2402MHz)

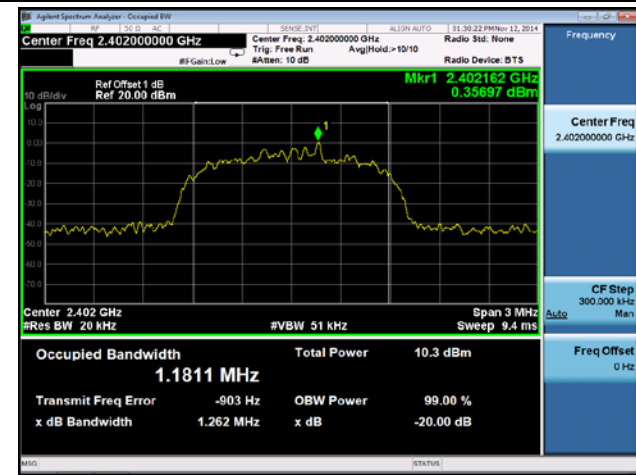

#### Channel 39 (2441MHz)

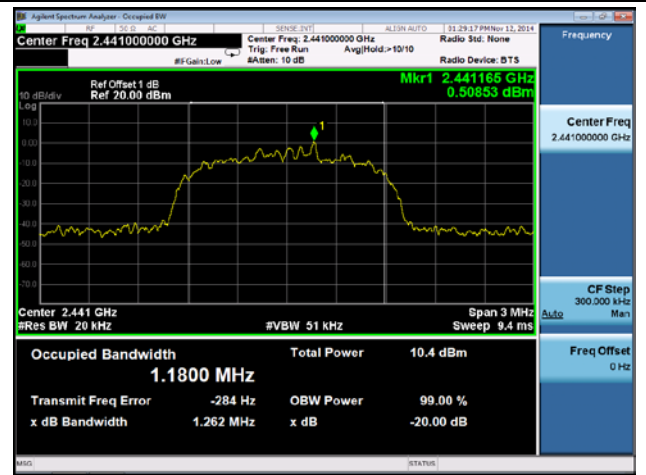

#### Channel 78 (2480MHz)

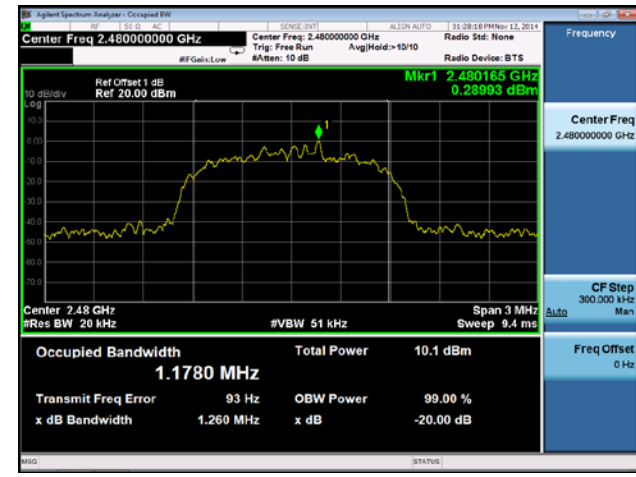

## **7.3. Output Power Measurement**

### **7.3.1. Test Limit**

The maximum out power permissible output power is 1 Watt for all other frequency hopping systems operating in the 2400-2483.5 MHz band employing at least 75 non-overlapping hopping channels.

### **7.3.2. Test Procedure Used**

ANSI C63.10-2009 - Section 6.10.1

### **7.3.3. Test Setting**

1. Set RBW  $\geq$  the 20 dB bandwidth of the emission being measured.
2. VBW  $\geq 3 \times$  RBW
3. Span = approximately 2 to 3 times the 20dB bandwidth, centered on a hopping channel
4. Detector = Peak
5. Trace mode = max hold
6. Sweep = auto couple
7. Allow the trace to stabilize, Use the marker-to-peak function to set the marker to the peak of the emission. The indicated level is the peak output power (don't forget added the external attenuation and cable loss)

### 7.3.4. Test Setup

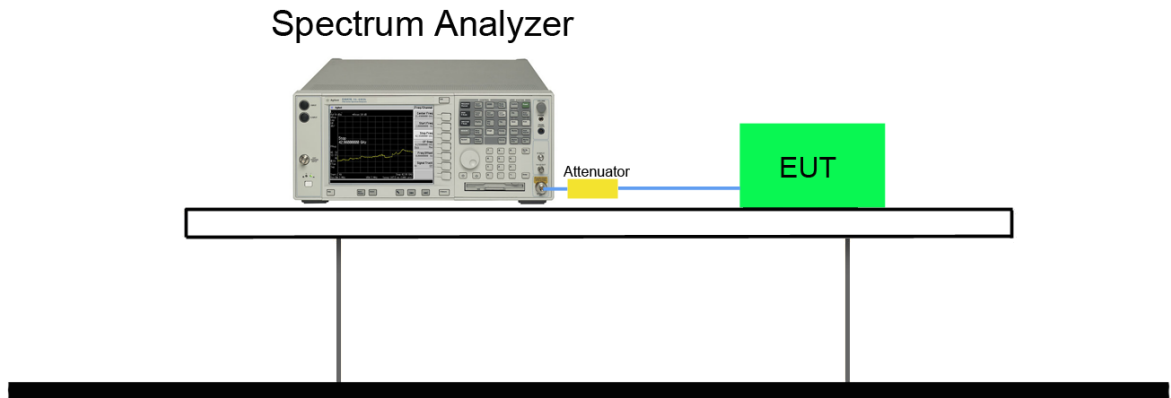



7.3.5. Test Result

Test Mode	Channel No.	Frequency (MHz)	Peak Power		
			(dBm)	(mW)	Limit (W)
DH5	00	2402	5.563	3.600	< 1
DH5	39	2441	5.660	3.681	< 1
DH5	78	2480	5.530	3.573	< 1
2DH5	00	2402	5.687	3.704	< 1
2DH5	39	2441	5.728	3.739	< 1
2DH5	78	2480	5.532	3.574	< 1
3DH5	00	2402	5.735	3.745	< 1
3DH5	39	2441	5.802	3.804	< 1
3DH5	78	2480	5.584	3.617	< 1

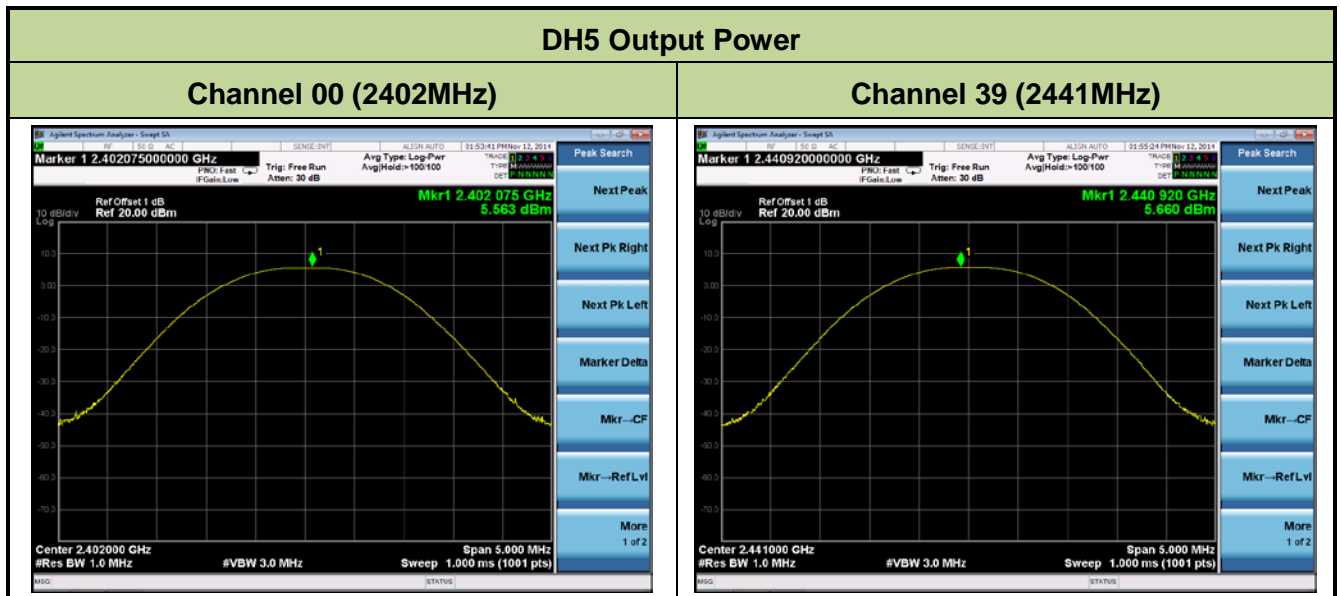

### Channel 78 (2480MHz)

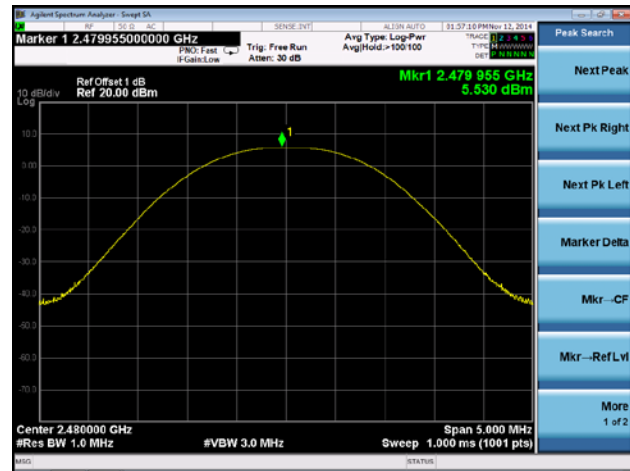

### 2DH5 Output Power

### Channel 00 (2402MHz)



### Channel 39 (2441MHz)



### Channel 78 (2480MHz)

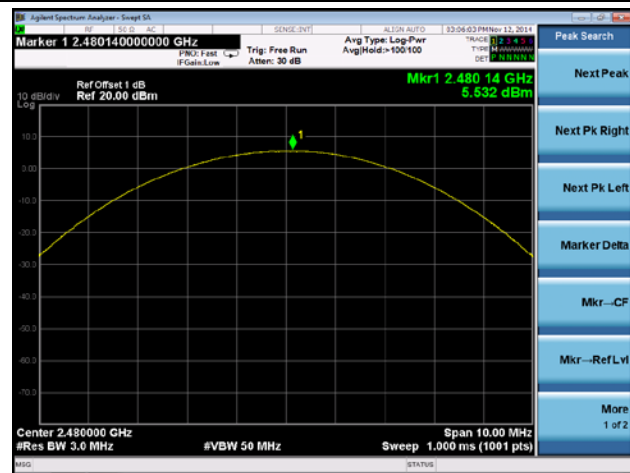



## 7.4. Carrier Frequency Separation Measurement

### 7.4.1. Test Limit

The minimum permissible channel separation for this system is 2/3 the value of the 20dB BW.

### 7.4.2. Test Procedure Used

ANSI C63.10-2009 - Section 7.7.2

### 7.4.3. Test Setting

1. Span = wide enough to capture the peaks of two adjacent channels.
2. RBW  $\geq$  1 % of the span
3. VBW  $\geq$  RBW
4. Detector = peak
5. Sweep time = auto couple
6. Trace mode = max hold
7. Trace was allowed to stabilize

### 7.4.4. Test Setup

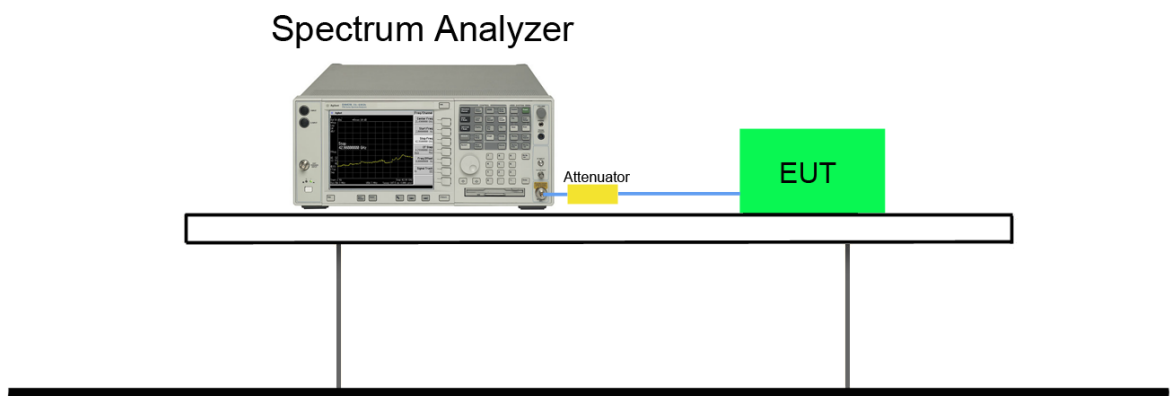

**7.4.5. Test Result**

Test Mode	Channel No.	Frequency (MHz)	Limit (KHz)	Result
DH5	00	2402	≥ 625.7	Pass
DH5	39	2441	≥ 614.8	Pass
DH5	78	2480	≥ 614.5	Pass
2DH5	00	2402	≥ 836.7	Pass
2DH5	39	2441	≥ 836.7	Pass
2DH5	78	2480	≥ 836.7	Pass
3DH5	00	2402	≥ 841.3	Pass
3DH5	39	2441	≥ 841.3	Pass
3DH5	78	2480	≥ 840.0	Pass

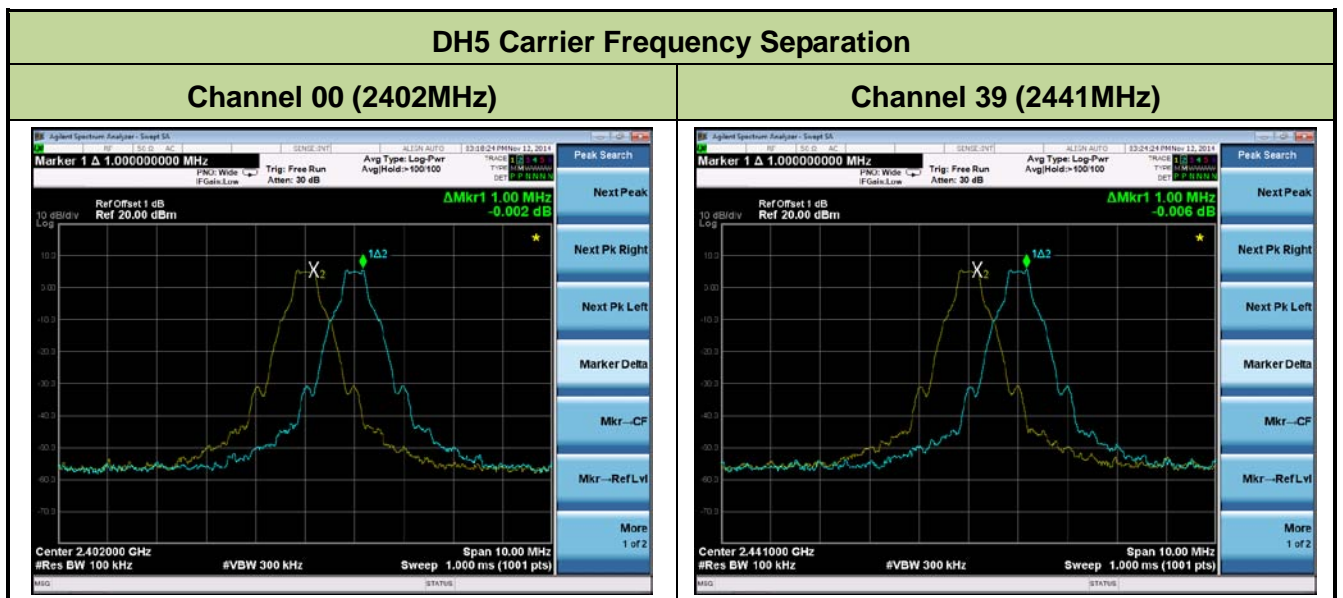

**Channel 78 (2480MHz)**

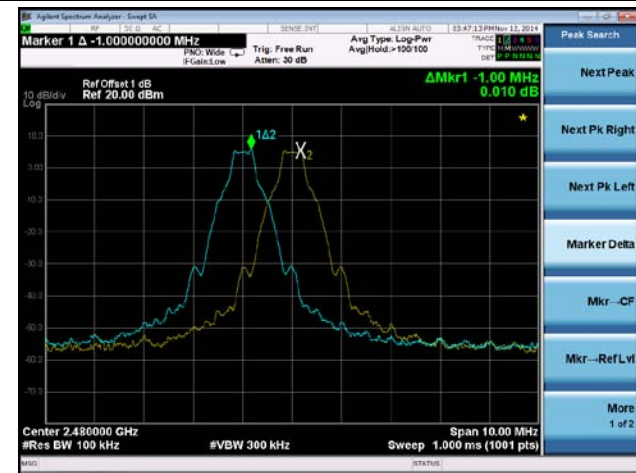

**2DH5 Carrier Frequency Separation**

**Channel 00 (2402MHz)**

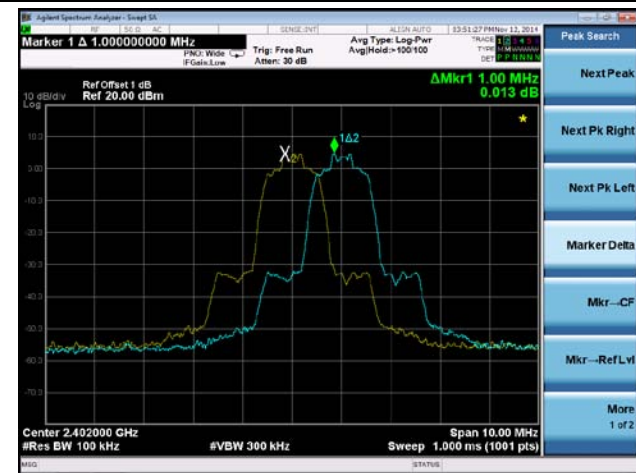

**Channel 39 (2441MHz)**

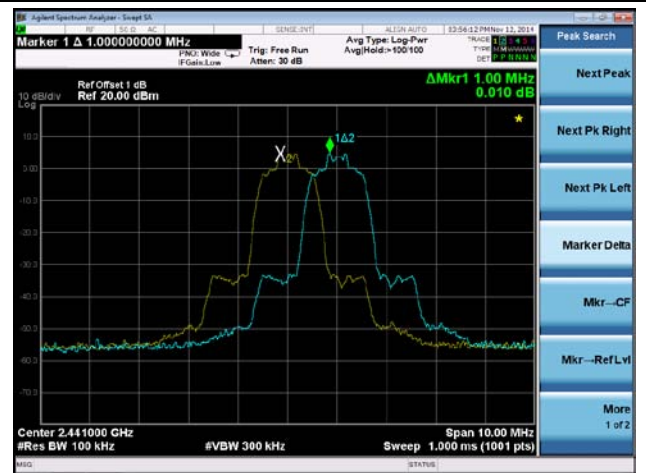

**Channel 78 (2480MHz)**

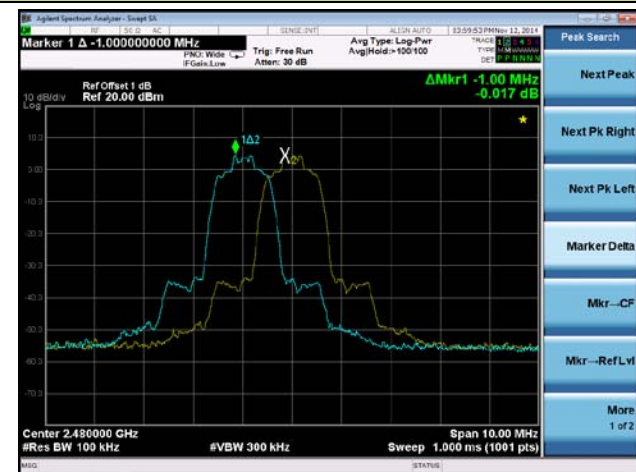

### 3DH5 Carrier Frequency Separation

Channel 00 (2402MHz)

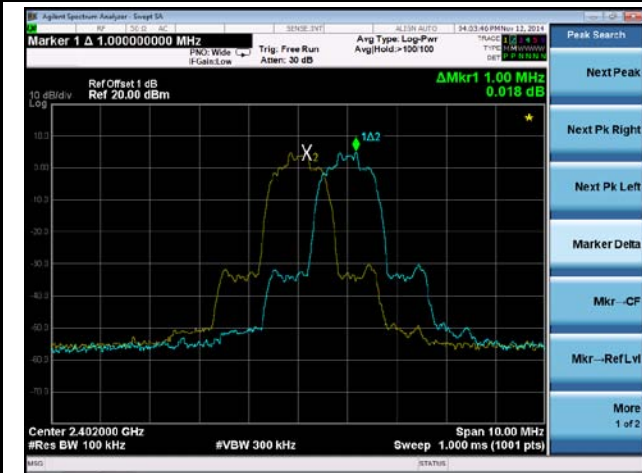

Channel 39 (2441MHz)

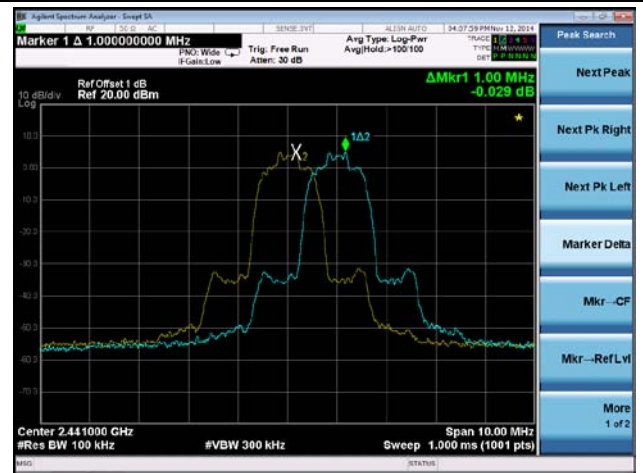

Channel 78 (2480MHz)

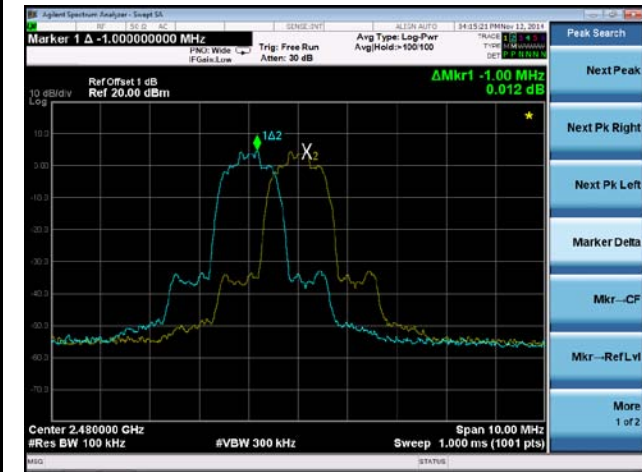



## 7.5. Number of Hopping Channels Measurement

### 7.5.1. Test Limit

This frequency hopping system must employ a minimum of 15 hopping channels.

### 7.5.2. Test Procedure Used

ANSI C63.10-2009 - Section 7.7.3

### 7.5.3. Test Setting

1. Span = the frequency band of operation.
2. RBW  $\geq$  1 % of the span
3. VBW  $\geq$  RBW
4. Detector = Peak
5. Trace mode = max hold
6. Sweep time = auto couple
7. The trace was allowed to stabilize

### 7.5.4. Test Setup

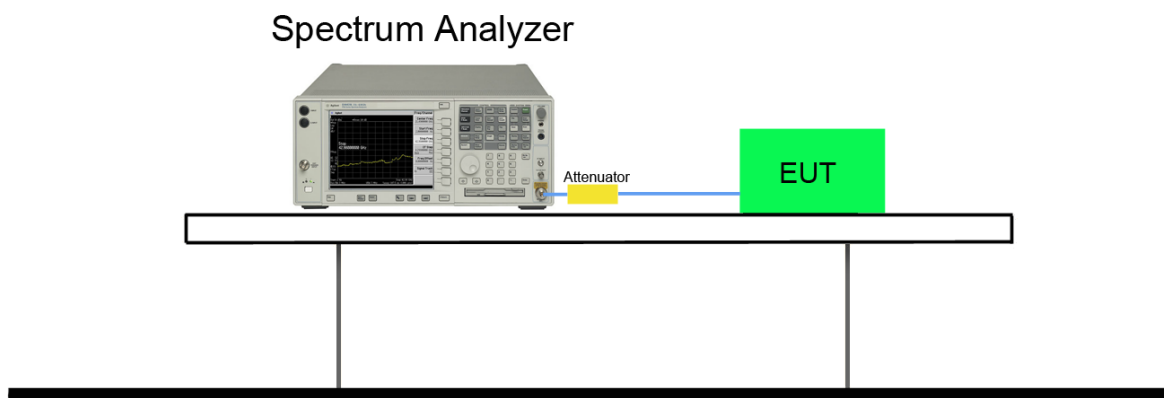



### 7.5.5. Test Result

Test Mode (Hopping)	Channel Numbers	Frequency (MHz)	Limit (Hopping Channels)	Result
DH5	79	2402~2480	≥ 15	Pass
2DH5	79	2402~2480	≥ 15	Pass
3DH5	79	2402~2480	≥ 15	Pass

#### DH5 Number of Hopping Channels

2402 ~ 2421MHz

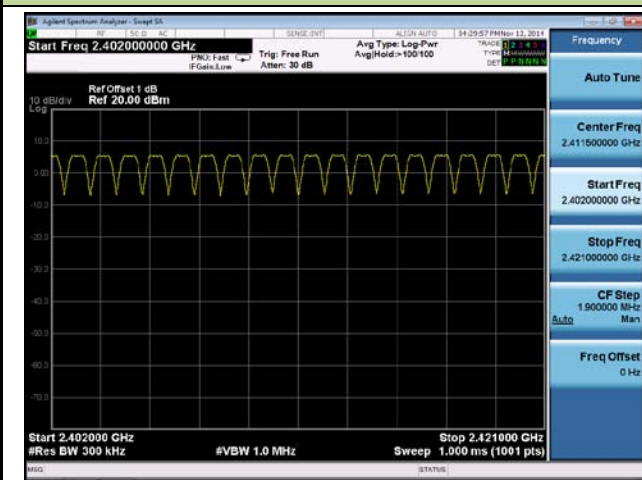

2422 ~ 2441MHz

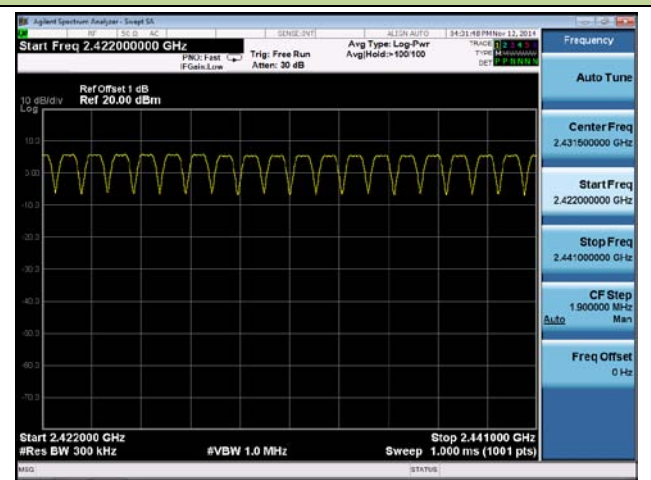

2442 ~ 2461MHz

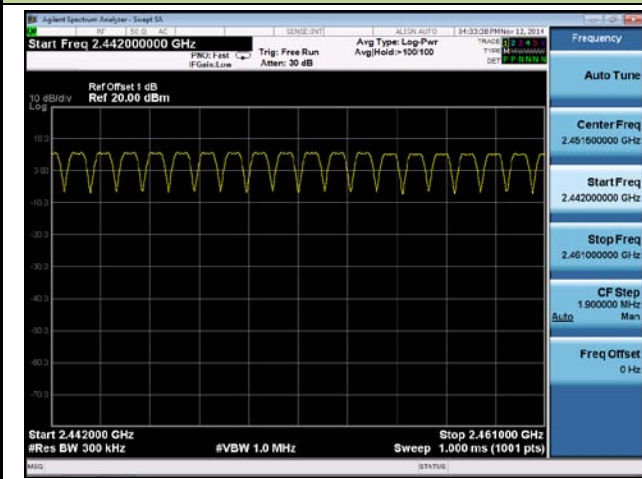

2462 ~ 2480MHz

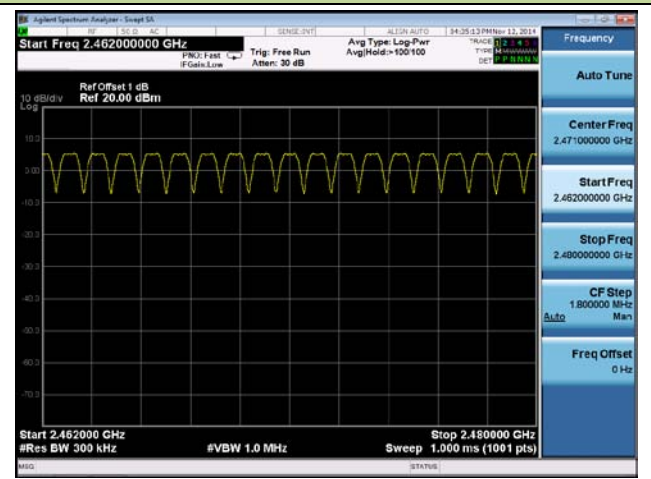

### 2DH5 Number of Hopping Channels

#### 2402 ~ 2421MHz

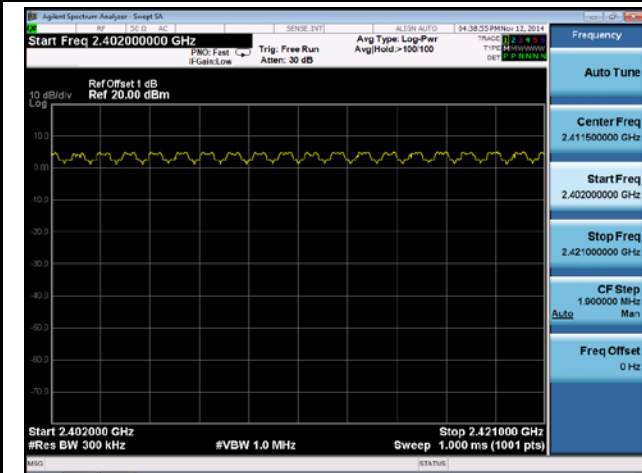

#### 2422 ~ 2441MHz

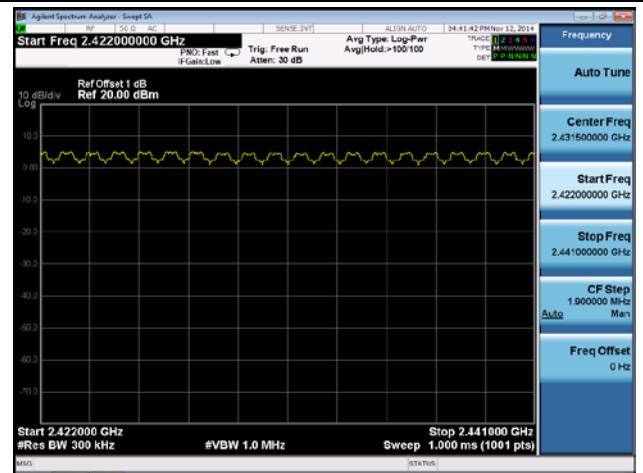

#### 2442 ~ 2461MHz

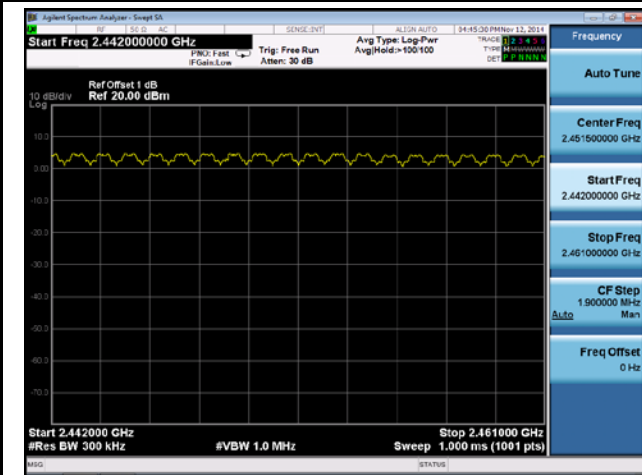

#### 2462 ~ 2480MHz

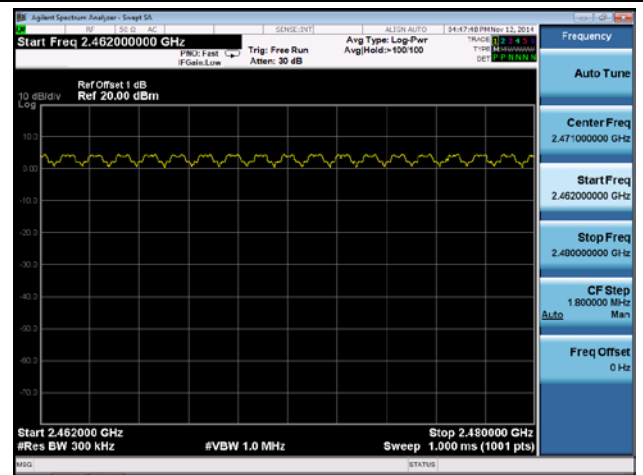

### 3DH5 Number of Hopping Channels

#### 2402 ~ 2421MHz

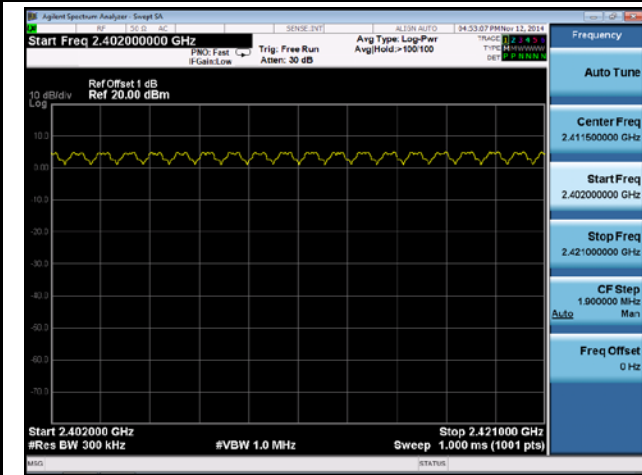

#### 2422 ~ 2441MHz

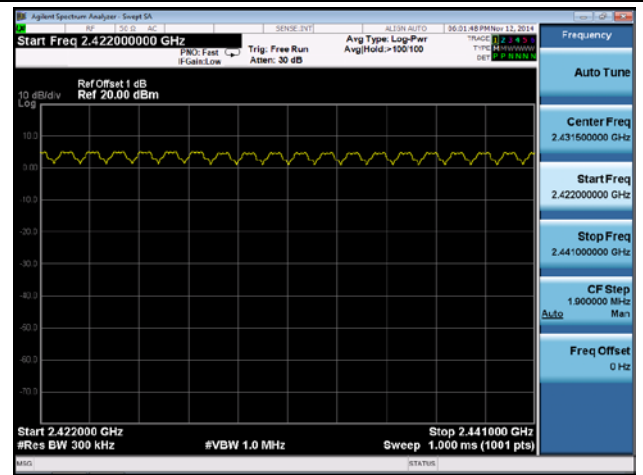

#### 2442 ~ 2461MHz

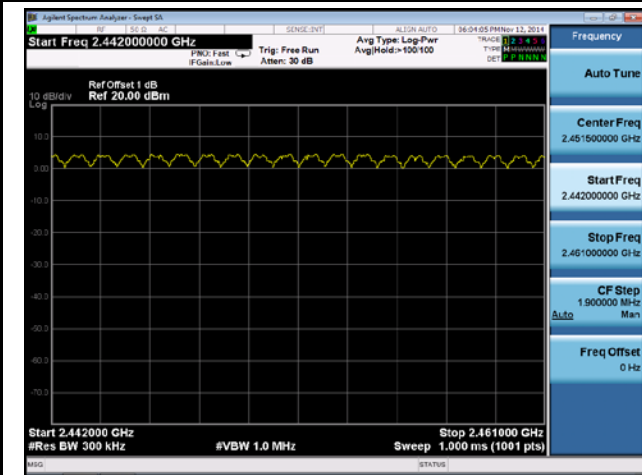

#### 2462 ~ 2480MHz

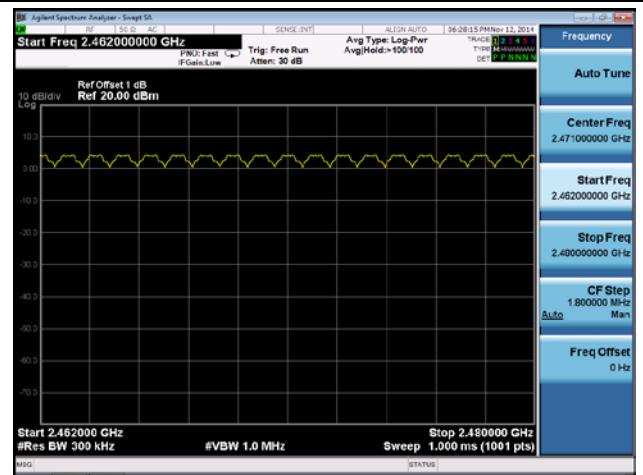

## **7.6. Time of Occupancy Measurement**

### **7.6.1. Test Limit**

The maximum permissible time of occupancy is 400ms within a period of 400ms multiplied by the number of hopping channels employed.

### **7.6.2. Test Procedure Used**

ANSI C63.10-2009 - Section 7.7.4

### **7.6.3. Test Setting**

1. Span = zero span, centered on a hopping channel.
2. RBW = 1MHz
3. VBW  $\geq$  RBW
4. Sweep time = as necessary to capture the entire dwell time per hopping channel
5. Detector = Peak
6. Trace mode = max hold

If possible, use the marker-delta function to determine the dwell time. If this value varies with different modes of operation (data rate, modulation format, etc.), repeat this test for each variation.

An oscilloscope may be used instead of a spectrum analyzer. The EUT shall show compliance with the appropriate regulatory limit for the number of hopping channels. A plot of the data shall be included in the test report.

#### 7.6.4. Test Setup

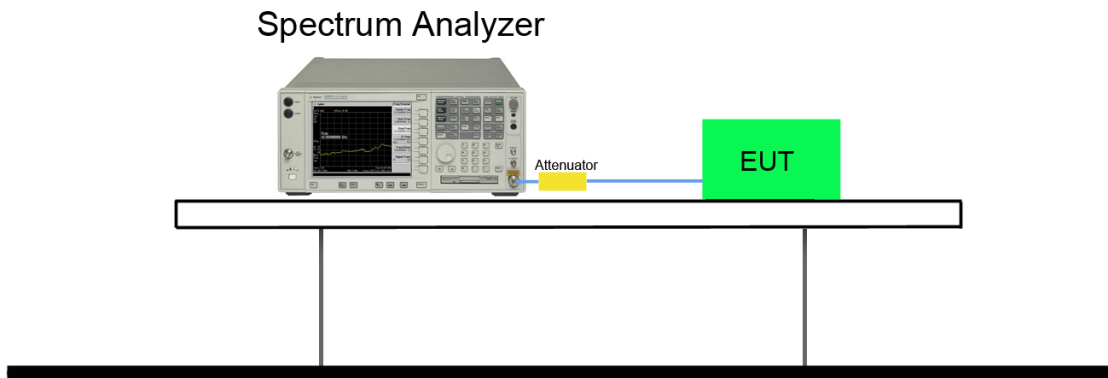

### 7.6.5. Test Result

Test Mode	Channel No.	Frequency (MHz)	Time of Occupancy (ms)	Limit (ms)	Result
3DH1	39	2441	121.60	< 400	Pass
3DH3	39	2441	260.80	< 400	Pass
3DH5	39	2441	322.56	< 400	Pass

#### 3DH1 Time of Occupancy

Channel 39(2441MHz)

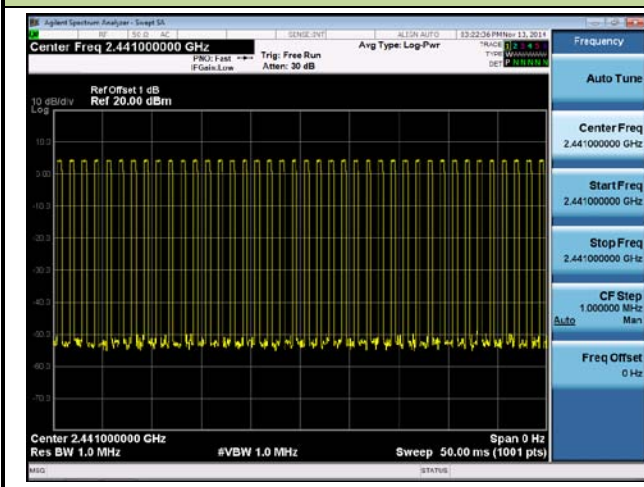

Channel 39(2441MHz)

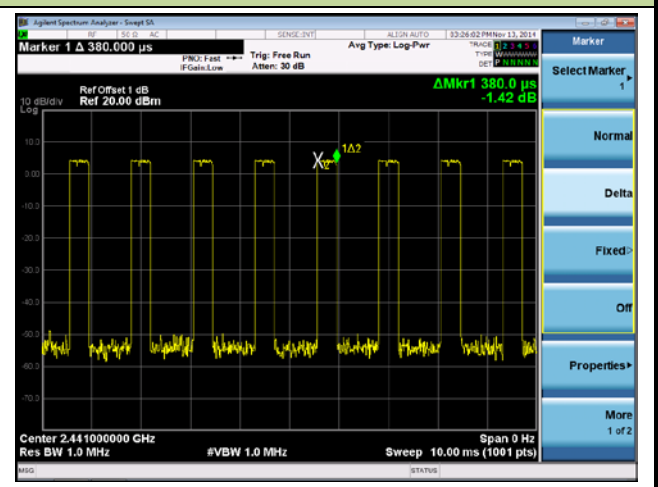

Note: Test Time Period:  $0.4 \times 79 = 31.6$ sec, Hopping Times Within 1sec:  $40/50$ msec= $800$  hops/sec.  
 The Maximum Occupancy Time within 31.6sec:  $[(0.380\text{ms} \times 800) / 79] \times 31.6 = 121.60$  msec.

#### 3DH3 Time of Occupancy

Channel 39(2441MHz)

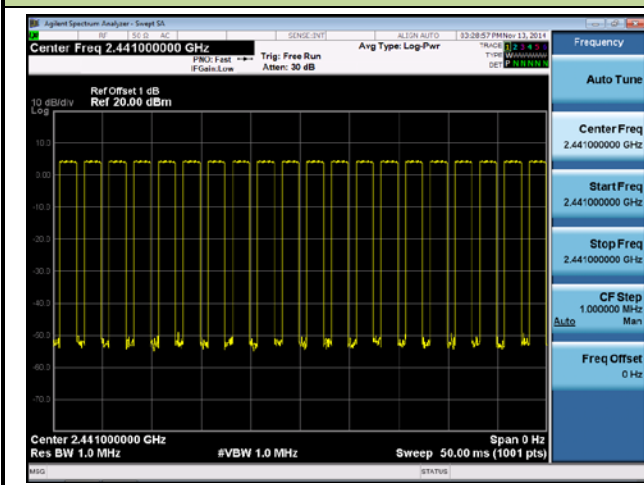

Channel 39(2441MHz)

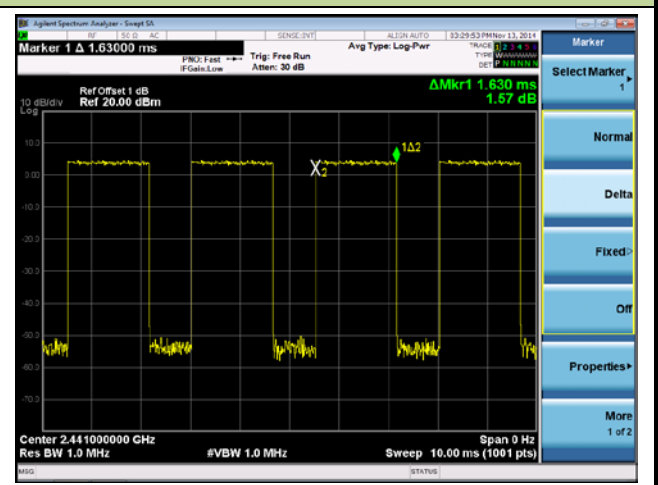

Note: Test Time Period:  $0.4 \times 79 = 31.6$ sec, Hopping Times Within 1sec:  $20/50$ msec= $400$ hops/sec.  
 The Maximum Occupancy Time within 31.6sec:  $[(1.630\text{ms} \times 400) / 79] \times 31.6 = 260.80$  msec.

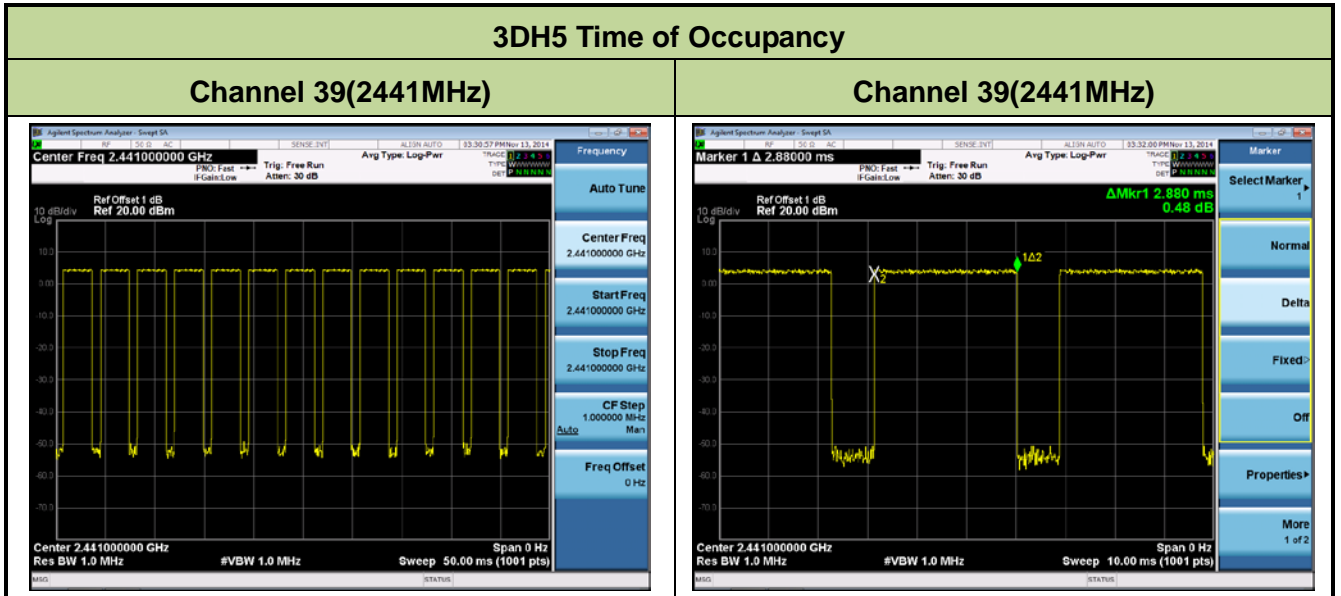

Note: Test Time Period:  $0.4 \times 79 = 31.6$ sec, Hopping Times Within 1sec:  $14/50$ msec=280 hops/sec.  
 The Maximum Occupancy Time within 31.6sec:  $[(2.880\text{ms} \times 280)/79] \times 31.6 = 322.56$  msec.

## **7.7. Band-edge Compliance Measurement**

### **7.7.1. Test Limit**

The maximum permissible emission level is 20dBc. Any emission lying outside of the emission bandwidth and in authorized band edges to a field strength limit specified in Section 15.209 of the Title 47 CFR.

### **7.7.2. Test Procedure Used**

ANSI C63.10-2009 - Section 7.7.9

### **7.7.3. Test Setting**

1. Span = wide enough to capture the peak level of the emission operating on the channel closest to the band edge, as well as any modulation products which fall outside of the authorized band of operation.
2. RBW  $\geq$  1% of spectrum analyzer display span
3. VBW  $\geq$  RBW
4. Detector = peak
5. Sweep time = auto couple
6. Trace mode = max hold
7. Trace was allowed to stabilize

Allow the trace to stabilize. Set the marker on the emission at the band edge, or on the highest modulation product outside of the band, if this level is greater than that at the band edge. Enable the marker-delta function, then use the marker-to-peak function to move the marker to the peak of the in-band emission.



### 7.7.4. Test Setup

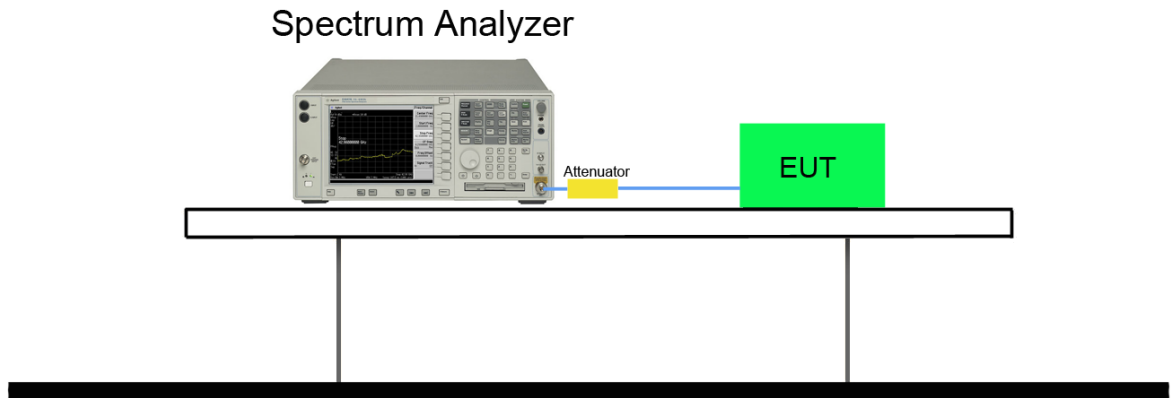

**7.7.5. Test Result**

Test Mode	Channel No.	Frequency (MHz)	Limit	Result
DH5	00	2402	20dBc	Pass
DH5	78	2480	20dBc	Pass
2DH5	00	2402	20dBc	Pass
2DH5	78	2480	20dBc	Pass
3DH5	00	2402	20dBc	Pass
3DH5	78	2480	20dBc	Pass

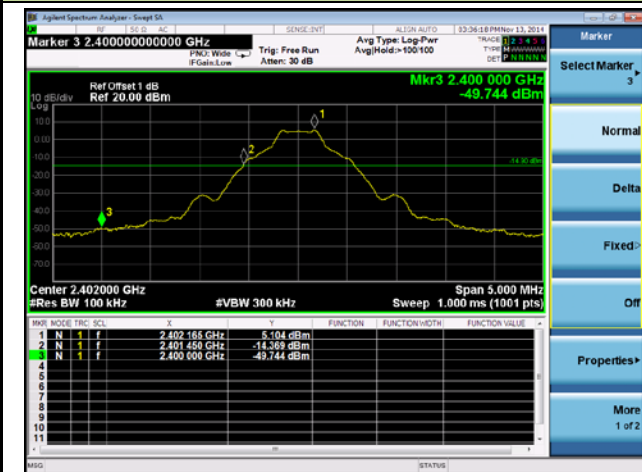
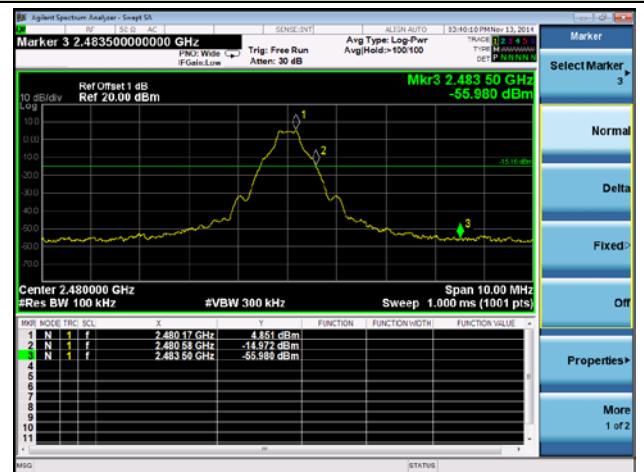
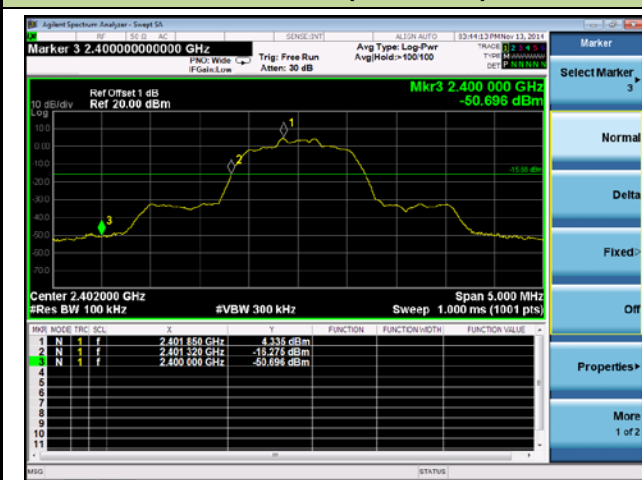
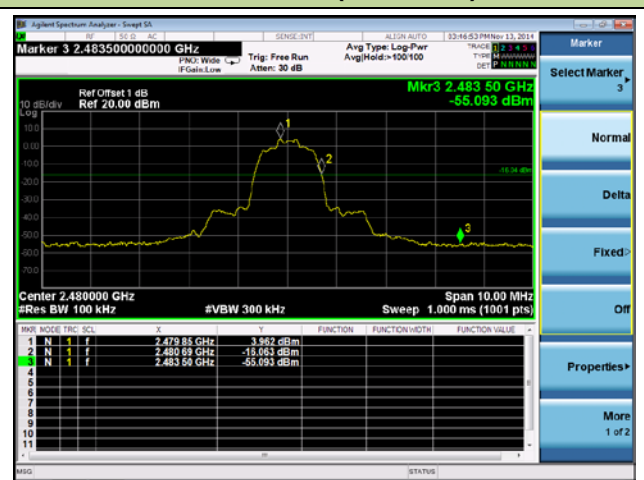
**DH5 Band-edge Compliance**
**Channel 00 (2402MHz)**

**Channel 78 (2480MHz)**

**2DH5 Band-edge Compliance**
**Channel 00 (2402MHz)**

**Channel 78 (2480MHz)**

### 3DH5 Band-edge Compliance

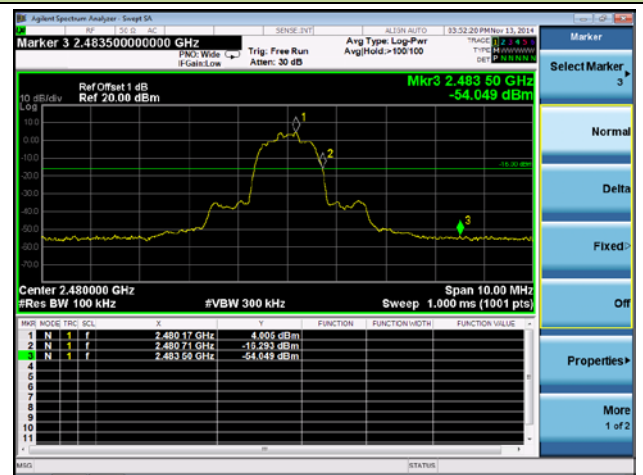
Channel 00 (2402MHz)



Channel 78 (2480MHz)



### DH5 Operation Frequency Range of 20dB Bandwidth within Hopping Mode

Channel 00 (2402MHz)

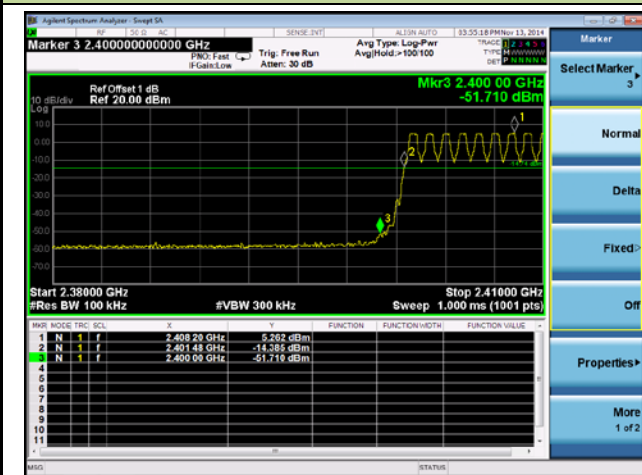

Channel 78 (2480MHz)

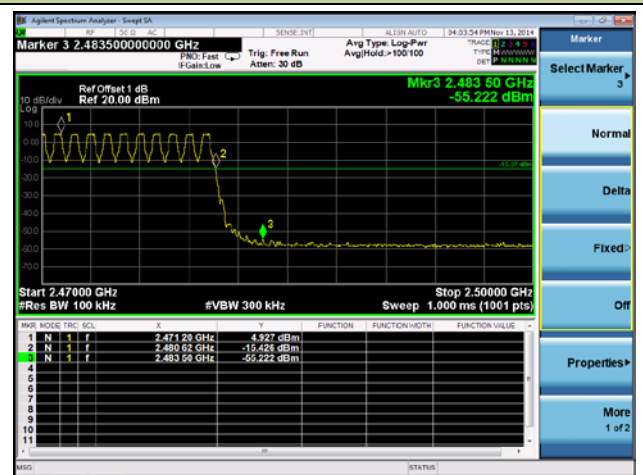

### 2DH5 Operation Frequency Range of 20dB Bandwidth within Hopping Mode

Channel 00 (2402MHz)

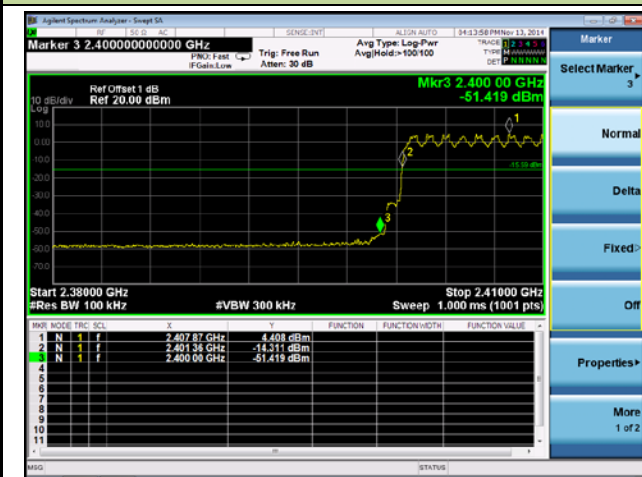

Channel 78 (2480MHz)

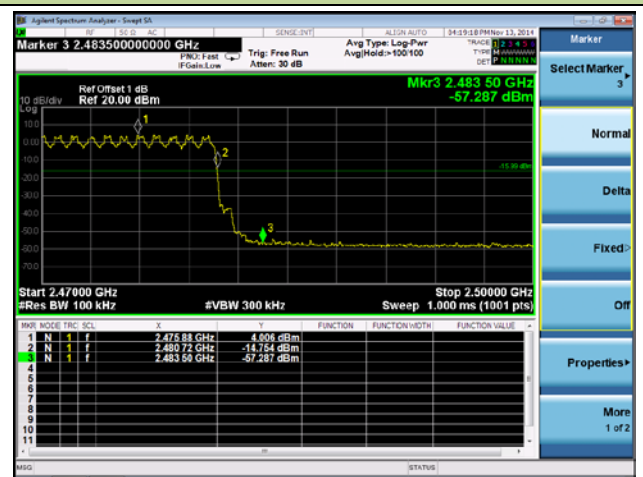

### 3DH5 Operation Frequency Range of 20dB Bandwidth within Hopping Mode

#### Channel 00 (2402MHz)

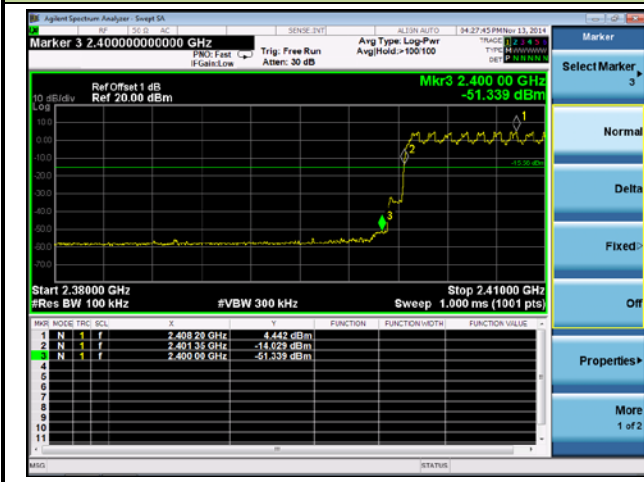

#### Channel 78 (2480MHz)

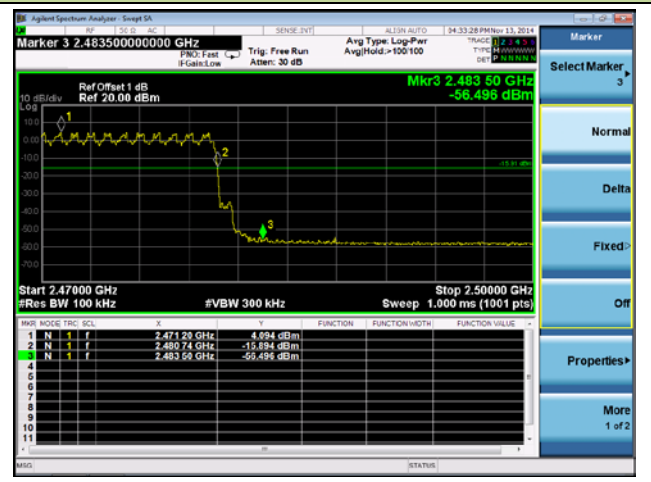

## **7.8. Conducted Spurious Emissions Measurement**

### **7.8.1. Test Limit**

In any 100 kHz bandwidth outside the frequency band in which the spread spectrum or digitally modulated intentional radiator is operating, the radio frequency power that is produced by the intentional radiator shall be at least 20 dB below that in the 100 kHz bandwidth within the band that contains the highest level of the desired power, based on either an RF conducted or a radiated measurement, provided the transmitter demonstrates compliance with the peak conducted or a radiated measurement, provided the transmitter demonstrates compliance with the peak conducted power limits. If the transmitter complies with the conducted power limits based on the use of RMS averaging over a time interval, the attenuation required under this paragraph shall be 30 dB instead of 20 dB.

### **7.8.2. Test Procedure Used**

ANSI C63.10-2009 - Section 7.7.10

### **7.8.3. Test Setting**

1. Span = wide enough to capture the peak level of the in-band emission and all spurious emissions (e.g., harmonics) from the lowest frequency generated in the EUT up through the 10<sup>th</sup> harmonic. Typically, several plots are required to cover this entire span.
2. RBW = 100 KHz
3. VBW  $\geq$  RBW
4. Detector = peak
5. Sweep time = auto couple
6. Trace mode = max hold
7. Trace was allowed to stabilize

Set the marker on the peak of any spurious emission recorded. The level displayed must comply with the limit specified in this section.

### 7.8.4. Test Setup

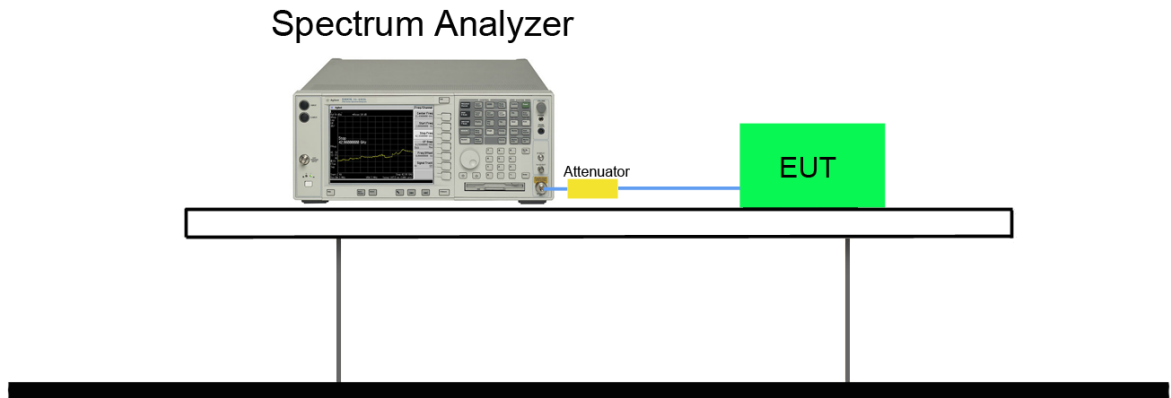

7.8.5. Test Result

Test Mode	Channel No.	Frequency (MHz)	Limit (MHz)	Result
DH5	00	2402	20dBc	Pass
DH5	39	2441	20dBc	Pass
DH5	78	2480	20dBc	Pass
2DH5	00	2402	20dBc	Pass
2DH5	39	2441	20dBc	Pass
2DH5	78	2480	20dBc	Pass
3DH5	00	2402	20dBc	Pass
3DH5	39	2441	20dBc	Pass
3DH5	78	2480	20dBc	Pass

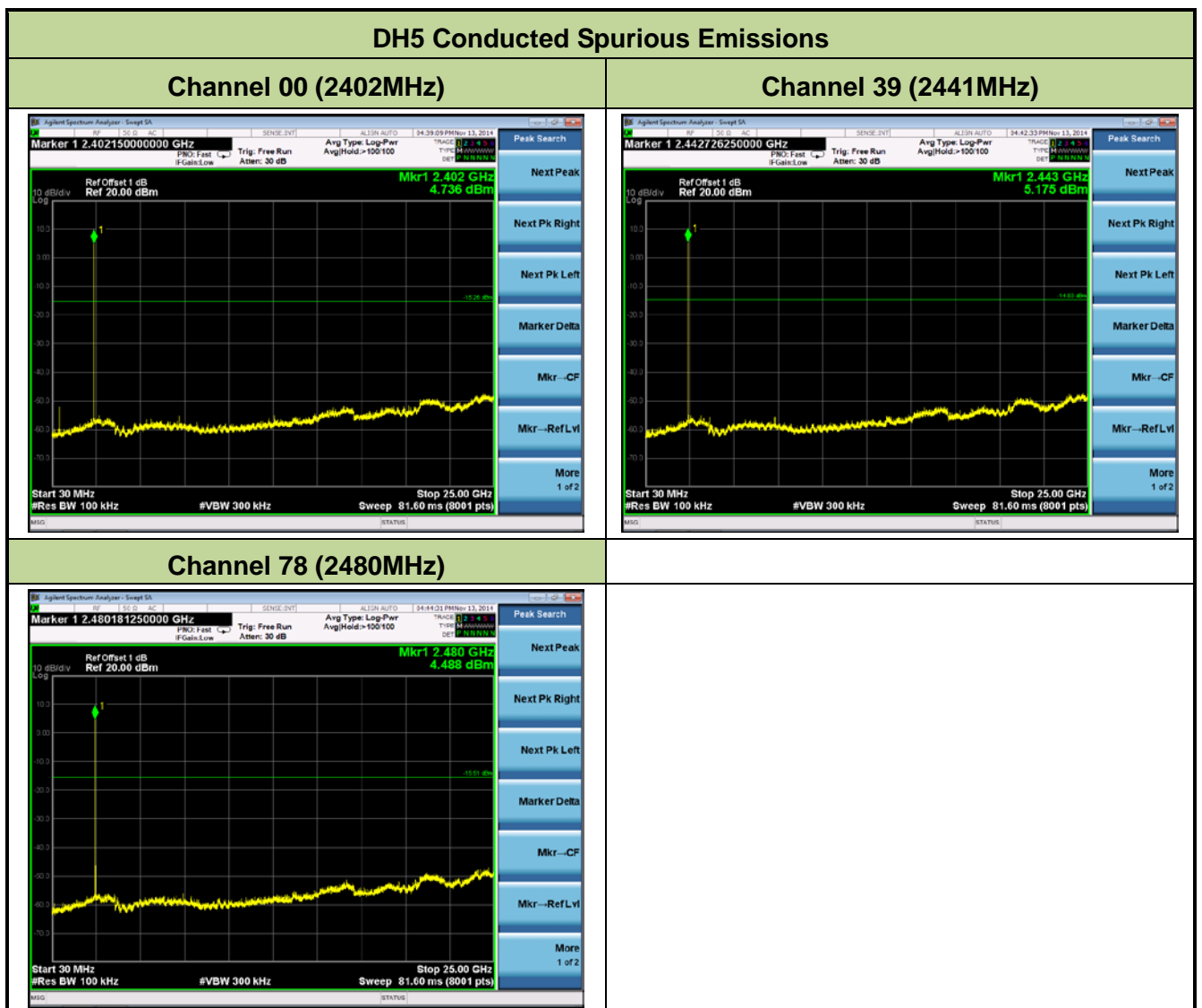

### 2DH5 Conducted Spurious Emissions

Channel 00 (2402MHz)



Channel 39 (2441MHz)



Channel 78 (2480MHz)





### 3DH5 Conducted Spurious Emissions

Channel 00 (2402MHz)



Channel 39 (2441MHz)



Channel 78 (2480MHz)



## 7.9. Radiated Spurious Emission Measurement

### 7.9.1. Test Limit

All out of band emissions appearing in a restricted band as specified in Section 15.205 of the Title 47 CFR must not exceed the limits shown in Table per Section 15.209.

FCC Part 15 Subpart C Paragraph 15.209		
Frequency [MHz]	Field Strength [V/m]	Measured Distance [Meters]
0.009 - 0.490	2400/F (kHz)	300
0.490 - 1.705	24000/F (kHz)	30
1.705 - 30	30	30
30 - 88	100	3
88 - 216	150	3
216 - 960	200	3
Above 960	500	3

### 7.9.2. Test Procedure Used

ANSI C63.10-2009 - Section 7.10.1 & Section 7.10.2

### 7.9.3. Test Setting

#### Peak Field Strength Measurements

1. Analyzer center frequency was set to the frequency of the radiated spurious emission of interest
2. RBW = as specified in Table 1
3. VBW = 3 \* RBW
4. Detector = peak
5. Sweep time = auto couple
6. Trace mode = max hold
7. Trace was allowed to stabilize

**Table 1 - RBW as a function of frequency**

Frequency	RBW
9 ~ 150 kHz	200 ~ 300 Hz
0.15 ~ 30 MHz	9 ~ 10 kHz
30 ~ 1000 MHz	100 ~ 120 kHz
> 1000 MHz	1 MHz

**Average Field Strength Measurements**

1. Analyzer center frequency was set to the frequency of the radiated spurious emission of interest
2. RBW = 1MHz
3. VBW  $\geq$  1/T
4. De As an alternative, the instrument may be set to linear detector mode. Ensure that video filtering is applied in linear voltage domain (rather than in a log or dB domain). Some instruments require linear display mode in order to accomplish this. Others have a setting for Average-VBW Type, which can be set to "Voltage" regardless of the display mode
5. Detector = Peak
6. Sweep time = auto
7. Trace mode = max hold
8. Allow max hold to run for at least 50 times (1/duty cycle) traces

### 7.9.4. Test Setup

#### 9kHz ~ 30MHz Test Setup:

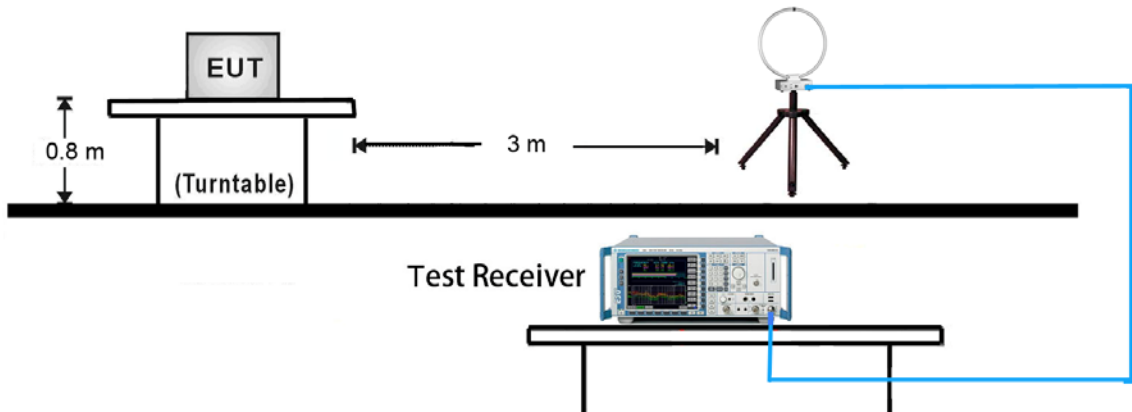

#### 30MHz ~ 1GHz Test Setup:

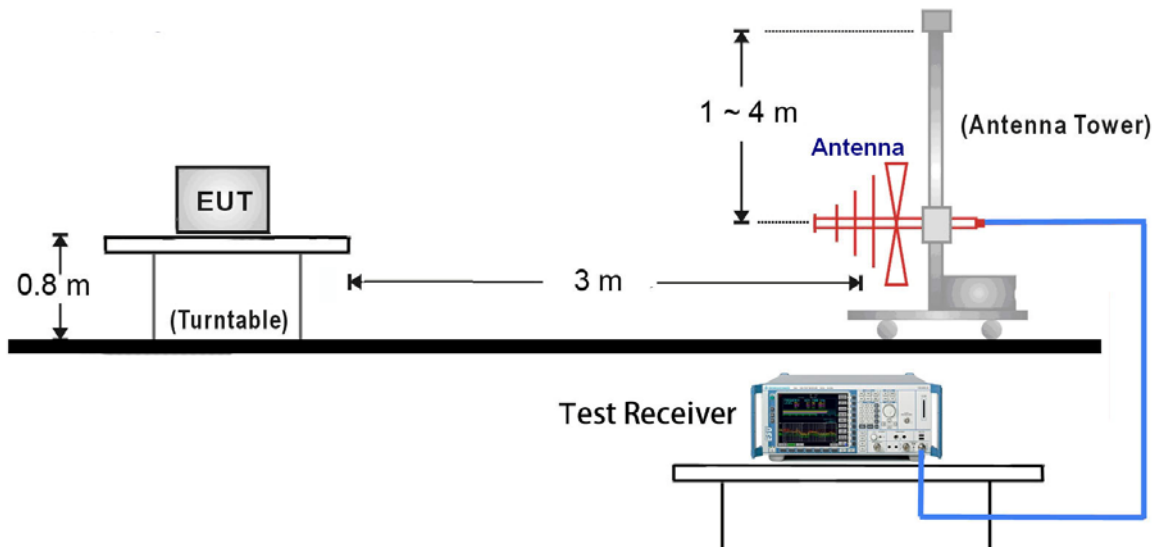

1GHz ~ 25GHz Test Setup:

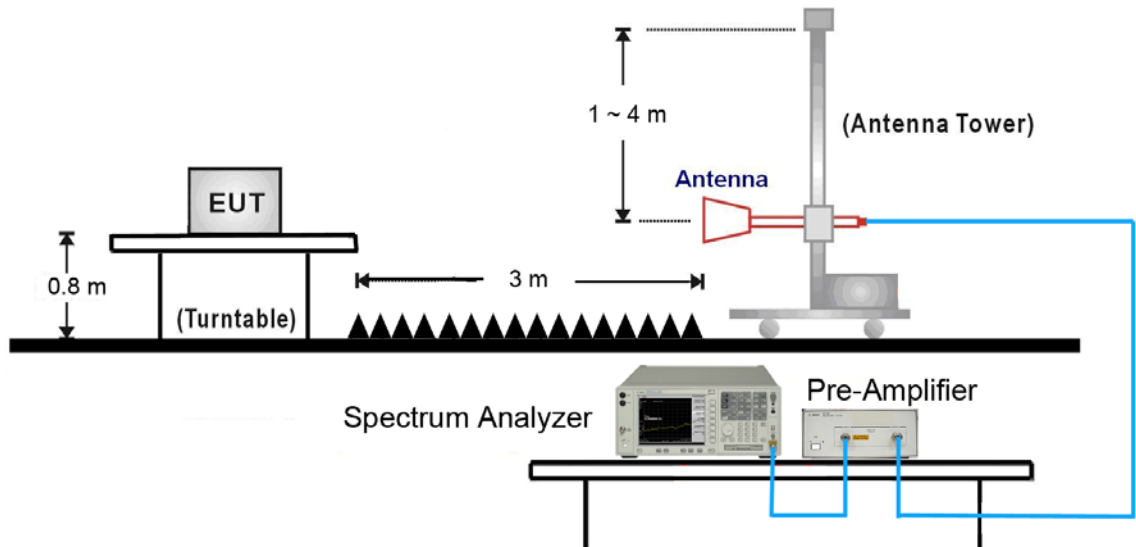

**7.9.5. Test Result**

Test Mode:	DH5	Test Site:	AC1
Test Channel:	78	Test Engineer:	Roy Cheng
Remark:	1. Average measurement was not performed if peak level lower than average limit. 2. <b>The worst case of Radiated Spurious Emission.</b> 3. Other frequency was 20dB below limit line within 1-18GHz, there is not show in the report.		

Mark	Frequency (MHz)	Reading Level (dB $\mu$ V)	Factor (dB)	Measure Level (dB $\mu$ V/m)	Limit (dB $\mu$ V/m)	Margin (dB)	Detector	Polarization
*	3025.0	37.0	3.4	40.4	74.0	-33.6	Peak	Horizontal
*	4412.0	36.5	5.5	42.0	74.0	-32.0	Peak	Horizontal
	4960.0	37.4	6.4	43.8	74.0	-30.2	Peak	Horizontal
	7440.0	35.5	13.9	49.4	74.0	-24.6	Peak	Horizontal
*	3125.0	36.7	3.5	40.2	74.0	-33.8	Peak	Vertical
*	4413.0	37.5	5.5	43.0	74.0	-31.0	Peak	Vertical
	4960.0	37.3	6.4	43.7	74.0	-30.3	Peak	Vertical
	7440.0	35.3	13.9	49.2	74.0	-24.8	Peak	Vertical

Note 1: "\*" is not in restricted band, its limit is 20dBc of the fundamental emission level (93.4dB $\mu$ V/m) or 15.209 which is higher.

Note 2: Measure Level (dB $\mu$ V/m) = Reading Level (dB $\mu$ V) + Factor (dB)

Factor (dB) = Cable Loss (dB) + Antenna Factor (dB/m) - Pre\_Amplifier Gain (dB)

**The worst case of Radiated Emission 9KHz ~ 1GHz and 18GHz ~ 25GHz:**

Site: AC1	Time: 2014/11/14 - 16:07
Limit: FCC_Part15.209_RE(3m)	Engineer: Roy Cheng
Probe: VULB9162_0.03-8GHz	Polarity: Horizontal
EUT: Wireless Selfie Sticks	Power: By Battery
<b>Worst Test Mode: 2DH5 at channel 2441MHz</b>	

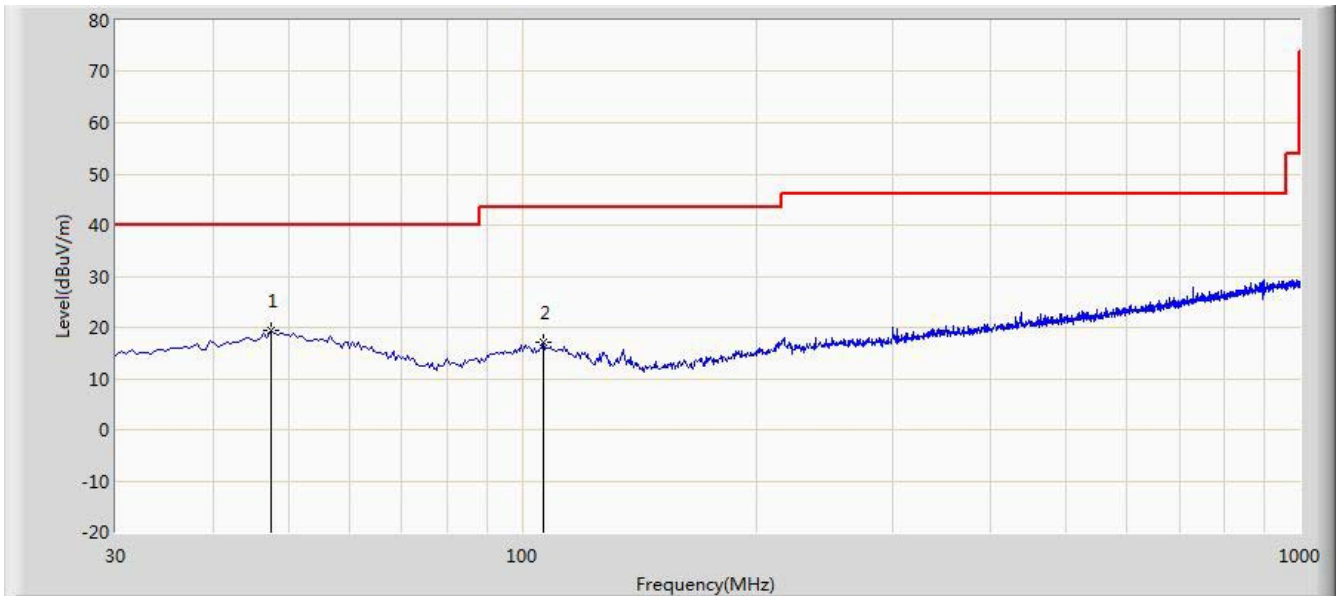

No	Frequency (MHz)	Measure Level (dBuV/m)	Reading Level (dBuV)	Over Limit (dB)	Limit (dBuV/m)	Factor (dB)	Type
1	47.460	19.362	4.563	-20.638	40.000	14.799	QP
2	106.630	17.122	4.323	-26.378	43.500	12.799	QP

Note: Measure Level (dBuV/m) = Reading Level (dBuV) + Factor (dB)

Factor (dB) = Cable Loss (dB) + Antenna Factor (dB/m)

Site: AC1	Time: 2014/11/14 - 16:10
Limit: FCC_Part15.209_RE(3m)	Engineer: Roy Cheng
Probe: VULB9162_0.03-8GHz	Polarity: Vertical
EUT: Wireless Selfie Sticks	Power: By Battery
<b>Worst Test Mode: 2DH5 at channel 2441MHz</b>	

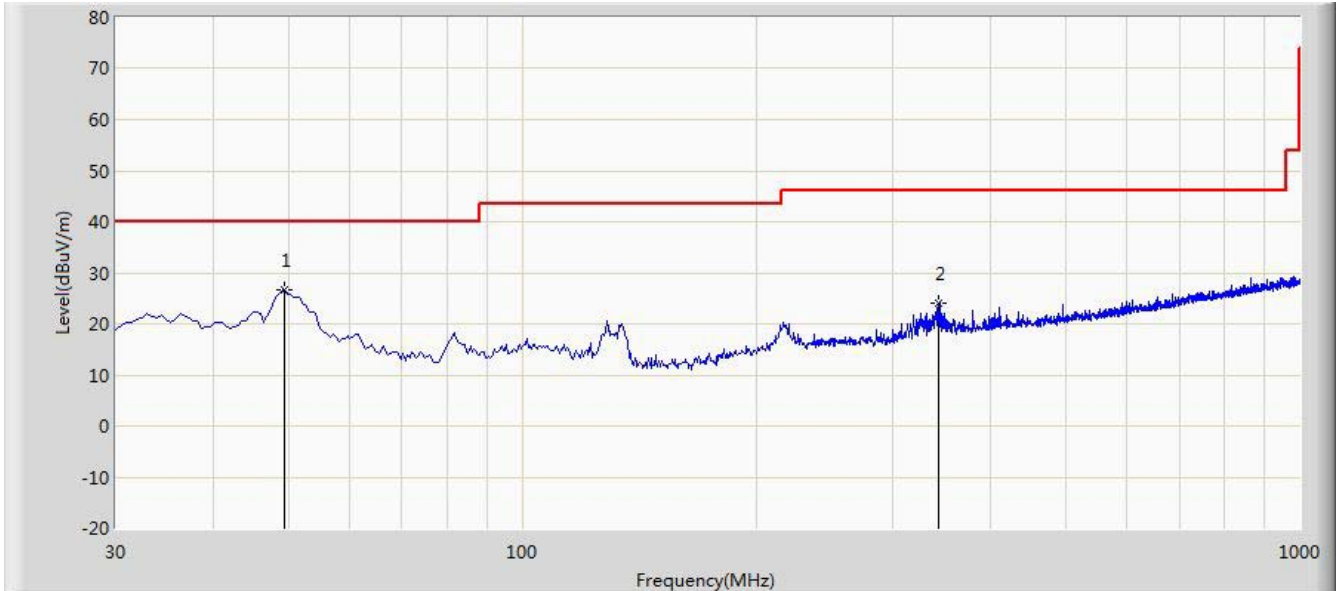

No	Frequency (MHz)	Measure Level (dBuV/m)	Reading Level (dBuV)	Over Limit (dB)	Limit (dBuV/m)	Factor	Type
1	49.400	26.770	12.003	-13.230	40.000	14.767	QP
2	342.825	24.040	8.765	-21.960	46.000	15.275	QP

Note: Measure Level (dBμV/m) = Reading Level (dBμV) + Factor (dB)

Factor (dB) = Cable Loss (dB) + Antenna Factor (dB/m)



Site: AC1	Time: 2014/11/13 - 13:34
Limit: FCC_Part15.209_RE(3m)	Engineer: Roy Cheng
Probe: FMZB1519_0.009-30MHz	Polarity: Face On
EUT: Wireless Selfie Sticks	Power: By Battery

**Note: There is the ambient noise within frequency range 9kHz~30MHz.**

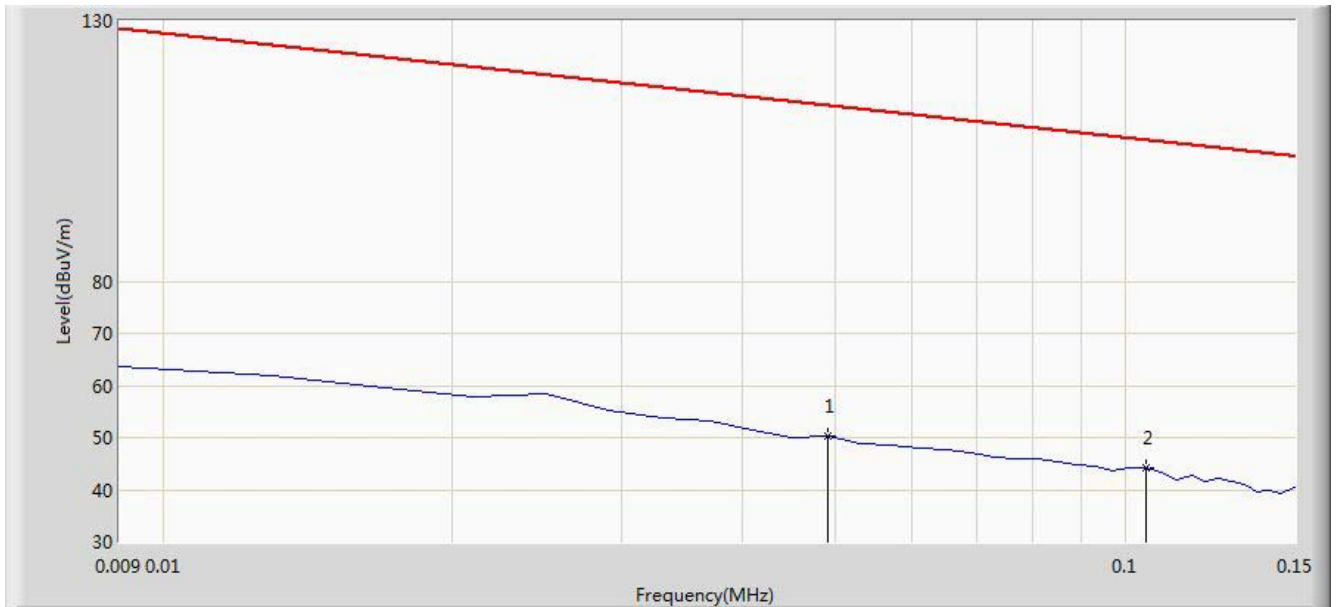

No	Frequency (MHz)	Measure Level (dBuV/m)	Reading Level (dBuV)	Over Limit (dB)	Limit (dBuV/m)	Factor (dB)	Type
1	0.049	50.367	29.861	-63.422	113.789	20.505	QP
2	0.105	44.143	23.996	-63.029	107.173	20.147	QP

Note: Measure Level (dBμV/m) = Reading Level (dBμV) + Factor (dB)

Factor (dB) = Cable Loss (dB) + Antenna Factor (dB/m)

Site: AC1	Time: 2014/11/13 - 13:45
Limit: FCC_Part15.209_RE(3m)	Engineer: Roy Cheng
Probe: FMZB1519_0.009-30MHz	Polarity: Face On
EUT: Wireless Selfie Sticks	Power: By Battery

**Note: There is the ambient noise within frequency range 9kHz~30MHz.**

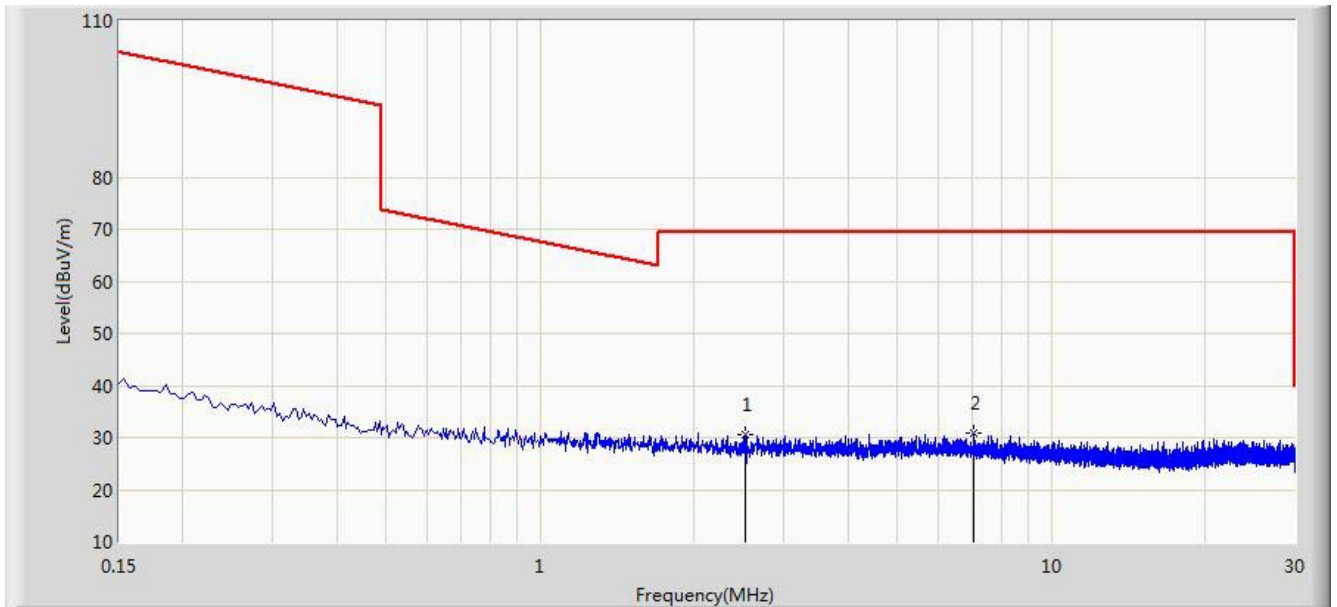

No	Frequency (MHz)	Measure Level (dBuV/m)	Reading Level (dBuV)	Over Limit (dB)	Limit (dBuV/m)	Factor (dB)	Type
1	2.513	30.495	10.336	-39.005	69.500	20.159	QP
2	7.041	30.974	10.579	-38.526	69.500	20.395	QP

Note: Measure Level (dBμV/m) = Reading Level (dBμV) + Factor (dB)

Factor (dB) = Cable Loss (dB) + Antenna Factor (dB/m)

Site: AC1	Time: 2014/11/13 - 13:59
Limit: FCC_Part15.209_RE(3m)	Engineer: Roy Cheng
Probe: BBHA9170_18-40GHz	Polarity: Horizontal
EUT: Wireless Selfie Sticks	Power: By Battery

**Note: There is the ambient noise within frequency range 18GHz~25GHz.**

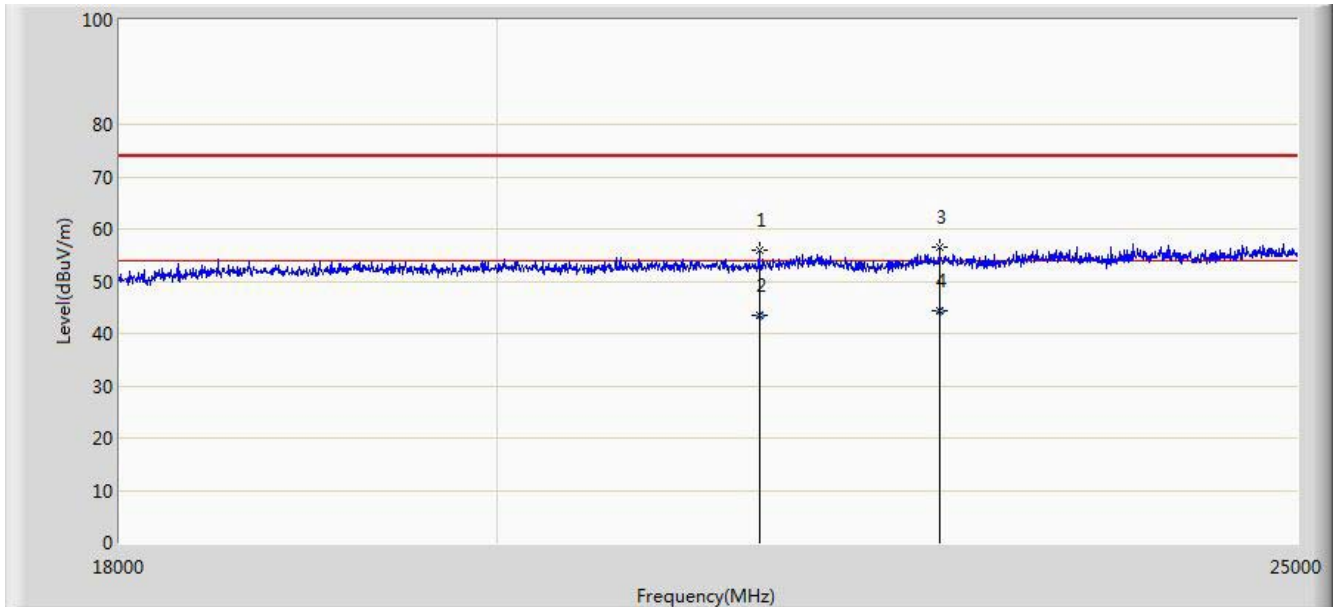

No	Frequency (MHz)	Measure Level (dBuV/m)	Reading Level (dBuV)	Over Limit (dB)	Limit (dBuV/m)	Factor (dB)	Type
1	21517.500	55.869	17.883	-18.131	74.000	37.986	PK
2	21517.650	43.351	5.365	-10.649	54.000	37.986	AV
3	22630.500	56.509	18.223	-17.491	74.000	38.286	PK
4	22630.540	44.310	6.024	-9.690	54.000	38.286	AV

Note: Measure Level (dBuV/m) = Reading Level (dBuV) + Factor (dB)

Factor (dB) = Cable Loss (dB) + Antenna Factor (dB/m)

Site: AC1	Time: 2014/11/13 - 14:05
Limit: FCC_Part15.209_RE(3m)	Engineer: Roy Cheng
Probe: BBHA9170_18-40GHz	Polarity: Vertical
EUT: Wireless Selfie Sticks	Power: By Battery

**Note: There is the ambient noise within frequency range 18GHz~25GHz.**

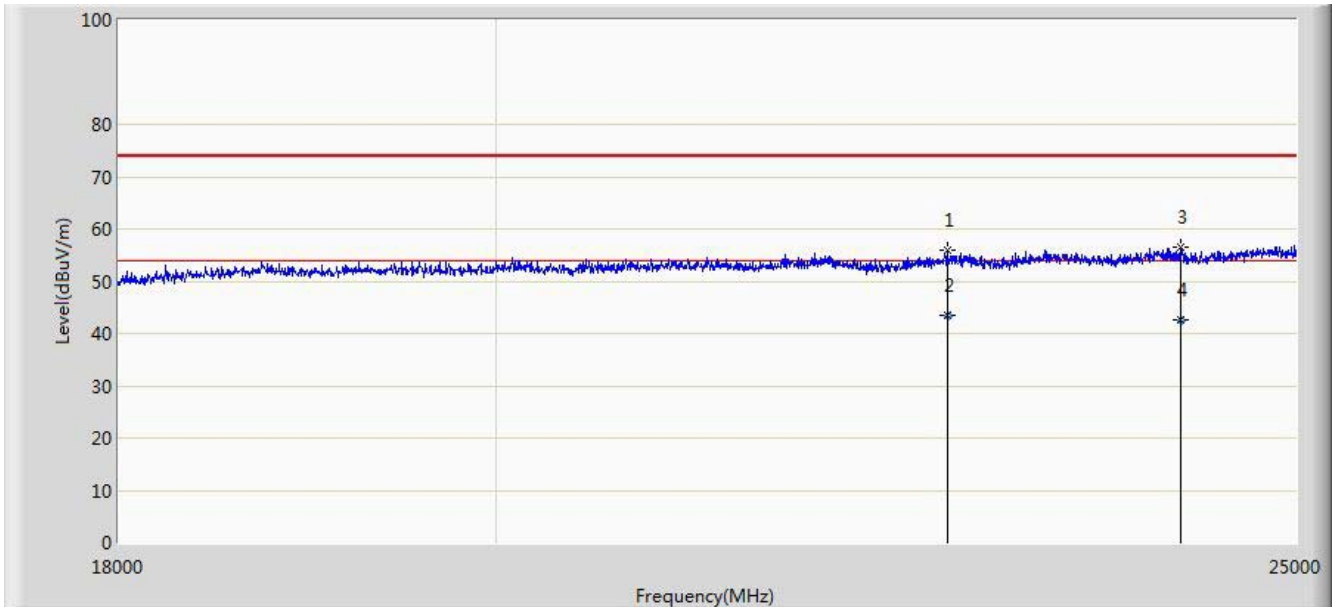

No	Frequency (MHz)	Measure Level (dBuV/m)	Reading Level (dBuV)	Over Limit (dB)	Limit (dBuV/m)	Factor (dB)	Type
1	22686.500	55.811	17.457	-18.189	74.000	38.354	PK
2	22686.540	43.598	5.244	-10.402	54.000	38.354	AV
3	24205.500	56.430	17.607	-17.570	74.000	38.823	PK
4	24205.658	42.518	3.695	-11.482	54.000	38.823	AV

Note: Measure Level (dBuV/m) = Reading Level (dBuV) + Factor (dB)

Factor (dB) = Cable Loss (dB) + Antenna Factor (dB/m)

## 7.10. Radiated Restricted Band Edge Measurement

### 7.10.1. Test Result

Site: AC1	Time: 2014/11/14 - 09:48
Limit: FCC_Part15.209_RE(3m)	Engineer: Roy Cheng
Probe: BBHA9120D_1-18GHz	Polarity: Horizontal
EUT: Wireless Selfie Sticks	Power: By Battery
<b>Worst Test Mode:</b> Transmit at channel 2402MHz by DH5	

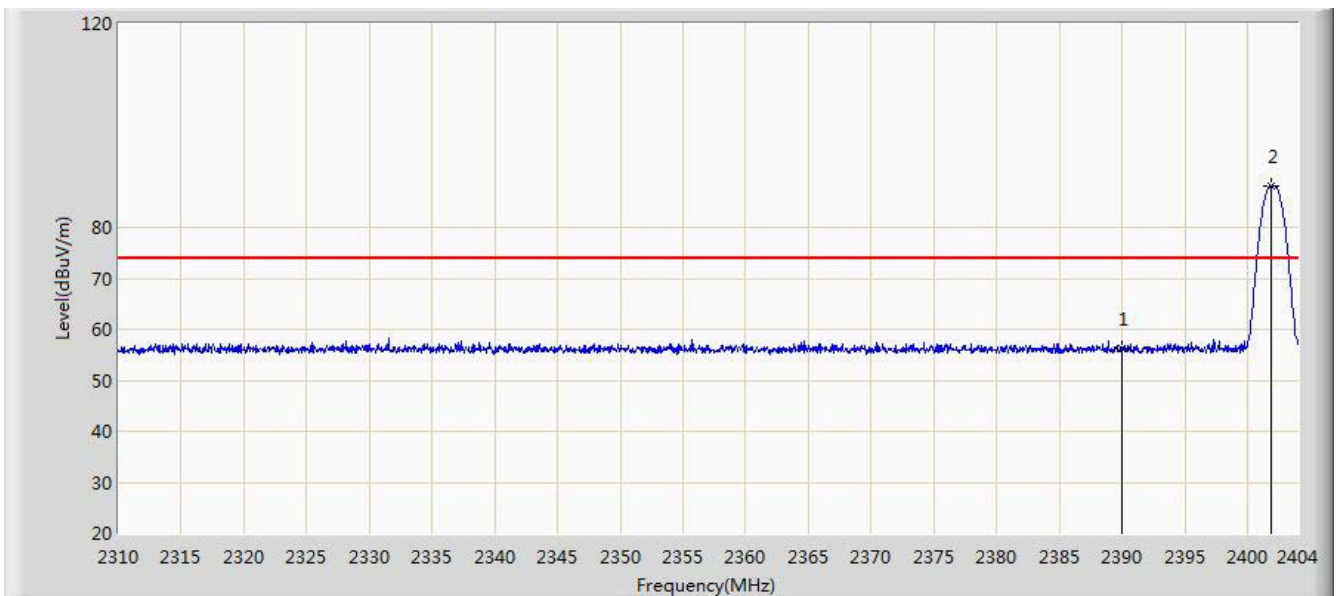

No	Frequency (MHz)	Measure Level (dBuV/m)	Reading Level (dBuV)	Over Limit (dB)	Limit (dBuV/m)	Factor (dB)	Type
1	2390.000	56.366	25.682	-17.634	74.000	30.684	PK
2	2401.885	88.027	57.366	N/A	N/A	30.661	PK

Note: Measure Level (dB $\mu$ V/m) = Reading Level (dB $\mu$ V) + Factor (dB)

Factor (dB) = Cable Loss (dB) + Antenna Factor (dB/m)

Site: AC1	Time: 2014/11/14 - 09:58
Limit: FCC_Part15.209_RE(3m)	Engineer: Roy Cheng
Probe: BBHA9120D_1-18GHz	Polarity: Horizontal
EUT: Wireless Selfie Sticks	Power: By Battery
<b>Worst Test Mode:</b> Transmit at channel 2402MHz by DH5	



No	Frequency (MHz)	Measure Level (dBuV/m)	Reading Level (dBuV)	Over Limit (dB)	Limit (dBuV/m)	Factor (dB)	Type
1	2390.000	43.126	12.442	-10.874	54.000	30.684	AV
2	2402.073	77.481	46.820	N/A	N/A	30.661	AV

Note: Measure Level (dBμV/m) = Reading Level (dBμV) + Factor (dB)

Factor (dB) = Cable Loss (dB) + Antenna Factor (dB/m)

Site: AC1	Time: 2014/11/14 - 09:58
Limit: FCC_Part15.209_RE(3m)	Engineer: Roy Cheng
Probe: BBHA9120D_1-18GHz	Polarity: Vertical
EUT: Wireless Selfie Sticks	Power: By Battery
<b>Worst Test Mode:</b> Transmit at channel 2402MHz by DH5	

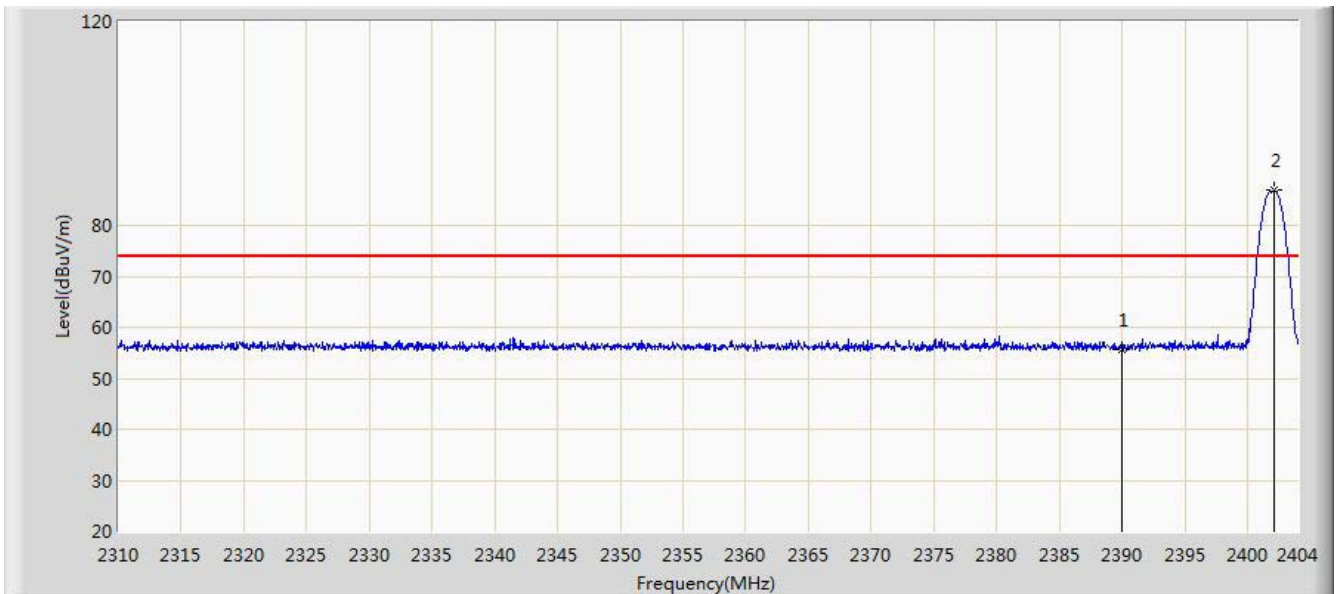

No	Frequency (MHz)	Measure Level (dBuV/m)	Reading Level (dBuV)	Over Limit (dB)	Limit (dBuV/m)	Factor (dB)	Type
1	2390.000	55.778	25.094	-18.222	74.000	30.684	PK
2	2402.073	86.861	56.200	N/A	N/A	30.661	PK

Note: Measure Level (dB $\mu$ V/m) = Reading Level (dB $\mu$ V) + Factor (dB)

Factor (dB) = Cable Loss (dB) + Antenna Factor (dB/m)

Site: AC1	Time: 2014/11/14 - 10:01
Limit: FCC_Part15.209_RE(3m)	Engineer: Roy Cheng
Probe: BBHA9120D_1-18GHz	Polarity: Vertical
EUT: Wireless Selfie Sticks	Power: By Battery
<b>Worst Test Mode:</b> Transmit at channel 2402MHz by DH5	



No	Frequency (MHz)	Measure Level (dBuV/m)	Reading Level (dBuV)	Over Limit (dB)	Limit (dBuV/m)	Factor (dB)	Type
1	2390.000	43.133	12.449	-10.867	54.000	30.684	AV
2	2401.979	77.000	46.339	N/A	N/A	30.662	AV

Note: Measure Level (dB $\mu$ V/m) = Reading Level (dB $\mu$ V) + Factor (dB)

Factor (dB) = Cable Loss (dB) + Antenna Factor (dB/m)



Site: AC1	Time: 2014/11/14 - 11:15
Limit: FCC_Part15.209_RE(3m)	Engineer: Roy Cheng
Probe: BBHA9120D_1-18GHz	Polarity: Horizontal
EUT: Wireless Selfie Sticks	Power: By Battery
<b>Worst Test Mode:</b> Transmit at channel 2480MHz by 2DH5	

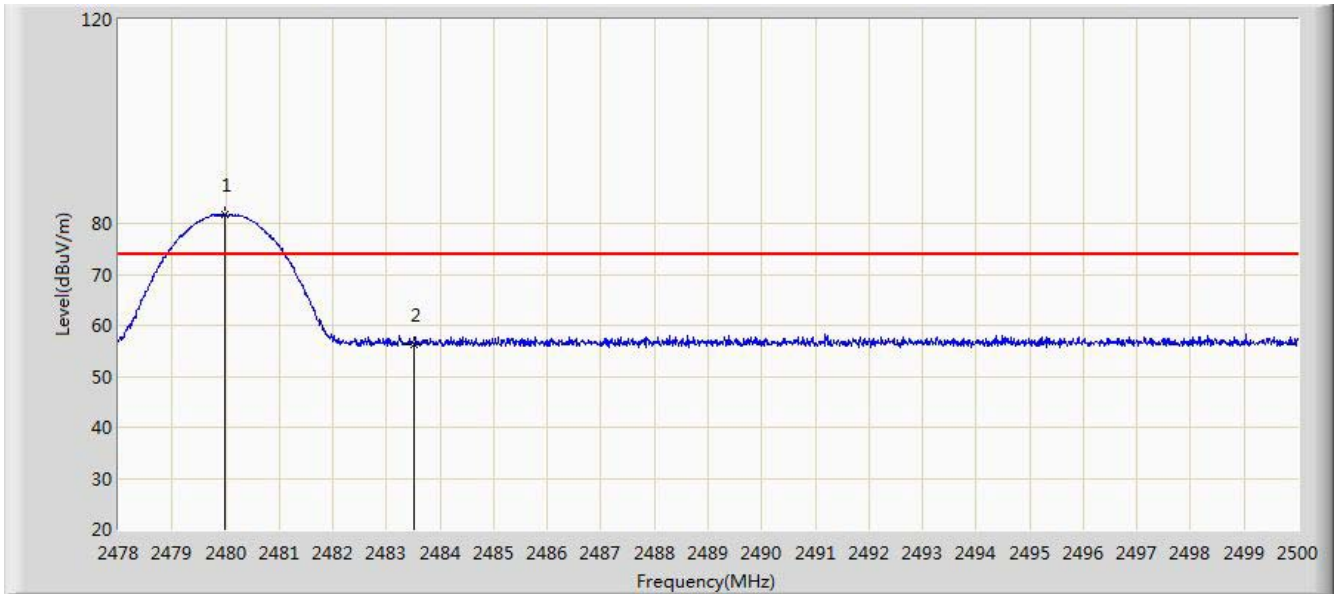

No	Frequency (MHz)	Measure Level (dBuV/m)	Reading Level (dBuV)	Over Limit (dB)	Limit (dBuV/m)	Factor (dB)	Type
1	2479.980	81.760	51.098	N/A	N/A	30.662	PK
2	2483.500	56.371	25.698	-17.629	74.000	30.673	PK

Note: Measure Level (dB $\mu$ V/m) = Reading Level (dB $\mu$ V) + Factor (dB)

Factor (dB) = Cable Loss (dB) + Antenna Factor (dB/m)

Site: AC1	Time: 2014/11/14 - 11:18
Limit: FCC_Part15.209_RE(3m)	Engineer: Roy Cheng
Probe: BBHA9120D_1-18GHz	Polarity: Horizontal
EUT: Wireless Selfie Sticks	Power: By Battery
<b>Worst Test Mode:</b> Transmit at channel 2480MHz by 2DH5	

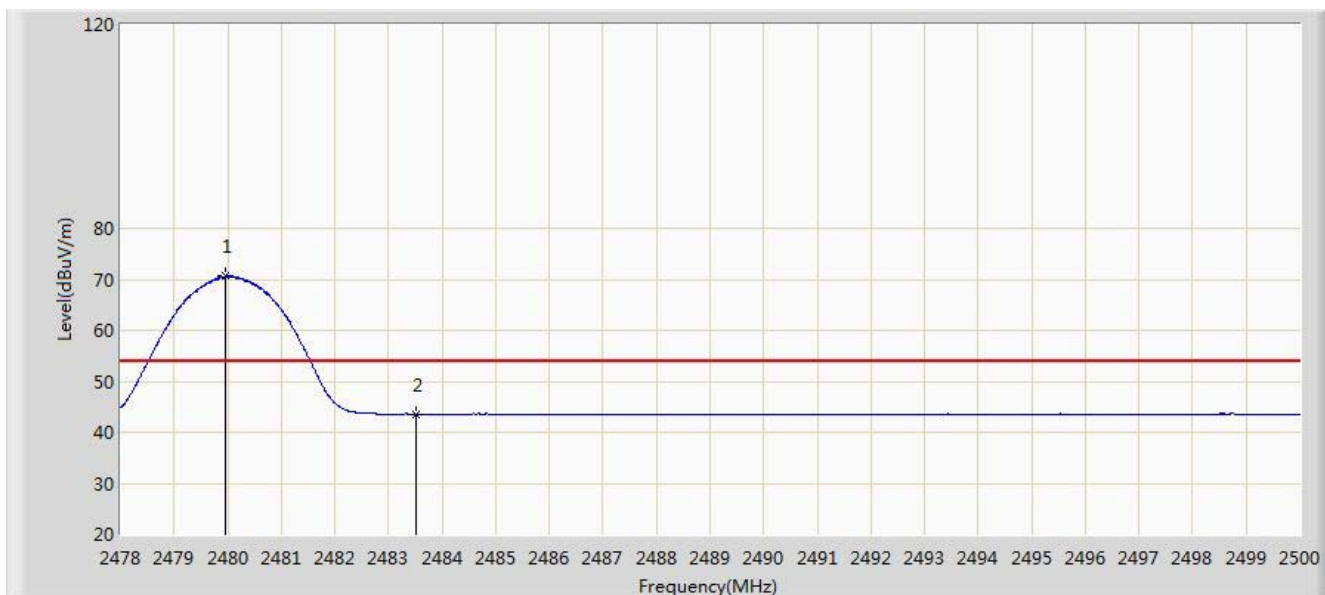

No	Frequency (MHz)	Measure Level (dBuV/m)	Reading Level (dBuV)	Over Limit (dB)	Limit (dBuV/m)	Factor (dB)	Type
1	2479.969	70.600	39.938	N/A	N/A	30.662	AV
2	2483.500	43.599	12.926	-10.401	54.000	30.673	AV

Note: Measure Level (dB $\mu$ V/m) = Reading Level (dB $\mu$ V) + Factor (dB)

Factor (dB) = Cable Loss (dB) + Antenna Factor (dB/m)

Site: AC1	Time: 2014/11/14 - 11:19
Limit: FCC_Part15.209_RE(3m)	Engineer: Roy Cheng
Probe: BBHA9120D_1-18GHz	Polarity: Vertical
EUT: Wireless Selfie Sticks	Power: By Battery
<b>Worst Test Mode:</b> Transmit at channel 2480MHz by 2DH5	

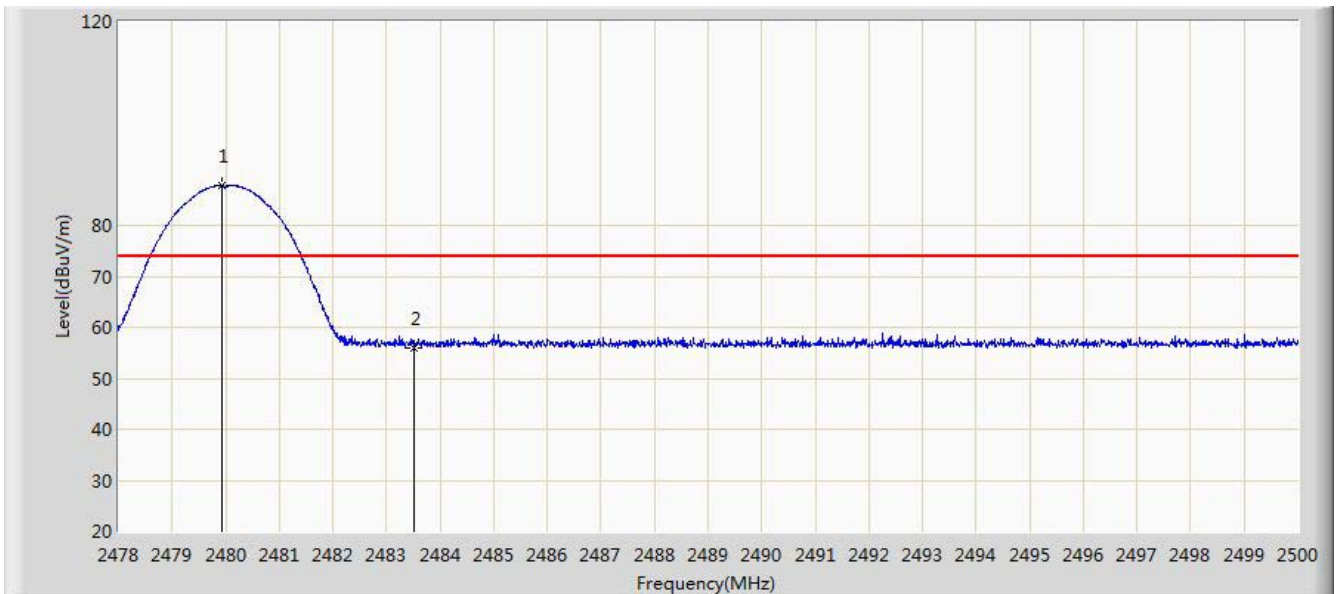

No	Frequency (MHz)	Measure Level (dBuV/m)	Reading Level (dBuV)	Over Limit (dB)	Limit (dBuV/m)	Factor (dB)	Type
1	2479.936	87.699	57.037	N/A	N/A	30.662	PK
2	2483.500	56.045	25.372	-17.955	74.000	30.673	PK

Note: Measure Level (dB $\mu$ V/m) = Reading Level (dB $\mu$ V) + Factor (dB)

Factor (dB) = Cable Loss (dB) + Antenna Factor (dB/m)

Site: AC1	Time: 2014/11/14 - 11:22
Limit: FCC_Part15.209_RE(3m)	Engineer: Roy Cheng
Probe: BBHA9120D_1-18GHz	Polarity: Vertical
EUT: Wireless Selfie Sticks	Power: By Battery
<b>Worst Test Mode:</b> Transmit at channel 2480MHz by 2DH5	

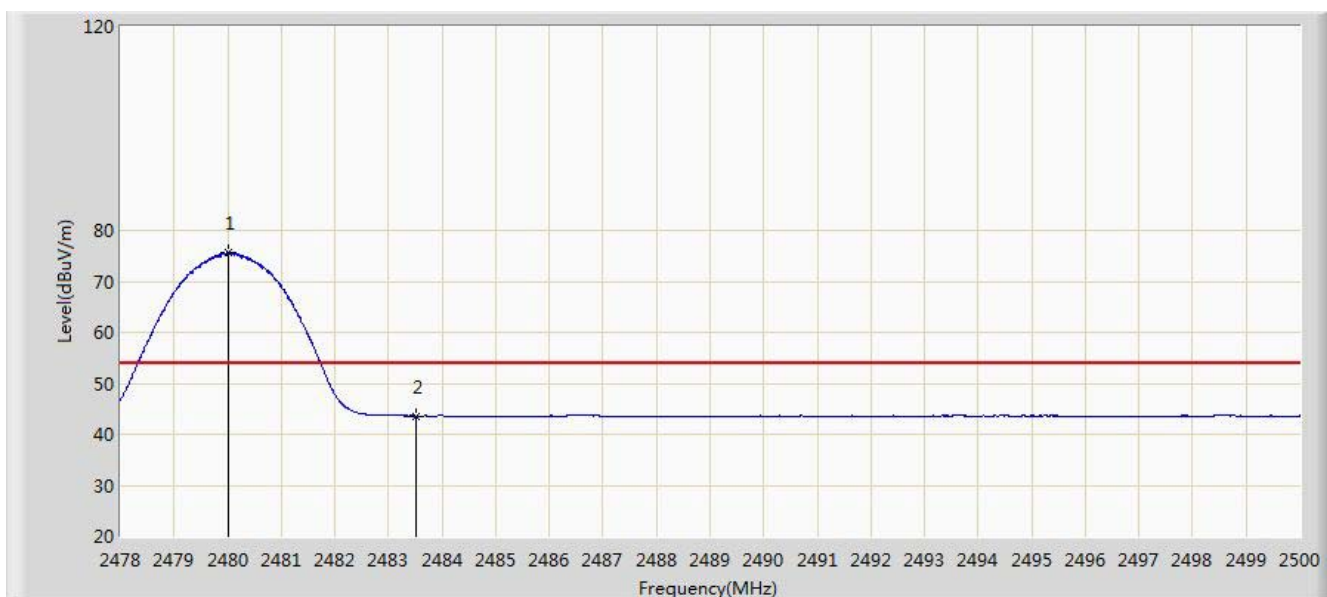

No	Frequency (MHz)	Measure Level (dBuV/m)	Reading Level (dBuV)	Over Limit (dB)	Limit (dBuV/m)	Factor (dB)	Type
1	2480.002	75.540	44.878	N/A	N/A	30.662	AV
2	2483.500	43.621	12.948	-10.379	54.000	30.673	AV

Note: Measure Level (dB $\mu$ V/m) = Reading Level (dB $\mu$ V) + Factor (dB)

Factor (dB) = Cable Loss (dB) + Antenna Factor (dB/m)

## 7.11. AC Conducted Emissions Measurement

### 7.11.1. Test Limit

FCC Part 15 Subpart C Paragraph 15.207 Limits		
Frequency (MHz)	QP (dB $\mu$ V)	Average (dB $\mu$ V)
0.15 - 0.50	66 - 56	56 - 46
0.50 - 5.0	56	46
5.0 - 30	60	50

Note 1: The lower limit shall apply at the transition frequencies.

Note 2: The limit decreases linearly with the logarithm of the frequency in the range 0.15MHz to 0.5MHz.

### 7.11.2. Test Setup

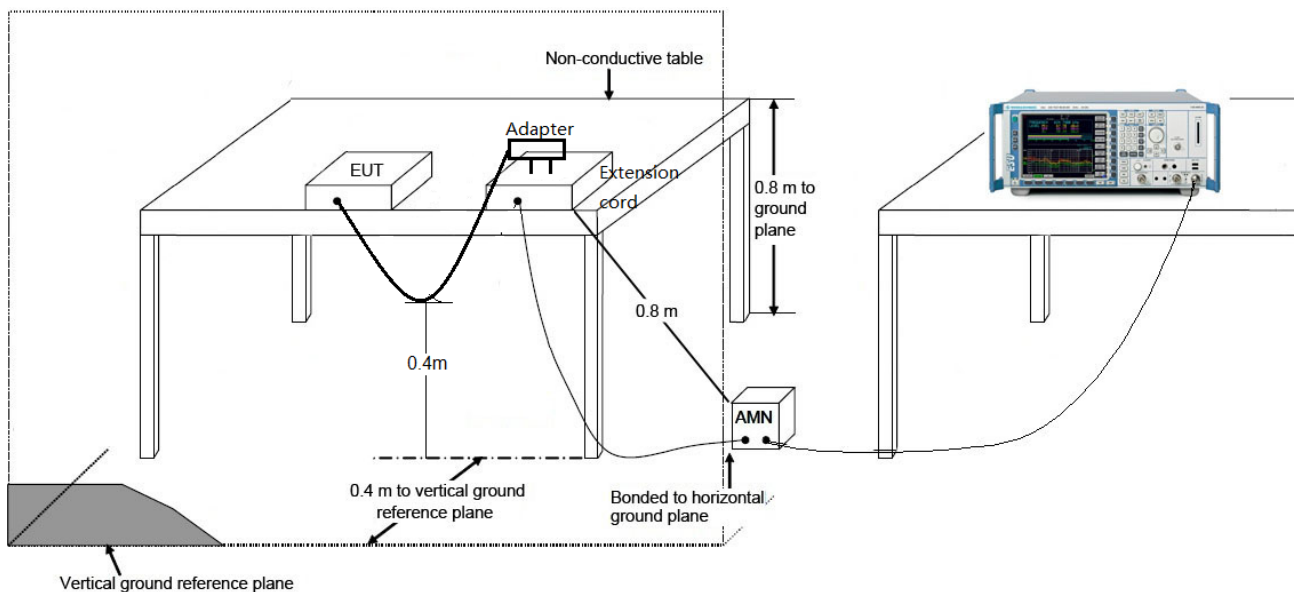

### 7.11.3. Test Result

Site: SR2	Time: 2014/11/10 - 20:21
Limit: FCC_Part15.207_CE_AC Power	Engineer: Roy Cheng
Probe: ENV216_101683_Filter On	Polarity: Line
EUT: Wireless Selfie Sticks	Power: AC 120V/60Hz
Note: Mode1	

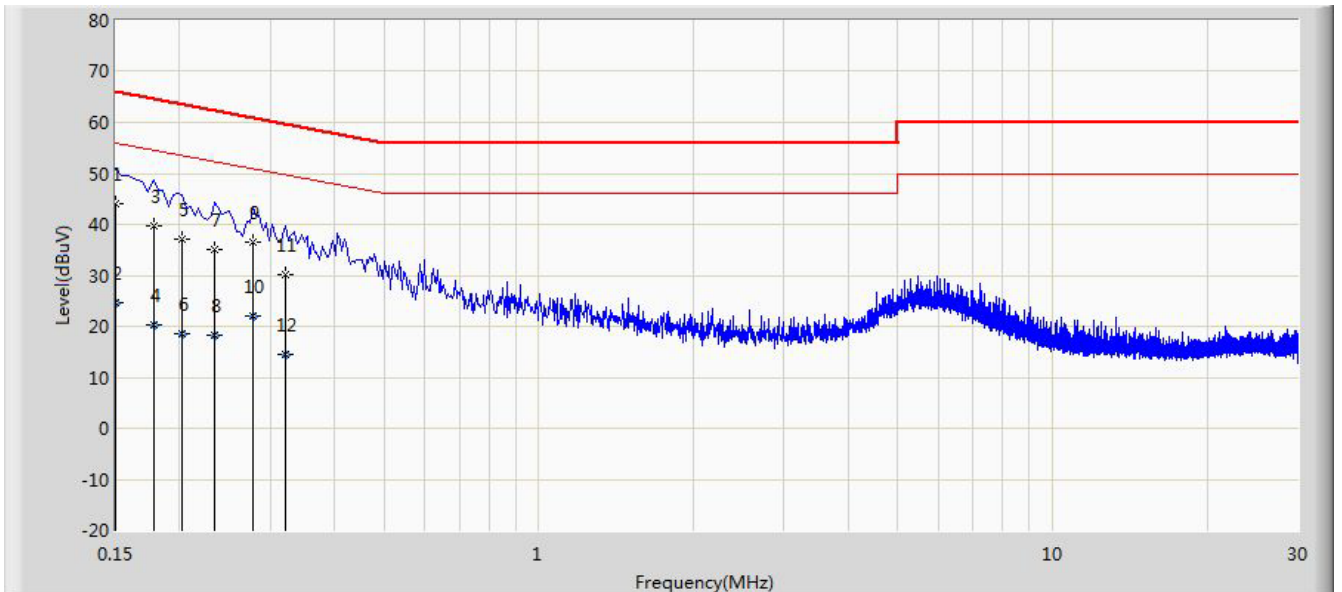

No	Frequency (MHz)	Measure Level (dBuV)	Reading Level (dBuV)	Over Limit (dB)	Limit (dBuV)	Factor (dB)	Type
1	0.150	44.019	32.851	-21.981	66.000	11.168	QP
2	0.150	24.714	13.545	-31.286	56.000	11.168	AV
3	0.178	39.802	29.744	-24.776	64.578	10.058	QP
4	0.178	20.161	10.103	-34.417	54.578	10.058	AV
5	0.202	37.080	27.087	-26.448	63.528	9.993	QP
6	0.202	18.532	8.539	-34.996	53.528	9.993	AV
7	0.234	35.053	25.102	-27.254	62.307	9.951	QP
8	0.234	18.168	8.218	-34.138	52.307	9.951	AV
9	0.278	36.583	26.596	-24.293	60.875	9.986	QP
10	0.278	22.006	12.020	-28.869	50.875	9.986	AV
11	0.322	30.076	20.054	-29.579	59.655	10.022	QP
12	0.322	14.488	4.466	-35.167	49.655	10.022	AV

Note: Measure Level (dB $\mu$ V) = Reading Level (dB $\mu$ V) + Factor (dB)

Factor (dB) = Cable Loss (dB) + LISN Factor (dB)

Site: SR2	Time: 2014/11/10 - 20:29
Limit: FCC_Part15.207_CE_AC Power	Engineer: Roy Cheng
Probe: ENV216_101683_Filter On	Polarity: Neutral
EUT: Wireless Selfie Sticks	Power: AC 120V/60Hz
Note: Mode1	

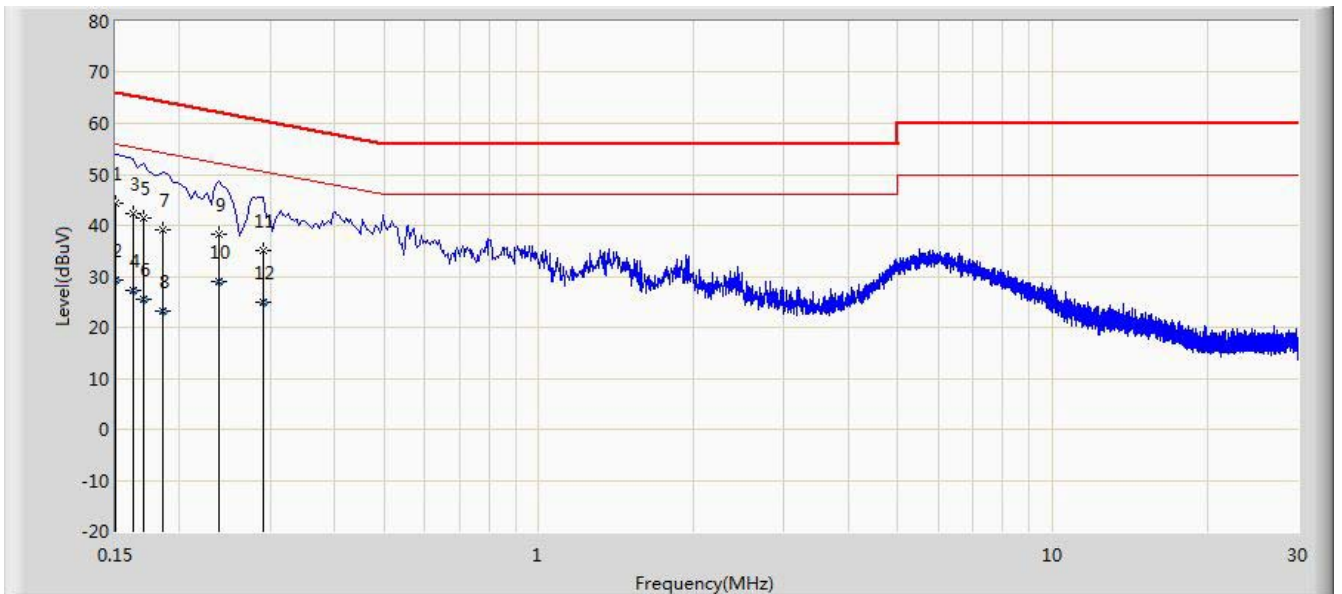

No	Frequency (MHz)	Measure Level (dBuV)	Reading Level (dBuV)	Over Limit (dB)	Limit (dBuV)	Factor (dB)	Type
1	0.150	44.464	33.322	-21.536	66.000	11.142	QP
2	0.150	29.415	18.273	-26.585	56.000	11.142	AV
3	0.162	42.200	32.121	-23.161	65.361	10.078	QP
4	0.162	27.171	17.092	-28.190	55.361	10.078	AV
5	0.170	41.405	31.341	-23.555	64.960	10.064	QP
6	0.170	25.580	15.516	-29.380	54.960	10.064	AV
7	0.186	39.063	29.028	-25.150	64.213	10.035	QP
8	0.186	23.082	13.047	-31.131	54.213	10.035	AV
9	0.238	38.371	28.379	-23.795	62.166	9.992	QP
10	0.238	29.051	19.060	-23.114	52.166	9.992	AV
11	0.290	35.003	24.972	-25.522	60.524	10.030	QP
12	0.290	24.830	14.800	-25.694	50.524	10.030	AV

Note: Measure Level (dBμV) = Reading Level (dBμV) + Factor (dB)

Factor (dB) = Cable Loss (dB) + LISN Factor (dB)

## 8. CONCLUSION

The data collected relate only the item(s) tested and show that the **Wireless Selfie Sticks FCC ID: 2ACZWBT004** is in compliance with Part 15C of the FCC Rules.

————— The End —————