

Mars Laser RTK

User Guide



Corporate office

ComNav Technology Ltd.

Building 2, No.618 Chengliu Middle Road, 201801 Shanghai, China

Tel: +86 21 64056796

Fax: +86 21 54309582

Website:<http://www.comnavtech.com>

E-mail:support@comnavtech.com

Trademark notice

© 2022 ComNav Technology Ltd. All rights reserved.

SinoGNSS is the official trademark of ComNav Technology Ltd., registered in People's Republic of China, EU, USA and Canada.

FCC Notice

SinoGNSS Mars comply with the limits for a Class B digital device, pursuant to the Part 15 of the FCC rules when it is used in the Portable Mode.

Operation is subject to the following two conditions:

- (1) This device may not cause harmful interference;
- (2) It must accept any interference received, including interference that may cause undesired operation.

Copyright Notice

This is the V1.0 (August, 2022) revision of the Mars User Guide. It cannot be copied or translated into any language without the written permission of ComNav Technology Ltd.

Technical Assistance

If you have any question and can't find the answer in this manual, please contact your local dealer from which you purchased the Mars. Alternatively, request technical support from ComNav Technology Website: www.comnavtech.com or technical support email: support@comnavtech.com. Your feedback about this Guide will help us to improve it with future revisions.

Safety Information

Before using the receiver, please make sure that you have read and understood this User Guide, as well as the safety requirements.

- Connect your devices strictly based on this User Guide
- Install the GNSS receiver in a location that minimizes vibration and moisture
- Avoid falling to ground, or colliding with other items

- Keep a sound ventilation environment
- Change the cable if damaged

Related Regulations

The receiver contains integral Bluetooth® wireless technology. Regulations regarding the use of the datalink vary greatly from country to country. In some countries, the unit can be used without obtaining an end-user license. But in some countries the administrative permissions are required. For license information, please consult your local dealer.

Use and Care

The receiver can withstand the rough treatment that typically occurs in the field. However, the receiver is high-precision electronic equipment and should be treated with reasonable care.

Warning and Caution

An absence of specific alerts does not mean that there are no safety risks involved. A Warning or Caution information is intended to minimize the risk of personal injury and/or damage to the equipment.

WARNING- A Warning alerts you to a potential risk of serious injury to your person and/or damage to the equipment, because of improper operations or wrong settings of the equipment.

CAUTION- A Caution alerts you to a possible risk of damage to the equipment and/or data loss.

Warranty Notice

ComNav Technology does not warranty devices damage because of force majeure (lighting, high voltage or collision).

ComNav Technology does not warranty the disassembled devices.

Contents

1. Introduction	1
1.1. About the receiver	1
1.2. Receiver features	1
1.3. Mars parts list	1
1.3.1 Basic Supply kit	2
1.3.2 Optional Datalink kit	4
1.3.3 Transport Cases	5
2. Setting up the receiver	6
2.1. Environmental requirements	6
2.2. Laser Specification	6
2.3. Front panel	6
2.4. Lower housing	7
2.5. Power supply	7
2.5.1 Internal batteries	7
2.5.2 External Power Supply	8
2.5.3 Charge Battery via Mars	8
2.6 Pole-mounted setup	9
3. General Operation	9
3.1 Button functions	9
3.2 LED behavior	10
3.3 Receiver Web GUI interface	11
3.3.1 Checking the receiver status	12
3.3.2 Configuration	15
3.3.3 Receiver Management	20
4. Static survey	27
4.1 Receiver Configuration	27
4.2 Static Data Collection	28
4.3 Static Data Download	28
5. Real-Time Kinematic Survey (RTK)	31
5.1 Installation of Survey Master	31
5.2 Wizard function in Survey Master	31
5.3 Start a New Project	32
5.4 Bluetooth connection	34
5.5 Internal Radio Mode	36
5.5.1 Start Base Station by Survey Master	36
5.5.2 Start Rover Station by Survey Master	38
5.6 External radio mode	39
5.7 PDA CORS Mode	41

5.8 Internal GPRS Mode	42
5.8.1 Point to Point/Points mode (P to PS mode)	42
5.8.2 Internal 4G Ntrip client mode	43
6. Basic Survey Functions	44
6.1 Topo survey	44
6.1.1 Survey settings	46
6.1.2 Tilt survey	47
6.2 Auto survey/Area survey	49
6.3 Stake points/lines	50
6.4 PPK	52
6.5 Site calibration/Grid Shift	54
6.5.1 Site calibration	54
6.5.2 Grid Shift	56
6.6 COGO	56
7. Data Export/Import	57
7.1 Import	58
7.2 Export	59
7.3 Import Basemap	60
8. Export Result	61
8.1 NMEA 0183 output	61
8.2 Register Mars via Survey Master	62
➤ Register function	62
9. Firmware Upgrade	63
Appendix A: 7-Pin Lemo definition	64
Appendix B: Physical Parameter of Modules inside of Mars	65

1. Introduction

The SinoGNSS Mars User Guide is aimed to help you get familiar with the Mars laser RTK and start your project effectively. We highly recommend you to read this manual before surveying, even you have used other GNSS receivers before.

1.1. About the receiver

With SinoGNSS® Quantum™ algorithm, Mars can be applied in RTK mode with all GNSS constellations. It has ultra-small size and strong anti-interference ability to make it possible to work even in harsh environments. It is the ideal RTK/GNSS product for surveyors.

1.2. Receiver features

The SinoGNSS® Mars key features:







- Ultra small and super light
 - Size: 15.5 cm × 7.3 cm
 - Weight: 1.5kg with two batteries
- 1590 channels of simultaneously tracked satellite signals
- Increased measurement traceability with SinoGNSS® Quantum™ algorithm technology
- Able-free Bluetooth wireless technology
- 2 LEDs, indicating Satellites Tracking and RTK Corrections data
- 1 OLED Display and 2 Function buttons
- IP67 waterproof
- Calibration-free IMU integrated for Tilt Survey
- Up to 60°tilt with 2.5 cm accuracy
- Integrated Laser sensor
- Support SBAS and PPP service
- Support NFC Fast Connection
- Support long baseline E-RTK™ (Beidou B3 signal is included in RTK calculate engine)





1.3. Mars parts list

This section provides overall Mars parts list, including basic supplies and customized kits based on your requirements.



1.3.1 Basic Supply kit

SinoGNSS® Mars Basic Supply kit contains one receivers and related accessories

Item	Picture
1*Kits Mars Receivers	
1*GNSS Connector	
1*7-pin Lemo to RS232 Cable	
1* 7-pin Lemo to USB Cable	
External Power Cable	
1* Whip Antenna (UHF)	
1*2m-Range Pole with yellow bag	







<p>2* Lithium-ion Battery</p>	
<p>1* Battery Charger</p>	
<p>R550 Controller</p>	
<p>Controller Battery, Charger and Cable</p>	
<p>Controller Bracket</p>	

Optional accessories:

<p>Double Bubbles Tribrach with High Adapter</p>	
<p>1* 30cm Extension bar</p>	

1.3.2 Optional Datalink kit

This kit is necessary for long distance radio communication, shown in the following figures:

Item	Picture
External Radio CDL7	
2-pin Lemo Power Cable	
7-pin Lemo Data Cable	
N-Type to TNC Convertor	
N-type to N-type Antenna Cable	
N-Type Radio Antenna	

1.3.3 Transport Cases

Standard transport case is designed for containing basic supply kit of one SinoGNSSoR Mars GNSS Receiver.



Base



Rover

The optional choice is provided to have capacity of two kits of Mars receivers



2. Setting up the receiver

This chapter provides general information on environmental requirements, setup, power supply and connection of the Mars.

2.1. Environmental requirements

To keep the receiver with a reliable performance, it is better to use the receiver in safe environmental conditions:

- Operating temperature: -20°C to 50°C
- Storage temperature: -30°C to 60°C
- Out of corrosive fluids and gases
- With a clear view of sky

2.2. Laser Specification

To keep the laser with a reliable performance, It is better to use Mars in the conditions that meet the laser specifications:

- Range: 15m
- Accuracy(room temperature): (3-5)mm + 1ppm
- Measuring Frequency: Classic Value: 3Hz
- Maximum Value: 5Hz
- Laser Injection Power: 0.9mW to 1.5mW
- Working Temperature: -20°C to +50°C
- Storage Temperature: -30°C to +60°C

2.3. Front panel

Receiver front panel contains 5 indicator LEDs, Power button and Record button. The indicator LEDs show the status of differential, satellite tracking, WIFI/GPRS and battery. For detailed information, see [chapter 3.3](#).



2.4. Lower housing

Receiver lower housing contains a serial port, UHF radio antenna connector, two removable battery compartments (the SIM card slot is located in compartment A), and a threaded insert.



2.5. Power supply

Mars supports two internal batteries and external power input.

2.5.1 Internal batteries

The receiver is equipped with two rechargeable Lithium-ion batteries, which can be removed for charging. The Mars receiver adopts the hot swap battery design that provides you an effective survey workflow. The internal batteries typically provide about 25-hour operating time as a rover, about 19-hour operating time if operated as a base station with internal UHF Tx (transmit at 1-2 watts). However, this operating time varies based on environmental conditions

● Battery Safety

Charge and use the battery only in strict accordance with the instructions below:

- Do not use or charge the battery if it appears to be damaged. Signs of damage include, but are not limited to, discoloration, warping, and leaking battery fluid.
- Do not expose the battery to fire, high temperature, or direct sunlight.
- Do not immerse the battery in water.
- Do not use or store the battery inside a vehicle during hot weather.
- Do not drop or puncture the battery.
- Do not open the battery or short-circuit its contacts.

- **Charging the Lithium-ion Battery**

Although a dual battery charge is provided, the lithium-ion battery is supplied partially charged. To charge the battery, first remove the battery from the receiver, and then place it in the battery charger, which is connected to AC power. Please obey the following instructions when charging your batteries:

- Charge the battery completely before using it for the first time.
- Fully charge takes approximately 6 hours per battery at room temperature.
- If the battery has been stored for a long time, charge it before your field work.
- Re-charge the battery at least every three months if it is to be stored for long time.

- **Storage of the Lithium-ion Battery**

- Do not keep batteries inside the receiver if the receiver not used for long time.
- Keep batteries in dry conditions.
- Take out the batteries from receiver for shipment.

- **Dispose of the Lithium-ion Battery**

- Discharge a Lithium-ion battery before dispose of it.
- Dispose of batteries is an environmentally sensitive manner, and adhere to any local and national regulations concerning battery disposing or recycling.

WARNING – Do not damage the rechargeable Lithium-ion battery. A damaged battery can cause an explosion or fire, and can result in personal injury and/or property damage.

2.5.2 External Power Supply

The receiver is connected to an external power supply through a Type-C cable, and make sure that use an external power supply with the correct voltage of Mars, such as a 5-9V power pack. Over-voltage function cannot protect your Mars if reverse connection.



Tip: The power consumption will be increasing if the base station transmits correction data through internal UHF in the RTK mode; therefore, we strongly suggest using external power (7-28 volt DC) for the base station

2.5.3 Charge Battery via Mars

Mars GNSS Receiver can work as a charger, it means you can charge batteries directly if the charger not by your side.

- Power off Mars receiver with batteries inside;
- Connect Mars receiver to 12V external power with serial cable;

- Receiver will charge the battery from Side B to Side A, the red power led will flashing during charging and will off when battery full.



2.6 Pole-mounted setup

To mount the receiver on a range pole as the figure shown below:



- Thread the receiver onto the range pole
- Mount the controller bracket to the pole
- Install the controller into the bracket

Tip: Do not tightly clamp the controller on the Range Pole.

3. General Operation

This chapter introduces all controls for the general operation, including button functions and all LED behaviors on the front panel.

3.1 Button functions

To turn off the receiver, long press the button for 3-4 seconds until all LEDs off.

There are two buttons on the front panel, power button and record button.

- **Power button:**

Press the power button for about 1 second to turn on the receiver;

To turn off the receiver, long press the button for 3-4 seconds until all LEDs off.

- **Record button:**

Switch to static mode: Long press the record button for about 2 seconds, release immediately when hearing beep from receiver;

Switch to RTK mode: press the button until Raw Data recording LED off.

3.2 LED behavior

The LEDs on the front panel indicate receiver working status. Generally, a lit or slowly flashing indicates normal operation, and an unlit LED indicates that no operation is occurring. The following table define each possible LED state:

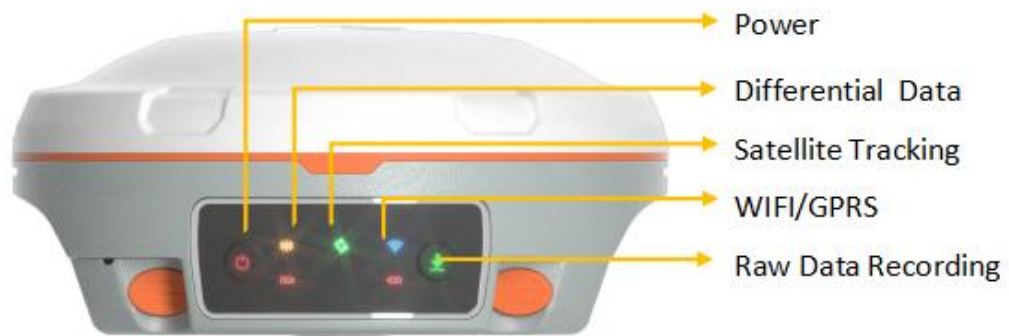

LEDs	States	Description
Power	Lit	Enough power
	Flashing	Low power
Differential Data	Flashes once per second	Receiving/transmitting differential data
Satellite Tracking	Fast flashing/ Flashes 1 time every 5 seconds	No satellite received
	Flashes N times every 5 seconds	Received N satellite signals
Internal 4G and WIFI	Flashes once per second	GPRS function is working
	Flashes once per five- second	WIFI is working
Raw Data Recording	Flashes according to the selected sample interval	1) Sample interval varies from 20Hz to 60s. 2) Flashing 1/s simultaneously with differential light if internal memory is run off

Power LED:

Power supply: 1) Two power LEDs are on if using the external power supply; 2) Only power LED of working battery will be on if using the internal battery.

Low battery: 1) Power LED will flash with beep only with one battery; 2) if with two batteries, the power LED of low battery will flash, and swapped to another battery when it is run off.

3.3 Receiver Web GUI interface

Step 1: Connect Wi-Fi of Mars receiver

Turn on the Mars GNSS receiver and wait for the Mars serial number to appear under the available Wi-Fi networks on your smart phone or office computer.

For example, Mars-M11LXXXXX (where xxxxx represents the last five digits of the receiver serial number).

Enter password: **12345678**

Step 2: Login the Web

Select the receiver, open a web browser and then enter the following IP address:

<http://192.168.1.8>

Tip: Most web browsers for computers / laptops and smart phones / PDAs support the receiver Web GUI

Step 3: Enter the default login settings to access the main page

- Username: admin
- Password: admin

After accessing the main page, configuration menus are listed on the left, and receiver's settings on the right. Each configuration menu will be demonstrated in the following sections.

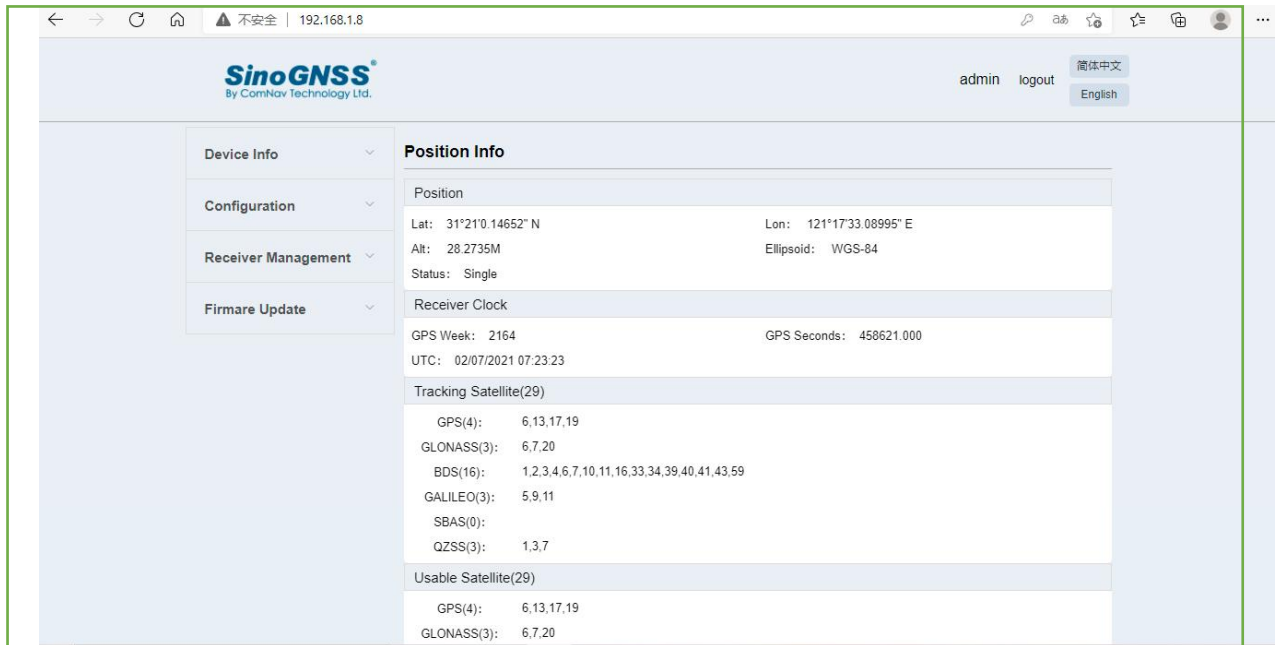

3.3.1 Checking the receiver status

In the section, you can check System information, Status, 4G Network, Bluetooth, Wifi, Position info, satellite info.

(1) System information, includes the basic information includes receiver type, serial number, system firmware version, board firmware version, radio firmware (radio type), front panel firmware (Mars doesn't have front LCD panel), Web version.

(2) Status: Show the device status and data link status, includes work mode, data link, internal storage capacity and current free storage. The default work mode is rover with the new device, others will be same with the Survey Master settings. Data link status will vary from different work mode, the default is null.

System information		Status	
Receiver Type:	Mars	Device Status	
Serial Number:	M11L00072	Work Mode:	Rover
Firmware Version:	V1.4.3	Data Link:	
Board Firmware :	610QR-229T2-1	Capacity:	7.4GB
Radio Firmware:	V1.0.2	Free Storage:	7.4GB
Front Panel Firmware:	null	Data Link Status	
Web Version:	V1.2.0		

(3) 4G Network, when there is SIM card inside in the receiver, it will start itself, and read the signal intensity, APN, and show started. If there is no SIM card inside, it will show stopped.

4G network

Signal Intensity: 31
 Sim Card State: OK
 SIM ID: 898600670920F8002133
 Net Status: Started

APN:
 Username:
 Password:

4G network

Signal Intensity: 31
 Sim Card State: ERR
 SIM ID:
 Net Status: Stopped

APN:
 Username:
 Password:

(4) Bluetooth information, shows Bluetooth name and Mac address, Bluetooth name cannot be changed; WIFI information, shows WIFI name, current Wifi password and Mac address. The Wifi password is 12345678, the client can change the password, click **Save config** to save configuration.

Bluetooth

Name:
 Mac Address: a4:04:50:a6:41:dd
 Status: Started

Wifi

Wifi Name:
 Wifi Password:
 Mac Address: F5:C8:7d:41:01:79
 Status: Started

(5) Position info, shows position status, clock status, tracking satellites, used satellites and DOP status.

Position Info

Position

Lat: 31°21'0.09639" N Lon: 121°17'33.09980" E
 Alt: 30.1361M Ellipsoid: WGS-84
 Status: Single

Receiver Clock

GPS Week: 2170 GPS Seconds: 448592.000
 UTC: 13/09/2021 04:36:14

Tracking Satellite(30)

GPS(3): 6,13,19
 GLONASS(4): 1,8,21,22
 BDS(17): 1,2,3,4,6,7,10,11,16,33,34,39,40,41,43,56,59
 GALILEO(3): 7,8,15
 SBAS(0):
 QZSS(3): 1,3,7

Usable Satellite(27)

GPS(3): 6,13,19
 GLONASS(4): 1,8,21,22
 BDS(17): 1,2,3,4,6,7,10,11,16,33,34,39,40,41,43,56,59
 GALILEO(3): 7,8,15
 SBAS(0):
 QZSS(3): 1,3,7

DOP:

PDOP: 1.7826 HDOP: 1.1588
 VDOP: 1.3547 TDOP: 1.3440

(6) Satellites Info, includes Tracking graph, Tracking skyplot.

Satellite Info

SV	Type	Elev.	Azim.	L1.	L2.	L5.
5	GPS	16	125	47	42	0
12	GPS	16	141	46	41	0
18	GPS	49	222	43	35	49
2	QZSS	41	135	47	0	52
3	QZSS	13	174	42	0	50
7	QZSS	53	199	42	0	52
1	BDS	45	141	46	50	48
2	BDS	0	0	0	40	0
3	BDS	52	201	47	49	47
4	BDS	34	123	47	50	48
6	BDS	56	185	46	50	49
20	BDS	30	94	47	0	50
36	BDS	46	176	52	0	54
38	BDS	58	191	51	0	52
--	--	--	--	--	--	--

Sky View >>>
Tracking-Graph >>>



3.3.2 Configuration

This section includes Satellite tracking, work mode, Antenna setup and Base station configuration.

- **Satellite tracking**, includes Smooth Pseudorange, default is OFF; Elevation mask: default is 10 degrees; and every system status, supports to change by customers, click **Enter** to save settings, click **Cancel** to cancel the settings.
- **Antenna setup**: measure method supports Slant height and vertical height, choose Antenna type, and setup antenna height, click Enter to save configuration.

Antenna Setup

Antenna Setup

Slant height(S):

Measure method: Slant height(S) Vertical height(H)

Antenna Type: Mars(NGS)

Name	Radius(R)	Distance Measurement (L)	Height from bottom(V)
Mars(NGS)	0.0615	0.0243	0.0634

- **Base station configuration:** Setup the station ID, Antenna height, measure method supports slant height and vertical height; then click **Get position** to set the current position or you can enter the coordinate yourself, click **Start** to start the base setup, click **Stop** to stop the base setup.

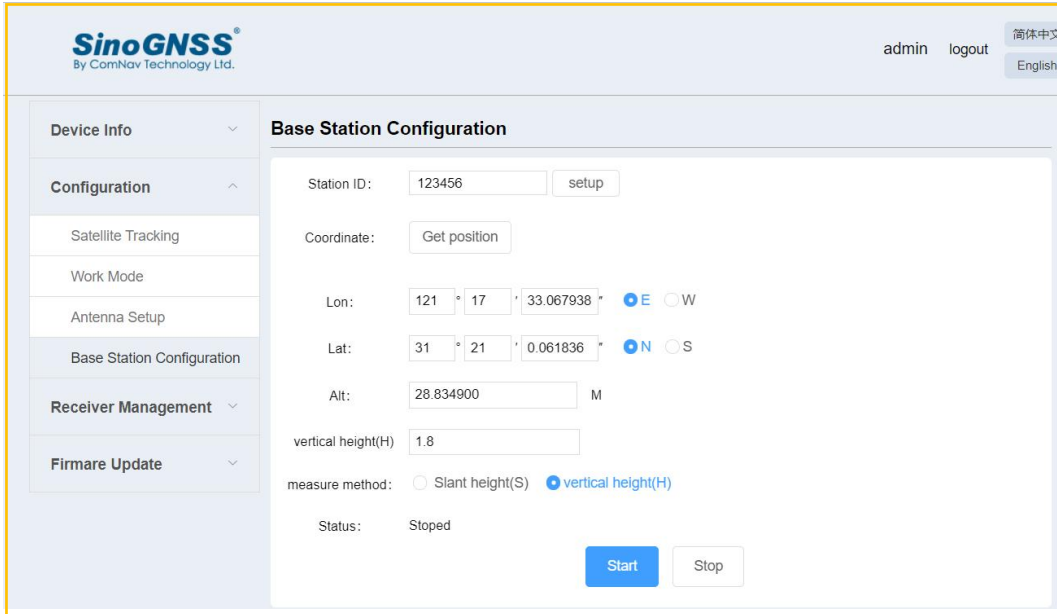

- **Work mode**, includes rover settings and base settings.

Rover settings include Ntrip Client (Same with internal GSM in Survey Master) and Radio (Same with internal radio in Survey Master).

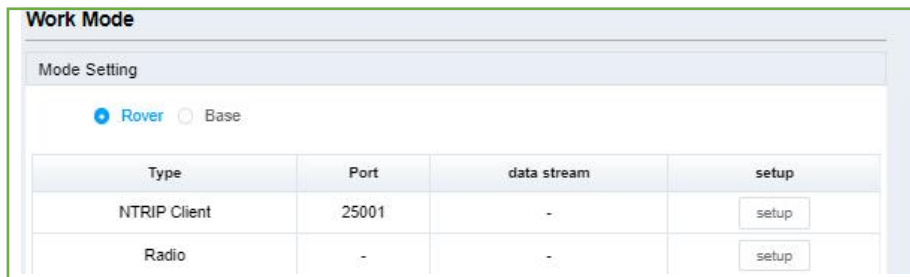

(1) Ntrip Client: Set Ntrip version, includes NTRIP v1.0 and NTRIP v2.0, IP, port, username, password, then click **Get List** and select mountpoint, check on **Use**, click **Enter** to apply the Ntrip Client; Check off **Use**, click **Enter** to cancel the work mode.

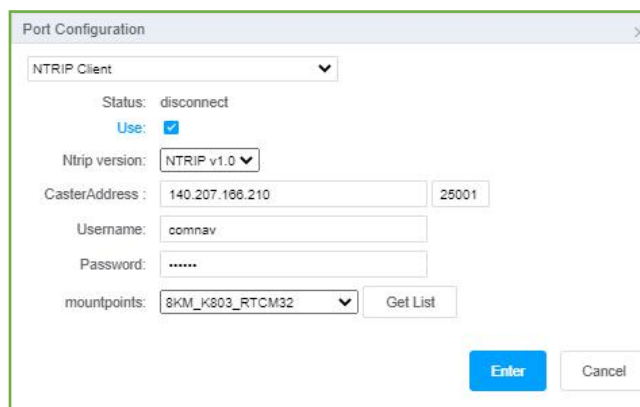

When setup the Ntrip Client, you can go to Device Info->Status to check current device status and datalink status.

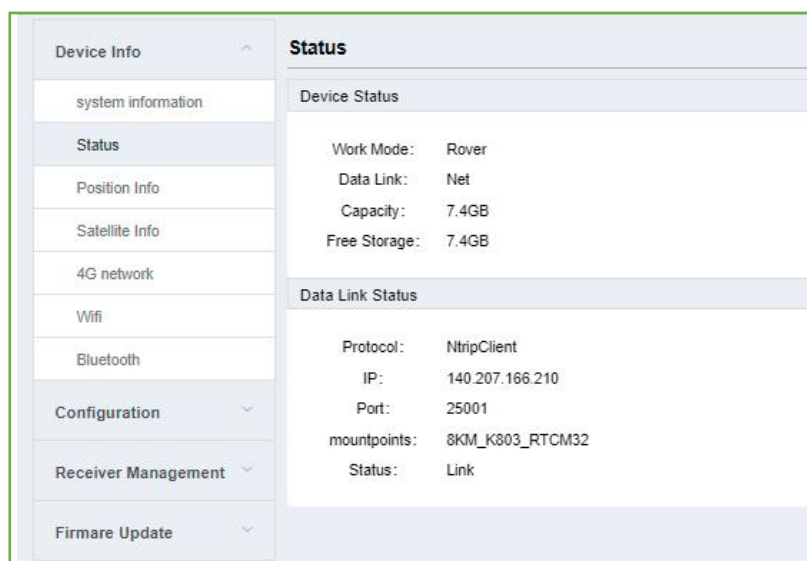

(2) Radio: The model is RX, set the frequency, minimum interval is 12.5 KHz; the protocol is Transparent; set the power, supports 0.5w, 1w and 2w; check on **Use**, click **Enter** to apply the internal radio; Check off **Use**, click **Enter** to cancel the work mode.

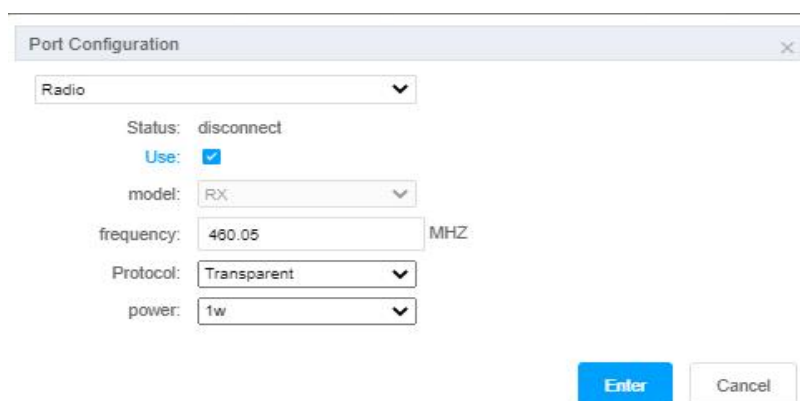

After setup, you can go to Device Info->Status to check device status.

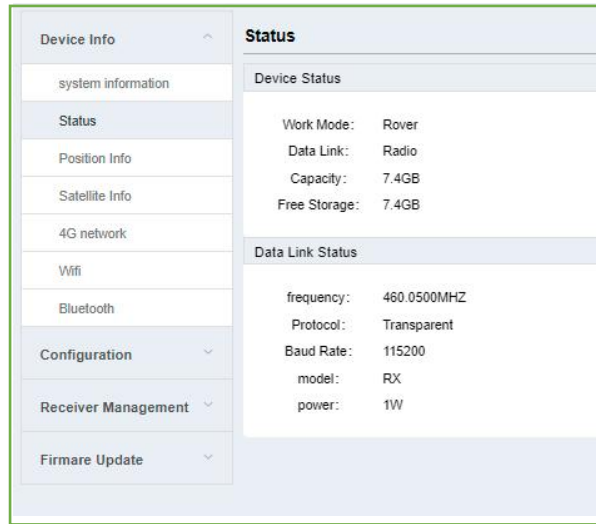

Base settings include Ntrip Server (Same with internal GSM in Survey Master) and Radio (Same with internal radio in Survey Master).

(1) Ntrip Server:

a) Start the base: if you have started the base setup in **Base Station Configuration**, then no need to setup again, just click **Next**; If you have not started base setup, you can go to **Base Station Configuration** to set the base, or you can set the station ID, and set the base coordinate here, then go to **Antenna Setup** to set the base antenna, then start the base, click Next to the Ntrip settings.

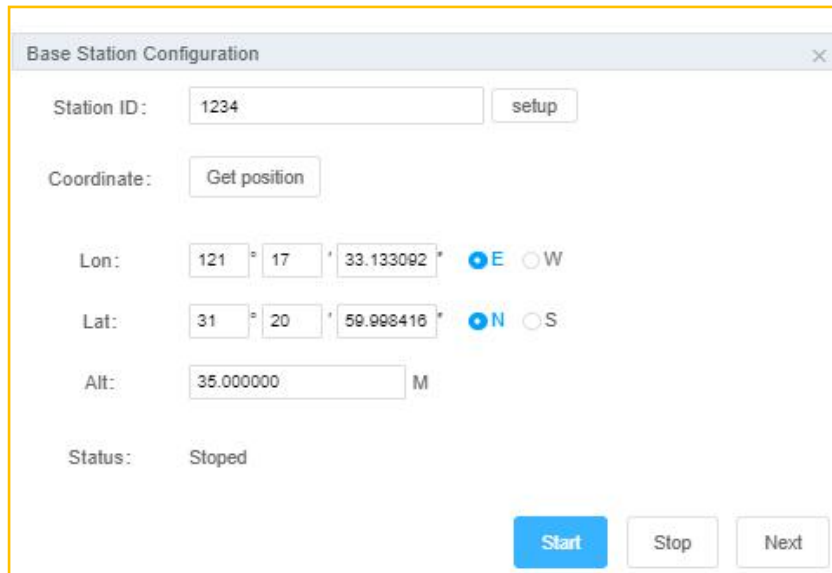

b) Ntrip settings: Choose Ntrip version, set IP, port, username, password, mountpoint, and choose data stream, supports RTCM3.2, RTCM3.2(MSM5), RTCM3.0, RTD, CMR. Check on **Use**, and click **Enter** to apply, click **Cancel** to cancel apply; Check off **Use**, and click **Enter** to cancel the previous base setup.

The screenshot shows a 'Port Configuration' dialog box with the following fields and options:

- NTRIP Server:** A dropdown menu.
- Status:** disconnect
- Use:**
- Ntrip version:** NTRIP v1.0 (dropdown)
- CasterAddress:** 140.207.166.210 (text input) and 25001 (text input)
- Username:** comnavtest (text input)
- Password:** (password input)
- mountpoints:** Base (text input)
- data stream:** RTCM3.2 (dropdown)
- Buttons:** Enter (blue), Cancel (grey)

After you setup base using Ntrip server successfully, you can go to Device->Status to check current base settings, and the rover can get the mountpoint from the server you set.

(2) Radio:

a) You need to setup base station coordinate first, refer to the Ntrip Server settings.

b) Setup the radio parameters: The model is TX, set the frequency, minimum interval is 12.5 KHz; the protocol is Transparent; set the power, supports 0.5w, 1w and 2w; choose data stream, supports RTCM3.2, RTCM3.2(MSM5), RTCM3.0, RTD, CMR; check on **Use**, click **Enter** to apply the internal radio; Check off **Use**, click **Enter** to cancel the work mode.

After setup the base, you can go to the Device Info-> Status to check base settings.

The screenshot shows a 'Port Configuration' dialog box with the following fields and options:

- Radio:** A dropdown menu.
- Status:** Use
- Use:**
- model:** TX (dropdown)
- frequency:** 460.05 (text input) MHZ
- Protocol:** Transparent (dropdown)
- power:** 1w (dropdown)
- data stream:** RTCM3.2 (dropdown)
- Buttons:** Enter (blue), Cancel (grey)

3.3.3 Receiver Management

This section includes Data Transfer, Data record, Data Download and Receiver Utility.

3.3.3.1 Data Transfer

Data transfer has five types: Com1, Com2(Bluetooth), TCP Server, TCP Client, Web Ntrip.

- **Com1:** This is setup to transfer the data through com1 port of the OEM board inside. You can use serial port cable to check the data transmission (the lemo port is connected to Com1 of the OEM board inside).

(1) Baud rate supports 115200, 57600, 38400, 19200, 9600, the default is 115200.

(2) The supported file formats include navigation data, raw observation data, RTCM3.2, RTCM3.2(MSM5), RTCM3.0, RTD, CMR.

(3) Observation and ephemeris output frequency support 1s, 2s, 5s, 10s and 15s.

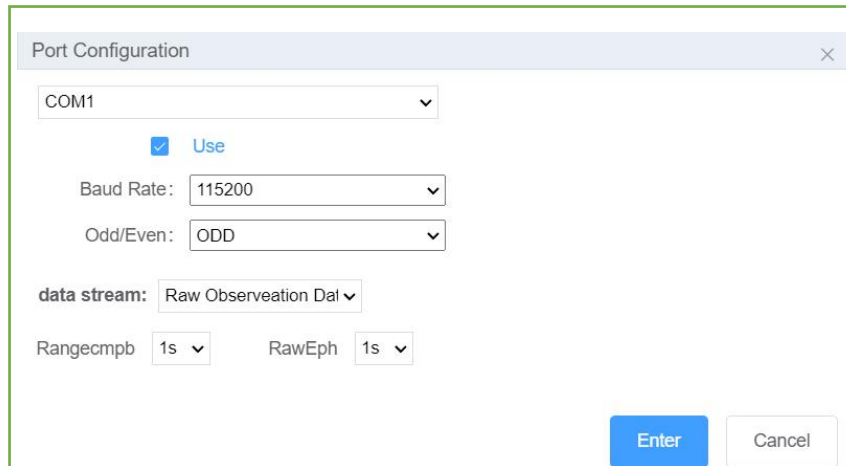

The screenshot shows a 'Port Configuration' dialog box with the following settings:

- Port: COM1
- Use
- Baud Rate: 115200
- Odd/Even: ODD
- data stream: Raw Observation Data
- RangeCmpb: 1s
- RawEph: 1s

Buttons: Enter, Cancel

- **Com2:** This is used to output data through com2 port of the OEM board (connected to the Bluetooth modem), you can output NMEA data via this port, it is the important step to connect the receiver to other brand software.

(1) Baud rate supports 115200, 57600, 38400, 19200, 9600, the default is 115200.

(2) The supported file formats include navigation data, raw observation data, RTCM3.2, RTCM3.2(MSM5), RTCM3.0, RTD, CMR.

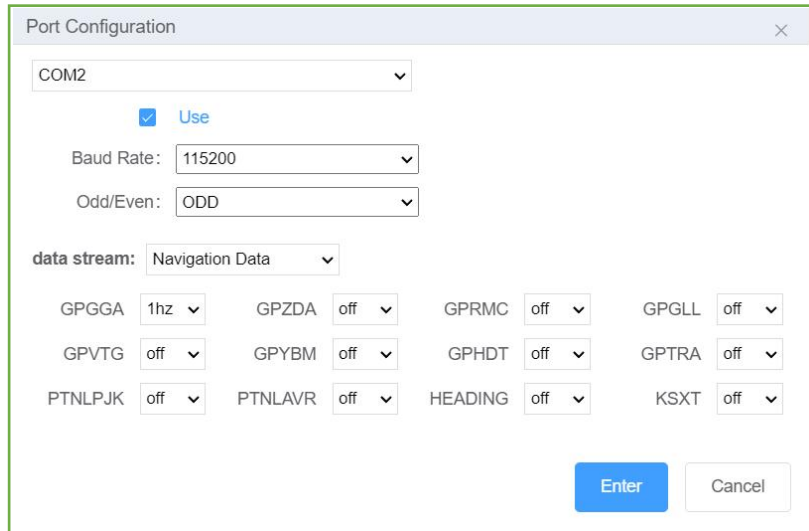

(3) NMEA data output frequency supports 1hz, 2hz, 5hz, 10hz, 15hz.

- **TCP Server:** You can output data through TCP server, then use TCP client to get data. For example, connect your rover or computer and Mars receiver in the same LAN, setup Mars to output RTCM data via TCP server, and rover receives via TCP Client.

The supported file formats include navigation data, raw observation data, RTCM3.2, RTCM3.2(MSM5), RTCM3.0, RTD, CMR.

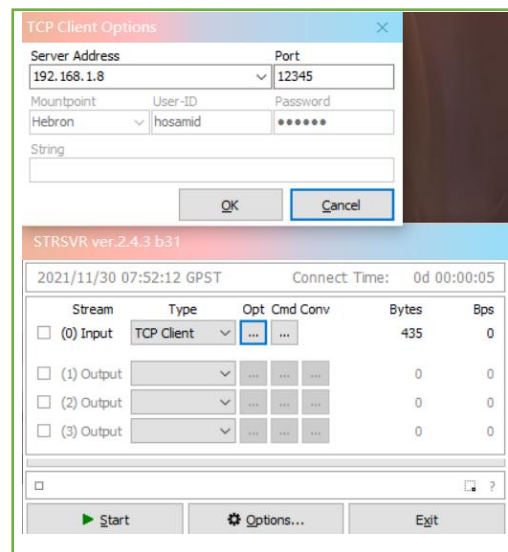
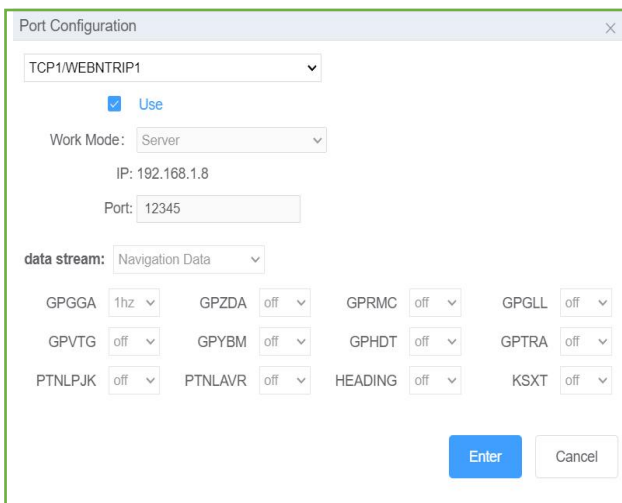

- **TCP Client:** If you have a TCP server with a static IP, you can output the data via TCP Client, then the data will be transmitted to your TCP server. The IP is your PC IP, the port should be mapped. For example, you can output the NMEA data to your TCP Server, then you can check the status of the rover in the office while the rover works in the field.

- **WEBNTRIP:** This function can be used to work with Drone via WIFI.

(1) Base setup: setup base coordinate and antenna first.

(2) WEB configuration: setup the IP 192.168.1.8, port 12345, mountpoint T31U02027, and choose RTCM3.2(MSM5), then check on Use, click Enter, it will transfer data through WIFI

(3) Connect your drone remote with the receiver WIFI.

(4) Configure the drone, select Ntrip Client, setup IP 192.168.1.8 and port 12345, get the mountpoint T31U02027, then the drone can do RTK.

3.3.3.2 Data record

This is used to log static data, the data will be saved in the receive, you can download data via web interface, go to chapter 3.3.3.3 for more information, or you can use USB

cable to connect PC and download static data.

In recording setting interface, you can get following information:

- Current internal memory capacity and free storage; you can click Format Disk to format the receiver internal memory;
- Current record state, data format, record mode.

Data record					
record Setting					
Position	Capacity	Free Storage	Format Disk		
Internal memory	7360M	7164M	<input type="button" value="Format Disk"/>		
number	Name	Record State	data format	record mode	Operation
1	record1	Unrecorded	CNB	Manual Recording	<input type="button" value="setup"/>

Click **Setup** to configure the static settings:

- **Name:** You can choose record1, then the file will be saved in record1 folder.
- **Sample Interval:** change the sample interval of observations, the maximum data rate is 20 Hz, the minimum is one observation per minute, it supports 0.05/0.1/0.2/0.5/1/2/5/15/30/60 S
- **File Split:** supports every 15 minutes or 1\2\4\24 hours to save a file, or you can choose Manual mode, then it will save a one file when you manually stop the record by pressing on the static button, or click the Stop button. If you select 24 as file split, it will create two data files when it occurs to 24 o'clock (UTC Time). One is from start time to 24 o'clock, another is from 0 o'clock to end time.
- **Data format:** Supports CNB, RINEX 2.10, RINEX 3.02
- **Loop:** When storage is full, Yes means delete earliest data and store continually, No means stop recording
- **Storage Space:** Separate storage space in internal memory
- **Record mode:** logging data manual recording or auto recording.

- **Auto recording:** when you set automatically, it will record static data automatically when the receiver tracks satellites, and you can stop recording by pressing the static button on the receiver;
- **Manual recording:** when you set manually, then it will not record data automatically when the receiver tracks satellites, need to press the static button on the receiver. Click Enter to start the recording, and it will save the configuration, you can stop the recording by pressing the static button or click Stop on the interface.

The screenshot shows the 'Disk Record Setting' dialog box with the following configuration:

- Record State: Unrecorded
- Name: record1
- Sample Interval: 1s
- File Split: 1h
- data format: RINEX3.02 (selected)
- Loop: No (selected)
- Storage Space: 5000
- record mode: Manual Recording
- Buttons: Cancel, Start

The screenshot shows the 'Disk Record Setting' dialog box with the following configuration:

- Record State: Recorded
- Name: record1
- Sample Interval: 1s
- File Split: Manual mode
- data format: CNB (selected)
- Loop: No (selected)
- Storage Space: 5000
- record mode: Manual Recording
- Buttons: Cancel, Stop

3.3.3.3 Data Download

- Firstly, select record Name, File type (CNB\Rinex3.02\Rinex2.10) and the date.
- Then click **Get Data**, you will see data files.
- Click **Download** icon to download the data file you need; or click **Delete** icon to delete this file; click **Select All**, you can select all the data in the current interface, download and delete them in batches. Rinex files include observations and ephemeris and not are zip files.

Data Download

record Setting

Name: 1-CNB

File Type: CNB **RINEX2.10** RINEX3.02

Select Date: 2021-08-11

Get Data

Item	FileName	Size	download	
<input type="checkbox"/>	1 N31L025942231105.21C	9.07KB	download	delete
<input type="checkbox"/>	2 N31L025942231105.21G	2.82KB	download	delete
<input type="checkbox"/>	3 N31L025942231105.21L	15.32KB	download	delete
<input type="checkbox"/>	4 N31L025942231105.21M	0.00B	download	delete
<input type="checkbox"/>	5 N31L025942231105.21N	5.32KB	download	delete
<input type="checkbox"/>	6 N31L025942231105.21O	50.41KB	download	delete

select All delete First End Last Next Go to 1 Total 1 10/page

3.3.3.4 Receiver Utility

In this section, you can control Mars remotely, including:

- Reboot: Restart the receiver
- Factory Default: recover the receiver to factory default setting

Receiver Utility

Reboot

Factory Default

3.3.3.5 Firmware update

You can update the system firmware (OS), board firmware (GNSS), front panel firmware (LCD) and radio firmware (RADIO) in this menu. Select system, GNSS, RADIO firmware upgrade according to your demand, then click Browse to select the latest firmware version. Click Install, a progress bar shows 0 to 100% and status will be “Not allowed to do other operations during the upgrade”. When completing firmware update, the receiver will restart automatically and information prompted below

Tips:

Mars receivers don't have front LCD panel, so LCD firmware will not be updated.

*The supported firmware file is only *.bin format.*

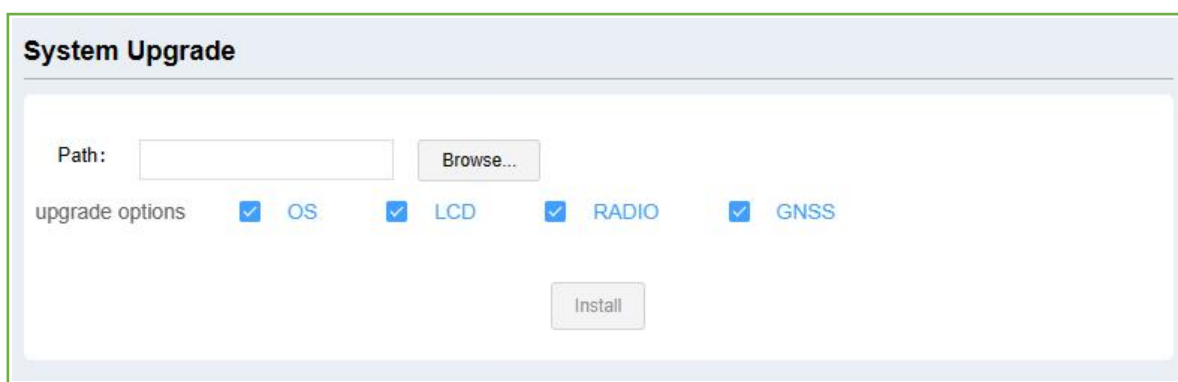

4. Static survey

This chapter describes static survey through Mars receiver and CRU software. For static survey, you cannot change settings through front panel, you can configure it via Compass Receiver Utility (CRU): 1) Receiver configuration; 2) check receiver settings and status; 3) convert data to Rinex format.

4.1 Receiver Configuration

1. Download and install CRU software from the link below (ensure the driver is properly installed in your PC):

<http://www.comnavtech.com/download.asp?bigclassid=28>

2. Put a battery in the Mars receiver and turn it on.

3. Connect the receiver with your PC through serial port cable.

4. Click set port in CRU -> select proper serial port in the serial port option-> enter proper baud rate -> click Ok to complete receiver connection. The SN of receiver will appear in the title bar if connected successfully.

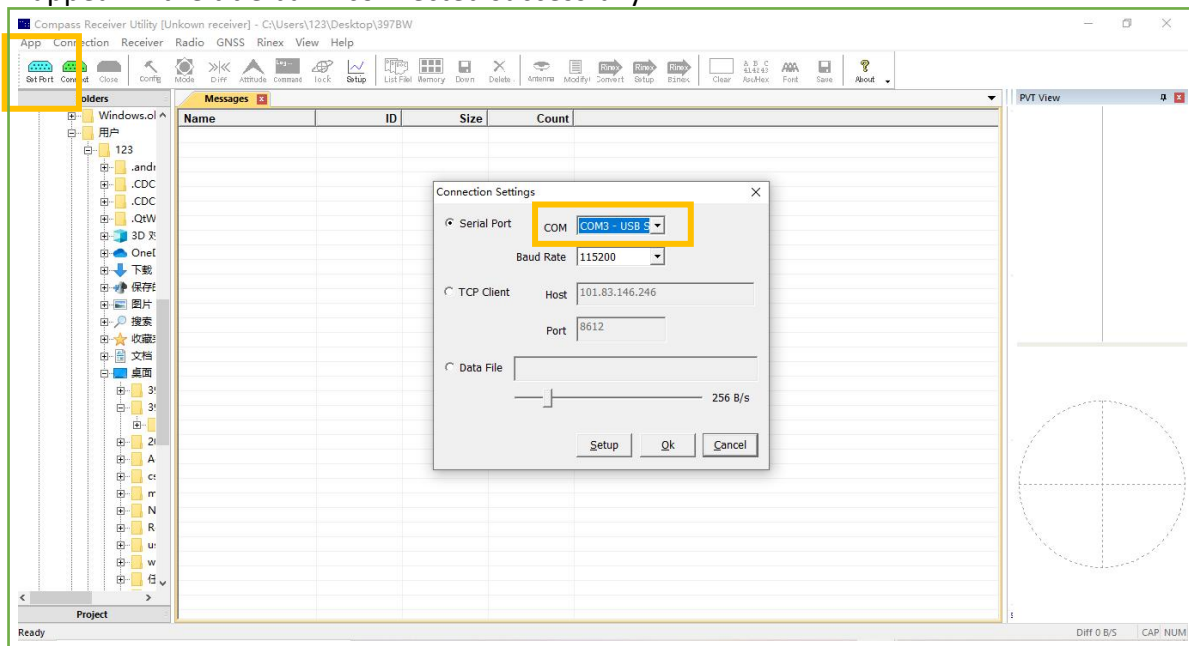

Tips:

1) For Mars receivers, USB cable is only used to download raw observation data, cannot to connect to CRU software and update firmware;

2) With 7-pin Lemo to RS232 cable, you can connect Mars receiver with external power or firmware upgrade.

3) It can not to configure the static settings, only supports to configure using web UI.

4.2 Static Data Collection

Static survey is mainly used for the control survey. To reach millimeter accuracy, follow as below:

- At least 3 GNSS receivers are required to form a stable triangulation network.
- It is better to set Data Log Session as manual on the known point.
- Power off the receiver before moving to other observation site.
- To quickly post-process static observation raw data, write down the station name, receiver SN, antenna height, start and end time for each observation site.

Tip: You can start recording static data in the front panel, it's convenient for you.

4.3 Static Data Download

The raw observation data is saved in internal memory of Mars receiver, when connected with PC via USB cable, the Mars receiver can work as a USB Flash Disk, which means you can copy or cut static data to PC directly.

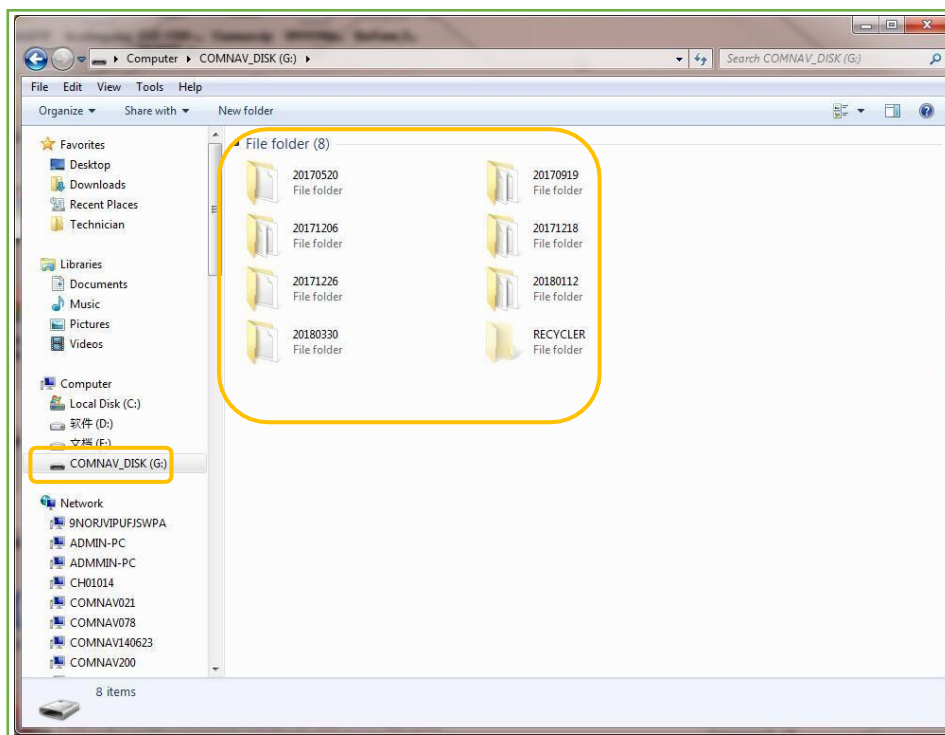

Tips:

1. You need to put a battery inside first, and turn it on, then you can connect to the PC.
2. Default memory for Mars receiver is 8GB, and 16GB, 32GB optional.
3. The receiver will stop recording raw data if the internal memory runs out.

4.4 RINEX Convert

After copy raw observation data to PC, you can convert the data from ComNav binary format

(* .cnb) to RINEX in CRU software.

1. Start CRU software;
2. Click **Folders** and select the path of your CNB data;
3. Click Rinex Convert to check all raw data on main window. Right click on the file to modify antenna, Convert Settings and Convert to RENIX, or use fast icon in standard bar.

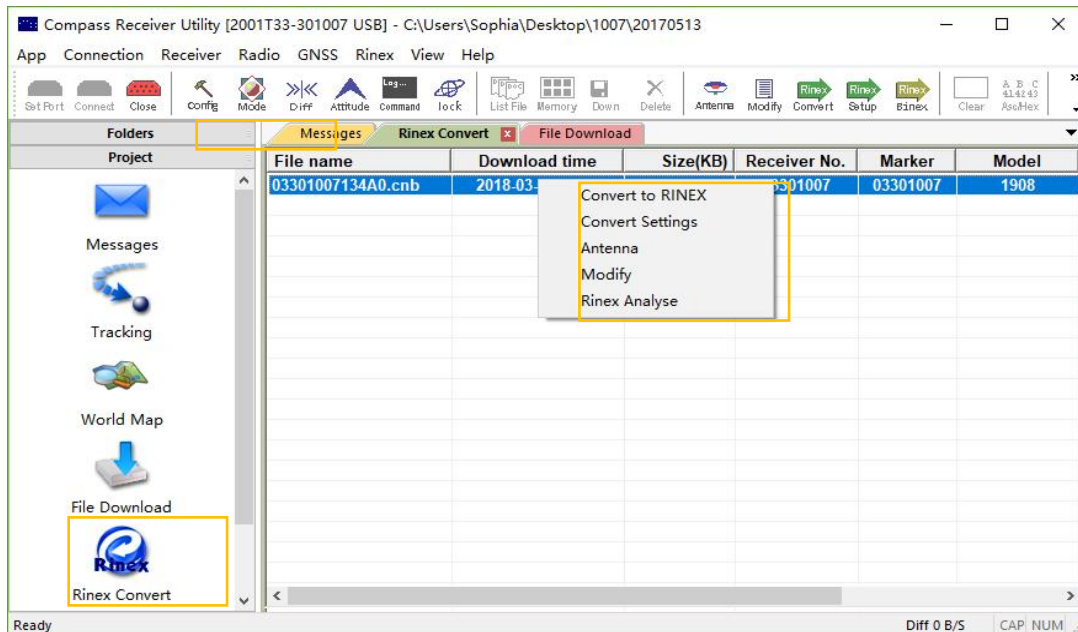



4. Click  to select the **Antenna Type** and **Measurement**. If you cannot find Mars antenna.

1) Input the value of R0 (horizontal offset from measurement mark to phase center), h0 (vertical offset from measurement mark to phase center) and h1 (vertical offset from measurement mark to receiver bottom). R0 is 0.0615m, h0 is 0.0243m and h1 is 0.0391m respectively for Mars receiver;

2) Or check **Enable antenna configure file** to select **Antennas.ini** file to select Antenna

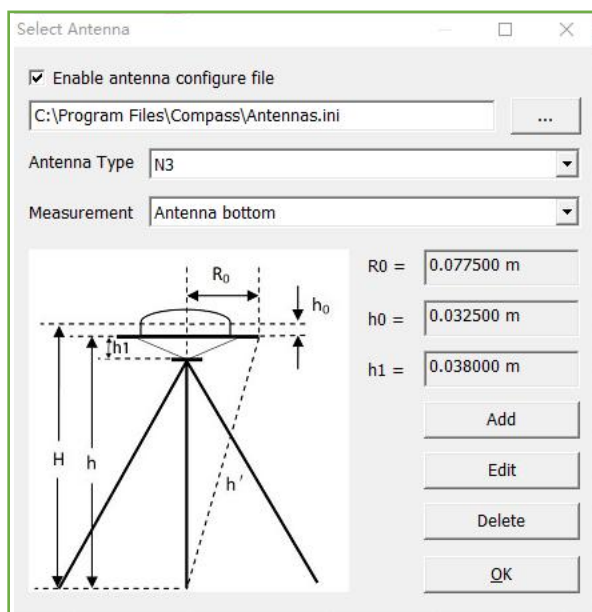
type again. You can also add, edit and delete antenna types based on your requirement.



- Click  to change **Convert Settings**, mainly export format and export observation information.

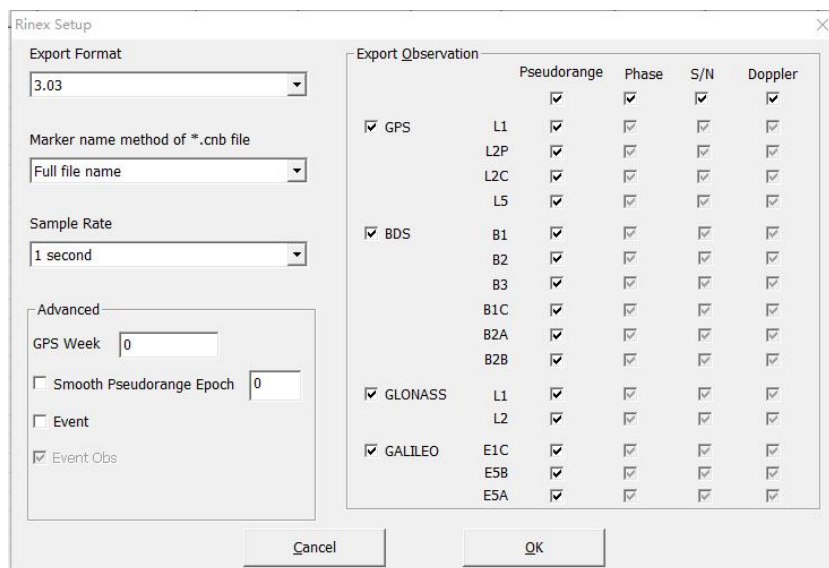

Tip: In some Post Processing software, the BeiDou observations cannot be processed, you can uncheck the BeiDou B1,B2,B3 observations.

- Click  to Convert to RINEX, the RINEX data will be save in the same path as raw observation data.

5. Real-Time Kinematic Survey (RTK)

This chapter introduces how to conduct RTK Survey with Survey Master Software, including software installation, start a new project, receiver connection and RTK working modes (CORS).

5.1 Installation of Survey Master

Survey Master is available on Google play, you can download for free and install the software to SinoGNSS controller R60.

Also you can download the latest version from our website:

<https://www.comnavtech.com/>

5.2 Wizard function in Survey Master

Follow the Wizard, you can quickly learn the general workflow of Survey Master, also you can quick start your survey by this function no matter you are experienced one or new user.

In Project menu, tap Wizard.

1. **Project**: Click **Select** to go into Project interface to create or select a project. For

detailed information, you can refer to [chapter 5.3](#).

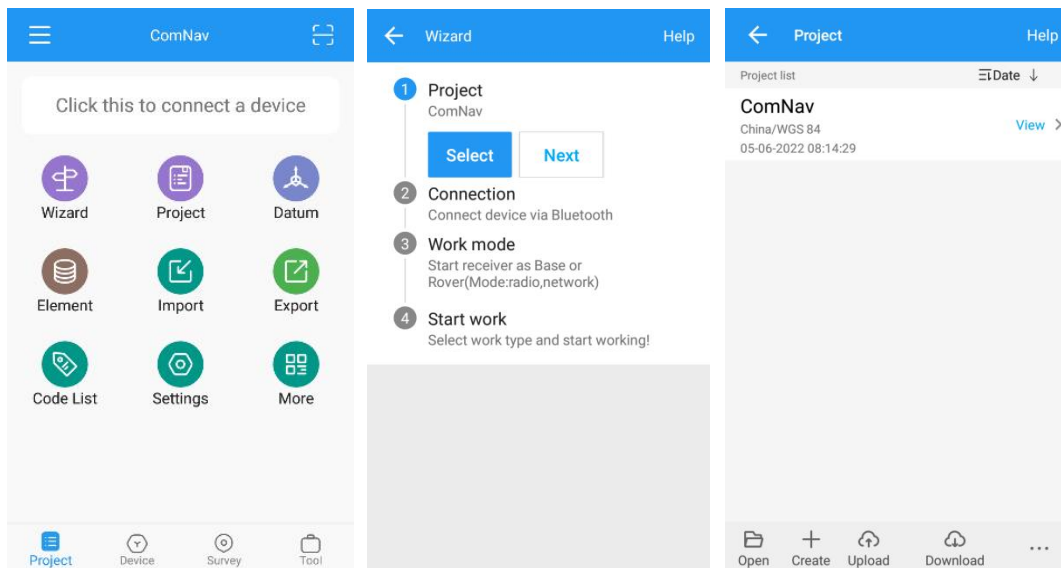

2. **Connection**: Click **Select** to go into Bluetooth connection interface. For detailed information, you can refer to [chapter 5.4](#).

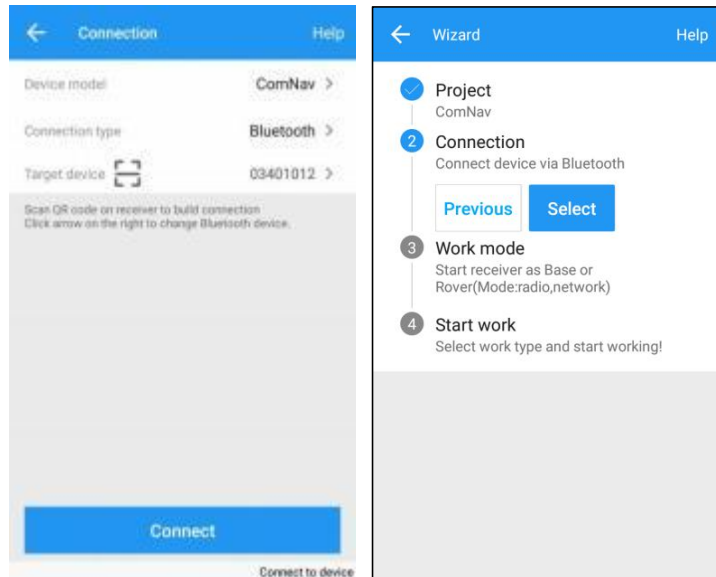

3. **Work mode**: Click **Select** to go into Quick Setup interface to start your receiver as Rover. For detailed information, you can refer from [chapter 5.5](#).

You start your receiver as Rover, then you can start work directly of topo survey or stakeout

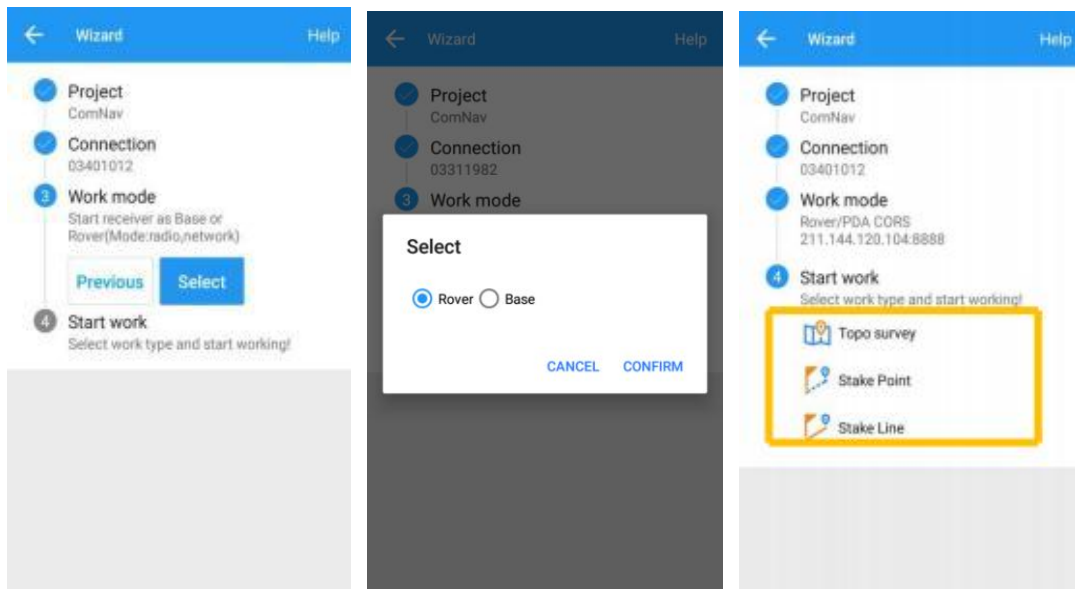

5.3 Start a New Project

Click **Project**, you can use the same Datum with last project, choose a datum in store and scan QR code from other controller to add Datum, even sharing project with cloud.

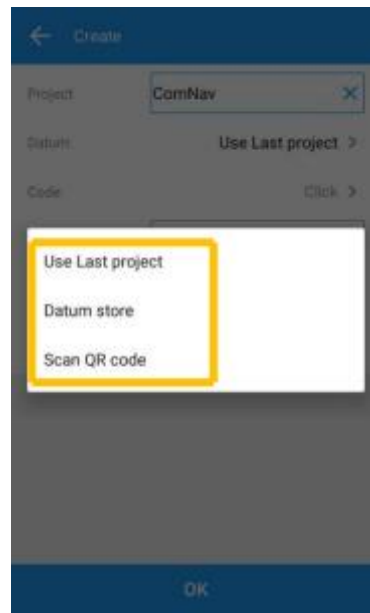
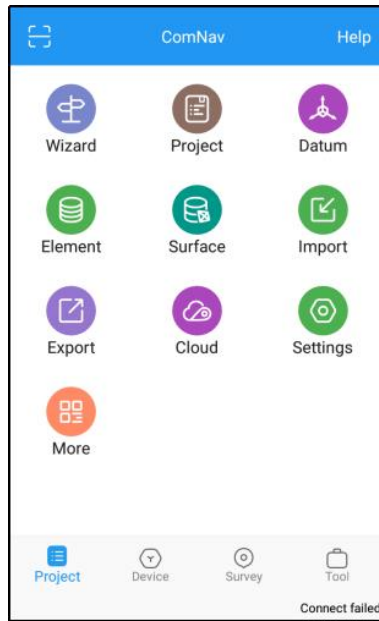

- Select a Predefined datum: You can select datum directly from the list. Survey Master currently has 49 countries datum and will add more afterwards.

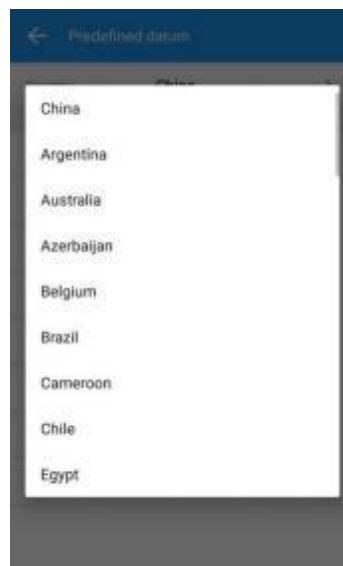

- Create a User defined datum: If you cannot find datum you want in the list, follow instructions below to add one: select Ellipsoid, Projection for your datum, and even seven parameters, geoid model based on your request.

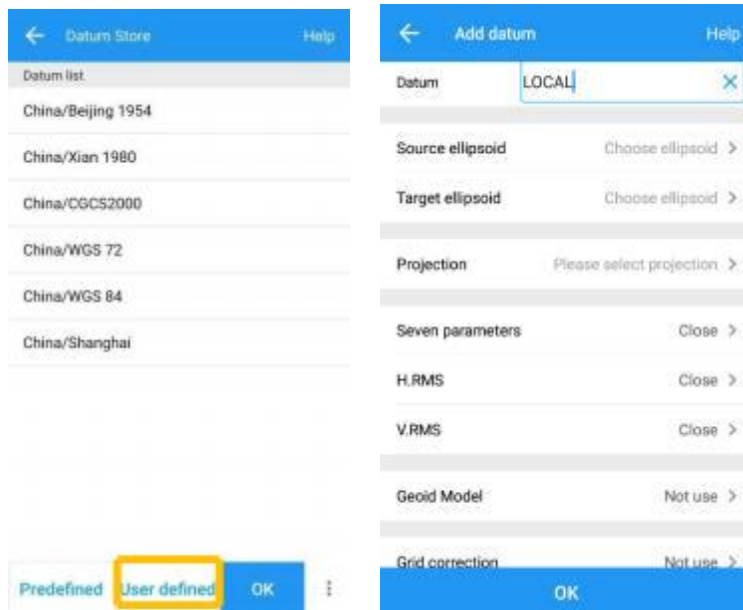

- Share Datum via QR code.
- After you build a project, press the project name, it will generate a QR code. Users can use the Scan function in the main interface to access the coordinate system.

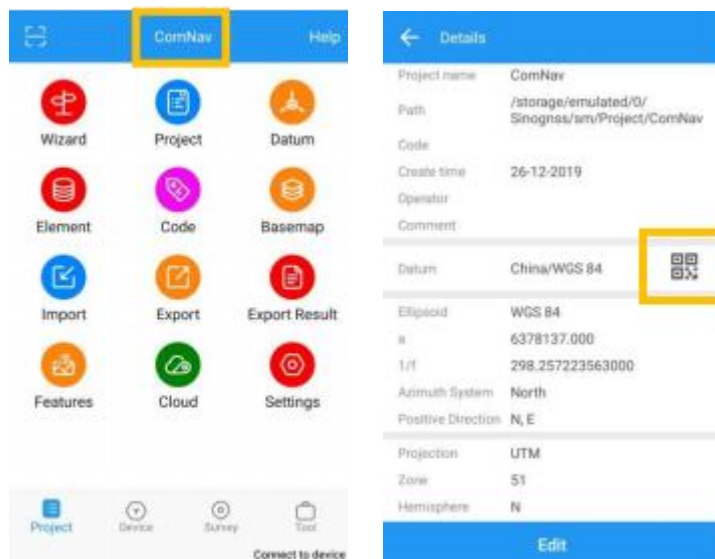

5.4 Bluetooth connection

To connect Survey Master with Mars, switch to **Device** interface, tap **Connection** to go into Bluetooth connection interface.

- Make sure device Bluetooth turned on;
- Click Find device—select SN of your Mars —allow pair.

After connect ComNav receiver, you can check the device version in Device Info.

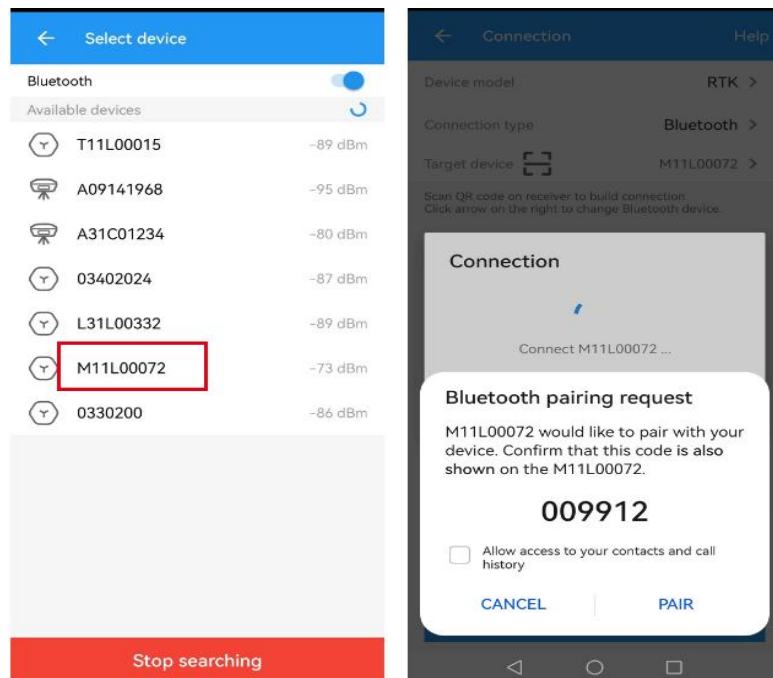
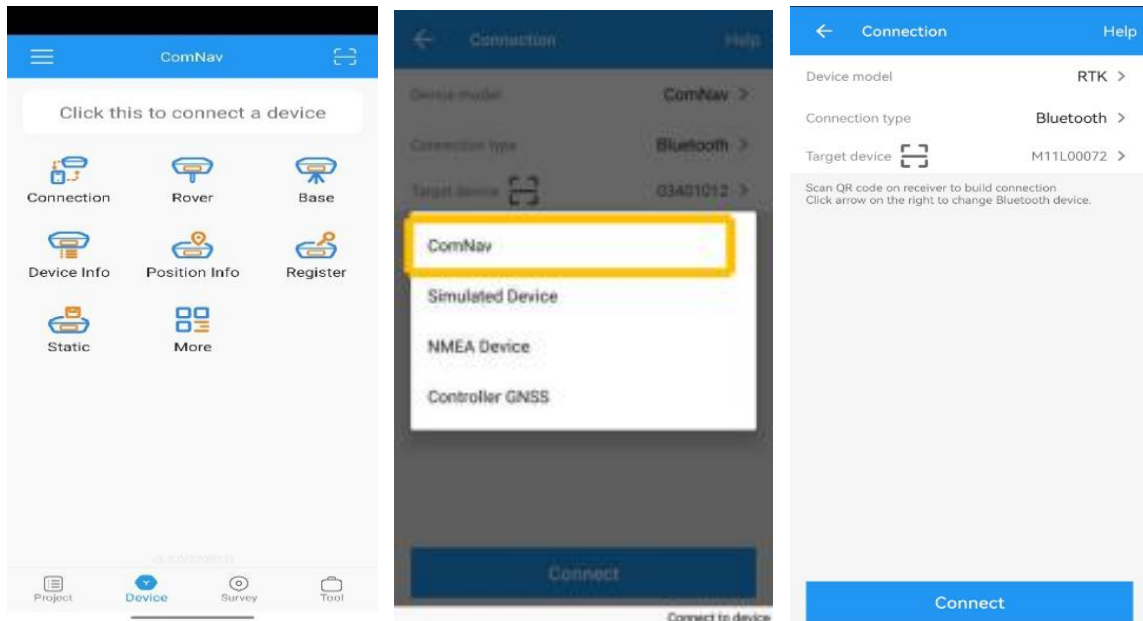

After connected successfully, the top will show the positioning status.

Tip: If you are failed to connect with receiver through Survey Master, you can just follow prompt info to go into the device Bluetooth setting interface to make sure Bluetooth paired successfully. Sometimes you need restart the receiver or Survey Master Software.

5.5 Internal Radio Mode

Mars GNSS receiver supports transmit & receive the correction data in internal radio mode. To conduct the RTK survey in internal radio mode, it requires:

① A controller with software installed

② An extension bar

③ one base receiver and one Mars GNSS receiver

④ Two whip antennas

⑤ A range pole with bracket

⑥ Tripod and tribrach

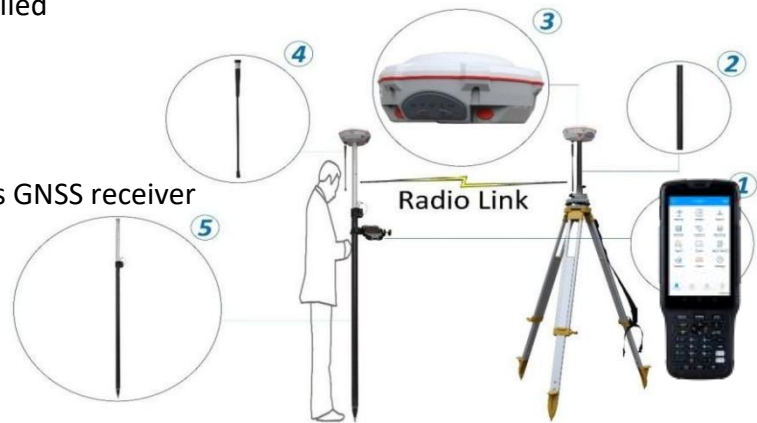

Tip: The external power supply is recommended when Mars set as a base station.

More: Aim to improve the radius of work field, we can change the base receiver's Whip Antenna to External Antenna. And others no need change.



5.5.1 Start Base Station by Survey Master

Firstly, build Bluetooth connection between the Mars receiver and your controller as shown in Chapter 5.4.

Secondly, modify parameters including correction format, antenna type and communication protocols:

- Click Device-> Base ->Add, select Internal radio.

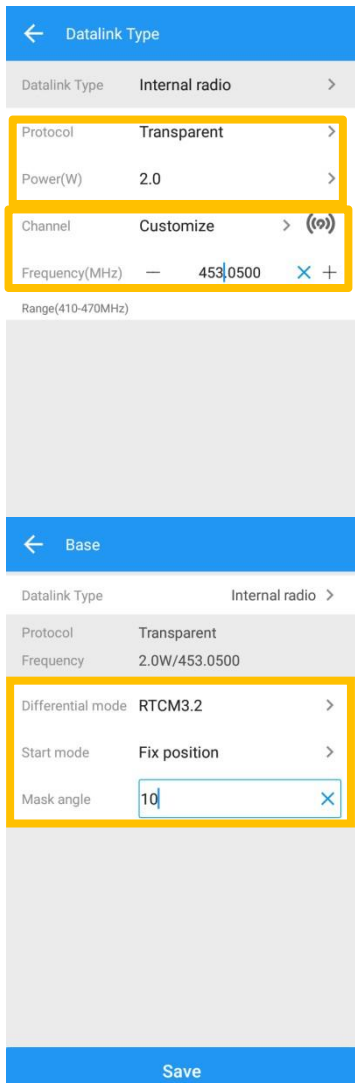
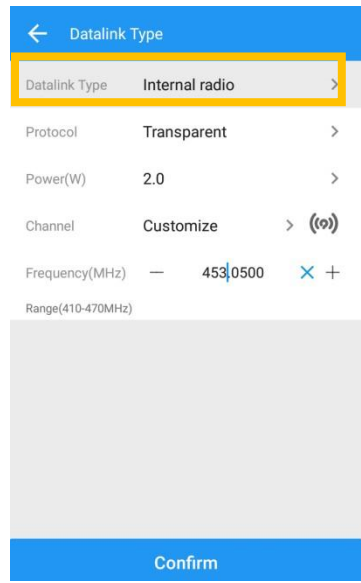
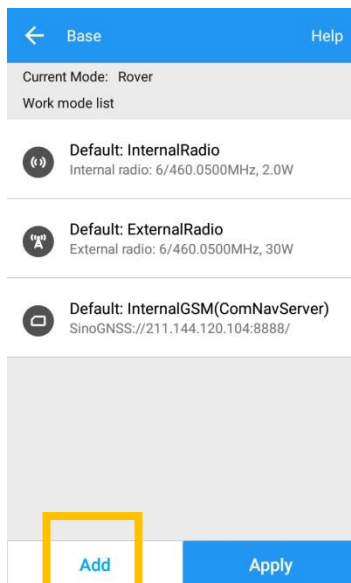
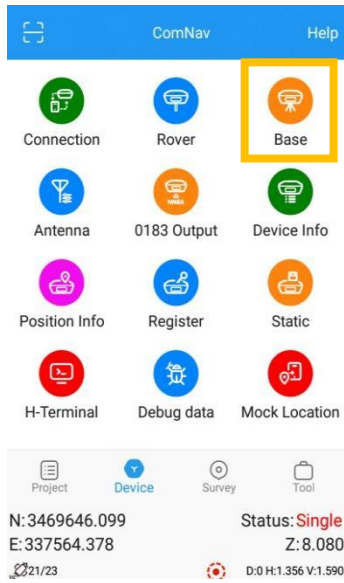

● Protocol and channel: Set protocol and frequency for the

● Start mode: Fix position means you have a known coordinate for base, or get a point from GNSS;

● Differential mode: Support RTCM32, RTCM32(MSM5), RTD, CMR, CMR+(GPS only)

- Library choose: Choose a known point from Element;
- Receive: Receive a point from GNSS;

When start Base succeed, it will show as below in Survey Master.

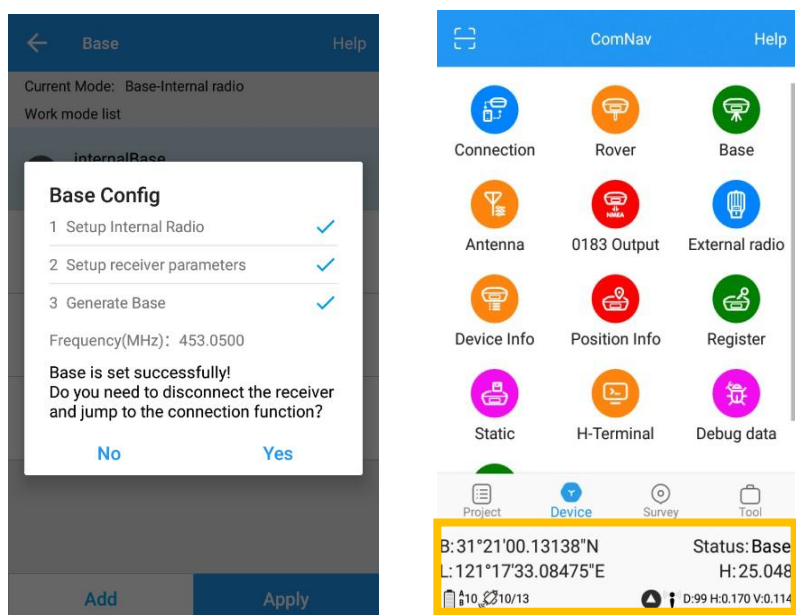

5.5.2 Start Rover Station by Survey Master

- Connect Survey Master with Mars receiver via Bluetooth based on [Chapter 5.4](#).
- Set same protocol and frequency with Base receiver.
- The current status on the bottom will change from Single to Fixed.

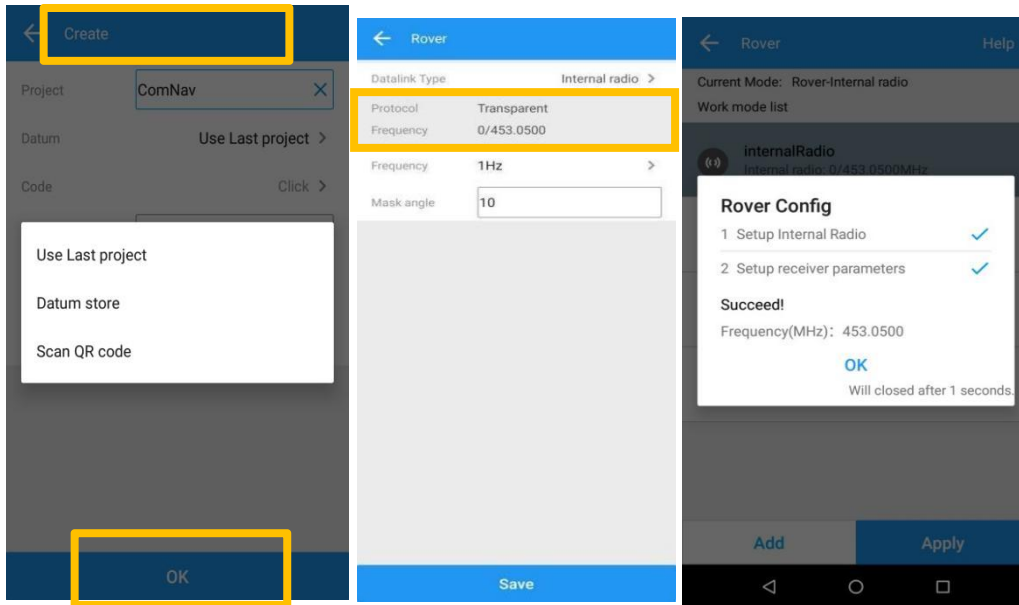

5.6 External radio mode

The external radio mode can extend RTK working distance, which is ideal for areas with high constructions or strong signal interference. To set up external radio mode, it requires:

- Base station
- ① An external radio
- ② An external power supply
- ③ A long whip antenna
- ④ Transmission cables
- ⑤ A base receiver
- ⑥ Tripod and tribrach



Tip: 1) See Appendix A for detailed definition of 7-pin Lemo cable that connects the Mars receiver and external radio; 2) See Appendix B for the operating information of CDL7.

Warning: 1) You MUST connect CDL7 to external antenna firstly and then supply power, otherwise the CDL7 will have a risk of burnout; 2) You'd better put it in a shelter when raining, because it's not water-proof.

- Rover station

① A Mars receiver

② A Whip antenna

③ A controller with software installed

④ A range pole with bracket



- Click **Device-> Base ->Add**, select External radio.

When start succeed, set up the frequency channel, and Rover frequency should be same.

Be sure to set the same baud rate as your CDL7(default value is 38400, you also can change in Parameters tab based on your CDL7).

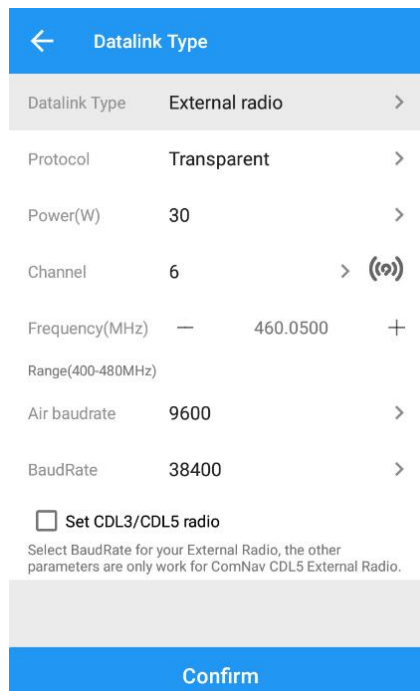

5.7 PDA CORS Mode

Without setting up your own base stations, the Mars GNSS receiver can receive correction data transmitted from continuously operating reference station via PDA's GPRS or WIFI. To do RTK survey in PDA CORS mode, it requires:

- ① A Mars receiver
- ② A controller with SIM card and software
- ③ A range pole with bracket



Configure the Rover as below:

- Make sure your controller can access to internet via SIM card or Wi-Fi, then run Survey Master Software.
- Build Bluetooth connection as shown in chapter 5.4, Click Device -> Rover -> PDA CORS.
- Enter CORS DNS/IP address and port-> Click Source List and select the proper source -> enter User and password.

After Confirm succeed, the diff LED (yellow) on receiver will flash, and software can get a fixed result. It also provides TCP protocol.

The screenshot shows the 'Datalink Type' configuration screen. At the top, there is a blue header with a back arrow and the text 'Datalink Type'. Below the header, there are two rows of settings: 'Datalink Type' set to 'PDA CORS' and 'Protocol' set to 'CORS', both with right-pointing arrows. Below these are several input fields and controls: 'APN' with a gear icon, 'Server' with a dropdown menu showing 'SINOGNSS' and a list icon, 'DNS/IP address' with the value '211.144.120.104', 'Port' with the value '8888', 'Source List' with a dropdown menu and a download icon, 'User' and 'Password' with empty text boxes. At the bottom, there are three rows of radio buttons for '1021-1022', '1023-1024', and '1025-1027', all of which are currently turned off. Below these is a 'VRS' section with a blue radio button that is turned on. At the very bottom, there is a blue 'Confirm' button.

5.8 Internal GPRS Mode

For Internal GPRS mode, Mars receiver supports Point to Point/Points and Ntrip client mode. To acquire the APN (access point number) from the mobile service provider, you need to insert a SIM card into the Mars receiver. It commonly acquires the APN from the mobile network provider, otherwise try to get via the link:

http://www.hw-group.com/products/HWg-Ares/HWg-Ares_GSM_APN_en.html#top

5.8.1 Point to Point/Points mode (P to PS mode)

In point to point mode, the correction data is transmitted from the base station to the server, then rovers can log on the server to get the correction data. Therefore, SIM cards are required both in the Base and Rover.

Tip: ComNav technology provides a free static server address 211.144.120.104:8888, anyone can upload CORS data as long as abide by the agreement.

Below shows Base configuration with ComNav server:

- Server: select SINOGNSS server(IP: 211.144.120.104 and Port:8888)
- BaseName: Click BaseName to get SN of Base receiver directly, when start Rover, just select the name as source
- Differential mode: make sure to choose RTCM3.2
- Fix Position: Click Library choose to select a known point for the Base, or Get from GNSS if you do not have a known point.

The image displays three screenshots of the Mars receiver configuration interface, illustrating the steps for setting up the Base configuration with the ComNav server.

Screenshot 1: Datalink Type

- Datalink Type: Internal GSM
- Protocol: CORS
- APN: CMNET
- Server: SINOGNSS
- DNS/IP address: 211.144.120.104
- Port: 8888
- BaseName: [Dropdown menu]
- User: [Text field]
- Password: [Text field]
- Confirm button

Screenshot 2: Base

- Datalink Type: Internal GSM
- Protocol: SinoGNSS
- Port: 211.144.120.104:8888
- Differential mode: RTCM3.2
- Start mode: Fix position
- Mask angle: 10
- Save button

Screenshot 3: FixPosition

- Base station coord...: Library choose, Receive
- Name: Base:p0
- Code: [Text field]
- Display type: Local grid coordinate
- N: 3469655.236
- E: 337581.203
- Z: 25.088
- Slant(S): 1.850
- Bottom of receiver(H) / Slant(S) (Selected)
- Antenna type: T30(NGS)
- OK button

After successfully starting the Base station, the differential LED (yellow) flashes once per second, which means the Base is broadcasting correction data;

Configure the Rover as below:

- Protocol: Select **SINOGNSS** directly;
- BaseName: Enter the SN of the Base receiver.

The screenshot shows the 'Datalink Type' configuration screen. The 'Datalink Type' is set to 'Internal GSM' and the 'Protocol' is 'SinoGNSS'. The 'APN' field is 'CMNET'. The 'Server' dropdown is set to 'SINOGNSS'. The 'DNS/IP address' is '211.144.120.104' and the 'Port' is '8888'. The 'BaseName' dropdown is empty. A 'Confirm' button is at the bottom.

5.8.2 Internal 4G Ntrip client mode

For Ntrip client mode, Rover acquires correction data from Ntrip(CORS) server.

- Enter proper APN, DNS/IP Address and Port.
- Click Source List, select the proper source-> enter User and Password

The screenshot shows the 'Datalink Type' configuration screen for Ntrip client mode. The 'Datalink Type' is set to 'Internal GSM' and the 'Protocol' is 'CORS'. The 'APN' is 'CMNET'. The 'Server' is 'SINOGNSS'. The 'DNS/IP address' is '211.144.120.104' and the 'Port' is '8888'. The 'Source List' dropdown is empty. The 'User' field is 'sxbhd' and the 'Password' field is masked with dots. A 'VRS' toggle is turned on. A 'Confirm' button is at the bottom.

6. Basic Survey Functions

This section describes the basic survey functions of Survey Master, including point measurement, Topo survey, Auto survey, Area survey, Static, PPK, staking, site calibration, import and export measured points.

6.1 Topo survey

Click Topo Survey-> enter point name, ->click  to start or stop collecting data.

- You can quickly change antenna height in the survey interface.
- Tap Elem to check point coordinates.
- Tap Layer to show the layers you want display on map

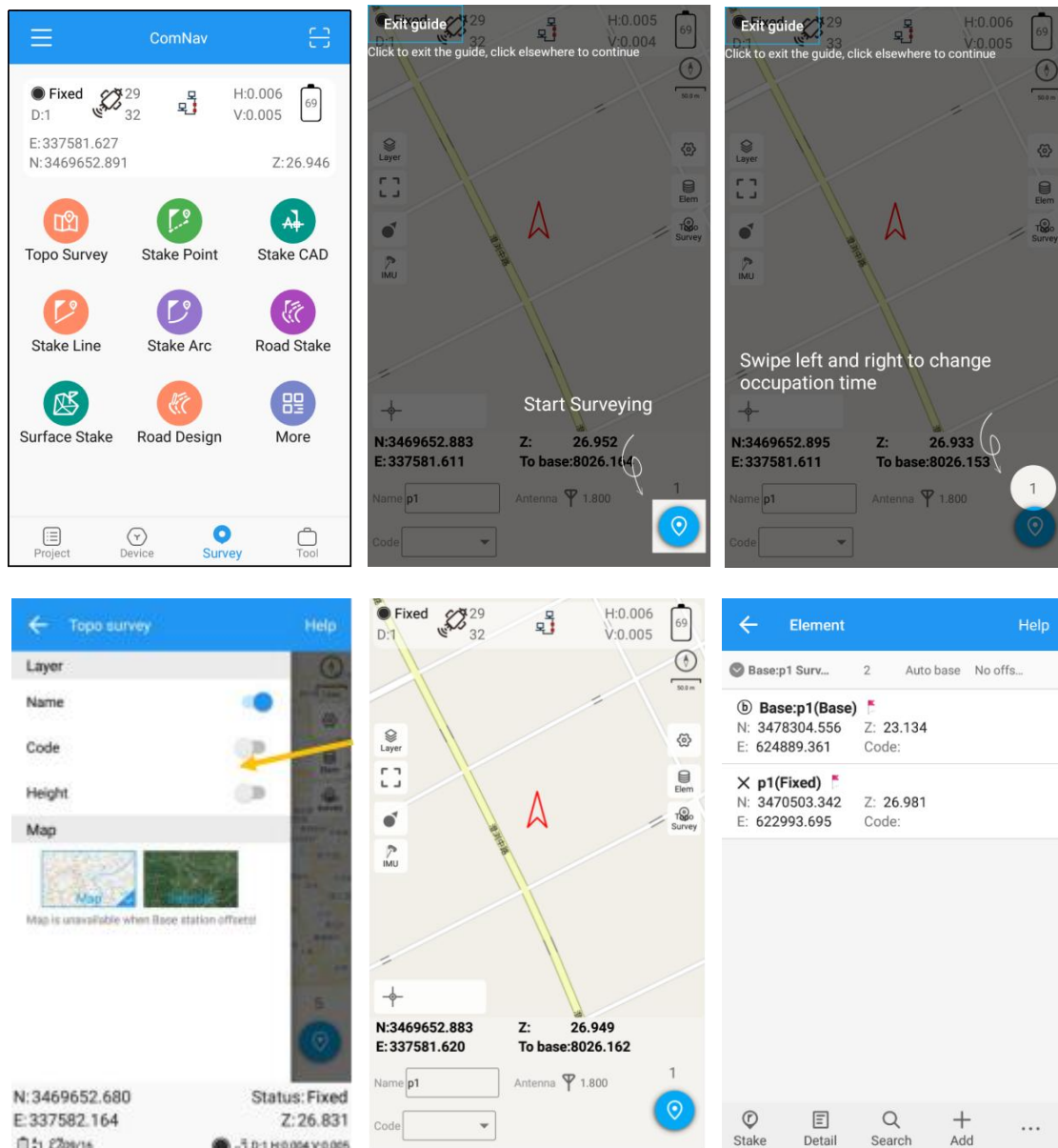

 : Click this to show the whole points on the interface.

 : If the arrow is out of sight on the interface, you can click this to locate the receiver position, then the arrow will be shown on the interface.

- Graphic survey: Tap the graphic button, after completing survey, will directly show the graphic on the map, you can export the graphic survey results as *.dxf format in Export interface.

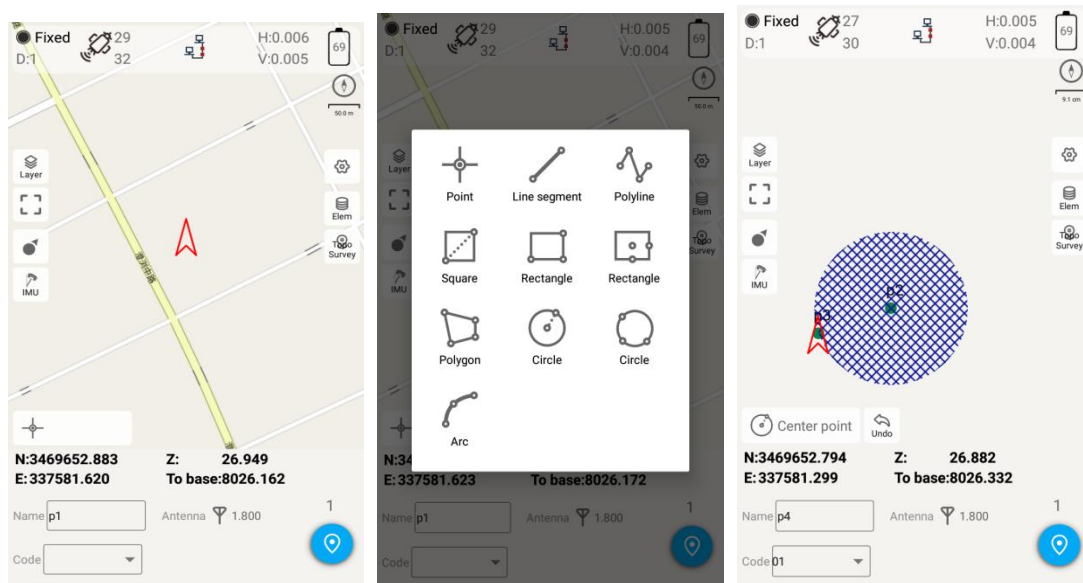

- Fast survey by pressing Code: Tap the code in nine panels, will survey the point directly.

- Go into code management interface to modify code list, then you can choose code to use in nine panels.

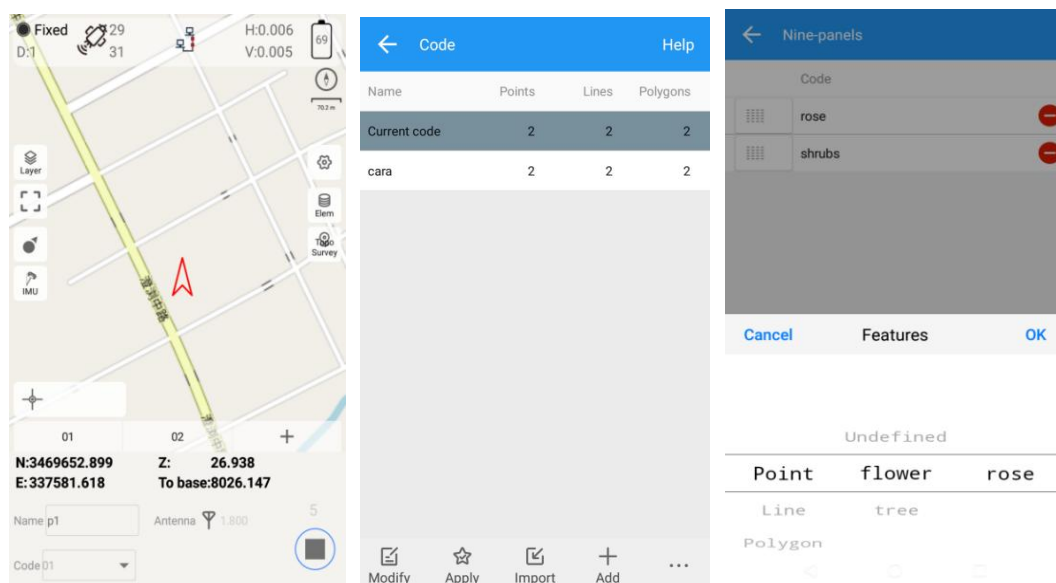

- Recover deleted points in Recycle Bin.

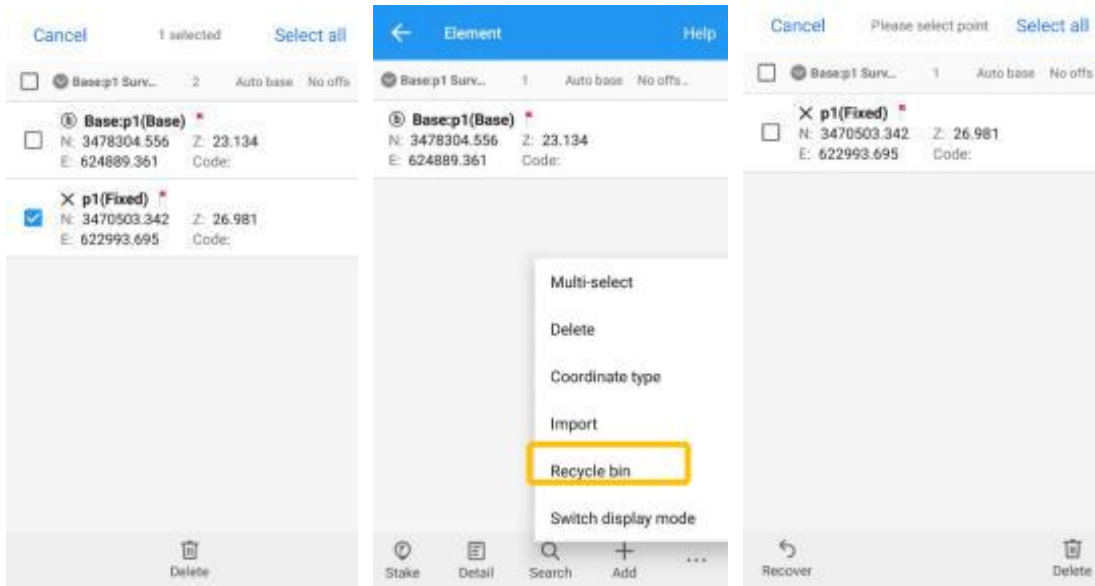

6.1.1 Survey settings

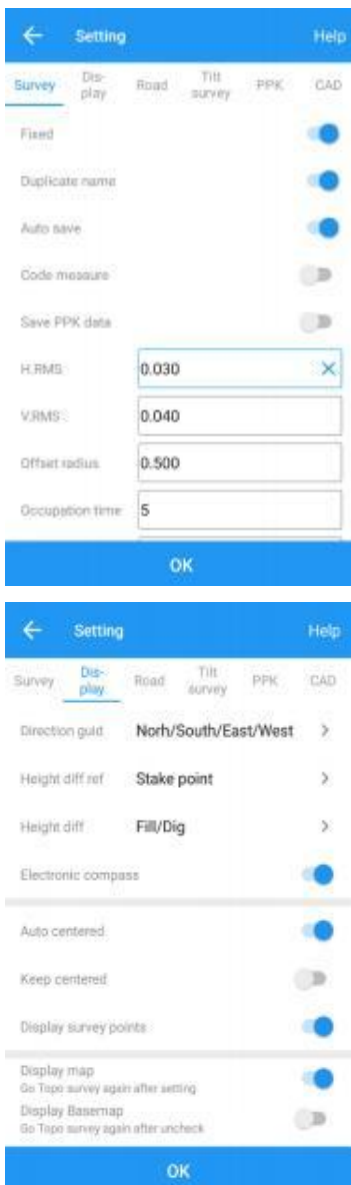

- Fixed: only fixed result can be saved;
- Duplicate name: allow point name same;
- RMS: point accuracy need higher than the value;
- Offset radius: point cannot offset bigger than the value during measure;
- Occupation time: measure times for one point;
- Point stepsize: for point name;
- Stake range: show circle when close to target point;

- Direction guide: 3 methods showing guide for stake out;
- Electronic compass: Use controller compass during stake out;
- Auto centered: Map will go to current location after 5 seconds;
- Keep centered: Map will go to current location after 1 second;
- Display survey points: will show all survey points on map;
- Display Basemap: for showing DXF/SHP file on map

6.1.2 Tilt survey

Tilt survey option will appear when receiver supports for tilt survey, it is available for ComNav Technology Mars Laser RTK, use IMU sensor.

According to the IMU sensor, can meets the requirement of high precision measurement. When the tilts within 60°, the built-in sensor based IMU precisely calculates the actual offset, which accuracy can up to 5.5 cm.

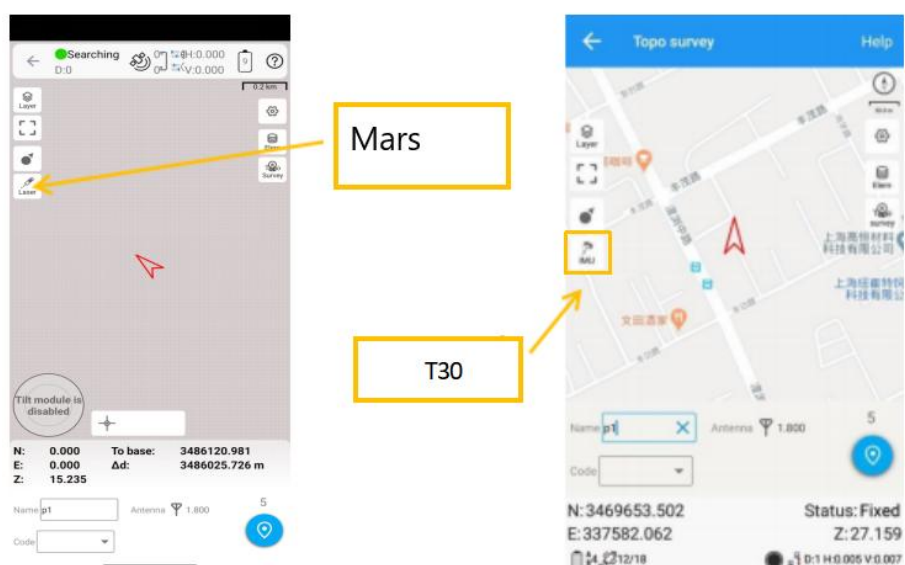

- ① Open Laser measurement from Tilt survey in setting



② Initialization

If you want to use laser, you just need to start laser mode in survey interface and follow the steps to initialize the IMU and laser. During operation, make receiver can search the satellites and get a fixed solution

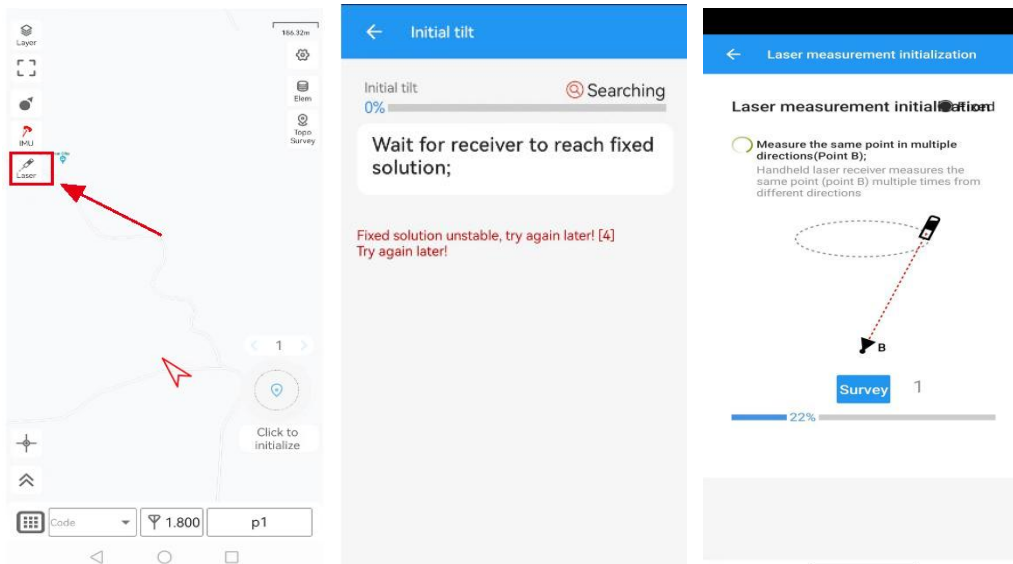

In survey interface, you can find the bubble and angle value shows the pole you tilt, also laser distance. For more accuracy, angle less than 60° will be better. And the laser icon will turn green, it means laser is ready to work.

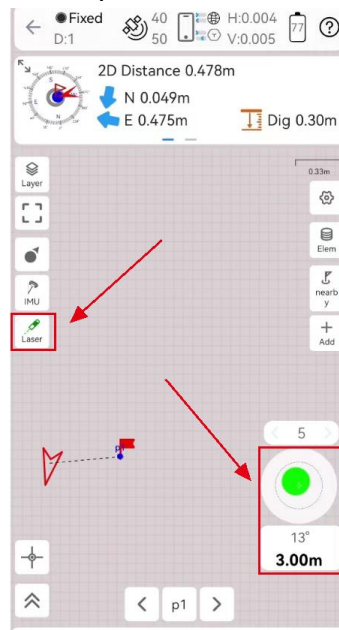



Tip: Do not shake or rotate the receiver violently, otherwise you need to re-initialize.

6.2 Auto survey/Area survey

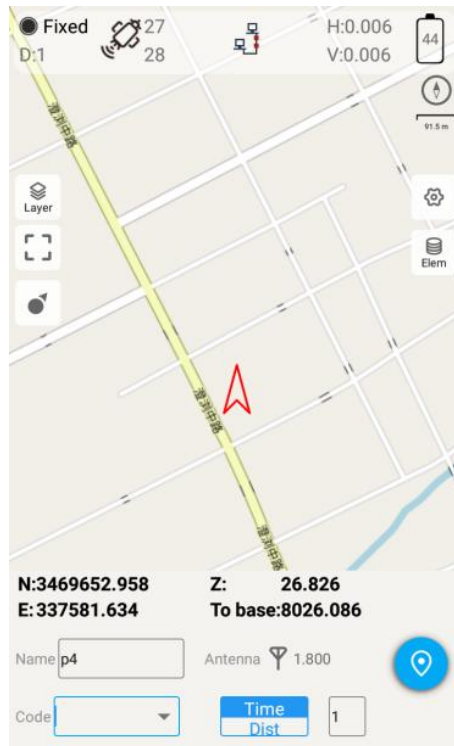
For Auto survey, it supports automatic and continuous survey according to Time or Distance.



For Area survey, it can compute area directly after getting points.

Press , it will show the coordinate information, press , it will show the area result, press , it will show the shape on map.

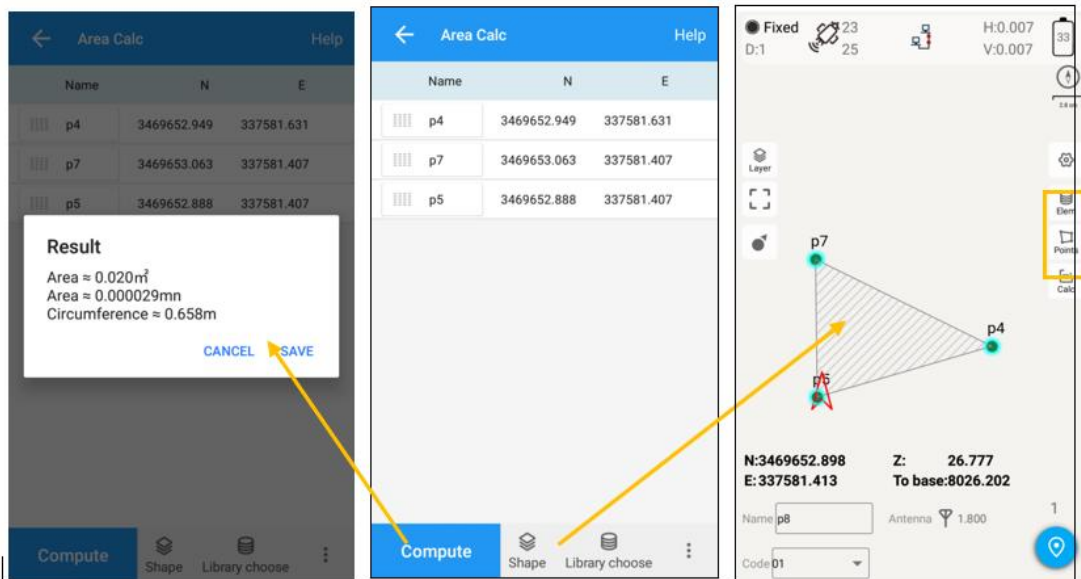

6.3 Stake points/lines

Go into **Stake point** interface, click to choose a point and tap **Stake**. Survey Master provides a navigation map when staking points/lines. If you are close to the target point enough, it will alarm you based on the alarm range you set.

Enter the point name and code based on your requirements, then click 

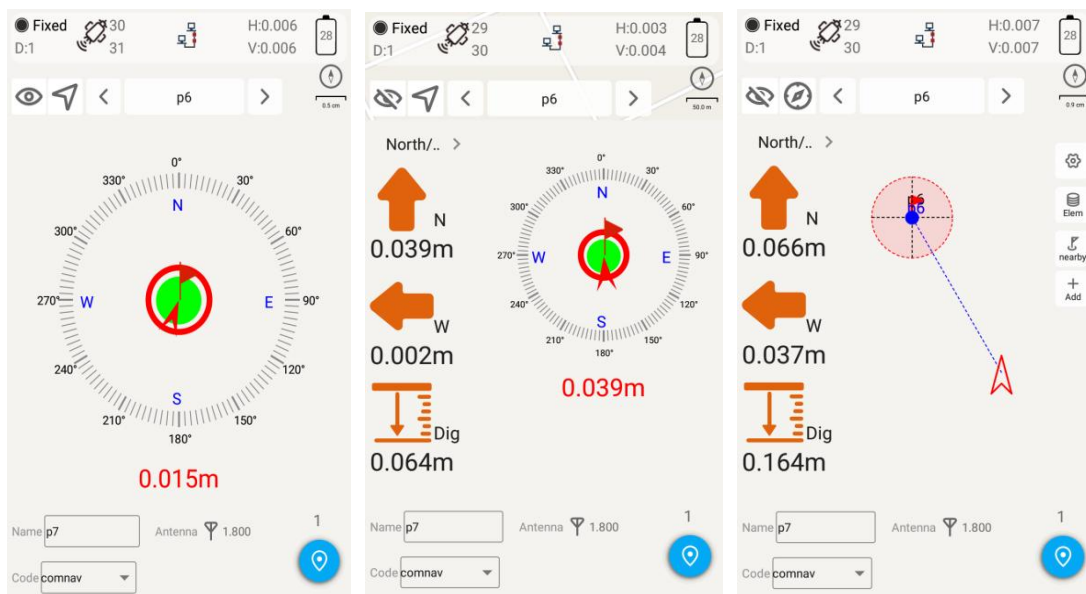
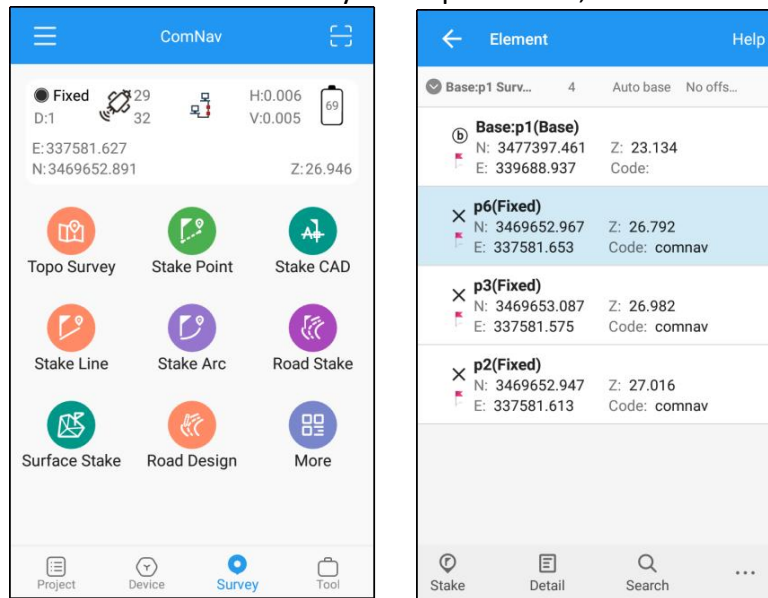

Various navigation info choices

You can also **Import** points for staking, or add from **Library choose**.

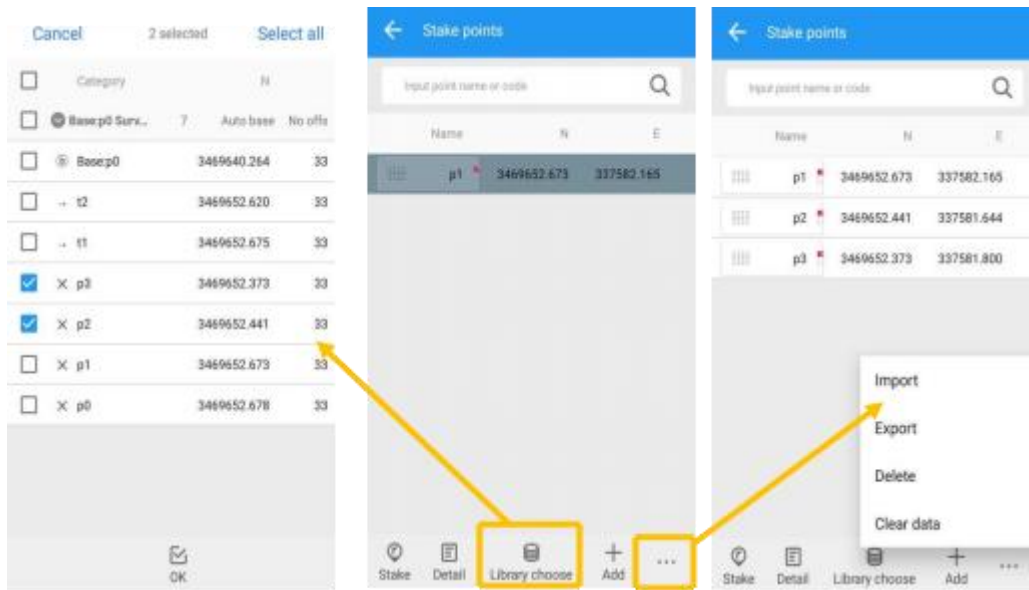

Tip: keep your receiver vertical to the ground.

For staking lines, click -> add line (Two points or Point + Azimuth + Distance) -> click -> Choose one line and click Stake. The default method to stake is "To line", press method to choose a method you want.

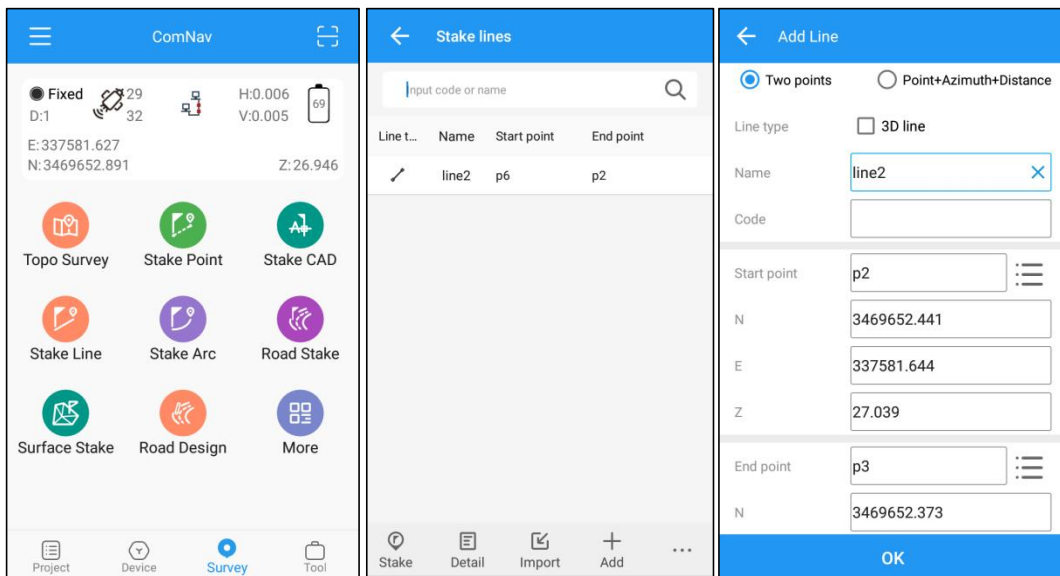

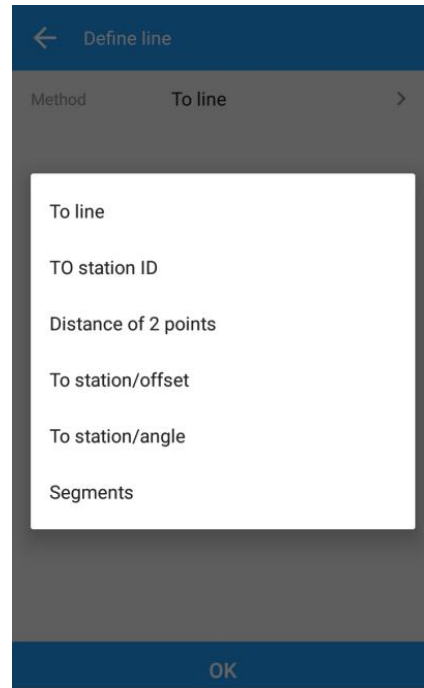
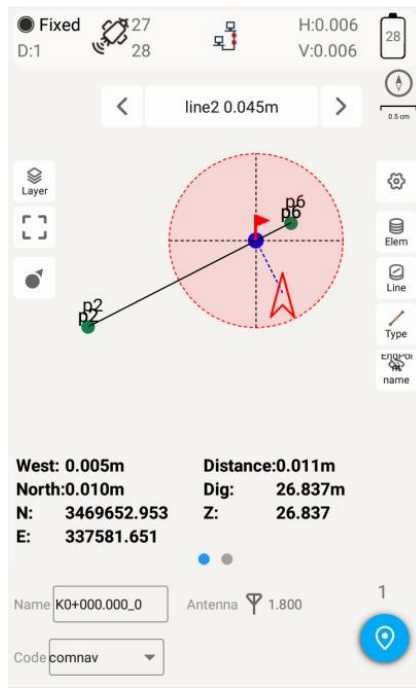



- To line: show shortest way to find a point on line;
- To station ID: stake points on line by defined interval;
- Distance of 2 points: show distance of current location to the line's start point and end point;
- Segment: Stake on line by defined segment value.

6.4 PPK

PPK (post processing kinetic) is the unique function of survey master, which is used for post-processing dynamic measurements.

It also needs two receivers to work together, one work as Base to record static data, and Mars work as Rover as shown below.

1. Click PPK in survey interface -> choose or create a PPK file.
2. Go to settings, configure PPK settings based on your requirements.
3. To get stable epoch, click  to initialize ->  to start PPK survey.

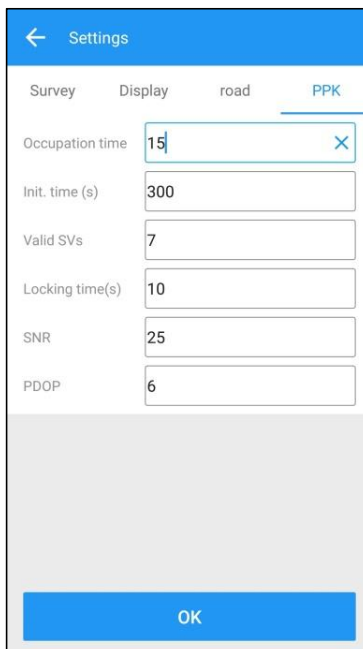
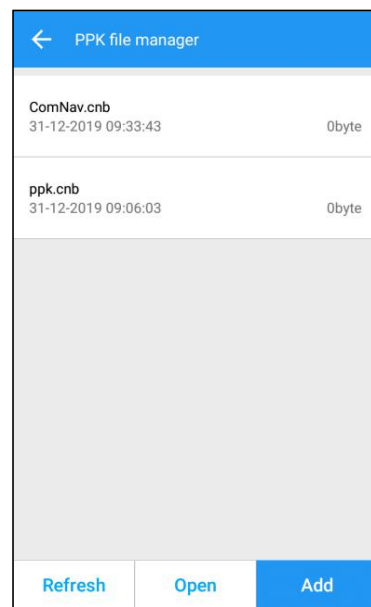
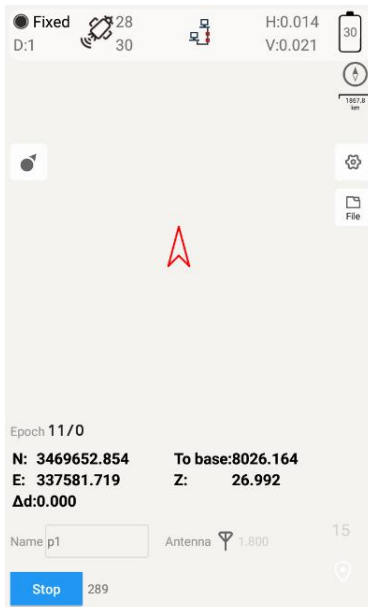
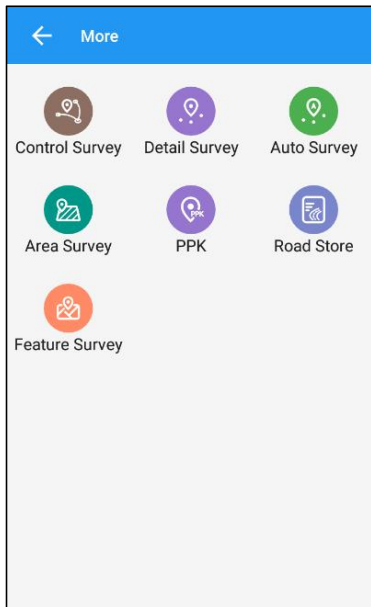

6.5 Site calibration/Grid Shift

6.5.1 Site calibration

Site calibration is commonly needed once in one project, and all the points will be collected based on calibrated datum system.

1. Choose manual pair or auto pair.

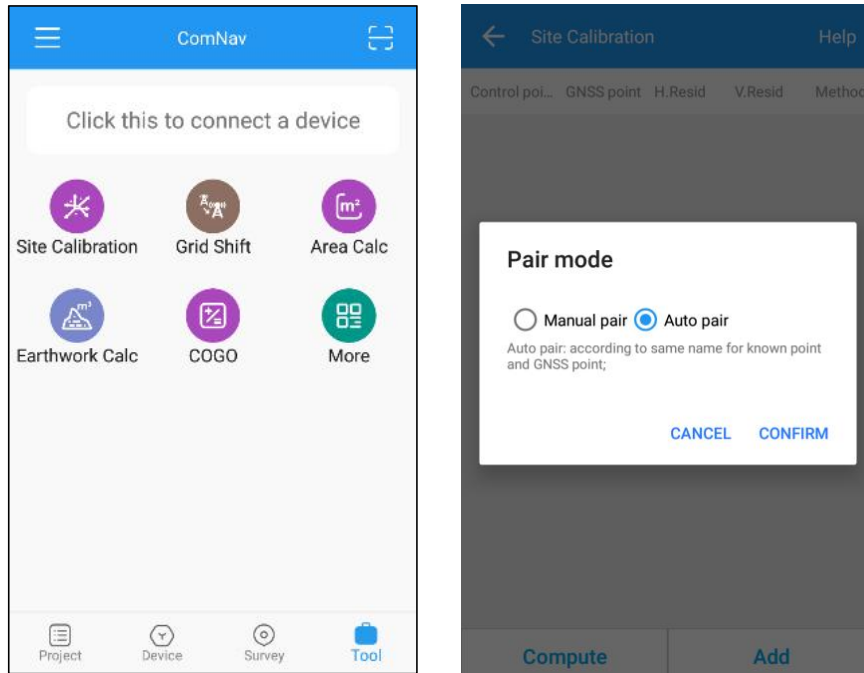

2. If you choose manual pair, you can directly enter at least three groups' point to compute. (for example, take K1,K2,K3 as known points, take A1,A2,A3 as measured points) After click Compute to calculate, the software will calibrate automatically.

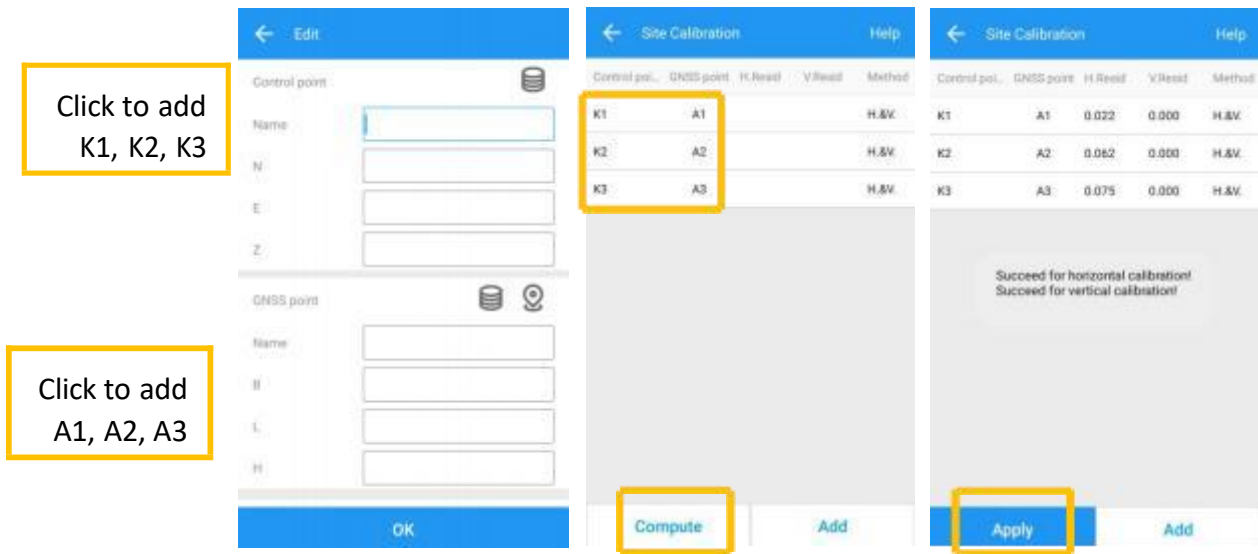

3. If you choose auto pair, it will auto compute according to the same name for known point and measured point. After click **Compute** to calculate, the software will calibrate automatically.

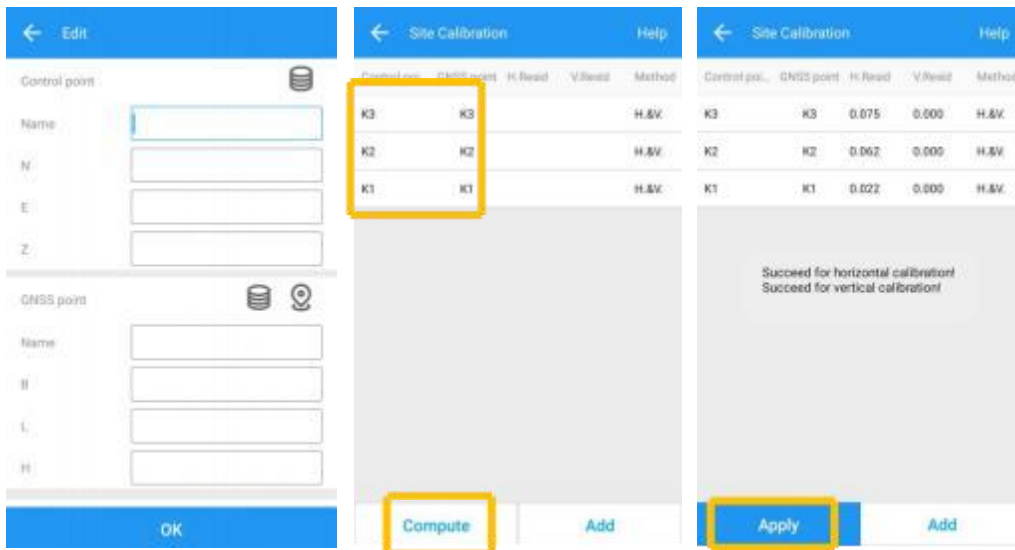

4. Click **Apply** to confirm to replace datum. The value of H.Resid and V.Resid should meet the requirement ($H.Resid \leq 0.015m$, and $V.Resid \leq 0.02m$).



6.5.2 Grid Shift

Grid reset function is applied when you need to change the position of Base station in the same project.

Click **Grid Shift** in Survey interface -> add current Base point and target Base point -> Click **Compute** -> Apply to complete grid shift.

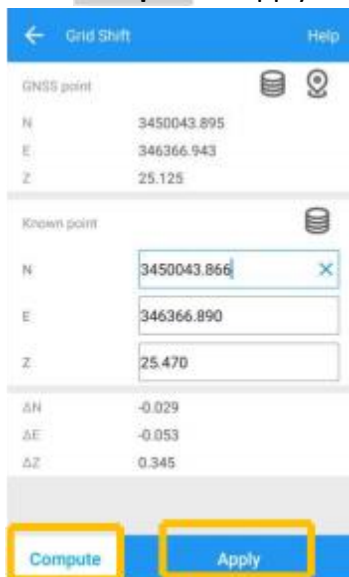

Click to add the point from one Base

Click to select the same point from another

6.6 COGO

With COGO function, you can calculate points/lines/angle directly on field.

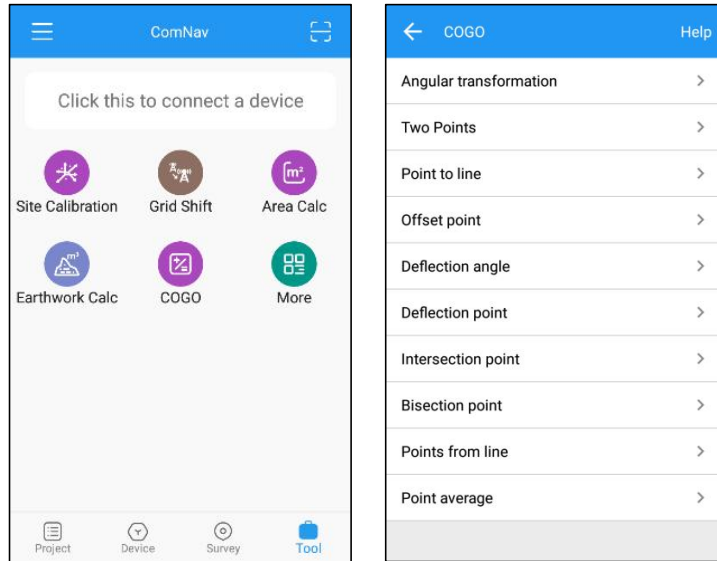

- Angular transformation: Angular type transform;
- Two points: Calculate two points distance;
- Point to line: Distance from point to one line;
- Offset point: Calculate point with azimuth and distance;
- Deflection angle: Calculate angle of two lines;
- Deflection point: Calculate point with angle and distance;
- Intersection point: Calculate intersection points from two lines;
- Bisection point: Calculate point from angle bisector;
- Points from line: Calculate points on line by distance or segment;
- Point average: Calculate average from points;

7. Data Export/Import

Survey Master supports to import/export data including grid coordinate, Lat/Lon coordinate with various data format, support import DXF/DWG file and export result of DXF/KML, etc.

7.1 Import

Tap **Import** in project interface, there are some predefined data formats, click **More** formats to get more predefined formats. Besides, you can click **Add** to create a User-defined type.

Long press the predefined data format that you don't use often, you can move this format to the More formats page; also, you can move the data format of More formats page to the previous page where stored the formats you usually use.

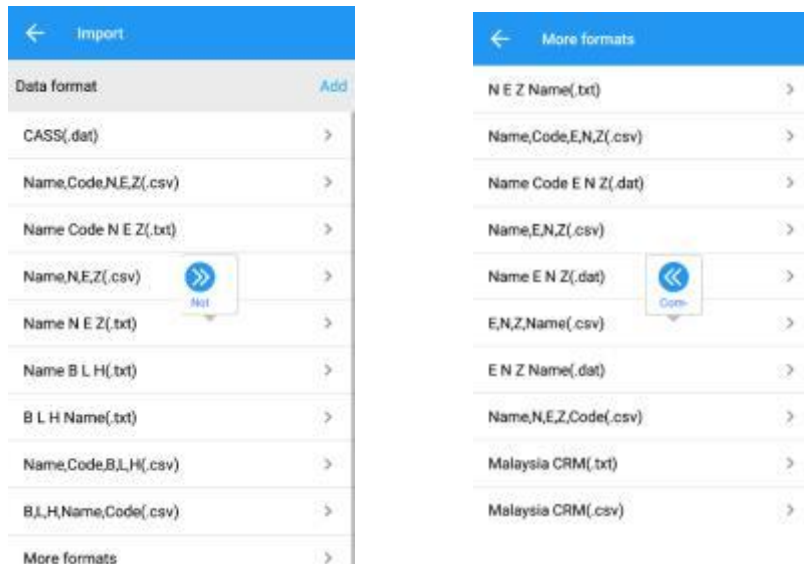

- Name: Enter the name for the format
- Delimiter: support Comma(,), Space(), Semicolon(;))
- File format: support *.csv, *.dat, *.txt format

Click Select all to choose all elements, Click Clear to eliminate all elements selected.

The elements include: code, name, N, E, Z, B, L, H, X RMS, Y RMS, V.RMS, status, start time, occupation time, diff age, base ID, total AntHgt, Antenna height, measure type, antenna name, ending time, comment, RMS, PDOP, HDOP, VDOP, TDOP, GDOP, total SV, used SV, elevation, tilt offset, tilt angle, tilt distance

Tip: The format you defined will also be saved to Export interface.

Choose one format to import data.

- The default export path is .../Sinognss/sm/data, you can also click Upperfolder to change to any other path where the file is.
- Point type: support Input point, Control point, Stake point

7.2 Export

Tap **Export** in Project interface to export simple data of survey points. Also, click **More formats** to export the survey points with detailed information or other formats like stake points/lines, DXF, SHP, KML, RAW, RW5, HTML, CASS feature result.

Same with Import result, long press the predefined data format to select the interface you want to place.

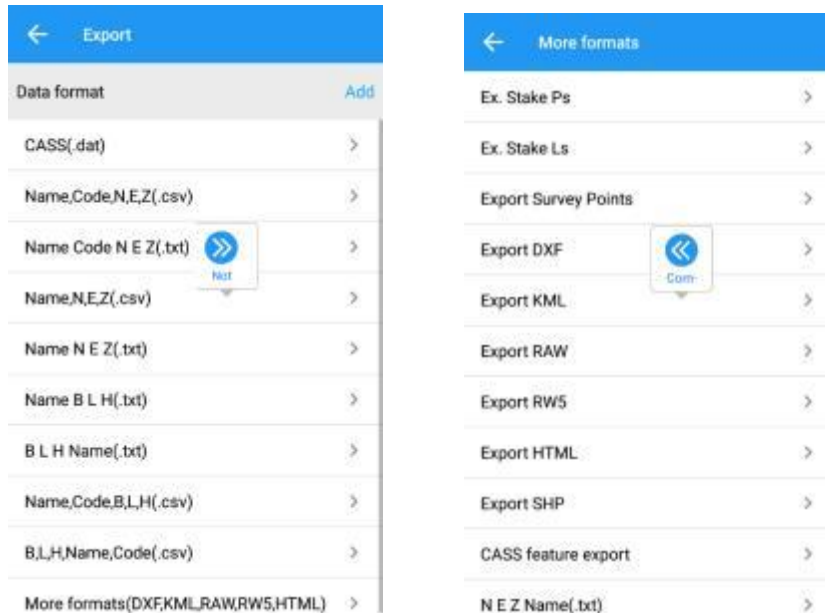

File format: support *.csv, *.dat, *.txt format choose one format to export data.

Select: support Survey point, Control point, Input point, Stake point, Base, also,you can set the data, name, code of data to specific export.

The default export path is [.../Sinognss/sm/export](#), and the previous saved file will be shown below, you can also click **Upper folder** to change to any other path.

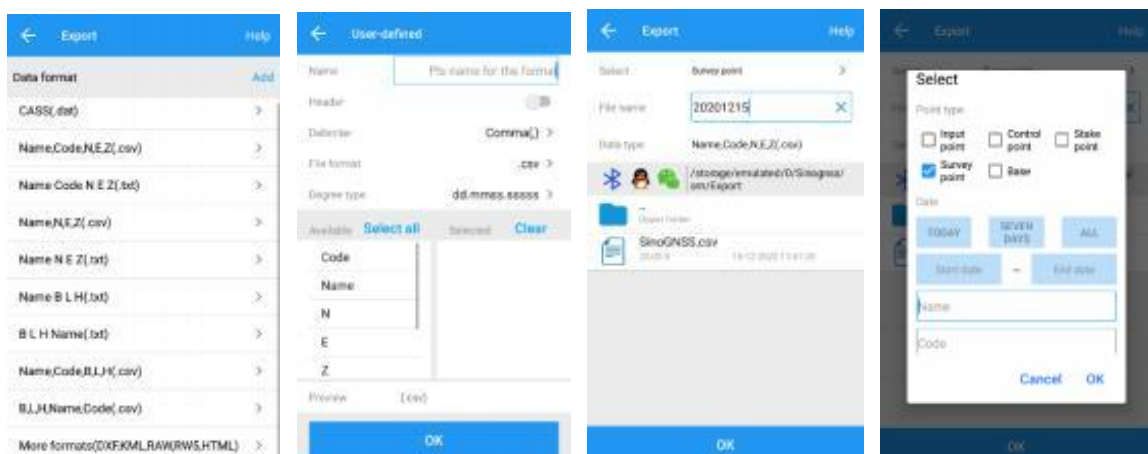

For the points, lines and polygons you surveyed in Topo survey and Feature survey, you can click **Export DXF** to export dxf file, then you can edit them in third party CAD software, or import to **Basemap** to check, or import to **Stake CAD** to stake.

Choose the data that you want to export including survey point, input point, control point, stake point, base, line and polygon, and the layer properties includes name, code and height, the default text height is 0.5.

The screenshot shows the 'Export DXF' dialog box. At the top, there is a blue header with a back arrow and the text 'Export DXF'. Below the header, the 'Path' is '/Sinognss/sm/Export'. The 'File name' field contains 'CornNav_dxf'. The 'Data' section has checkboxes for 'Survey point' (checked), 'Input point' (unchecked), 'Control point' (unchecked), and 'Stake point' (unchecked). The 'Layer' section has checkboxes for 'Base' (checked), 'Line' (checked), 'Polygon' (checked), 'Name' (checked), 'Code' (checked), and 'Height' (checked). The 'Text height' field is set to '0.500'. At the bottom, there is a blue 'OK' button.

7.3 Import Basemap

Tap **Basemap** to import DXF/DWG/SHP file into Survey Master.

- Add points: Save points from the dxf/dwg/shp file to element.
- Add lines: Save lines from the dxf/dwg/shp file to element.
- Prefix: Support add prefix name for points/lines saved to Elements.
- Add line endpoints: add line endpoints to point element.

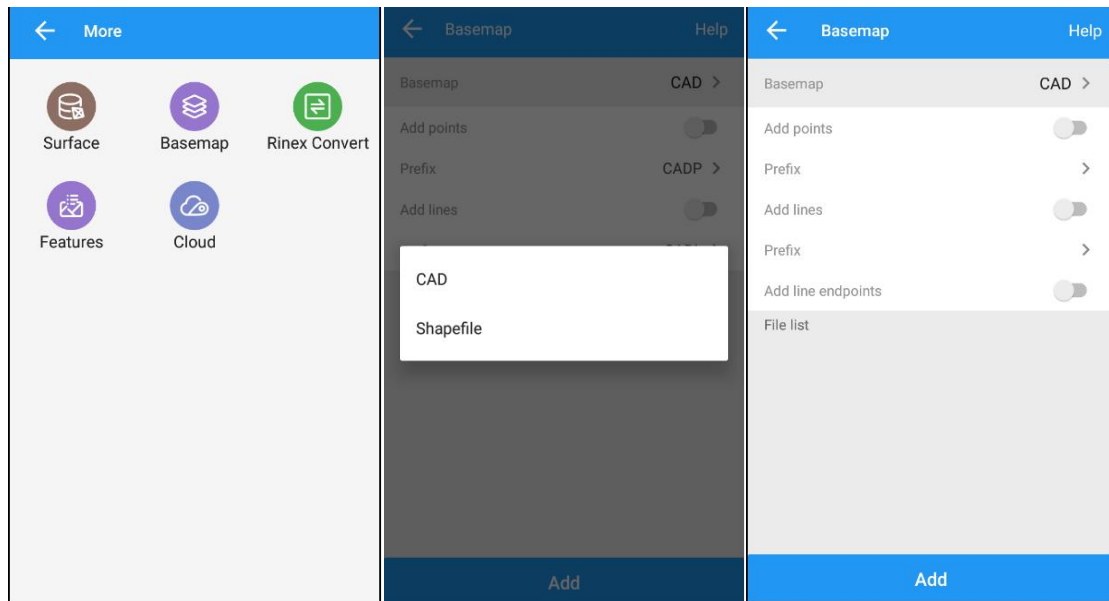

Remember go survey settings to check on display basemap, click zoom button to auto show basemap.

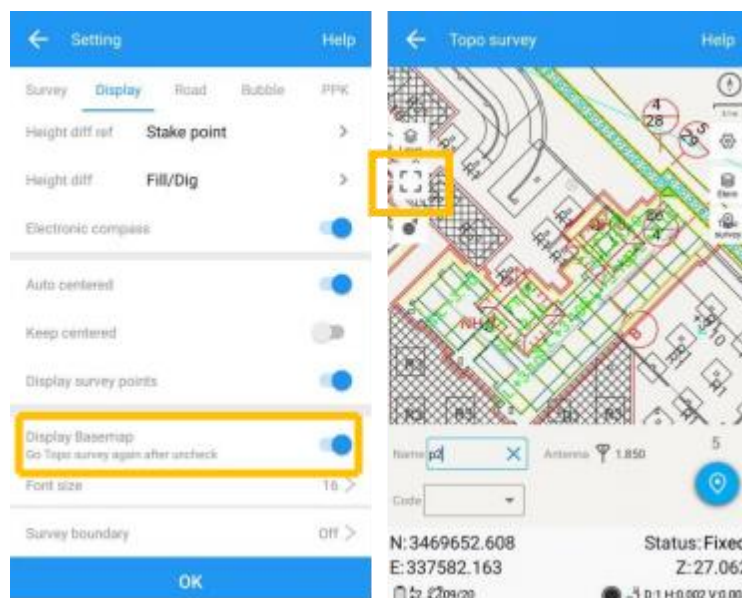

8. Export Result

8.1 NMEA 0183 output

With **NMEA 0183** function, you can quickly set to output NMEA data from lemo port or Bluetooth. In fact, this function is same as enter commands “log comX gpXXX ontime X”.

Choose NMEA Port -> Baud -> check commands you want to output.

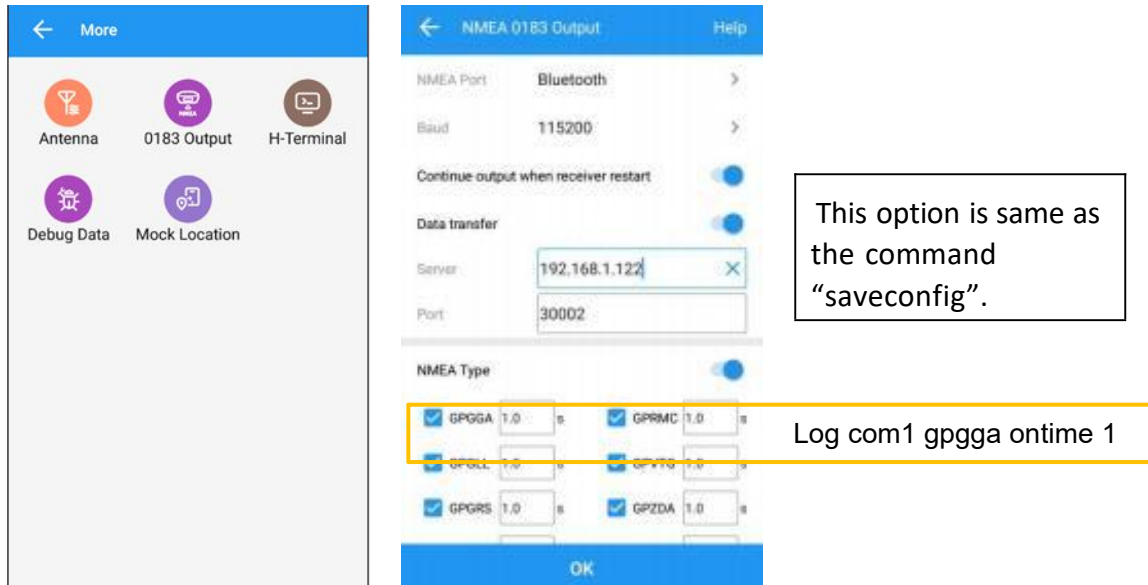

Data transfer: for transmit all the BT output to the address.

8.2 Register Mars via Survey Master

Normally, the register code is like this:

`ID:03401012 $$:49-0B-79-23-00-00-00-95-85`

`FUNCTIONREG:2207453726-3851620954-0949162572-0697504466-0613618189-0027539229`

Note: The length of code may different according to different requirements.

Following shows two methods to register the receiver.

➤ Register function

For Register function, you need only enter the number:

`2207453726-3851620954-0949162572-0697504466-0613618189-0027539229`

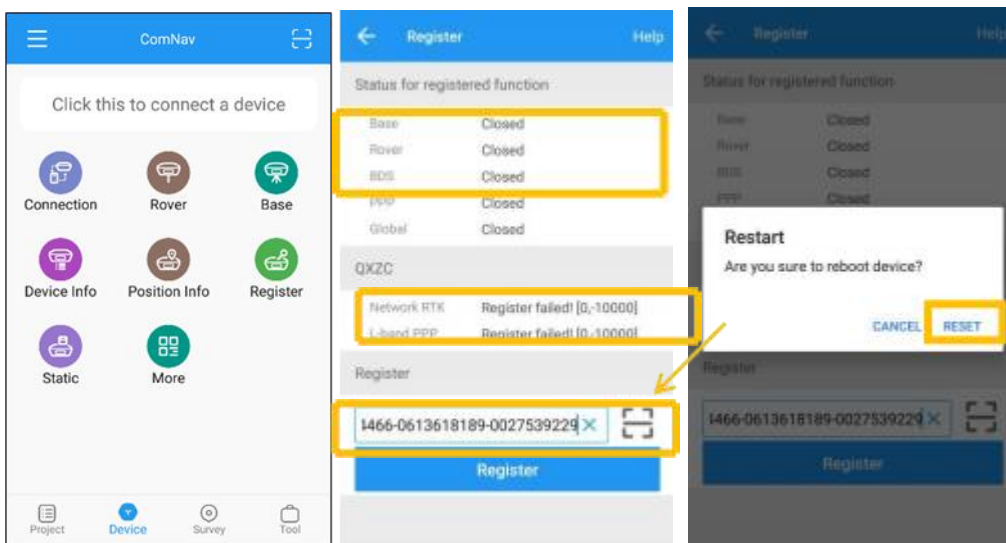

➤ Register via commands

You need copy the whole code, include the word 'FUNCTIONREG:'

`FUNCTIONREG:2207453726-3851620954-0949162572-0697504466-0613618189-0027539229`

Copy the whole code, and enter the cursor to next line, then send.

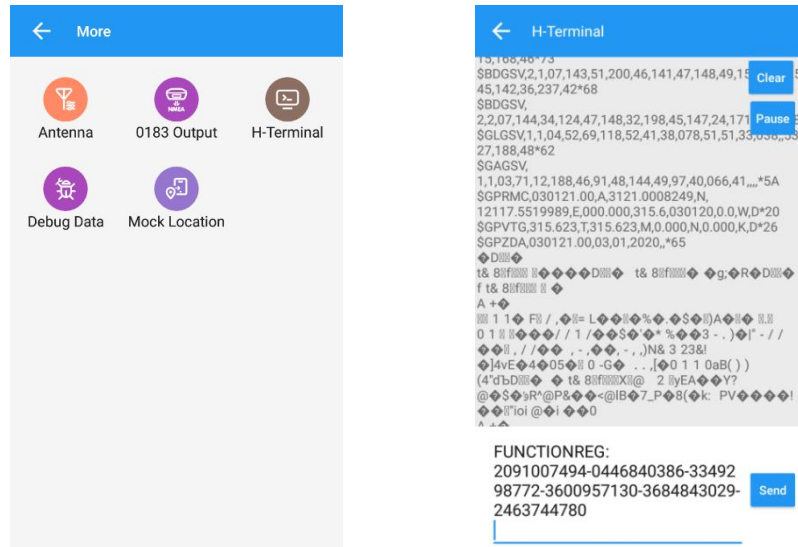

Send command: [LOG REGLIST](#)

To check receiver register status.

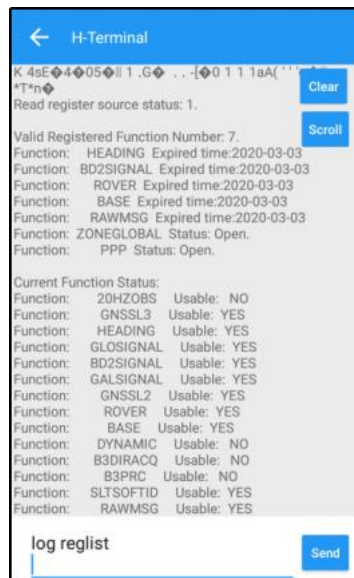

9. Firmware Upgrade

Prepare a USB-TypeC cable. And download a Driver of USB recognition. It's important.

Mars adopts the latest chip, integrated system and board, which shall be distinguished during upgrading. The latest version of the system is 1.1.0, and the board is 610QR

1. Copy the firmware software to your PC, connect Veuns to your PC via type-c cable and turn on the receiver.

2. Open the firmware program, select proper port to connect with receiver, click “Open”, only choose “OS” and “GNSS” and then click “Start”. Wait for a minute, it will be successful. It means that the system has been upgraded to 1.1.0, 610QR

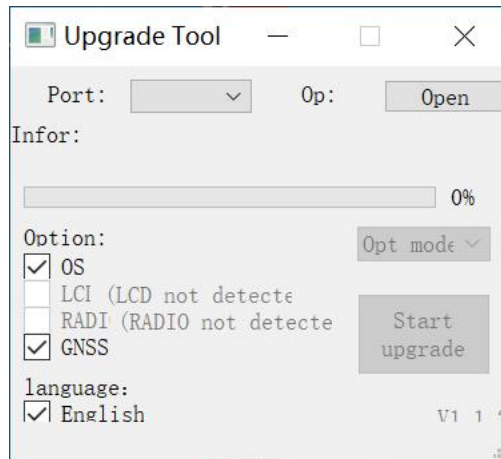

3. When the progress bar is full, and “Completed!” appear below, it seems the update has been completed and then you can disconnect it and wait for 1 minute to finish the update

Appendix A: 7-Pin Lemo definition

The following figures show the definition of 7-pin lemo, and the structure of 7-pin Lemo to RS232 Cable:

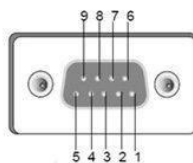

7 pin Lemo	Description
1	Signal GND
2	GND
3	TX data out (TXD)
4	NONE
5	NONE
6	Power In (+)
7	Serial data in

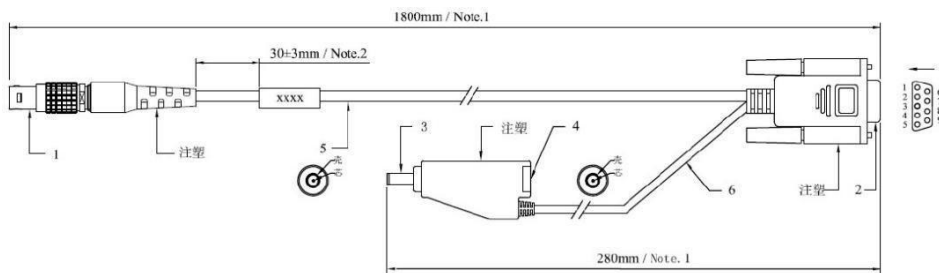

Appendix B: Physical Parameter of Modules inside of Mars

Radio:

Radio parameter	Specifications
Frequency range	410.125-469.625MHz
Protocol	Transparent
Airlink rate	9600 bps
Bandwidth	12.5kbps
Power	0.5, 1,
Work distance	10-15km, depends on power supply and environment condition
Modulation	GMSK/4FSK

Bluetooth:

Frequency Range: 2.402Ghz-2.480Ghz

FCC Warning

This device complies with part 15 of the FCC rules. Operation is subject to the following two conditions: (1) this device may not cause harmful interference, and (2) this device must accept any interference received, including interference that may cause undesired operation.

Changes or modifications not expressly approved by the party responsible for compliance could void the user's authority to operate the equipment.

NOTE: This equipment has been tested and found to comply with the limits for a Class B digital device, pursuant to part 15 of the FCC Rules. These limits are designed to provide reasonable protection against harmful interference in a residential installation. This equipment generates uses and can radiate radio frequency energy and, if not installed and used in accordance with the instructions, may cause harmful interference to radio communications. However, there is no guarantee that interference will not occur in a particular installation. If this equipment does cause harmful interference to radio or television reception, which can be determined by turning the equipment off and on, the user is encouraged to try to correct the interference by one or more of the following measures:

- Reorient or relocate the receiving antenna.
- Increase the separation between the equipment and receiver.
- Connect the equipment into an outlet on a circuit different from that to which the receiver is connected.
- Consult the dealer or an experienced radio/TV technician for help.

Radiation Exposure Statement

This equipment complies with FCC radiation exposure limits set forth for an uncontrolled environment. This equipment should be installed and operated with minimum distance 50cm between the radiator and your body.