

# FCC Radio Test Report

**FCC ID: HLZT7**

**Report No.** : BTL-FCCP-4-2311H013  
**Equipment** : Connect T7 Wi-Fi 7 Mesh Router  
**Model Name** : T7  
**Brand Name** : Predator  
**Applicant** : Acer Incorporated  
**Address** : 8F, 88, Sec. 1, Xintai 5th Rd., Xizhi, New Taipei City 221, Taiwan, R.O.C.

**Equipment Class** : 6ID - 15E 6 GHz Low Power Indoor Access Point

**Radio Function** : U-NII 6 GHz (U-NII 5, U-NII 6, U-NII 7, U-NII 8)

**FCC Rule Part(s)** : FCC CFR Title 47, Part 15, Subpart E (15.407)  
**Measurement Procedure(s)** : ANSI C63.10-2013

**Date of Receipt** : 2023/11/9  
**Date of Test** : 2023/12/4 ~ 2024/1/4  
**Issued Date** : 2024/6/24

The above equipment has been tested and found in compliance with the requirement of the above standards by BTL Inc.

**Prepared by**

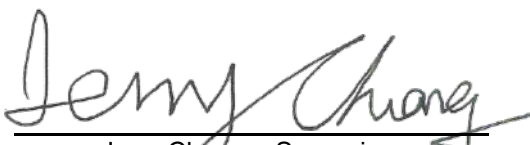
  
Jerry Chuang, Supervisor

**Approved by**

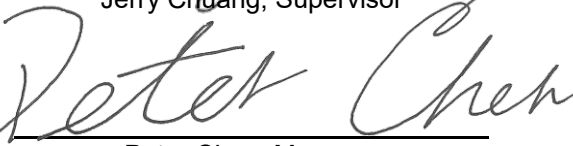
  
Peter Chen, Manager

**BTL Inc.**

No.18, Ln. 171, Sec. 2, Jiuzong Rd., Neihu Dist., Taipei City 114, Taiwan

Tel: +886-2-2657-3299 Fax: +886-2-2657-3331 Web: www.newbtl.com Service mail: btl\_qa@newbtl.com

**Declaration**

**BTL** represents to the client that testing is done in accordance with standard procedures as applicable and that test instruments used has been calibrated with standards traceable to international standard(s) and/or national standard(s).

**BTL's** reports apply only to the specific samples tested under conditions. It is manufacture's responsibility to ensure that additional production units of this model are manufactured with the identical electrical and mechanical components. **BTL** shall have no liability for any declarations, inferences or generalizations drawn by the client or others from **BTL** issued reports.

This report is the confidential property of the client. As a mutual protection to the clients, the public and ourselves, the test report shall not be reproduced, except in full, without our written approval.

**BTL's** laboratory quality assurance procedures are in compliance with the **ISO/IEC 17025** requirements, and accredited by the conformity assessment authorities listed in this test report.

**BTL** is not responsible for the sampling stage, so the results only apply to the sample as received.

The information, data and test plan are provided by manufacturer which may affect the validity of results, so it is manufacturer's responsibility to ensure that the apparatus meets the essential requirements of applied standards and in all the possible configurations as representative of its intended use.

**Limitation**

For the use of the authority's logo is limited unless the Test Standard(s)/Scope(s)/Item(s) mentioned in this test report is (are) included in the conformity assessment authorities acceptance respective.

Please note that the measurement uncertainty is provided for informational purpose only and are not use in determining the Pass/Fail results.

## CONTENTS

REVISION HISTORY	5
1 SUMMARY OF TEST RESULTS	6
1.1 TEST FACILITY	7
1.2 MEASUREMENT UNCERTAINTY	7
1.3 TEST ENVIRONMENT CONDITIONS	7
1.4 DUTY CYCLE	8
2 GENERAL INFORMATION	10
2.1 EUT INFORMATION	10
2.2 TEST MODES	15
2.3 TESTED CONFIGURATION DIAGRAM	17
2.4 SUPPORT UNITS	18
3 MAXIMUM E.I.R.P. TEST	19
3.1 LIMITS	19
3.2 TEST PROCEDURE	19
3.3 DEVIATION FROM TEST STANDARD	21
3.4 TEST SETUP	21
3.5 EUT OPERATING CONDITIONS	21
3.6 TEST RESULT	21
4 MAXIMUM TRANSMITTER CHANNEL BANDWIDTH TEST	22
4.1 LIMITS	22
4.2 TEST PROCEDURE	22
4.3 DEVIATION FROM TEST STANDARD	23
4.4 TEST SETUP	23
4.5 EUT OPERATING CONDITIONS	23
4.6 TEST RESULT	23
5 MAXIMUM POWER SPECTRAL DENSITY TEST	24
5.1 LIMITS	24
5.2 TEST PROCEDURE	24
5.3 DEVIATION FROM TEST STANDARD	25
5.4 TEST SETUP	25
5.5 EUT OPERATING CONDITIONS	25
5.6 TEST RESULT	25
6 UNDESIRABLE EMISSIONS TEST	26
6.1 LIMITS	26
6.2 TEST PROCEDURE	27
6.3 DEVIATION FROM TEST STANDARD	28
6.4 TEST SETUP	28
6.5 EUT OPERATING CONDITIONS	29
6.6 TEST RESULT – 9KHZ TO 30 MHZ	29
6.7 TEST RESULT – 30 MHZ TO 1 GHZ	29
6.8 TEST RESULT – ABOVE 1 GHZ	29
7 IN-BAND EMISSION (MASK) TEST	30
7.1 LIMITS	30
7.2 TEST PROCEDURE	30
7.3 DEVIATION FROM TEST STANDARD	31
7.4 TEST SETUP	31

7.5	EUT OPERATING CONDITIONS	31
7.6	TEST RESULT	31
8	AC POWER LINE CONDUCTED EMISSIONS TEST	32
8.1	LIMITS	32
8.2	TEST PROCEDURE	32
8.3	DEVIATION FROM TEST STANDARD	33
8.4	TEST SETUP	33
8.5	EUT OPERATING CONDITIONS	33
8.6	TEST RESULT	33
9	CONTENTION-BASED PROTOCOL TEST	34
9.1	LIMITS	34
9.2	TEST PROCEDURE	34
9.3	DEVIATION FROM TEST STANDARD	35
9.4	TEST SETUP	36
9.5	EUT OPERATING CONDITIONS	36
9.6	TEST RESULT	36
10	LIST OF MEASURING EQUIPMENTS	37
11	EUT TEST PHOTOS	38
12	EUT PHOTOS	38
APPENDIX A	MAXIMUM E.I.R.P.	39
APPENDIX B	MAXIMUM TRANSMITTER CHANNEL BANDWIDTH	60
APPENDIX C	MAXIMUM POWER SPECTRAL DENSITY	97
APPENDIX D	UNDESIRABLE EMISSIONS - 9 KHZ TO 30 MHZ	140
APPENDIX E	UNDESIRABLE EMISSIONS - 30 MHZ TO 1 GHZ	145
APPENDIX F	UNDESIRABLE EMISSIONS - ABOVE 1 GHZ	148
APPENDIX G	IN-BAND EMISSION (MASK)	379
APPENDIX H	AC POWER LINE CONDUCTED EMISSIONS	402
APPENDIX I	CONTENTION-BASED PROTOCOL	407

### REVISION HISTORY

Report No.	Version	Description	Issued Date	Note
BTL-FCCP-4-2311H013	R00	Original Report.	2024/5/20	Invalid
BTL-FCCP-4-2311H013	R01	Revised report to address comments.	2024/6/12	Invalid
BTL-FCCP-4-2311H013	R02	Revised report to address comments.	2024/6/24	Valid

## 1 SUMMARY OF TEST RESULTS

Test procedures according to the technical standards.

Standard(s) Section	Description	Test Result	Judgment	Remark
15.203 15.407(a)(9)	Antenna requirement	-----	Pass	-----
15.407(a)(4)(5)(6)(7)(8)	Maximum e.i.r.p.	APPENDIX A	Pass	-----
15.407(a)(10)	Maximum transmitter channel bandwidth	APPENDIX B	Pass	-----
15.407(a)(12)	Maximum power spectral density	APPENDIX C	Pass	-----
15.407(b)(6)(9)	Undesirable emissions	APPENDIX E APPENDIX F	Pass	-----
15.407(b)(7)	In-band emission (Mask)	APPENDIX G	Pass	-----
15.407(b)(9)	AC power line conducted emissions	APPENDIX H	Pass	-----
15.407(b)(10)	Restricted bands of operation	-----	Pass	-----
15.407(c)	Automatically discontinue transmission	-----	Pass	<b>NOTE (3)</b>
15.407(d)	Operational restrictions for 6 GHz U-NII devices	-----	Pass	<b>NOTE (4)</b>
15.407(d)(6)	Contention-based protocol	APPENDIX I	Pass	<b>NOTE (5)</b>
15.407(g) 2.1055	Frequency stability	-----	Pass	<b>NOTE (4)</b>

**NOTE:**

- (1) "N/A" denotes test is not applicable in this Test Report.
- (2) The report format version is TP.1.1.1.
- (3) The EUT can detect the controlling signal of ACK message transmitting from remote device and verify whether it shall resend or discontinue transmission.
- (4) Declaration by manufacturer.
- (5) Contention-Based Protocol Uses conducted method for testing.

### 1.1 TEST FACILITY

The test locations stated below are under the TAF Accreditation Number 0659.

The test location(s) used to collect the test data in this report are:

No. 68-1, Ln. 169, Sec. 2, Datong Rd., Xizhi Dist., New Taipei City 221, Taiwan  
(FCC DN: TW0659)

C05       CB08       CB11       SR10       SR11

No. 72, Ln. 169, Sec. 2, Datong Rd., Xizhi Dist., New Taipei City 221, Taiwan  
(FCC DN: TW0659)

C06       CB21       CB22

### 1.2 MEASUREMENT UNCERTAINTY

The reported uncertainty of measurement  $y \pm U$ , where expanded uncertainty  $U$  is based on a standard uncertainty multiplied by a coverage factor of  $k = 2$ , providing a level of confidence of approximately **95 %**.

The measurement instrumentation uncertainty considerations contained in CISPR 16-4-2. The BTL measurement uncertainty is less than the CISPR 16-4-2  $U_{\text{cispr}}$  requirement.

#### A. Conducted test:

Test Item	U (dB)
Maximum e.i.r.p.	0.3669
Maximum transmitter channel bandwidth	0.5332
Maximum power spectral density	0.6590
In-band emission (Mask)	-
Contention-based protocol	-
Frequency stability	0.5333

#### B. Undesirable emissions test:

Test Site	Measurement Frequency Range	U (dB)
CB21	0.03 GHz ~ 0.2 GHz	4.17
	0.2 GHz ~ 1 GHz	4.72
	1 GHz ~ 6 GHz	5.21
	6 GHz ~ 18 GHz	5.51
	18 GHz ~ 26 GHz	3.69
	26 GHz ~ 40 GHz	4.23

#### C. AC power line conducted emissions test:

Test Site	Method	Measurement Frequency Range	U (dB)
C05	CISPR	150 kHz ~ 30MHz	3.44

#### NOTE:

Unless specifically mentioned, the uncertainty of measurement has not been taken into account to declare the compliance or non-compliance to the specification.

### 1.3 TEST ENVIRONMENT CONDITIONS

Test Item	Environment Condition	Test Voltage	Tested by
Maximum e.i.r.p.	21.3 °C, 58 %	AC 120V	Jerry Chuang
Maximum transmitter channel bandwidth	21.3 °C, 58 %	AC 120V	Jerry Chuang
Maximum power spectral density	21.3 °C, 58 %	AC 120V	Jerry Chuang
Undesirable emissions below 1 GHz	Refer to data	AC 120V	Kevin Zhen
Undesirable emissions above 1 GHz	Refer to data	AC 120V	Kevin Zhen
In-band emission (Mask)	21.3 °C, 58 %	AC 120V	Jerry Chuang
AC power line conducted emissions	17 °C, 69 %	AC 120V	Ken Lan
Contention-based protocol	24.2 °C, 52 %	AC 120V	Cora Lin

## 1.4 DUTY CYCLE

If duty cycle is  $\geq 98\%$ , duty factor is not required.  
 If duty cycle is  $< 98\%$ , duty factor shall be considered.

Remark	Delta 1			Delta 2	On Time/Period	10 log(1/Duty Cycle)	1/On Time (B)
Mode	ON (ms)	Numbers (ON)	On Time (B) (ms)	Period (ON+OFF) (ms)	Duty Cycle (%)	Duty Factor (dB)	1/B Minimum VBW (kHz)
IEEE 802.11ax (HE20)	5.100	1	5.100	5.420	94.10%	0.26	0.196
IEEE 802.11ax (HE40)	5.280	1	5.280	5.420	97.42%	0.11	0.189
IEEE 802.11ax (HE80)	5.320	1	5.320	5.620	94.66%	0.24	0.188
IEEE 802.11ax (HE160)	5.160	1	5.160	5.380	95.91%	0.18	0.194
IEEE 802.11be (EHT20)	5.100	1	5.100	5.300	96.23%	0.17	0.196
IEEE 802.11be (EHT40)	5.280	1	5.280	5.440	97.06%	0.13	0.189

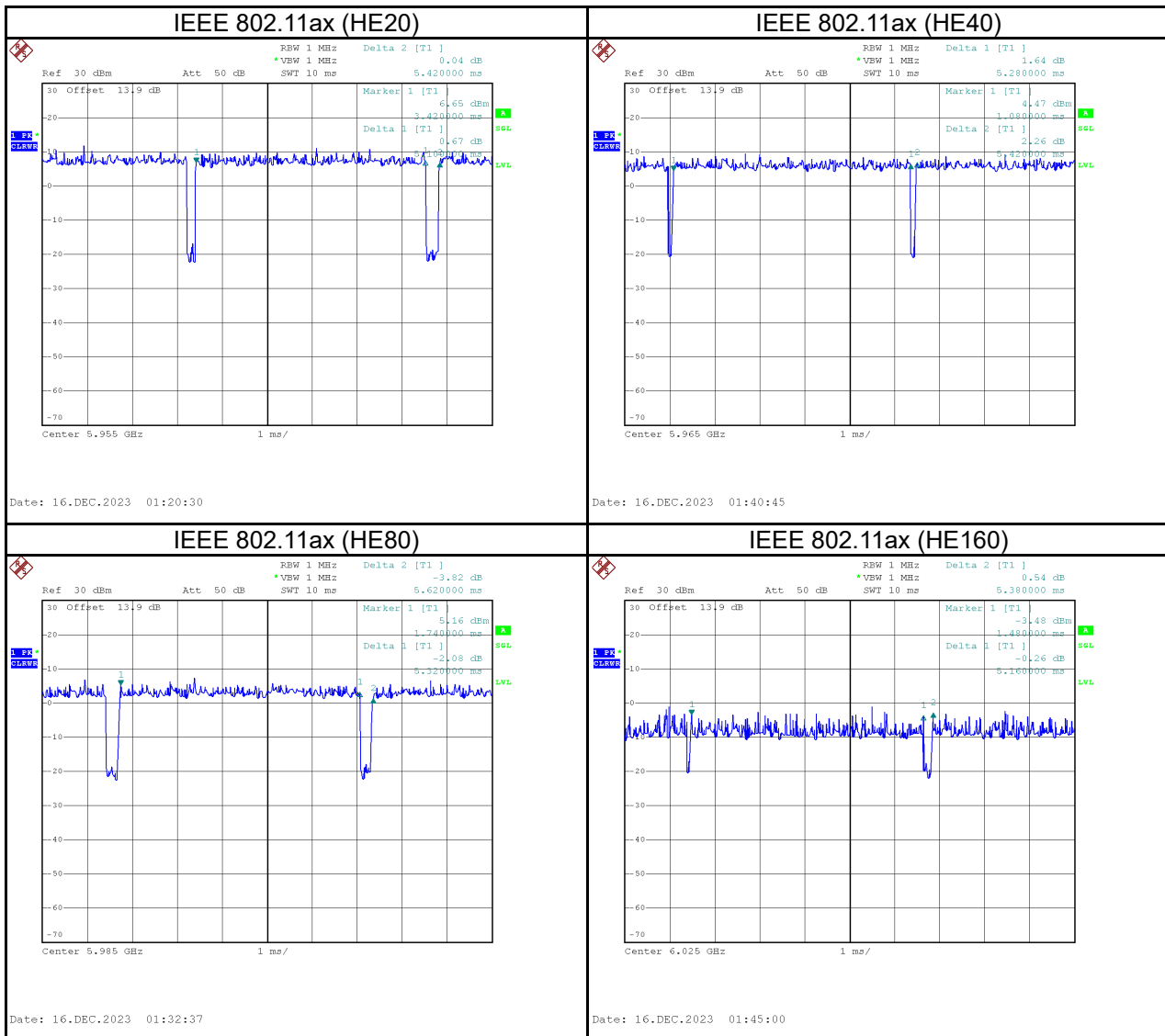



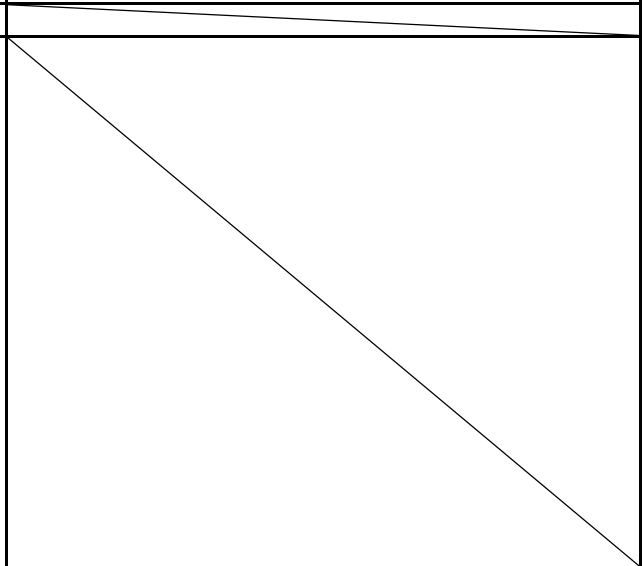
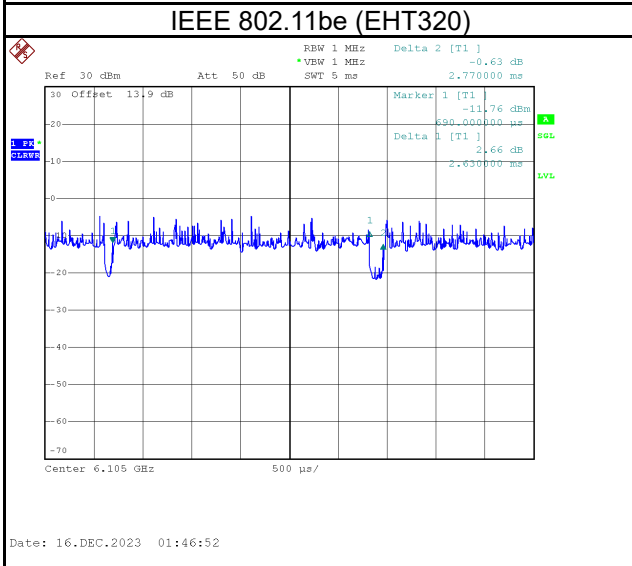
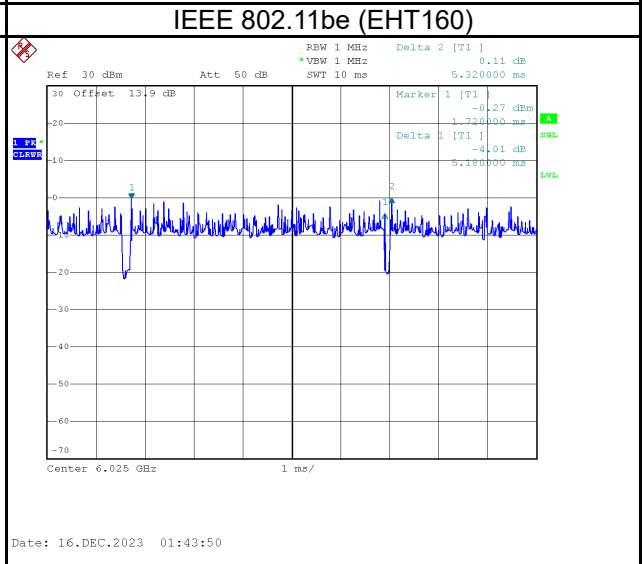
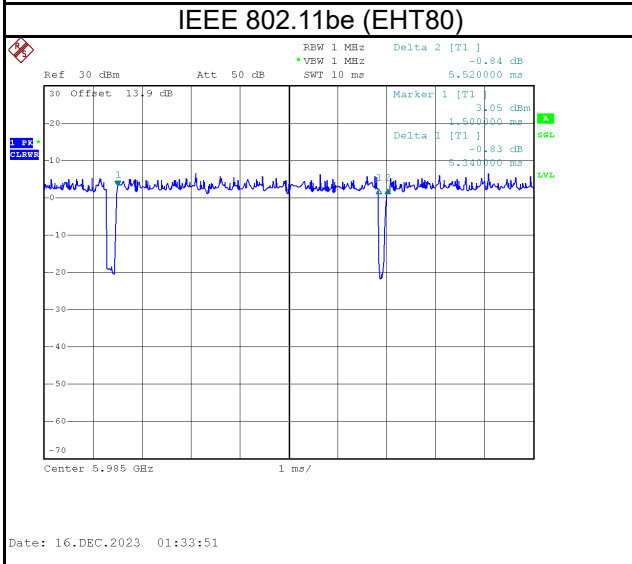
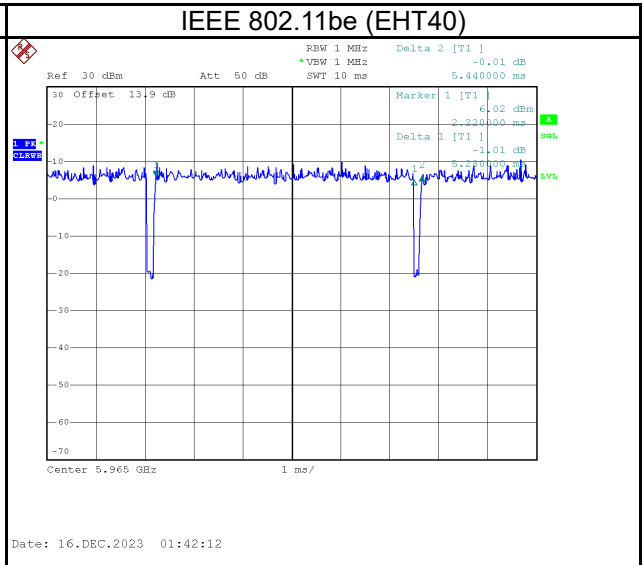
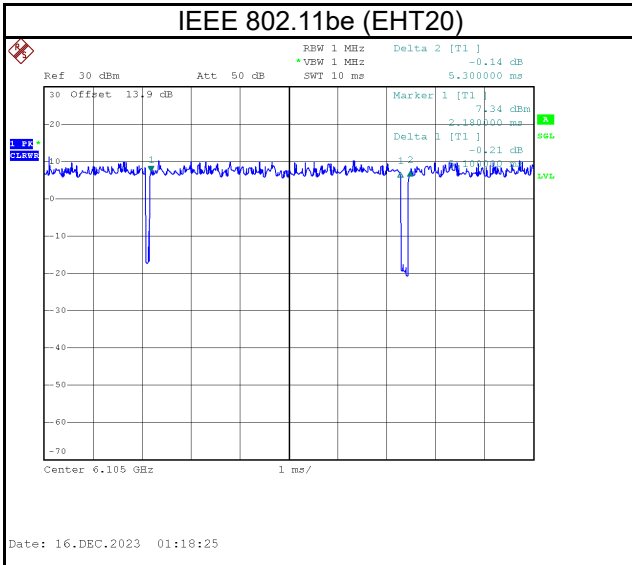

## 2 GENERAL INFORMATION

### 2.1 EUT INFORMATION

Equipment	Connect T7 Wi-Fi 7 Mesh Router
Model Name	T7
Brand Name	Predator
Model Difference	N/A
Power Source	DC voltage supplied from AC/DC Adapter.
Power Rating	I/P: 100-240V~50/60Hz 1.2A O/P: 12.0V--- 3.0A
Products Covered	1 * Adapter: TPQ-229C120300UW01
Frequency Range	U-NII 5: 5925 MHz ~ 6425 MHz U-NII 6: 6425 MHz ~ 6525 MHz U-NII 7: 6525 MHz ~ 6875 MHz U-NII 8: 6875 MHz ~ 7125 MHz
Operation Frequency	UNII-5: 5955 MHz ~ 6415 MHz UNII-6: 6425 MHz ~ 6515 MHz UNII-7: 6535 MHz ~ 6875 MHz UNII-8: 6895 MHz ~ 7115 MHz
Modulation Technology	OFDMA
Transfer Rate	IEEE 802.11ax: up to 2402 Mbps IEEE 802.11be: up to 5764 Mbps
Maximum E.I.R.P. for UNII-5 - Non-Beamforming mode	IEEE 802.11ax (HE20): 13.15 dBm (0.0207 W) IEEE 802.11ax (HE40): 17.77 dBm (0.0599 W) IEEE 802.11ax (HE80): 20.07 dBm (0.1017 W) IEEE 802.11ax (HE160): 22.81 dBm (0.1909 W) IEEE 802.11be (EHT20): 13.65 dBm (0.0232 W) IEEE 802.11be (EHT40): 17.27 dBm (0.0534 W) IEEE 802.11be (EHT80): 20.72 dBm (0.1180 W) IEEE 802.11be (EHT160): 23.32 dBm (0.2150 W) IEEE 802.11be (EHT320): 26.12 dBm (0.4090 W)
Maximum E.I.R.P. for UNII-5 - Beamforming mode	IEEE 802.11ax (HE20): 15.73 dBm (0.0374 W) IEEE 802.11ax (HE40): 20.29 dBm (0.1069 W) IEEE 802.11ax (HE80): 22.54 dBm (0.1794 W) IEEE 802.11ax (HE160): 25.38 dBm (0.3451 W) IEEE 802.11be (EHT20): 16.22 dBm (0.0419 W) IEEE 802.11be (EHT40): 19.83 dBm (0.0962 W) IEEE 802.11be (EHT80): 23.22 dBm (0.2099 W) IEEE 802.11be (EHT160): 25.82 dBm (0.3819 W) IEEE 802.11be (EHT320): 28.67 dBm (0.7362 W)
Maximum E.I.R.P. for UNII-6 - Non-Beamforming mode	IEEE 802.11ax (HE20): 12.70 dBm (0.0185 W) IEEE 802.11ax (HE40): 16.56 dBm (0.0453 W) IEEE 802.11ax (HE80): 19.44 dBm (0.0878 W) IEEE 802.11ax (HE160): 22.36 dBm (0.1722 W) IEEE 802.11be (EHT20): 13.64 dBm (0.0231 W) IEEE 802.11be (EHT40): 16.98 dBm (0.0499 W) IEEE 802.11be (EHT80): 20.06 dBm (0.1014 W) IEEE 802.11be (EHT160): 22.83 dBm (0.1921 W) IEEE 802.11be (EHT320): 26.03 dBm (0.4005 W)

Maximum E.I.R.P. for UNII-6 - Beamforming mode	IEEE 802.11ax (HE20): 15.23 dBm (0.0333 W) IEEE 802.11ax (HE40): 19.16 dBm (0.0824 W) IEEE 802.11ax (HE80): 22.44 dBm (0.1754 W) IEEE 802.11ax (HE160): 24.91 dBm (0.3097 W) IEEE 802.11be (EHT20): 16.18 dBm (0.0415 W) IEEE 802.11be (EHT40): 19.51 dBm (0.0893 W) IEEE 802.11be (EHT80): 22.61 dBm (0.1824 W) IEEE 802.11be (EHT160): 25.33 dBm (0.3412 W) IEEE 802.11be (EHT320): 28.59 dBm (0.7228 W)
Maximum E.I.R.P. for UNII-7 - Non-Beamforming mode	IEEE 802.11ax (HE20): 13.20 dBm (0.0209 W) IEEE 802.11ax (HE40): 17.79 dBm (0.0601 W) IEEE 802.11ax (HE80): 19.90 dBm (0.0978 W) IEEE 802.11ax (HE160): 22.68 dBm (0.1852 W) IEEE 802.11be (EHT20): 14.35 dBm (0.0272 W) IEEE 802.11be (EHT40): 17.27 dBm (0.0533 W) IEEE 802.11be (EHT80): 20.51 dBm (0.1125 W) IEEE 802.11be (EHT160): 22.85 dBm (0.1926 W) IEEE 802.11be (EHT320): 26.09 dBm (0.4068 W)
Maximum E.I.R.P. for UNII-7 - Beamforming mode	IEEE 802.11ax (HE20): 15.77 dBm (0.0378 W) IEEE 802.11ax (HE40): 20.37 dBm (0.1089 W) IEEE 802.11ax (HE80): 22.90 dBm (0.1950 W) IEEE 802.11ax (HE160): 25.21 dBm (0.3319 W) IEEE 802.11be (EHT20): 16.82 dBm (0.0481 W) IEEE 802.11be (EHT40): 19.75 dBm (0.0944 W) IEEE 802.11be (EHT80): 23.51 dBm (0.2244 W) IEEE 802.11be (EHT160): 25.57 dBm (0.3606 W) IEEE 802.11be (EHT320): 28.63 dBm (0.7295 W)
Maximum E.I.R.P. for UNII-8 - Non-Beamforming mode	IEEE 802.11ax (HE20): 13.29 dBm (0.0213 W) IEEE 802.11ax (HE40): 17.21 dBm (0.0527 W) IEEE 802.11ax (HE80): 20.12 dBm (0.1027 W) IEEE 802.11ax (HE160): 22.74 dBm (0.1879 W) IEEE 802.11be (EHT20): 14.34 dBm (0.0271 W) IEEE 802.11be (EHT40): 17.05 dBm (0.0506 W) IEEE 802.11be (EHT80): 20.19 dBm (0.1045 W) IEEE 802.11be (EHT160): 22.81 dBm (0.1909 W) IEEE 802.11be (EHT320): 25.65 dBm (0.3675 W)
Maximum E.I.R.P. for UNII-8 - Beamforming mode	IEEE 802.11ax (HE20): 15.85 dBm (0.0385 W) IEEE 802.11ax (HE40): 19.80 dBm (0.0955 W) IEEE 802.11ax (HE80): 23.12 dBm (0.2051 W) IEEE 802.11ax (HE160): 25.24 dBm (0.3342 W) IEEE 802.11be (EHT20): 17.32 dBm (0.0540 W) IEEE 802.11be (EHT40): 19.55 dBm (0.0902 W) IEEE 802.11be (EHT80): 22.72 dBm (0.1871 W) IEEE 802.11be (EHT160): 25.34 dBm (0.3420 W) IEEE 802.11be (EHT320): 28.24 dBm (0.6668 W)
Operating Software	QSPR v5.14.00227.1
Test Model	T7
Sample Status	Engineering Sample
EUT Modification(s)	N/A

## NOTE:

- (1) The above EUT information is declared by manufacturer and for more detailed features description, please refers to the manufacturer's specifications or user's manual.

## (2) Channel List:

UNII-5							
IEEE 802.11ax (HE20) IEEE 802.11be (EHT20)		IEEE 802.11ax (HE40) IEEE 802.11be (EHT40)		IEEE 802.11ax (HE80) IEEE 802.11be (EHT80)		IEEE 802.11ax (HE160) IEEE 802.11be (EHT160)	
Channel	Frequency (MHz)	Channel	Frequency (MHz)	Channel	Frequency (MHz)	Channel	Frequency (MHz)
1	5955	3	5965	7	5985	15	6025
5	5975	11	6005	23	6065	47	6185
9	5995	19	6045	39	6145	79	6345
13	6015	27	6085	55	6225		
17	6035	35	6125	71	6305		
21	6055	43	6165	87	6385		
25	6075	51	6205				
29	6095	59	6245				
33	6115	67	6285				
37	6135	75	6325				
41	6155	83	6365				
45	6175	91	6405				
49	6195						
53	6215						
57	6235						
61	6255						
65	6275						
69	6295						
73	6315						
77	6335						
81	6355						
85	6375						
89	6395						
93	6415						



UNII-6							
IEEE 802.11ax (HE20) IEEE 802.11be (EHT20)		IEEE 802.11ax (HE40) IEEE 802.11be (EHT40)		IEEE 802.11ax (HE80) IEEE 802.11be (EHT80)		IEEE 802.11ax (HE160) IEEE 802.11be (EHT160)	
Channel	Frequency (MHz)	Channel	Frequency (MHz)	Channel	Frequency (MHz)	Channel	Frequency (MHz)
97	6435	99	6445	103	6465	111	6505
101	6455	107	6485				
105	6475						
109	6495						
113	6515						

UNII-7							
IEEE 802.11ax (HE20) IEEE 802.11be (EHT20)		IEEE 802.11ax (HE40) IEEE 802.11be (EHT40)		IEEE 802.11ax (HE80) IEEE 802.11be (EHT80)		IEEE 802.11ax (HE160) IEEE 802.11be (EHT160)	
Channel	Frequency (MHz)	Channel	Frequency (MHz)	Channel	Frequency (MHz)	Channel	Frequency (MHz)
117	6535	115	6525	119	6545	143	6665
121	6555	123	6565	135	6625	175	6825
125	6575	131	6605	151	6705		
129	6595	139	6645	167	6785		
133	6615	147	6685	183	6865		
137	6635	155	6725				
141	6655	163	6765				
145	6675	171	6805				
149	6695	179	6845				
153	6715						
157	6735						
161	6755						
165	6775						
169	6795						
173	6815						
177	6835						
181	6855						
185	6875						

UNII-8							
IEEE 802.11ax (HE20) IEEE 802.11be (EHT20)		IEEE 802.11ax (HE40) IEEE 802.11be (EHT40)		IEEE 802.11ax (HE80) IEEE 802.11be (EHT80)		IEEE 802.11ax (HE160) IEEE 802.11be (EHT160)	
Channel	Frequency (MHz)	Channel	Frequency (MHz)	Channel	Frequency (MHz)	Channel	Frequency (MHz)
189	6895	187	6885	199	6945	207	6985
193	6915	195	6925	215	7025		
197	6935	203	6965				
201	6955	211	7005				
205	6975	219	7045				
209	6995	227	7085				
213	7015						
217	7035						
221	7055						
225	7075						
229	7095						
233	7115						

IEEE 802.11be (EHT320)							
UNII-5		UNII-6		UNII-7		UNII-8	
Channel	Frequency (MHz)	Channel	Frequency (MHz)	Channel	Frequency (MHz)	Channel	Frequency (MHz)
31	6105	95	6425	127	6585	191	6905
63	6265			159	6745		

## (3) Table for Filed Antenna:

Ant.	Brand	Part number	Type	Connector	Frequency Range (MHz)	Gain (dBi)
1		SH23227IB65-1	PIFA	I-PEX	5950-7120	3.23
2		SH23227IB65-2	PIFA	I-PEX	5950-7120	3.61

Note:

 $CDD \text{ Directional Gain} = \text{Antenna Gain} + \text{Array Gain}, \text{Array Gain} = 0 \text{ dB for } N_{ANT} \leq 4;$ 
 $CDD \text{ Directional Gain} = 3.61 + 0 = 3.61$ 
 $\text{Beamforming Directional Gain} = \text{Antenna Gain} + 10 * \log(N_{ANT}/N_{SS}).$ 
 $\text{Beamforming Directional Gain} = 3.61 + 3 = 6.61$ 

- (4) The above Antenna information are derived from the antenna data sheet provided by manufacturer and for more detailed features description, please refer to the manufacturer's specifications, the laboratory shall not be held responsible.

## (5) Operating Mode and Antenna Configuration

TX Mode	Operating Mode	2TX
	IEEE 802.11ax (HE20)	V (Ant. 1 + Ant. 2)
	IEEE 802.11ax (HE40)	V (Ant. 1 + Ant. 2)
	IEEE 802.11ax (HE80)	V (Ant. 1 + Ant. 2)
	IEEE 802.11ax (HE160)	V (Ant. 1 + Ant. 2)
	IEEE 802.11be (EHT20)	V (Ant. 1 + Ant. 2)
	IEEE 802.11be (EHT40)	V (Ant. 1 + Ant. 2)
	IEEE 802.11be (EHT80)	V (Ant. 1 + Ant. 2)
	IEEE 802.11be (EHT160)	V (Ant. 1 + Ant. 2)
	IEEE 802.11be (EHT320)	V (Ant. 1 + Ant. 2)

**2.2 TEST MODES**

Test Items	Test mode	Channel	Note
AC power line conducted emissions	Normal/Idle	-	-
Undesirable emissions (below 1GHz)	IEEE 802.11ax (HE20)	233	-
Undesirable emissions (above 1GHz)	IEEE 802.11ax (HE20)	1/93, 97/113	Bandedge
	IEEE 802.11be (EHT20)	117/181, 185/233	
	IEEE 802.11ax (HE40)	3/91, 99/107	
	IEEE 802.11be (EHT40)	115/179, 187/227	
	IEEE 802.11ax (HE80)	7/87, 103/119	
	IEEE 802.11be (EHT80)	135/167, 183/215	
	IEEE 802.11ax (HE160)	15/79, 111	
	IEEE 802.11be (EHT160)	143, 207	
	IEEE 802.11be (EHT320)	31/63, 95 127/159, 191	Harmonic
	IEEE 802.11ax (HE20)	1/45/93 97/105/113	
	IEEE 802.11be (EHT20)	117/149/181 185/209/229/233	
	IEEE 802.11ax (HE40)	3/43/91, 99/107	
	IEEE 802.11be (EHT40)	115/147/179 187/227	
	IEEE 802.11ax (HE80)	7/39/87, 103/119	
IEEE 802.11be (EHT80)	135/167 183/199/215		
IEEE 802.11ax (HE160)	15/79, 111	-	
IEEE 802.11be (EHT160)	143, 207		
IEEE 802.11be (EHT320)	31/63, 95 127/159, 191		
Undesirable emissions (above 18GHz)	IEEE 802.11ax (HE20)	233	-
Maximum e.i.r.p. & Maximum transmitter channel bandwidth & Maximum power spectral density & In-band emission (Mask)	IEEE 802.11ax (HE20)	1/45/93 97/105/113	-
	IEEE 802.11be (EHT20)	117/149/181 185/209/229/233	
	IEEE 802.11ax (HE40)	3/43/91, 99/107	
	IEEE 802.11be (EHT40)	115/147/179 187/227	
	IEEE 802.11ax (HE80)	7/39/87, 103/119	
	IEEE 802.11be (EHT80)	135/167 183/199/215	
Contention-based protocol	IEEE 802.11ax (HE20)	37, 101 117, 197	-
	IEEE 802.11ax (HE160)	15, 111 143, 207	

**NOTE:**

- (1) For radiated emission band edge test, both Vertical and Horizontal are evaluated, but only the worst case (Vertical) is recorded.
- (2) All X, Y and Z axes are evaluated, but only the worst case (X axis) is recorded.
- (3) For IEEE 802.11ax modes, refer to TCB Workshop presentations on October 3, 2018, after evaluated, all testing are performed under fully loaded conditions (Full RU). In the test data, only the partially loaded conditions data are marked with tones.
- (4) The measurements for RF Output Power are tested, the Non Beamforming and Beamforming are recorded in the report. The worst case is Non Beamforming and only the worst case is documented for other test items.
- (5) For radiated emission above 18GHz test, only tested and recorded the worst case.
- (6) IEEE 802.11ax mode and IEEE 802.11be mode only supports full RU and nonsupports channel puncturing, so only the full RU is evaluated and measured inside report.



**2.3 TESTED CONFIGURATION DIAGRAM**

Equipment letters and Cable numbers refer to item numbers described in the tables of clause 2.4.

Undesirable emissions

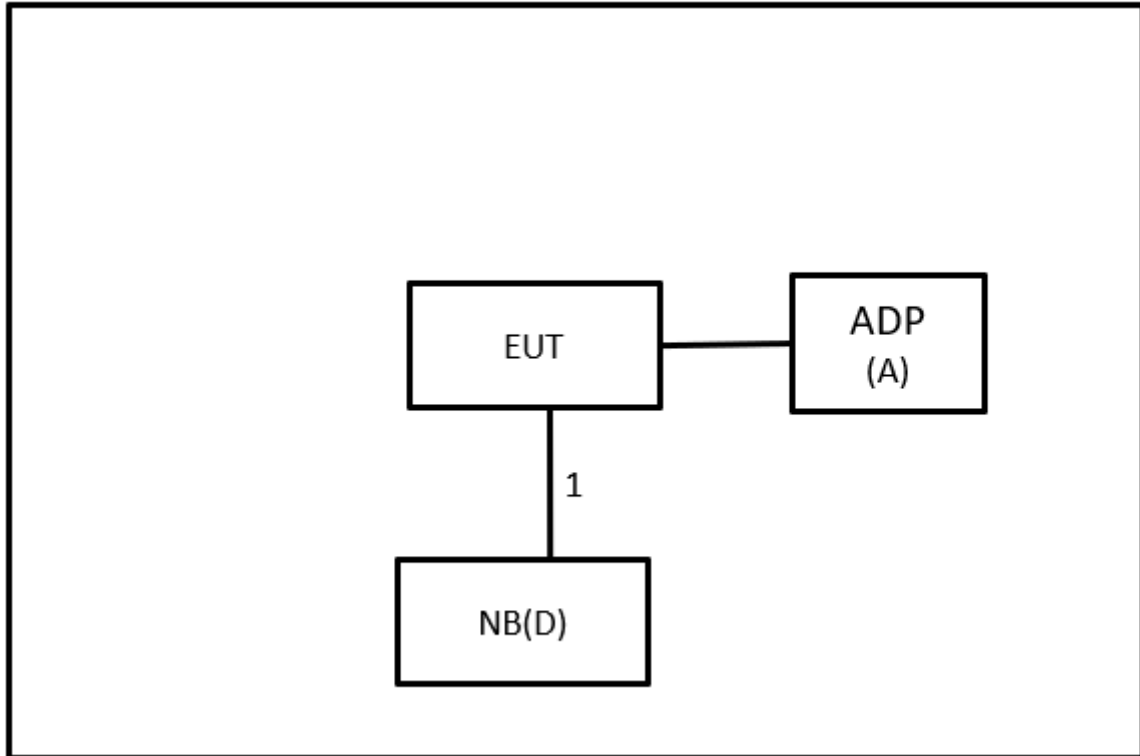

AC power line conducted emissions

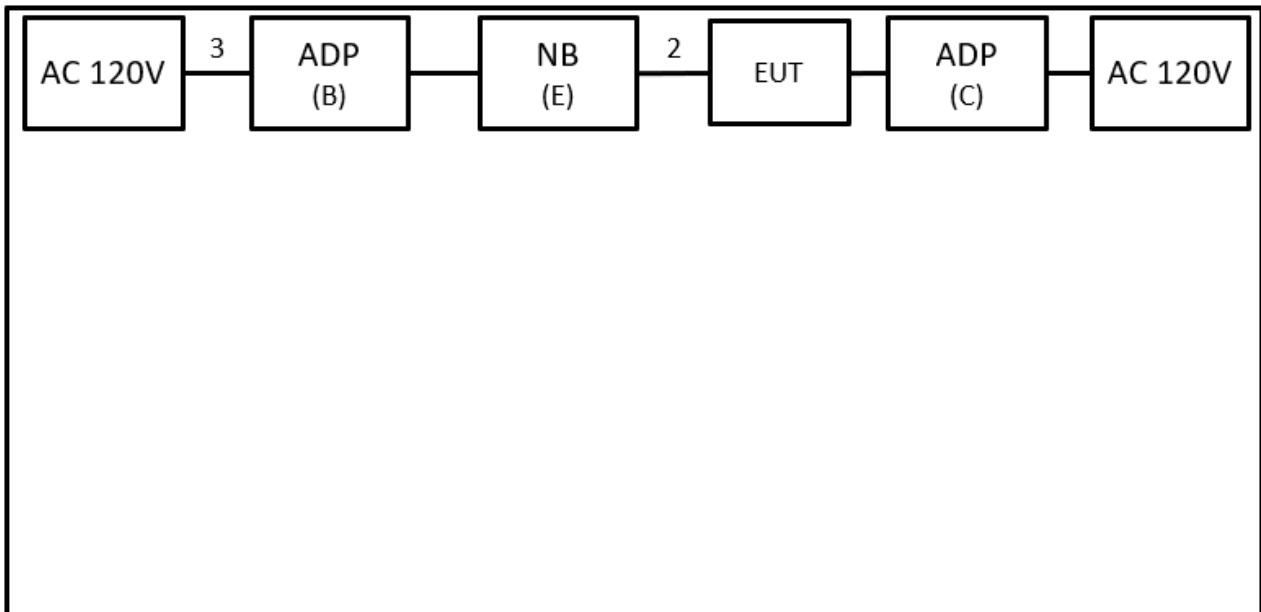

**2.4 SUPPORT UNITS**

Item	Equipment	Brand	Model No.	Series No.	Remarks
A	Adapter	N/A	TPQ-229C120300VW01	N/A	Supplied by test requester
B	Adapter	HP	HSTNN-CA40	N/A	Furnished by test lab.
C	Adapter	N/A	TPQ-229C120300UW01	N/A	Supplied by test requester
D	NB	HP	TPN-I119	N/A	Furnished by test lab.
E	NB	HP	240 G5	N/A	Furnished by test lab.

Item	Shielded	Ferrite Core	Length	Cable Type	Remarks
1	No	No	1m	RJ45 Cable	Furnished by test lab.
2	No	No	0.5m	RJ45 Cable	Furnished by test lab.
3	No	No	1m	Power Cord	Furnished by test lab.

### 3 MAXIMUM E.I.R.P. TEST

#### 3.1 LIMITS

According to 15.407(a)(4)(5)(6)(7)(8) the limits are as follows:

Equipment Category	Band	Maximum e.i.r.p. Limit
Standard power access point* Fixed client*	U-NII 5 (5.925-6.425 GHz)	36 dBm
	U-NII 7 (6.525-6.875 GHz)	
Indoor access point Subordinate device	U-NII 5 (5.925-6.425 GHz)	30 dBm
	U-NII 6 (6.425-6.525 GHz)	
	U-NII 7 (6.525-6.875 GHz)	
	U-NII 8 (6.875-7.125 GHz)	
Standard power access point client devices	U-NII 5 (5.925-6.425 GHz)	30 dBm and the device must limit its power to no more than 6 dB below its associated standard power access point's authorized transmit power
	U-NII 6 (6.425-6.525 GHz)	
	U-NII 7 (6.525-6.875 GHz)	
	U-NII 8 (6.875-7.125 GHz)	
Indoor access point client devices	U-NII 5 (5.925-6.425 GHz)	24 dBm
	U-NII 6 (6.425-6.525 GHz)	
	U-NII 7 (6.525-6.875 GHz)	
	U-NII 8 (6.875-7.125 GHz)	

\* For outdoor devices, the maximum e.i.r.p. at any elevation angle above 30 degrees as measured from the horizon must not exceed 125 mW (21 dBm).

According to 15.407(a)(11):

The maximum conducted output power must be measured over any interval of continuous transmission using instrumentation calibrated in terms of an rms-equivalent voltage.

#### 3.2 TEST PROCEDURE

Referring to FCC KDB 987594 D02, clause E. and FCC KDB 789033 D02, clause E. 3 Measurement using a Power Meter (PM):

- a. The maximum peak conducted output power was performed in accordance with method of clause E. 3. a) Method PM (Measurement using an RF average power meter):
  - (i) Measurements may be performed using a wideband RF power meter with a thermocouple detector or equivalent if all of the following conditions are satisfied:
    - The EUT is configured to transmit continuously or to transmit with a constant duty cycle.
    - At all times when the EUT is transmitting, it must be transmitting at its maximum power control level.
    - The integration period of the power meter exceeds the repetition period of the transmitted signal by at least a factor of five.
  - (ii) If the transmitter does not transmit continuously, measure the duty cycle,  $x$ , of the transmitter output signal.
  - (iii) Measure the average power of the transmitter. This measurement is an average over both the on and off periods of the transmitter.
  - (iv) Adjust the measurement in dBm by adding  $10 \log (1/x)$  where  $x$  is the duty cycle (e.g.,  $10 \log (1/0.25)$  if the duty cycle is 25%).
- b. The maximum peak conducted output power was performed in accordance with method of clause E. 3. b) Method PM-G (Measurement using a gated RF average power meter):
 Measurements may be performed using a wideband gated RF power meter provided that the gate parameters are adjusted such that the power is measured only when the EUT is transmitting at its maximum power control level. Since the measurement is made only during the ON time of the transmitter, no duty cycle correction factor is required.

Referring to FCC KDB 987594 D02, clause H. Measurement of emission at elevation angles higher than 30° from horizon:

Note: Elevation angle is defined as 0° is horizontal and 90° is straight-up.

**For fixed infrastructure, not electrically or mechanically steerable beam antenna**

- a. If elevation plane radiation pattern is available:
- (i) Determine the device intended mounting elevation angle and define 0° reference angle on the elevation plane radiation pattern.
  - (ii) Indicate any radiation pattern between 30° and 90° which has the highest gain.
  - (iii) Calculate the EIRP based on this highest gain and conducted output power.
  - (iv) Compare to the 125 mW limit to establish compliance.
  - (v) Include the elevation pattern data in the application filing with the test report to show how the calculations are made.

Note: For MIMO devices, take the maximum gain of each antenna and apply the guidance in KDB Publication 662911 for calculating the overall gain including directional gain for the maximum EIRP calculation.

- b. If the elevation plane radiation pattern is not available, but the antenna type (such as dipole omnidirectional, Yagi, parabolic, or sector antenna) has a symmetrical elevation plane pattern referenced at the main beam and all lobes on the main beam elevation plane have highest gains, then the following measurement method is acceptable to determine compliance:
- (i) Determine the device's intended mounting elevation angle referenced to the horizon.
  - (ii) Rotate the EUT antenna by 90° around the main beam axis in a horizontal position to transform the measurement in elevation angle into an azimuth angle and define a 0° reference angle based on the device's intended mounting elevation angle.
  - (iii) Move the test antenna along the horizontal arc, or rotate the turntable with the EUT antenna placed at the center, between 30° and 90° relative to the 0° reference angle, and then continuing down from 90° to 30° on the other side of the pattern, while maintaining the test antenna pointing with constant distance to the EUT antenna. Search for the spot which has the highest measured emission. Both horizontal and vertical polarization shall be investigated to determine the maximum radiated emission level.

Note: Moving the test antenna along the horizontal arc, or rotating the turntable, shall be performed in an angular step size as small as possible, but not larger than 3°.

- (iv) Calculate the EIRP based on the highest measured emission. Compare to the limit of 125 mW to determine compliance.
- (v) The antenna pattern measurements must be included in the filing.

**For All Other Antenna Types**

For all other antenna types (such as patch antennas, array antennas, antennas with irregular radiator shapes, etc.) which have any combination of following characteristics:

- Asymmetrical, complex radiation patterns
- 2-D or 3-D steerable beam
- Portable/mobile, not fixed infrastructure device

Provide the following information in the report:

- a. Describe what type of antenna is used.
- b. Determine by calculation, measurement or simulation, all radiation lobes/beams, which have EIRP higher than 125 mW within a 3-dB elevation beamwidth.
- c. Provide an explanation of how these antenna beams are controlled to be kept below the 30° elevation angle. The explanation should include device installation instructions, mechanical control, electro-mechanical control or software algorithms, if the beams are electrically controlled by software.

**3.3 DEVIATION FROM TEST STANDARD**

No deviation.

**3.4 TEST SETUP****3.5 EUT OPERATING CONDITIONS**

The EUT was programmed to be in continuously transmitting mode.

**3.6 TEST RESULT**

Please refer to the APPENDIX A.

## 4 MAXIMUM TRANSMITTER CHANNEL BANDWIDTH TEST

### 4.1 LIMITS

According to 15.407(a)(10):

The maximum transmitter channel bandwidth for U-NII devices in the 5.925-7.125 GHz band is 320 megahertz.

### 4.2 TEST PROCEDURE

#### For Emission Bandwidth (EBW):

Referring to FCC KDB 987594 D02, clause C. and FCC KDB 789033 D02, clause C. 1. Emission Bandwidth (EBW):

- a) Set RBW = approximately 1% of the emission bandwidth.
- b) Set the VBW > RBW.
- c) Detector = Peak.
- d) Trace mode = max hold.
- e) Measure the maximum width of the emission that is 26 dB down from the maximum of the emission. Compare this with the RBW setting of the analyzer. Readjust RBW and repeat measurement as needed until the RBW/EBW ratio is approximately 1%.

#### For 99% Occupied Bandwidth:

Referring to FCC KDB 987594 D02, clause D. and FCC KDB 789033 D02, clause D. 99% Occupied Bandwidth:

The 99% occupied bandwidth is the frequency bandwidth such that, below its lower and above its upper frequency limits, the mean powers are each equal to 0.5% of the total mean power of the given emission. Measurement of the 99% occupied bandwidth is required only as a condition for using the optional band-edge measurement techniques. Measurements of 99% occupied bandwidth may also optionally be used in lieu of the EBW to define the minimum frequency range over which the spectrum is integrated when measuring maximum conducted output power. However, the EBW must be measured to determine bandwidth dependent limits on maximum conducted output power in accordance with Section 15.407(a).

The following procedure shall be used for measuring (99%) power bandwidth:

1. Set center frequency to the nominal EUT channel center frequency.
2. Set span = 1.5 times to 5.0 times the OBW.
3. Set RBW = 1% to 5% of the OBW
4. Set  $VBW \geq 3 \text{ RBW}$
5. Video averaging is not permitted. Where practical, a sample detection and single sweep mode shall be used. Otherwise, peak detection and max hold mode (until the trace stabilizes) shall be used.
6. Use the 99% power bandwidth function of the instrument (if available).
7. If the instrument does not have a 99% power bandwidth function, the trace data points are recovered and directly summed in power units. The recovered amplitude data points, beginning at the lowest frequency, are placed in a running sum until 0.5% of the total is reached; that frequency is recorded as the lower frequency. The process is repeated until 99.5% of the total is reached; that frequency is recorded as the upper frequency. The 99% occupied bandwidth is the difference between these two frequencies.

**4.3 DEVIATION FROM TEST STANDARD**

No deviation.

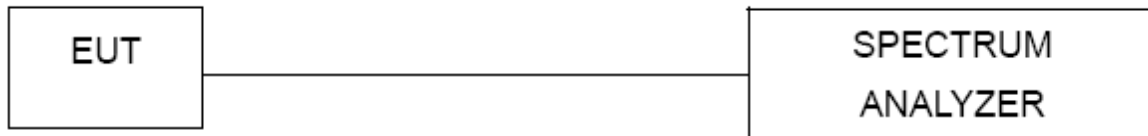
**4.4 TEST SETUP****4.5 EUT OPERATING CONDITIONS**

The EUT was programmed to be in continuously transmitting mode.

**4.6 TEST RESULT**

Please refer to the APPENDIX B.

## 5 MAXIMUM POWER SPECTRAL DENSITY TEST

### 5.1 LIMITS

According to 15.407(a)(4)(5)(6)(7)(8) the limits are as follows:

Equipment Category	Band	Maximum Power Spectral Density (e.i.r.p.) Limit
Standard power access point Fixed client	U-NII 5 (5.925-6.425 GHz)	23 dBm/MHz
	U-NII 7 (6.525-6.875 GHz)	
Indoor access point Subordinate device	U-NII 5 (5.925-6.425 GHz)	5 dBm/MHz
	U-NII 6 (6.425-6.525 GHz)	
	U-NII 7 (6.525-6.875 GHz)	
	U-NII 8 (6.875-7.125 GHz)	
Standard power access point client devices	U-NII 5 (5.925-6.425 GHz)	17 dBm/MHz
	U-NII 6 (6.425-6.525 GHz)	
	U-NII 7 (6.525-6.875 GHz)	
	U-NII 8 (6.875-7.125 GHz)	
Indoor access point client devices	U-NII 5 (5.925-6.425 GHz)	-1 dBm/MHz
	U-NII 6 (6.425-6.525 GHz)	
	U-NII 7 (6.525-6.875 GHz)	
	U-NII 8 (6.875-7.125 GHz)	

### 5.2 TEST PROCEDURE

Referring to FCC KDB 987594 D02, clause F. and FCC KDB 789033 D02, clause F. Maximum Power Spectral Density (PSD):

Method SA-1 is used.

- a. Set Attenuation = auto.
- b. Span Frequency = Encompass the entire emissions bandwidth (EBW) of the signal.
- c. Set RBW = 1 MHz.
- d. Set VBW > 3 MHz.
- e. Detector = RMS.
- f. Trace mode = max hold.
- g. Sweep time = auto.
- h. Record the maximum value.
- i. Record the maximum value and add  $10 \log(1/\text{duty cycle})$ .
- j. Record the maximum value and add 1 dB.



**5.3 DEVIATION FROM TEST STANDARD**

No deviation.

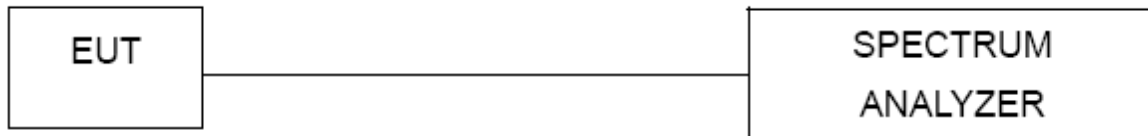
**5.4 TEST SETUP****5.5 EUT OPERATING CONDITIONS**

The EUT was programmed to be in continuously transmitting mode.

**5.6 TEST RESULT**

Please refer to the APPENDIX C.

## 6 UNDESIRABLE EMISSIONS TEST

### 6.1 LIMITS

According to 15.407(b)(6) the limits are as follows:

For transmitters operating within the 5.925-7.125 GHz band: Any emissions outside of the 5.925-7.125 GHz band must not exceed an e.i.r.p. of -27 dBm/MHz.

According to FCC KDB 987594 D02, clause G. Unwanted Emission Measurement:

Use guidance in KDB 789033 for measurements below 1000 MHz and above 1000 MHz. Unwanted emissions outside of restricted bands are measured with a RMS detector. In addition, 15.35(b) applies where the peak emissions must be limited to no more than 20 dB above the average limit

Item	Maximum e.i.r.p. Limit	Maximum field strength Limit @ 3m
Any emissions outside of the 5.925-7.125 GHz band	Peak: -7 dBm/MHz	88.2 dBuV/m
	Average: -27 dBm/MHz	68.2 dBuV/m

Unwanted emissions below 1 GHz must comply with the general field strength limits set forth in § 15.209.

Frequency (MHz)	Field Strength (microvolts/meter)	Measurement Distance (meters)
0.009~0.490	2400/F(kHz)	300
0.490~1.705	24000/F(kHz)	30
1.705~30.0	30	30
30~88	100	3
88~216	150	3
216~960	200	3
960~1000	500	3

According to 15.407(b)(9) the limits are as follows:

Unwanted emissions below 1 GHz must comply with the general field strength limits set forth in § 15.209.

Frequency (MHz)	Field Strength (microvolts/meter)	Measurement Distance (meters)
0.009~0.490	2400/F(kHz)	300
0.490~1.705	24000/F(kHz)	30
1.705~30.0	30	30
30~88	100	3
88~216	150	3
216~960	200	3
960~1000	500	3

**NOTE:**

- (1) e.i.r.p. Limit (dBuV/m at 3m) = Power Limit(dBm) + 95.2. (Referring to FCC KDB 987594 D02, clause G.2.d)(iii))
- (2) Emission level (dBuV/m) = 20log Emission level (uV/m).  
3 m Emission level = 10 m Emission level + 20log(10 m/3 m).

(3) The test result calculated as following:

Measurement Value = Reading Level + Correct Factor

Correct Factor = Antenna Factor + Cable Loss - Amplifier Gain (if use)

Margin Level = Measurement Value - Limit Value

Calculation example:

Reading Level (dB $\mu$ V)		Correct Factor (dB/m)		Measurement Value (dB $\mu$ V/m)
19.11	+	2.11	=	21.22

Measurement Value (dB $\mu$ V/m)		Limit Value (dB $\mu$ V/m)		Margin Level (dB)
21.22	-	68.2	=	-46.98

Spectrum Parameter	Setting
Attenuation	Auto
Start Frequency	1000 MHz
Stop Frequency	10th carrier harmonic
RBW / VBW (Emission in restricted band)	1MHz / 3MHz for Peak, 1MHz / 1/T for Average

Spectrum Parameter	Setting
Attenuation	Auto
Start ~ Stop Frequency	9KHz~90KHz for PK/AVG detector
Start ~ Stop Frequency	90KHz~110KHz for QP detector
Start ~ Stop Frequency	110KHz~490KHz for PK/AVG detector
Start ~ Stop Frequency	490KHz~30MHz for QP detector
Start ~ Stop Frequency	30MHz~1000MHz for QP detector

## 6.2 TEST PROCEDURE

Referring to FCC KDB 987594 D02, clause G. and FCC KDB 789033 D02, clause G. Unwanted Emission Measurement:

For measurements below 30 MHz:

- The EUT was placed on the top of a rotating table 0.8 meters above the ground at a 3 meter chamber room. The table was rotated 360 degrees to determine the position of the highest radiation.
- The EUT was set 3 meters away from the interference-receiving antenna, which was mounted on the top of a variable-height antenna tower.
- Parallel, perpendicular, and ground-parallel orientations of the antenna are set to make the measurement.
- For each suspected emission, the EUT was arranged to its worst case and the rotatable table was turned from 0 degrees to 360 degrees to find the maximum reading.
- The test-receiver system was set to Quasi-Peak Detect Function and Specified Bandwidth with Maximum Hold Mode.

For measurements 30 MHz to 40 GHz:

- The measuring distance of 3 m shall be used for measurements. The EUT was placed on the top of a rotating table 0.8 meter above the ground at a 3 meter semi-anechoic chamber. The table was rotated 360 degrees to determine the position of the highest radiation. (between 30 MHz to 1 GHz)
- The measuring distance of 3 m shall be used for measurements. The EUT was placed on the top of a rotating table 1.5 meter above the ground at a 3 meter semi-anechoic chamber. The table was rotated 360 degrees to determine the position of the highest radiation. (between 1 GHz to 40 GHz)
- The height of the equipment or of the substitution antenna shall be 0.8 m or 1.5 m, the height of the test antenna shall vary between 1 m to 4 m. Both horizontal and vertical polarizations of the antenna are set to make the measurement.
- For each suspected emission, the EUT was arranged to its worst case and then the antenna was tuned to heights find the maximum reading (used Bore sight function).

- e. The receiver system was set to peak and average detect function and specified bandwidth with maximum hold mode when the test frequency is above 1GHz.
- f. The initial step in collecting radiated emission data is a receiver peak detector mode pre-scanning the measurement frequency range. Significant peaks are then marked and then Quasi Peak detector mode re-measured.
- g. All readings are Peak unless otherwise stated QP in column of Note. Peak denotes that the Peak reading compliance with the QP Limits and then QP Mode measurement didn't perform. (between 30 MHz to 1 GHz)
- h. All readings are Peak Mode value unless otherwise stated AVG in column of Note. If the Peak Mode Measured value compliance with the Peak Limits and lower than AVG Limits, the EUT shall be deemed to meet both Peak & AVG Limits and then only Peak Mode was measured, but AVG Mode didn't perform. (between 30 MHz to 1 GHz)

### 6.3 DEVIATION FROM TEST STANDARD

No deviation.

### 6.4 TEST SETUP

#### 9 kHz to 30 MHz

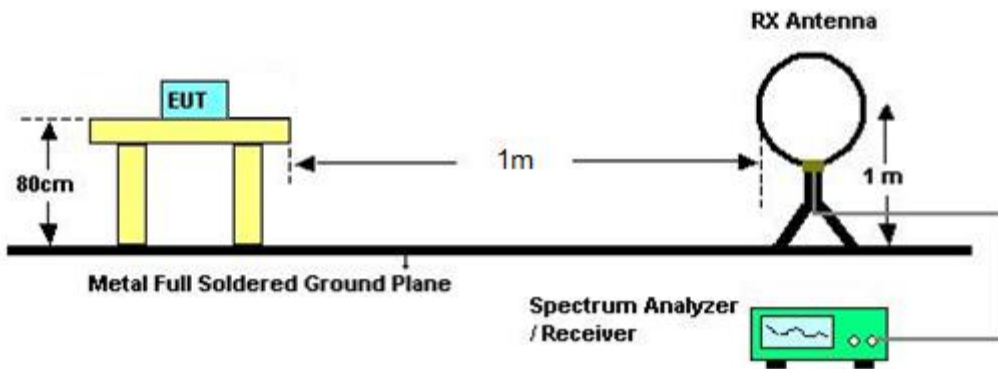

#### 30 MHz to 1 GHz

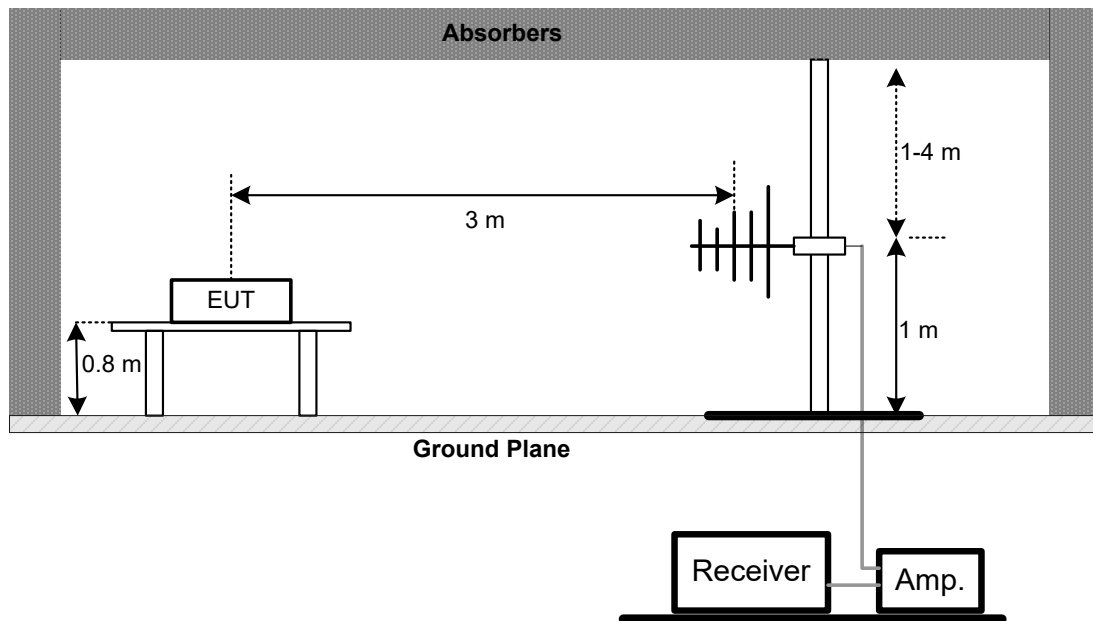

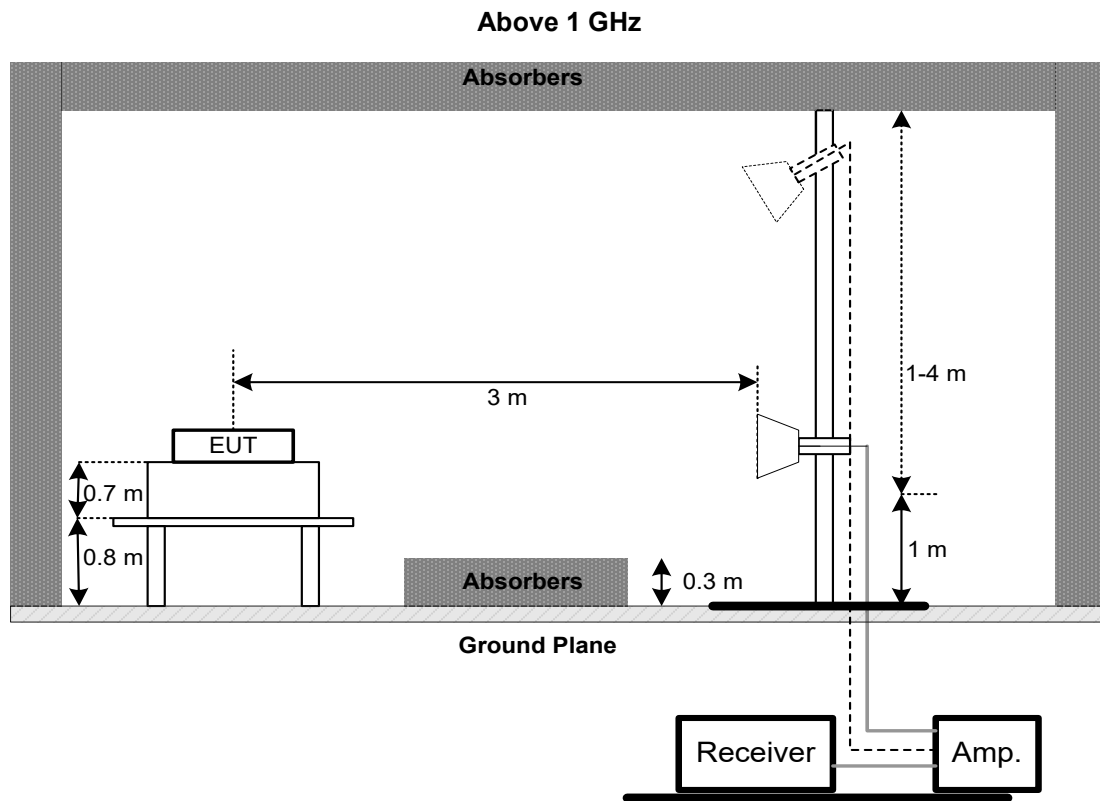

## 6.5 EUT OPERATING CONDITIONS

The EUT was programmed to be in continuously transmitting mode.

NOTE:

- (1) Distance extrapolation factor =  $40 \log (\text{specific distance} / \text{test distance})$  (dB).
- (2) Limit line = specific limits (dBuV) + distance extrapolation factor.

## 6.6 TEST RESULT – 9kHz TO 30 MHz

Please refer to the APPENDIX D.

## 6.7 TEST RESULT – 30 MHz TO 1 GHz

Please refer to the APPENDIX E.

## 6.8 TEST RESULT – ABOVE 1 GHz

Please refer to the APPENDIX F.

## 7 IN-BAND EMISSION (MASK) TEST

### 7.1 LIMITS

According to 15.407(b)(7) the limits are as follows:

Item	Test Frequency Range	Power spectral density suppressed Limit
In-Band Emissions (Mask)	at 1 MHz outside of channel edge	20 dB
	at one channel bandwidth from the channel center	28 dB
	at one- and one-half times the channel bandwidth away from channel center	40 dB
	Emissions removed from the channel center by more than one- and one-half times the channel bandwidth	40 dB

At frequencies between one megahertz outside an unlicensed device's channel edge and one channel bandwidth from the center of the channel, the limits must be linearly interpolated between 20 dB and 28 dB suppression, and at frequencies between one and one- and one-half times an unlicensed device's channel bandwidth, the limits must be linearly interpolated between 28 dB and 40 dB suppression.

### 7.2 TEST PROCEDURE

Referring to FCC KDB 987594 D02, clause J. In-Band Emissions:

- a. Connect output of the antenna port to a spectrum analyzer or EMI receiver, with appropriate attenuation, as to not damage the instrumentation.
- b. Set the reference level of the measuring equipment in accordance with procedure 4.1.5.2 of ANSI C63.10-2013.
- c. Measure the 26 dB EBW using the test procedure 12.4.1 of ANSI C63.10-2013. (This will be used to determine the channel edge.)
- d. Measure the power spectral density (which will be used for emissions mask reference) using the following procedure:
  - a) Set the span to encompass the entire 26 dB EBW of the signal.
  - b) Set RBW = same RBW used for 26 dB EBW measurement.
  - c) Set VBW  $\geq 3 \times$  RBW
  - d) Number of points in sweep  $\geq [2 \times \text{span} / \text{RBW}]$ .
  - e) Sweep time = auto.
  - f) Detector = RMS (i.e., power averaging)
  - g) Trace average at least 100 traces in power averaging (rms) mode.
  - h) Use the peak search function on the instrument to find the peak of the spectrum.
- e. For the purposes of developing the emission mask, the channel bandwidth is defined as the 26 dB EBW.
- f. Using the measuring equipment limit line function, develop the emissions mask based on the following requirements. The emissions power spectral density must be reduced below the peak power spectral density (in dB) as follows:
  - g. Suppressed by 20 dB at 1 MHz outside of the channel edge. (The channel edge is defined as the 26-dB point on either side of the carrier center frequency.)
  - h. Suppressed by 28 dB at one channel bandwidth from the channel center.
  - i. Suppressed by 40 dB at one- and one-half times the channel bandwidth from the channel center.
- j. Adjust the span to encompass the entire mask as necessary.
- k. Clear trace.
- l. Trace average at least 100 traces in power averaging (rms) mode.
- m. Adjust the reference level as necessary so that the crest of the channel touches the top of the emission mask.

**7.3 DEVIATION FROM TEST STANDARD**

No deviation.

**7.4 TEST SETUP****7.5 EUT OPERATING CONDITIONS**

The EUT was programmed to be in continuously transmitting mode.

**7.6 TEST RESULT**

Please refer to the APPENDIX G.

## 8 AC POWER LINE CONDUCTED EMISSIONS TEST

### 8.1 LIMITS

According to 15.407(b)(9) the limits are as follows:

Frequency (MHz)	Limit (dB $\mu$ V)	
	Quasi-peak	Average
0.15 - 0.5	66 - 56 *	56 - 46 *
0.50 - 5.0	56	46
5.0 - 30.0	60	50

**NOTE:**

- (1) The tighter limit applies at the band edges.
- (2) The limit of " \* " marked band means the limitation decreases linearly with the logarithm of the frequency in the range.
- (3) The test result calculated as following:  
 Measurement Value = Reading Level + Correct Factor  
 Correct Factor = Insertion Loss + Cable Loss + Attenuator Factor (if use)  
 Margin Level = Measurement Value – Limit Value  
 Calculation example:

Reading Level (dB $\mu$ V)		Correct Factor (dB)		Measurement Value (dB $\mu$ V)
38.22	+	3.45	=	41.67

Measurement Value (dB $\mu$ V)		Limit Value (dB $\mu$ V)		Margin Level (dB)
41.67	-	60	=	-18.33

The following table is the setting of the receiver.

Receiver Parameter	Setting
Attenuation	10 dB
Start Frequency	0.15 MHz
Stop Frequency	30 MHz
IF Bandwidth	9 KHz

### 8.2 TEST PROCEDURE

- a. The EUT was placed 0.8 m above the horizontal ground plane with the EUT being connected to the power mains through a line impedance stabilization network (LISN).  
 All other support equipment were powered from an additional LISN(s).  
 The LISN provides 50 Ohm/50uH of impedance for the measuring instrument.
- b. Interconnecting cables that hang closer than 40 cm to the ground plane shall be folded back and forth in the center forming a bundle to keep the cable above 40 cm.
- c. Excess I/O cables that are not connected to a peripheral shall be bundled in the center.  
 The end of the cable will be terminated, using the correct terminating impedance.  
 The overall length shall not exceed 1 m.
- d. The LISN is spaced at least 80 cm from the nearest part of the EUT chassis.
- e. For the actual test configuration, please refer to the related Item – EUT TEST PHOTOS.

**NOTE:**

- (1) In the results, each reading is marked as Peak, QP or AVG per the detector used.  
 BW=9 kHz (6 dB Bandwidth)
- (2) All readings are Peak unless otherwise stated QP or AVG in column of Note. Both the QP and the AVG readings must be less than the limit for compliance.



### 8.3 DEVIATION FROM TEST STANDARD

No deviation.

### 8.4 TEST SETUP

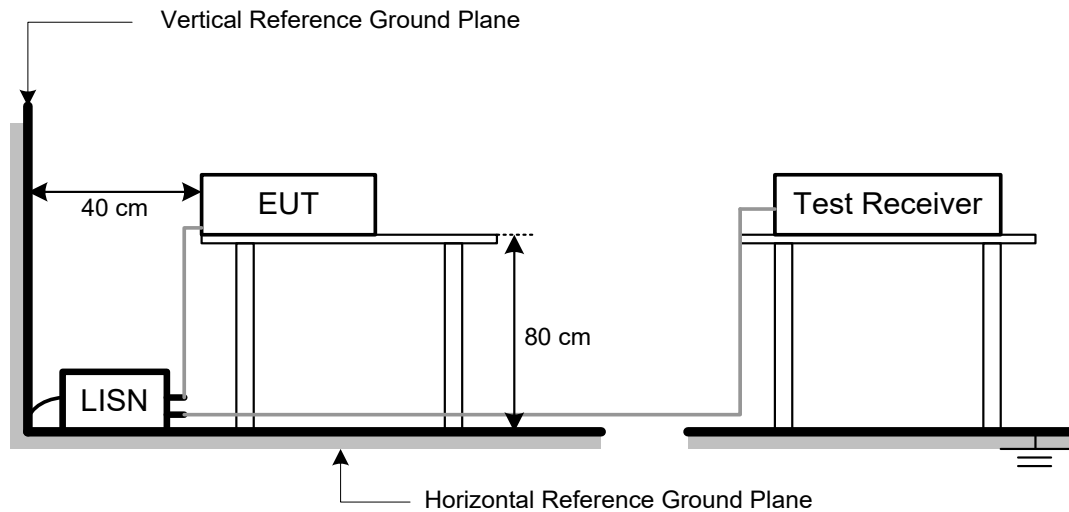

### 8.5 EUT OPERATING CONDITIONS

The EUT was configured for testing in a typical fashion (as a customer would normally use it). The EUT has been programmed to continuously transmit during test. This operating condition was tested and used to collect the included data.

The EUT was programmed to be in continuously transmitting/TX mode.

### 8.6 TEST RESULT

Please refer to the APPENDIX H.

## 9 CONTENTION-BASED PROTOCOL TEST

### 9.1 LIMITS

According to 15.407(d)(6) the limits are as follows:

Indoor access points, subordinate devices and client devices operating in the 5.925-7.125 GHz band must employ a contention-based protocol.

According to FCC KDB 987594 D02, clause I. Contention Based Protocol:

Indoor access points, subordinate devices and client devices operating in the 5.925-7.125 GHz band (herein referred to as unlicensed devices) are required to use technologies that include a contention-based protocol to avoid co-channel interference with incumbent devices sharing the band. To ensure incumbent co-channel operations are detected in a technology-agnostic manner, unlicensed devices are required to detect co-channel radio frequency energy (energy detect) and avoid simultaneous transmission.

Unlicensed low-power indoor devices must detect co-channel radio frequency power that is at least -62 dBm or lower. Upon detection of energy in the band, unlicensed low power indoor devices must vacate the channel (in which incumbent signal is transmitted) and stay off the incumbent channel as long as detected radio frequency power is equal to or greater than the threshold (-62 dBm)<sup>1</sup>. The -62 dBm (or lower) threshold is referenced to a 0 dBi antenna gain.

To ensure incumbent operations are reliably detected in the band, low power indoor devices must detect RF energy throughout their intended operating channel. For example, an 802.11 device that plans to transmit a 40 MHz- wide signal (on a primary 20 MHz channel and a secondary 20 MHz channel) must detect energy throughout the entire 40 MHz channel. Additionally, low-power indoor devices must detect co-channel energy with 90% or greater certainty.

### 9.2 TEST PROCEDURE

Referring to FCC KDB 987594 D02, clause I. Contention Based Protocol:

**Table 1. Criteria to determine number of times detection threshold test may be performed**

<b>If</b>	<b>Number of Tests</b>	<b>Placement of Incumbent Transmission</b>
$BW_{EUT} \leq BW_{Inc}$	Once	Tune incumbent and EUT transmissions ( $f_{c1} = f_{c2}$ )
$BW_{Inc} < BW_{EUT} \leq 2BW_{Inc}$	Once	Incumbent transmission is contained within $BW_{EUT}$
$2BW_{Inc} < BW_{EUT} \leq 4BW_{Inc}$	Twice. Incumbent transmission is contained within $BW_{EUT}$	Incumbent transmission is located as closely as possible to the lower edge and upper edge, respectively, of the EUT channel
$BW_{EUT} > 4BW_{Inc}$	Three times	Incumbent transmission is located as closely as possible to the lower edge of the EUT channel, in the middle of EUT channel, and as closely as possible to the upper edge of the EUT channel

**For Conducted measurement:**

- a. Configure the EUT to transmit with a constant duty cycle.
- b. Set the operating parameters of the EUT including power level, operating frequency, modulation and bandwidth.
- c. Set the signal analyzer center frequency to the nominal EUT channel center frequency. The span range of the signal analyzer shall be between two times and five times the OBW of the EUT. Connect the output port of the EUT to the signal analyzer 2. Ensure that the attenuator 2 provides enough attenuation to not overload the signal analyzer 2 receiver.
- d. Monitoring the signal analyzer 2, verify the EUT is operating and transmitting with the parameters set at step b.
- e. Using an AWGN signal source, generate (but do not transmit, i.e., RF OFF) a 10 MHz-wide AWGN signal. Use Table 1 to determine the center frequency of the 10 MHz AWGN signal relative to the EUT's channel bandwidth and center frequency.
- f. Set the AWGN signal power to an extremely low level (more than 20 dB below the -62 dBm threshold). Connect the AWGN signal source, via a 3-dB splitter, to the signal analyzer 1 and the EUT.
- g. Transmit the AWGN signal (RF ON) and verify its characteristics on the signal analyzer 1.
- h. Monitor the signal analyzer 2 to verify if the AWGN signal has been detected and the EUT has ceased transmission. If the EUT continues to transmit, then incrementally increase the AWGN signal power level until the EUT stops transmitting.
- i. (Including all losses in the RF paths) Determine and record the AWGN signal power level (at the EUT's antenna port) at which the EUT ceased transmission. Repeat the procedure at least 10 times to verify the EUT can detect an AWGN signal with 90% (or better) level of certainty.
- j. Refer to Table 1 to determine number of times the detection threshold testing needs to be repeated. If testing is required more than once, then go back to step e, choose a different center frequency for the AWGN signal and repeat the process.

**For Radiated measurement:**

- a. Using the AWGN signal source, generate (but do not transmit, i.e., RF OFF) a 10 MHz-wide AWGN signal. Use Table 1 to determine the center frequency of the 10 MHz AWGN signal relative to the EUT's channel bandwidth and center frequency.
- b. Connect the AWGN signal source to antenna 1 and transmit the signal (RF ON).
- c. Using signal analyzer 1 and antenna 2, measure the AWGN signal power level. Align antenna 2 and antenna 1 to maximize emission.
- d. Using equation  $P_2 = P_{\text{meas}} + L - G_2$ , correct the measured power  $P_{\text{meas}}$  by the gain of antenna 2,  $G_2$  and all cable losses and attenuations  $L$  to obtain the AWGN signal power level at antenna 2,  $P_2$ .
- e. Set the corrected power  $P_2$  to an extremely low level (more than 20 dB below the -62 dBm threshold).
- f. Place the EUT exactly where antenna 2 was. Configure the EUT to transmit a constant duty cycle.
- g. Set the operating parameters of the EUT including power level, operating frequency, modulation and bandwidth.
- h. Set the signal analyzer 1 center frequency to the nominal EUT channel center frequency. The span range of the signal analyzer shall be between two times and five times the OBW of EUT.
- i. Monitor the signal analyzer 1 to verify if AWGN signal has been detected and EUT has ceased transmission. If the EUT continues to transmit, then incrementally increase the AWGN signal power level until the EUT stops transmitting.
- j. Determine and record the AWGN signal power level at which the EUT ceased transmission. Repeat the procedure at least 10 times to verify the EUT can detect the AWGN signal with 90% (or better) level of certainty.
- k. Refer to Table 1 to determine number of times the detection threshold testing needs to be repeated. If testing is required more than once, then go back to step a, choose a different center frequency for the AWGN signal and repeat the process.

**9.3 DEVIATION FROM TEST STANDARD**

No deviation.

## 9.4 TEST SETUP

For Conducted measurement:

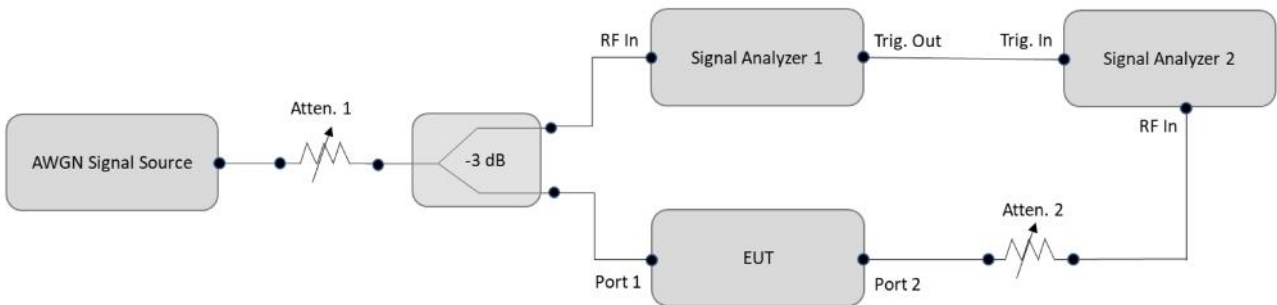

Figure 2. Contention-based protocol test setup, conducted method Step-by-Step Procedure, Conducted Setup

For Radiated measurement:

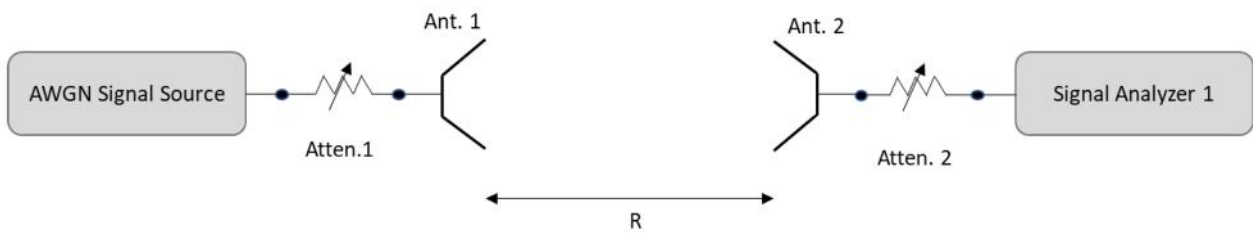

Figure 3. Contention-based protocol test setup, radiated method, power measurement

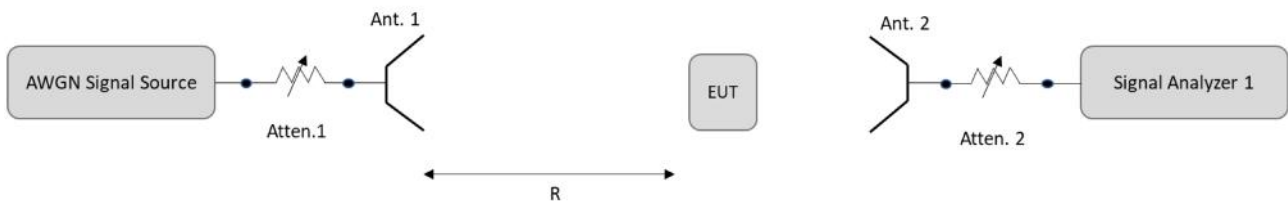

Figure 4. Contention-based protocol test setup, radiated method, detection threshold measurement

## 9.5 EUT OPERATING CONDITIONS

The EUT was Configured to be in normally transmitting mode with a constant duty cycle.

## 9.6 TEST RESULT

Please refer to the APPENDIX I.

## 10 LIST OF MEASURING EQUIPMENTS

Maximum e.i.r.p.						
Item	Kind of Equipment	Manufacturer	Type No.	Serial No.	Calibrated Date	Calibrated Until
1	Power Meter	Anritsu	ML2495A	1128008	2023/5/12	2024/5/11
2	Power Sensor	Anritsu	MA2411B	1126001	2023/5/12	2024/5/11

Maximum transmitter channel bandwidth & Maximum power spectral density & In-band emission (Mask)						
Item	Kind of Equipment	Manufacturer	Type No.	Serial No.	Calibrated Date	Calibrated Until
1	Spectrum Analyzer	R&S	FSP 40	100129	2023/3/27	2024/3/26

Undesirable Emissions						
Item	Kind of Equipment	Manufacturer	Type No.	Serial No.	Calibrated Date	Calibrated Until
1	Preamplifier	EMCI	EMC330N	980850	2023/9/6	2024/9/5
2	Preamplifier	EMCI	EMC118A45SE	980819	2023/3/7	2024/3/6
3	Pre-Amplifier	EMCI	EMC184045SE	980907	2023/9/21	2024/9/20
4	Preamplifier	EMCI	EMC001340	980579	2023/9/6	2024/9/5
5	Test Cable	EMCI	EMC104-SM-1000	180809	2023/7/10	2024/7/9
6	Test Cable	EMCI	EMC104-SM-SM-3000	220322	2023/3/14	2024/3/13
7	Test Cable	EMCI	EMC104-SM-SM-7000	220324	2023/3/14	2024/3/13
8	EXA Signal Analyzer	keysight	N9020B	MY57120120	2023/2/24	2024/2/23
9	Loop Ant	Electro-Metrics	EMCI-LPA600	291	2023/9/12	2024/9/11
10	Horn Antenna	RFSPIN	DRH18-E	211202A18EN	2023/5/12	2024/5/11
11	Horn Ant	Schwarzbeck	BBHA 9170D	1136	2023/5/12	2024/5/11
12	Log-bicon Antenna	Schwarzbeck	VULB9168	1369	2023/5/9	2024/5/8
13	6dB Attenuator	EMCI	EMCI-N-6-06	AT-06001	2023/5/9	2024/5/8
14	Test Cable	EMCI	EMC101G-KM-KM-3000	220329	2023/3/14	2024/3/13
15	Test Cable	EMCI	EMC102-KM-KM-1000	220327	2023/3/14	2024/3/13
16	Measurement Software	EZ	EZ EMC (Version NB-03A1-01)	N/A	N/A	N/A

AC Power Line Conducted Emissions						
Item	Kind of Equipment	Manufacturer	Type No.	Serial No.	Calibrated Date	Calibrated Until
1	TWO-LINE V-NETWORK	R&S	ENV216	101521	2023/9/13	2024/9/12
2	Test Cable	EMCI	EMCCFD300-BM-BMR-5000	220331	2023/3/30	2024/3/29
3	EMI Test Receiver	R&S	ESR 7	101433	2023/11/10	2024/11/9
4	Measurement Software	EZ	EZ EMC (Version NB-03A1-01)	N/A	N/A	N/A

Contention Based Protocol						
Item	Kind of Equipment	Manufacturer	Type No.	Serial No.	Calibrated Date	Calibrated Until
1	MXA Signal Analyzer	Keysight	N9020B	MY63490160	2024/2/6	2025/2/5
2	MXG Vector Signal Generator	Agilent	N5182B	MY51350711	2024/2/21	2025/2/20
3	Spectrum Analyzer	Keysight	N9010A	MY54200240	2023/6/26	2024/6/25

## 11 EUT TEST PHOTOS

Please refer to document Appendix No.: TP-2311H013-FCCP-1 (APPENDIX-TEST PHOTOS).

## 12 EUT PHOTOS

Please refer to document Appendix No.: EP-2311H013-1 (APPENDIX-EUT PHOTOS).

## APPENDIX A MAXIMUM E.I.R.P.

Operation Mode	Non-Beamforming mode
----------------	----------------------

Test Mode	IEEE 802.11ax (HE20)_ Ant 1	Tested Date	2024/1/2
-----------	-----------------------------	-------------	----------

Test Frequency (MHz)	Conducted Power (dBm)	Conducted Power (W)	E.I.R.P. (dBm)	E.I.R.P. Limit (dBm)	Result
5955	6.95	0.0050	10.56	30.00	Pass
6175	6.45	0.0044	10.06	30.00	Pass
6415	6.11	0.0041	9.72	30.00	Pass
6435	6.48	0.0044	10.09	30.00	Pass
6475	6.19	0.0042	9.80	30.00	Pass
6515	6.43	0.0044	10.04	30.00	Pass
6535	6.48	0.0044	10.09	30.00	Pass
6695	7.00	0.0050	10.61	30.00	Pass
6855	7.15	0.0052	10.76	30.00	Pass
6875	7.01	0.0050	10.62	30.00	Pass
6995	7.14	0.0052	10.75	30.00	Pass
7095	6.92	0.0049	10.53	30.00	Pass
7115	-11.82	0.0001	-8.21	30.00	Pass

Test Mode	IEEE 802.11ax (HE20)_ Ant 2	Tested Date	2024/1/2
-----------	-----------------------------	-------------	----------

Test Frequency (MHz)	Conducted Power (dBm)	Conducted Power (W)	E.I.R.P. (dBm)	E.I.R.P. Limit (dBm)	Result
5955	6.07	0.0040	9.68	30.00	Pass
6175	5.59	0.0036	9.20	30.00	Pass
6415	5.84	0.0038	9.45	30.00	Pass
6435	5.64	0.0037	9.25	30.00	Pass
6475	5.63	0.0037	9.24	30.00	Pass
6515	5.61	0.0036	9.22	30.00	Pass
6535	5.40	0.0035	9.01	30.00	Pass
6695	5.87	0.0039	9.48	30.00	Pass
6855	5.92	0.0039	9.53	30.00	Pass
6875	6.06	0.0040	9.67	30.00	Pass
6995	6.15	0.0041	9.76	30.00	Pass
7095	6.16	0.0041	9.77	30.00	Pass
7115	-14.00	0.0000	-10.39	30.00	Pass



Test Mode	IEEE 802.11ax (HE20)_Total	Tested Date	2024/1/2
-----------	----------------------------	-------------	----------

Test Frequency (MHz)	Conducted Power (dBm)	Conducted Power (W)	E.I.R.P. (dBm)	E.I.R.P. Limit (dBm)	Result
5955	9.54	0.0090	13.15	30.00	Pass
6175	9.05	0.0080	12.66	30.00	Pass
6415	8.99	0.0079	12.60	30.00	Pass
6435	9.09	0.0081	12.70	30.00	Pass
6475	8.93	0.0078	12.54	30.00	Pass
6515	9.05	0.0080	12.66	30.00	Pass
6535	8.98	0.0079	12.59	30.00	Pass
6695	9.48	0.0089	13.09	30.00	Pass
6855	9.59	0.0091	13.20	30.00	Pass
6875	9.57	0.0091	13.18	30.00	Pass
6995	9.68	0.0093	13.29	30.00	Pass
7095	9.57	0.0091	13.18	30.00	Pass
7115	-9.77	0.0001	-6.16	30.00	Pass

Test Mode	IEEE 802.11ax (HE40)_ Ant 1	Tested Date	2024/1/2
-----------	-----------------------------	-------------	----------

Test Frequency (MHz)	Conducted Power (dBm)	Conducted Power (W)	E.I.R.P. (dBm)	E.I.R.P. Limit (dBm)	Result
5965	11.35	0.0136	14.96	30.00	Pass
6165	11.68	0.0147	15.29	30.00	Pass
6405	10.88	0.0122	14.49	30.00	Pass
6445	10.34	0.0108	13.95	30.00	Pass
6485	10.53	0.0113	14.14	30.00	Pass
6525	10.62	0.0115	14.23	30.00	Pass
6685	11.07	0.0128	14.68	30.00	Pass
6845	11.81	0.0152	15.42	30.00	Pass
6885	11.30	0.0135	14.91	30.00	Pass
7085	10.97	0.0125	14.58	30.00	Pass

Test Mode	IEEE 802.11ax (HE40)_ Ant 2	Tested Date	2024/1/2
-----------	-----------------------------	-------------	----------

Test Frequency (MHz)	Conducted Power (dBm)	Conducted Power (W)	E.I.R.P. (dBm)	E.I.R.P. Limit (dBm)	Result
5965	10.02	0.0100	13.63	30.00	Pass
6165	10.55	0.0114	14.16	30.00	Pass
6405	9.65	0.0092	13.26	30.00	Pass
6445	9.21	0.0083	12.82	30.00	Pass
6485	9.26	0.0084	12.87	30.00	Pass
6525	9.30	0.0085	12.91	30.00	Pass
6685	9.87	0.0097	13.48	30.00	Pass
6845	10.42	0.0110	14.03	30.00	Pass
6885	9.75	0.0094	13.36	30.00	Pass
7085	9.91	0.0098	13.52	30.00	Pass

Test Mode	IEEE 802.11ax (HE40)_ Total	Tested Date	2024/1/2
-----------	-----------------------------	-------------	----------

Test Frequency (MHz)	Conducted Power (dBm)	Conducted Power (W)	E.I.R.P. (dBm)	E.I.R.P. Limit (dBm)	Result
5965	13.75	0.0237	17.36	30.00	Pass
6165	14.16	0.0261	17.77	30.00	Pass
6405	13.32	0.0215	16.93	30.00	Pass
6445	12.82	0.0192	16.43	30.00	Pass
6485	12.95	0.0197	16.56	30.00	Pass
6525	13.02	0.0200	16.63	30.00	Pass
6685	13.52	0.0225	17.13	30.00	Pass
6845	14.18	0.0262	17.79	30.00	Pass
6885	13.60	0.0229	17.21	30.00	Pass
7085	13.48	0.0223	17.09	30.00	Pass

Test Mode	IEEE 802.11ax (HE80)_ Ant 1	Tested Date	2024/1/2
-----------	-----------------------------	-------------	----------

Test Frequency (MHz)	Conducted Power (dBm)	Conducted Power (W)	E.I.R.P. (dBm)	E.I.R.P. Limit (dBm)	Result
5985	14.05	0.0254	17.66	30.00	Pass
6145	13.35	0.0216	16.96	30.00	Pass
6385	13.18	0.0208	16.79	30.00	Pass
6465	13.24	0.0211	16.85	30.00	Pass
6545	13.23	0.0210	16.84	30.00	Pass
6625	13.26	0.0212	16.87	30.00	Pass
6785	13.81	0.0240	17.42	30.00	Pass
6865	13.94	0.0248	17.55	30.00	Pass
6945	14.08	0.0256	17.69	30.00	Pass
7025	13.24	0.0211	16.85	30.00	Pass

Test Mode	IEEE 802.11ax (HE80)_ Ant 2	Tested Date	2024/1/2
-----------	-----------------------------	-------------	----------

Test Frequency (MHz)	Conducted Power (dBm)	Conducted Power (W)	E.I.R.P. (dBm)	E.I.R.P. Limit (dBm)	Result
5985	12.76	0.0189	16.37	30.00	Pass
6145	12.45	0.0176	16.06	30.00	Pass
6385	12.16	0.0164	15.77	30.00	Pass
6465	12.28	0.0169	15.89	30.00	Pass
6545	12.36	0.0172	15.97	30.00	Pass
6625	12.06	0.0161	15.67	30.00	Pass
6785	12.68	0.0185	16.29	30.00	Pass
6865	12.65	0.0184	16.26	30.00	Pass
6945	12.82	0.0191	16.43	30.00	Pass
7025	12.35	0.0172	15.96	30.00	Pass

Test Mode	IEEE 802.11ax (HE80)_ Total	Tested Date	2024/1/2
-----------	-----------------------------	-------------	----------

Test Frequency (MHz)	Conducted Power (dBm)	Conducted Power (W)	E.I.R.P. (dBm)	E.I.R.P. Limit (dBm)	Result
5985	16.46	0.0443	20.07	30.00	Pass
6145	15.93	0.0392	19.54	30.00	Pass
6385	15.71	0.0372	19.32	30.00	Pass
6465	15.80	0.0380	19.41	30.00	Pass
6545	15.83	0.0383	19.44	30.00	Pass
6625	15.71	0.0373	19.32	30.00	Pass
6785	16.29	0.0426	19.90	30.00	Pass
6865	16.35	0.0432	19.96	30.00	Pass
6945	16.51	0.0447	20.12	30.00	Pass
7025	15.83	0.0383	19.44	30.00	Pass

Test Mode	IEEE 802.11ax (HE160)_ Ant 1	Tested Date	2024/1/2
-----------	------------------------------	-------------	----------

Test Frequency (MHz)	Conducted Power (dBm)	Conducted Power (W)	E.I.R.P. (dBm)	E.I.R.P. Limit (dBm)	Result
6025	16.62	0.0459	20.23	30.00	Pass
6345	16.11	0.0408	19.72	30.00	Pass
6505	16.15	0.0412	19.76	30.00	Pass
6665	16.58	0.0455	20.19	30.00	Pass
6985	16.55	0.0452	20.16	30.00	Pass

Test Mode	IEEE 802.11ax (HE160)_ Ant 2	Tested Date	2024/1/2
-----------	------------------------------	-------------	----------

Test Frequency (MHz)	Conducted Power (dBm)	Conducted Power (W)	E.I.R.P. (dBm)	E.I.R.P. Limit (dBm)	Result
6025	15.71	0.0372	19.32	30.00	Pass
6345	15.09	0.0323	18.70	30.00	Pass
6505	15.28	0.0337	18.89	30.00	Pass
6665	15.46	0.0352	19.07	30.00	Pass
6985	15.64	0.0366	19.25	30.00	Pass

Test Mode	IEEE 802.11ax (HE160)_ Total	Tested Date	2024/1/2
-----------	------------------------------	-------------	----------

Test Frequency (MHz)	Conducted Power (dBm)	Conducted Power (W)	E.I.R.P. (dBm)	E.I.R.P. Limit (dBm)	Result
6025	19.20	0.0832	22.81	30.00	Pass
6345	18.64	0.0731	22.25	30.00	Pass
6505	18.75	0.0749	22.36	30.00	Pass
6665	19.07	0.0807	22.68	30.00	Pass
6985	19.13	0.0818	22.74	30.00	Pass

Test Mode	IEEE 802.11be (EHT20)_ Ant 1	Tested Date	2024/1/2
-----------	------------------------------	-------------	----------

Test Frequency (MHz)	Conducted Power (dBm)	Conducted Power (W)	E.I.R.P. (dBm)	E.I.R.P. Limit (dBm)	Result
5955	7.39	0.0055	11.00	30.00	Pass
6175	7.46	0.0056	11.07	30.00	Pass
6415	7.17	0.0052	10.78	30.00	Pass
6435	7.08	0.0051	10.69	30.00	Pass
6475	6.25	0.0042	9.86	30.00	Pass
6515	7.47	0.0056	11.08	30.00	Pass
6535	7.37	0.0055	10.98	30.00	Pass
6695	7.51	0.0056	11.12	30.00	Pass
6855	7.99	0.0063	11.60	30.00	Pass
6875	7.81	0.0060	11.42	30.00	Pass
6995	7.80	0.0060	11.41	30.00	Pass
7095	7.92	0.0062	11.53	30.00	Pass
7115	-9.87	0.0001	-6.26	30.00	Pass

Test Mode	IEEE 802.11be (EHT20)_ Ant 2	Tested Date	2024/1/2
-----------	------------------------------	-------------	----------

Test Frequency (MHz)	Conducted Power (dBm)	Conducted Power (W)	E.I.R.P. (dBm)	E.I.R.P. Limit (dBm)	Result
5955	6.35	0.0043	9.96	30.00	Pass
6175	6.55	0.0045	10.16	30.00	Pass
6415	6.48	0.0044	10.09	30.00	Pass
6435	6.28	0.0042	9.89	30.00	Pass
6475	6.38	0.0043	9.99	30.00	Pass
6515	6.51	0.0045	10.12	30.00	Pass
6535	6.42	0.0044	10.03	30.00	Pass
6695	6.38	0.0043	9.99	30.00	Pass
6855	7.46	0.0056	11.07	30.00	Pass
6875	7.18	0.0052	10.79	30.00	Pass
6995	7.63	0.0058	11.24	30.00	Pass
7095	7.47	0.0056	11.08	30.00	Pass
7115	-11.48	0.0001	-7.87	30.00	Pass

Test Mode	IEEE 802.11be (EHT20)_ Total	Tested Date	2024/1/2
-----------	------------------------------	-------------	----------

Test Frequency (MHz)	Conducted Power (dBm)	Conducted Power (W)	E.I.R.P. (dBm)	E.I.R.P. Limit (dBm)	Result
5955	9.91	0.0098	13.52	30.00	Pass
6175	10.04	0.0101	13.65	30.00	Pass
6415	9.85	0.0097	13.46	30.00	Pass
6435	9.71	0.0094	13.32	30.00	Pass
6475	9.33	0.0086	12.94	30.00	Pass
6515	10.03	0.0101	13.64	30.00	Pass
6535	9.93	0.0098	13.54	30.00	Pass
6695	9.99	0.0100	13.60	30.00	Pass
6855	10.74	0.0119	14.35	30.00	Pass
6875	10.52	0.0113	14.13	30.00	Pass
6995	10.73	0.0118	14.34	30.00	Pass
7095	10.71	0.0118	14.32	30.00	Pass
7115	-7.59	0.0002	-3.98	30.00	Pass

Test Mode	IEEE 802.11be (EHT40)_ Ant 1	Tested Date	2024/1/2
-----------	------------------------------	-------------	----------

Test Frequency (MHz)	Conducted Power (dBm)	Conducted Power (W)	E.I.R.P. (dBm)	E.I.R.P. Limit (dBm)	Result
5965	11.23	0.0133	14.84	30.00	Pass
6165	11.04	0.0127	14.65	30.00	Pass
6405	10.72	0.0118	14.33	30.00	Pass
6445	10.70	0.0117	14.31	30.00	Pass
6485	10.89	0.0123	14.50	30.00	Pass
6525	11.04	0.0127	14.65	30.00	Pass
6685	10.77	0.0119	14.38	30.00	Pass
6845	11.21	0.0132	14.82	30.00	Pass
6885	11.09	0.0129	14.70	30.00	Pass
7085	10.87	0.0122	14.48	30.00	Pass

Test Mode	IEEE 802.11be (EHT40)_ Ant 2	Tested Date	2024/1/2
-----------	------------------------------	-------------	----------

Test Frequency (MHz)	Conducted Power (dBm)	Conducted Power (W)	E.I.R.P. (dBm)	E.I.R.P. Limit (dBm)	Result
5965	9.99	0.0100	13.60	30.00	Pass
6165	10.02	0.0100	13.63	30.00	Pass
6405	9.54	0.0090	13.15	30.00	Pass
6445	9.77	0.0095	13.38	30.00	Pass
6485	9.75	0.0094	13.36	30.00	Pass
6525	10.01	0.0100	13.62	30.00	Pass
6685	9.51	0.0089	13.12	30.00	Pass
6845	10.00	0.0100	13.61	30.00	Pass
6885	9.64	0.0092	13.25	30.00	Pass
7085	9.86	0.0097	13.47	30.00	Pass

Test Mode	IEEE 802.11be (EHT40)_ Total	Tested Date	2024/1/2
-----------	------------------------------	-------------	----------

Test Frequency (MHz)	Conducted Power (dBm)	Conducted Power (W)	E.I.R.P. (dBm)	E.I.R.P. Limit (dBm)	Result
5965	13.66	0.0233	17.27	30.00	Pass
6165	13.57	0.0228	17.18	30.00	Pass
6405	13.18	0.0208	16.79	30.00	Pass
6445	13.27	0.0212	16.88	30.00	Pass
6485	13.37	0.0217	16.98	30.00	Pass
6525	13.57	0.0227	17.18	30.00	Pass
6685	13.20	0.0209	16.81	30.00	Pass
6845	13.66	0.0232	17.27	30.00	Pass
6885	13.44	0.0221	17.05	30.00	Pass
7085	13.40	0.0219	17.01	30.00	Pass

Test Mode	IEEE 802.11be (EHT80)_ Ant 1	Tested Date	2024/1/2
-----------	------------------------------	-------------	----------

Test Frequency (MHz)	Conducted Power (dBm)	Conducted Power (W)	E.I.R.P. (dBm)	E.I.R.P. Limit (dBm)	Result
5985	14.68	0.0294	18.29	30.00	Pass
6145	13.84	0.0242	17.45	30.00	Pass
6385	13.81	0.0240	17.42	30.00	Pass
6465	13.80	0.0240	17.41	30.00	Pass
6545	13.84	0.0242	17.45	30.00	Pass
6625	14.41	0.0276	18.02	30.00	Pass
6785	13.95	0.0248	17.56	30.00	Pass
6865	14.02	0.0252	17.63	30.00	Pass
6945	14.14	0.0259	17.75	30.00	Pass
7025	13.75	0.0237	17.36	30.00	Pass

Test Mode	IEEE 802.11be (EHT80)_ Ant 2	Tested Date	2024/1/2
-----------	------------------------------	-------------	----------

Test Frequency (MHz)	Conducted Power (dBm)	Conducted Power (W)	E.I.R.P. (dBm)	E.I.R.P. Limit (dBm)	Result
5985	13.43	0.0220	17.04	30.00	Pass
6145	13.12	0.0205	16.73	30.00	Pass
6385	12.74	0.0188	16.35	30.00	Pass
6465	12.96	0.0198	16.57	30.00	Pass
6545	13.00	0.0200	16.61	30.00	Pass
6625	13.30	0.0214	16.91	30.00	Pass
6785	12.96	0.0198	16.57	30.00	Pass
6865	12.80	0.0191	16.41	30.00	Pass
6945	12.92	0.0196	16.53	30.00	Pass
7025	12.89	0.0195	16.50	30.00	Pass

Test Mode	IEEE 802.11be (EHT80)_ Total	Tested Date	2024/1/2
-----------	------------------------------	-------------	----------

Test Frequency (MHz)	Conducted Power (dBm)	Conducted Power (W)	E.I.R.P. (dBm)	E.I.R.P. Limit (dBm)	Result
5985	17.11	0.0514	20.72	30.00	Pass
6145	16.51	0.0447	20.12	30.00	Pass
6385	16.32	0.0428	19.93	30.00	Pass
6465	16.41	0.0438	20.02	30.00	Pass
6545	16.45	0.0442	20.06	30.00	Pass
6625	16.90	0.0490	20.51	30.00	Pass
6785	16.49	0.0446	20.10	30.00	Pass
6865	16.46	0.0443	20.07	30.00	Pass
6945	16.58	0.0455	20.19	30.00	Pass
7025	16.35	0.0432	19.96	30.00	Pass

Test Mode	IEEE 802.11be (EHT160)_ Ant 1	Tested Date	2024/1/2
-----------	-------------------------------	-------------	----------

Test Frequency (MHz)	Conducted Power (dBm)	Conducted Power (W)	E.I.R.P. (dBm)	E.I.R.P. Limit (dBm)	Result
6025	17.13	0.0516	20.74	30.00	Pass
6345	16.72	0.0470	20.33	30.00	Pass
6505	16.65	0.0462	20.26	30.00	Pass
6665	16.75	0.0473	20.36	30.00	Pass
6985	16.65	0.0462	20.26	30.00	Pass

Test Mode	IEEE 802.11be (EHT160)_ Ant 2	Tested Date	2024/1/2
-----------	-------------------------------	-------------	----------

Test Frequency (MHz)	Conducted Power (dBm)	Conducted Power (W)	E.I.R.P. (dBm)	E.I.R.P. Limit (dBm)	Result
6025	16.23	0.0420	19.84	30.00	Pass
6345	15.80	0.0380	19.41	30.00	Pass
6505	15.73	0.0374	19.34	30.00	Pass
6665	15.63	0.0366	19.24	30.00	Pass
6985	15.67	0.0369	19.28	30.00	Pass

Test Mode	IEEE 802.11be (EHT160)_ Total	Tested Date	2024/1/2
-----------	-------------------------------	-------------	----------

Test Frequency (MHz)	Conducted Power (dBm)	Conducted Power (W)	E.I.R.P. (dBm)	E.I.R.P. Limit (dBm)	Result
6025	19.71	0.0936	23.32	30.00	Pass
6345	19.29	0.0850	22.90	30.00	Pass
6505	19.22	0.0836	22.83	30.00	Pass
6665	19.24	0.0839	22.85	30.00	Pass
6985	19.20	0.0831	22.81	30.00	Pass



Test Mode	IEEE 802.11be (EHT320)_ Ant 1	Tested Date	2024/1/2
-----------	-------------------------------	-------------	----------

Test Frequency (MHz)	Conducted Power (dBm)	Conducted Power (W)	E.I.R.P. (dBm)	E.I.R.P. Limit (dBm)	Result
6105	19.85	0.0966	23.46	30.00	Pass
6265	19.50	0.0891	23.11	30.00	Pass
6425	19.85	0.0966	23.46	30.00	Pass
6585	20.10	0.1023	23.71	30.00	Pass
6745	19.92	0.0982	23.53	30.00	Pass
6905	19.84	0.0964	23.45	30.00	Pass

Test Mode	IEEE 802.11be (EHT320)_ Ant 2	Tested Date	2024/1/2
-----------	-------------------------------	-------------	----------

Test Frequency (MHz)	Conducted Power (dBm)	Conducted Power (W)	E.I.R.P. (dBm)	E.I.R.P. Limit (dBm)	Result
6105	19.11	0.0815	22.72	30.00	Pass
6265	18.76	0.0752	22.37	30.00	Pass
6425	18.91	0.0778	22.52	30.00	Pass
6585	18.74	0.0748	22.35	30.00	Pass
6745	18.82	0.0762	22.43	30.00	Pass
6905	18.04	0.0637	21.65	30.00	Pass

Test Mode	IEEE 802.11be (EHT320)_ Total	Tested Date	2024/1/2
-----------	-------------------------------	-------------	----------

Test Frequency (MHz)	Conducted Power (dBm)	Conducted Power (W)	E.I.R.P. (dBm)	E.I.R.P. Limit (dBm)	Result
6105	22.51	0.1781	26.12	30.00	Pass
6265	22.16	0.1643	25.77	30.00	Pass
6425	22.42	0.1744	26.03	30.00	Pass
6585	22.48	0.1771	26.09	30.00	Pass
6745	22.42	0.1744	26.03	30.00	Pass
6905	22.04	0.1601	25.65	30.00	Pass

Operation Mode	Beamforming mode
----------------	------------------

Test Mode	IEEE 802.11ax (HE20)_ Ant 1	Tested Date	2024/1/2
-----------	-----------------------------	-------------	----------

Test Frequency (MHz)	Conducted Power (dBm)	Conducted Power (W)	E.I.R.P. (dBm)	E.I.R.P. Limit (dBm)	Result
5955	6.43	0.0044	10.04	30.00	Pass
6175	6.01	0.0040	9.62	30.00	Pass
6415	5.72	0.0037	9.33	30.00	Pass
6435	5.98	0.0040	9.59	30.00	Pass
6475	5.77	0.0038	9.38	30.00	Pass
6515	5.87	0.0039	9.48	30.00	Pass
6535	6.02	0.0040	9.63	30.00	Pass
6695	6.69	0.0047	10.30	30.00	Pass
6855	6.75	0.0047	10.36	30.00	Pass
6875	6.58	0.0045	10.19	30.00	Pass
6995	6.71	0.0047	10.32	30.00	Pass
7095	6.53	0.0045	10.14	30.00	Pass
7115	-12.08	0.0001	-8.47	30.00	Pass

Test Mode	IEEE 802.11ax (HE20)_ Ant 2	Tested Date	2024/1/2
-----------	-----------------------------	-------------	----------

Test Frequency (MHz)	Conducted Power (dBm)	Conducted Power (W)	E.I.R.P. (dBm)	E.I.R.P. Limit (dBm)	Result
5955	5.77	0.0038	9.38	30.00	Pass
6175	5.51	0.0036	9.12	30.00	Pass
6415	5.41	0.0035	9.02	30.00	Pass
6435	5.21	0.0033	8.82	30.00	Pass
6475	5.28	0.0034	8.89	30.00	Pass
6515	5.19	0.0033	8.80	30.00	Pass
6535	5.01	0.0032	8.62	30.00	Pass
6695	5.52	0.0036	9.13	30.00	Pass
6855	5.46	0.0035	9.07	30.00	Pass
6875	5.68	0.0037	9.29	30.00	Pass
6995	5.69	0.0037	9.30	30.00	Pass
7095	5.68	0.0037	9.29	30.00	Pass
7115	-14.38	0.0000	-10.77	30.00	Pass

Test Mode	IEEE 802.11ax (HE20)_Total	Tested Date	2024/1/2
-----------	----------------------------	-------------	----------

Test Frequency (MHz)	Conducted Power (dBm)	Conducted Power (W)	E.I.R.P. (dBm)	E.I.R.P. Limit (dBm)	Result
5955	9.12	0.0082	15.73	30.00	Pass
6175	8.78	0.0075	15.39	30.00	Pass
6415	8.58	0.0072	15.19	30.00	Pass
6435	8.62	0.0073	15.23	30.00	Pass
6475	8.54	0.0071	15.15	30.00	Pass
6515	8.55	0.0072	15.16	30.00	Pass
6535	8.55	0.0072	15.16	30.00	Pass
6695	9.15	0.0082	15.76	30.00	Pass
6855	9.16	0.0082	15.77	30.00	Pass
6875	9.16	0.0082	15.77	30.00	Pass
6995	9.24	0.0084	15.85	30.00	Pass
7095	9.14	0.0082	15.75	30.00	Pass
7115	-10.07	0.0001	-3.46	30.00	Pass

Test Mode	IEEE 802.11ax (HE40)_ Ant 1	Tested Date	2024/1/2
-----------	-----------------------------	-------------	----------

Test Frequency (MHz)	Conducted Power (dBm)	Conducted Power (W)	E.I.R.P. (dBm)	E.I.R.P. Limit (dBm)	Result
5965	10.96	0.0125	14.57	30.00	Pass
6165	11.19	0.0132	14.80	30.00	Pass
6405	10.49	0.0112	14.10	30.00	Pass
6445	10.02	0.0100	13.63	30.00	Pass
6485	10.08	0.0102	13.69	30.00	Pass
6525	10.25	0.0106	13.86	30.00	Pass
6685	10.62	0.0115	14.23	30.00	Pass
6845	11.36	0.0137	14.97	30.00	Pass
6885	10.82	0.0121	14.43	30.00	Pass
7085	10.68	0.0117	14.29	30.00	Pass

Test Mode	IEEE 802.11ax (HE40)_ Ant 2	Tested Date	2024/1/2
-----------	-----------------------------	-------------	----------

Test Frequency (MHz)	Conducted Power (dBm)	Conducted Power (W)	E.I.R.P. (dBm)	E.I.R.P. Limit (dBm)	Result
5965	9.62	0.0092	13.23	30.00	Pass
6165	10.08	0.0102	13.69	30.00	Pass
6405	9.18	0.0083	12.79	30.00	Pass
6445	8.89	0.0077	12.50	30.00	Pass
6485	8.92	0.0078	12.53	30.00	Pass
6525	8.84	0.0077	12.45	30.00	Pass
6685	9.31	0.0085	12.92	30.00	Pass
6845	10.05	0.0101	13.66	30.00	Pass
6885	9.43	0.0088	13.04	30.00	Pass
7085	9.54	0.0090	13.15	30.00	Pass

Test Mode	IEEE 802.11ax (HE40)_ Total	Tested Date	2024/1/2
-----------	-----------------------------	-------------	----------

Test Frequency (MHz)	Conducted Power (dBm)	Conducted Power (W)	E.I.R.P. (dBm)	E.I.R.P. Limit (dBm)	Result
5965	13.35	0.0216	19.96	30.00	Pass
6165	13.68	0.0233	20.29	30.00	Pass
6405	12.89	0.0195	19.50	30.00	Pass
6445	12.50	0.0178	19.11	30.00	Pass
6485	12.55	0.0180	19.16	30.00	Pass
6525	12.61	0.0182	19.22	30.00	Pass
6685	13.02	0.0201	19.63	30.00	Pass
6845	13.76	0.0238	20.37	30.00	Pass
6885	13.19	0.0208	19.80	30.00	Pass
7085	13.16	0.0207	19.77	30.00	Pass

Test Mode	IEEE 802.11ax (HE80)_ Ant 1	Tested Date	2024/1/2
-----------	-----------------------------	-------------	----------

Test Frequency (MHz)	Conducted Power (dBm)	Conducted Power (W)	E.I.R.P. (dBm)	E.I.R.P. Limit (dBm)	Result
5985	13.59	0.0229	17.20	30.00	Pass
6145	13.01	0.0200	16.62	30.00	Pass
6385	12.72	0.0187	16.33	30.00	Pass
6465	12.80	0.0191	16.41	30.00	Pass
6545	12.84	0.0192	16.45	30.00	Pass
6625	13.26	0.0212	16.87	30.00	Pass
6785	13.51	0.0224	17.12	30.00	Pass
6865	13.53	0.0225	17.14	30.00	Pass
6945	13.62	0.0230	17.23	30.00	Pass
7025	12.75	0.0188	16.36	30.00	Pass

Test Mode	IEEE 802.11ax (HE80)_ Ant 2	Tested Date	2024/1/2
-----------	-----------------------------	-------------	----------

Test Frequency (MHz)	Conducted Power (dBm)	Conducted Power (W)	E.I.R.P. (dBm)	E.I.R.P. Limit (dBm)	Result
5985	12.42	0.0175	16.03	30.00	Pass
6145	12.21	0.0166	15.82	30.00	Pass
6385	11.85	0.0153	15.46	30.00	Pass
6465	11.84	0.0153	15.45	30.00	Pass
6545	12.02	0.0159	15.63	30.00	Pass
6625	12.06	0.0161	15.67	30.00	Pass
6785	12.25	0.0168	15.86	30.00	Pass
6865	12.18	0.0165	15.79	30.00	Pass
6945	12.36	0.0172	15.97	30.00	Pass
7025	11.93	0.0156	15.54	30.00	Pass

Test Mode	IEEE 802.11ax (HE80)_ Total	Tested Date	2024/1/2
-----------	-----------------------------	-------------	----------

Test Frequency (MHz)	Conducted Power (dBm)	Conducted Power (W)	E.I.R.P. (dBm)	E.I.R.P. Limit (dBm)	Result
5985	13.35	0.0216	19.96	30.00	Pass
6145	15.93	0.0392	22.54	30.00	Pass
6385	15.71	0.0372	22.32	30.00	Pass
6465	15.80	0.0380	22.41	30.00	Pass
6545	15.83	0.0383	22.44	30.00	Pass
6625	15.71	0.0373	22.32	30.00	Pass
6785	16.29	0.0426	22.90	30.00	Pass
6865	16.35	0.0432	22.96	30.00	Pass
6945	16.51	0.0447	23.12	30.00	Pass
7025	15.83	0.0383	22.44	30.00	Pass

Test Mode	IEEE 802.11ax (HE160)_ Ant 1	Tested Date	2024/1/2
-----------	------------------------------	-------------	----------

Test Frequency (MHz)	Conducted Power (dBm)	Conducted Power (W)	E.I.R.P. (dBm)	E.I.R.P. Limit (dBm)	Result
6025	16.20	0.0417	19.81	30.00	Pass
6345	15.57	0.0361	19.18	30.00	Pass
6505	15.68	0.0370	19.29	30.00	Pass
6665	16.09	0.0406	19.70	30.00	Pass
6985	16.06	0.0404	19.67	30.00	Pass

Test Mode	IEEE 802.11ax (HE160)_ Ant 2	Tested Date	2024/1/2
-----------	------------------------------	-------------	----------

Test Frequency (MHz)	Conducted Power (dBm)	Conducted Power (W)	E.I.R.P. (dBm)	E.I.R.P. Limit (dBm)	Result
6025	15.28	0.0337	18.89	30.00	Pass
6345	14.61	0.0289	18.22	30.00	Pass
6505	14.85	0.0305	18.46	30.00	Pass
6665	15.02	0.0318	18.63	30.00	Pass
6985	15.14	0.0327	18.75	30.00	Pass

Test Mode	IEEE 802.11ax (HE160)_ Total	Tested Date	2024/1/2
-----------	------------------------------	-------------	----------

Test Frequency (MHz)	Conducted Power (dBm)	Conducted Power (W)	E.I.R.P. (dBm)	E.I.R.P. Limit (dBm)	Result
6025	18.77	0.0754	25.38	30.00	Pass
6345	18.13	0.0650	24.74	30.00	Pass
6505	18.30	0.0675	24.91	30.00	Pass
6665	18.60	0.0724	25.21	30.00	Pass
6985	18.63	0.0730	25.24	30.00	Pass

Test Mode	IEEE 802.11be (EHT20)_ Ant 1	Tested Date	2024/1/2
-----------	------------------------------	-------------	----------

Test Frequency (MHz)	Conducted Power (dBm)	Conducted Power (W)	E.I.R.P. (dBm)	E.I.R.P. Limit (dBm)	Result
5955	6.91	0.0049	10.52	30.00	Pass
6175	7.04	0.0051	10.65	30.00	Pass
6415	6.76	0.0047	10.37	30.00	Pass
6435	6.61	0.0046	10.22	30.00	Pass
6475	5.81	0.0038	9.42	30.00	Pass
6515	7.01	0.0050	10.62	30.00	Pass
6535	6.94	0.0049	10.55	30.00	Pass
6695	7.00	0.0050	10.61	30.00	Pass
6855	7.45	0.0056	11.06	30.00	Pass
6875	7.31	0.0054	10.92	30.00	Pass
6995	7.32	0.0054	10.93	30.00	Pass
7095	7.92	0.0062	11.53	30.00	Pass
7115	-10.05	0.0001	-6.44	30.00	Pass

Test Mode	IEEE 802.11be (EHT20)_ Ant 2	Tested Date	2024/1/2
-----------	------------------------------	-------------	----------

Test Frequency (MHz)	Conducted Power (dBm)	Conducted Power (W)	E.I.R.P. (dBm)	E.I.R.P. Limit (dBm)	Result
5955	5.89	0.0039	9.50	30.00	Pass
6175	6.10	0.0041	9.71	30.00	Pass
6415	6.01	0.0040	9.62	30.00	Pass
6435	5.82	0.0038	9.43	30.00	Pass
6475	5.84	0.0038	9.45	30.00	Pass
6515	6.05	0.0040	9.66	30.00	Pass
6535	6.03	0.0040	9.64	30.00	Pass
6695	5.96	0.0039	9.57	30.00	Pass
6855	6.94	0.0049	10.55	30.00	Pass
6875	6.61	0.0046	10.22	30.00	Pass
6995	7.11	0.0051	10.72	30.00	Pass
7095	7.47	0.0056	11.08	30.00	Pass
7115	-11.71	0.0001	-8.10	30.00	Pass

Test Mode	IEEE 802.11be (EHT20)_ Total	Tested Date	2024/1/2
-----------	------------------------------	-------------	----------

Test Frequency (MHz)	Conducted Power (dBm)	Conducted Power (W)	E.I.R.P. (dBm)	E.I.R.P. Limit (dBm)	Result
5955	9.44	0.0088	16.05	30.00	Pass
6175	9.61	0.0091	16.22	30.00	Pass
6415	9.41	0.0087	16.02	30.00	Pass
6435	9.24	0.0084	15.85	30.00	Pass
6475	8.84	0.0076	15.45	30.00	Pass
6515	9.57	0.0091	16.18	30.00	Pass
6535	9.52	0.0090	16.13	30.00	Pass
6695	9.52	0.0090	16.13	30.00	Pass
6855	10.21	0.0105	16.82	30.00	Pass
6875	9.98	0.0100	16.59	30.00	Pass
6995	10.23	0.0105	16.84	30.00	Pass
7095	10.71	0.0118	17.32	30.00	Pass
7115	-7.79	0.0002	-1.18	30.00	Pass

Test Mode	IEEE 802.11be (EHT40)_ Ant 1	Tested Date	2024/1/2
-----------	------------------------------	-------------	----------

Test Frequency (MHz)	Conducted Power (dBm)	Conducted Power (W)	E.I.R.P. (dBm)	E.I.R.P. Limit (dBm)	Result
5965	10.75	0.0119	14.36	30.00	Pass
6165	10.58	0.0114	14.19	30.00	Pass
6405	10.24	0.0106	13.85	30.00	Pass
6445	10.23	0.0105	13.84	30.00	Pass
6485	10.40	0.0110	14.01	30.00	Pass
6525	10.58	0.0114	14.19	30.00	Pass
6685	10.32	0.0108	13.93	30.00	Pass
6845	10.76	0.0119	14.37	30.00	Pass
6885	10.61	0.0115	14.22	30.00	Pass
7085	10.41	0.0110	14.02	30.00	Pass

Test Mode	IEEE 802.11be (EHT40)_ Ant 2	Tested Date	2024/1/2
-----------	------------------------------	-------------	----------

Test Frequency (MHz)	Conducted Power (dBm)	Conducted Power (W)	E.I.R.P. (dBm)	E.I.R.P. Limit (dBm)	Result
5965	9.59	0.0091	13.20	30.00	Pass
6165	9.56	0.0090	13.17	30.00	Pass
6405	9.14	0.0082	12.75	30.00	Pass
6445	9.32	0.0086	12.93	30.00	Pass
6485	9.30	0.0085	12.91	30.00	Pass
6525	9.62	0.0092	13.23	30.00	Pass
6685	9.04	0.0080	12.65	30.00	Pass
6845	9.40	0.0087	13.01	30.00	Pass
6885	9.13	0.0082	12.74	30.00	Pass
7085	9.38	0.0087	12.99	30.00	Pass

Test Mode	IEEE 802.11be (EHT40)_ Total	Tested Date	2024/1/2
-----------	------------------------------	-------------	----------

Test Frequency (MHz)	Conducted Power (dBm)	Conducted Power (W)	E.I.R.P. (dBm)	E.I.R.P. Limit (dBm)	Result
5965	13.22	0.0210	19.83	30.00	Pass
6165	13.11	0.0205	19.72	30.00	Pass
6405	12.74	0.0188	19.35	30.00	Pass
6445	12.81	0.0191	19.42	30.00	Pass
6485	12.90	0.0195	19.51	30.00	Pass
6525	13.14	0.0206	19.75	30.00	Pass
6685	12.74	0.0188	19.35	30.00	Pass
6845	13.14	0.0206	19.75	30.00	Pass
6885	12.94	0.0197	19.55	30.00	Pass
7085	12.94	0.0197	19.55	30.00	Pass



Test Mode	IEEE 802.11be (EHT80)_ Ant 1	Tested Date	2024/1/2
-----------	------------------------------	-------------	----------

Test Frequency (MHz)	Conducted Power (dBm)	Conducted Power (W)	E.I.R.P. (dBm)	E.I.R.P. Limit (dBm)	Result
5985	14.15	0.0260	17.76	30.00	Pass
6145	13.37	0.0217	16.98	30.00	Pass
6385	13.33	0.0215	16.94	30.00	Pass
6465	13.32	0.0215	16.93	30.00	Pass
6545	13.34	0.0216	16.95	30.00	Pass
6625	14.41	0.0276	18.02	30.00	Pass
6785	13.48	0.0223	17.09	30.00	Pass
6865	13.55	0.0226	17.16	30.00	Pass
6945	13.69	0.0234	17.30	30.00	Pass
7025	13.31	0.0214	16.92	30.00	Pass

Test Mode	IEEE 802.11be (EHT80)_ Ant 2	Tested Date	2024/1/2
-----------	------------------------------	-------------	----------

Test Frequency (MHz)	Conducted Power (dBm)	Conducted Power (W)	E.I.R.P. (dBm)	E.I.R.P. Limit (dBm)	Result
5985	12.98	0.0199	16.59	30.00	Pass
6145	12.68	0.0185	16.29	30.00	Pass
6385	12.28	0.0169	15.89	30.00	Pass
6465	12.49	0.0177	16.10	30.00	Pass
6545	12.60	0.0182	16.21	30.00	Pass
6625	13.30	0.0214	16.91	30.00	Pass
6785	12.50	0.0178	16.11	30.00	Pass
6865	12.36	0.0172	15.97	30.00	Pass
6945	12.41	0.0174	16.02	30.00	Pass
7025	12.48	0.0177	16.09	30.00	Pass

Test Mode	IEEE 802.11be (EHT80)_ Total	Tested Date	2024/1/2
-----------	------------------------------	-------------	----------

Test Frequency (MHz)	Conducted Power (dBm)	Conducted Power (W)	E.I.R.P. (dBm)	E.I.R.P. Limit (dBm)	Result
5985	16.61	0.0459	23.22	30.00	Pass
6145	16.05	0.0403	22.66	30.00	Pass
6385	15.85	0.0384	22.46	30.00	Pass
6465	15.94	0.0392	22.55	30.00	Pass
6545	16.00	0.0398	22.61	30.00	Pass
6625	16.90	0.0490	23.51	30.00	Pass
6785	16.03	0.0401	22.64	30.00	Pass
6865	16.01	0.0399	22.62	30.00	Pass
6945	16.11	0.0408	22.72	30.00	Pass
7025	15.93	0.0391	22.54	30.00	Pass

Test Mode	IEEE 802.11be (EHT160)_ Ant 1	Tested Date	2024/1/2
-----------	-------------------------------	-------------	----------

Test Frequency (MHz)	Conducted Power (dBm)	Conducted Power (W)	E.I.R.P. (dBm)	E.I.R.P. Limit (dBm)	Result
6025	16.63	0.0460	20.24	30.00	Pass
6345	16.26	0.0423	19.87	30.00	Pass
6505	16.12	0.0409	19.73	30.00	Pass
6665	16.28	0.0425	19.89	30.00	Pass
6985	16.19	0.0416	19.80	30.00	Pass

Test Mode	IEEE 802.11be (EHT160)_ Ant 2	Tested Date	2024/1/2
-----------	-------------------------------	-------------	----------

Test Frequency (MHz)	Conducted Power (dBm)	Conducted Power (W)	E.I.R.P. (dBm)	E.I.R.P. Limit (dBm)	Result
6025	15.73	0.0374	19.34	30.00	Pass
6345	15.34	0.0342	18.95	30.00	Pass
6505	15.25	0.0335	18.86	30.00	Pass
6665	15.59	0.0362	19.20	30.00	Pass
6985	15.20	0.0331	18.81	30.00	Pass

Test Mode	IEEE 802.11be (EHT160)_ Total	Tested Date	2024/1/2
-----------	-------------------------------	-------------	----------

Test Frequency (MHz)	Conducted Power (dBm)	Conducted Power (W)	E.I.R.P. (dBm)	E.I.R.P. Limit (dBm)	Result
6025	19.21	0.0834	25.82	30.00	Pass
6345	18.83	0.0765	25.44	30.00	Pass
6505	18.72	0.0744	25.33	30.00	Pass
6665	18.96	0.0787	25.57	30.00	Pass
6985	18.73	0.0747	25.34	30.00	Pass

Test Mode	IEEE 802.11be (EHT320)_ Ant 1	Tested Date	2024/1/2
-----------	-------------------------------	-------------	----------

Test Frequency (MHz)	Conducted Power (dBm)	Conducted Power (W)	E.I.R.P. (dBm)	E.I.R.P. Limit (dBm)	Result
6105	19.36	0.0863	22.97	30.00	Pass
6265	19.06	0.0805	22.67	30.00	Pass
6425	19.41	0.0873	23.02	30.00	Pass
6585	19.63	0.0918	23.24	30.00	Pass
6745	19.40	0.0871	23.01	30.00	Pass
6905	19.39	0.0869	23.00	30.00	Pass

Test Mode	IEEE 802.11be (EHT320)_ Ant 2	Tested Date	2024/1/2
-----------	-------------------------------	-------------	----------

Test Frequency (MHz)	Conducted Power (dBm)	Conducted Power (W)	E.I.R.P. (dBm)	E.I.R.P. Limit (dBm)	Result
6105	18.71	0.0743	22.32	30.00	Pass
6265	18.27	0.0671	21.88	30.00	Pass
6425	18.47	0.0703	22.08	30.00	Pass
6585	18.28	0.0673	21.89	30.00	Pass
6745	18.38	0.0689	21.99	30.00	Pass
6905	17.69	0.0587	21.30	30.00	Pass

Test Mode	IEEE 802.11be (EHT320)_ Total	Tested Date	2024/1/2
-----------	-------------------------------	-------------	----------

Test Frequency (MHz)	Conducted Power (dBm)	Conducted Power (W)	E.I.R.P. (dBm)	E.I.R.P. Limit (dBm)	Result
6105	22.06	0.1606	28.67	30.00	Pass
6265	21.69	0.1477	28.30	30.00	Pass
6425	21.98	0.1576	28.59	30.00	Pass
6585	22.02	0.1591	28.63	30.00	Pass
6745	21.93	0.1560	28.54	30.00	Pass
6905	21.63	0.1456	28.24	30.00	Pass

## **APPENDIX B MAXIMUM TRANSMITTER CHANNEL BANDWIDTH**

Test Mode	IEEE 802.11ax (HE20)_ Ant 1
-----------	-----------------------------

Test Frequency (MHz)	26 dB Bandwidth (MHz)	99 % Occupied Bandwidth (MHz)	Limit (MHz)	Result
5955	22.58	19.18	320	Pass
6175	22.85	19.20	320	Pass
6415	23.01	19.18	320	Pass

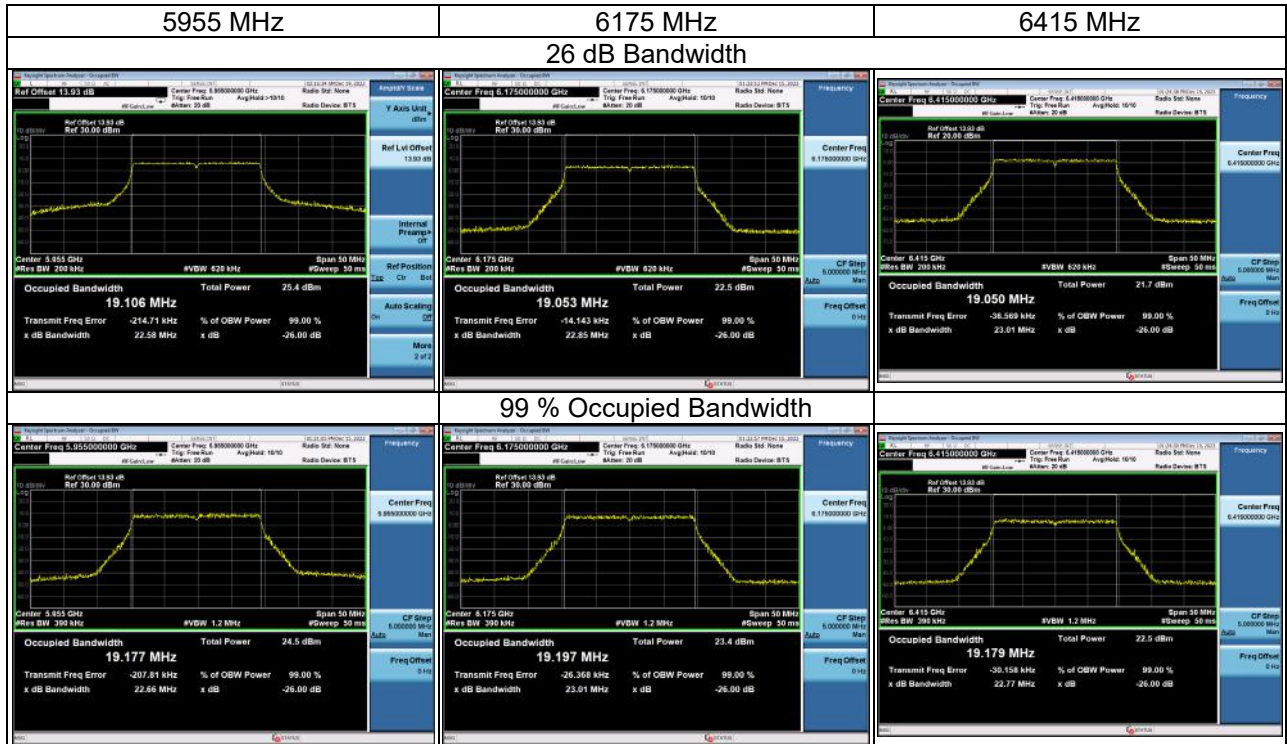

Test Frequency (MHz)	26 dB Bandwidth (MHz)	99 % Occupied Bandwidth (MHz)	Limit (MHz)	Result
6435	22.67	19.18	320	Pass
6475	22.11	19.19	320	Pass
6515	22.36	19.15	320	Pass

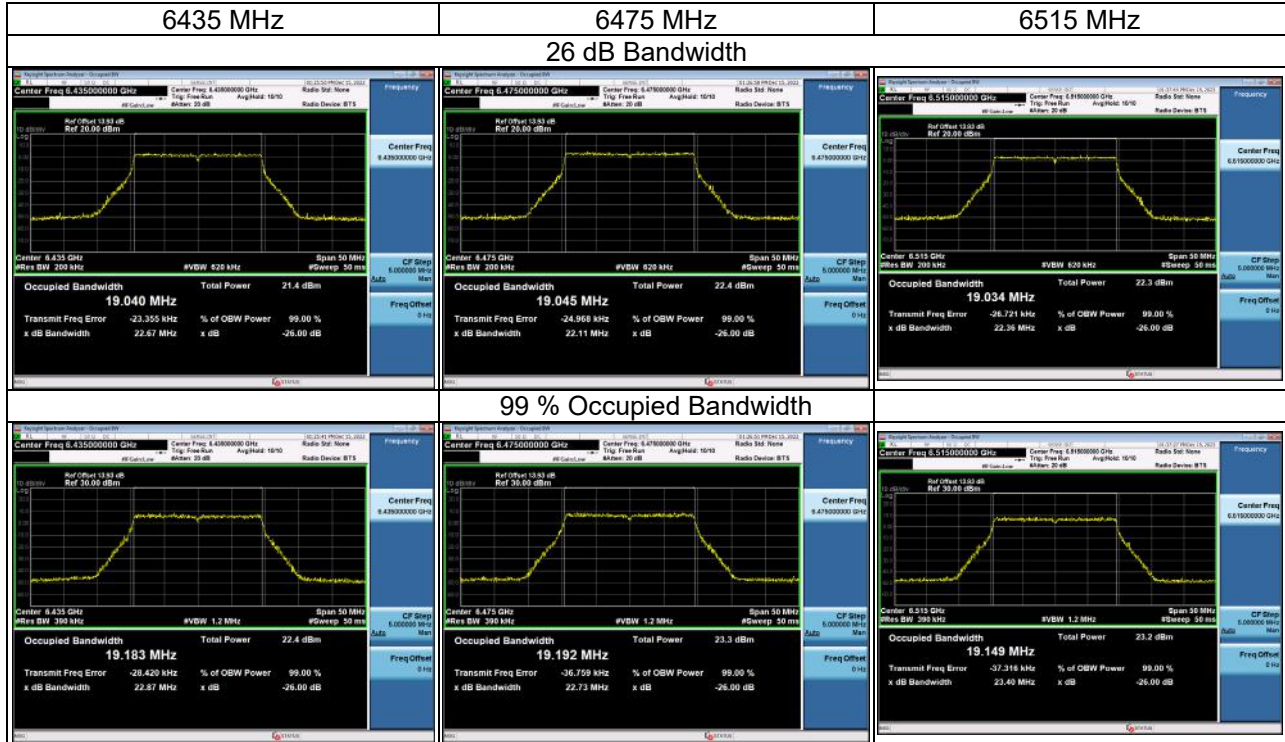

Test Frequency (MHz)	26 dB Bandwidth (MHz)	99 % Occupied Bandwidth (MHz)	Limit (MHz)	Result
6535	22.74	19.19	320	Pass
6695	22.59	19.18	320	Pass
6855	22.80	19.16	320	Pass

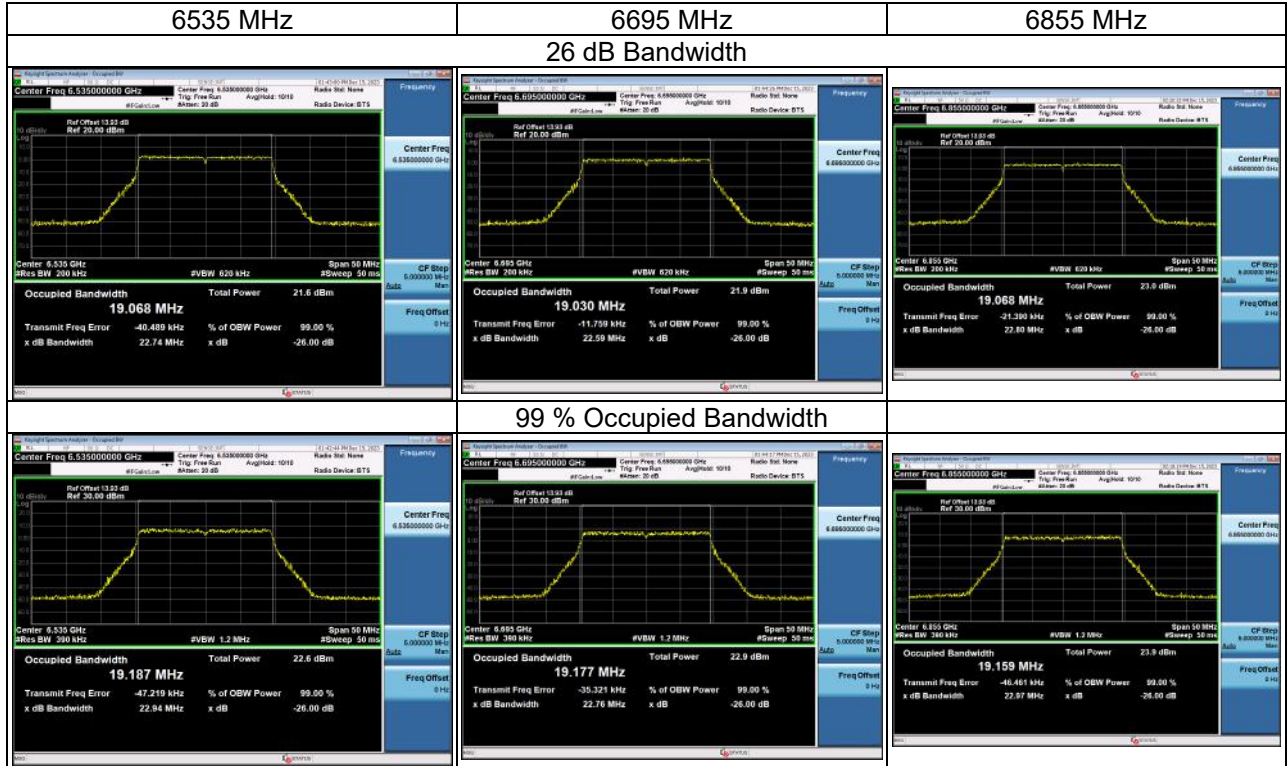

Test Frequency (MHz)	26 dB Bandwidth (MHz)	99 % Occupied Bandwidth (MHz)	Limit (MHz)	Result
6875	22.49	19.20	320	Pass
6995	22.39	19.18	320	Pass
7095	22.55	19.15	320	Pass
7115	22.89	19.31	320	Pass

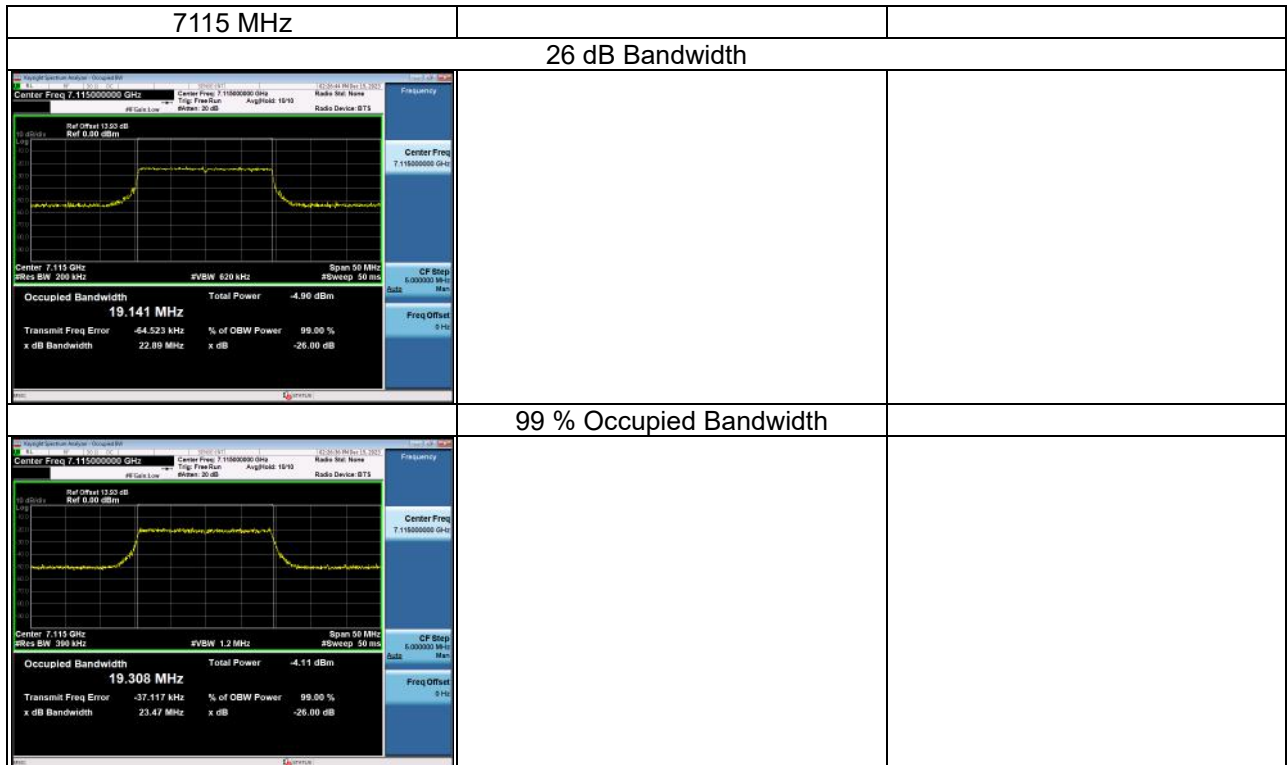
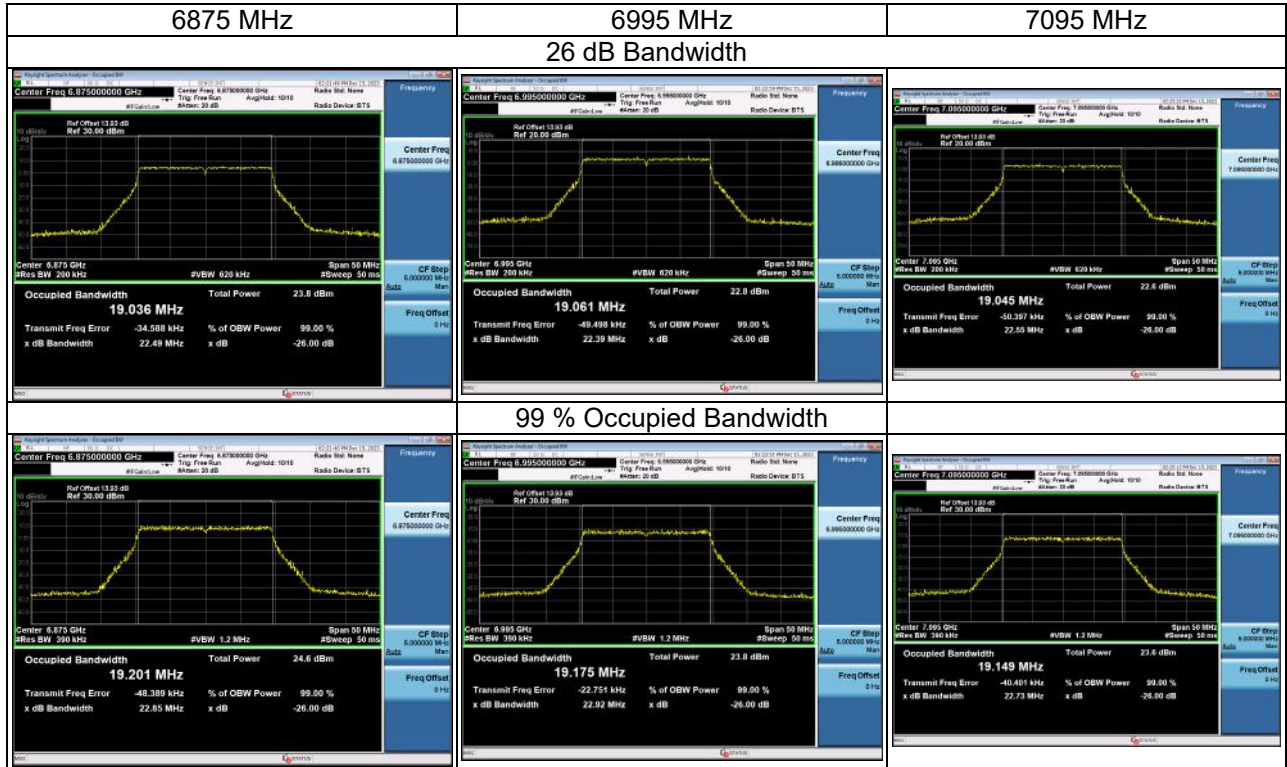



Test Mode	IEEE 802.11ax (HE40)_ Ant 1
-----------	-----------------------------

Test Frequency (MHz)	26 dB Bandwidth (MHz)	99 % Occupied Bandwidth (MHz)	Limit (MHz)	Result
5965	44.17	38.36	320	Pass
6165	43.83	38.32	320	Pass
6405	43.65	38.21	320	Pass

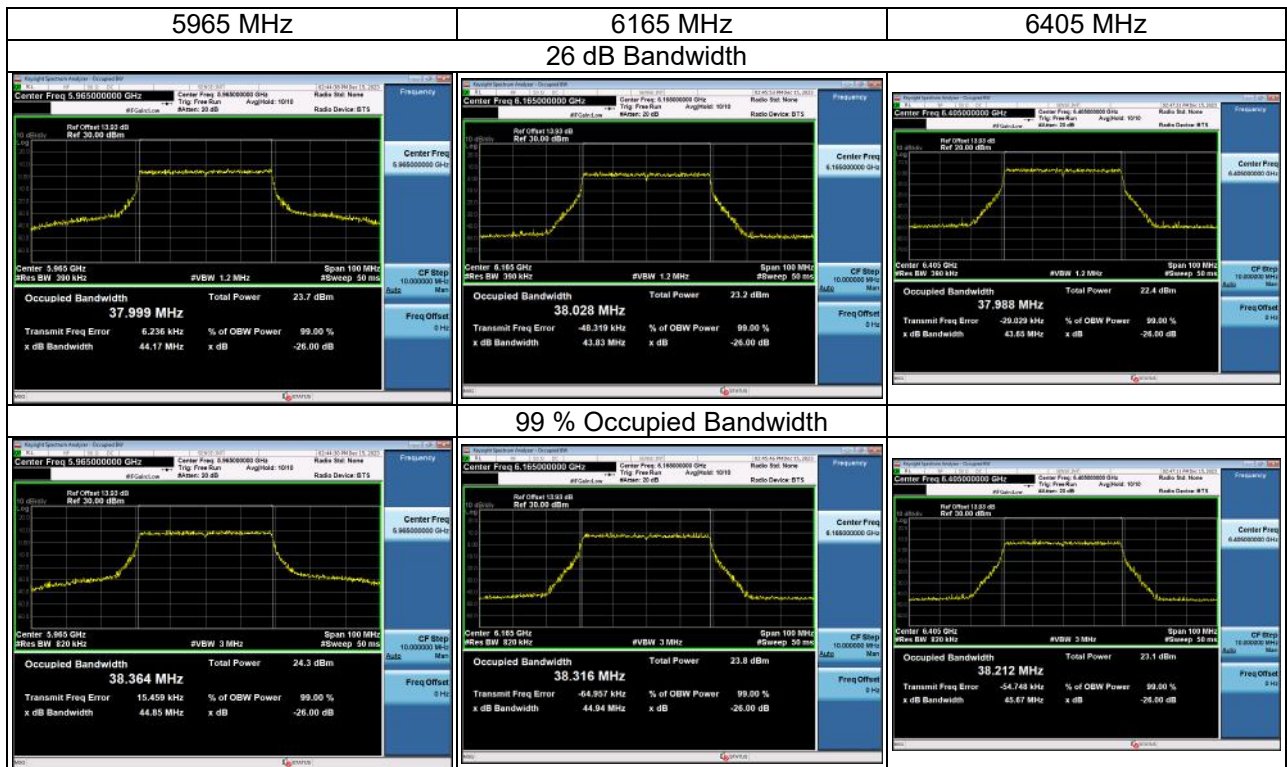

Test Frequency (MHz)	26 dB Bandwidth (MHz)	99 % Occupied Bandwidth (MHz)	Limit (MHz)	Result
6445	43.32	38.27	320	Pass
6485	43.36	38.23	320	Pass

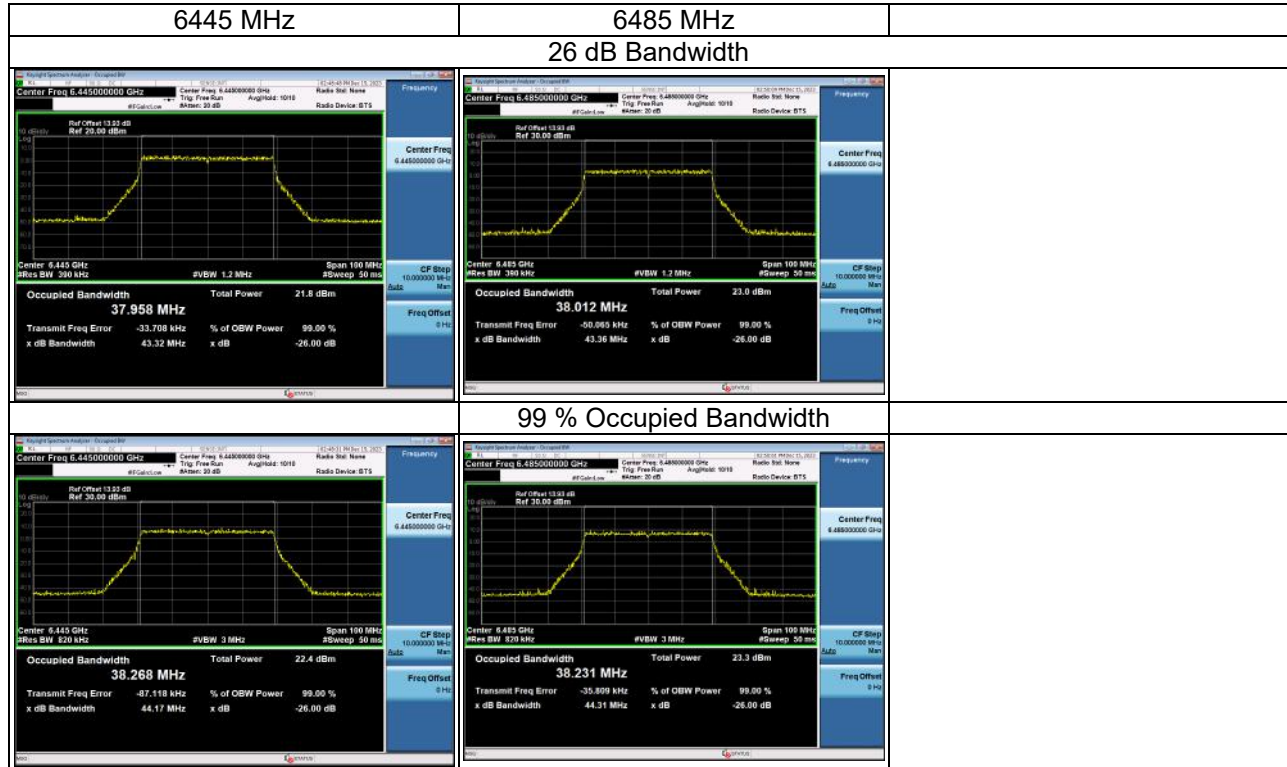

Test Frequency (MHz)	26 dB Bandwidth (MHz)	99 % Occupied Bandwidth (MHz)	Limit (MHz)	Result
6525	42.85	38.20	320	Pass
6685	44.16	38.27	320	Pass
6845	43.32	38.34	320	Pass

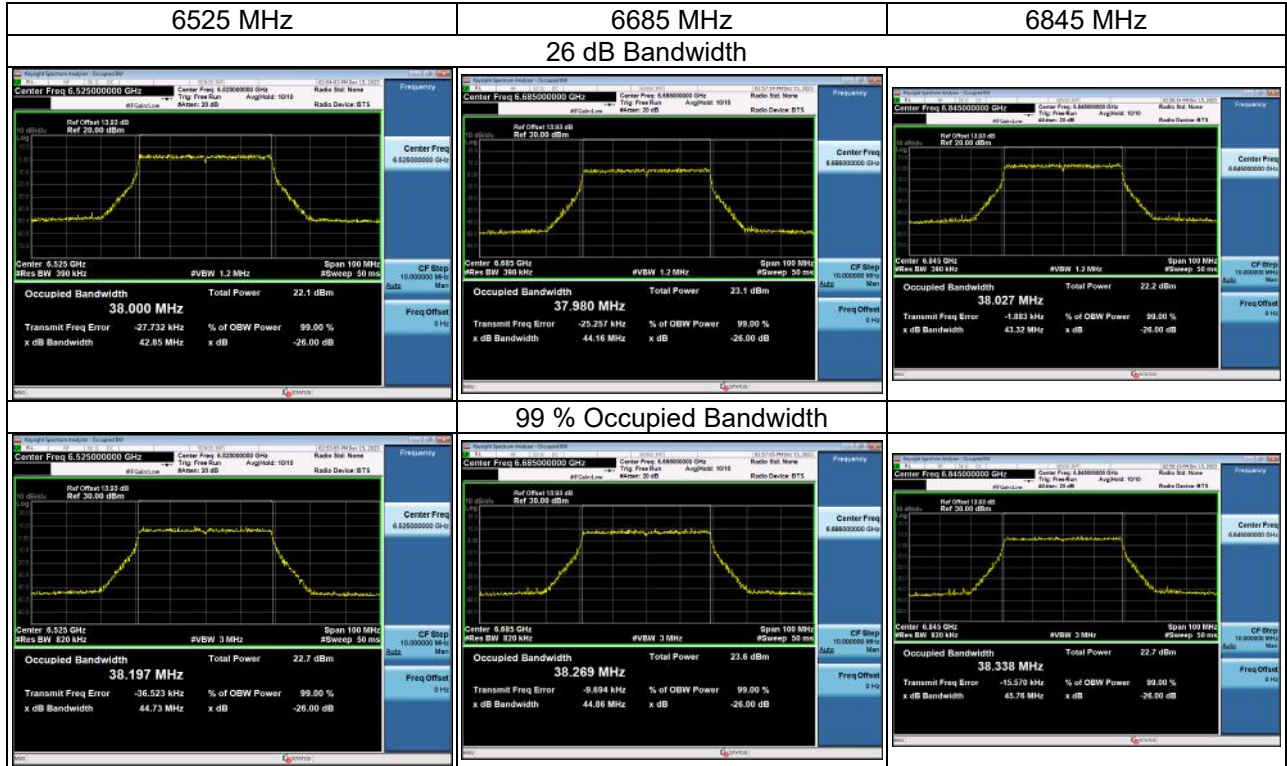

Test Frequency (MHz)	26 dB Bandwidth (MHz)	99 % Occupied Bandwidth (MHz)	Limit (MHz)	Result
6885	43.43	38.28	320	Pass
7085	43.84	38.29	320	Pass

