



PRODUCT INSTALL GUIDE

M4XX SERIES



Reference No:	10001
Version:	V1.9.9
Date of Version:	03/11/22
Author:	Christian Stähle
Approved by:	eLearning Team
Translated by:	-
Classification:	MCF Internal

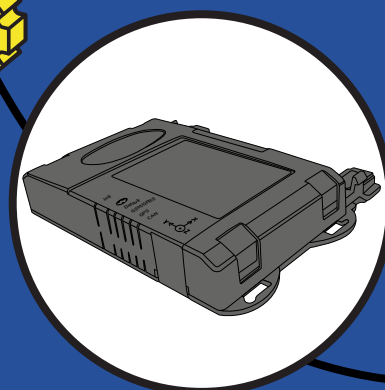

1. TABLE OF CONTENTS

1.	TABLE OF CONTENTS	2
2.	IMPORTANT NOTES	4
3.	REQUIRED TOOLS AND CONSUMABLES	5
4.	M4XX VERSIONS	6
5.	PARTS	7
6.	WIRING DIAGRAM	8
	M40X	8
	M41X	9
	VEHICLE SPECIFICS	10
7.	POWER SUPPLY	10
	+POWER	10
	+IGNITION	10
	GROUND	10
	POWER I/O CONNECTOR	10
8.	IGNITION	11
9.	SOLDERING METHOD	12
10.	CRIMPING TERMINAL METHOD	12
11.	ANTENNAS	13
	INTERNAL ANTENNAS (M41X)	13
	GSM & GSM/LTE ANTENNA (M40X)	15
	GPS ANTENNA (M40X)	15
	GSM, GSM/LTE & GPS POSITIONS (M40X)	16
	DUAL ANTENNA (GSM/GPS) (M400/3)	16
12.	CAN (OPTIONAL)	17
13.	HMI (OPTIONAL)	18
	INSTALLATION	18
	POSITION	18
	FEATURES	18
14.	CABLE ROUTING	19
	LOOMING	19
	ROUTING	19
15.	UNIT MOUNTING	20
	SECURING THE UNIT	20
	ORIENTATION	20
	POSITIONING	20
	M41X	20

1. TABLE OF CONTENTS

16.	I/O PROTECTION AND WARRANTY/TAMPER SEALS	21
	ATTACHING THE I/O PROTECTION	21
	WARRANTY/TAMPER STICKERS	21
17.	COMMISSIONING	22
	MASTER MANAGER MOBILE	22
	VEHICLE INFORMATION	22
	CONFIGURATION	22
	INSTALL INFORMATION	22
	VALIDATION	22
	SPECIALIST SOLUTIONS	22
18.	INPUT/OUTPUT (OPTIONAL)	23
	INPUT COMPATIBILITY	23
19.	TACHOFRESH (OPTIONAL)	24
	TACHOFRESH	24
	COMPATIBILITY	24
	WIRING	24
20.	GRITTERS (OPTIONAL)	25
	COMPATIBILITY	25
	WIRING	25
21.	TEMPERATURE (OPTIONAL)	26
	COMPATIBILITY	26
	WIRED PROBES WIRING	26
	WIRED PROBES INSTALLATION	26
	WIRELESS TEMPERATURE	26
22.	DEVICE OVERVIEW	27
	LED SEQUENCE TROUBLESHOOTING	27
	UNIT ICONOGRAPHY	27
23.	CERTIFICATION INFORMATION	28
	USA FCC - M405 / M404 + HMI + SCN4	28
	CANADA ISED - M405 / M404 + HMI + SCN4	28
	SOUTH AFRICA ICASA - M405 / M404 + HMI + SCN4	28
	AUSTRALIA AND NEW ZEALAND RCM - M405 + HMI + SCN4	28
24.	CONTACTS	29
25.	VERSION HISTORY	29
	FROM V 1.9.9 ONWARDS	29



2. IMPORTANT NOTES

NOTE! Read carefully this contains important information.

- Before you begin installing and commissioning this equipment please ensure that you have read this manual thoroughly referring to any supplementary information provided for the OBU as required.
- Failure to comply with the following Warnings, Approval and Safety information may invalidate the warranty, certification or type approval of this product.
- In order to maximise any insurance discounts that may apply it is essential that all installation and service work is carried out in regulations of the country. It is strongly recommended that the OBU (On Board Unit) is installed and commissioned by suitably trained and qualified personnel, accredited and registered by the Vehicle Systems Installation Board.
- Before working on any connectors or wires, turn the ignition OFF and wait 5 minutes, for sleep mode to kick in.
- Never turn the ignition ON if a connector is disconnected.
- A battery conditioning test must be completed during the pre-installation vehicle checks. If the battery is defective, or requires recharging you must inform the customer and record this in your report before proceeding with the installation.
- Never operate the OBU without the correct antennas, or suitable artificial loads, connected.
- To minimise interference 20 cm (7.87 inch) must be maintained between the GSM antenna and the GPS antenna, all persons, and electronic components.
- The user of all or part of the equipment is warned that any changes or modifications not expressly approved by Masternaut may prohibit its use.
- With the exception of specific installations with properly rated parts, this equipment should not be operated in hazardous environments e.g; areas with flammable vapours or explosive materials.
- This equipment should not be operated within aircrafts or in close proximity to medical equipment.
- This equipment may only be located in a position where it cannot interfere with the normal operation of the vehicle or present a hazard to the driver or passengers. Care must also be taken when the routing the cables so that the insulation does not become worn or damaged. The cables must not be in contact with the mechanical parts of the vehicle (e.g. steering, pedals, etc.).
- Under no circumstances may any part of the OBU be installed inside the engine compartment.
- Always use special tools when disassembling the dash board and a multimeter to check all connections.
- Warranty/tamper seals must be used.
- Tidy the vehicle after you, do not leave any bits of wire or pieces of tape behind.

3. REQUIRED TOOLS AND CONSUMABLES



Torch



Torx screwdrivers

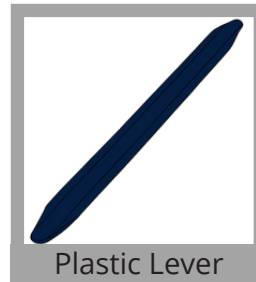

Plastic Lever

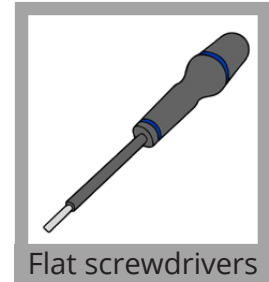

Flat screwdrivers



Multimeter



Plastic Cutter



Wire Cutter



Wire Stripper



Crimping Tool



Heat Gun (Gas)



Round File



Drill



Ratchet



Soldering Iron



Solder Wire



Ring Terminals



Reinforced Tape



Cable Ties
(different sizes)



Amalgamating
Tape



Heatshrink

4. M4XX VERSIONS

	M400 / M403	M404 / M405	M410	M414 / M415
External Antennas	✓	✓	✗	✗
Internal Antennas	✗	✗	✓	✓
GSM	✓	✓	✓	✓
LTE	✗	✓	✗	✓

NOTE: For instructions that **do not** refer to the full M4xx series will be referred to as follows:

M40x = M400, M403, M404 & M405

M400/3 = M400 & M403

M41x = M410, M414 & M415

5. PARTS

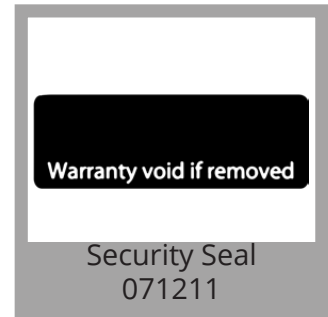
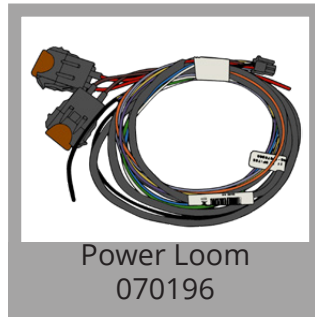
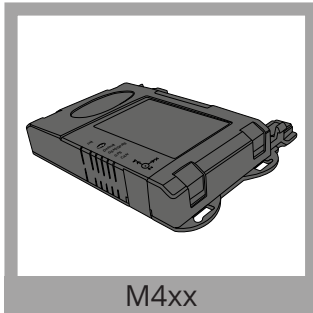

Tachofresh & Gritter Parts

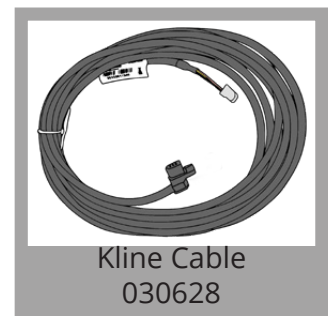
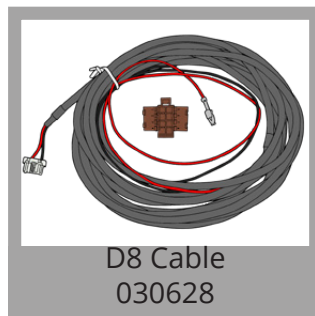

6. WIRING DIAGRAM

M40X

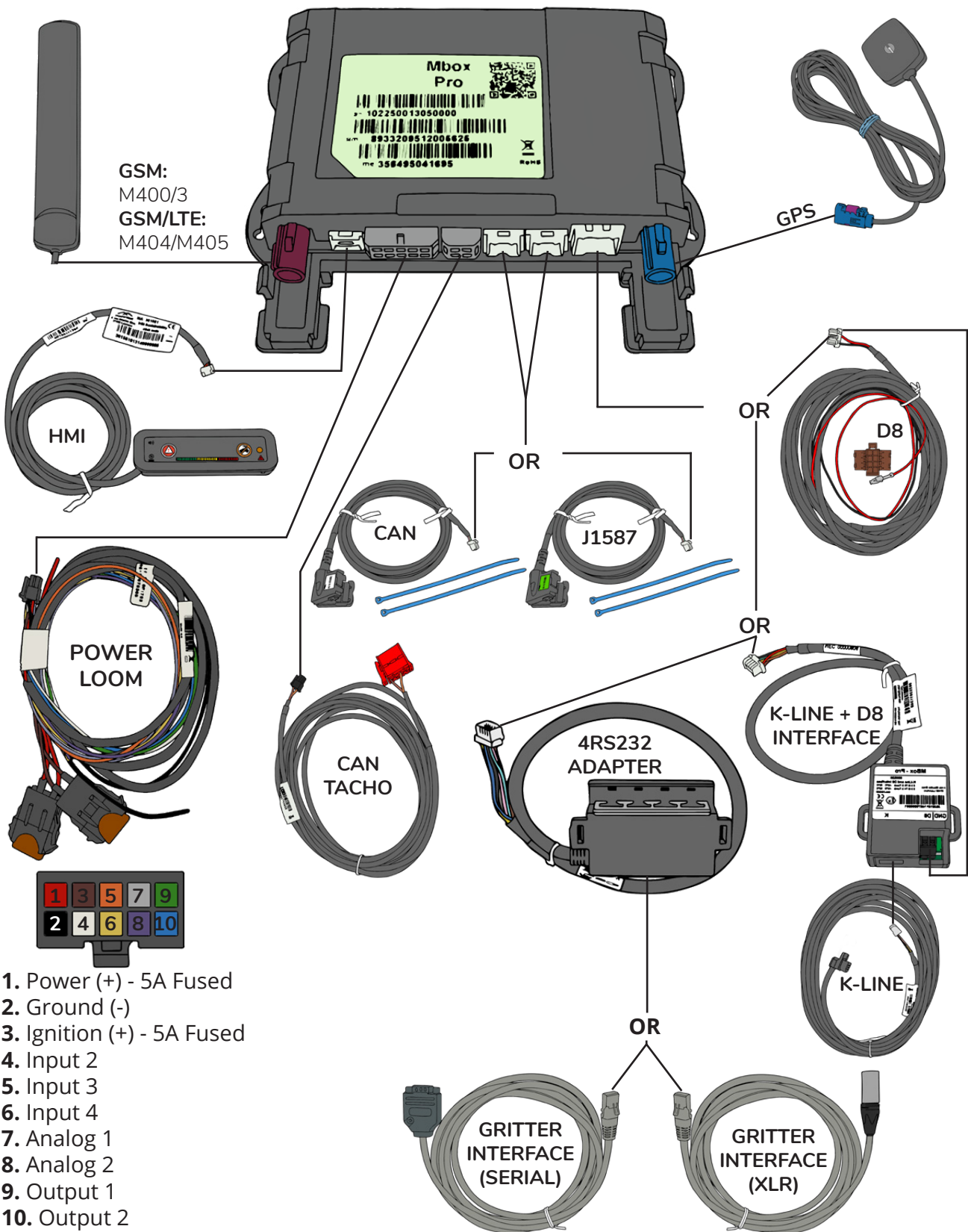

1. Power (+) - 5A Fused
2. Ground (-)
3. Ignition (+) - 5A Fused
4. Input 2
5. Input 3
6. Input 4
7. Analog 1
8. Analog 2
9. Output 1
10. Output 2

7. WIRING DIAGRAM

M41X

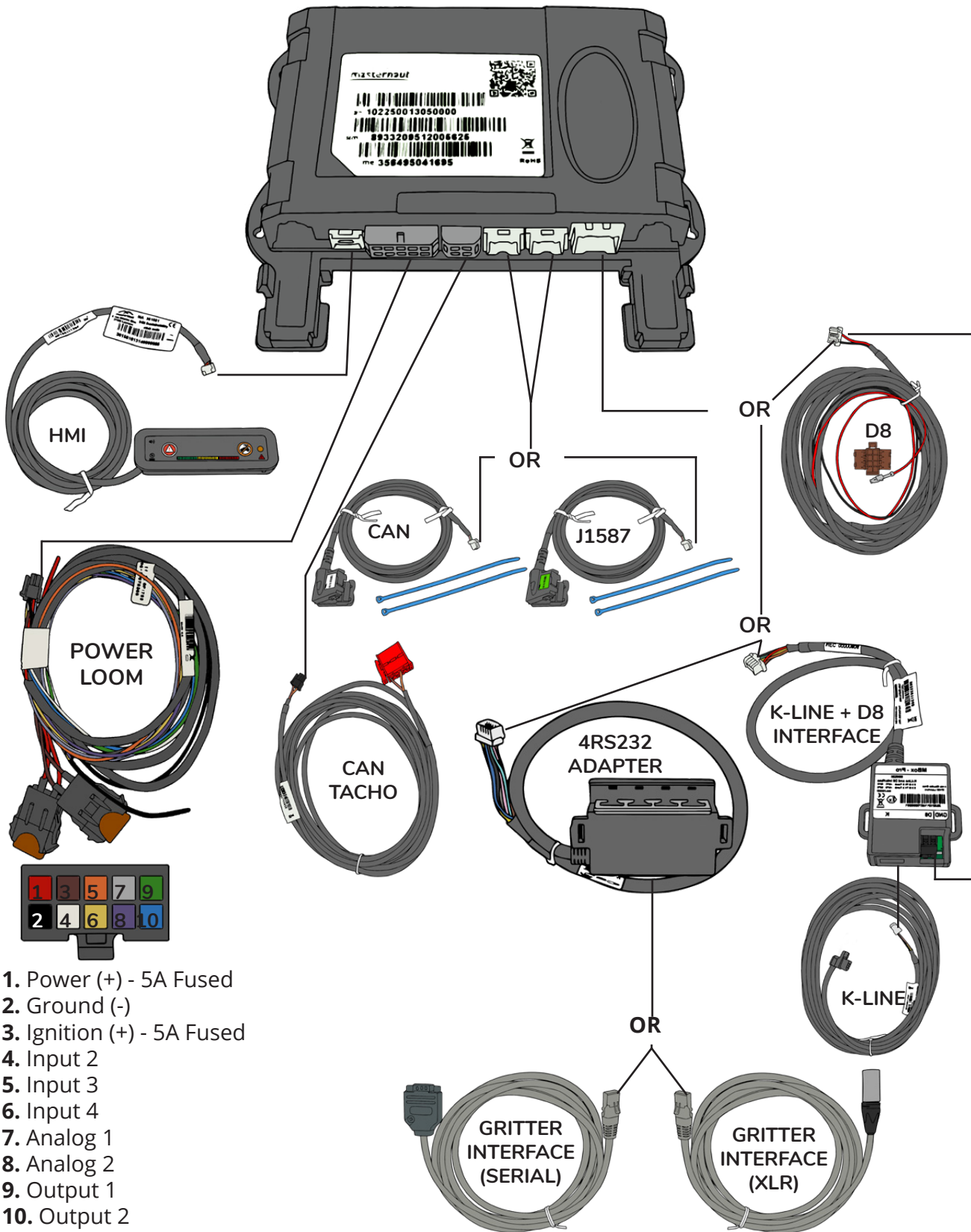

1. Power (+) - 5A Fused
2. Ground (-)
3. Ignition (+) - 5A Fused
4. Input 2
5. Input 3
6. Input 4
7. Analog 1
8. Analog 2
9. Output 1
10. Output 2

7. POWER SUPPLY

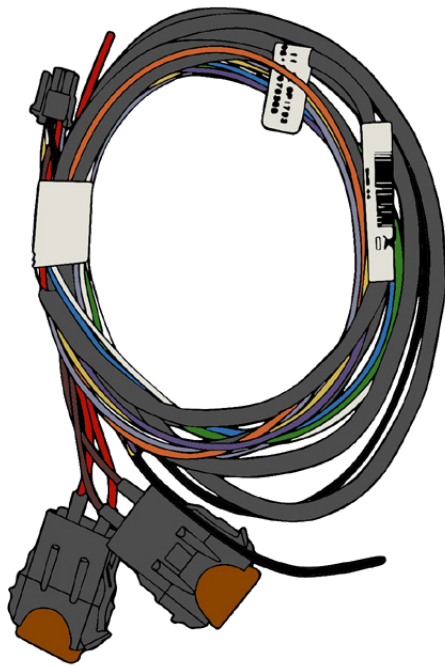

+POWER

Permanent power supply feed (12/24V-DC)

- Provides Power to the system. Must be fitted after circuit breaker (if available).

+IGNITION

Ignition Feed (12/24 V-DC)

- Must be connected to the ignition (2nd stage, still ON when engine is running) and NEVER to the true engine idling feed (which is only ON when engine is running).

(See page 10)

GROUND

- Must be connected directly to the chassis or a ground terminal.

NEVER use a self-tapping screw for a ground connection.

POWER I/O CONNECTOR



Main Loom

Power (+)	-	RED
Ground (-)	-	BLACK
Ignition(+)	-	BROWN

Input/Output (see page 22)

Input 2	-	WHITE
Input 3	-	ORANGE
Input	-	YELLOW
Analog 1	-	GREY
Analog 2	-	PURPLE
Output 1	-	GREEN
Output 2	-	BLUE

VEHICLE SPECIFICS

Always refer and follow MICHELIN Connected Fleet's recommended Power (+), Ignition (+), and Ground (-) connection points for the vehicle you are working on.

The recommended connection points are available:

- In the Vehicle guides, available on your job on Salesforce ([Salesforce Guide](#))
- On the Master Manager Mobile (MMO) Install page ([MMO guide](#))
- In the CAN-database, available through MMO ([Link to MMO](#))

NOTE:

ALWAYS double check your connections with a multimeter as colours or wiring may change.

ALWAYS position the 5A fuses on the fused connections, power and ignition, as near to the connection point as possible (do not extend the fuse wires).

ALWAYS connect the power supply to the feed first and then to the OBU, to avoid electrical primers.

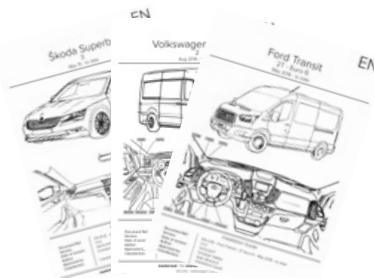
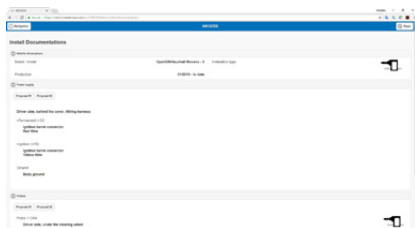

8. IGNITION

It is important to differentiate between the first (accessories) stage and second (ignition) stage.

You have to make sure that you connect the ignition wire to a second (ignition) stage ignition feed. If connected to the first (accessories) stage the data recorded by the M4xx will be wrong, for example idling.

The ignition feed must also be live when a Stop & Start occurs (engine off at traffic lights). The feed does not have to be live while cranking but it is good practice if it is.

Turn key to 1st stage* 	Instrument Cluster Off 	0 Vdc on multimeter
Turn key to 2nd stage 	Instrument Cluster On 	12 Vdc on multimeter
Crank the engine 	Instrument Cluster On 	12 Vdc on multimeter**
Stop the engine 	Instrument Cluster Off 	0 Vdc on multimeter

NOTE:

*Some vehicles do not have an accessories stage and the first position of the barrel is ignition.

**Sometimes the voltage will fall to 0Vdc while the engine is cranking and then returns to 12-14Vdc.

9. SOLDERING METHOD

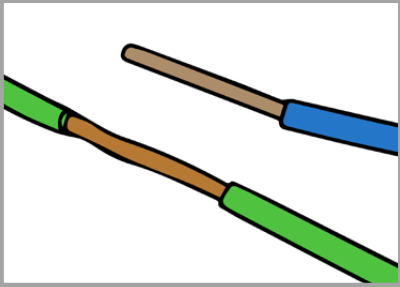
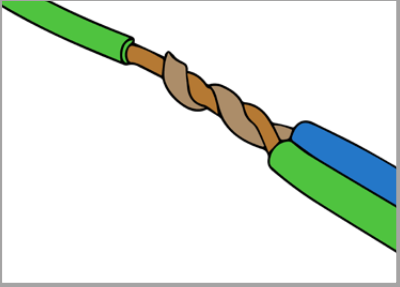
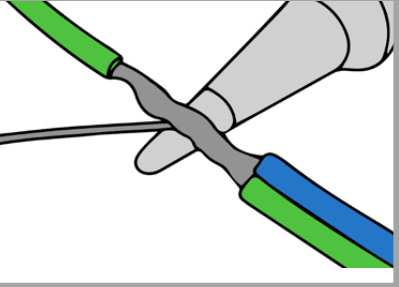
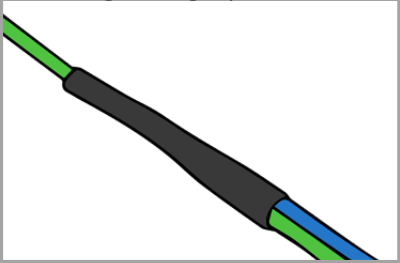
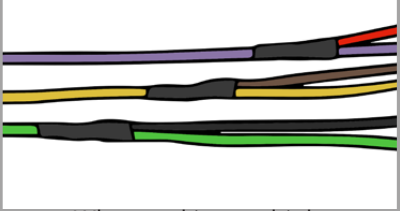
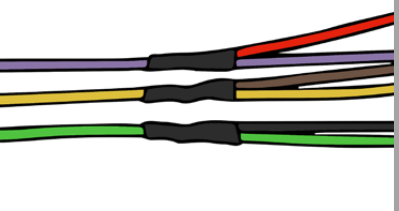
<p>1 Strip about 10mm of the insulation.</p> 	<p>2 Twist the wires together.</p> 	<p>3 Solder the wires together.</p> 
<p>4 Insulate and waterproof the connection with electrical and amalgamiting tape/heat shrink.</p> 	<p>Best practise.</p>  <p>When making multiple connections on the same loom it is good practise to space out the connection points.</p>	<p>Bad practise.</p> 

10. CRIMPING TERMINAL METHOD



Prior to cutting and crimping any cables you **MUST** make sure that the ignition is turned off, also double check the wire with a multimeter.

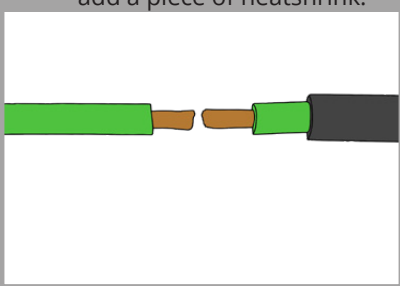
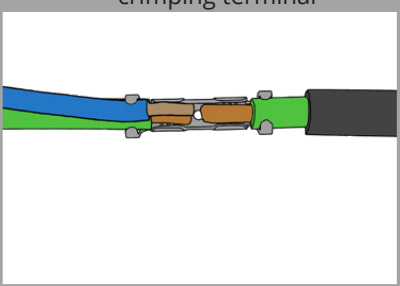
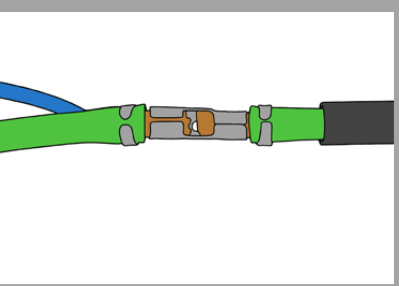
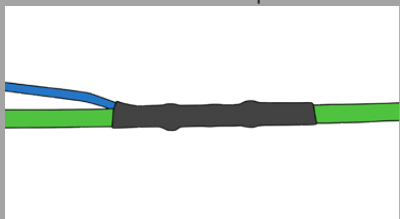
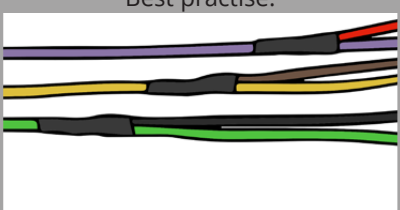
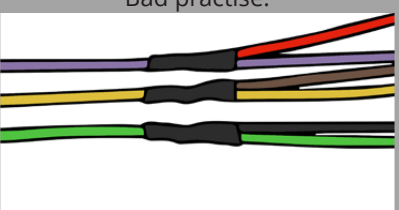

<p>1 Cut and strip the feed wire and add a piece of heatshrink.</p> 	<p>2 Line up the wires in the crimping terminal</p> 	<p>3 Crimp the wires together</p> 
<p>4 Heat the heatshrink and wrap with insulating tape to insulate and waterproof the connection point.</p> 	<p>Best practise.</p>  <p>When making multiple connections on the same loom it is good practise to space out the connection points.</p>	<p>Bad practise.</p> 

11. ANTENNAS

INTERNAL ANTENNAS (M41X)

GSM ANTENNA

The GSM antenna in the M41x is located internally by the connectors on the side with the label.

GPS ANTENNA

The GPS antenna in the M41x is located internally by the LEDs on the side with the label.

INTERFERENCE

When possible, to reduce interference, the M41x should be placed atleast 15 inches/40cm) from any electrical equipment.

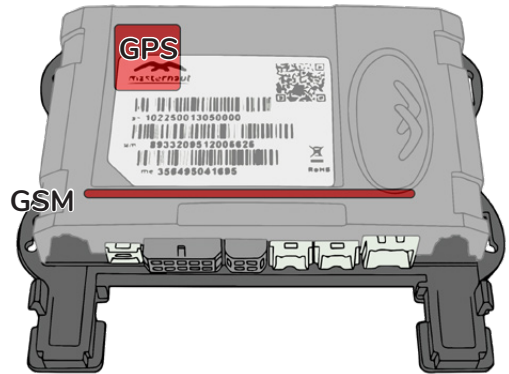

POSITIONING GUIDELINES

The M41x, the OBU must **NEVER** be mounted behind or beneath any metal structures. This will obstruct the antennas.

[Click here for the M41x recommended positions appendix.](#)

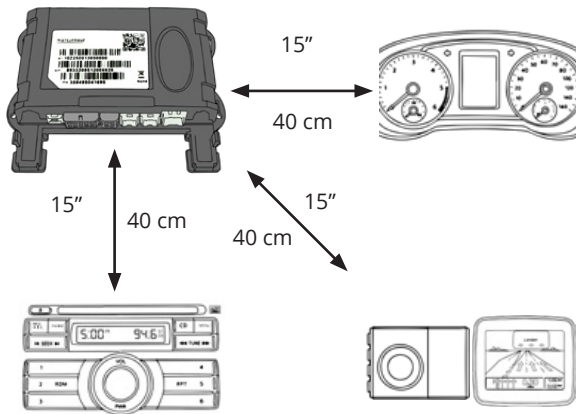

The side with the label should always face up or towards the inside of the vehicle. See below illustration.

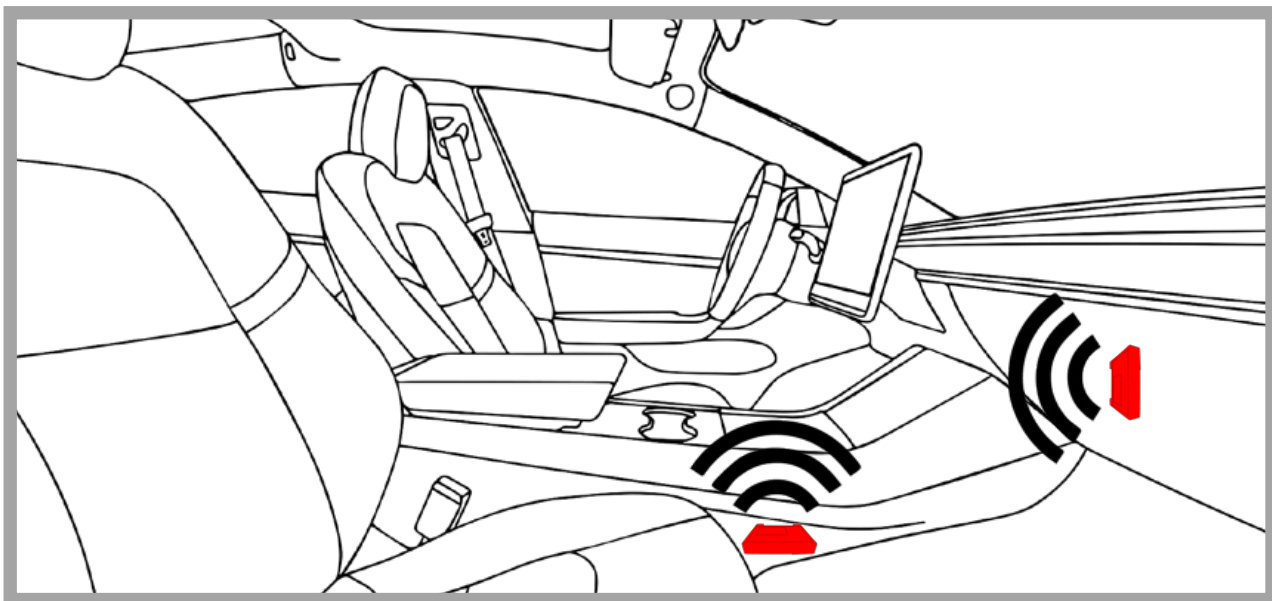

12. ANTENNAS

POSITIONING EXAMPLES

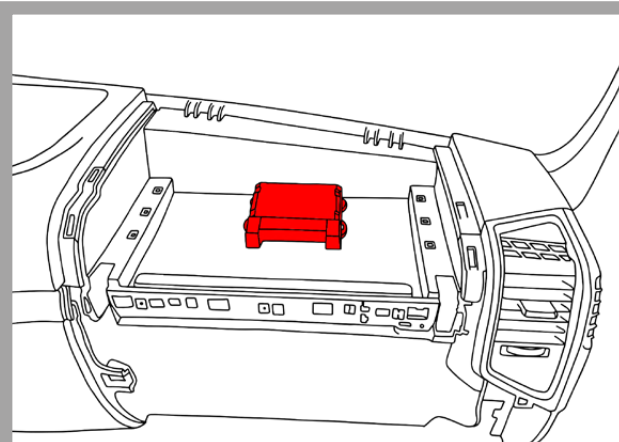

Mercedes-Benz Trucks Actros & Arocs (MP4)

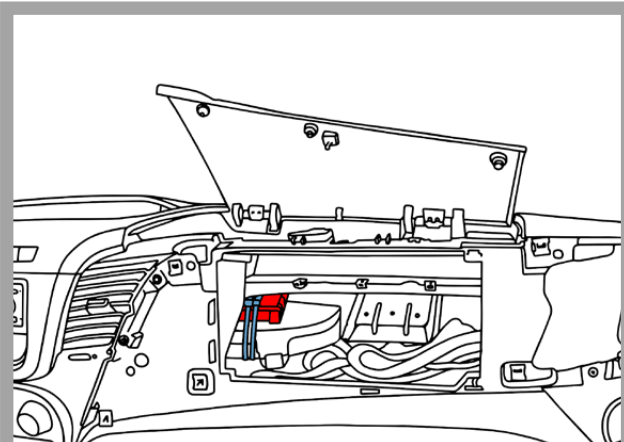

Iveco Daily (Euro 6)

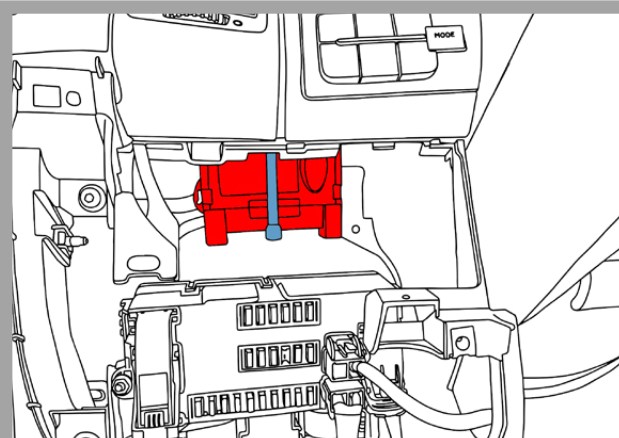

Citroen Jumper/Relay & Fiat Ducato & Peugeot Boxer

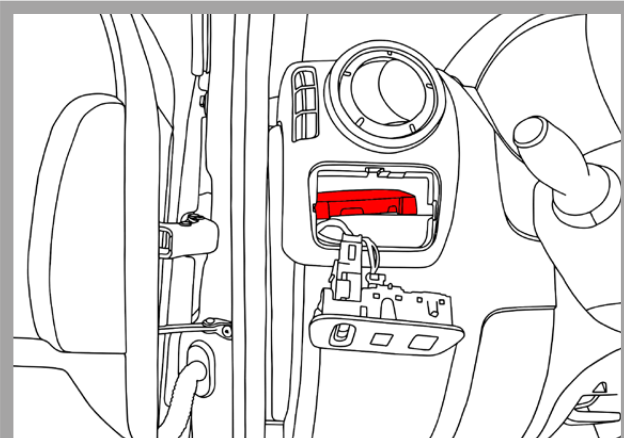

Renault Master 3 & Vauxhall/Opel Movano 2

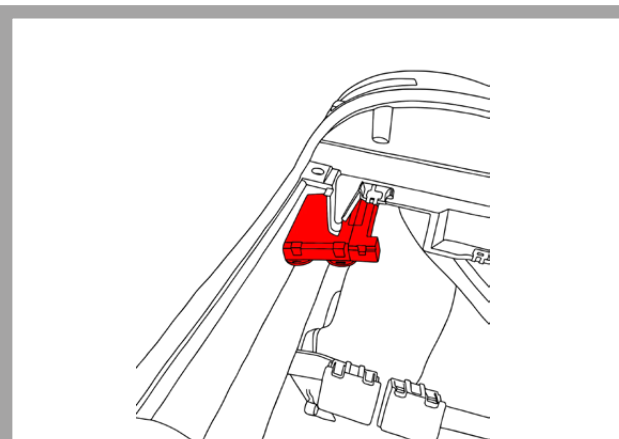

Scania R (Passenger side)

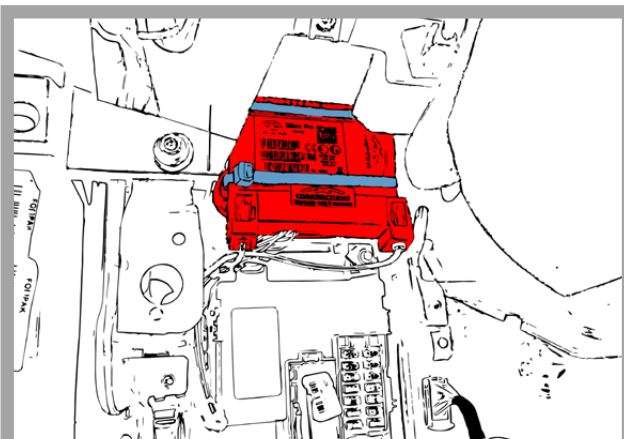

Fiat Doblo (2)

NOTE: The M41x must be installed behind the dash trim of the vehicle and not accessible to the end user (driver).

12. ANTENNAS

GSM & GSM/LTE ANTENNA (M40X)

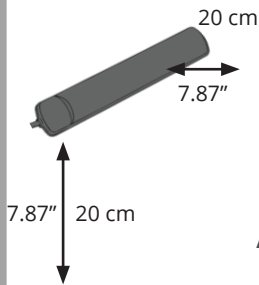

INTERFERENCE

To reduce interference the GSM & GSM/LTE antennas **MUST** be placed at least 7.87 inches (20 cm) from the GPS antenna and any electrical equipment. It must also be placed at least 1.2 inches (3 cm) from any metal in the vehicle.

POSITIONING AND MOUNTING

The GSM & GSM/LTE antennas is installed **covertly**, but it can also be installed **overtly** on the windscreen. See examples § [“GSM, GSM/LTE & GPS positions \(M40x\)”](#) on page 16.

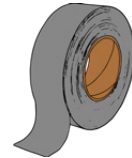

When installing the GSM & GSM/LTE antennas **covertly** you fit it behind a panel or the dash, see the vehicle specific guide for positions. Fix the antenna in position with the reinforced tape.

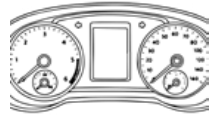

If you are installing the GSM & GSM/LTE antennas **overtly** on a thermal windscreen, with a dotted area, make sure you are fitting it on the non-thermal, dotted, area. See § [“GSM, GSM/LTE & GPS positions \(M40x\)”](#) on page 16. If you are installing it **overtly** on a classic windscreen fit it behind the rear view mirror in one of the bottom corners. See § [“GSM, GSM/LTE & GPS positions \(M40x\)”](#) on page 16.



GPS ANTENNA (M40X)

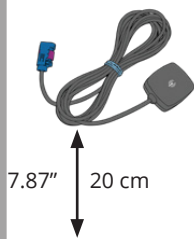

INTERFERENCE

To reduce interference the GPS antenna **MUST** be placed at least 7.87 inches (20 cm) from the GSM antenna.

POSITIONING

The GPS antenna is fitted under the dash or on the a-pillar, with a clear line of sight to the sky. See § [“GSM, GSM/LTE & GPS positions \(M40x\)”](#) on page 16 for examples.

The MICHELIN Connected Fleet logo on the GPS antenna must face the sky, see below. There is also an arrow on the side indicating the way it must face.

There can be no metal obstructing the line of sight of the GPS antenna.

MOUNTING

Use the included double sided tape and a piece of reinforced tape on top to fix the antenna in position. The antenna also has a magnet to hold it in place if you are fitting it to metal.

The side with the antenna symbol must be facing the sky.

