

SLAM2000

HANDHELD LASER SCANNER

Product Manual

202312

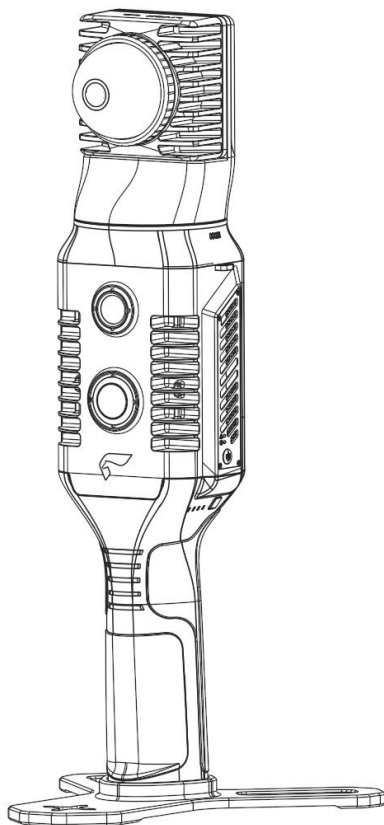

Shenzhen Feima Robotics Co., Ltd.

Catalog

Catalog.....	3
(English)	6
Disclaimer	6
Configuration list.....	8
SLAM2000 Workbox Packing List.....	8
Product Introduction.....	9
Product Overview	9
Product Features	9
Software Package.....	10
System Parameters	13
Product Use.....	15
SLAM2000 Usage Process	15
Device Assembly	16
Equipment Recovery.....	21
Indicator Description	22
Charging Method	25
Device Power Supply	26
Data Storage	29
Product Activation	30
Data Collection	30
Device Power On	30
Start Collection.....	30
GCP Collection.....	31
Stop Collection.....	32
Equipment Shutdown	32
Data Checking	32
Problem Analysis	32
SLAM GO Operating Instructions	33
Overview.....	33
SLAM GO Registration and Login.....	36

Register Feima account.....	36
Login Account.....	37
Personal Center	38
Change Login Password.....	38
Activation Request.....	39
Language Setting	39
About SLAM GO.....	40
Software Upgrade	40
Exit Login.....	40
APP Home Page	41
Device Binding.....	42
Device Activation.....	43
Device Connection Status	46
Device Status – Successful Connection	46
Device Status – Initializing	46
Device Status – Standby.....	46
Device Status – Connection Failure.....	47
Device Status – Not in Communication Range.....	47
Standby Test Shooting	48
Device Working Interface.....	49
In Work – Real-time 3D Data Display.....	50
In Work – View SLAM2000 Status Information	50
Control Point Acquisition	51
Settings	51
Modify the Device Name.....	52
Camera Parameters Settings	52
Wi-Fi Settings.....	53
Format SSD	53
Firmware Update	54
Delete Device.....	56
Project Management.....	57
Project List.....	57

Project Synchronization	58
Project Search	59
Modify the Project Name	60
Project Deletion	60
Diagnosis and Feedback	61
Feedback.....	61
Log File Upload/Export Log.....	62
Data Collection Guidance.....	63
Site Inspection	63
Indoor Environment.....	63
Closed Loop.....	65
U-shaped Closed Route	65
Single Closed O-shape Route	65
Multi-closed O-shaped Route	65
Typical Environmental Data Collection Considerations	66
Precautions When Passing through the Door.....	66
Precautions When Cornering	66
Precautions for Large-area Data Acquisition.....	67
Caution	68
Cleaning & Maintenance.....	69
Storage Requirement.....	69
Contact Us	70

(English)

Disclaimer

Thank you for purchasing the SLAM2000 product. The content mentioned in this document is related to your safety and legal rights and responsibilities. Before using this product, please read this article carefully to ensure that the product is properly set up. Failure to follow the instructions and warnings in this document may result in injury to you and those around you, and damage to the SLAM200 or other surrounding items. The final interpretation right of this document and all related documents of SLAM2000 belongs to Shenzhen Feima Robotics Co., Ltd. (hereinafter referred to as Feima). Subject to update without notice.

Once you use this product, it is deemed that you have carefully read the disclaimer and warning, and understand, recognize, and accept all the terms and contents of this statement. You undertake to take full responsibility for the use of this product and the possible consequences. You undertake to use this product only for legitimate purposes and agree to these terms and any relevant regulations, policies, and guidelines formulated by Feima.

Except as provided by the current laws and regulations of China, Feima shall not be liable for any loss, injury, or any legal liability arising from the direct or indirect use of the product or this information. Users should follow all safety guidelines including but not limited to those mentioned in this document.

Feima reserves the right to change this product manual and product status. For the latest version of the product manual, please go to www.feimarobotics.com/en official website to download it.



This symbol is a trademark of Shenzhen Feima Robotics Co., Ltd. and its affiliates. Product names, brands, etc. Appearing in this document are trademarks or registered trademarks of their respective companies.

Tips and instructions

Tips: —Important content of special reminders

Notice!—Important elements that may cause damage to the equipment if operated incorrectly

 **Warning**—Important content. The wrong operation may cause equipment damage or even personal injury.

Warning

- Operators should always pay attention to the surrounding environment when collecting data to avoid safety accidents caused by distractions.
- SLAM2000 does not have explosion-proof attributes, and is strictly prohibited to be used near gas stations or in dangerous scenes such as mines, pits, septic tanks, etc. where gas, natural gas, methane, and other flammable and explosive gases gather.
- To avoid fire, property damage and personal injury, use the battery, charging and storage process must follow the guidelines in this manual.

Notice!

- SLAM2000 is a high-precision control device, falling or being hit by external forces may damage SLAM2000, resulting in abnormal operation.
- Ensure that the rotation of the head is not blocked by external forces when the SLAM2000 is powered on.
- Please pay attention to dust and sand prevention when using SLAM2000.

Configuration list

SLAM2000 Workbox Packing List

Number	Name	Quantity
1	SLAM2000 HANDHELD LASER SCANNER	1
2	SP30 lithium battery module (handle)	1
3	SLAM2000 Base	1
4	Type-C to Type-C data cable	1
5	Aviation plug-in cable	1
6	RTK Fixed Base	1
7	RTK Fixed Base Screws	5
8	USB Dongle	1
9	Cleaning Cloth	1
10	Screwdriver	1
11	Certificate of Conformity	1
12	After-sales Service Information Registration Card	1
13	Warranty Card	1
14	Product Manual	1

Product Introduction

Product Overview

SLAM2000 is a high-precision handheld LiDAR scanner innovatively developed by Feima Robotics. The device has a panoramic laser field of view, integrated vision camera and coloring camera, built-in high-precision IMU unit and high-performance computing unit, and real-time high-precision data acquisition. SLAM2000 can be expanded with external RTK, backpack, power supply, tripod and other equipment, widely used in confined spaces, square meter surveying and mapping, emergency rescue, real-time navigation and other scenarios.

Product Features

Panoramic Laser Field of View

The use of hemispherical non-repeating scanning laser, integrated 360-degree rotating head, can form a panoramic laser field of view angle, to ensure all-round, multi-angle data acquisition, to achieve "What you see, what you see is what you get," the high-efficiency scene data conversion.

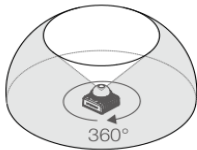

Horizontal

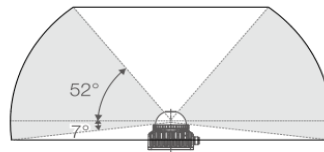

Vertical

High Precision Survey

Built-in high-precision inertial IMU can effectively control cumulative error. high-precision radar calibration algorithms to further enhance the laser sensor accuracy. industry-grade SLAM algorithms to achieve high-precision surveying.

Real Time Mapping

Real-time map construction is available, i.e., map construction is carried out in the process of data collection, and the resultant data is output directly after the completion of data collection, which is suitable for application scenarios requiring timeliness of results, such as emergency rescue and real-time mapping.

Vision Camera

The 12-megapixel vision camera can acquire and run vision SLAM algorithms to provide matching feature points for weakly structured texture environments, avoiding errors due to structural repetition and matching errors and improving the scene applicability of the device. The vision camera can also be used as a high-resolution detail camera to acquire high-definition images of localized scenes.

Coloring Camera

One-inch CMOS sensor, 12-megapixel resolution, 210° field of view angle. Can obtain a larger range, higher resolution of the ground texture information. The color assignment algorithm is optimized for mapping scenes, and the color point cloud is more clear and detailed.

Rich Extension

SLAM2000 has a wealth of external expansion, support for handheld, backpack, static station mode, and support for external power supply, RTK, network module, and so on, can meet the user more application needs.

Software Package

SLAM GO POST

PC-based data processing software can perform one-click SLAM mapping, coordinate conversion, point cloud coloring, etc. It also supports point cloud view, editing, data roaming, and measurement functions.

SLAM GO

Mobile APP software, support Android and iOS system, support device parameter setting, real-time build map data view, device firmware upgrade and maintenance and other functions.

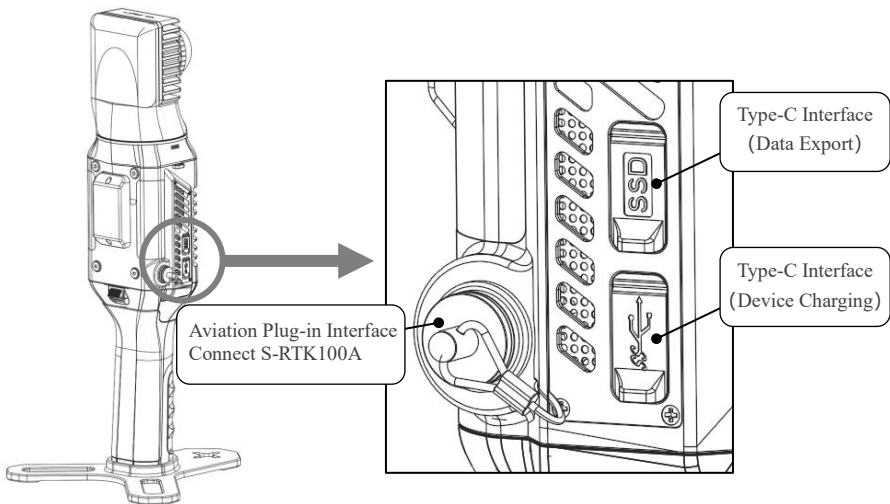
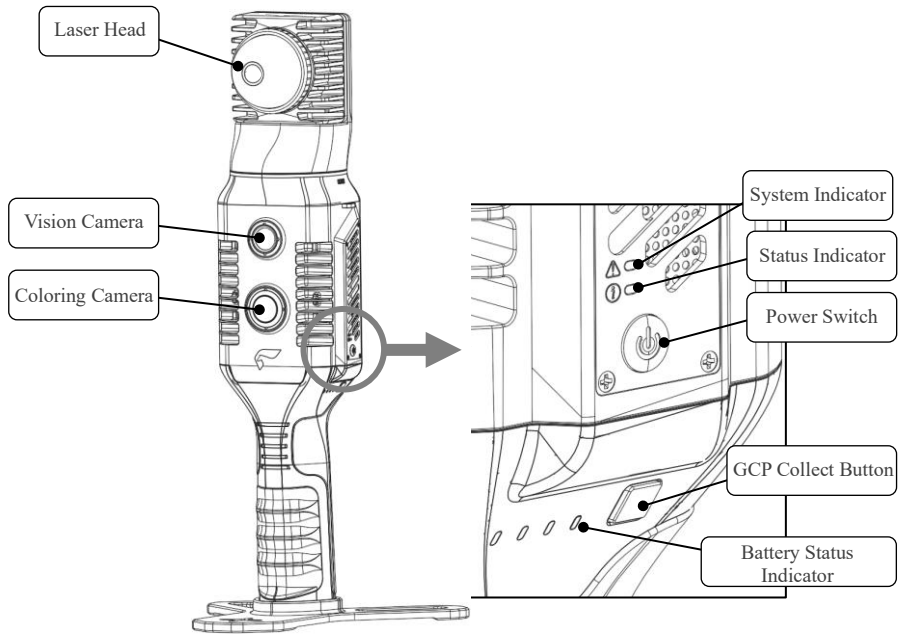

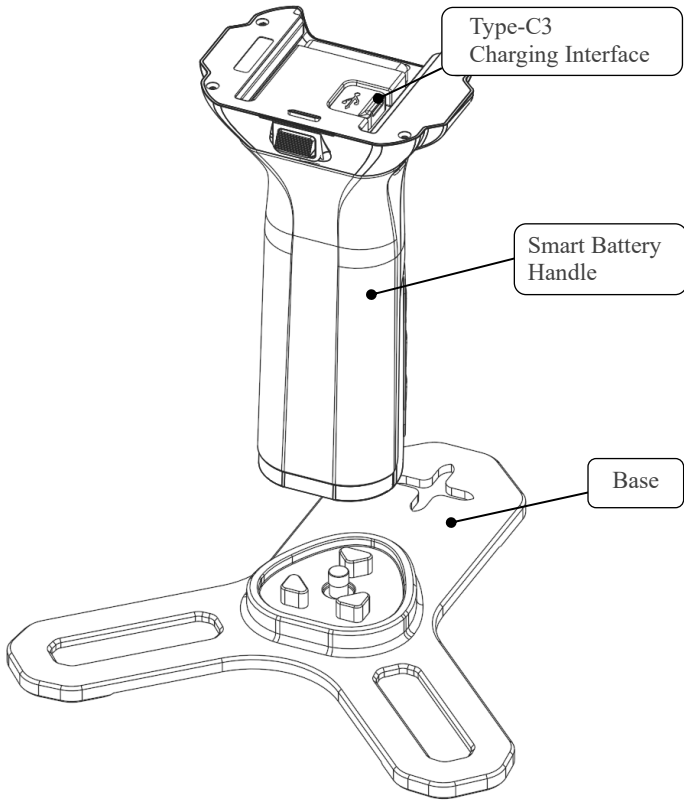

System Parameters

SLAM2000

Component	Name	Parameter
Total	Model	SLAM2000
	Weight	925g (Body) 1450g (With handle, With base)
	Size	L×W×H (Body) 94.5 mm×84.6 mm×219mm
		L×W×H (With handle, With base) 170 mm×173.8 mm×364.5 mm
	Power Consumption	20W(Typical)
	Input Voltage	20V
	Storage Space	512GB SSD
	Operating Temperature	-20°C ~ +50°C
	Storage Temperature	-40°C ~ +70°C
	Operating Humidity	< 95%
	Protection Class	IP54
	Laser Field of View	Panoramic 360°
	Working Mode	Mobile, Station
	Laser Part	Laser Wavelength
Eye Safety Level		Class 1
Range(@100klx)		40m@10% reflectivity 70m@80% reflectivity
FOV		360° Horizontal, -7~52° Vertical
Random error in ranging (1σ)		≤2cm(@10M)
Angular random error (1σ)		≤0.15°
Point Frequency		200kpts/s
Echo		Single Echo (First or Strongest Echo)
Point Cloud Frame Rate		10Hz (Typical)
Color Camera	Pixel	12 Million
	Field of view (diagonal)	210°

Vision Camera	Pixel	12 Million
	Field of view (diagonal)	100°
Interaction	Type-C 1	SSD Memory Data Copy
	Type-C 2	Charge + Extended Functions
	Aviation Plug	Interacts with S-RTK100A, Power Supply
	WiFi	Supply
Li-Ion Battery	Model	SP30
	Charging Interface	Type-C3
	Input Voltage	5-20V
	Output Voltage	10.8V
	Battery Capacity	3000mAh
	Standard	GB31241-2014S
	Weight	About 400g
	Dimension	Length×Width×Height 85 mm×60 mm×144.5 mm
Endurance	95min (Separately Powered SLAM2000)	

[1] The test conditions were ambient temperature +25°C, 80% reflectivity of the target object, and a test distance of 10m.

Product Use

SLAM2000 Usage Process

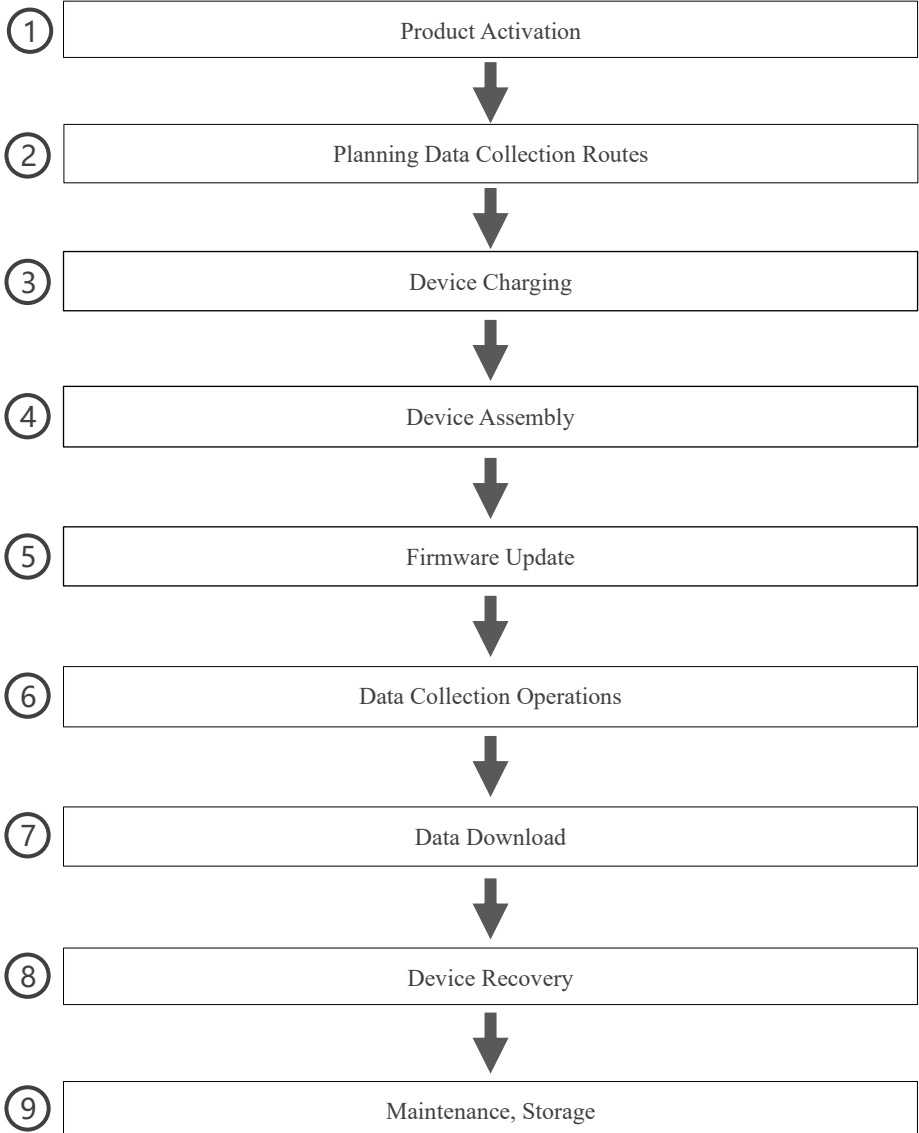

Device Assembly

1 Mounting Base

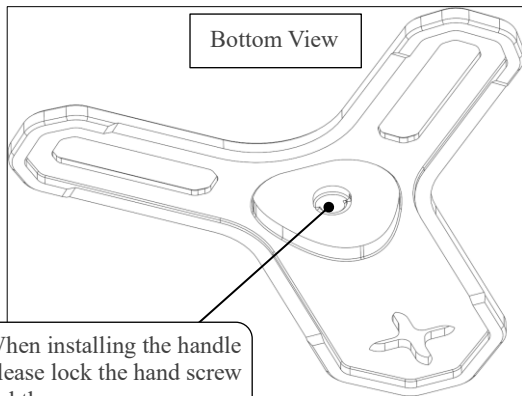
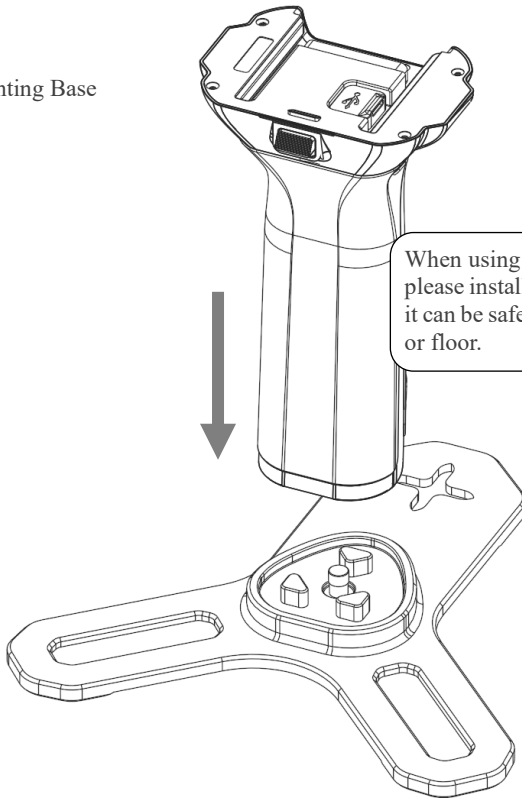

2 Assemble Handle

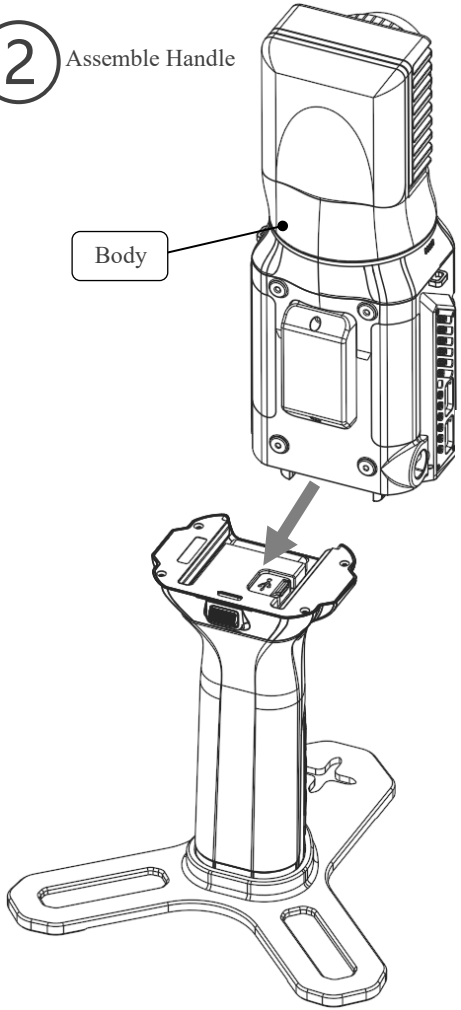

When installing the handle, first align the slide rail under the handle with the slot above the handle and then push it in, after installing it in place, you can hear the "click" sound, check that the release button at the back of the handle is fully rebound, and the joints between the body and the handle have been aligned and are solid and free of looseness.

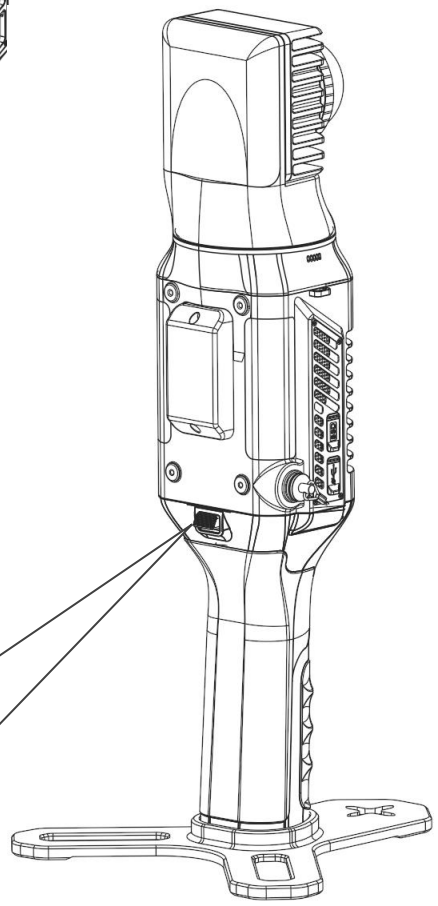
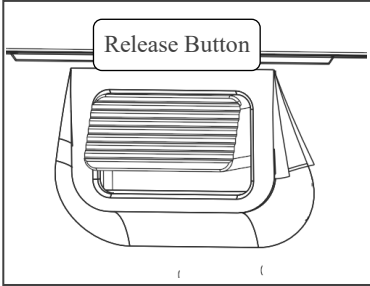

3

Installation of S-RTK100A
(Optional)

Align the screw holes of the S-RTK100 bracket with the pre-drilled screw holes on the back of the SLAM2000, and secure the S-RTK100 bracket to the back of the SLAM2000 unit using the 4 screws (M2.5 x 6) included in the box.

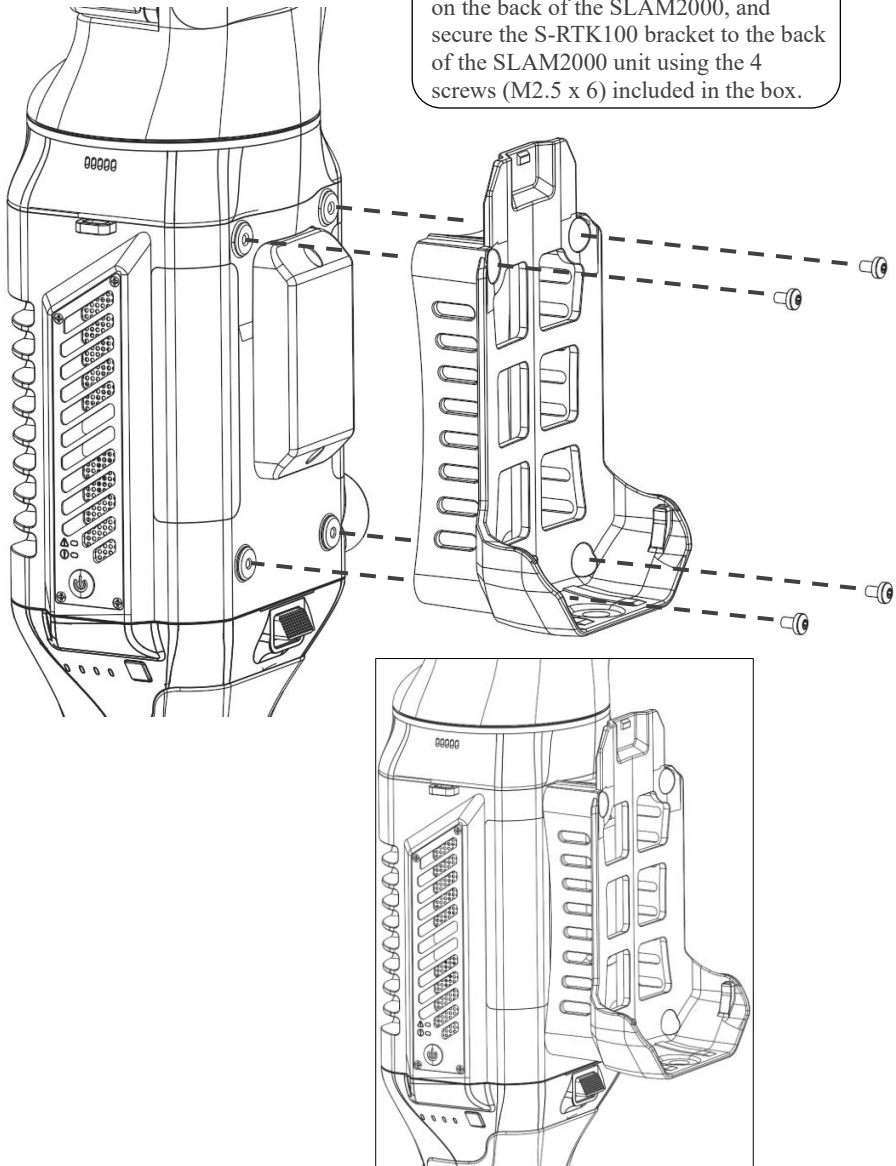

Insert the S-RTK100 into the bracket from top to bottom and hear a "click" sound to check that the S-RTK100 fits tightly and securely into the bracket.

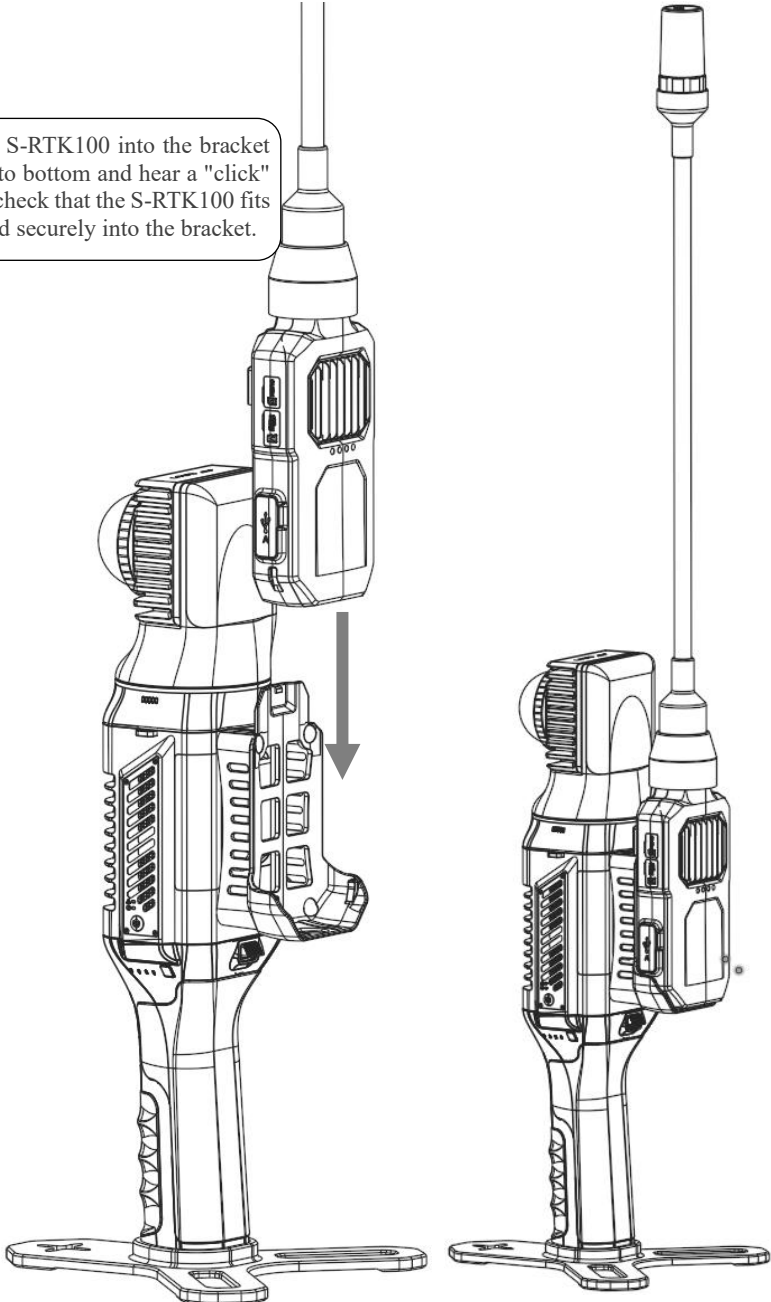

Connect SLAM2000 with S-RTK100 using the aviation plug cable.

Pay attention to the differentiation of the aviation cable ports when connecting, the aviation cable has anti-reverse insertion design and red and blue markings at both ends, reverse can not be inserted, the blue end of the aviation cable is connected to the SLAM2000 aviation port, and the red end of the aviation cable is connected to the S-RTK100 aviation port, pay attention to the red/blue markings of the aviation cable port and the red/blue markings of the aviation port of the device are aligned before inserting it.

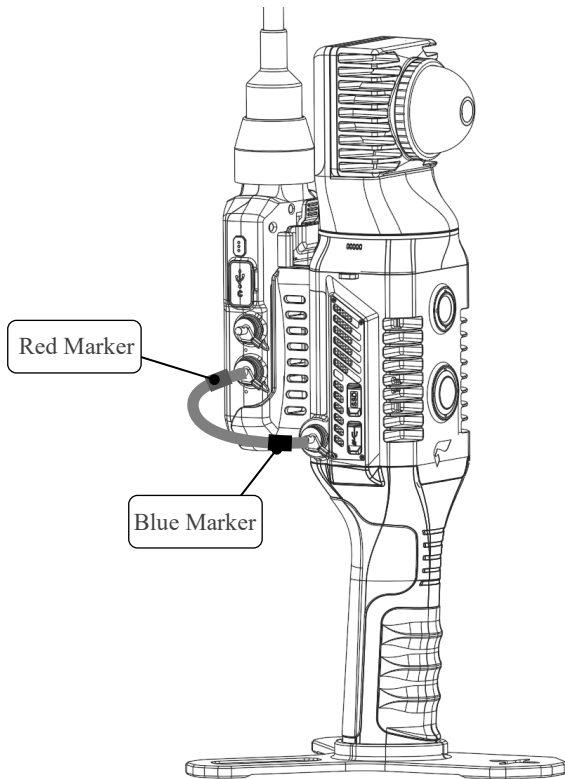

i Learn more about the S-RTK100 in the S-RTK100 Product Manual.

Equipment Recovery

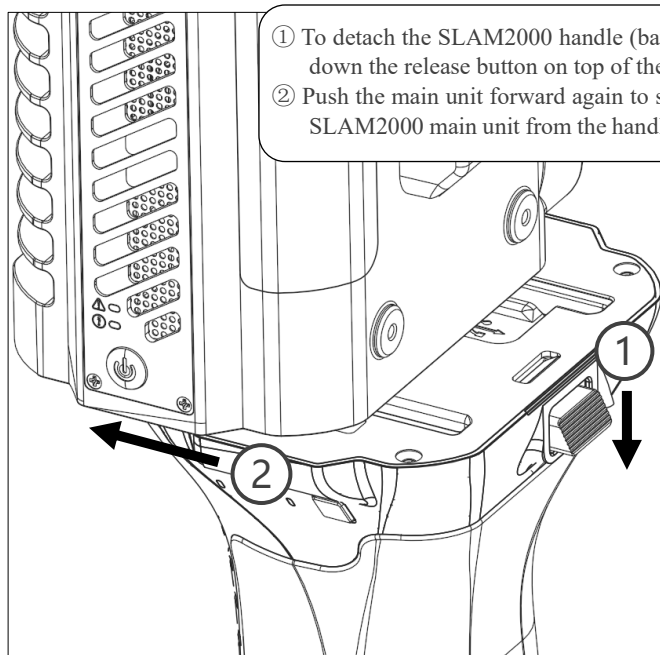
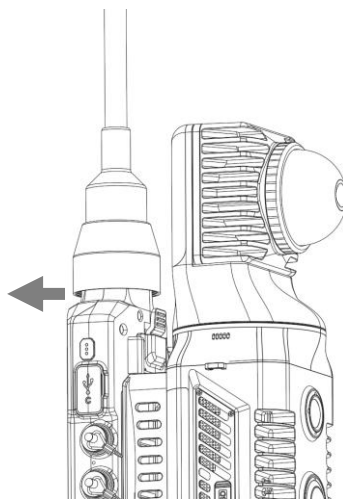
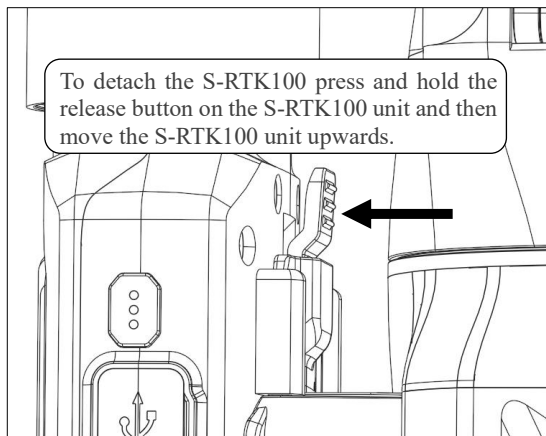

Indicator Description

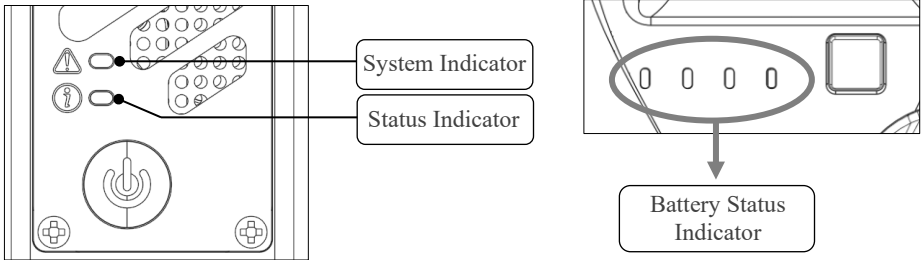

LED	Display	Display Description
System Indicator	White Light On	System Firmware Upgrade in Progress
	Red Light Flashing	System Not Ready
	Blue Light Always On	System Ready
Status Indicator	White Light Fast Flashing	MCU Firmware Upgrade in Progress
	Red Light On	Device Initialization in Progress, Not Ready
	Green Light On	Device Ready
Buzzer	Green Light Flashing	Data Collection in Progress
	Power On	One Beep
	Shutdown	One Beep
	Low Battery	One Beep Every 10 Seconds
	Ultra Low Battery	Tick Every 1 second
	Mark Point Information Collection	Point Information Collection Successful Tick
	Start Collection	One Beep
	Stop Collection	One Beep

SLAM2000 Battery LED Indicator Status List

Status		LED1	LED2	LED3	LED4
Discharge Protection Status	Undervoltage	Flash(5Hz)	Slow Flash(1Hz)	Out	Out
	Discharge Low Temperature	Flash(5Hz)	Out	Slow Flash(1Hz)	Out
	Discharge Over Temperature	Flash(5Hz)	Out	Out	Slow Flash(1Hz)
	Discharge Overcurrent	Flash(5Hz)	Slow Flash(1Hz)	Slow Flash(1Hz)	Out
	Discharge Short Circuit	Flash(5Hz)	Slow Flash(1Hz)	Slow Flash(1Hz)	Slow Flash(1Hz)
Charge Protection Status	Overvoltage	Slow Flash(1Hz)	Out	Out	Flash(5Hz)
	Charging Low Temperature	Out	Slow Flash(1Hz)	Out	Flash(5Hz)
	Charging Over Temperature	Out	Out	Slow Flash(1Hz)	Flash(5Hz)
	Charging Overcurrent	Slow Flash(1Hz)	Slow Flash(1Hz)	Out	Flash(5Hz)
Power Indicator	0%~12%	Slow Flash(1Hz)	Out	Out	Out
	13%~24%	Always On	Out	Out	Out
	25%~37%	Always On	Slow Flash(1Hz)	Out	Out
	38%~49%	Always On	Always On	Out	Out
	50%~62%	Always On	Always On	Slow Flash(1Hz)	Out
	63%~74%	Always On	Always On	Always On	Out
	75%~87%	Always On	Always On	Always On	Slow Flash(1Hz)
	88%~100%	Always On	Always On	Always On	Always On

Status	LED1	LED2	LED3	LED4	Status
Charging Indicator	0%~24%	LED1->LED4 Streaming Lamp Display			
	25%~49%	Always On	LED2->LED4 Streaming Lamp Display		
	50%~74%	Always On	Always On	LED3->LED4 Streaming Lamp Display	
	>=75%	Always On	Always On	Always On	Slow Flash(1Hz)
	Full	Always On	Always On	Always On	Always On
Upgrade Status		Slow Flash(1Hz)	Slow Flash(1Hz)	Slow Flash(1Hz)	Slow Flash(1Hz)

Description: The LED will light up for 6 seconds when you press the key to check the power level, the first 3 seconds will show the power level, the last 3 seconds will show the power level if the battery is normal, otherwise it will show the protection status.

Charging Method

The SLAM2000 battery can be charged by connecting the charger to the battery via a Type-C cable.

Mode 1: The charger is connected to the Type-C port on the SLAM2000 grip for charging.

Mode 2: When the grip is mounted to the SLAM2000 body, the charger is connected to the Type-C port on the underside of the body for charging.

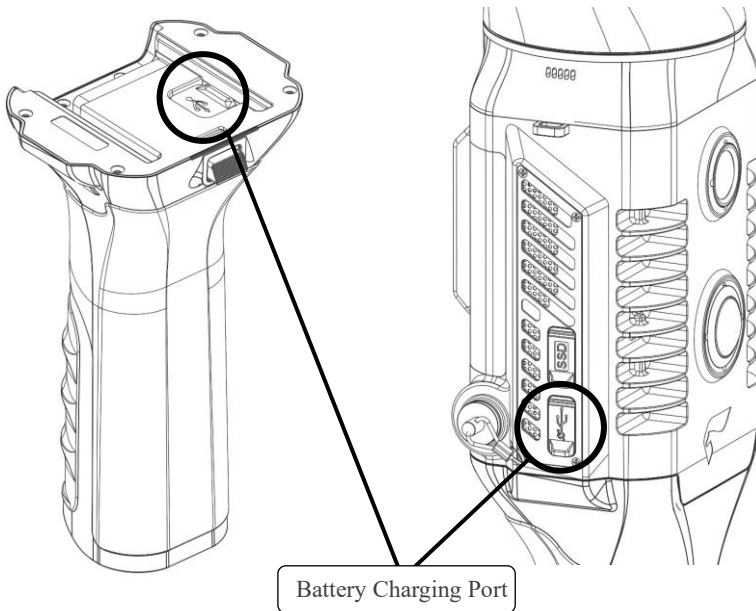

Device Power Supply

SLAM2000 scanner handle internal integrated 3000mAh replaceable lithium battery, safer and more reliable. Working voltage 10.8V, each battery single continuous working time of about 95min (separate power supply SLAM2000). The battery in normal maintenance under normal use conditions, charge and discharge cycle times ≥ 500 times.

Notice!

【Charge】

- Do not use non-standard power adapter to charge the battery。
- If the temperature of the battery is high after the operation, it is necessary to wait until the battery is reduced to room temperature before charging the battery, and the ambient temperature of battery charging is required to be within the range of 5°C to 40°C。
- Please charge in the isolated area, away from flammable materials。
- To avoid the danger of electric shock, please do not open the charger without authorization。

【Operation】

- Battery use temperature is required to be controlled at -10°C~+50°C, if the battery temperature is too low, it will affect the lithium-ion activity and discharge efficiency.
- Please make sure the device connection port is dry and free of water before connecting and installing.
- Please keep the Smart Battery Grip out of direct sunlight.
- Using the battery in a low temperature environment (-10°C ~ 15°C) will reduce the battery capacity and discharge voltage, it is recommended to preheat the battery to 15°C or above before use, and it is better to preheat it to 20°C or above.
- Do not remove the battery directly from a powered device.
- Low battery temperature triggers low temperature charging protection and prevents charging.
- Do not continue to use a battery that has been deformed by a fall or impact.
- If the battery accidentally falls into water, immediately remove the battery and place it in a safe, open area, away from the battery until it is completely dry. Air-dried batteries should not be reused and should be disposed of properly according to the disposal instructions in this document.
- If the battery fire occurs, please use water, water mist, sand, fire blanket, dry powder, carbon dioxide fire extinguisher to extinguish the fire immediately, the fire is very easy to

explode. Please choose the fire extinguishing method according to the above recommended order according to the actual situation.

- It is strictly prohibited to use batteries that are not officially provided by Feima Robotics. If you need to replace the battery, please purchase it from the official website of Feima Robotics or the designated channels. Feima Robotics is not responsible for battery accidents or equipment failures caused by the use of batteries other than those provided by Feima Robotics.
- Battery storage temperature and humidity requirements are $-20^{\circ}\text{C}\sim 45^{\circ}\text{C}$, 45%~90%RH.
- It is strictly prohibited to use or charge batteries that are bulging, leaking or damaged. Do not use the battery when it emits a strange odor, becomes hot (the temperature of the battery itself exceeds 60°C), deformed, discolored or any other abnormal phenomenon. If the battery is abnormal, please contact Feima after-sales service or other agents for further treatment.
- Use the battery in an environment where the temperature is between -10°C and 50°C . Excessive temperatures (above $+50^{\circ}\text{C}$) may cause the battery to catch fire or even explode. Too low a temperature (below -10°C) will seriously damage the battery.
- It is prohibited to disassemble or puncture the battery with sharp objects in any way. Otherwise, battery leakage will cause fire or even explosion.
- Do not mechanically strike, crush or throw the battery. Do not place heavy objects on the battery or charger.
- If the battery is dropped or struck by an external force, stop using the battery.
- Do not heat the battery. Do not place the battery in a microwave oven or pressure cooker.
- Do not place battery contacts on a conductive surface (such as a metal table top, glasses, watch, jewelry, or other metal objects).
- Do not short-circuit the positive and negative terminals of the battery with wires or other metal objects.
- If the battery connector is dirty, wipe it with a clean, dry cloth. Failure to do so will result in poor battery contact, which may cause energy loss or charging malfunction.

【Transportation】

- Batteries should be placed in a safe box during transportation to avoid contact with liquids or bumping against hard objects, and never immerse them in water or get them wet. When the battery is exposed to water, it may decompose and cause spontaneous combustion or even an explosion.

【Maintenance】

- After each operation, the battery should be recharged in time, please do not store the low battery for a long time, if not used for a long time, please charge the battery to more than 50% and then store it, and carry out charging and discharging maintenance every 3 months.

【Battery Storage】

- Please store the battery out of the reach of children and pets.
- Batteries should be stored in an explosion-proof box in a cool and dry place, prohibited from prolonged exposure to high temperatures and avoid direct sunlight.
- Do not place the battery near a heat source (furnace or heater, and so on), and do not leave the battery in a car on a hot weather day. Do not store the battery in an environment that exceeds 60°C. The ideal storage temperature is 22°C - 28°C.
- May not be stored in multiple occurrences of alternating high and low temperature environments.
- May not be stored in a fully charged transportation box when the battery temperature exceeds 45°C.
- Prolonged low battery storage will result in over-discharge of the battery, which may even cause the battery to be scrapped in severe cases.
- Do not place sharp objects with or puncture the batteries.
- Prevent the battery from being dropped and knocked.
- Store the battery in a dry environment.
- Do not store the battery for long periods of time after it has been completely discharged to avoid over-discharging the battery and causing damage that will make it impossible to restore it to service.

【Battery Disposal】

- Prohibit disassembling, impacting, extruding the battery or putting it into fire, please do not put the battery in a high temperature environment.
- If the battery is bulging, broken or leaking, please do not use it again and dispose of it in time.
- Be sure to discharge the batteries completely before disposing of them in the designated battery recycling bin. Batteries are hazardous chemicals and should not be disposed of in the regular trash. For details, follow your local battery recycling and disposal laws and regulations.
- If the battery cannot be completely discharged, please do not dispose of the battery directly in the battery recycling bin and contact a professional battery recycling company for further processing.

Data Storage

- SLAM2000 uses built-in SSD memory with a capacity of 512GB, and connects to a PC via a data cable for data interaction.
- SLAM2000 SSD interface (Type-C1) supports reading data in the shutdown state.

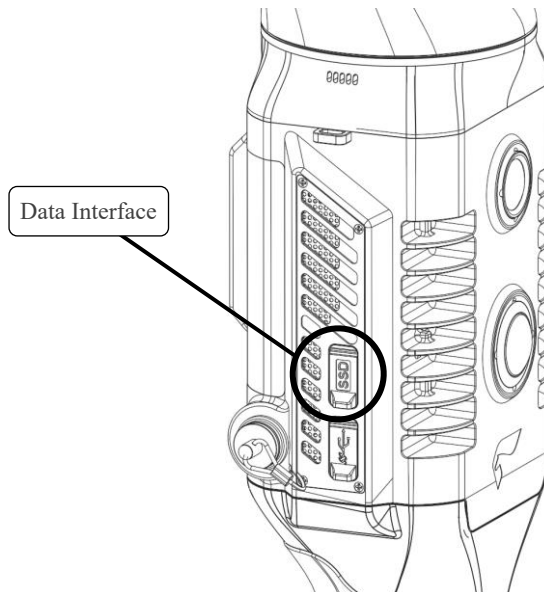

Notice !

- There are two Type-C ports on the side of SLAM2000, the upper one is for data and the lower one is for charging.

Product Activation

Before using the scanner, you need to register your Feima account and activate the device, see the "SLAM GO" section in the attached document for details on where to get the software and how to register and activate it.

Data Collection

Device Power On

Long press the scanner ON key for 3 seconds, the laser head starts to rotate for self-test, wait....

- System indicator [Blue light is always on].
- Status indicator [Green light is always on].
- The laser head stops rotating.

At this point, the device starts successfully and is in standby mode.

Notice !

- Hold the scanner smoothly and keep the laser head upright when the device is turned on.
- Do not rotate the laser by hand after the self-test of the device is completed.
- The scanner can also be placed on a safe and stable table or flat surface.

Start Collection

The scanner needs to be calibrated before starting data collection and should be placed at a distance of >0.4 meters from the object to be measured and not too far away. The resting phase should take at least 60 seconds before motion acquisition begins. The scanner should not be held in the hand while resting, but must be placed smoothly on a fixed surface such as a secure floor or tabletop.

Short press the scanner on the key, the status indicator will first be changed to [Green Fast Flash] (2Hz), at this time the device is being calibrated, the length of 60 seconds (cell phone APP will show a countdown to read the seconds), the laser head will not rotate during the calibration phase, after 60 seconds the status indicator will be changed to [Green Slow Flash] (1Hz), the laser head will begin to rotate and data acquisition. Static position, such as placing the position slightly tilted but can ensure that the scanner is not static also meets the static requirements.

Tips:

- Keep the scanner in front of your body during data collection, in the same direction as you walk, with the laser head facing up.

GCP Collection

When you need to collect control points, please first align the cross center of the device base to the control point, then press the control point collection key, after hearing a "Di!", the control point collection is successful, there is no need to wait for the collection of control points, after collecting the information of the current point, you can continue to collect the data after.

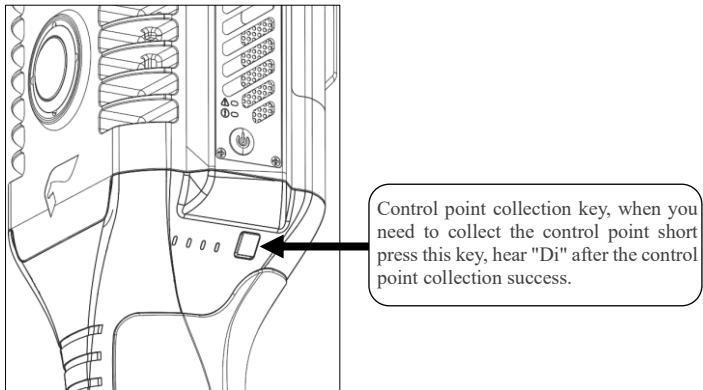
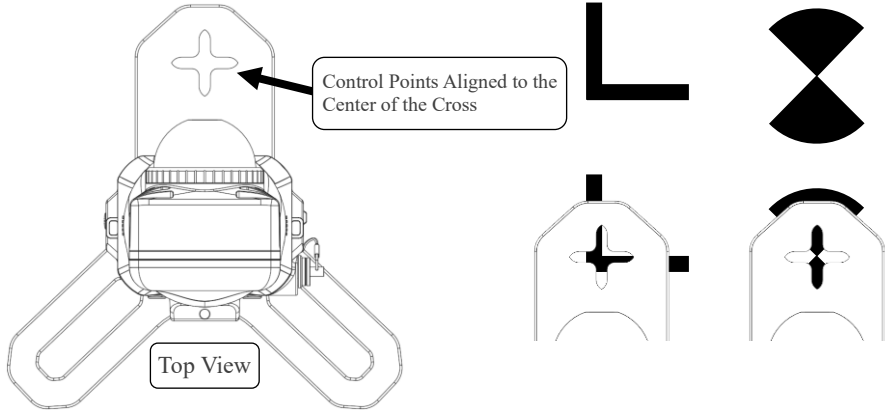

Stop Collection

Short press the scanner ON/OFF key to end data acquisition, the status indicator returns to [Green light always on] standby state, and the laser head stops rotating.

If you need to get the results of " Real-time Mapping Result", please wait for the equipment to finish the " Real-time Mapping" before the equipment is shut down or the next acquisition, the waiting time is about 1/25 of the acquisition time.

Example: The acquisition time is 25 minutes, and you need to wait for 1 minute after stopping the acquisition.

Equipment Shutdown

Press and hold the scanner ON/OFF key to turn off the device, and wait until the system indicator and status indicator are all off, at which time the device is turned off.

Notice!

- Do not disassemble the handle to disconnect the power until the system indicator and status indicator are all off.

Data Checking

After data collection, turn off the scanner, connect SLAM2000 to the PC with the data cable, find the folder named "SN_XXXXX" and copy it to the backup directory. The system will automatically generate this folder every time the data collection is completed, and the order of data collection can be recognized according to the size of the folder name and the number at the end of the folder.

Problem Analysis

When there is a problem with the collected data, please pack and compress the folder named "LOG" in the scanner's memory card and submit it to Feima's after-sales department for analysis.

SLAM GO Operating Instructions

Overview

Description

SLAM GO APP is a high-end supporting application specially built for SLAM2000, realizing an efficient solution for lightweight mobile real-time viewing and processing of scan data. The app can connect to SLAM2000 wirelessly, display 2D and 3D scan data in real time, and support real-time viewing of modeling models and its positioning. SLAM GO diverse functions will greatly improve user efficiency and convenience in real-world application scenarios, making it the preferred application for many professionals.

Device Environmental Requirements

Android 8.0/HarmonyOS 2.0 and above operating system.

iPhone iOS12.0/iPad iPadOS12.0 or later version.

Installation Method

Download for Android: <http://ios.feimarobotics.com/3vu9>



 SLAM GO

IOS version download: Search for SLAM GO in the App Store to get it.
Google play store & Apple store.

Notice

- The S-RTK interface style of SLAM GO APP may be different with the version iteration of SLAM GO, the illustrations in the following description may not be consistent with the actual interface of the SLAM GO you are currently using, please refer to the interface of the latest version of SLAM GO.

SLAM GO Registration and Login

Register Feima account

Register by Phone Number

Click **User** on the home page of the APP, click **Register New User** to enter the registration page, select the correct international area code (for example China's international area code is +86), fill in the correct cell phone number, and get the verification code. Enter the password, the password length should be no less than 6 digits. Check the 'I have read and agree to the user agreement, privacy policy' option at the bottom of the page, click **Register**. After registration, you can log in. This account can log in to all products of Feima once required.

Register by E-mail

Click **User** on the home page of the APP, click **Register New User**, click **Email Registration**, you can enter the email registration page, fill in the correct email address (example: xxx@outlook.com), and get the verification code. Enter the password and confirm the password, the password length should be no less than 6 digits. Check the option of **I have read and agree to the user agreement and privacy policy** at the bottom of the page, click **Register**. After registration, you can log in. This account can log in to all products of Feima once required.

Sign up FeimaRobotics
FeimaRobotics account can authorize and sign in to all FeimaRobotics products

+1 Phone number

Password

Confirm password

enter your code here [Send](#)

[Forget your password?](#) [Sign in](#)

[Sign up](#)

I have read and agree to [\(User Agreement\)](#), [\(Privacy Agreement\)](#)

Sign in FeimaRobotics
FeimaRobotics account can authorize and sign in to all FeimaRobotics products

+1 Phone number

Password

[Forget your password?](#) [Sign up](#)

[Sign in](#)

I have read and agree to [\(User Agreement\)](#), [\(Privacy Agreement\)](#)

Login Account

Phone Number Login

Open the SLAM GO APP, click **User**, select the correct international area code (e.g., China's international area code is +86), fill in your Feima cell phone account and password, check the **I have read and agree to the user agreement, privacy policy** option at the bottom of the page, and click **Login**.

E-mail Login

Open the SLAM GO APP, click **User**, click **Email Login** on the pop-up login page, fill in your Feima email account and password, check the **I have read and agree to the user agreement, privacy policy** box at the bottom of the page, and click **Login**.

Other Login Entries: ① Click **S-RTK** on the main interface to log in. ② Click **Project - My Project** under **Login** to log in.

If you forget your password, you can reset it by going to the **User** interface and clicking the **Security Center** option, or go to **Forgot your password.** on the login page and follow the instructions to retrieve your password.

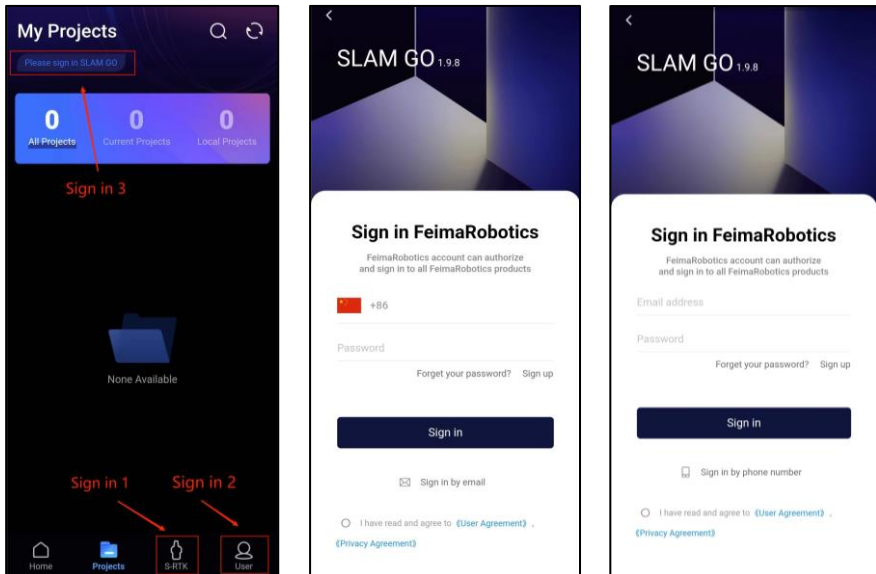

Phone number/E-mail account login

Personal Center

Personal Center - **User** includes user name and avatar display, modify user name, security center, activation request view, language setting, permissions and privacy settings, about SLAM GO, and sign out.

When you install SLAM GO for the first time, you need to click Personal Center - **User** to log in before you can use all the functions of the app.

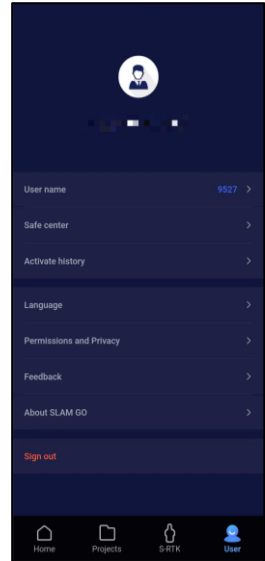

Change Login Password

Click on **Safe Center – Change Password** in the personal center, enter the old password, new password, and confirm the new password in the input box. Click **Confirm** to make the modification successful. The system will automatically log out of the current account. Please restart the software to log in.

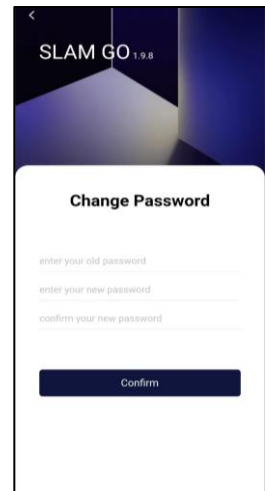

Activation Request

Click on the **Activation Application** button in the personal center to view the activation history of all SLAM2000 scanners under the current account.

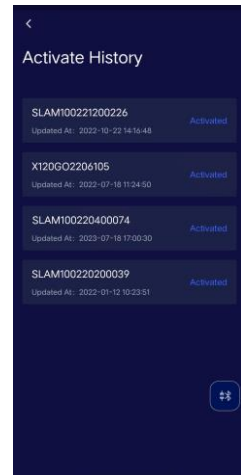

Language Setting

SLAM GO supports multiple languages, including Chinese, English, Italian, German, French, Japanese, Korean, Arabic and so on.

Click on the **User - Language setting**, and in the Language pop-up window, you can select the language you want to switch (when SLAM GO is first started, the default language of the app is the current language of the system).

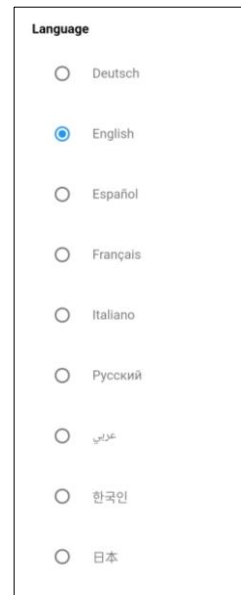

About SLAM GO

You can view the latest and current versions of the app, the copyright ownership of the app, and download and upgrade to the latest version.

Software Upgrade

When you enter SLAM GO home page or **User - About SLAM GO**, the app will automatically detect the version upgrade (need to connect to the Internet). If there is the latest version, the **Upgrade Now** button will be displayed at the bottom of the app home page or the **About SLAM GO** page. Click **Upgrade now**, SLAM GO will automatically download the latest installation package. Then click **Install**, the app will be upgraded to the latest version.

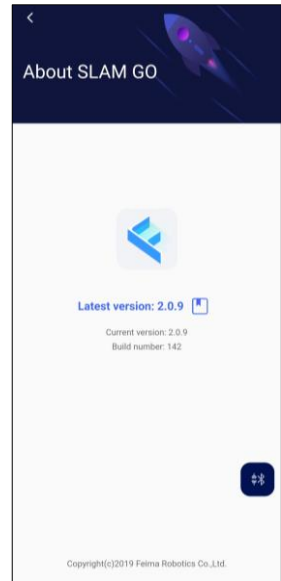

Exit Login

Click **Sign out** to log out of the currently logged in account and return to the login page.

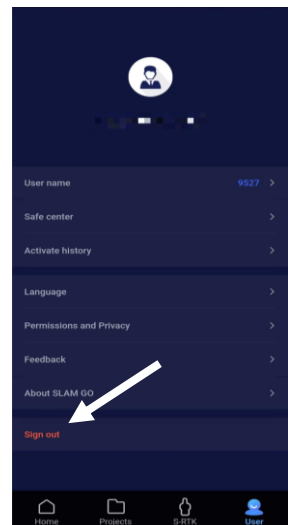

APP Home Page

The home page includes connecting the SLAM2000 scanner, activation history, searching for devices, device types, currently connected devices, and historically connected devices.

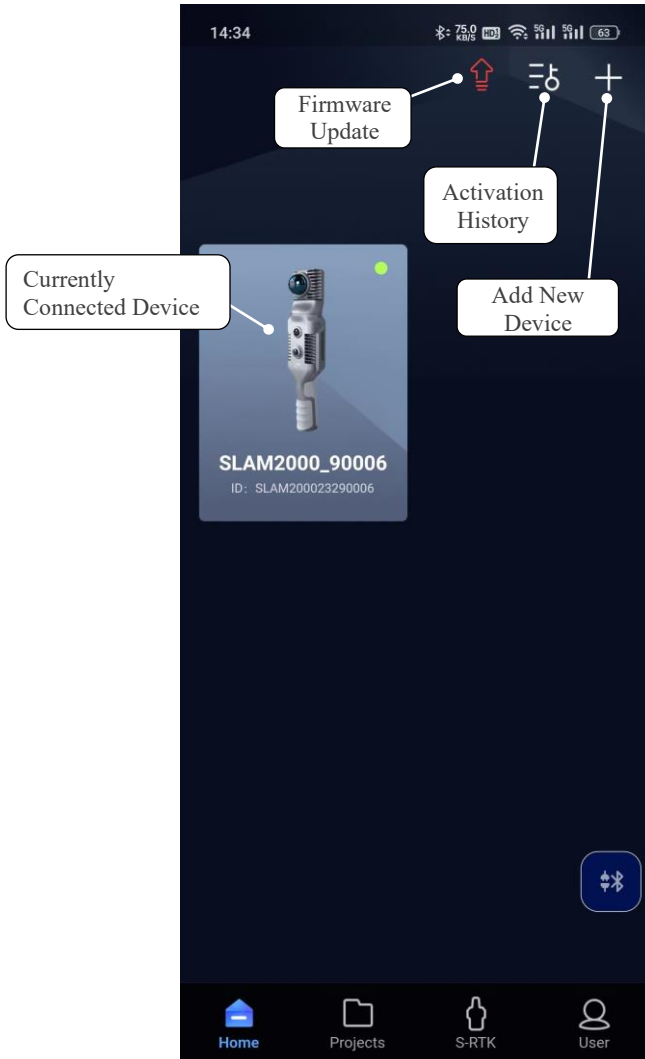

Device Binding

The following two ways are supported to add SLAM2000 to the SLAM GO home page.
Adding through WiFi connection

WiFi Binding

Open the SLAM GO home page, long press the SLAM2000 scanner on/off button for 3 seconds, start the SLAM2000 scanner and wait for a minute or so, connect your phone's WiFi to the AP hotspot of the SLAM2000 scanner. The app home page will automatically display the SLAM2000 scanner device and automatically bind the SLAM2000 scanner to the home page.

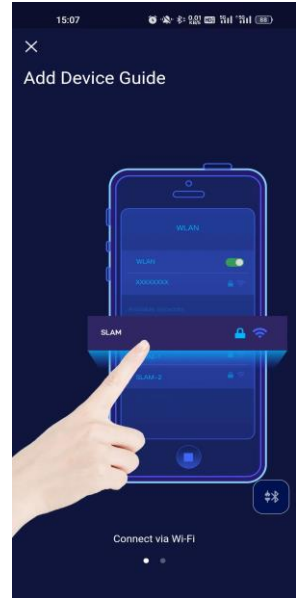

Device Activation

SLAM2000 scanner device activation needs to be activated via SLAM GO. The activation process needs to be approved by Feima after-sales service online before it can be used.

For the unactivated SLAM2000 scanner device, if it bind WiFi to GO for the first time, it will automatically appear on the SLAM GO homepage.

Click the scanner marked with a green dot in the upper right corner, and the activation information interface will pop up, fill in the activation information, and follow the steps below to activate the device successfully.

Before activating the SLAM2000 scanner, please contact Feima after-sales in advance for assistance of online activation.

Activation Process

1. Connect your phone to the inactive SLAM2000 scanner via WiFi. After the connection is successful, an online device with a green dot in the upper right corner will automatically appear on the home page (if the corresponding device does not appear, please close the application completely and then re-enter the app), click with a SLAM2000 scanner device with a green dot.

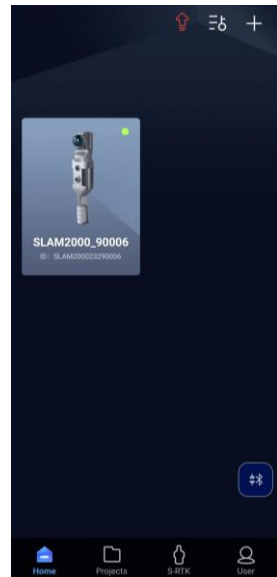

2. Unactivated devices are grayed out. Clicking on it will prompt the **Device not activated**. At this time, it is necessary to disconnect the WiFi connection of the SLAM2000 scanner. While the mobile phone remains connected to the Internet, click the device that needs to be activated on the page again.

3. After clicking the device, the **Activate Device** page will pop up. Fill in the contact name, contact number, and contact unit in turn according to the page requirements, and click the **Finish** button. At this time, the activation application will be automatically sent to Feima after-sales service, waiting for Pegasus After the customer service review is passed, the device can continue to be operated.

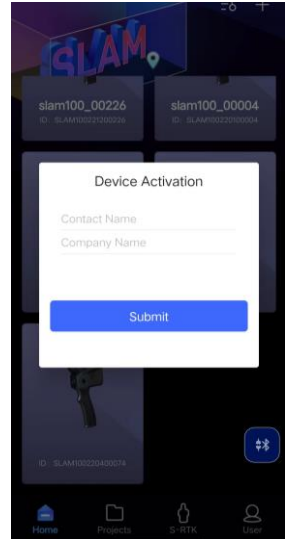

4. After the device activation is approved, please keep your cell phone connected to the Internet and wait for about 1 minute, the device activation information will be automatically uploaded to the server from the app. If the following message appears, it means that the SLAM2000 scanner activation has been approved.

5. After the activation is successful, re-enter the SLAM GO APP. When the prompt **Device activation has passed** appears on the page, click **Confirm**, and connect to the SLAM2000 scanner through WiFi again to complete the synchronous activation of the SLAM2000 scanner and SLAM GO.

Activation Under Review

After completing the activation information, restart the app later and connect to the WiFi of the SLAM2000 scanner, click on the device with a green dot in the upper right corner, and the prompt **Activation application under review** will pop up, please wait for the approval of Feima after-sales service. If it is still displayed for a long time **Activation application is under review**, please contact Feima after-sales service for more assistance.。

Unsuccessful Activation Request

If your activation application fails during the process of activating the SLAM2000 scanner, please contact Feima after-sales service in time and reactivate with the assistance of the service team.

Activation History

Click **Activation History** in the upper right corner of the home page to view the activation history and activation status of SLAM2000 devices.

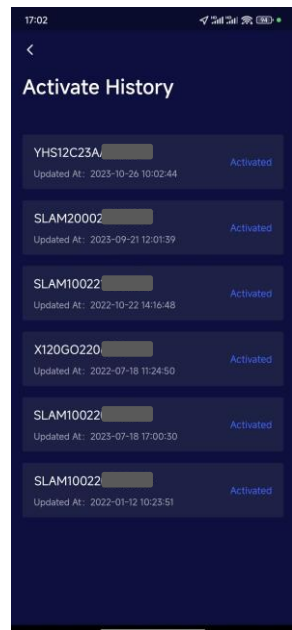

Device Connection Status

Device Status – Successful Connection

Connect to the SLAM2000 scanner through the mobile phone WiFi, click the online device with a green dot logo in the upper right corner of the app page, enter the device working page, and prompt the connection is successful and the device enters initialization.

Device Status – Initializing

After connecting the device successfully, the device will be initialized, and the device will enter the standby state after the initialization is completed.

Device Status – Standby

After the initialization of the device is completed, it will enter the standby state, and the device will not start working at this time.

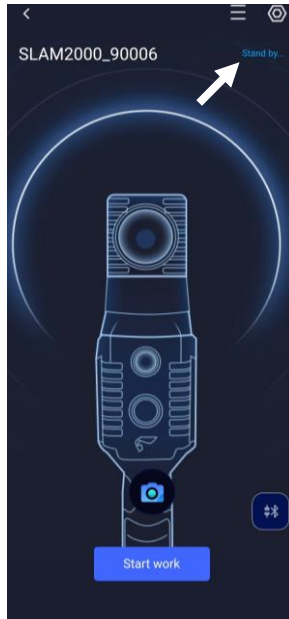

Device Status – Connection Failure

If the device connection fails, please recheck the device connection status and troubleshoot one by one.

- ① Check whether the WiFi of SLAM2000 remains connected to the phone.
- ② Check whether the SLAM2000 status indicator light remains green.
- ③ Exit the working interface, return to the home page, and check whether there is a green cursor in the upper right corner of the connected device icon.
- ④ Try to close the SLAM GO APP completely and clear its background, restart SLAM GO and try to connect the SLAM2000 device again.

If after performing the above operations and re-entering the working interface of the device, it still prompts that the connection failed, please contact Feima after-sales for more assistance.

Device Status – Not in Communication Range

When the SLAM GO APP is disconnected from SLAM2000, the device status will indicate **Not in communication range**, you need to check whether the phone is connected to the WiFi of SLAM2000, or the distance between the phone and the device is too far, the WiFi signal is weak or out of range.

Standby Test Shooting

When the device is in standby mode, please make sure the cameras in front of SLAM2000 are not blocked, and click the shooting button at the bottom of the standby interface to take a test shot and check the camera status. Slide to switch to visual camera and coloring camera.

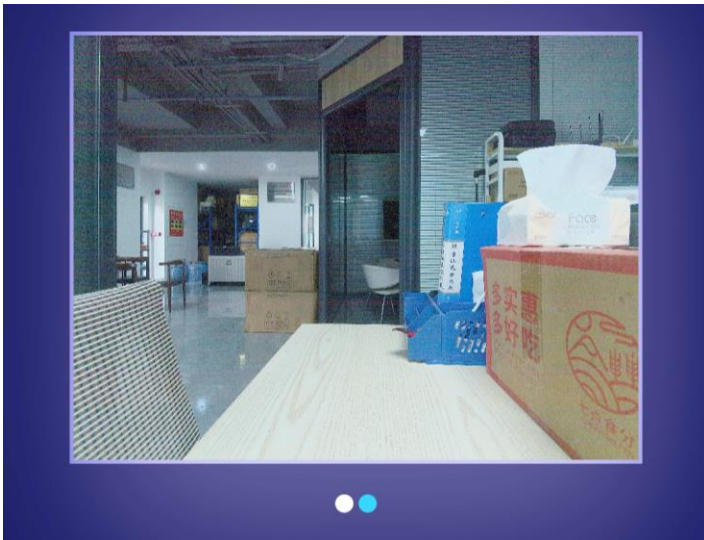

Device Working Interface

After connecting SLAM2000 through SLAM GO APP, the APP will enter the standby page, short press the SLAM2000 power button, the system will automatically enter the working page and start to display the laser scanning data in real time.

The device working interface includes the device name, device information, settings, working hours, working status, real-time display, pitch angle control key, and switch between 2D or 3D display.

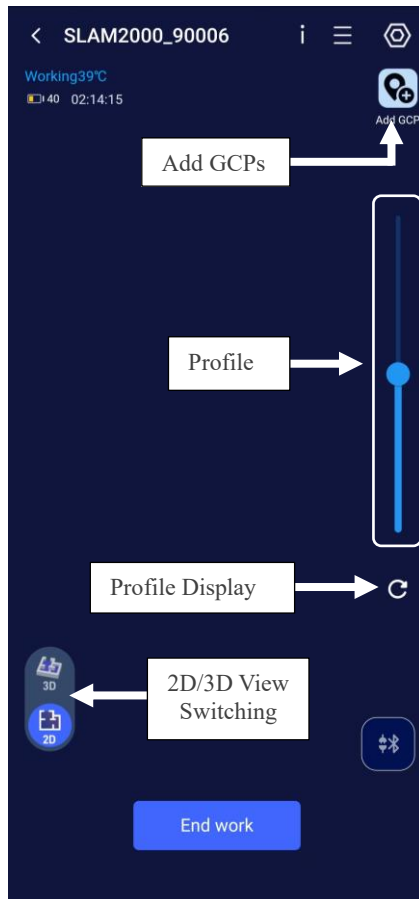

In Work – Real-time 3D Data Display

When the APP is in the standby interface, short press the power button of the SLAM2000 device to start scanning and the page will automatically jump to the 3D scanning display interface.

Note: Before starting work, it is necessary to let the device stand still for one minute to optimize the accuracy of the device when it is working.

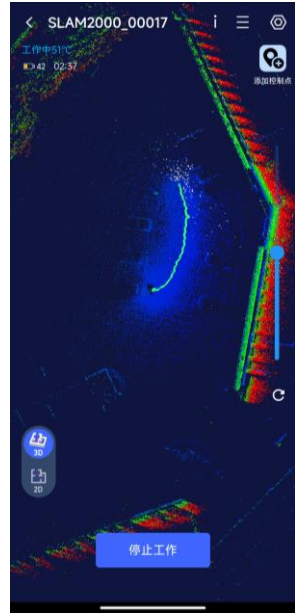
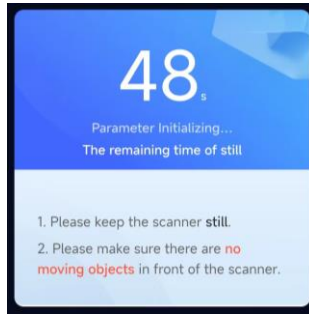

In Work – View SLAM2000 Status Information

During the operation of SLAM2000, click the 'i' button in the upper right corner of the working interface to view the current basic status information, motor status information, error status information and SD card information of SLAM2000 in real time.

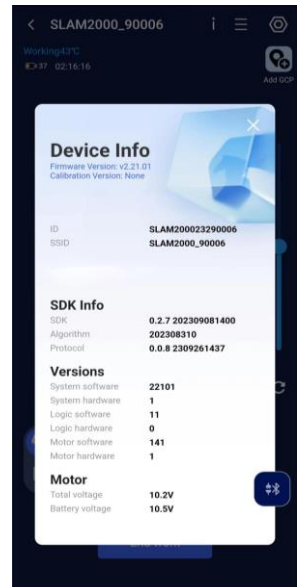

Control Point Acquisition

When the user clicks on "Add Control Point" during the operation, the currently collected time will be recorded in the GCP collection file.

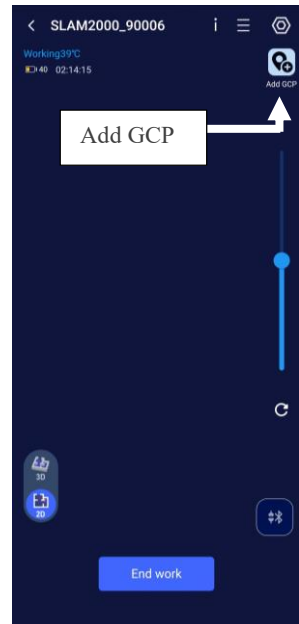
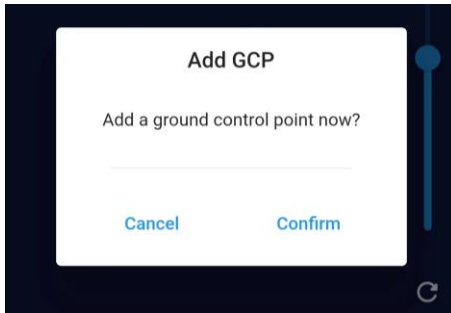

Settings

Click the **Settings** button in the upper right corner of the working interface to enter the settings interface. Click **Regular settings** to enter the settings interface, where you can perform operations such as device name, measurement distance, camera parameters, etc., as well as firmware upgrades.

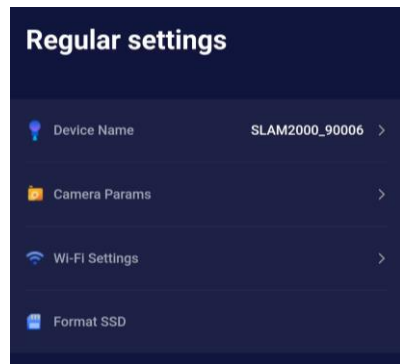
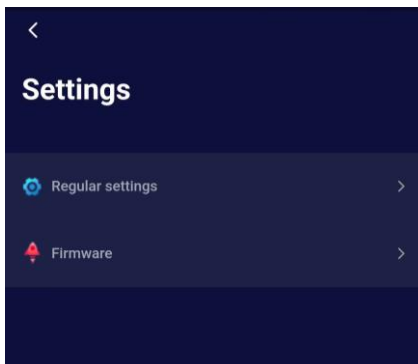

Modify the Device Name

Click the device name, enter the content to be modified in the **Modify Device Name** pop-up dialog box, and click **Confirm** to modify the device name.

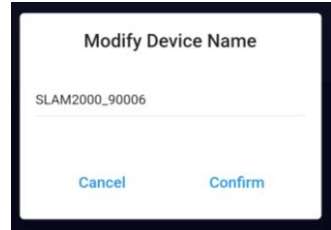

Camera Parameters Settings

【Optical Camera】

When data collection is performed in low-featured scenes such as passages, tunnels, spherical building interiors, etc., You can turn on **【Optical Camera】** , which helps to match the point cloud and calculate the results in the later process. In regular scenes (where the object to be measured has obvious features), this item can be turned off.

【Coloring Camera】

You can turn off the **【Coloring Camera】** when you don't need the point cloud color focusing results, and it can greatly save the storage space of SLAM2000 when this item is turned off.

【Flash Resistance】

When you use the camera function to shoot under the strobe light source such as LED, it may happen that the exposure of the picture is not normal (bright and dark), this is due to the fact that the sampling frequency of the camera and the flicker frequency of the light source are the same or close to each other, you can adjust the value of **【Flash Resistance】** , so that it is staggered with the frequency of flicker of the light source to solve this problem.

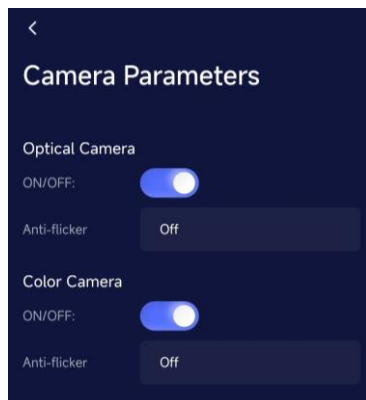

Wi-Fi Settings

Click **Settings** → **Regular Settings** → **Wi-Fi Settings** in the upper right corner of the working interface to enter the WiFi settings interface, where you can manually select the country code and Wi-Fi band of your current SLAM device

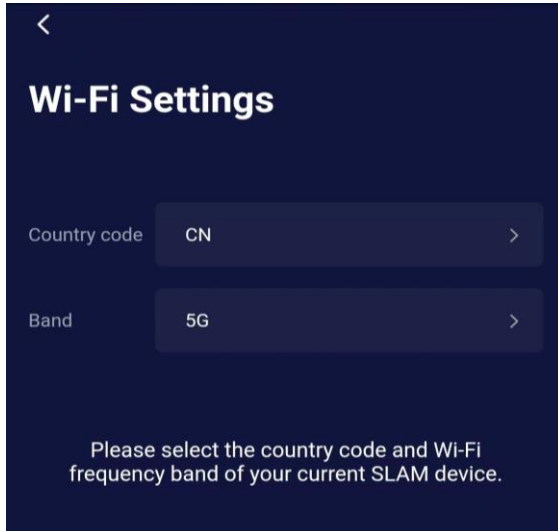

Format SSD

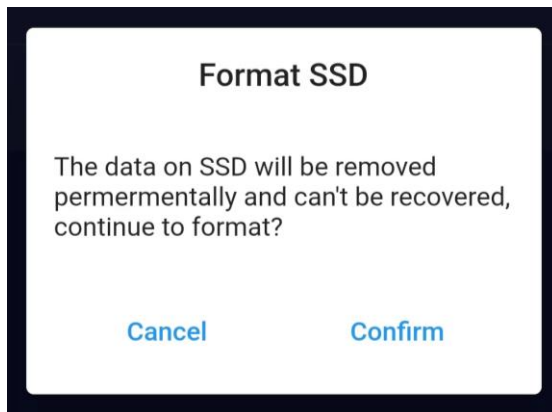

Firmware Update

A firmware update will optimize the performance of the firmware or device drivers, as well as optimize the performance of the processor or other device hardware. And firmware upgrades can also fix problems found with older versions.

➤ Automatic Firmware Upgrade Reminder

Each time you open the app and log in, the app will automatically detect the latest firmware version and the current local firmware version. If the latest firmware file is not downloaded locally, a pop-up window will be displayed on the home page to remind you to download the latest firmware so that you can directly update the firmware after connecting the device.

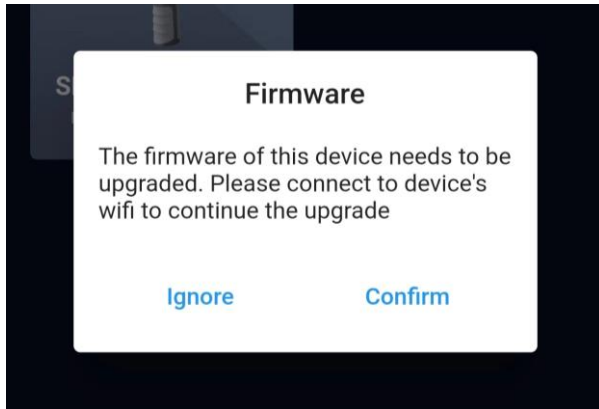

➤ Latest Firmware Download

After the firmware upgrade in the pop-up window on the home page, click **Update** to jump to the firmware download window, click **Update** to start downloading, do not operate the phone at this time, wait for the download to complete, click **Confirm** to exit the firmware upgrade window after the download is complete



➤ **Transfers Firmware to SLAM2000**

- ① If the SLAM2000 is turned on at this time, please turn off the device. Then open the SLAM GO APP first and then turn on SLAM2000, and proceed to the firmware upgrade procedure under the pop-up window prompts on the SLAM GO homepage.
- ② After the transmission is completed, click Confirm. At this time, please wait for 35 seconds and then manually restart the device, after restarting the device, pay attention to observe the device indicator light from the upgrade state to normal standby, this time the firmware update is successful, you can use the device normally.
- ③ You can check the setup page after the upgrade is successful.

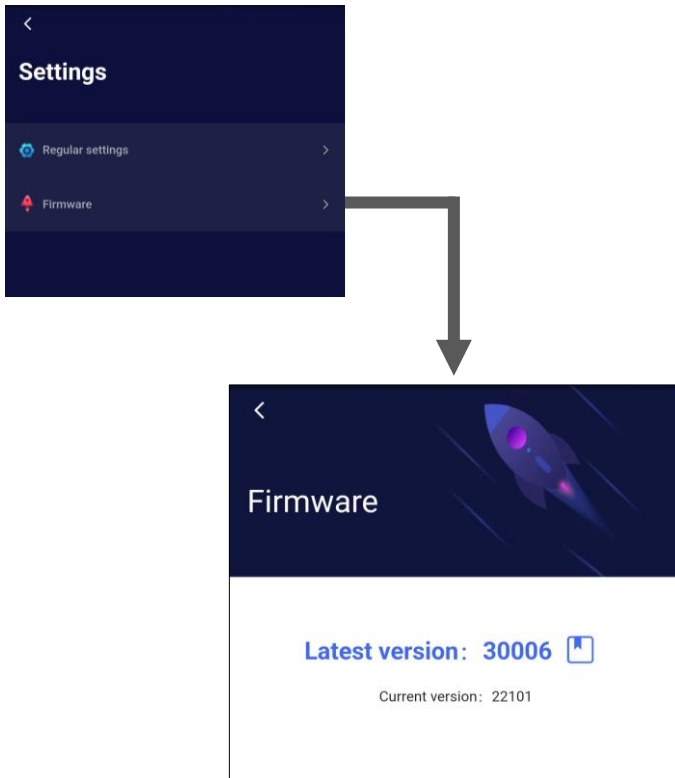

Delete Device

- When SLAMGO and SLAM2000 are connected, enter the working page of the APP, click "Settings" to see the option of "Delete Device", through which you can delete the devices that don't need to appear on the home page.
- Long press a SLAM2000 device icon on the home page of the APP, you can check one or more devices that need to be deleted, and click the "Delete" button at the bottom right corner, and then click "Confirm" in the pop-up window, you can remove the checked devices on the home page.

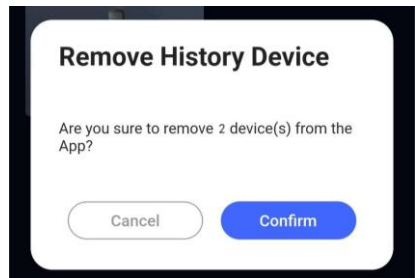
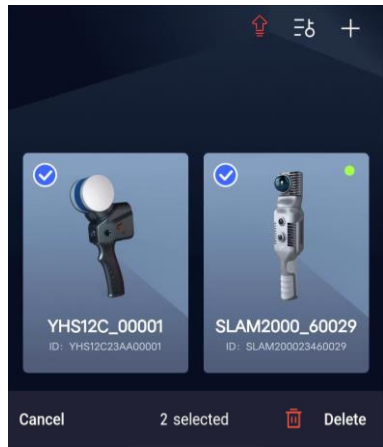
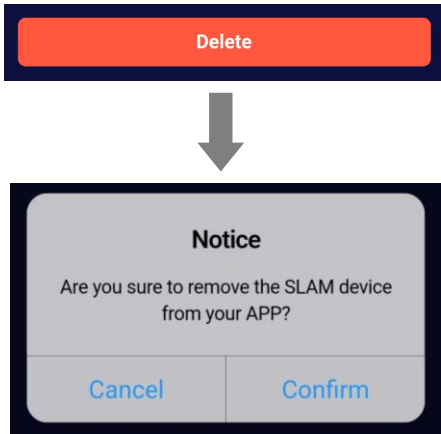

Project Management

Project List

【My Projects】 page is divided into three project lists:

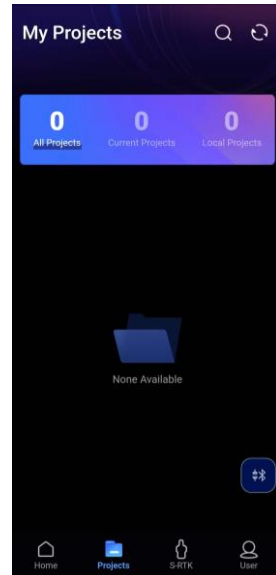

① Current Device

The projects of the current device are all the projects in the memory of the SLAM2000 device that the APP is connecting to.

② Local Projects

The projects in the Local Projects list refer to the projects to be uploaded to the cloud, which are the projects that are acquired from the SLAM2000 device to the local area of the cell phone but have not been uploaded to the cloud yet.

③ All projects

All projects include the current device projects, cloud projects, and local projects that have not been uploaded (projects that have been synchronized to APP from other SLAM2000 devices but have not yet been uploaded to the cloud).

※ **The app requires you to log in to your SLAM GO account to get the project list in the cloud platform and manage the projects.**

Project Synchronization

① Get Cloud Project List

After logging in to your SLAM GO account, click the "Synchronize" button in the upper right corner to get the list of all cloud projects.

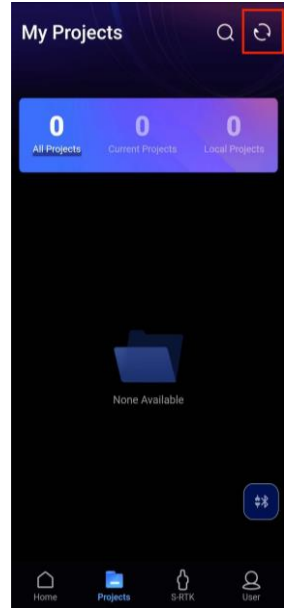

② Get the current SLAM2000 device project

Open the SLAM GO APP, connect the SLAM2000 device to WiFi, click "Home" to confirm that SLAM2000 device has been successfully connected and the status is normal, click "Project" → click the upper right corner of the "Synchronization" button. Click the "Synchronize" button, then it will start to get the project of the SALM100 device and synchronize it to the local project of the APP, please wait patiently!

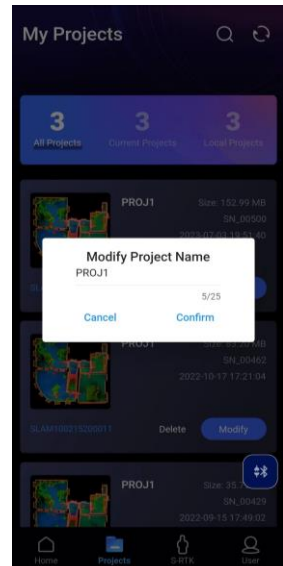

③ Synchronize SLAM2000 device projects to the cloud

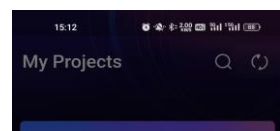

If you want to upload the project of the SLAM2000 device to the cloud archive, you need to keep the APP connected to the Internet, click the "Synchronize" button in the upper right corner, and wait for the project to be uploaded to the cloud.

Project Search

Click the "Search" button in the upper right corner, enter the trip number, project name, or project ID in the input box and click the "Confirm" button to complete the search.

Modify the Project Name

Click the **Modify** button in the item column that needs to be modified, enter the name to be modified, click the 'Confirm' button, and then click the button in the upper right corner to upload the modified item to the cloud to complete.

If you modify the project name when connecting to the SLAM2000 device, the project name in the SD card of the device will be modified synchronously.

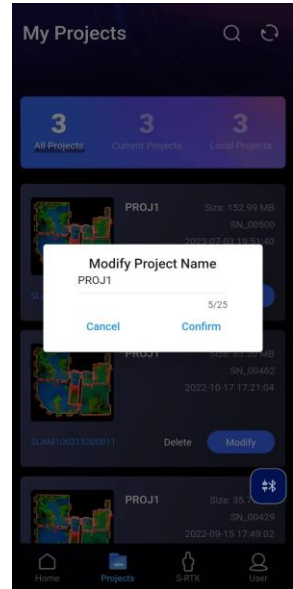

Project Deletion

Click the **Delete** button in the item column that needs to be deleted, click to confirm, and then click the button in the upper right corner to upload the deleted items to the cloud to complete.

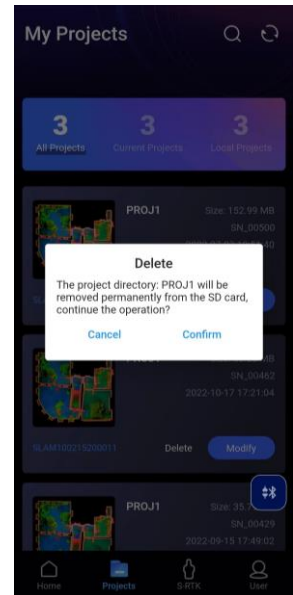

Diagnosis and Feedback

Feedback

The feedback function allows you to give feedback on problems, suggestions and comments you encountered while using the app.

Click **User** in the app, find the 'Feedback' button, click it to enter the feedback page. You can submit your questions and suggestions here and then click Confirm.

We welcome all feedback and suggestions and will review and respond as soon as possible.

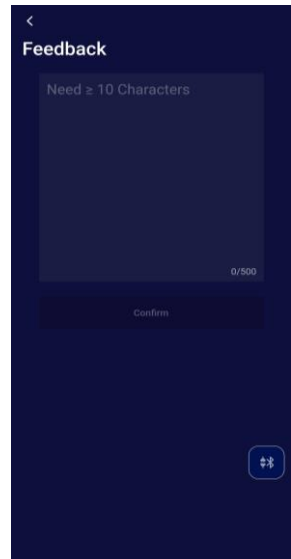

Log File Upload/Export Log

When you encounter problems with the app, you can use the log upload function. The log upload function can help us collect the problem log information of the app so that we can check the defects and problems of the app as soon as possible.

Keep the app connected to the internet, click **User** in the app, find the **Safe center** button, click the **Upload Log** button and confirm in the pop-up window, wait for the upload to finish, then the log upload will be complete.

The **Export Log** feature allows you to save application logs in your local storage so that you can send them to the Feima support team to help us better understand application issues. To use this feature, you just need to click the **Export log** button, then the app will export the log information and save it in your phone's local storage, the export path is /storage/emulated/0/Download/SLAMGO/Log/xxxxxx.zip.

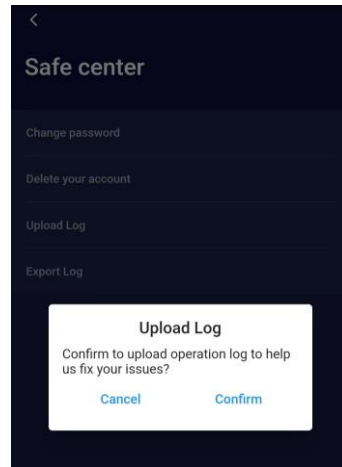
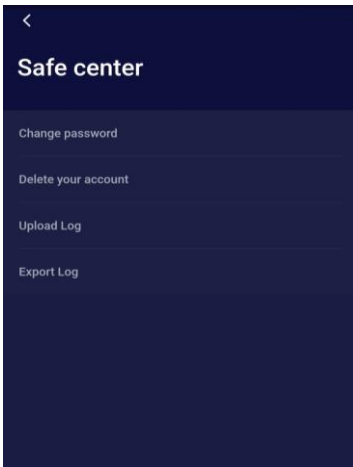

Data Collection Guidance

Site Inspection

Indoor Environment

In case of indoor environment, multi-path locations should be selected as much as possible as the starting and ending points for data collection. After the site inspection, the closed route planning for the measurement area is carried out.

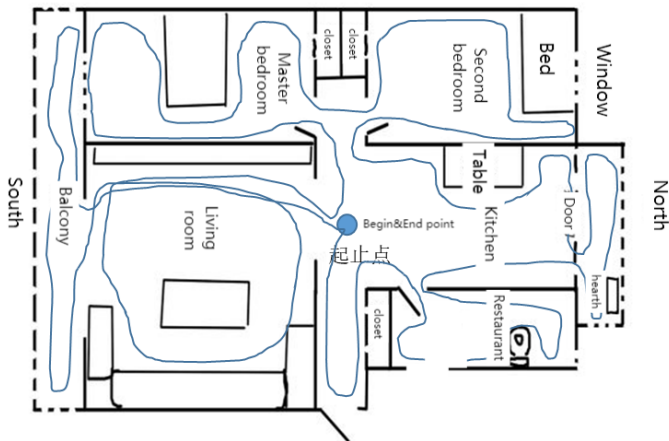
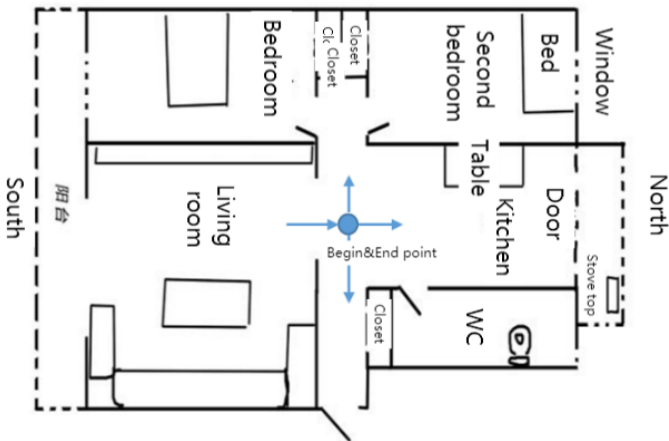

Outdoor Environment

In case of outdoor environment, in addition to finding multi-path locations and planning closed routes, it is necessary to ensure that the object under test is within the effective measurement range of the scanner (the distance varies due to different reflectivity of the ground).



Notice !

- A multi-path location is a location that can be reached from multiple directions.

Closed Loop

U-shaped Closed Route

The slender closed route is similar to a U-shaped route. The U-shaped route can barely meet the accuracy requirements. If conditions permit, users are advised not to choose this route

Single Closed O-shape Route

The trajectory shape is similar to O-shaped without redundant closed circles, and the accuracy of data calculation is good, which is one of the most basic requirements for route selection.

Multi-closed O-shaped Route

The overall trajectory is similar to O-shaped, with multiple closed circles, and the data calculation accuracy is the best. It is composed of multiple closed O-shaped routes, which greatly improves the data calculation accuracy and is the best route planning.

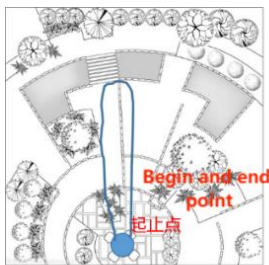

U-Type Route

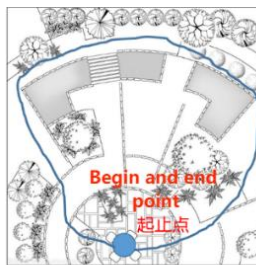

Single Close O-Type Route

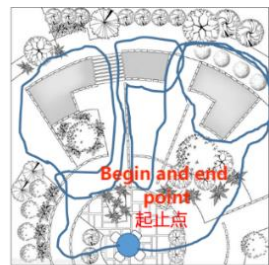

Multiple Close O-Type Route

Typical Environmental Data Collection Considerations

The SLAM2000 scanner can acquire point cloud data with the FOV of $360^{\circ} \times 270^{\circ}$, and the point density decreases with increasing measurement distance. The data acquisition process should ensure that the equipment is stable and avoid violent shaking, and avoid pedestrians, vehicles and other non-measurement objects from blocking the front of the equipment for a long time, in order to ensure the integrity of data acquisition.

Precautions When Passing through the Door

When passing through an interior door with the scanner in hand, it is recommended to pass slowly sideways to ensure the relative stability of the scanner and to ensure that the door is open as much as possible. If the door is closed, when approaching the door you need to turn the scanner back to the door and open the door with the other hand. When passing the door, you must fully consider the scanning field of view and scan as many scenes outside the door as possible in the room, try to avoid the scanner from scanning the moving door, and prevent data calculation errors.

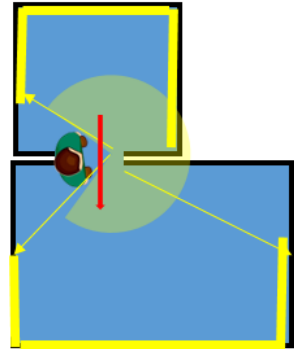

Room over the door

Precautions When Cornering

When the handheld scanner passes the corner, it is recommended to avoid turning the corner too fast, and the cornering method needs to be considered in route planning. Get as much point cloud data as possible from the same position before and after the corner to improve the data solving accuracy.

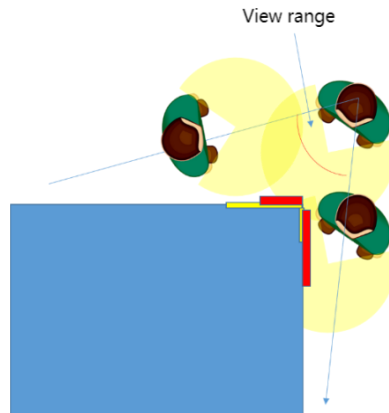

Precautions for Large-area Data Acquisition

When using the scanner for large-scale data acquisition, the overall survey area should be divided in order to facilitate data interpretation efficiency, improve interpretation accuracy and facilitate survey area management. Divide a large survey area into several small survey areas. It is recommended that the data acquisition time for each survey area planning be controlled within 25 minutes. When multiple sets of data collection need to be spliced, at least 3 common control points are required for two adjacent sets of data and they are not on a straight line.

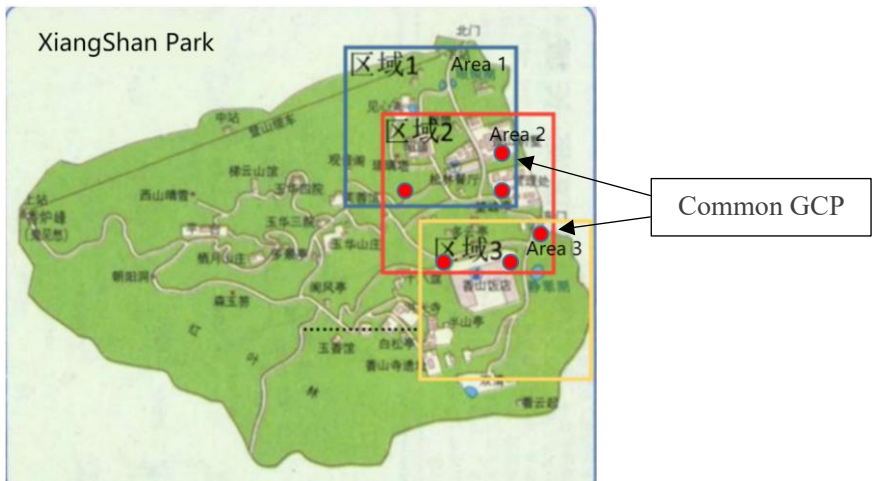

Strip Control Point Edging

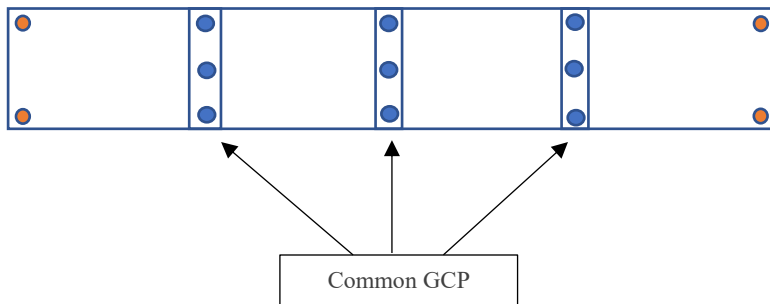

Caution

- Recommends users to press the on/off key briefly to put the scanner into standby mode after completing a single data acquisition, and then press the on/off key briefly again to start the next data acquisition.
- In principle, it is not required to take a closed-loop path, but in order to guarantee data accuracy, it is recommended that users try to take a complete closed-loop route if conditions permit.
- Please be careful when removing the scanner from the equipment case and take care to protect the rotating laser head (Precision Parts).
- Do not touch the protective cover of the laser emitting area with your hands.
- Do not touch the camera lens with your hands.
- The laser head is prohibited to be downward during data acquisition.
- Please try to keep the scanner moving smoothly during data collection and avoid violent shaking.
- Before using the device, please make sure that the battery handle is installed in place without loosening, and that the safety catch springs back into place.
- During the use of the equipment, it should be taken care of and put down gently to avoid damage to the laser due to bumping or violent vibration.
- The single data acquisition time should be more than 60 seconds.
- In order to ensure data security and data processing ease of use it is recommended that the single data acquisition time is controlled within 25 minutes.
- Keep the distance between the scanner and the object to be measured $> 0.4\text{m}$, and avoid turning the laser head towards the wall at close range ($<0.4\text{m}$).
- Try to avoid moving pedestrians in front of the laser head.
- Avoid unnecessary large turns in place.
- Data collection needs to be continuous and ensure a certain degree of overlap.

Cleaning & Maintenance

Notice!

- When cleaning the laser head protector and the camera lens can be cleaned using a clean air blow or soft dry soft bristle brush or special cleaning cloth to wipe the surface, do not use alkaline cleaners for cleaning, be careful not to be scratched by hard objects lens glass.

Storage Requirement

- Keep away from magnetic fields.
- Protect against falling.
- Prevent crushing.
- Keep away from humid environments.

If the device is not used for a long time, please store SLAM2000 in a safe, dry and ventilated place that avoids direct sunlight, the storage environment requires a relative humidity of less than 40%, and a temperature of $-20^{\circ}\text{C} \sim +60^{\circ}\text{C}$ to avoid excessive humidity in the environment that causes the device to produce condensation, and the recommended storage temperature is $+5 \sim +28^{\circ}\text{C}$.

※ This manual is subject to change without notice.

Contact Us



For more product details, please visit Cheesi Industrial Knowledge Base via the following.

If you have any questions or suggestions about the manual, please contact us via e-mail: aftersales@feimarobotics.com

This device is a handheld device.

Any Changes or modifications not expressly approved by the party responsible for compliance could void the user's authority to operate the equipment.

This device complies with part 15 of the FCC Rules. Operation is subject to the following two conditions: (1) This device may not cause harmful interference, and (2) this device must accept any interference received, including interference that may cause undesired operation.

Note: This equipment has been tested and found to comply with the limits for a Class B digital device, pursuant to part 15 of the FCC Rules. These limits are designed to provide reasonable protection against harmful interference in a residential installation. This equipment generates, uses and can radiate radio frequency energy and, if not installed and used in accordance with the instructions, may cause harmful interference to radio communications. However, there is no guarantee that interference will not occur in a particular installation. If this equipment does cause harmful interference to radio or television reception, which can be determined by turning the equipment off and on, the user is encouraged to try to correct the interference by one or more of the following measures:

- Reorient or relocate the receiving antenna.
- Increase the separation between the equipment and receiver.
- Connect the equipment into an outlet on a circuit different from that to which the receiver is connected.
- Consult the dealer or an experienced radio/TV technician for help.

This equipment complies with FCC radiation exposure limits set forth for an uncontrolled environment.

www.feimarobotics.com