

# FCC Test Report

**FCC ID** : 2A7G3XS5G01  
**Equipment** : 5G SOM  
**Model No.** : XS5G01-GBO  
(refer to item 1.1.1 for more details)  
**Brand Name** : XSquare  
**Applicant** : XSquare Communications Corporation  
**Address** : NO.6 INNOVATION ROAD II, SCIENCE PARK,  
HSINCHU 30076, TAIWAN, R.O.C  
**Standard** : 47 CFR FCC Part 96  
**Type** : End User Device  
**Received Date** : Dec. 01, 2022  
**Tested Date** : Dec. 23, 2022 ~ Feb. 09, 2023

We, International Certification Corporation, would like to declare that the tested sample has been evaluated and in compliance with the requirement of the above standards. The test results contained in this report refer exclusively to the product. It may be duplicated completely for legal use with the approval of the applicant. It shall not be reproduced except in full without the written approval of our laboratory.

Reviewed by:

Approved by:

  
\_\_\_\_\_  
Along Chen / Assistant Manager

  
\_\_\_\_\_  
Gary Chang / Manager

---

## Table of Contents

<b>1</b>	<b>GENERAL DESCRIPTION .....</b>	<b>5</b>
1.1	Information.....	5
1.2	Local Support Equipment List .....	10
1.3	Test Setup Chart .....	10
1.4	The Equipment List .....	11
1.5	Test Standards .....	12
1.6	Reference Guidance .....	12
1.7	Deviation from Test Standard and Measurement Procedure.....	12
1.8	Measurement Uncertainty .....	13
<b>2</b>	<b>TEST CONFIGURATION.....</b>	<b>14</b>
2.1	Testing Condition and Location Information.....	14
2.2	Testing Facility .....	14
2.3	The Worst Test Modes and Channel Details .....	15
<b>3</b>	<b>TEST RESULTS .....</b>	<b>16</b>
3.1	Equivalent Isotropically Radiated Power .....	16
3.2	Radiated Emissions.....	17
3.3	Conducted Emissions & Band Edge .....	19
3.4	Emission Bandwidth .....	21
3.5	Peak to Average Ratio .....	22
3.6	Frequency Stability.....	23
3.7	End user device additional requirements .....	24
<b>4</b>	<b>TEST LABORATORY INFORMATION .....</b>	<b>25</b>
	<b>APPENDIX A TEST RESULTS FOR EQUIVALENT ISOTROPICALLY RADIATED POWER</b>	
	<b>APPENDIX B TEST RESULTS FOR RADIATED EMISSIONS</b>	
	<b>APPENDIX C TEST RESULTS FOR CONDUCTED EMISSIONS &amp; BAND EDGE</b>	
	<b>APPENDIX D TEST RESULTS FOR EMISSION BANDWIDTH</b>	
	<b>APPENDIX E TEST RESULTS FOR PEAK TO AVERAGE POWER RATIO</b>	
	<b>APPENDIX F TEST RESULTS FOR FREQUENCY STABILITY</b>	
	<b>APPENDIX G TEST RESULTS FOR END USER DEVICE ADDITIONAL REQUIREMENTS</b>	

---

## Release Record

Report No.	Version	Description	Issued Date
FG132502-04P96	Rev. 01	Initial issue	Apr. 18, 2023

## Summary of Test Results

FCC Rules	Test Items	Measured	Result
2.1046 / 96.41(b)	Equivalent Isotropically Radiated Power	Power[dBm]: 22.49	Pass
96.41(g)	Peak to Average Ratio	Meet the requirement of limit	Pass
2.1053 / 96.41(e)	Radiated Spurious Emission	Meet the requirement of limit	Pass
2.1051 / 96.41(e)	Conducted Spurious Emission	Meet the requirement of limit	Pass
2.1051 / 96.41(e)	Band Edge	Meet the requirement of limit	Pass
2.1049	Emission Bandwidth	Meet the requirement of limit	Pass
2.1055 / 96.41(e)	Frequency Stability	Meet the requirement of limit	Pass
96.47	End user device additional requirements	Meet the requirement of limit	Pass

### Declaration of Conformity:

The test results with all measurement uncertainty excluded are presented in accordance with the regulation limits or requirements declared by manufacturers.

### Comments and Explanations:

The declared of product specification for EUT presented in the report are provided by the manufacturer, and the manufacturer takes all the responsibilities for the accuracy of product specification.

# 1 General Description

## 1.1 Information

### 1.1.1 Product Details

The following models are provided to this EUT.

Brand Name	Model Name	Product Name	Description
XSquare	XS5G01-GBO	5G SOM	With GPS Component
	XS5G01-GBI		Without GPS Component
† The above models, model <b>XS5G01-GBO</b> was selected as a representative one for the final test and only its data was recorded in this report.			

### 1.1.2 Specification of the Equipment under Test (EUT)

<b>Operating Band</b>	LTE Band 42: Channel Bandwidth: 5MHz: 3552.5 MHz ~ 3597.5 MHz Channel Bandwidth: 10MHz: 3555.0 MHz ~ 3595.0 MHz Channel Bandwidth: 15MHz: 3557.5 MHz ~ 3592.5 MHz Channel Bandwidth: 20MHz: 3560.0 MHz ~ 3590.0 MHz LTE Band 43: Channel Bandwidth: 5MHz: 3602.5 MHz ~ 3697.5 MHz Channel Bandwidth: 10MHz: 3605.0 MHz ~ 3695.0 MHz Channel Bandwidth: 15MHz: 3607.5 MHz ~ 3692.5 MHz Channel Bandwidth: 20MHz: 3610.0 MHz ~ 3690.0 MHz LTE Band 48: Channel Bandwidth: 5MHz: 3552.5 MHz ~ 3697.5 MHz Channel Bandwidth: 10MHz: 3555.0 MHz ~ 3695.0 MHz Channel Bandwidth: 15MHz: 3557.5 MHz ~ 3692.5 MHz Channel Bandwidth: 20MHz: 3560.0 MHz ~ 3690.0 MHz
<b>Modulation</b>	QPSK, 16QAM, 64QAM, 256QAM (Uplink) QPSK, 16QAM, 64QAM, 256QAM (Downlink)
<b>Uplink CA Band</b>	13A-48A

### 1.1.3 Antenna Details

Brand	Model	Type	Connector	Gain (dBi)
Anjie	AELQ2S-B066L	Dipole	SMA	-0.4

### 1.1.4 EUT Operational Condition

<b>Supply Voltage</b>	4 Vdc		
<b>Operational Voltage</b>	<input checked="" type="checkbox"/> Vnom (4 V)	<input checked="" type="checkbox"/> Vmax (4.2 V)	<input checked="" type="checkbox"/> Vmin (3.8 V)
<b>Operational Climatic</b>	<input checked="" type="checkbox"/> Tnom (20°C)	<input checked="" type="checkbox"/> Tmax (70°C)	<input checked="" type="checkbox"/> Tmin (-30°C)

### 1.1.5 Accessories

N/A

### 1.1.6 Maximum Conducted Power and Emission Designator

LTE Band 42			
Channel Bandwidth (MHz)	Modulation	Maximum Conducted Power (W)	Emission Designator
5	QPSK	0.187	4M47G7D
5	16QAM	0.147	4M46W7D
5	64QAM	0.116	4M48W7D
5	256QAM	0.065	4M45W7D
10	QPSK	0.187	8M91G7D
10	16QAM	0.147	8M92W7D
10	64QAM	0.117	8M96W7D
10	256QAM	0.065	8M91W7D
15	QPSK	0.188	13M4G7D
15	16QAM	0.149	13M4W7D
15	64QAM	0.120	13M4W7D
15	256QAM	0.066	13M4W7D
20	QPSK	0.189	17M9G7D
20	16QAM	0.151	17M9W7D
20	64QAM	0.122	17M9W7D
20	256QAM	0.065	17M9W7D

LTE Band 43			
Channel Bandwidth (MHz)	Modulation	Maximum Conducted Power (W)	Emission Designator
5	QPSK	0.186	4M47G7D
5	16QAM	0.146	4M46W7D
5	64QAM	0.117	4M48W7D
5	256QAM	0.065	4M45W7D
10	QPSK	0.186	8M91G7D
10	16QAM	0.145	8M92W7D
10	64QAM	0.118	8M96W7D
10	256QAM	0.066	8M91W7D
15	QPSK	0.187	13M4G7D
15	16QAM	0.147	13M4W7D
15	64QAM	0.119	13M4W7D
15	256QAM	0.066	13M4W7D
20	QPSK	0.187	17M9G7D
20	16QAM	0.151	17M9W7D
20	64QAM	0.119	17M9W7D
20	256QAM	0.066	17M9W7D

LTE Band 48			
Channel Bandwidth (MHz)	Modulation	Maximum Conducted Power (W)	Emission Designator
5	QPSK	0.189	4M47G7D
5	16QAM	0.151	4M46W7D
5	64QAM	0.119	4M48W7D
5	256QAM	0.066	4M45W7D
10	QPSK	0.189	8M91G7D
10	16QAM	0.151	8M92W7D
10	64QAM	0.119	8M96W7D
10	256QAM	0.066	8M91W7D
15	QPSK	0.189	13M4G7D
15	16QAM	0.151	13M4W7D
15	64QAM	0.119	13M4W7D
15	256QAM	0.067	13M4W7D
20	QPSK	0.195	17M9G7D
20	16QAM	0.152	17M9W7D
20	64QAM	0.122	17M9W7D
20	256QAM	0.067	17M9W7D

### 1.1.7 Operating Channel List

LTE Band 42		
Channel Bandwidth (MHz)	Channel	Frequency (MHz)
5	43115	3552.5
5	43340	3575
5	43565	3597.5
10	43140	3555
10	43340	3575
10	43540	3595
15	43165	3557.5
15	43340	3575
15	43515	3592.5
20	43190	3560
20	43340	3575
20	43490	3590



LTE Band 43		
Channel Bandwidth (MHz)	Channel	Frequency (MHz)
5	43615	3602.5
5	44090	3650
5	44545	3697.5
10	43640	3605
10	44090	3650
10	44540	3695
15	43665	3607.5
15	44090	3650
15	44515	3692.5
20	43690	3610
20	44090	3650
20	44490	3690

LTE Band 48		
Channel Bandwidth (MHz)	Channel	Frequency (MHz)
5	55265	3552.5
5	55990	3625.0
5	56715	3697.5
10	55290	3555.0
10	55990	3625.0
10	56690	3695.0
15	55315	3557.5
15	55990	3625.0
15	56665	3692.5
20	55340	3560.0
20	55990	3625.0
20	56640	3690.0

## 1.2 Local Support Equipment List

Support Equipment List					
No.	Equipment	Brand	Model	FCC ID	Remarks
1	Adapter	APD	WY-36C12FU	---	Provided by applicant.

## 1.3 Test Setup Chart

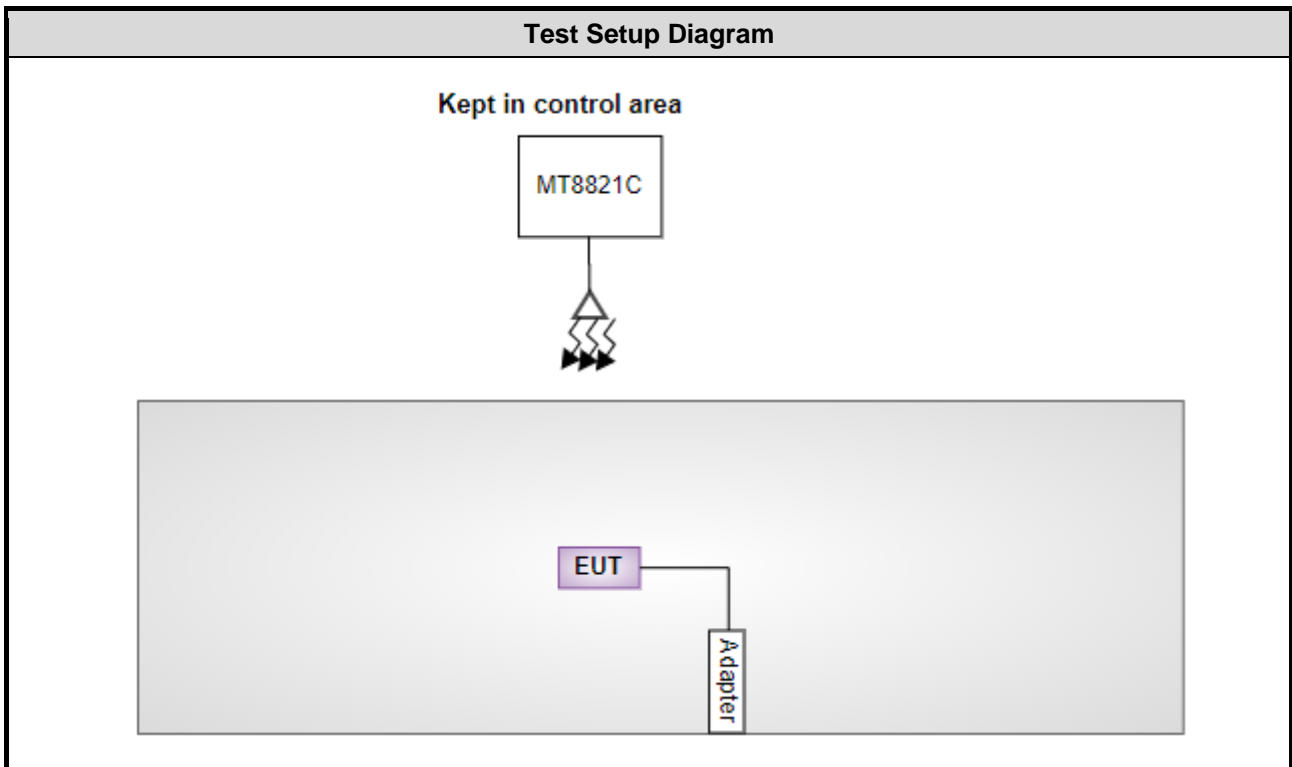

## 1.4 The Equipment List

Test Item	Radiated Emission				
Test Site	966 chamber1 / (03CH01-WS)				
Tested Date	Feb. 06 ~ Feb. 09, 2023				
Instrument	Brand	Model No.	Serial No.	Calibration Date	Calibration Until
Receiver	R&S	ESR3	101657	Mar. 15, 2022	Mar. 14, 2023
Spectrum Analyzer	R&S	FSV40	101498	Nov. 21, 2022	Nov. 20, 2023
Loop Antenna	R&S	HFH2-Z2	100330	Nov. 01, 2022	Oct. 31, 2023
Bilog Antenna	SCHWARZBECK	VULB9168	VULB9168-522	Aug. 03, 2022	Aug. 02, 2023
Horn Antenna 1G-18G	SCHWARZBECK	BBHA 9120 D	BBHA 9120 D 1096	Nov. 25, 2022	Nov. 24, 2023
Horn Antenna 18G-40G	SCHWARZBECK	BBHA 9170	BBHA 9170517	Oct. 27, 2022	Oct. 26, 2023
Preamplifier	EMC	EMC02325	980225	Jun. 28, 2022	Jun. 27, 2023
Preamplifier	EMC	EMC118A45SE	980898	Jul. 16, 2022	Jul. 15, 2023
Preamplifier	EMC	EMC184045SE	980903	Jul. 16, 2022	Jul. 15, 2023
Loop Antenna Cable	KOAX KABEL	101354-BW	101354-BW	Oct. 04, 2022	Oct. 03, 2023
LF cable 3M	Woken	CFD400NL-LW	CFD400NL-001	Oct. 04, 2022	Oct. 03, 2023
LF cable 11M	EMC	EMCCFD400-NW-N W-11000	200801	Oct. 04, 2022	Oct. 03, 2023
LF cable 1M	EMC	EMCCFD400-NM-N M-1000	160502	Oct. 04, 2022	Oct. 03, 2023
RF Cable	EMC	EMC104-35M-35M- 8000	210920	Oct. 04, 2022	Oct. 03, 2023
RF Cable	HUBER+SUHNER	SUCOFLEX104	MY16019/4	Oct. 04, 2022	Oct. 03, 2023
Measurement Software	AUDIX	e3	6.120210g	NA	NA
Radio Communication Analyzer	Anritsu	MT8821C	6262149999	Sep. 12, 2022	Sep. 11, 2023

Note: Calibration Interval of instruments listed above is one year.

<b>Test Item</b>	RF Conducted				
<b>Test Site</b>	(TH01-WS)				
<b>Tested Date</b>	Dec. 23, 2022 ~ Feb. 09, 2023				
<b>Instrument</b>	<b>Brand</b>	<b>Model No.</b>	<b>Serial No.</b>	<b>Calibration Date</b>	<b>Calibration Until</b>
Spectrum Analyzer	R&S	FSV40	101910	Apr. 08, 2022	Apr. 07, 2023
Spectrum Analyzer	Keysight	N9010A	MY54510374	Aug. 26, 2022	Aug. 25, 2023
Power Meter	Anritsu	ML2495A	1241002	Nov. 23, 2022	Nov. 22, 2023
Power Sensor	Anritsu	MA2411B	1207366	Nov. 23, 2022	Nov. 22, 2023
TEMP&HUMIDITY CHAMBER	GIANT FORCE	GCT-225-40-SP-SD	MAF1212-002	Jun. 22, 2022	Jun. 21, 2023
DC POWER SOURCE	GW INSTRON	GPC-6030D	GES855395	Oct. 31, 2022	Oct. 30, 2023
Measurement Software	Sporton	SENSE-FCC_2G-4 G	V6.1.6	NA	NA
Radio Communication Analyzer	Anritsu	MT8821C	6262149999	Sep. 12, 2022	Sep. 11, 2023
Note: Calibration Interval of instruments listed above is one year.					

## 1.5 Test Standards

47 CFR FCC Part 96  
ANSI C63.26-2015  
FCC KDB 971168 D01 Power Meas License Digital Systems v03r01

## 1.6 Reference Guidance

ANSI C63.4-2014  
FCC KDB 412172 D01 Determining ERP and EIRP v01r01

## 1.7 Deviation from Test Standard and Measurement Procedure

None

## 1.8 Measurement Uncertainty

The measurement uncertainties given below are based on a 95% confidence level (based on a coverage factor (k=2)).

Measurement Uncertainty	
Parameters	Uncertainty
Bandwidth	$\pm 34.130$ Hz
Conducted power	$\pm 0.808$ dB
Frequency error	$\pm 1 \times 10^{-9}$
Conducted emission	$\pm 2.715$ dB
Radiated emission $\leq 1$ GHz	$\pm 3.41$ dB
Radiated emission $> 1$ GHz	$\pm 4.59$ dB
Temperature	$\pm 0.4$ °C

## 2 Test Configuration

### 2.1 Testing Condition and Location Information

Test Item	Test Site	Ambient Condition	Tested By
Radiated Emissions	03CH01-WS	23-24°C / 65-66%	Brad Wu
RF Conducted	TH01-WS	23-25°C / 62-66%	Aska Huang

- FCC Designation No.: TW2732
- FCC site registration No.: 181692
- ISED#: 10807A
- CAB identifier: TW2732

### 2.2 Testing Facility

Test Laboratory	International Certification Corporation
Test Site	03CH01-WS, TH01-WS
Address of Test Site	No.3-1, Lane 6, Wen San 3rd St., Kwei Shan Dist., Tao Yuan City 33381, Taiwan (R.O.C.)

## 2.3 The Worst Test Modes and Channel Details

Test items	Band	Bandwidth(MHz)						Modulation				RB#			Test Channel			
		1.4	3	5	10	15	20	QPSK	16 QAM	64 QAM	256 QAM	1	Half	Full	L	M	H	
Max. Output Power	42	-	-	v	v	v	v	v	v	v	v	v	v	v	v	v	v	
	43	-	-	v	v	v	v	v	v	v	v	v	v	v	v	v	v	
	48	-	-	v	v	v	v	v	v	v	v	v	v	v	v	v	v	
peak-to-Average Ratio	42	Covered by LTE Band48																
	43	Covered by LTE Band48																
	48	-	-				v	v	v	v	v			v		v		
26dB and 99% Bandwidth	42	Covered by LTE Band48																
	43	Covered by LTE Band48																
	48	-	-	v	v	v	v	v	v	v	v	v			v		v	
Conducted Band edge	42	Covered by LTE Band48																
	43	Covered by LTE Band48																
	48	-	-	v	v	v	v	v	v	v	v	v	v		v	v	v	
Conducted Spurious Emission	42	Covered by LTE Band48																
	43	Covered by LTE Band48																
	48	-	-	v	v	v	v	v	v				v			v	v	v
Frequency Stability	42	Covered by LTE Band48																
	43	Covered by LTE Band48																
	48	-	-				v	v							v		v	
E.I.R.P	42	-	-	v	v	v	v	v	v	v	v		Max. power					
	43	-	-	v	v	v	v	v	v	v	v							
	48	-	-	v	v	v	v	v	v	v	v							
Radiated Spurious Emission	42	Covered by LTE Band48													v	v	v	
	43	Covered by LTE Band48													v	v	v	
	48	Worst Case													v	v	v	
Remark	<p>1. "v": this configuration is for testing.  2. "-": This bandwidth is not supported.  3. Frequency range of radiated measurement is from 30 MHz to 10th harmonic of fundamental frequency.  4. All spurious emissions below 1000 MHz are more than 20 dB below the limit.  5. The EUT was pretested with 3 orientations placed on the table for the radiated emission measurement – X, Y, and Z-plane. The Z-plane results were found as the worst case and were shown in this report.</p>																	

### 3 Test Results

#### 3.1 Equivalent Isotropically Radiated Power

##### 3.1.1 Limit of Equivalent Isotropically Radiated Power

Device	Maximum EIRP (dBm/10MHz)	Maximum PSD (dBm/MHz)
End User Device	23	n/a

##### 3.1.2 Test Procedures

###### For E.I.R.P measurement

ERP can be calculated by below formula from KDB 412172 D01.

$$1. \quad EIRP = P_T + G_T - L_C$$

$P_T$  = transmitter output power, in dBm.

$G_T$  = gain of the transmitting antenna, in dBi (EIRP).

$L_C$  = signal attenuation in the connecting cable between the transmitter and antenna, in dB.

###### For Conducted power measurement

1. The EUT links up with simulator and is set to maximum output power level at low / middle / high channel.
2. Measure the output power of low / middle / high channel of the EUT

##### 3.1.3 Test Setup

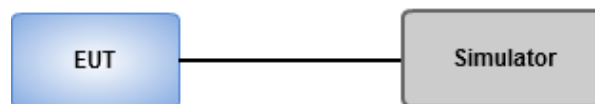

##### 3.1.4 Test Result

Refer to Appendix A.1, A.2, A.3



## 3.2 Radiated Emissions

### 3.2.1 Limit of Radiated Emissions

The conducted power of any End User Device emission outside the fundamental emission (whether in or outside of the authorized band) shall not exceed  $-13$  dBm/MHz within 0 to B megahertz (where B is the bandwidth in megahertz of the assigned channel or multiple contiguous channels of the End User Device) above the upper CBSD-assigned channel edge and within 0 to B megahertz below the lower CBSD-assigned channel edge. At all frequencies greater than B megahertz above the upper CBSD assigned channel edge and less than B megahertz below the lower CBSD-assigned channel edge, the conducted power of any End User Device emission shall not exceed  $-25$  dBm/MHz. Notwithstanding the emission limits in this paragraph, the Adjacent Channel Leakage Ratio for End User Devices shall be at least 30 dB.

### 3.2.2 Test Procedures

1. Measurement is made at a semi-anechoic chamber that incorporates a turntable allowing a EUT rotation of  $360^\circ$ . A continuously-rotating, remotely-controlled turntable is installed at the test site to support the EUT and facilitate determination of the direction of maximum radiation for each EUT emission frequency. For emissions testing at or below 1 GHz, the table height is 80 cm above the reference ground plane. For emission measurements above 1 GHz, the table height is 1.5 m.
2. Measurement is made with the antenna positioned in both the horizontal and vertical planes of polarization. The measurement antenna is varied in height (1m ~ 4m) above the reference ground plane to obtain the maximum signal strength. Distance between EUT and antenna is 3 m.
3. This investigation is performed with the EUT rotated  $360^\circ$ , the antenna height scanned between 1 m and 4 m, and the antenna rotated to repeat the measurements for both the horizontal and vertical antenna polarizations.
4. After finding the max radiated emission, substitution method will be used for getting effective radiated power. EUT will be removed and substitution antenna will be placed at same position. Signal generator will output CW signal to substitution antenna through a RF cable. Rotate turntable and move antenna to find maximum radiated emission. Adjust output power of signal generator to let the maximum radiated emission is same as step 3. Record the output power level.
5. E.I.R.P = output power of step 4 + gain of substitution antenna – cable loss of RF cable. ERP can be calculated by below formula:

### 3.2.3 Test Setup

#### Radiated Emissions below 1 GHz

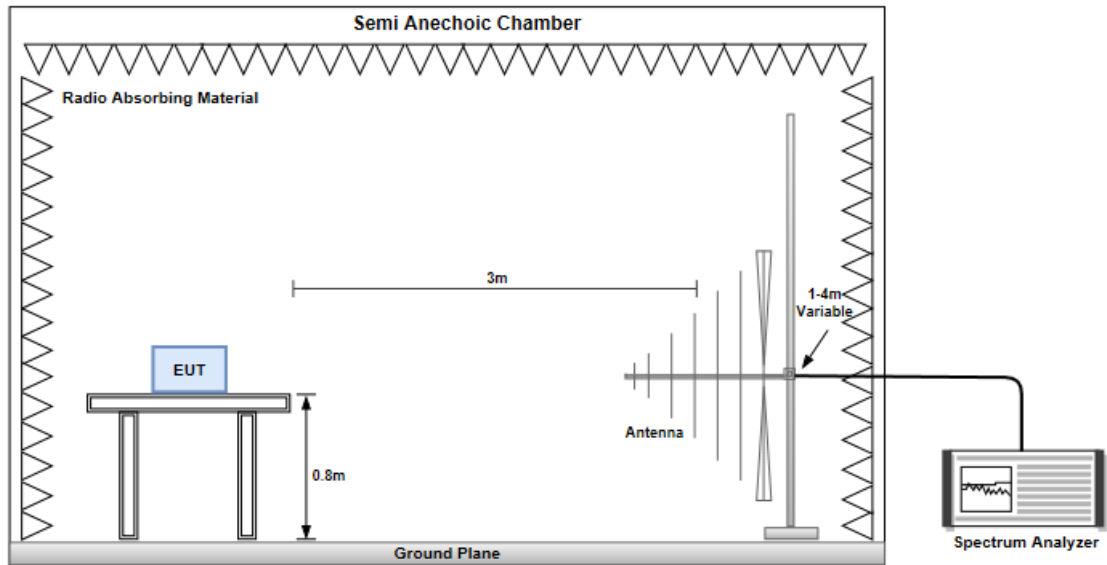

#### Radiated Emissions above 1 GHz

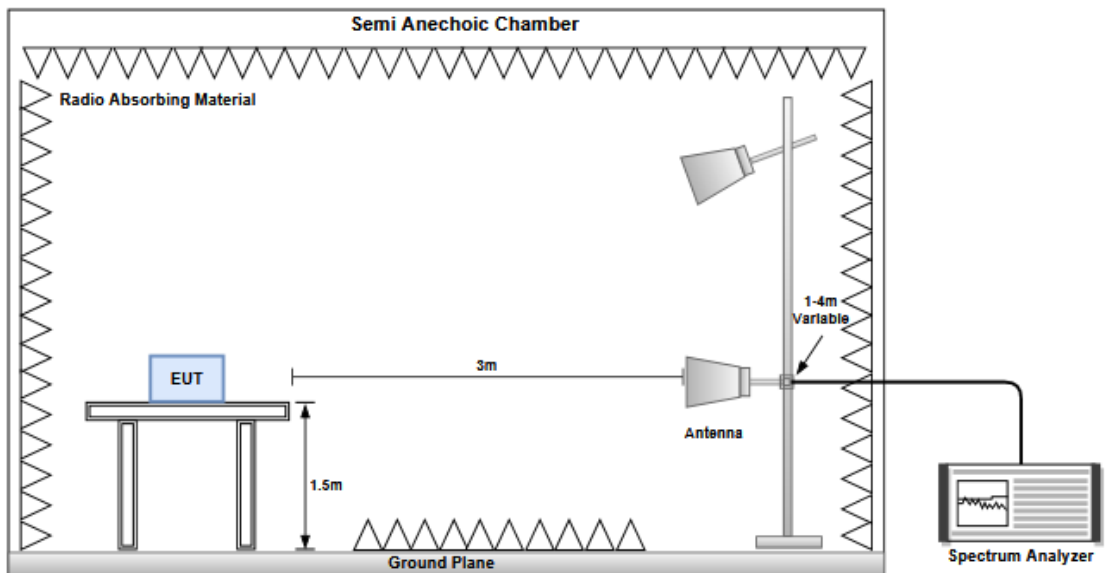

### 3.2.4 Test Result

Refer to Appendix B.1.

### 3.3 Conducted Emissions & Band Edge

#### 3.3.1 Limit of Conducted Emissions & Band Edge

The conducted power of any End User Device emission outside the fundamental emission (whether in or outside of the authorized band) shall not exceed  $-13$  dBm/MHz within  $0$  to  $B$  megahertz (where  $B$  is the bandwidth in megahertz of the assigned channel or multiple contiguous channels of the End User Device) above the upper CBSD-assigned channel edge and within  $0$  to  $B$  megahertz below the lower CBSD-assigned channel edge. At all frequencies greater than  $B$  megahertz above the upper CBSD assigned channel edge and less than  $B$  megahertz below the lower CBSD-assigned channel edge, the conducted power of any End User Device emission shall not exceed  $-25$  dBm/MHz. Notwithstanding the emission limits in this paragraph, the Adjacent Channel Leakage Ratio for End User Devices shall be at least  $30$  dB.

Emissions below  $3540$  MHz or above  $3710$  MHz shall not exceed  $-25$  dBm/MHz, and the conducted power of emissions below  $3530$  MHz or above  $3720$  MHz shall not exceed  $-40$  dBm/MHz

#### 3.3.2 Test Procedures

Emission below  $3530$  MHz / Emission above  $3720$  MHz

1. Lowest, middle and highest operating channels are tested for this item.
2. Scan frequency range is from  $30$  MHz ~  $37$  GHz.
3. Set RBW =  $1$  MHz, VBW =  $3$  MHz, detector = RMS, sweep time = auto.
4. Record the max trace value and capture the test plot of each sub frequency band.

$3530$  MHz ~  $(F_c - BW/2) / (F_c + BW/2)$  ~  $3720$  MHz

1. Lowest /middle / highest operating channels are tested for this item.
2. The center frequency of spectrum analyzer will be set to Lowest /middle / highest operating channels.
3. Set RBW =  $100$  kHz, VBW =  $300$  kHz, detector = RMS, sweep time = auto.
4. Using channel power function to measure test result and record the max trace value and capture the test plot.

Adjacent Channel Leakage Ratio

1. Lowest /middle / highest operating channels are tested for this item.
2. The center frequency of spectrum analyzer will be set to Lowest /middle / highest operating channels.
3. Set RBW= $50$  kHz, VBW= $200$  kHz, detector = RMS, sweep time = auto for  $5$  MHz channel bandwidth
4. Set RBW= $100$  kHz, VBW= $300$  kHz, detector = RMS, sweep time = auto for  $10$  MHz channel bandwidth
5. Set RBW= $200$  kHz, VBW= $1000$  kHz, detector = RMS, sweep time = auto for  $15/20$  MHz channel bandwidth
6. Using Adjacent channel power function to measure test result and capture the test plot.

### 3.3.3 Test Setup

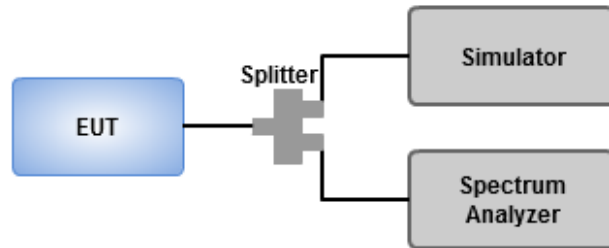

### 3.3.4 Test Result

Refer to Appendix C.1.

## 3.4 Emission Bandwidth

### 3.4.1 Test Procedures

1. Set resolution bandwidth (RBW) = 100 kHz, Video bandwidth = 300 kHz for CB: 10MHz.  
Set resolution bandwidth (RBW) = 200 kHz, Video bandwidth = 1 MHz for CB: 20MHz.
2. Detector = Peak, Trace mode = max hold.
3. Sweep = auto couple, Allow the trace to stabilize.
4. Measure the maximum width of the emission that is constrained by the frequencies associated with the two outermost amplitude points (upper and lower) that are attenuated by 26dB relative to the maximum level measured in the fundamental emission.
5. Measure the occupied bandwidth.

### 3.4.2 Test Setup

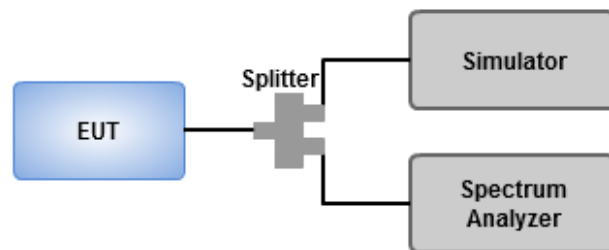

### 3.4.3 Test Result

Refer to Appendix D.1.

## 3.5 Peak to Average Ratio

### 3.5.1 Limit of Peak to Average Ratio

Peak-to-average ratio (PAR) of the transmission may not exceed 13 dB

### 3.5.2 Test Procedures

1. Enable CCDF function of spectrum analyzer and set RBW=10MHz.
2. Set the number of counts to a value that stabilizes the measured CCDF curve.
3. Record the maximum PAPR level associated with a probability of 0.1%.

### 3.5.3 Test Setup

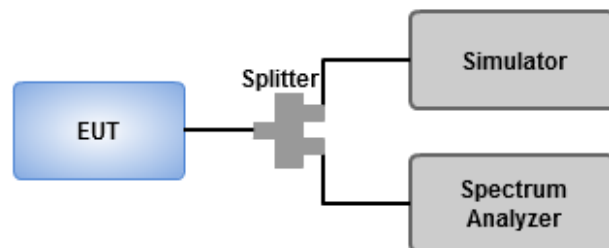

### 3.5.4 Test Result

Refer to Appendix E.1.

## 3.6 Frequency Stability

### 3.6.1 Limit of Frequency Stability

The frequency stability shall be sufficient to ensure that the fundamental emissions stay within the authorized bands of operation

### 3.6.2 Test Procedures

1. EUT was placed at temperature chamber and connected to an external power supply.
2. Temperature and voltage condition shall be tested to confirm frequency stability.
3. Temperature range is from -30 ~ 70 °C and voltage range is from lowest to highest working voltage.
4. Tem Link up EUT and simulator. Confirm frequency drift value of simulator and record it.

### 3.6.3 Test Setup

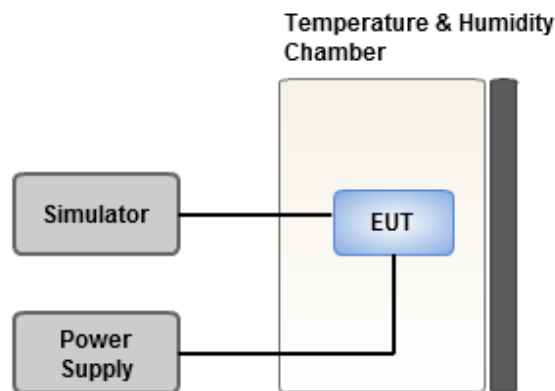

### 3.6.4 Test Result

Refer to Appendix F.1.

## 3.7 End user device additional requirements

### 3.7.1 Description of End user device additional requirements

- (a) End User Devices may operate only if they can positively receive and decode an authorization signal transmitted by a CBSD, including the frequencies and power limits for their operation
- (1) An End User Device must discontinue operations, change frequencies, or change its operational power level within 10 seconds of receiving instructions from its associated CBSD.

### 3.7.2 Test Procedures

1. Set companion device(certified CBSD, FCC ID: S9GQ710US02) with 3600 ~ 3620 MHz and Power level 20 dBm/MHz
2. Enable AP service and check EUD TX frequency and power
3. Disable AP service and check EUD stop transmission within 10s
4. Set companion device(certified CBSD, FCC ID: S9GQ710US02) with 3670 ~ 3690 MHz and Power level 10 dBm/MHz
5. Enable AP service and check EUD TX frequency and power
6. Disable AP service and check EUD stop transmission within 10s

### 3.7.3 Test Setup

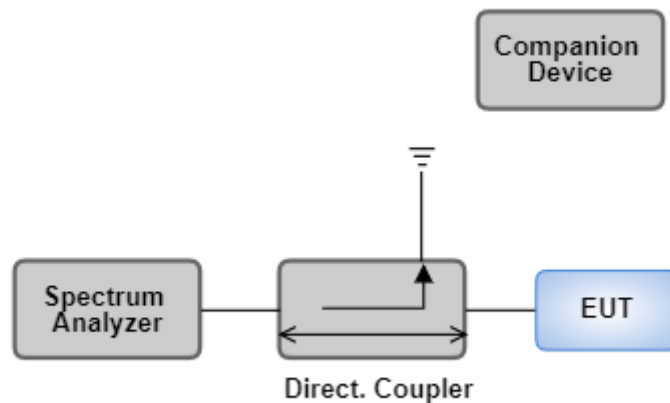

Note: Companion device is a certified CBSD, FCC ID: S9GQ710US02

### 3.7.4 Test Result

Refer to Appendix G.1.



## 4 Test laboratory information

Established in 2012, ICC provides foremost EMC & RF Testing and advisory consultation services by our skilled engineers and technicians. Our services employ a wide variety of advanced edge test equipment and one of the widest certification extents in the business.

International Certification Corporation (EMC and Wireless Communication Laboratory), it is our definitive objective is to institute long term, trust-based associations with our clients. The expectation we set up with our clients is based on outstanding service, practical expertise and devotion to a certified value structure. Our passion is to grant our clients with best EMC / RF services by oriented knowledgeable and accommodating staff.

Our Test sites are located at Linkou District and Kwei Shan District. Location map can be found on our website <http://www.icertifi.com.tw>.

### **Linkou**

Tel: 886-2-2601-1640

No.30-2, Ding Fwu Tsuen, Lin Kou  
District, New Taipei City, Taiwan  
(R.O.C.)

### **Kwei Shan**

Tel: 886-3-271-8666

No.3-1, Lane 6, Wen San 3rd  
St., Kwei Shan Dist., Tao Yuan  
City 33381, Taiwan (R.O.C.)  
No.2-1, Lane 6, Wen San 3rd  
St., Kwei Shan Dist., Tao Yuan  
City 33381, Taiwan (R.O.C.)

### **Kwei Shan Site II**

Tel: 886-3-271-8640

No.14-1, Lane 19, Wen San 3rd  
St., Kwei Shan Dist., Tao Yuan  
City 33381, Taiwan (R.O.C.)

If you have any suggestion, please feel free to contact us as below information.

Tel: 886-3-271-8666

Fax: 886-3-318-0345

Email: ICC\_Service@icertifi.com.tw

==END==



Summary

Part96 LTE Band 48 MaxiMum Average Power [dBm](GT-LC= -0.4 dB)								
BW (MHz)	Modulation	RB Size	RB Offset	Lowest	Middle	Highest	EIRP (dBm)	EIRP (W)
Channel				55340	55990	56640		
Frequency				3560	3625	3690		
20	QPSK	1	0	22.71	22.74	22.89	22.49	0.1774
20	QPSK	1	99	22.63	22.72	22.77		
20	QPSK	100	0	21.68	21.84	21.75		
20	16QAM	1	0	21.65	21.82	21.76	21.42	0.1387
20	64QAM	1	0	20.69	20.85	20.78	20.45	0.1109
20	256QAM	1	0	18.03	18.27	18.16	17.87	0.0612
Channel				55315	55990	56665	EIRP (dBm)	EIRP (W)
Frequency				3557.5	3625	3692.5		
15	QPSK	1	0	22.65	22.76	22.74	22.36	0.1722
15	QPSK	1	74	22.63	22.72	22.71		
15	QPSK	75	0	21.65	21.81	21.71		
15	16QAM	1	0	21.62	21.79	21.73	21.39	0.1377
15	64QAM	1	0	20.68	20.77	20.68	20.37	0.1089
15	256QAM	1	0	18.01	18.25	18.12	17.85	0.0610
Channel				55290	55990	56690	EIRP (dBm)	EIRP (W)
Frequency				3555	3625	3695		
10	QPSK	1	0	22.62	22.77	22.73	22.37	0.1726
10	QPSK	1	49	22.61	22.75	22.71		
10	QPSK	50	0	21.63	21.79	21.69		
10	16QAM	1	0	21.64	21.78	21.72	21.38	0.1374
10	64QAM	1	0	20.66	20.75	20.73	20.35	0.1084
10	256QAM	1	0	18.05	18.22	18.18	17.82	0.0605
Channel				55265	55990	56715	EIRP (dBm)	EIRP (W)
Frequency				3552.5	3625	3697.5		
5	QPSK	1	0	22.62	22.77	22.73	22.37	0.1726
5	QPSK	1	24	22.61	22.75	22.71		
5	QPSK	25	0	21.63	21.79	21.69		
5	16QAM	1	0	21.64	21.78	21.72	21.38	0.1374
5	64QAM	1	0	20.66	20.75	20.73	20.35	0.1084
5	256QAM	1	0	18.05	18.22	18.18	17.82	0.0605
Limit	EIRP < 23 dBm/10MHz			Result			Pass	

Remark: Total channel power is complied with EIRP limit 23dBm/10MHz.



Summary

Part96 LTE Band 42 MaxiMum Average Power [dBm](GT-LC= -0.4 dB)								
BW (MHz)	Modulation	RB Size	RB Offset	Lowest	Middle	Highest	EIRP (dBm)	EIRP (W)
Channel				43190	43340	43490		
Frequency				3560	3575	3590		
20	QPSK	1	0	22.65	22.72	22.76	22.36	0.1722
20	QPSK	1	99	22.64	22.68	22.73		
20	QPSK	100	0	21.67	21.74	21.81		
20	16QAM	1	0	21.78	21.61	21.69	21.38	0.1374
20	64QAM	1	0	20.87	20.72	20.75	20.47	0.1114
20	256QAM	1	0	18.11	18.16	18.15	17.76	0.0597
Channel				43165	43340	43515	EIRP (dBm)	EIRP (W)
Frequency				3557.5	3575	3592.5		
15	QPSK	1	0	22.62	22.73	22.74	22.34	0.1714
15	QPSK	1	74	22.61	22.71	22.71		
15	QPSK	75	0	21.65	21.72	21.79		
15	16QAM	1	0	21.72	21.63	21.62	21.32	0.1355
15	64QAM	1	0	20.79	20.72	20.72	20.39	0.1094
15	256QAM	1	0	18.05	18.18	18.14	17.78	0.0600
Channel				43140	43340	43540	EIRP (dBm)	EIRP (W)
Frequency				3555	3575	3595		
10	QPSK	1	0	22.65	22.71	22.73	22.33	0.1710
10	QPSK	1	49	22.62	22.69	22.72		
10	QPSK	50	0	21.61	21.68	21.76		
10	16QAM	1	0	21.68	21.65	21.68	21.28	0.1343
10	64QAM	1	0	20.69	20.66	20.69	20.29	0.1069
10	256QAM	1	0	18.02	18.15	18.13	17.75	0.0596
Channel				43115	43340	43565	EIRP (dBm)	EIRP (W)
Frequency				3552.5	3575	3597.5		
5	QPSK	1	0	22.67	22.68	22.72	22.32	0.1706
5	QPSK	1	24	22.63	22.67	22.7		
5	QPSK	25	0	21.65	21.65	21.73		
5	16QAM	1	0	21.63	21.62	21.66	21.26	0.1337
5	64QAM	1	0	20.65	20.62	20.65	20.25	0.1059
5	256QAM	1	0	18.05	18.13	18.16	17.76	0.0597
<b>Limit</b>	<b>EIRP &lt; 23 dBm/10MHz</b>			<b>Result</b>			<b>Pass</b>	

Remark: Total channel power is complied with EIRP limit 23dBm/10MHz.



Summary

Part96 LTE Band 43 MaxiMum Average Power [dBm](GT-LC= -0.4 dB)								
BW (MHz)	Modulation	RB Size	RB Offset	Lowest	Middle	Highest	EIRP (dBm)	EIRP (W)
Channel				43690	44090	44490		
Frequency				3610	3650	3690		
20	QPSK	1	0	22.69	22.68	22.73	22.33	0.1710
20	QPSK	1	99	22.57	22.58	22.72		
20	QPSK	100	0	21.58	21.55	21.75		
20	16QAM	1	0	21.51	21.78	21.71	21.38	0.1374
20	64QAM	1	0	20.56	20.65	20.75	20.35	0.1084
20	256QAM	1	0	17.82	18.02	18.17	17.77	0.0598
Channel				43665	44090	44515	EIRP (dBm)	EIRP (W)
Frequency				3607.5	3650	3692.5		
15	QPSK	1	0	22.53	22.56	22.73	22.33	0.1710
15	QPSK	1	74	22.51	22.5	22.72		
15	QPSK	75	0	21.55	21.59	21.75		
15	16QAM	1	0	21.59	21.61	21.66	21.26	0.1337
15	64QAM	1	0	20.64	20.55	20.76	20.36	0.1086
15	256QAM	1	0	17.93	18.03	18.22	17.82	0.0605
Channel				43640	44090	44540	EIRP (dBm)	EIRP (W)
Frequency				3605	3650	3695		
10	QPSK	1	0	22.64	22.67	22.7	22.3	0.1698
10	QPSK	1	49	22.59	22.65	22.69		
10	QPSK	50	0	21.59	21.66	21.72		
10	16QAM	1	0	21.53	21.62	21.62	21.22	0.1324
10	64QAM	1	0	20.56	20.68	20.73	20.33	0.1079
10	256QAM	1	0	18.03	18.06	18.18	17.78	0.0600
Channel				43615	44090	44545	EIRP (dBm)	EIRP (W)
Frequency				3602.5	3650	3697.5		
5	QPSK	1	0	22.62	22.61	22.69	22.29	0.1694
5	QPSK	1	24	22.55	22.59	22.68		
5	QPSK	25	0	21.58	21.58	21.69		
5	16QAM	1	0	21.49	21.63	21.65	21.25	0.1334
5	64QAM	1	0	20.48	20.65	20.7	20.3	0.1072
5	256QAM	1	0	18.01	18.02	18.13	17.73	0.0593
<b>Limit</b>	<b>EIRP &lt; 23 dBm/10MHz</b>			<b>Result</b>			<b>Pass</b>	

Remark: Total channel power is complied with EIRP limit 23dBm/10MHz.



<b>Mode</b> LTE Band 48, QPSK, CB:20 MHz, 1 RB, Channel: 55340							
<b>Frequency (MHz)</b>	<b>Antenna Polarity</b>	<b>E.I.R.P (dBm)</b>	<b>Limit (dBm)</b>	<b>Margin (dB)</b>	<b>S.A Reading (dBm)</b>	<b>S.G Power Value (dBm)</b>	<b>Correction Factor (dB)</b>
7102.4	H	-50.08	-40	-10.08	-64.29	-53.26	3.18
10653.6	H	-55.12	-40	-15.12	-69.95	-55.62	0.5
14204.8	H	-52.97	-40	-12.97	-66.6	-52.37	-0.6
7102.4	V	-42.35	-40	-2.35	-57.69	-45.53	3.18
10653.6	V	-55.45	-40	-15.45	-69.93	-55.95	0.5
14204.8	V	-52.49	-40	-12.49	-66.66	-51.89	-0.6

<b>Mode</b> LTE Band 48, QPSK, CB:20 MHz, 1 RB, Channel: 55990							
<b>Frequency (MHz)</b>	<b>Antenna Polarity</b>	<b>E.I.R.P (dBm)</b>	<b>Limit (dBm)</b>	<b>Margin (dB)</b>	<b>S.A Reading (dBm)</b>	<b>S.G Power Value (dBm)</b>	<b>Correction Factor (dB)</b>
7232.4	H	-54.15	-40	-14.15	-68.64	-56.95	2.8
10848.6	H	-54.44	-40	-14.44	-69.34	-54.77	0.33
14464.8	H	-53.21	-40	-13.21	-66.02	-52.42	-0.79
7232.4	V	-44.14	-40	-4.14	-59.77	-46.94	2.8
10848.6	V	-54.79	-40	-14.79	-69.33	-55.12	0.33
14464.8	V	-51.83	-40	-11.83	-66.06	-51.04	-0.79

<b>Mode</b> LTE Band 48, QPSK, CB:20 MHz, 1 RB, Channel: 56640							
<b>Frequency (MHz)</b>	<b>Antenna Polarity</b>	<b>E.I.R.P (dBm)</b>	<b>Limit (dBm)</b>	<b>Margin (dB)</b>	<b>S.A Reading (dBm)</b>	<b>S.G Power Value (dBm)</b>	<b>Correction Factor (dB)</b>
7362.4	H	-50.27	-40	-10.27	-65.32	-53.1	2.83
11043.6	H	-55.09	-40	-15.09	-70.05	-55.33	0.24
14724.8	H	-53.84	-40	-13.84	-67.01	-53.55	-0.29
7362.4	V	-41.96	-40	-1.96	-57.65	-44.79	2.83
11043.6	V	-54.97	-40	-14.97	-69.65	-55.21	0.24
14724.8	V	-51.37	-40	-11.37	-66.96	-51.08	-0.29

NOTE: EIRP = S.G power value + correction factor



UL CA

Mode	LTE UL CA Band 48, QPSK, CB:20MHz, 1 RB, Channel:56640 + Band 13, QPSK, CB:5MHz,1 RB, Channel:23230						
Frequency (MHz)	Antenna Polarity	E.I.R.P (dBm)	Limit (dBm)	Margin (dB)	S.A Reading (dBm)	S.G Power Value (dBm)	Correction Factor (dB)
2908	H	-62.19	-40	-22.19	-70.38	-67.97	5.78
4472	H	-59.86	-40	-19.86	-70.62	-65.87	6.01
7380	H	-54.56	-40	-14.56	-69.68	-57.4	2.84
2908	V	-62.2	-40	-22.2	-70.38	-67.98	5.78
4472	V	-59.92	-40	-19.92	-70.47	-65.93	6.01
7380	V	-53.69	-40	-13.69	-69.38	-56.53	2.84

NOTE: EIRP = S.G power value + correction factor



Summary

Mode	Result	F-Start (Hz)	F-Stop (Hz)	RBW (Hz)	VBW (Hz)	Detector	Freq (Hz)	Level (dBm)	Limit (dBm)	Margin (dB)	Remark	Ref.Limit (dB)
Band 48	-	-	-	-	-	-	-	-	-	-	-	-
LTE_20MHz_Nss1,QPSK_1TX	Pass	3.8G	37G	1M	3M	RMS	36.87239G	-43.76	-40.00	-3.76	-	-
LTE_15MHz_Nss1,QPSK_1TX	Pass	3.8G	37G	1M	3M	RMS	36.83608G	-44.20	-40.00	-4.20	-	-
LTE_10MHz_Nss1,QPSK_1TX	Pass	3.8G	37G	1M	3M	RMS	36.78835G	-43.68	-40.00	-3.68	-	-
LTE_5MHz_Nss1,QPSK_1TX	Pass	3.8G	37G	1M	3M	RMS	36.67215G	-44.01	-40.00	-4.01	-	-



Band 48\_LTE\_20MHz\_Nss1,QPSK\_1TX  
3560MHz\_QPSK\_RB 1

CSE-TX-Sum

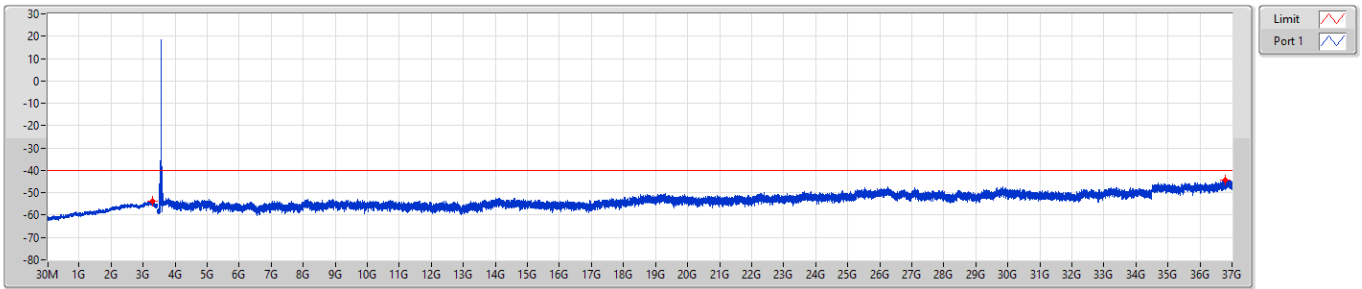

F-Start(Hz)	F-Stop(Hz)	RBW(Hz)	VBW(Hz)	Detector	Freq(Hz)	Level(dBm)	Limit(dBm)	Margin(dB)	Remark	Ref.Limit(dB)
30M	3.45G	1M	3M	RMS	3.28584G	-53.89	-40.00	-13.89	-	-
3.8G	37G	1M	3M	RMS	36.79665G	-44.35	-40.00	-4.35	-	-

Band 48\_LTE\_20MHz\_Nss1,QPSK\_1TX  
3625MHz\_QPSK\_RB 1

CSE-TX-Sum

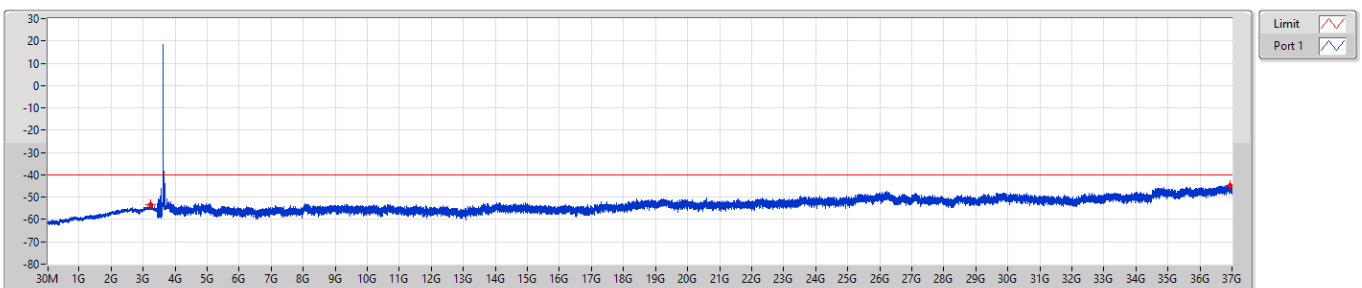

F-Start(Hz)	F-Stop(Hz)	RBW(Hz)	VBW(Hz)	Detector	Freq(Hz)	Level(dBm)	Limit(dBm)	Margin(dB)	Remark	Ref.Limit(dB)
30M	3.45G	1M	3M	RMS	3.24138G	-53.57	-40.00	-13.57	-	-
3.8G	37G	1M	3M	RMS	36.93983G	-44.58	-40.00	-4.58	-	-





Band 48\_LTE\_20MHz\_Nss1,QPSK\_1TX  
3690MHz\_QPSK\_RB 1

CSE-TX-Sum

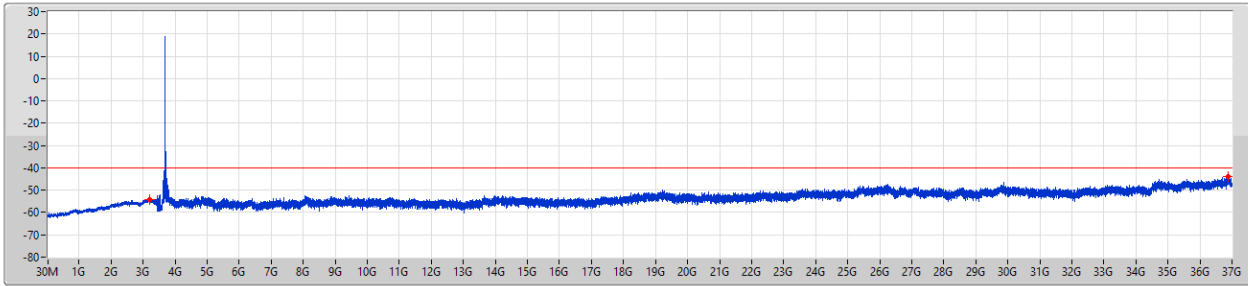

Limit  
Port 1

F-Start(Hz)	F-Stop(Hz)	RBW(Hz)	VBW(Hz)	Detector	Freq(Hz)	Level(dBm)	Limit(dBm)	Margin(dB)	Remark	Ref.Limit(dB)
30M	3.45G	1M	3M	RMS	3.18837G	-54.06	-40.00	-14.06	-	-
3.8G	37G	1M	3M	RMS	36.87239G	-43.76	-40.00	-3.76	-	-

Band 48\_LTE\_15MHz\_Nss1,QPSK\_1TX  
3557.5MHz\_QPSK\_RB 1

CSE-TX-Sum

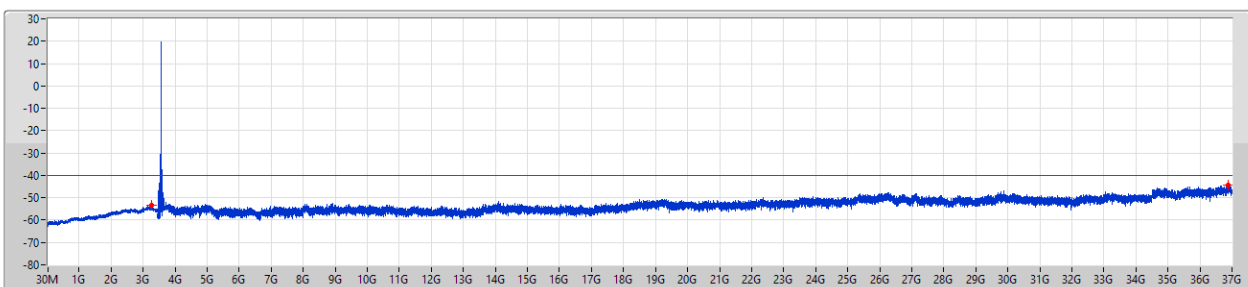

Limit  
Port 1

F-Start(Hz)	F-Stop(Hz)	RBW(Hz)	VBW(Hz)	Detector	Freq(Hz)	Level(dBm)	Limit(dBm)	Margin(dB)	Remark	Ref.Limit(dB)
30M	3.45G	1M	3M	RMS	3.24993G	-53.57	-40.00	-13.57	-	-
3.8G	37G	1M	3M	RMS	36.87654G	-44.31	-40.00	-4.31	-	-



Band 48\_LTE\_15MHz\_Nss1,QPSK\_1TX  
3625MHz\_QPSK\_RB 1

CSE-TX-Sum

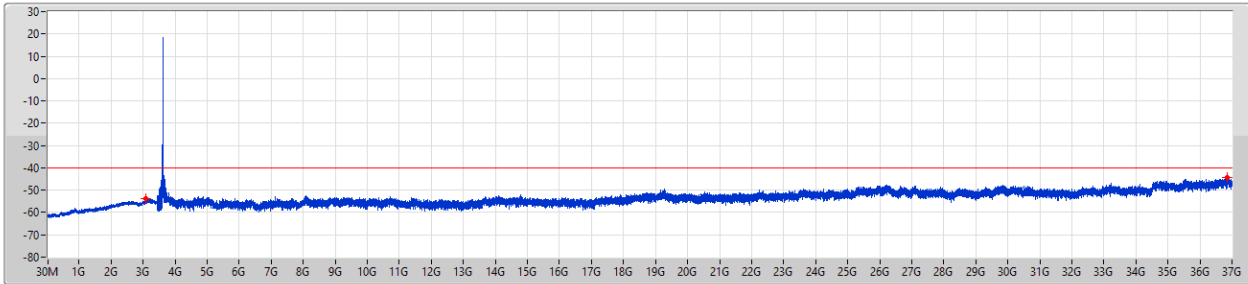

Limit  
Port 1

F-Start(Hz)	F-Stop(Hz)	RBW(Hz)	VBW(Hz)	Detector	Freq(Hz)	Level(dBm)	Limit(dBm)	Margin(dB)	Remark	Ref.Limit(dB)
30M	3.45G	1M	3M	RMS	3.08577G	-53.83	-40.00	-13.83	-	-
3.8G	37G	1M	3M	RMS	36.83608G	-44.20	-40.00	-4.20	-	-

Band 48\_LTE\_15MHz\_Nss1,QPSK\_1TX  
3692.5MHz\_QPSK\_RB 1

CSE-TX-Sum

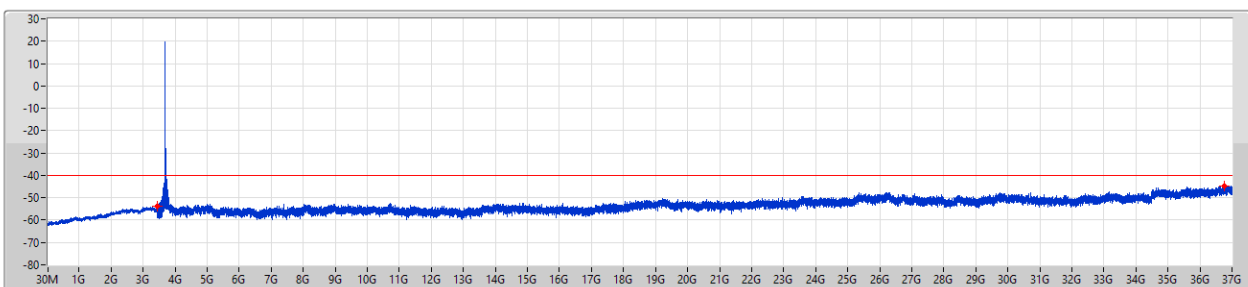

Limit  
Port 1

F-Start(Hz)	F-Stop(Hz)	RBW(Hz)	VBW(Hz)	Detector	Freq(Hz)	Level(dBm)	Limit(dBm)	Margin(dB)	Remark	Ref.Limit(dB)
30M	3.45G	1M	3M	RMS	3.44145G	-53.94	-40.00	-13.94	-	-
3.8G	37G	1M	3M	RMS	36.75826G	-44.81	-40.00	-4.81	-	-



Band 48\_LTE\_10MHz\_Nss1,QPSK\_1TX  
3555MHz\_QPSK\_RB 1

CSE-TX-Sum

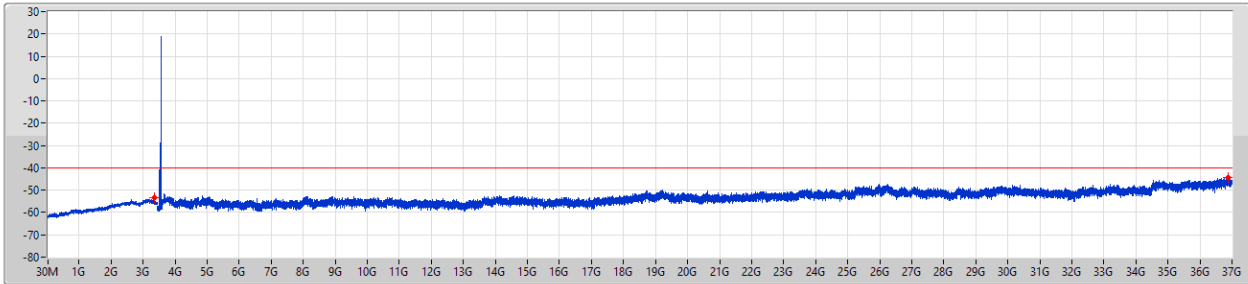

F-Start(Hz)	F-Stop(Hz)	RBW(Hz)	VBW(Hz)	Detector	Freq(Hz)	Level(dBm)	Limit(dBm)	Margin(dB)	Remark	Ref.Limit(dB)
30M	3.45G	1M	3M	RMS	3.35082G	-53.55	-40.00	-13.55	-	-
3.8G	37G	1M	3M	RMS	36.88891G	-44.17	-40.00	-4.17	-	-

Band 48\_LTE\_10MHz\_Nss1,QPSK\_1TX  
3625MHz\_QPSK\_RB 1

CSE-TX-Sum

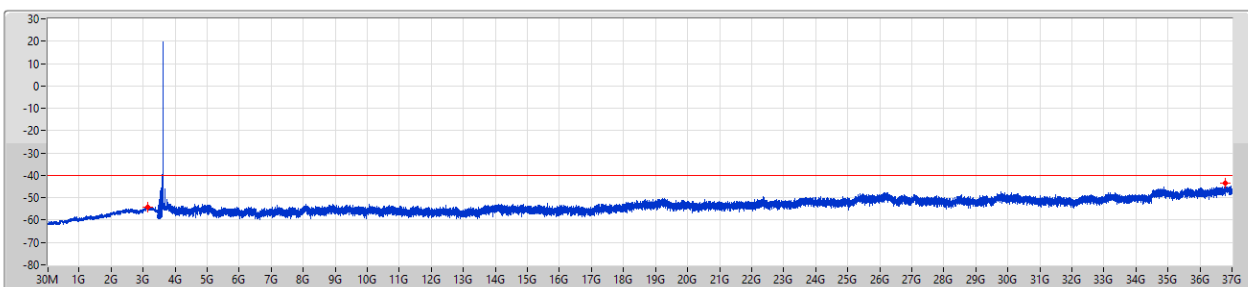

F-Start(Hz)	F-Stop(Hz)	RBW(Hz)	VBW(Hz)	Detector	Freq(Hz)	Level(dBm)	Limit(dBm)	Margin(dB)	Remark	Ref.Limit(dB)
30M	3.45G	1M	3M	RMS	3.15246G	-54.04	-40.00	-14.04	-	-
3.8G	37G	1M	3M	RMS	36.78835G	-43.68	-40.00	-3.68	-	-



Band 48\_LTE\_10MHz\_Nss1,QPSK\_1TX

CSE-TX-Sum

3695MHz\_QPSK\_RB 1

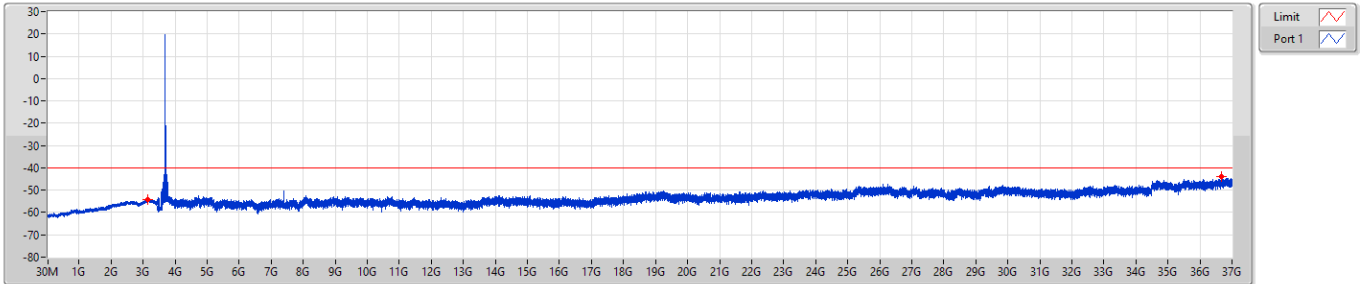

F-Start(Hz)	F-Stop(Hz)	RBW(Hz)	VBW(Hz)	Detector	Freq(Hz)	Level(dBm)	Limit(dBm)	Margin(dB)	Remark	Ref.Limit(dB)
30M	3.45G	1M	3M	RMS	3.13023G	-54.21	-40.00	-14.21	-	-
3.8G	37G	1M	3M	RMS	36.68564G	-43.95	-40.00	-3.95	-	-

Band 48\_LTE\_5MHz\_Nss1,QPSK\_1TX

CSE-TX-Sum

3552.5MHz\_QPSK\_RB 1

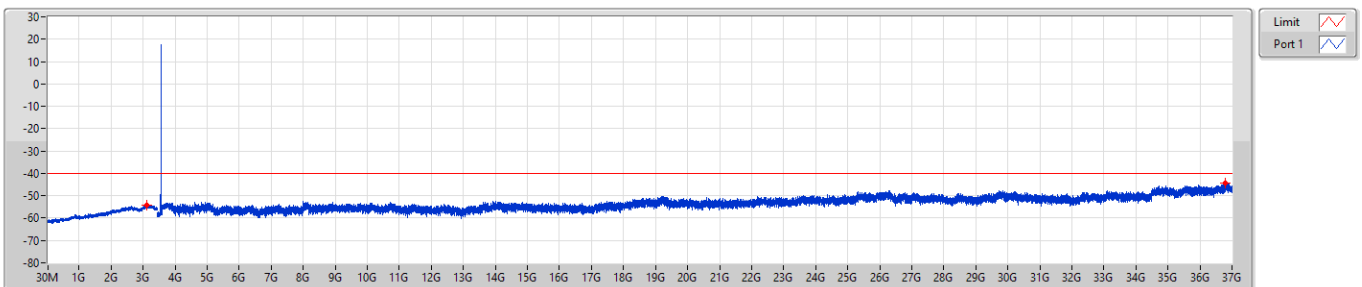

F-Start(Hz)	F-Stop(Hz)	RBW(Hz)	VBW(Hz)	Detector	Freq(Hz)	Level(dBm)	Limit(dBm)	Margin(dB)	Remark	Ref.Limit(dB)
30M	3.45G	1M	3M	RMS	3.11997G	-54.17	-40.00	-14.17	-	-
3.8G	37G	1M	3M	RMS	36.7842G	-44.17	-40.00	-4.17	-	-



Band 48\_LTE\_5MHz\_Nss1,QPSK\_1TX  
3625MHz\_QPSK\_RB 1

CSE-TX-Sum

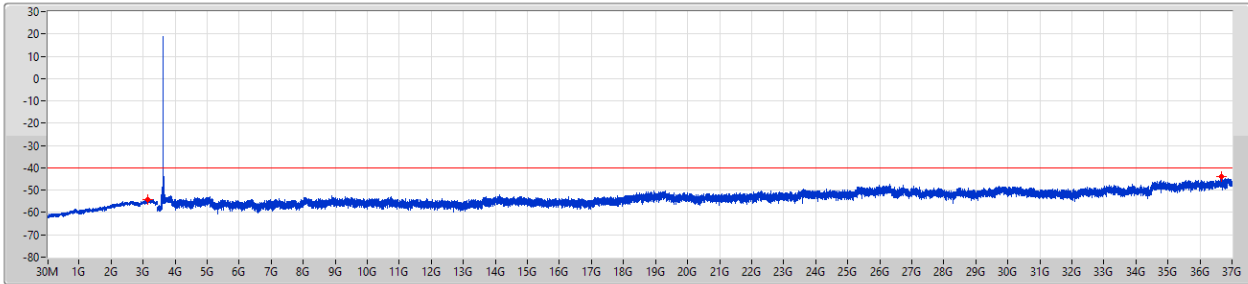

Limit   
Port 1

F-Start(Hz)	F-Stop(Hz)	RBW(Hz)	VBW(Hz)	Detector	Freq(Hz)	Level(dBm)	Limit(dBm)	Margin(dB)	Remark	Ref.Limit(dB)
30M	3.45G	1M	3M	RMS	3.14391G	-54.22	-40.00	-14.22	-	-
3.8G	37G	1M	3M	RMS	36.67215G	-44.01	-40.00	-4.01	-	-

Band 48\_LTE\_5MHz\_Nss1,QPSK\_1TX  
3697.5MHz\_QPSK\_RB 1

CSE-TX-Sum

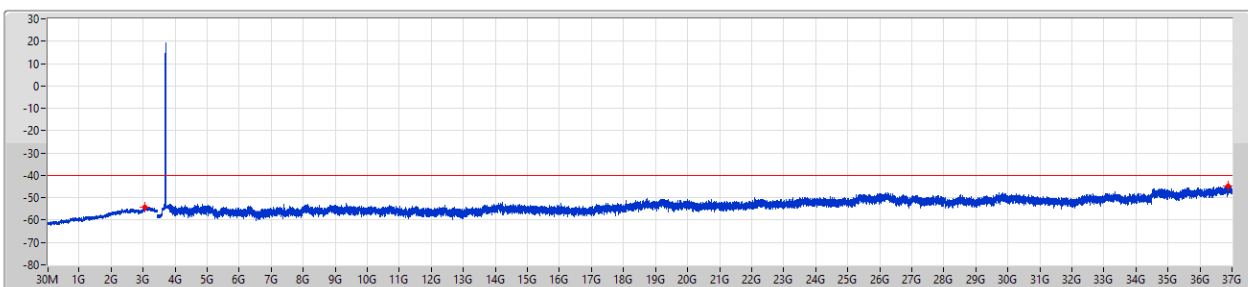

Limit   
Port 1

F-Start(Hz)	F-Stop(Hz)	RBW(Hz)	VBW(Hz)	Detector	Freq(Hz)	Level(dBm)	Limit(dBm)	Margin(dB)	Remark	Ref.Limit(dB)
30M	3.45G	1M	3M	RMS	3.04473G	-54.32	-40.00	-14.32	-	-
3.8G	37G	1M	3M	RMS	36.88069G	-44.62	-40.00	-4.62	-	-



**Summary**

Mode	Result	F-Start (Hz)	F-Stop (Hz)	RBW (Hz)	VBW (Hz)	Detector	Freq (Hz)	Level (dBm)	Limit (dBm)	Margin (dB)	Remark	Ref.Limit (dB)
Band 48	-	-	-	-	-	-	-	-	-	-	-	-
LTE_20MHz_Nss1,QPSK_1TX	Pass	3.45G	3.53G	200k	1M	RMS	3.5295G	-43.21	-40.00	-3.21	MBW 1M	-
LTE_20MHz_Nss1,16QAM_1TX	Pass	3.45G	3.53G	200k	1M	RMS	3.5295G	-45.71	-40.00	-5.71	MBW 1M	-
LTE_20MHz_Nss1,64QAM_1TX	Pass	3.72G	3.8G	200k	1M	RMS	3.7205G	-47.83	-40.00	-7.83	MBW 1M	-
LTE_20MHz_Nss1,256QAM_1TX	Pass	3.72G	3.8G	200k	1M	RMS	3.7215G	-50.98	-40.00	-10.98	MBW 1M	-
LTE_15MHz_Nss1,QPSK_1TX	Pass	3.45G	3.53G	200k	1M	RMS	3.5295G	-46.23	-40.00	-6.23	MBW 1M	-
LTE_15MHz_Nss1,16QAM_1TX	Pass	3.6165G	3.6175G	200k	1M	RMS	3.61748G	-21.22	-13.00	-8.22	-	-
LTE_15MHz_Nss1,64QAM_1TX	Pass	3.6165G	3.6175G	200k	1M	RMS	3.61742G	-21.70	-13.00	-8.70	-	-
LTE_15MHz_Nss1,256QAM_1TX	Pass	3.45G	3.53G	200k	1M	RMS	3.5265G	-49.84	-40.00	-9.84	MBW 1M	-
LTE_10MHz_Nss1,QPSK_1TX	Pass	3.7G	3.701G	100k	300k	RMS	3.7G	-20.74	-13.00	-7.74	-	-
LTE_10MHz_Nss1,16QAM_1TX	Pass	3.72G	3.8G	100k	300k	RMS	3.7265G	-48.52	-40.00	-8.52	MBW 1M	-
LTE_10MHz_Nss1,64QAM_1TX	Pass	3.45G	3.53G	100k	300k	RMS	3.5285G	-48.65	-40.00	-8.65	MBW 1M	-
LTE_10MHz_Nss1,256QAM_1TX	Pass	3.72G	3.8G	100k	300k	RMS	3.7345G	-50.04	-40.00	-10.04	MBW 1M	-
LTE_5MHz_Nss1,QPSK_1TX	Pass	3.549G	3.55G	50k	200k	RMS	3.54999G	-17.95	-13.00	-4.95	-	-
LTE_5MHz_Nss1,16QAM_1TX	Pass	3.7G	3.701G	50k	200k	RMS	3.7G	-18.83	-13.00	-5.83	-	-
LTE_5MHz_Nss1,64QAM_1TX	Pass	3.7G	3.701G	50k	200k	RMS	3.70001G	-20.43	-13.00	-7.43	-	-
LTE_5MHz_Nss1,256QAM_1TX	Pass	3.6215G	3.6225G	50k	200k	RMS	3.6225G	-22.46	-13.00	-9.46	-	-



Band 48\_LTE\_20MHz\_Nss1,QPSK\_1TX  
3560MHz\_QPSK\_RB 100,#RB 0

CSE-TX-Sum

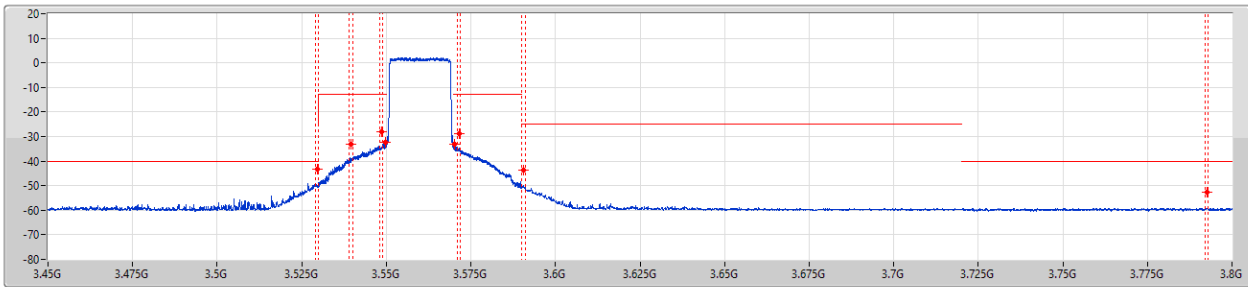

F-Start(Hz)	F-Stop(Hz)	RBW(Hz)	VBW(Hz)	Detector	Freq(Hz)	Level(dBm)	Limit(dBm)	Margin(dB)	Remark	Ref.Limit(dB)
3.45G	3.53G	200k	1M	RMS	3.5295G	-43.21	-40.00	-3.21	MBW 1M	-
3.53G	3.54G	200k	1M	RMS	3.5395G	-33.12	-13.00	-20.12	MBW 1M	-
3.54G	3.549G	200k	1M	RMS	3.5485G	-27.99	-13.00	-14.99	MBW 1M	-
3.549G	3.55G	200k	1M	RMS	3.54988G	-32.28	-13.00	-19.28	-	-
3.57G	3.571G	200k	1M	RMS	3.57003G	-33.02	-13.00	-20.02	-	-
3.571G	3.59G	200k	1M	RMS	3.5715G	-28.84	-13.00	-15.84	MBW 1M	-
3.59G	3.72G	200k	1M	RMS	3.5905G	-43.77	-25.00	-18.77	MBW 1M	-
3.72G	3.8G	200k	1M	RMS	3.7925G	-52.78	-40.00	-12.78	MBW 1M	-

Band 48\_LTE\_20MHz\_Nss1,QPSK\_1TX  
3560MHz\_QPSK\_RB 1,#RB L

CSE-TX-Sum

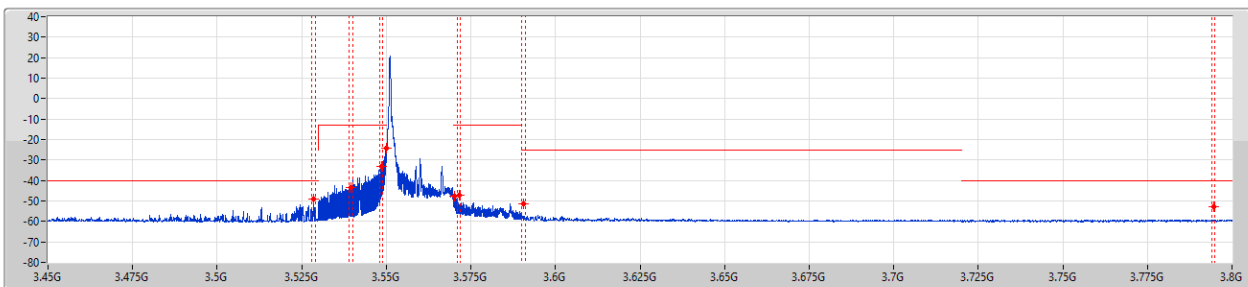

F-Start(Hz)	F-Stop(Hz)	RBW(Hz)	VBW(Hz)	Detector	Freq(Hz)	Level(dBm)	Limit(dBm)	Margin(dB)	Remark	Ref.Limit(dB)
3.45G	3.53G	200k	1M	RMS	3.5285G	-49.08	-40.00	-9.08	MBW 1M	-
3.53G	3.54G	200k	1M	RMS	3.5395G	-43.66	-13.00	-30.66	MBW 1M	-
3.54G	3.549G	200k	1M	RMS	3.5485G	-33.07	-13.00	-20.07	MBW 1M	-
3.549G	3.55G	200k	1M	RMS	3.54999G	-24.23	-13.00	-11.23	-	-
3.57G	3.571G	200k	1M	RMS	3.57027G	-47.51	-13.00	-34.51	-	-
3.571G	3.59G	200k	1M	RMS	3.5715G	-46.97	-13.00	-33.97	MBW 1M	-
3.59G	3.72G	200k	1M	RMS	3.5905G	-51.57	-25.00	-26.57	MBW 1M	-
3.72G	3.8G	200k	1M	RMS	3.7945G	-52.83	-40.00	-12.83	MBW 1M	-



Band 48\_LTE\_20MHz\_Nss1,QPSK\_1TX  
3625MHz\_QPSK\_RB 100,#RB 0

CSE-TX-Sum

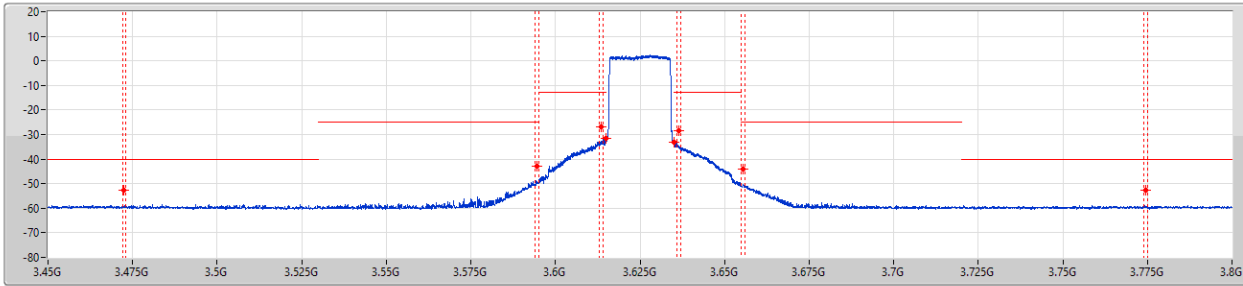

F-Start(Hz)	F-Stop(Hz)	RBW(Hz)	VBW(Hz)	Detector	Freq(Hz)	Level(dBm)	Limit(dBm)	Margin(dB)	Remark	Ref.Limit(dB)
3.45G	3.53G	200k	1M	RMS	3.4725G	-52.67	-40.00	-12.67	MBW 1M	-
3.53G	3.595G	200k	1M	RMS	3.5945G	-43.03	-25.00	-18.03	MBW 1M	-
3.595G	3.614G	200k	1M	RMS	3.6135G	-26.96	-13.00	-13.96	MBW 1M	-
3.614G	3.615G	200k	1M	RMS	3.61492G	-31.42	-13.00	-18.42	-	-
3.635G	3.636G	200k	1M	RMS	3.63514G	-33.15	-13.00	-20.15	-	-
3.636G	3.655G	200k	1M	RMS	3.6365G	-28.31	-13.00	-15.31	MBW 1M	-
3.655G	3.72G	200k	1M	RMS	3.6555G	-44.23	-25.00	-19.23	MBW 1M	-
3.72G	3.8G	200k	1M	RMS	3.7745G	-52.74	-40.00	-12.74	MBW 1M	-

Band 48\_LTE\_20MHz\_Nss1,QPSK\_1TX  
3625MHz\_QPSK\_RB 1,#RB L

CSE-TX-Sum

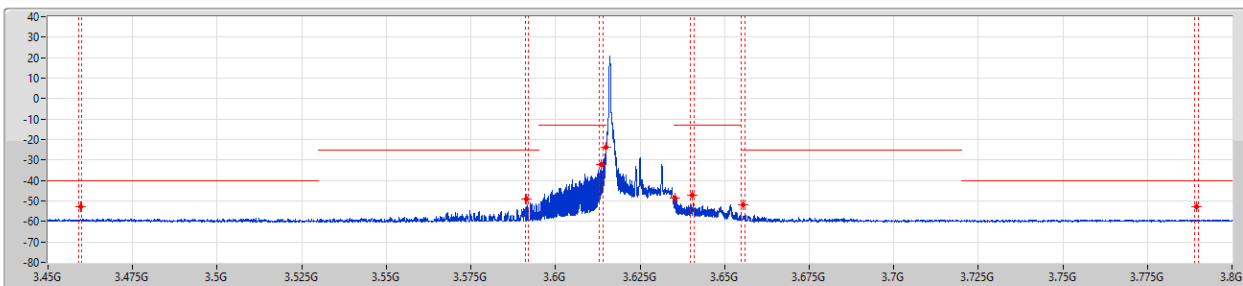

F-Start(Hz)	F-Stop(Hz)	RBW(Hz)	VBW(Hz)	Detector	Freq(Hz)	Level(dBm)	Limit(dBm)	Margin(dB)	Remark	Ref.Limit(dB)
3.45G	3.53G	200k	1M	RMS	3.4595G	-52.68	-40.00	-12.68	MBW 1M	-
3.53G	3.595G	200k	1M	RMS	3.5915G	-49.11	-25.00	-24.11	MBW 1M	-
3.595G	3.614G	200k	1M	RMS	3.6135G	-32.34	-13.00	-19.34	MBW 1M	-
3.614G	3.615G	200k	1M	RMS	3.61497G	-23.87	-13.00	-10.87	-	-
3.635G	3.636G	200k	1M	RMS	3.63528G	-48.48	-13.00	-35.48	-	-
3.636G	3.655G	200k	1M	RMS	3.6405G	-47.34	-13.00	-34.34	MBW 1M	-
3.655G	3.72G	200k	1M	RMS	3.6555G	-51.81	-25.00	-26.81	MBW 1M	-
3.72G	3.8G	200k	1M	RMS	3.7895G	-52.84	-40.00	-12.84	MBW 1M	-





Band 48\_LTE\_20MHz\_Nss1,QPSK\_1TX  
3690MHz\_QPSK\_RB 100,#RB 0

CSE-TX-Sum

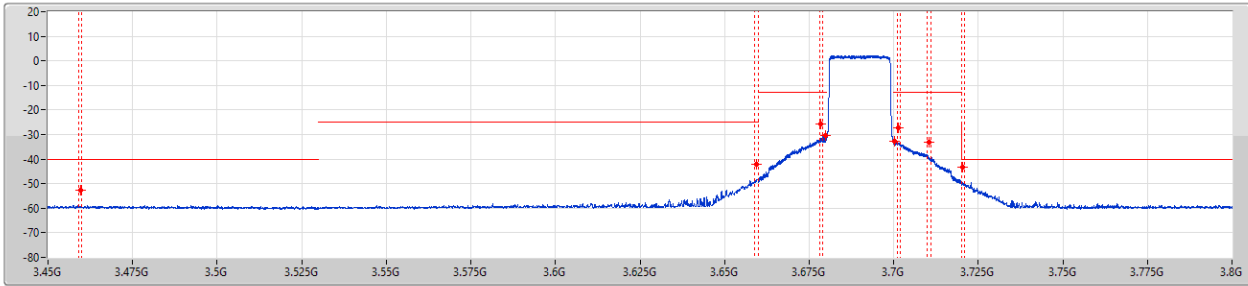

Limit   
Port 1

F-Start(Hz)	F-Stop(Hz)	RBW(Hz)	VBW(Hz)	Detector	Freq(Hz)	Level(dBm)	Limit(dBm)	Margin(dB)	Remark	Ref.Limit(dB)
3.45G	3.53G	200k	1M	RMS	3.4595G	-52.71	-40.00	-12.71	MBW 1M	-
3.53G	3.66G	200k	1M	RMS	3.6595G	-42.02	-25.00	-17.02	MBW 1M	-
3.66G	3.679G	200k	1M	RMS	3.6785G	-25.66	-13.00	-12.66	MBW 1M	-
3.679G	3.68G	200k	1M	RMS	3.67987G	-30.44	-13.00	-17.44	-	-
3.7G	3.701G	200k	1M	RMS	3.7003G	-32.58	-13.00	-19.58	-	-
3.701G	3.71G	200k	1M	RMS	3.7015G	-27.13	-13.00	-14.13	MBW 1M	-
3.71G	3.72G	200k	1M	RMS	3.7105G	-33.00	-13.00	-20.00	MBW 1M	-
3.72G	3.8G	200k	1M	RMS	3.7205G	-43.39	-40.00	-3.39	MBW 1M	-

Band 48\_LTE\_20MHz\_Nss1,QPSK\_1TX  
3690MHz\_QPSK\_RB 1,#RB R

CSE-TX-Sum

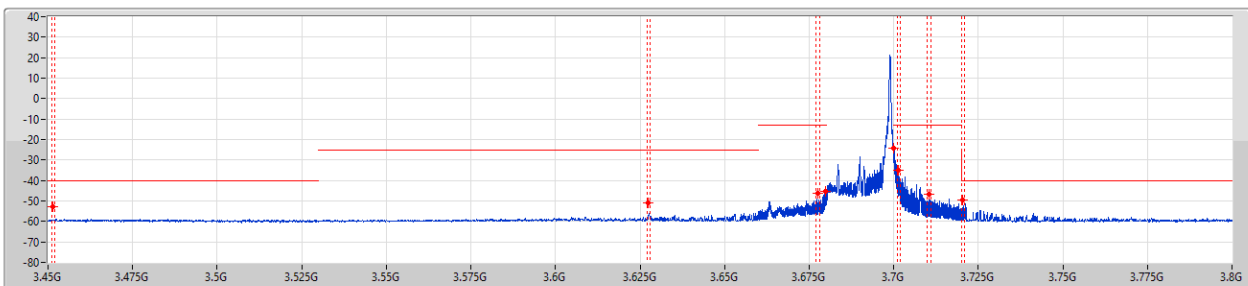

Limit   
Port 1

F-Start(Hz)	F-Stop(Hz)	RBW(Hz)	VBW(Hz)	Detector	Freq(Hz)	Level(dBm)	Limit(dBm)	Margin(dB)	Remark	Ref.Limit(dB)
3.45G	3.53G	200k	1M	RMS	3.4515G	-52.70	-40.00	-12.70	MBW 1M	-
3.53G	3.66G	200k	1M	RMS	3.6275G	-50.87	-25.00	-25.87	MBW 1M	-
3.66G	3.679G	200k	1M	RMS	3.6775G	-46.26	-13.00	-33.26	MBW 1M	-
3.679G	3.68G	200k	1M	RMS	3.67971G	-45.08	-13.00	-32.08	-	-
3.7G	3.701G	200k	1M	RMS	3.70003G	-23.99	-13.00	-10.99	-	-
3.701G	3.71G	200k	1M	RMS	3.7015G	-34.77	-13.00	-21.77	MBW 1M	-
3.71G	3.72G	200k	1M	RMS	3.7105G	-46.80	-13.00	-33.80	MBW 1M	-
3.72G	3.8G	200k	1M	RMS	3.7205G	-49.65	-40.00	-9.65	MBW 1M	-



Band 48\_LTE\_20MHz\_Nss1,16QAM\_1TX  
3560MHz\_16QAM\_RB 100,#RB 0

CSE-TX-Sum

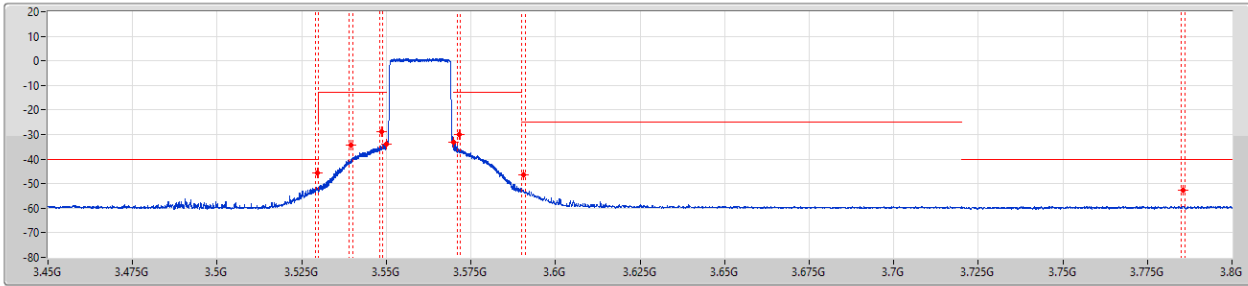

F-Start(Hz)	F-Stop(Hz)	RBW(Hz)	VBW(Hz)	Detector	Freq(Hz)	Level(dBm)	Limit(dBm)	Margin(dB)	Remark	Ref.Limit(dB)
3.45G	3.53G	200k	1M	RMS	3.5295G	-45.71	-40.00	-5.71	MBW 1M	-
3.53G	3.54G	200k	1M	RMS	3.5395G	-34.28	-13.00	-21.28	MBW 1M	-
3.54G	3.549G	200k	1M	RMS	3.5485G	-28.98	-13.00	-15.98	MBW 1M	-
3.549G	3.55G	200k	1M	RMS	3.54997G	-33.88	-13.00	-20.88	-	-
3.57G	3.571G	200k	1M	RMS	3.57002G	-33.06	-13.00	-20.06	-	-
3.571G	3.59G	200k	1M	RMS	3.5715G	-29.96	-13.00	-16.96	MBW 1M	-
3.59G	3.72G	200k	1M	RMS	3.5905G	-46.28	-25.00	-21.28	MBW 1M	-
3.72G	3.8G	200k	1M	RMS	3.7855G	-52.85	-40.00	-12.85	MBW 1M	-

Band 48\_LTE\_20MHz\_Nss1,16QAM\_1TX  
3560MHz\_16QAM\_RB 1,#RB L

CSE-TX-Sum

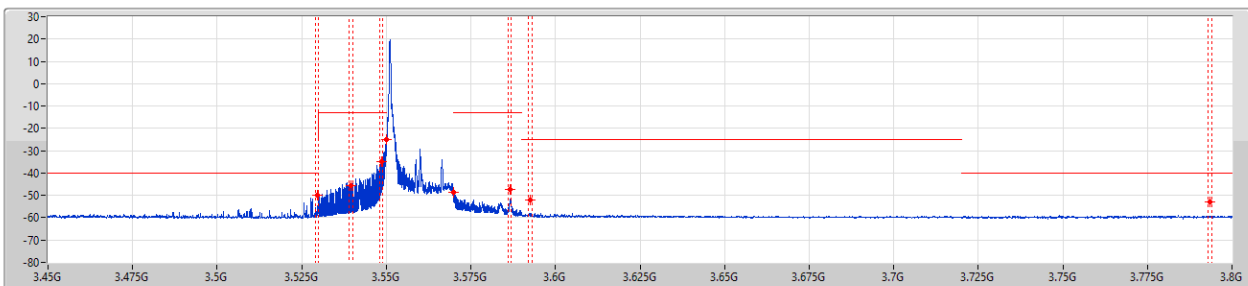

F-Start(Hz)	F-Stop(Hz)	RBW(Hz)	VBW(Hz)	Detector	Freq(Hz)	Level(dBm)	Limit(dBm)	Margin(dB)	Remark	Ref.Limit(dB)
3.45G	3.53G	200k	1M	RMS	3.5295G	-49.96	-40.00	-9.96	MBW 1M	-
3.53G	3.54G	200k	1M	RMS	3.5395G	-45.53	-13.00	-32.53	MBW 1M	-
3.54G	3.549G	200k	1M	RMS	3.5485G	-35.02	-13.00	-22.02	MBW 1M	-
3.549G	3.55G	200k	1M	RMS	3.54998G	-25.13	-13.00	-12.13	-	-
3.57G	3.571G	200k	1M	RMS	3.57002G	-48.84	-13.00	-35.84	-	-
3.571G	3.59G	200k	1M	RMS	3.5865G	-47.19	-13.00	-34.19	MBW 1M	-
3.59G	3.72G	200k	1M	RMS	3.5925G	-51.86	-25.00	-26.86	MBW 1M	-
3.72G	3.8G	200k	1M	RMS	3.7935G	-52.90	-40.00	-12.90	MBW 1M	-



Band 48\_LTE\_20MHz\_Nss1,16QAM\_1TX  
3625MHz\_16QAM\_RB 100,#RB 0

CSE-TX-Sum

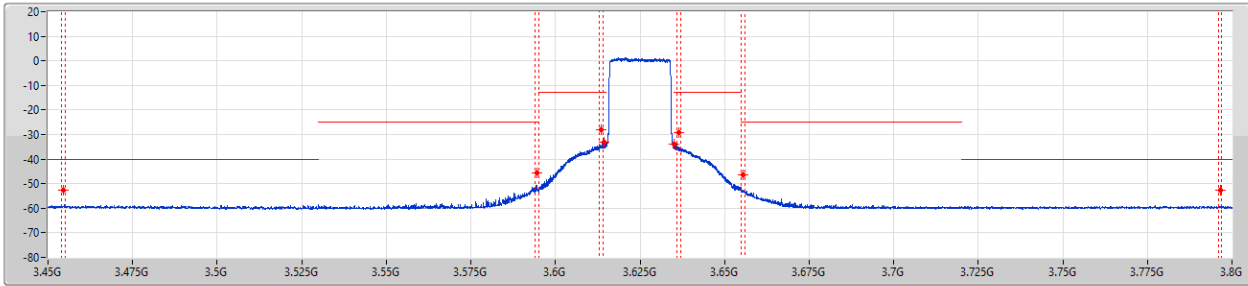

F-Start(Hz)	F-Stop(Hz)	RBW(Hz)	VBW(Hz)	Detector	Freq(Hz)	Level(dBm)	Limit(dBm)	Margin(dB)	Remark	Ref.Limit(dB)
3.45G	3.53G	200k	1M	RMS	3.4545G	-52.61	-40.00	-12.61	MBW 1M	-
3.53G	3.595G	200k	1M	RMS	3.5945G	-45.67	-25.00	-20.67	MBW 1M	-
3.595G	3.614G	200k	1M	RMS	3.6135G	-28.21	-13.00	-15.21	MBW 1M	-
3.614G	3.615G	200k	1M	RMS	3.61448G	-33.23	-13.00	-20.23	-	-
3.635G	3.636G	200k	1M	RMS	3.63518G	-33.90	-13.00	-20.90	-	-
3.636G	3.655G	200k	1M	RMS	3.6365G	-29.13	-13.00	-16.13	MBW 1M	-
3.655G	3.72G	200k	1M	RMS	3.6555G	-46.46	-25.00	-21.46	MBW 1M	-
3.72G	3.8G	200k	1M	RMS	3.7965G	-52.78	-40.00	-12.78	MBW 1M	-

Band 48\_LTE\_20MHz\_Nss1,16QAM\_1TX  
3625MHz\_16QAM\_RB 1,#RB L

CSE-TX-Sum

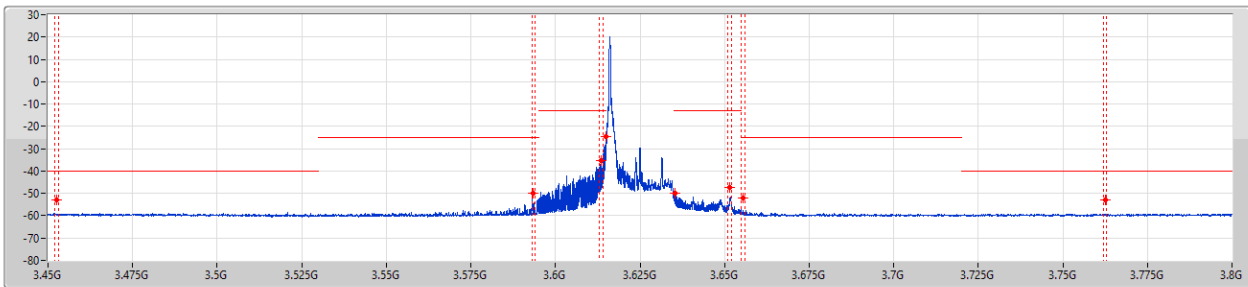

F-Start(Hz)	F-Stop(Hz)	RBW(Hz)	VBW(Hz)	Detector	Freq(Hz)	Level(dBm)	Limit(dBm)	Margin(dB)	Remark	Ref.Limit(dB)
3.45G	3.53G	200k	1M	RMS	3.4525G	-52.73	-40.00	-12.73	MBW 1M	-
3.53G	3.595G	200k	1M	RMS	3.5935G	-49.73	-25.00	-24.73	MBW 1M	-
3.595G	3.614G	200k	1M	RMS	3.6135G	-35.49	-13.00	-22.49	MBW 1M	-
3.614G	3.615G	200k	1M	RMS	3.615G	-24.37	-13.00	-11.37	-	-
3.635G	3.636G	200k	1M	RMS	3.63529G	-49.73	-13.00	-36.73	-	-
3.636G	3.655G	200k	1M	RMS	3.6515G	-47.28	-13.00	-34.28	MBW 1M	-
3.655G	3.72G	200k	1M	RMS	3.6555G	-52.19	-25.00	-27.19	MBW 1M	-
3.72G	3.8G	200k	1M	RMS	3.7625G	-52.83	-40.00	-12.83	MBW 1M	-



Band 48\_LTE\_20MHz\_Nss1,16QAM\_1TX  
3690MHz\_16QAM\_RB 100,#RB 0

CSE-TX-Sum

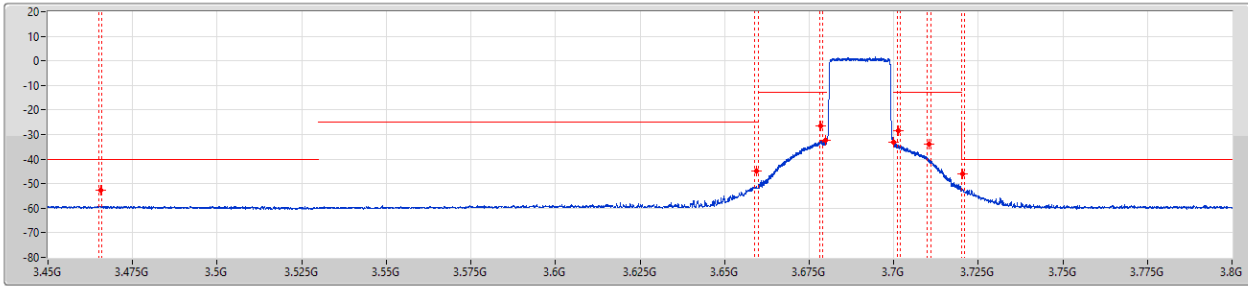

F-Start(Hz)	F-Stop(Hz)	RBW(Hz)	VBW(Hz)	Detector	Freq(Hz)	Level(dBm)	Limit(dBm)	Margin(dB)	Remark	Ref.Limit(dB)
3.45G	3.53G	200k	1M	RMS	3.4655G	-52.77	-40.00	-12.77	MBW 1M	-
3.53G	3.66G	200k	1M	RMS	3.6595G	-44.89	-25.00	-19.89	MBW 1M	-
3.66G	3.679G	200k	1M	RMS	3.6785G	-26.64	-13.00	-13.64	MBW 1M	-
3.679G	3.68G	200k	1M	RMS	3.67983G	-32.25	-13.00	-19.25	-	-
3.7G	3.701G	200k	1M	RMS	3.7G	-33.30	-13.00	-20.30	-	-
3.701G	3.71G	200k	1M	RMS	3.7015G	-28.28	-13.00	-15.28	MBW 1M	-
3.71G	3.72G	200k	1M	RMS	3.7105G	-33.98	-13.00	-20.98	MBW 1M	-
3.72G	3.8G	200k	1M	RMS	3.7205G	-46.10	-40.00	-6.10	MBW 1M	-

Band 48\_LTE\_20MHz\_Nss1,16QAM\_1TX  
3690MHz\_16QAM\_RB 1,#RB R

CSE-TX-Sum

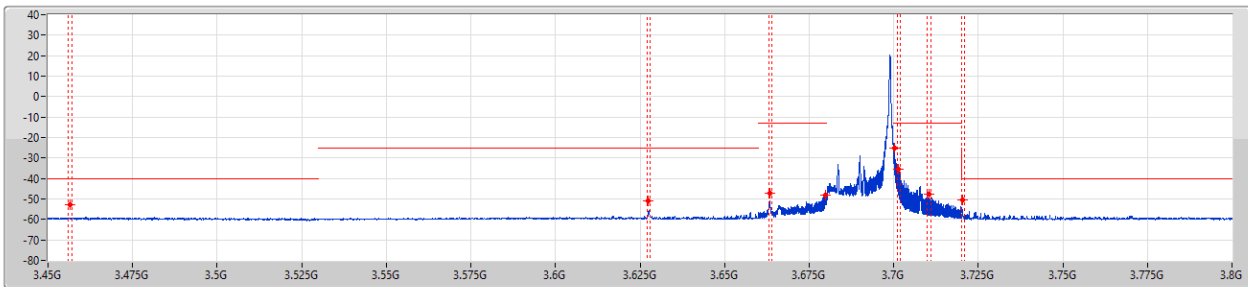

F-Start(Hz)	F-Stop(Hz)	RBW(Hz)	VBW(Hz)	Detector	Freq(Hz)	Level(dBm)	Limit(dBm)	Margin(dB)	Remark	Ref.Limit(dB)
3.45G	3.53G	200k	1M	RMS	3.4565G	-52.75	-40.00	-12.75	MBW 1M	-
3.53G	3.66G	200k	1M	RMS	3.6275G	-50.72	-25.00	-25.72	MBW 1M	-
3.66G	3.679G	200k	1M	RMS	3.6635G	-47.05	-13.00	-34.05	MBW 1M	-
3.679G	3.68G	200k	1M	RMS	3.67995G	-48.25	-13.00	-35.25	-	-
3.7G	3.701G	200k	1M	RMS	3.70011G	-25.28	-13.00	-12.28	-	-
3.701G	3.71G	200k	1M	RMS	3.7015G	-35.29	-13.00	-22.29	MBW 1M	-
3.71G	3.72G	200k	1M	RMS	3.7105G	-47.62	-13.00	-34.62	MBW 1M	-
3.72G	3.8G	200k	1M	RMS	3.7205G	-50.56	-40.00	-10.56	MBW 1M	-



Band 48\_LTE\_20MHz\_Nss1,64QAM\_1TX  
3560MHz\_64QAM\_RB 100,#RB 0

CSE-TX-Sum

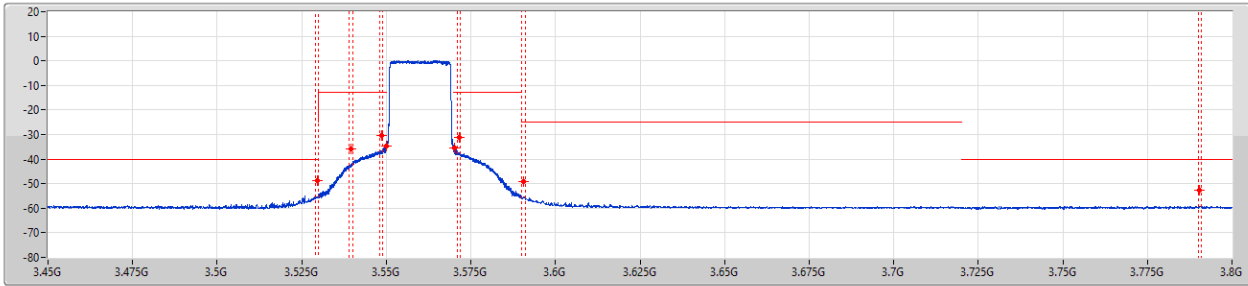

Limit

Port 1

F-Start(Hz)	F-Stop(Hz)	RBW(Hz)	VBW(Hz)	Detector	Freq(Hz)	Level(dBm)	Limit(dBm)	Margin(dB)	Remark	Ref.Limit(dB)
3.45G	3.53G	200k	1M	RMS	3.5295G	-48.75	-40.00	-8.75	MBW 1M	-
3.53G	3.54G	200k	1M	RMS	3.5395G	-35.86	-13.00	-22.86	MBW 1M	-
3.54G	3.549G	200k	1M	RMS	3.5485G	-30.38	-13.00	-17.38	MBW 1M	-
3.549G	3.55G	200k	1M	RMS	3.54999G	-34.84	-13.00	-21.84	-	-
3.57G	3.571G	200k	1M	RMS	3.57008G	-35.53	-13.00	-22.53	-	-
3.571G	3.59G	200k	1M	RMS	3.5715G	-31.18	-13.00	-18.18	MBW 1M	-
3.59G	3.72G	200k	1M	RMS	3.5905G	-49.01	-25.00	-24.01	MBW 1M	-
3.72G	3.8G	200k	1M	RMS	3.7905G	-52.77	-40.00	-12.77	MBW 1M	-

Band 48\_LTE\_20MHz\_Nss1,64QAM\_1TX  
3560MHz\_64QAM\_RB 1,#RB L

CSE-TX-Sum

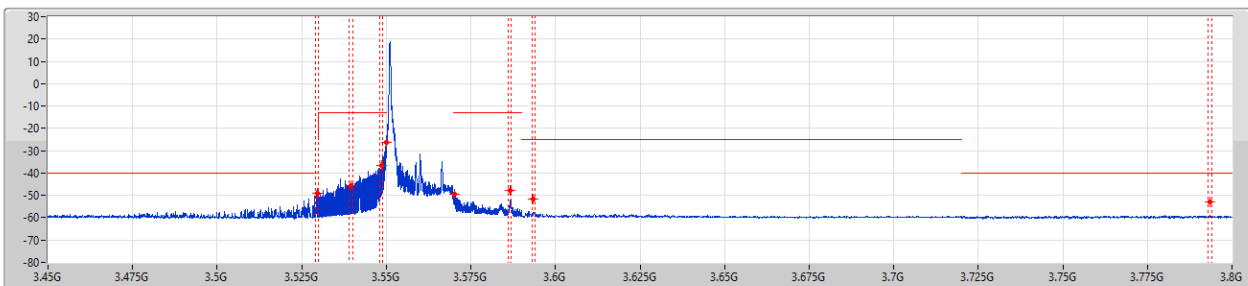

Limit

Port 1

F-Start(Hz)	F-Stop(Hz)	RBW(Hz)	VBW(Hz)	Detector	Freq(Hz)	Level(dBm)	Limit(dBm)	Margin(dB)	Remark	Ref.Limit(dB)
3.45G	3.53G	200k	1M	RMS	3.5295G	-49.20	-40.00	-9.20	MBW 1M	-
3.53G	3.54G	200k	1M	RMS	3.5395G	-45.54	-13.00	-32.54	MBW 1M	-
3.54G	3.549G	200k	1M	RMS	3.5485G	-36.69	-13.00	-23.69	MBW 1M	-
3.549G	3.55G	200k	1M	RMS	3.54999G	-26.41	-13.00	-13.41	-	-
3.57G	3.571G	200k	1M	RMS	3.57028G	-49.57	-13.00	-36.57	-	-
3.571G	3.59G	200k	1M	RMS	3.5865G	-47.90	-13.00	-34.90	MBW 1M	-
3.59G	3.72G	200k	1M	RMS	3.5935G	-51.54	-25.00	-26.54	MBW 1M	-
3.72G	3.8G	200k	1M	RMS	3.7935G	-52.83	-40.00	-12.83	MBW 1M	-



Band 48\_LTE\_20MHz\_Nss1,64QAM\_1TX  
3625MHz\_64QAM\_RB 100,#RB 0

CSE-TX-Sum

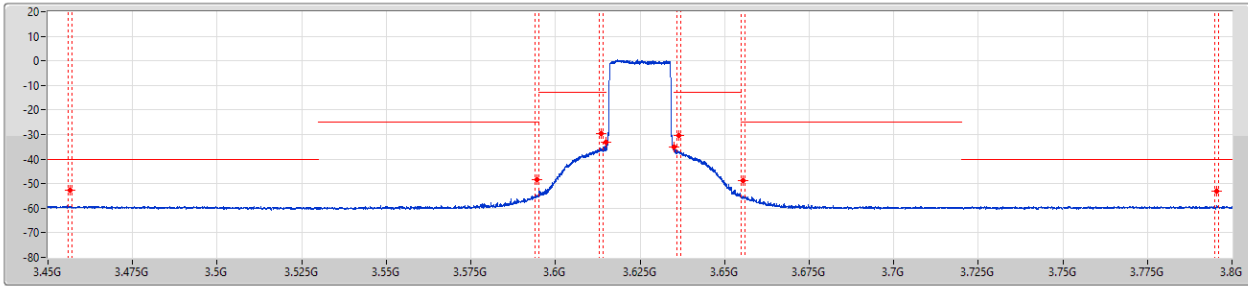

F-Start(Hz)	F-Stop(Hz)	RBW(Hz)	VBW(Hz)	Detector	Freq(Hz)	Level(dBm)	Limit(dBm)	Margin(dB)	Remark	Ref.Limit(dB)
3.45G	3.53G	200k	1M	RMS	3.4565G	-52.78	-40.00	-12.78	MBW 1M	-
3.53G	3.595G	200k	1M	RMS	3.5945G	-48.34	-25.00	-23.34	MBW 1M	-
3.595G	3.614G	200k	1M	RMS	3.6135G	-29.53	-13.00	-16.53	MBW 1M	-
3.614G	3.615G	200k	1M	RMS	3.61494G	-33.27	-13.00	-20.27	-	-
3.635G	3.636G	200k	1M	RMS	3.63504G	-35.05	-13.00	-22.05	-	-
3.636G	3.655G	200k	1M	RMS	3.6365G	-30.51	-13.00	-17.51	MBW 1M	-
3.655G	3.72G	200k	1M	RMS	3.6555G	-48.90	-25.00	-23.90	MBW 1M	-
3.72G	3.8G	200k	1M	RMS	3.7955G	-52.86	-40.00	-12.86	MBW 1M	-

Band 48\_LTE\_20MHz\_Nss1,64QAM\_1TX  
3625MHz\_64QAM\_RB 1,#RB L

CSE-TX-Sum

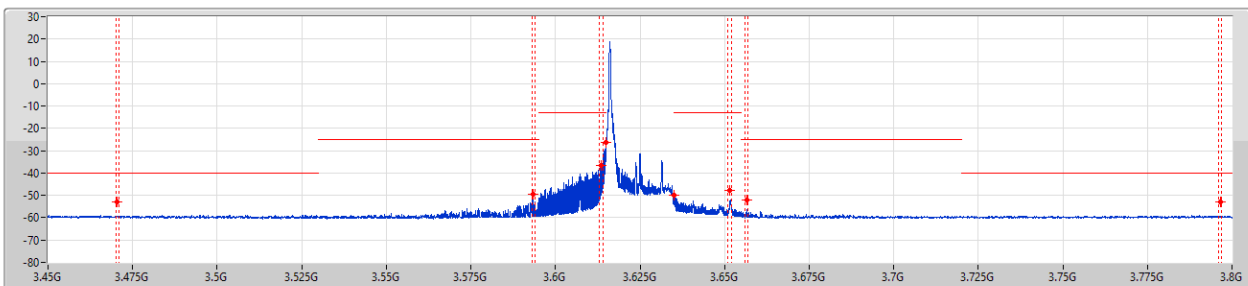

F-Start(Hz)	F-Stop(Hz)	RBW(Hz)	VBW(Hz)	Detector	Freq(Hz)	Level(dBm)	Limit(dBm)	Margin(dB)	Remark	Ref.Limit(dB)
3.45G	3.53G	200k	1M	RMS	3.4705G	-52.77	-40.00	-12.77	MBW 1M	-
3.53G	3.595G	200k	1M	RMS	3.5935G	-49.66	-25.00	-24.66	MBW 1M	-
3.595G	3.614G	200k	1M	RMS	3.6135G	-36.47	-13.00	-23.47	MBW 1M	-
3.614G	3.615G	200k	1M	RMS	3.61496G	-26.21	-13.00	-13.21	-	-
3.635G	3.636G	200k	1M	RMS	3.63517G	-49.81	-13.00	-36.81	-	-
3.636G	3.655G	200k	1M	RMS	3.6515G	-47.79	-13.00	-34.79	MBW 1M	-
3.655G	3.72G	200k	1M	RMS	3.6565G	-52.10	-25.00	-27.10	MBW 1M	-
3.72G	3.8G	200k	1M	RMS	3.7965G	-52.82	-40.00	-12.82	MBW 1M	-



Band 48\_LTE\_20MHz\_Nss1,64QAM\_1TX  
3690MHz\_64QAM\_RB 100,#RB 0

CSE-TX-Sum

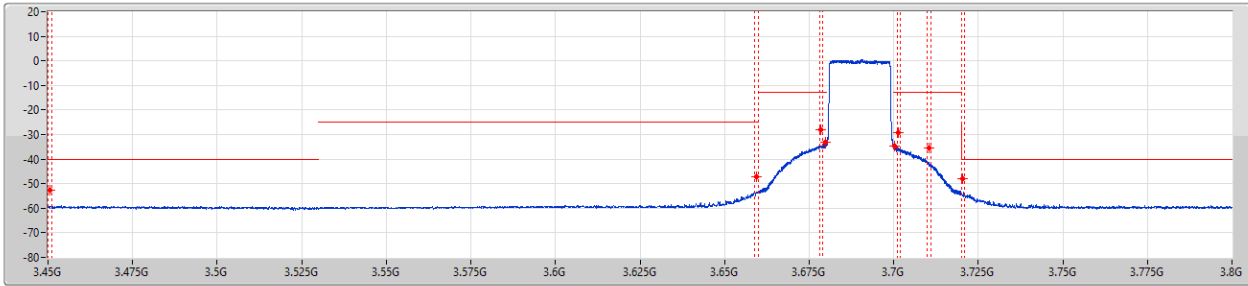

F-Start(Hz)	F-Stop(Hz)	RBW(Hz)	VBW(Hz)	Detector	Freq(Hz)	Level(dBm)	Limit(dBm)	Margin(dB)	Remark	Ref.Limit(dB)
3.45G	3.53G	200k	1M	RMS	3.4505G	-52.77	-40.00	-12.77	MBW 1M	-
3.53G	3.66G	200k	1M	RMS	3.6595G	-47.17	-25.00	-22.17	MBW 1M	-
3.66G	3.679G	200k	1M	RMS	3.6785G	-28.20	-13.00	-15.20	MBW 1M	-
3.679G	3.68G	200k	1M	RMS	3.67986G	-33.30	-13.00	-20.30	-	-
3.7G	3.701G	200k	1M	RMS	3.70012G	-34.59	-13.00	-21.59	-	-
3.701G	3.71G	200k	1M	RMS	3.7015G	-29.41	-13.00	-16.41	MBW 1M	-
3.71G	3.72G	200k	1M	RMS	3.7105G	-35.49	-13.00	-22.49	MBW 1M	-
3.72G	3.8G	200k	1M	RMS	3.7205G	-47.83	-40.00	-7.83	MBW 1M	-

Band 48\_LTE\_20MHz\_Nss1,64QAM\_1TX  
3690MHz\_64QAM\_RB 1,#RB R

CSE-TX-Sum

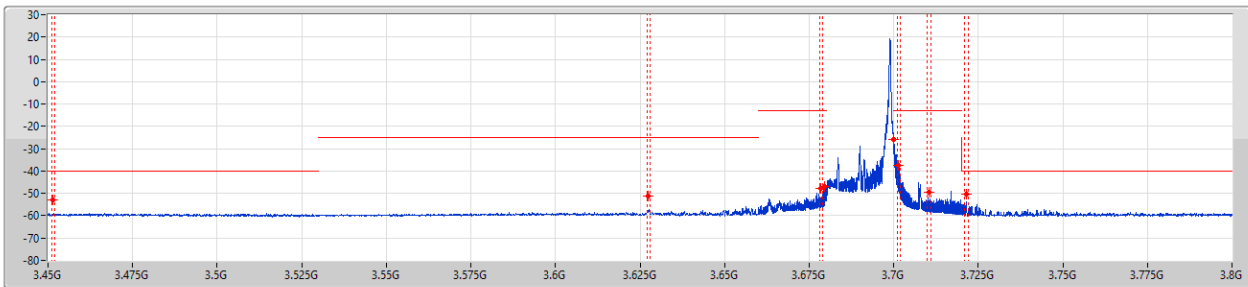

F-Start(Hz)	F-Stop(Hz)	RBW(Hz)	VBW(Hz)	Detector	Freq(Hz)	Level(dBm)	Limit(dBm)	Margin(dB)	Remark	Ref.Limit(dB)
3.45G	3.53G	200k	1M	RMS	3.4515G	-52.77	-40.00	-12.77	MBW 1M	-
3.53G	3.66G	200k	1M	RMS	3.6275G	-51.31	-25.00	-26.31	MBW 1M	-
3.66G	3.679G	200k	1M	RMS	3.6785G	-47.62	-13.00	-34.62	MBW 1M	-
3.679G	3.68G	200k	1M	RMS	3.67951G	-47.12	-13.00	-34.12	-	-
3.7G	3.701G	200k	1M	RMS	3.70001G	-25.89	-13.00	-12.89	-	-
3.701G	3.71G	200k	1M	RMS	3.7015G	-37.29	-13.00	-24.29	MBW 1M	-
3.71G	3.72G	200k	1M	RMS	3.7105G	-49.45	-13.00	-36.45	MBW 1M	-
3.72G	3.8G	200k	1M	RMS	3.7215G	-50.47	-40.00	-10.47	MBW 1M	-



Band 48\_LTE\_20MHz\_Nss1,256QAM\_1TX  
3560MHz\_256QAM\_RB 100,#RB 0

CSE-TX-Sum

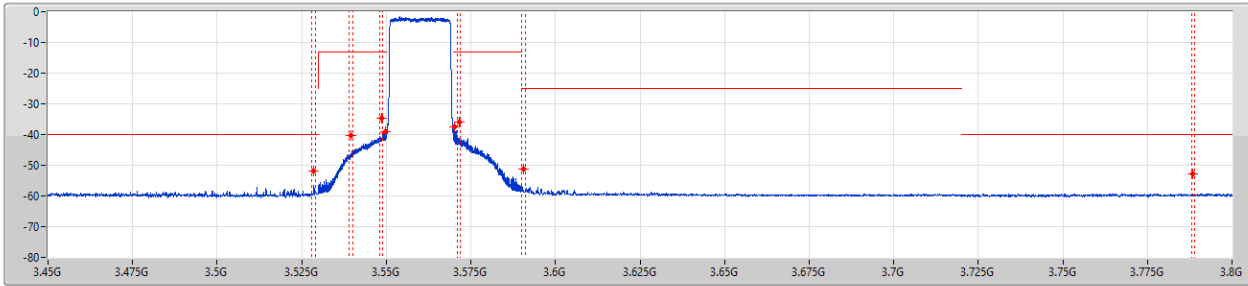

F-Start(Hz)	F-Stop(Hz)	RBW(Hz)	VBW(Hz)	Detector	Freq(Hz)	Level(dBm)	Limit(dBm)	Margin(dB)	Remark	Ref.Limit(dB)
3.45G	3.53G	200k	1M	RMS	3.5285G	-51.97	-40.00	-11.97	MBW 1M	-
3.53G	3.54G	200k	1M	RMS	3.5395G	-40.24	-13.00	-27.24	MBW 1M	-
3.54G	3.549G	200k	1M	RMS	3.5485G	-34.82	-13.00	-21.82	MBW 1M	-
3.549G	3.55G	200k	1M	RMS	3.54988G	-38.97	-13.00	-25.97	-	-
3.57G	3.571G	200k	1M	RMS	3.57003G	-37.38	-13.00	-24.38	-	-
3.571G	3.59G	200k	1M	RMS	3.5715G	-35.86	-13.00	-22.86	MBW 1M	-
3.59G	3.72G	200k	1M	RMS	3.5905G	-51.37	-25.00	-26.37	MBW 1M	-
3.72G	3.8G	200k	1M	RMS	3.7885G	-52.88	-40.00	-12.88	MBW 1M	-

Band 48\_LTE\_20MHz\_Nss1,256QAM\_1TX  
3560MHz\_256QAM\_RB 1,#RB L

CSE-TX-Sum

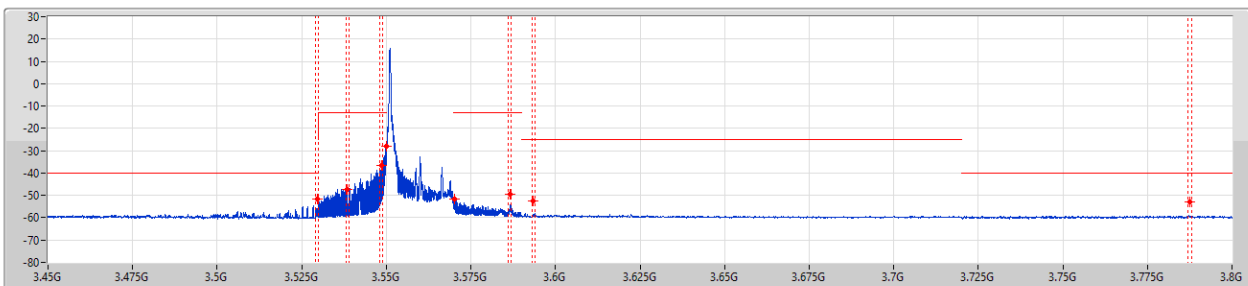

F-Start(Hz)	F-Stop(Hz)	RBW(Hz)	VBW(Hz)	Detector	Freq(Hz)	Level(dBm)	Limit(dBm)	Margin(dB)	Remark	Ref.Limit(dB)
3.45G	3.53G	200k	1M	RMS	3.5295G	-51.68	-40.00	-11.68	MBW 1M	-
3.53G	3.54G	200k	1M	RMS	3.5385G	-47.34	-13.00	-34.34	MBW 1M	-
3.54G	3.549G	200k	1M	RMS	3.5485G	-36.53	-13.00	-23.53	MBW 1M	-
3.549G	3.55G	200k	1M	RMS	3.54996G	-28.11	-13.00	-15.11	-	-
3.57G	3.571G	200k	1M	RMS	3.57022G	-51.52	-13.00	-38.52	-	-
3.571G	3.59G	200k	1M	RMS	3.5865G	-49.54	-13.00	-36.54	MBW 1M	-
3.59G	3.72G	200k	1M	RMS	3.5935G	-52.30	-25.00	-27.30	MBW 1M	-
3.72G	3.8G	200k	1M	RMS	3.7875G	-52.83	-40.00	-12.83	MBW 1M	-





Band 48\_LTE\_20MHz\_Nss1,256QAM\_1TX  
3625MHz\_256QAM\_RB 100,#RB 0

CSE-TX-Sum

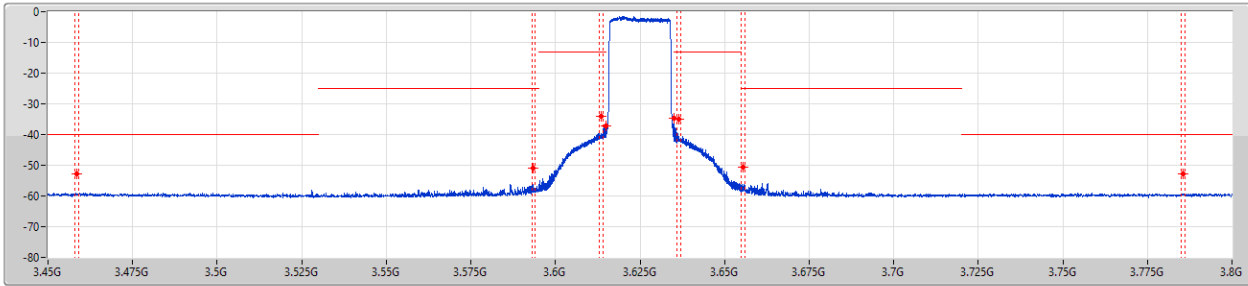

F-Start(Hz)	F-Stop(Hz)	RBW(Hz)	VBW(Hz)	Detector	Freq(Hz)	Level(dBm)	Limit(dBm)	Margin(dB)	Remark	Ref.Limit(dB)
3.45G	3.53G	200k	1M	RMS	3.4585G	-52.75	-40.00	-12.75	MBW 1M	-
3.53G	3.595G	200k	1M	RMS	3.5935G	-50.81	-25.00	-25.81	MBW 1M	-
3.595G	3.614G	200k	1M	RMS	3.6135G	-33.98	-13.00	-20.98	MBW 1M	-
3.614G	3.615G	200k	1M	RMS	3.61485G	-37.15	-13.00	-24.15	-	-
3.635G	3.636G	200k	1M	RMS	3.63513G	-34.72	-13.00	-21.72	-	-
3.636G	3.655G	200k	1M	RMS	3.6365G	-34.99	-13.00	-21.99	MBW 1M	-
3.655G	3.72G	200k	1M	RMS	3.6555G	-50.73	-25.00	-25.73	MBW 1M	-
3.72G	3.8G	200k	1M	RMS	3.7855G	-52.78	-40.00	-12.78	MBW 1M	-

Band 48\_LTE\_20MHz\_Nss1,256QAM\_1TX  
3625MHz\_256QAM\_RB 1,#RB L

CSE-TX-Sum

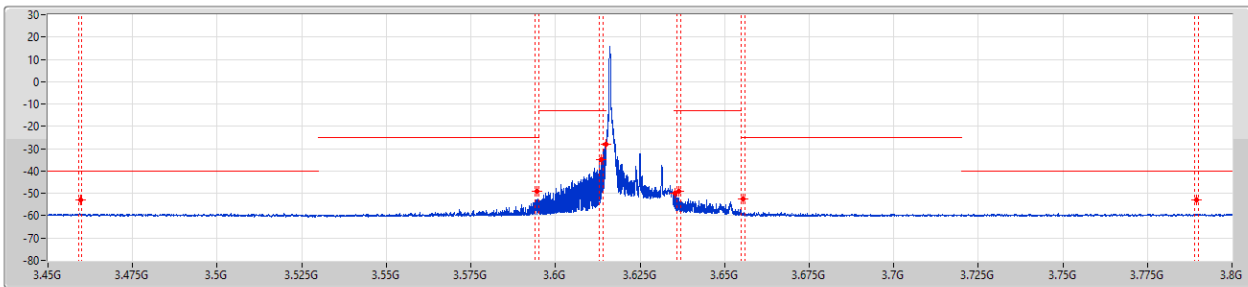

F-Start(Hz)	F-Stop(Hz)	RBW(Hz)	VBW(Hz)	Detector	Freq(Hz)	Level(dBm)	Limit(dBm)	Margin(dB)	Remark	Ref.Limit(dB)
3.45G	3.53G	200k	1M	RMS	3.4595G	-52.74	-40.00	-12.74	MBW 1M	-
3.53G	3.595G	200k	1M	RMS	3.5945G	-48.89	-25.00	-23.89	MBW 1M	-
3.595G	3.614G	200k	1M	RMS	3.6135G	-35.03	-13.00	-22.03	MBW 1M	-
3.614G	3.615G	200k	1M	RMS	3.61492G	-27.83	-13.00	-14.83	-	-
3.635G	3.636G	200k	1M	RMS	3.63532G	-50.03	-13.00	-37.03	-	-
3.636G	3.655G	200k	1M	RMS	3.6365G	-48.91	-13.00	-35.91	MBW 1M	-
3.655G	3.72G	200k	1M	RMS	3.6555G	-52.61	-25.00	-27.61	MBW 1M	-
3.72G	3.8G	200k	1M	RMS	3.7895G	-52.88	-40.00	-12.88	MBW 1M	-



Band 48\_LTE\_20MHz\_Nss1,256QAM\_1TX  
3690MHz\_256QAM\_RB 100,#RB 0

CSE-TX-Sum

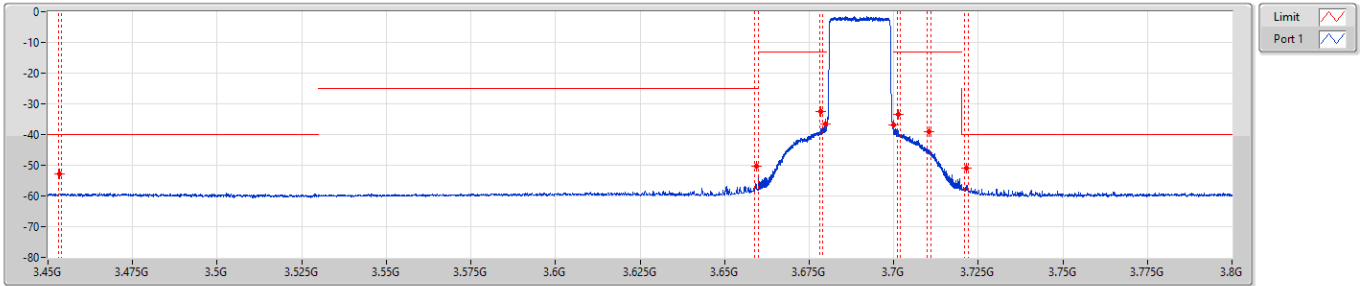

F-Start(Hz)	F-Stop(Hz)	RBW(Hz)	VBW(Hz)	Detector	Freq(Hz)	Level(dBm)	Limit(dBm)	Margin(dB)	Remark	Ref.Limit(dB)
3.45G	3.53G	200k	1M	RMS	3.4535G	-52.80	-40.00	-12.80	MBW 1M	-
3.53G	3.66G	200k	1M	RMS	3.6595G	-50.43	-25.00	-25.43	MBW 1M	-
3.66G	3.679G	200k	1M	RMS	3.6785G	-32.59	-13.00	-19.59	MBW 1M	-
3.679G	3.68G	200k	1M	RMS	3.67971G	-36.46	-13.00	-23.46	-	-
3.7G	3.701G	200k	1M	RMS	3.70008G	-36.75	-13.00	-23.75	-	-
3.701G	3.71G	200k	1M	RMS	3.7015G	-33.40	-13.00	-20.40	MBW 1M	-
3.71G	3.72G	200k	1M	RMS	3.7105G	-39.07	-13.00	-26.07	MBW 1M	-
3.72G	3.8G	200k	1M	RMS	3.7215G	-50.98	-40.00	-10.98	MBW 1M	-

Band 48\_LTE\_20MHz\_Nss1,256QAM\_1TX  
3690MHz\_256QAM\_RB 1,#RB R

CSE-TX-Sum

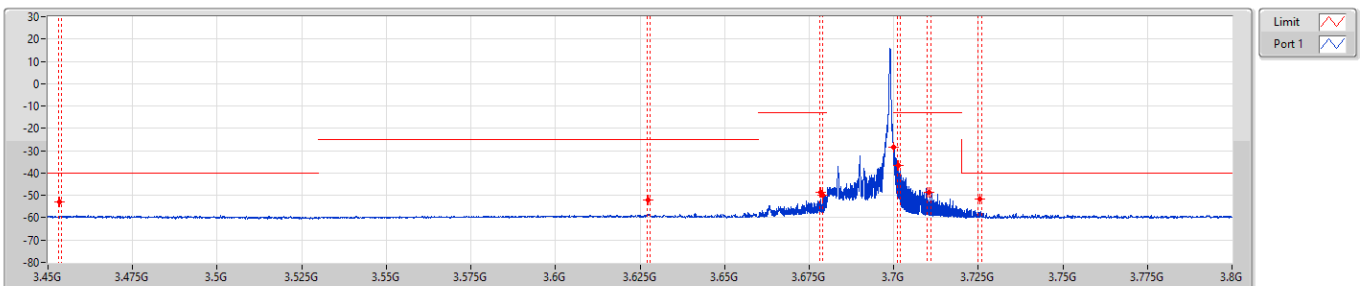

F-Start(Hz)	F-Stop(Hz)	RBW(Hz)	VBW(Hz)	Detector	Freq(Hz)	Level(dBm)	Limit(dBm)	Margin(dB)	Remark	Ref.Limit(dB)
3.45G	3.53G	200k	1M	RMS	3.4535G	-52.77	-40.00	-12.77	MBW 1M	-
3.53G	3.66G	200k	1M	RMS	3.6275G	-52.11	-25.00	-27.11	MBW 1M	-
3.66G	3.679G	200k	1M	RMS	3.6785G	-48.62	-13.00	-35.62	MBW 1M	-
3.679G	3.68G	200k	1M	RMS	3.67905G	-49.89	-13.00	-36.89	-	-
3.7G	3.701G	200k	1M	RMS	3.70004G	-28.35	-13.00	-15.35	-	-
3.701G	3.71G	200k	1M	RMS	3.7015G	-36.77	-13.00	-23.77	MBW 1M	-
3.71G	3.72G	200k	1M	RMS	3.7105G	-48.70	-13.00	-35.70	MBW 1M	-
3.72G	3.8G	200k	1M	RMS	3.7255G	-51.73	-40.00	-11.73	MBW 1M	-



Band 48\_LTE\_15MHz\_Nss1,QPSK\_1TX  
3557.5MHz\_QPSK\_RB 75,#RB 0

CSE-TX-Sum

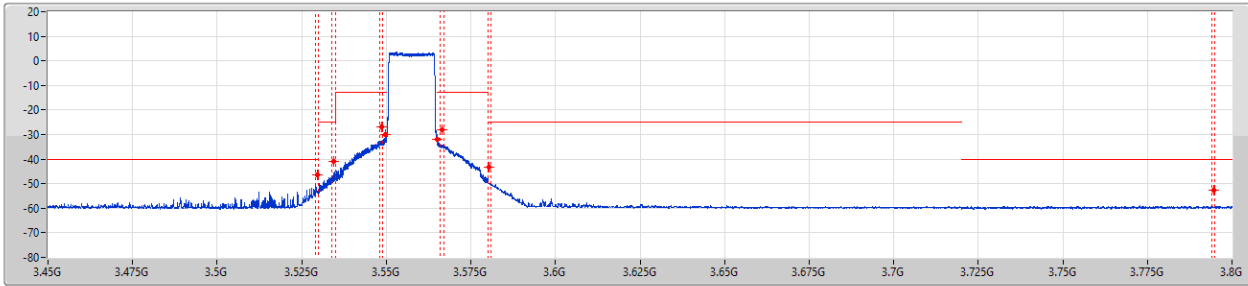

F-Start(Hz)	F-Stop(Hz)	RBW(Hz)	VBW(Hz)	Detector	Freq(Hz)	Level(dBm)	Limit(dBm)	Margin(dB)	Remark	Ref.Limit(dB)
3.45G	3.53G	200k	1M	RMS	3.5295G	-46.23	-40.00	-6.23	MBW 1M	-
3.53G	3.54G	200k	1M	RMS	3.5345G	-40.87	-25.00	-15.87	MBW 1M	-
3.54G	3.549G	200k	1M	RMS	3.5485G	-26.89	-13.00	-13.89	MBW 1M	-
3.549G	3.55G	200k	1M	RMS	3.54983G	-29.91	-13.00	-16.91	-	-
3.565G	3.566G	200k	1M	RMS	3.5651G	-32.14	-13.00	-19.14	-	-
3.566G	3.58G	200k	1M	RMS	3.5665G	-28.07	-13.00	-15.07	MBW 1M	-
3.58G	3.72G	200k	1M	RMS	3.5805G	-43.21	-25.00	-18.21	MBW 1M	-
3.72G	3.8G	200k	1M	RMS	3.7945G	-52.80	-40.00	-12.80	MBW 1M	-

Band 48\_LTE\_15MHz\_Nss1,QPSK\_1TX  
3557.5MHz\_QPSK\_RB 1,#RB L

CSE-TX-Sum

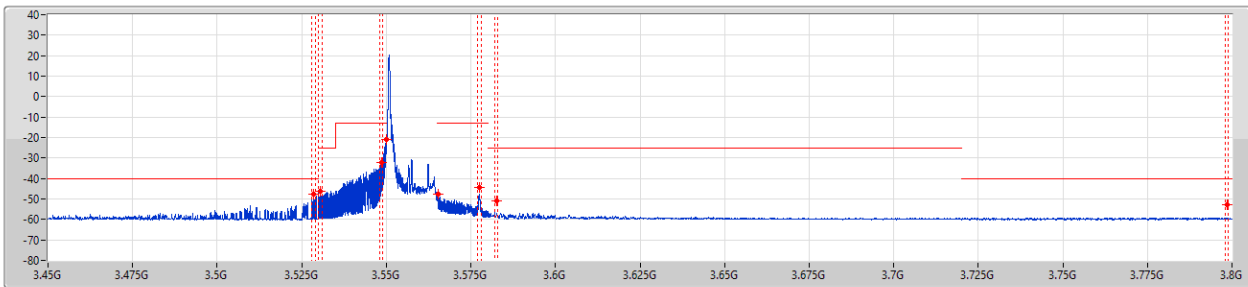

F-Start(Hz)	F-Stop(Hz)	RBW(Hz)	VBW(Hz)	Detector	Freq(Hz)	Level(dBm)	Limit(dBm)	Margin(dB)	Remark	Ref.Limit(dB)
3.45G	3.53G	200k	1M	RMS	3.5285G	-47.47	-40.00	-7.47	MBW 1M	-
3.53G	3.54G	200k	1M	RMS	3.5305G	-46.13	-25.00	-21.13	MBW 1M	-
3.54G	3.549G	200k	1M	RMS	3.5485G	-32.03	-13.00	-19.03	MBW 1M	-
3.549G	3.55G	200k	1M	RMS	3.55G	-20.82	-13.00	-7.82	-	-
3.565G	3.566G	200k	1M	RMS	3.56521G	-47.49	-13.00	-34.49	-	-
3.566G	3.58G	200k	1M	RMS	3.5775G	-44.19	-13.00	-31.19	MBW 1M	-
3.58G	3.72G	200k	1M	RMS	3.5825G	-51.08	-25.00	-26.08	MBW 1M	-
3.72G	3.8G	200k	1M	RMS	3.7985G	-52.84	-40.00	-12.84	MBW 1M	-



Band 48\_LTE\_15MHz\_Nss1,QPSK\_1TX  
3625MHz\_QPSK\_RB 75,#RB 0

CSE-TX-Sum

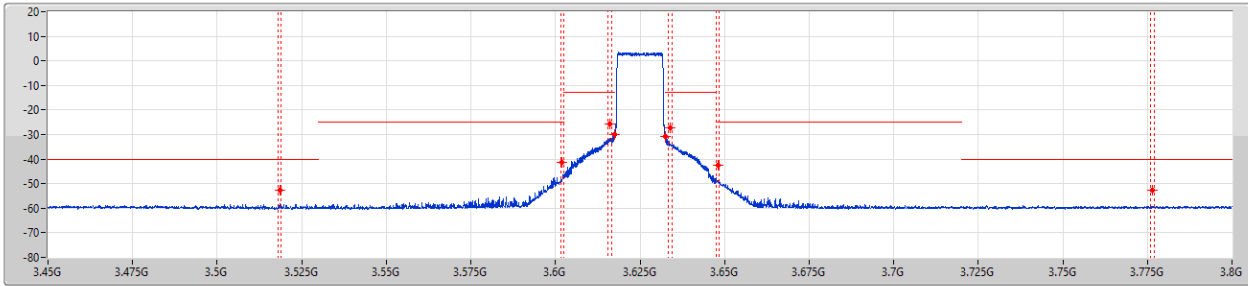

Limit   
Port 1

F-Start(Hz)	F-Stop(Hz)	RBW(Hz)	VBW(Hz)	Detector	Freq(Hz)	Level(dBm)	Limit(dBm)	Margin(dB)	Remark	Ref.Limit(dB)
3.45G	3.53G	200k	1M	RMS	3.5185G	-52.59	-40.00	-12.59	MBW 1M	-
3.53G	3.6025G	200k	1M	RMS	3.602G	-41.32	-25.00	-16.32	MBW 1M	-
3.6025G	3.6165G	200k	1M	RMS	3.616G	-25.76	-13.00	-12.76	MBW 1M	-
3.6165G	3.6175G	200k	1M	RMS	3.61746G	-29.98	-13.00	-16.98	-	-
3.6325G	3.6335G	200k	1M	RMS	3.63255G	-30.89	-13.00	-17.89	-	-
3.6335G	3.6475G	200k	1M	RMS	3.634G	-27.42	-13.00	-14.42	MBW 1M	-
3.6475G	3.72G	200k	1M	RMS	3.648G	-42.39	-25.00	-17.39	MBW 1M	-
3.72G	3.8G	200k	1M	RMS	3.7765G	-52.79	-40.00	-12.79	MBW 1M	-

Band 48\_LTE\_15MHz\_Nss1,QPSK\_1TX  
3625MHz\_QPSK\_RB 1,#RB L

CSE-TX-Sum

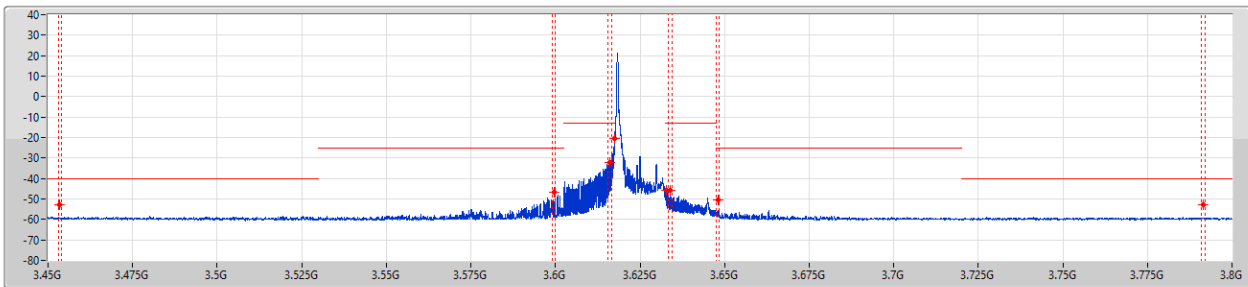

Limit   
Port 1

F-Start(Hz)	F-Stop(Hz)	RBW(Hz)	VBW(Hz)	Detector	Freq(Hz)	Level(dBm)	Limit(dBm)	Margin(dB)	Remark	Ref.Limit(dB)
3.45G	3.53G	200k	1M	RMS	3.4535G	-52.61	-40.00	-12.61	MBW 1M	-
3.53G	3.6025G	200k	1M	RMS	3.5995G	-46.79	-25.00	-21.79	MBW 1M	-
3.6025G	3.6165G	200k	1M	RMS	3.616G	-32.18	-13.00	-19.18	MBW 1M	-
3.6165G	3.6175G	200k	1M	RMS	3.6175G	-20.69	-13.00	-7.69	-	-
3.6325G	3.6335G	200k	1M	RMS	3.63271G	-45.55	-13.00	-32.55	-	-
3.6335G	3.6475G	200k	1M	RMS	3.634G	-45.81	-13.00	-32.81	MBW 1M	-
3.6475G	3.72G	200k	1M	RMS	3.648G	-50.70	-25.00	-25.70	MBW 1M	-
3.72G	3.8G	200k	1M	RMS	3.7915G	-52.79	-40.00	-12.79	MBW 1M	-



Band 48\_LTE\_15MHz\_Nss1,QPSK\_1TX  
3692.5MHz\_QPSK\_RB 75,#RB 0

CSE-TX-Sum

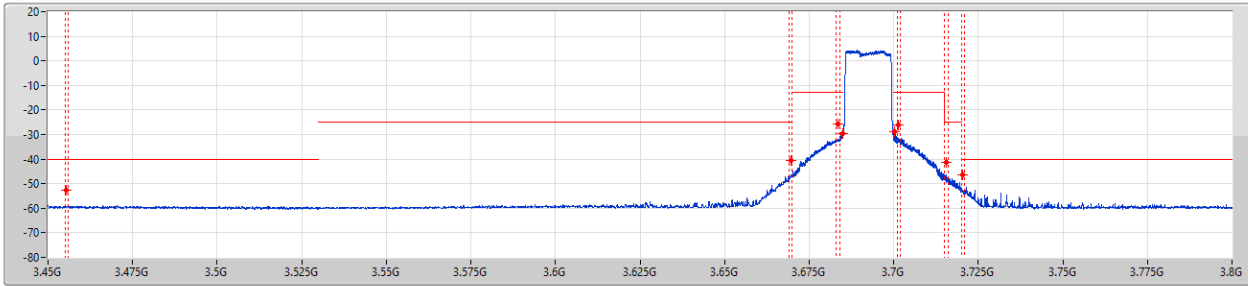

F-Start(Hz)	F-Stop(Hz)	RBW(Hz)	VBW(Hz)	Detector	Freq(Hz)	Level(dBm)	Limit(dBm)	Margin(dB)	Remark	Ref.Limit(dB)
3.45G	3.53G	200k	1M	RMS	3.4555G	-52.74	-40.00	-12.74	MBW 1M	-
3.53G	3.67G	200k	1M	RMS	3.6695G	-40.66	-25.00	-15.66	MBW 1M	-
3.67G	3.684G	200k	1M	RMS	3.6835G	-25.70	-13.00	-12.70	MBW 1M	-
3.684G	3.685G	200k	1M	RMS	3.68486G	-29.73	-13.00	-16.73	-	-
3.7G	3.701G	200k	1M	RMS	3.70025G	-28.91	-13.00	-15.91	-	-
3.701G	3.71G	200k	1M	RMS	3.7015G	-25.99	-13.00	-12.99	MBW 1M	-
3.71G	3.72G	200k	1M	RMS	3.7155G	-41.42	-25.00	-16.42	MBW 1M	-
3.72G	3.8G	200k	1M	RMS	3.7205G	-46.50	-40.00	-6.50	MBW 1M	-

Band 48\_LTE\_15MHz\_Nss1,QPSK\_1TX  
3692.5MHz\_QPSK\_RB 1,#RB R

CSE-TX-Sum

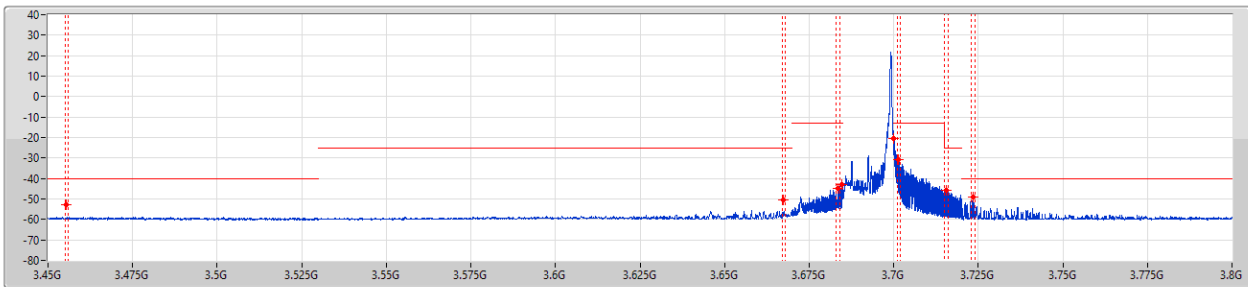

F-Start(Hz)	F-Stop(Hz)	RBW(Hz)	VBW(Hz)	Detector	Freq(Hz)	Level(dBm)	Limit(dBm)	Margin(dB)	Remark	Ref.Limit(dB)
3.45G	3.53G	200k	1M	RMS	3.4555G	-52.72	-40.00	-12.72	MBW 1M	-
3.53G	3.67G	200k	1M	RMS	3.6675G	-50.68	-25.00	-25.68	MBW 1M	-
3.67G	3.684G	200k	1M	RMS	3.6835G	-44.90	-13.00	-31.90	MBW 1M	-
3.684G	3.685G	200k	1M	RMS	3.68458G	-42.86	-13.00	-29.86	-	-
3.7G	3.701G	200k	1M	RMS	3.70001G	-20.64	-13.00	-7.64	-	-
3.701G	3.71G	200k	1M	RMS	3.7015G	-30.64	-13.00	-17.64	MBW 1M	-
3.71G	3.72G	200k	1M	RMS	3.7155G	-45.59	-25.00	-20.59	MBW 1M	-
3.72G	3.8G	200k	1M	RMS	3.7235G	-49.02	-40.00	-9.02	MBW 1M	-



Band 48\_LTE\_15MHz\_Nss1,16QAM\_1TX  
3557.5MHz\_16QAM\_RB 75,#RB 0

CSE-TX-Sum

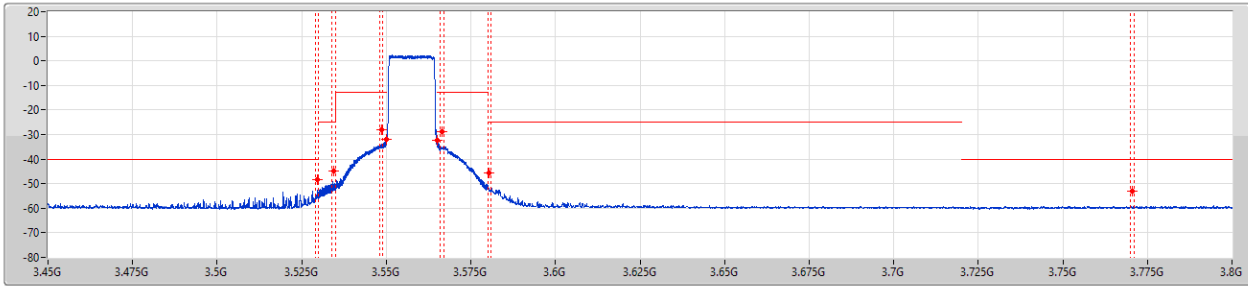

F-Start(Hz)	F-Stop(Hz)	RBW(Hz)	VBW(Hz)	Detector	Freq(Hz)	Level(dBm)	Limit(dBm)	Margin(dB)	Remark	Ref.Limit(dB)
3.45G	3.53G	200k	1M	RMS	3.5295G	-48.43	-40.00	-8.43	MBW 1M	-
3.53G	3.54G	200k	1M	RMS	3.5345G	-44.76	-25.00	-19.76	MBW 1M	-
3.54G	3.549G	200k	1M	RMS	3.5485G	-28.14	-13.00	-15.14	MBW 1M	-
3.549G	3.55G	200k	1M	RMS	3.54997G	-31.90	-13.00	-18.90	-	-
3.565G	3.566G	200k	1M	RMS	3.56501G	-32.46	-13.00	-19.46	-	-
3.566G	3.58G	200k	1M	RMS	3.5665G	-28.64	-13.00	-15.64	MBW 1M	-
3.58G	3.72G	200k	1M	RMS	3.5805G	-45.77	-25.00	-20.77	MBW 1M	-
3.72G	3.8G	200k	1M	RMS	3.7705G	-52.88	-40.00	-12.88	MBW 1M	-

Band 48\_LTE\_15MHz\_Nss1,16QAM\_1TX  
3557.5MHz\_16QAM\_RB 1,#RB L

CSE-TX-Sum

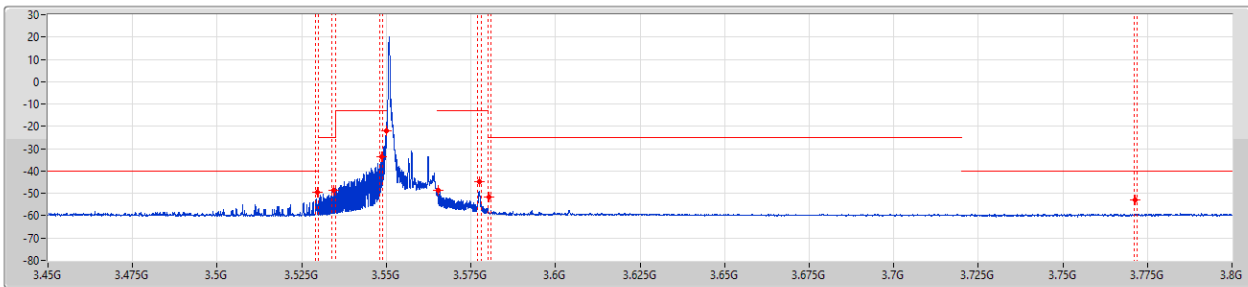

F-Start(Hz)	F-Stop(Hz)	RBW(Hz)	VBW(Hz)	Detector	Freq(Hz)	Level(dBm)	Limit(dBm)	Margin(dB)	Remark	Ref.Limit(dB)
3.45G	3.53G	200k	1M	RMS	3.5295G	-49.48	-40.00	-9.48	MBW 1M	-
3.53G	3.54G	200k	1M	RMS	3.5345G	-48.45	-25.00	-23.45	MBW 1M	-
3.54G	3.549G	200k	1M	RMS	3.5485G	-33.55	-13.00	-20.55	MBW 1M	-
3.549G	3.55G	200k	1M	RMS	3.54998G	-22.07	-13.00	-9.07	-	-
3.565G	3.566G	200k	1M	RMS	3.56523G	-48.50	-13.00	-35.50	-	-
3.566G	3.58G	200k	1M	RMS	3.5775G	-44.89	-13.00	-31.89	MBW 1M	-
3.58G	3.72G	200k	1M	RMS	3.5805G	-51.74	-25.00	-26.74	MBW 1M	-
3.72G	3.8G	200k	1M	RMS	3.7715G	-52.85	-40.00	-12.85	MBW 1M	-



Band 48\_LTE\_15MHz\_Nss1,16QAM\_1TX  
3625MHz\_16QAM\_RB 75,#RB 0

CSE-TX-Sum

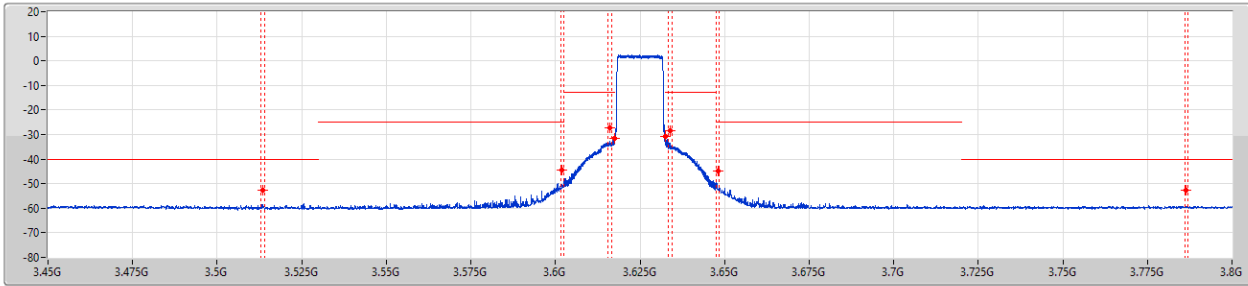

Limit   
Port 1

F-Start(Hz)	F-Stop(Hz)	RBW(Hz)	VBW(Hz)	Detector	Freq(Hz)	Level(dBm)	Limit(dBm)	Margin(dB)	Remark	Ref.Limit(dB)
3.45G	3.53G	200k	1M	RMS	3.5135G	-52.73	-40.00	-12.73	MBW 1M	-
3.53G	3.6025G	200k	1M	RMS	3.602G	-44.62	-25.00	-19.62	MBW 1M	-
3.6025G	3.6165G	200k	1M	RMS	3.616G	-27.13	-13.00	-14.13	MBW 1M	-
3.6165G	3.6175G	200k	1M	RMS	3.61746G	-31.63	-13.00	-18.63	-	-
3.6325G	3.6335G	200k	1M	RMS	3.63254G	-30.84	-13.00	-17.84	-	-
3.6335G	3.6475G	200k	1M	RMS	3.634G	-28.27	-13.00	-15.27	MBW 1M	-
3.6475G	3.72G	200k	1M	RMS	3.648G	-45.01	-25.00	-20.01	MBW 1M	-
3.72G	3.8G	200k	1M	RMS	3.7865G	-52.77	-40.00	-12.77	MBW 1M	-

Band 48\_LTE\_15MHz\_Nss1,16QAM\_1TX  
3625MHz\_16QAM\_RB 1,#RB L

CSE-TX-Sum

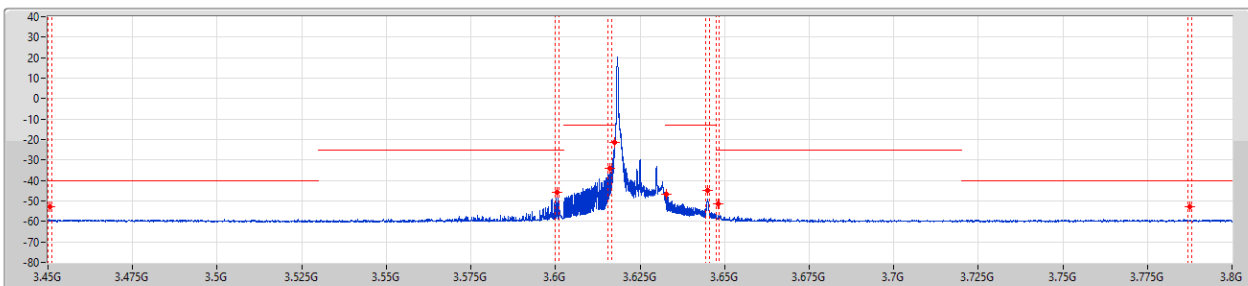

Limit   
Port 1

F-Start(Hz)	F-Stop(Hz)	RBW(Hz)	VBW(Hz)	Detector	Freq(Hz)	Level(dBm)	Limit(dBm)	Margin(dB)	Remark	Ref.Limit(dB)
3.45G	3.53G	200k	1M	RMS	3.4505G	-52.69	-40.00	-12.69	MBW 1M	-
3.53G	3.6025G	200k	1M	RMS	3.6005G	-45.97	-25.00	-20.97	MBW 1M	-
3.6025G	3.6165G	200k	1M	RMS	3.616G	-34.27	-13.00	-21.27	MBW 1M	-
3.6165G	3.6175G	200k	1M	RMS	3.61748G	-21.22	-13.00	-8.22	-	-
3.6325G	3.6335G	200k	1M	RMS	3.63267G	-46.91	-13.00	-33.91	-	-
3.6335G	3.6475G	200k	1M	RMS	3.645G	-45.02	-13.00	-32.02	MBW 1M	-
3.6475G	3.72G	200k	1M	RMS	3.648G	-51.49	-25.00	-26.49	MBW 1M	-
3.72G	3.8G	200k	1M	RMS	3.7875G	-52.80	-40.00	-12.80	MBW 1M	-



Band 48\_LTE\_15MHz\_Nss1,16QAM\_1TX  
3692.5MHz\_16QAM\_RB 75,#RB 0

CSE-TX-Sum

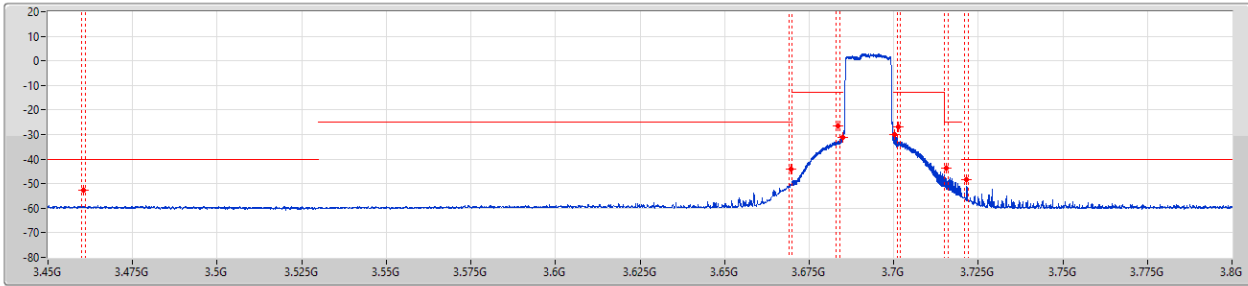

F-Start(Hz)	F-Stop(Hz)	RBW(Hz)	VBW(Hz)	Detector	Freq(Hz)	Level(dBm)	Limit(dBm)	Margin(dB)	Remark	Ref.Limit(dB)
3.45G	3.53G	200k	1M	RMS	3.4605G	-52.75	-40.00	-12.75	MBW 1M	-
3.53G	3.67G	200k	1M	RMS	3.6695G	-44.08	-25.00	-19.08	MBW 1M	-
3.67G	3.684G	200k	1M	RMS	3.6835G	-26.58	-13.00	-13.58	MBW 1M	-
3.684G	3.685G	200k	1M	RMS	3.685G	-31.10	-13.00	-18.10	-	-
3.7G	3.701G	200k	1M	RMS	3.70033G	-30.00	-13.00	-17.00	-	-
3.701G	3.71G	200k	1M	RMS	3.7015G	-27.06	-13.00	-14.06	MBW 1M	-
3.71G	3.72G	200k	1M	RMS	3.7155G	-43.62	-25.00	-18.62	MBW 1M	-
3.72G	3.8G	200k	1M	RMS	3.7215G	-48.48	-40.00	-8.48	MBW 1M	-

Band 48\_LTE\_15MHz\_Nss1,16QAM\_1TX  
3692.5MHz\_16QAM\_RB 1,#RB R

CSE-TX-Sum

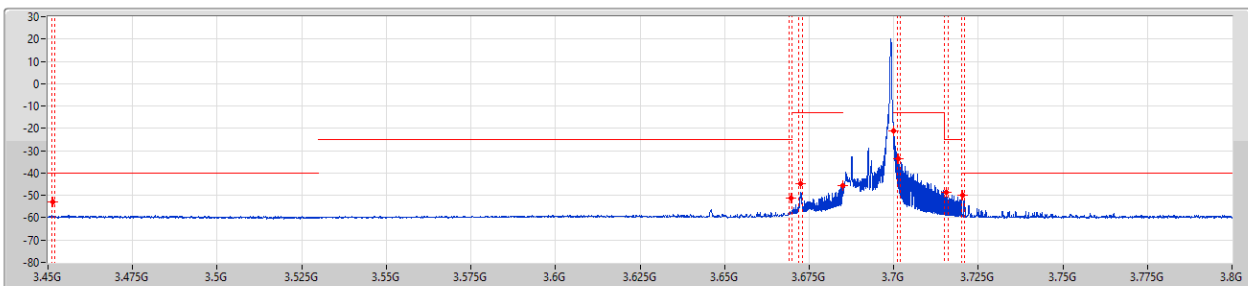

F-Start(Hz)	F-Stop(Hz)	RBW(Hz)	VBW(Hz)	Detector	Freq(Hz)	Level(dBm)	Limit(dBm)	Margin(dB)	Remark	Ref.Limit(dB)
3.45G	3.53G	200k	1M	RMS	3.4515G	-52.77	-40.00	-12.77	MBW 1M	-
3.53G	3.67G	200k	1M	RMS	3.6695G	-51.05	-25.00	-26.05	MBW 1M	-
3.67G	3.684G	200k	1M	RMS	3.6725G	-44.66	-13.00	-31.66	MBW 1M	-
3.684G	3.685G	200k	1M	RMS	3.68497G	-45.50	-13.00	-32.50	-	-
3.7G	3.701G	200k	1M	RMS	3.70002G	-21.23	-13.00	-8.23	-	-
3.701G	3.71G	200k	1M	RMS	3.7015G	-33.79	-13.00	-20.79	MBW 1M	-
3.71G	3.72G	200k	1M	RMS	3.7155G	-48.60	-25.00	-23.60	MBW 1M	-
3.72G	3.8G	200k	1M	RMS	3.7205G	-49.98	-40.00	-9.98	MBW 1M	-





Band 48\_LTE\_15MHz\_Nss1,64QAM\_1TX  
3557.5MHz\_64QAM\_RB 75,#RB 0

CSE-TX-Sum

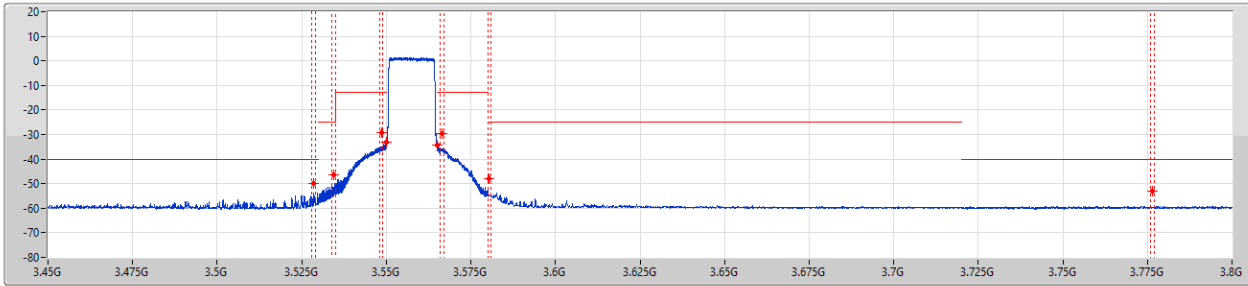

F-Start(Hz)	F-Stop(Hz)	RBW(Hz)	VBW(Hz)	Detector	Freq(Hz)	Level(dBm)	Limit(dBm)	Margin(dB)	Remark	Ref.Limit(dB)
3.45G	3.53G	200k	1M	RMS	3.5285G	-49.89	-40.00	-9.89	MBW 1M	-
3.53G	3.54G	200k	1M	RMS	3.5345G	-46.56	-25.00	-21.56	MBW 1M	-
3.54G	3.549G	200k	1M	RMS	3.5485G	-29.33	-13.00	-16.33	MBW 1M	-
3.549G	3.55G	200k	1M	RMS	3.54997G	-33.07	-13.00	-20.07	-	-
3.565G	3.566G	200k	1M	RMS	3.56502G	-34.12	-13.00	-21.12	-	-
3.566G	3.58G	200k	1M	RMS	3.5665G	-29.66	-13.00	-16.66	MBW 1M	-
3.58G	3.72G	200k	1M	RMS	3.5805G	-47.93	-25.00	-22.93	MBW 1M	-
3.72G	3.8G	200k	1M	RMS	3.7765G	-52.91	-40.00	-12.91	MBW 1M	-

Band 48\_LTE\_15MHz\_Nss1,64QAM\_1TX  
3557.5MHz\_64QAM\_RB 1,#RB L

CSE-TX-Sum

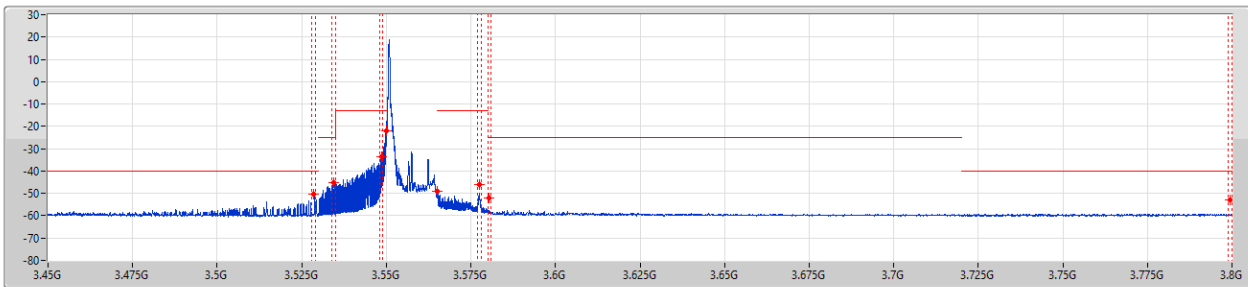

F-Start(Hz)	F-Stop(Hz)	RBW(Hz)	VBW(Hz)	Detector	Freq(Hz)	Level(dBm)	Limit(dBm)	Margin(dB)	Remark	Ref.Limit(dB)
3.45G	3.53G	200k	1M	RMS	3.5285G	-50.40	-40.00	-10.40	MBW 1M	-
3.53G	3.54G	200k	1M	RMS	3.5345G	-45.22	-25.00	-20.22	MBW 1M	-
3.54G	3.549G	200k	1M	RMS	3.5485G	-33.39	-13.00	-20.39	MBW 1M	-
3.549G	3.55G	200k	1M	RMS	3.54999G	-22.04	-13.00	-9.04	-	-
3.565G	3.566G	200k	1M	RMS	3.56517G	-49.14	-13.00	-36.14	-	-
3.566G	3.58G	200k	1M	RMS	3.5775G	-46.01	-13.00	-33.01	MBW 1M	-
3.58G	3.72G	200k	1M	RMS	3.5805G	-51.88	-25.00	-26.88	MBW 1M	-
3.72G	3.8G	200k	1M	RMS	3.7995G	-52.86	-40.00	-12.86	MBW 1M	-



Band 48\_LTE\_15MHz\_Nss1,64QAM\_1TX  
3625MHz\_64QAM\_RB 75,#RB 0

CSE-TX-Sum

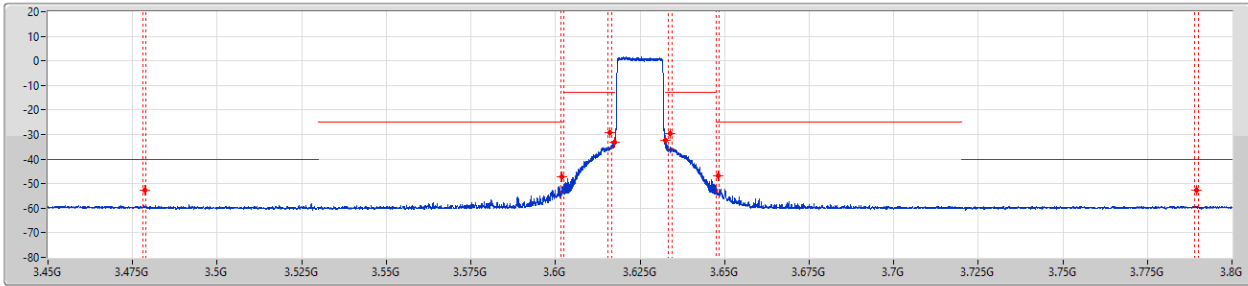

Limit

Port 1

F-Start(Hz)	F-Stop(Hz)	RBW(Hz)	VBW(Hz)	Detector	Freq(Hz)	Level(dBm)	Limit(dBm)	Margin(dB)	Remark	Ref.Limit(dB)
3.45G	3.53G	200k	1M	RMS	3.4785G	-52.74	-40.00	-12.74	MBW 1M	-
3.53G	3.6025G	200k	1M	RMS	3.602G	-47.00	-25.00	-22.00	MBW 1M	-
3.6025G	3.6165G	200k	1M	RMS	3.616G	-29.05	-13.00	-16.05	MBW 1M	-
3.6165G	3.6175G	200k	1M	RMS	3.61748G	-33.02	-13.00	-20.02	-	-
3.6325G	3.6335G	200k	1M	RMS	3.63255G	-32.46	-13.00	-19.46	-	-
3.6335G	3.6475G	200k	1M	RMS	3.634G	-29.58	-13.00	-16.58	MBW 1M	-
3.6475G	3.72G	200k	1M	RMS	3.648G	-46.90	-25.00	-21.90	MBW 1M	-
3.72G	3.8G	200k	1M	RMS	3.7895G	-52.82	-40.00	-12.82	MBW 1M	-

Band 48\_LTE\_15MHz\_Nss1,64QAM\_1TX  
3625MHz\_64QAM\_RB 1,#RB L

CSE-TX-Sum

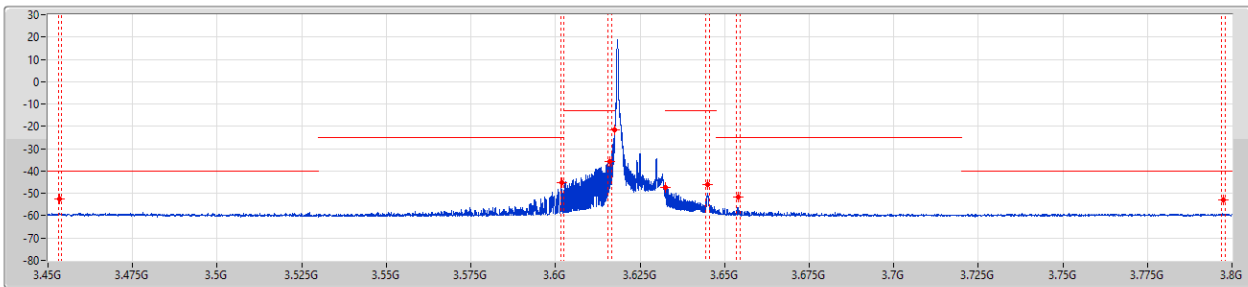

Limit

Port 1

F-Start(Hz)	F-Stop(Hz)	RBW(Hz)	VBW(Hz)	Detector	Freq(Hz)	Level(dBm)	Limit(dBm)	Margin(dB)	Remark	Ref.Limit(dB)
3.45G	3.53G	200k	1M	RMS	3.4535G	-52.60	-40.00	-12.60	MBW 1M	-
3.53G	3.6025G	200k	1M	RMS	3.602G	-45.18	-25.00	-20.18	MBW 1M	-
3.6025G	3.6165G	200k	1M	RMS	3.616G	-35.68	-13.00	-22.68	MBW 1M	-
3.6165G	3.6175G	200k	1M	RMS	3.61742G	-21.70	-13.00	-8.70	-	-
3.6325G	3.6335G	200k	1M	RMS	3.63262G	-47.41	-13.00	-34.41	-	-
3.6335G	3.6475G	200k	1M	RMS	3.645G	-46.05	-13.00	-33.05	MBW 1M	-
3.6475G	3.72G	200k	1M	RMS	3.654G	-51.69	-25.00	-26.69	MBW 1M	-
3.72G	3.8G	200k	1M	RMS	3.7975G	-52.82	-40.00	-12.82	MBW 1M	-



Band 48\_LTE\_15MHz\_Nss1,64QAM\_1TX  
3692.5MHz\_64QAM\_RB 75,#RB 0

CSE-TX-Sum

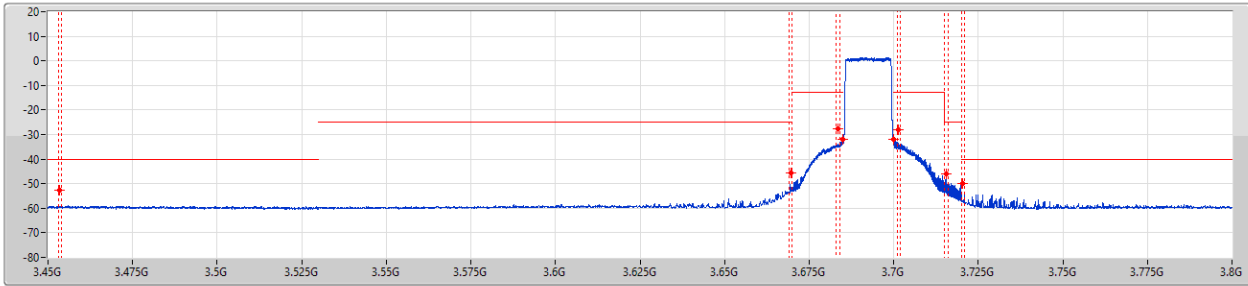

F-Start(Hz)	F-Stop(Hz)	RBW(Hz)	VBW(Hz)	Detector	Freq(Hz)	Level(dBm)	Limit(dBm)	Margin(dB)	Remark	Ref.Limit(dB)
3.45G	3.53G	200k	1M	RMS	3.4535G	-52.75	-40.00	-12.75	MBW 1M	-
3.53G	3.67G	200k	1M	RMS	3.6695G	-45.80	-25.00	-20.80	MBW 1M	-
3.67G	3.684G	200k	1M	RMS	3.6835G	-27.80	-13.00	-14.80	MBW 1M	-
3.684G	3.685G	200k	1M	RMS	3.68496G	-31.94	-13.00	-18.94	-	-
3.7G	3.701G	200k	1M	RMS	3.70008G	-32.13	-13.00	-19.13	-	-
3.701G	3.71G	200k	1M	RMS	3.7015G	-28.21	-13.00	-15.21	MBW 1M	-
3.71G	3.72G	200k	1M	RMS	3.7155G	-45.91	-25.00	-20.91	MBW 1M	-
3.72G	3.8G	200k	1M	RMS	3.7205G	-49.95	-40.00	-9.95	MBW 1M	-

Band 48\_LTE\_15MHz\_Nss1,64QAM\_1TX  
3692.5MHz\_64QAM\_RB 1,#RB R

CSE-TX-Sum

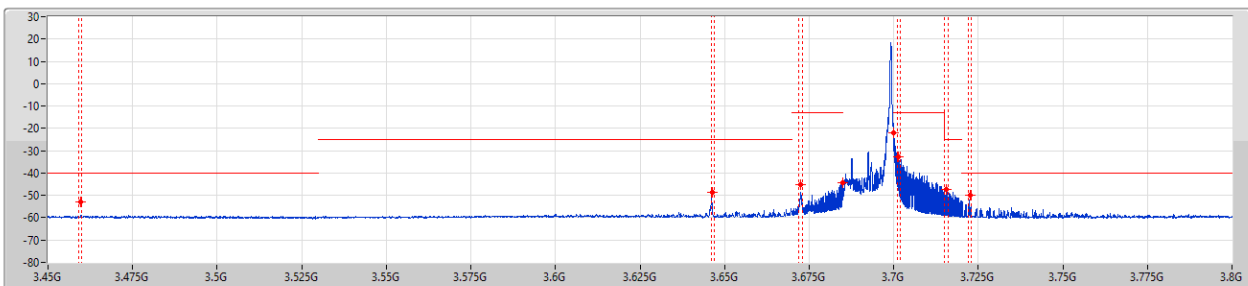

F-Start(Hz)	F-Stop(Hz)	RBW(Hz)	VBW(Hz)	Detector	Freq(Hz)	Level(dBm)	Limit(dBm)	Margin(dB)	Remark	Ref.Limit(dB)
3.45G	3.53G	200k	1M	RMS	3.4595G	-52.77	-40.00	-12.77	MBW 1M	-
3.53G	3.67G	200k	1M	RMS	3.6465G	-48.43	-25.00	-23.43	MBW 1M	-
3.67G	3.684G	200k	1M	RMS	3.6725G	-45.14	-13.00	-32.14	MBW 1M	-
3.684G	3.685G	200k	1M	RMS	3.68495G	-44.13	-13.00	-31.13	-	-
3.7G	3.701G	200k	1M	RMS	3.70001G	-22.14	-13.00	-9.14	-	-
3.701G	3.71G	200k	1M	RMS	3.7015G	-32.84	-13.00	-19.84	MBW 1M	-
3.71G	3.72G	200k	1M	RMS	3.7155G	-47.18	-25.00	-22.18	MBW 1M	-
3.72G	3.8G	200k	1M	RMS	3.7225G	-49.98	-40.00	-9.98	MBW 1M	-



Band 48\_LTE\_15MHz\_Nss1,256QAM\_1TX  
3557.5MHz\_256QAM\_RB 75,#RB 0

CSE-TX-Sum

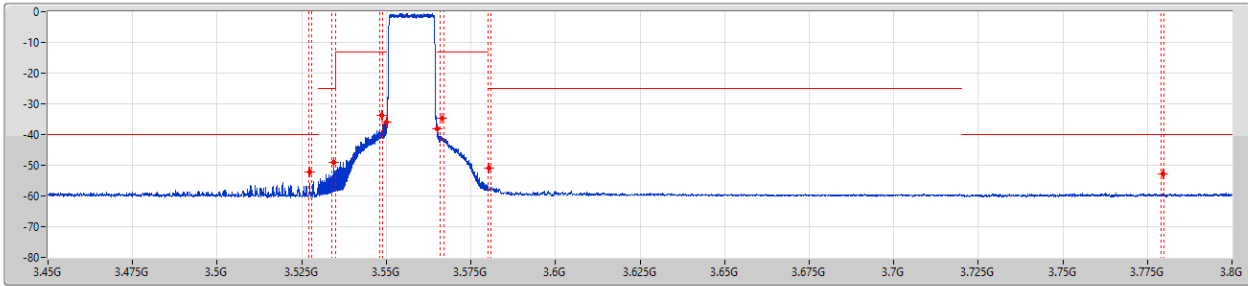

F.Start(Hz)	F.Stop(Hz)	RBW(Hz)	VBW(Hz)	Detector	Freq(Hz)	Level(dBm)	Limit(dBm)	Margin(dB)	Remark	Ref.Limit(dB)
3.45G	3.53G	200k	1M	RMS	3.5275G	-52.10	-40.00	-12.10	MBW 1M	-
3.53G	3.54G	200k	1M	RMS	3.5345G	-49.20	-25.00	-24.20	MBW 1M	-
3.54G	3.549G	200k	1M	RMS	3.5485G	-33.69	-13.00	-20.69	MBW 1M	-
3.549G	3.55G	200k	1M	RMS	3.54991G	-35.79	-13.00	-22.79	-	-
3.565G	3.566G	200k	1M	RMS	3.56501G	-38.17	-13.00	-25.17	-	-
3.566G	3.58G	200k	1M	RMS	3.5665G	-34.81	-13.00	-21.81	MBW 1M	-
3.58G	3.72G	200k	1M	RMS	3.5805G	-51.04	-25.00	-26.04	MBW 1M	-
3.72G	3.8G	200k	1M	RMS	3.7795G	-52.82	-40.00	-12.82	MBW 1M	-

Band 48\_LTE\_15MHz\_Nss1,256QAM\_1TX  
3557.5MHz\_256QAM\_RB 1,#RB L

CSE-TX-Sum

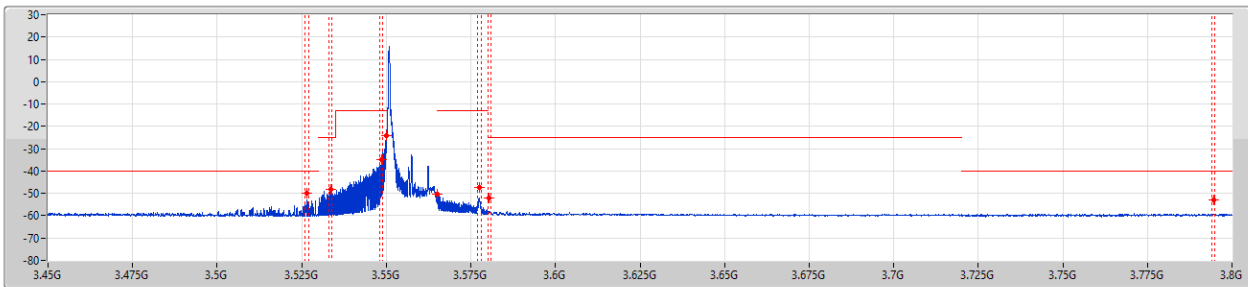

F.Start(Hz)	F.Stop(Hz)	RBW(Hz)	VBW(Hz)	Detector	Freq(Hz)	Level(dBm)	Limit(dBm)	Margin(dB)	Remark	Ref.Limit(dB)
3.45G	3.53G	200k	1M	RMS	3.5265G	-49.84	-40.00	-9.84	MBW 1M	-
3.53G	3.54G	200k	1M	RMS	3.5335G	-48.09	-25.00	-23.09	MBW 1M	-
3.54G	3.549G	200k	1M	RMS	3.5485G	-34.81	-13.00	-21.81	MBW 1M	-
3.549G	3.55G	200k	1M	RMS	3.54999G	-23.94	-13.00	-10.94	-	-
3.565G	3.566G	200k	1M	RMS	3.56514G	-50.25	-13.00	-37.25	-	-
3.566G	3.58G	200k	1M	RMS	3.5775G	-47.49	-13.00	-34.49	MBW 1M	-
3.58G	3.72G	200k	1M	RMS	3.5805G	-51.86	-25.00	-26.86	MBW 1M	-
3.72G	3.8G	200k	1M	RMS	3.7945G	-52.83	-40.00	-12.83	MBW 1M	-



Band 48\_LTE\_15MHz\_Nss1,256QAM\_1TX  
3625MHz\_256QAM\_RB 75,#RB 0

CSE-TX-Sum

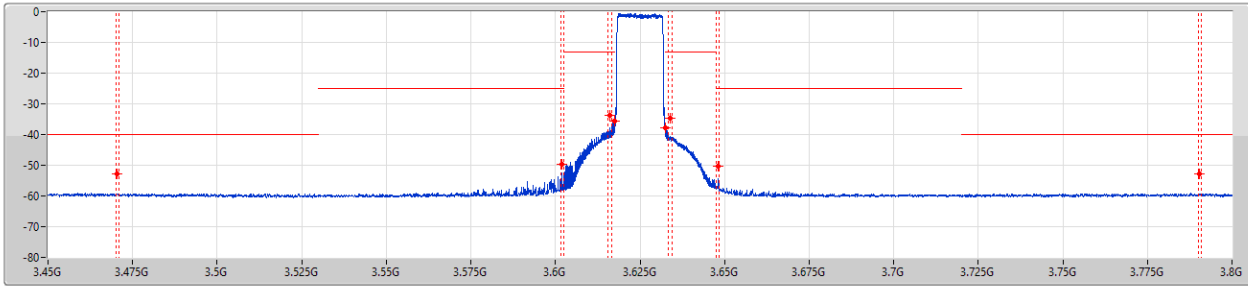

F-Start(Hz)	F-Stop(Hz)	RBW(Hz)	VBW(Hz)	Detector	Freq(Hz)	Level(dBm)	Limit(dBm)	Margin(dB)	Remark	Ref.Limit(dB)
3.45G	3.53G	200k	1M	RMS	3.4705G	-52.79	-40.00	-12.79	MBW 1M	-
3.53G	3.6025G	200k	1M	RMS	3.602G	-49.74	-25.00	-24.74	MBW 1M	-
3.6025G	3.6165G	200k	1M	RMS	3.616G	-33.65	-13.00	-20.65	MBW 1M	-
3.6165G	3.6175G	200k	1M	RMS	3.61749G	-35.54	-13.00	-22.54	-	-
3.6325G	3.6335G	200k	1M	RMS	3.63251G	-37.78	-13.00	-24.78	-	-
3.6335G	3.6475G	200k	1M	RMS	3.634G	-34.63	-13.00	-21.63	MBW 1M	-
3.6475G	3.72G	200k	1M	RMS	3.648G	-50.18	-25.00	-25.18	MBW 1M	-
3.72G	3.8G	200k	1M	RMS	3.7905G	-52.84	-40.00	-12.84	MBW 1M	-

Band 48\_LTE\_15MHz\_Nss1,256QAM\_1TX  
3625MHz\_256QAM\_RB 1,#RB L

CSE-TX-Sum

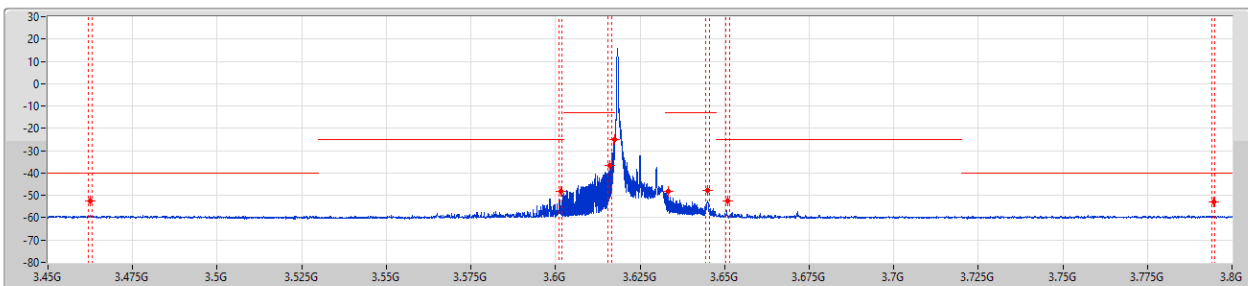

F-Start(Hz)	F-Stop(Hz)	RBW(Hz)	VBW(Hz)	Detector	Freq(Hz)	Level(dBm)	Limit(dBm)	Margin(dB)	Remark	Ref.Limit(dB)
3.45G	3.53G	200k	1M	RMS	3.4625G	-52.65	-40.00	-12.65	MBW 1M	-
3.53G	3.6025G	200k	1M	RMS	3.6015G	-48.08	-25.00	-23.08	MBW 1M	-
3.6025G	3.6165G	200k	1M	RMS	3.616G	-36.46	-13.00	-23.46	MBW 1M	-
3.6165G	3.6175G	200k	1M	RMS	3.61748G	-25.10	-13.00	-12.10	-	-
3.6325G	3.6335G	200k	1M	RMS	3.63349G	-48.00	-13.00	-35.00	-	-
3.6335G	3.6475G	200k	1M	RMS	3.645G	-47.71	-13.00	-34.71	MBW 1M	-
3.6475G	3.72G	200k	1M	RMS	3.651G	-52.37	-25.00	-27.37	MBW 1M	-
3.72G	3.8G	200k	1M	RMS	3.7945G	-52.82	-40.00	-12.82	MBW 1M	-



Band 48\_LTE\_15MHz\_Nss1,256QAM\_1TX  
3692.5MHz\_256QAM\_RB 75,#RB 0

CSE-TX-Sum

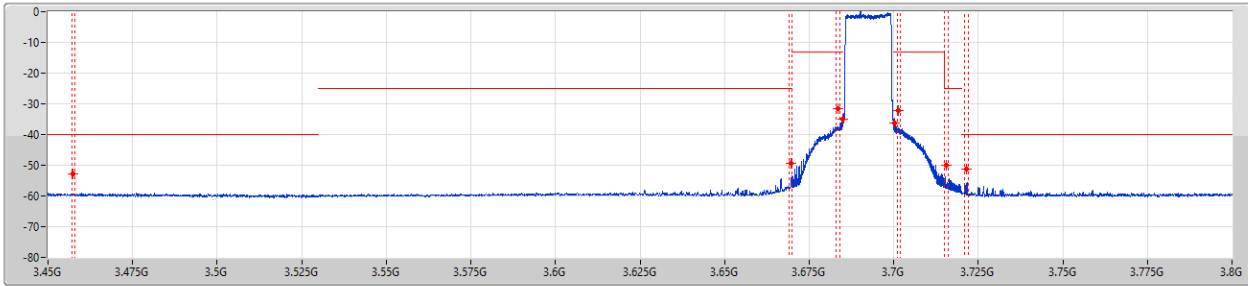

F-Start(Hz)	F-Stop(Hz)	RBW(Hz)	VBW(Hz)	Detector	Freq(Hz)	Level(dBm)	Limit(dBm)	Margin(dB)	Remark	Ref.Limit(dB)
3.45G	3.53G	200k	1M	RMS	3.4575G	-52.78	-40.00	-12.78	MBW 1M	-
3.53G	3.67G	200k	1M	RMS	3.6695G	-49.37	-25.00	-24.37	MBW 1M	-
3.67G	3.684G	200k	1M	RMS	3.6835G	-31.45	-13.00	-18.45	MBW 1M	-
3.684G	3.685G	200k	1M	RMS	3.68493G	-35.09	-13.00	-22.09	-	-
3.7G	3.701G	200k	1M	RMS	3.70024G	-36.31	-13.00	-23.31	-	-
3.701G	3.71G	200k	1M	RMS	3.7015G	-32.14	-13.00	-19.14	MBW 1M	-
3.71G	3.72G	200k	1M	RMS	3.7155G	-49.90	-25.00	-24.90	MBW 1M	-
3.72G	3.8G	200k	1M	RMS	3.7215G	-51.25	-40.00	-11.25	MBW 1M	-

Band 48\_LTE\_15MHz\_Nss1,256QAM\_1TX  
3692.5MHz\_256QAM\_RB 1,#RB R

CSE-TX-Sum

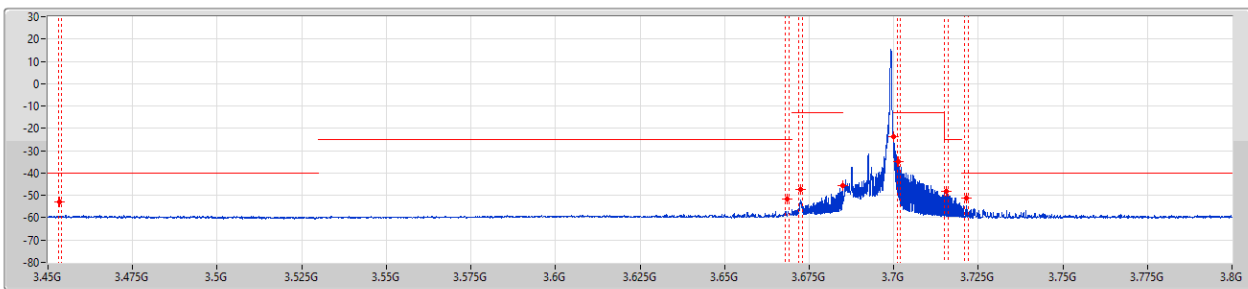

F-Start(Hz)	F-Stop(Hz)	RBW(Hz)	VBW(Hz)	Detector	Freq(Hz)	Level(dBm)	Limit(dBm)	Margin(dB)	Remark	Ref.Limit(dB)
3.45G	3.53G	200k	1M	RMS	3.4535G	-52.80	-40.00	-12.80	MBW 1M	-
3.53G	3.67G	200k	1M	RMS	3.6685G	-51.51	-25.00	-26.51	MBW 1M	-
3.67G	3.684G	200k	1M	RMS	3.6725G	-47.46	-13.00	-34.46	MBW 1M	-
3.684G	3.685G	200k	1M	RMS	3.6849G	-45.80	-13.00	-32.80	-	-
3.7G	3.701G	200k	1M	RMS	3.70001G	-23.85	-13.00	-10.85	-	-
3.701G	3.71G	200k	1M	RMS	3.7015G	-34.78	-13.00	-21.78	MBW 1M	-
3.71G	3.72G	200k	1M	RMS	3.7155G	-48.33	-25.00	-23.33	MBW 1M	-
3.72G	3.8G	200k	1M	RMS	3.7215G	-51.32	-40.00	-11.32	MBW 1M	-



Band 48\_LTE\_10MHz\_Nss1,QPSK\_1TX  
3555MHz\_QPSK\_RB 50,#RB 0

CSE-TX-Sum

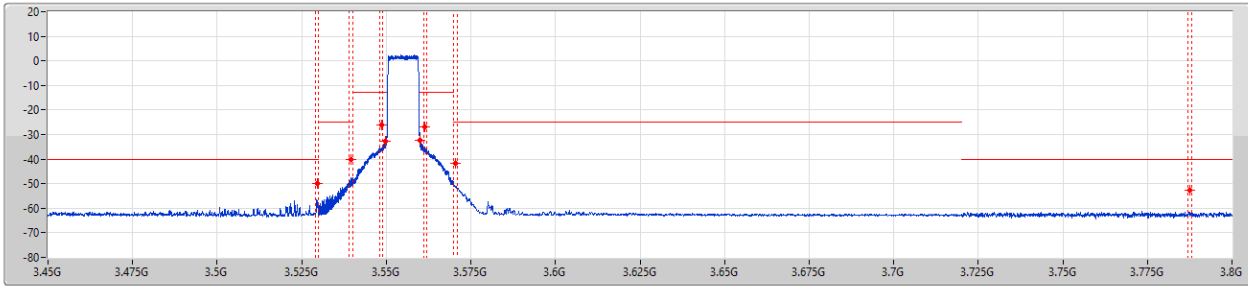

F-Start(Hz)	F-Stop(Hz)	RBW(Hz)	VBW(Hz)	Detector	Freq(Hz)	Level(dBm)	Limit(dBm)	Margin(dB)	Remark	Ref.Limit(dB)
3.45G	3.53G	100k	300k	RMS	3.5295G	-49.75	-40.00	-9.75	MBW 1M	-
3.53G	3.54G	100k	300k	RMS	3.5395G	-40.11	-25.00	-15.11	MBW 1M	-
3.54G	3.549G	100k	300k	RMS	3.5485G	-26.21	-13.00	-13.21	MBW 1M	-
3.549G	3.55G	100k	300k	RMS	3.54981G	-32.58	-13.00	-19.58	-	-
3.56G	3.561G	100k	300k	RMS	3.56004G	-32.33	-13.00	-19.33	-	-
3.561G	3.57G	100k	300k	RMS	3.5615G	-26.79	-13.00	-13.79	MBW 1M	-
3.57G	3.72G	100k	300k	RMS	3.5705G	-41.54	-25.00	-16.54	MBW 1M	-
3.72G	3.8G	100k	300k	RMS	3.7875G	-52.52	-40.00	-12.52	MBW 1M	-

Band 48\_LTE\_10MHz\_Nss1,QPSK\_1TX  
3555MHz\_QPSK\_RB 1,#RB L

CSE-TX-Sum

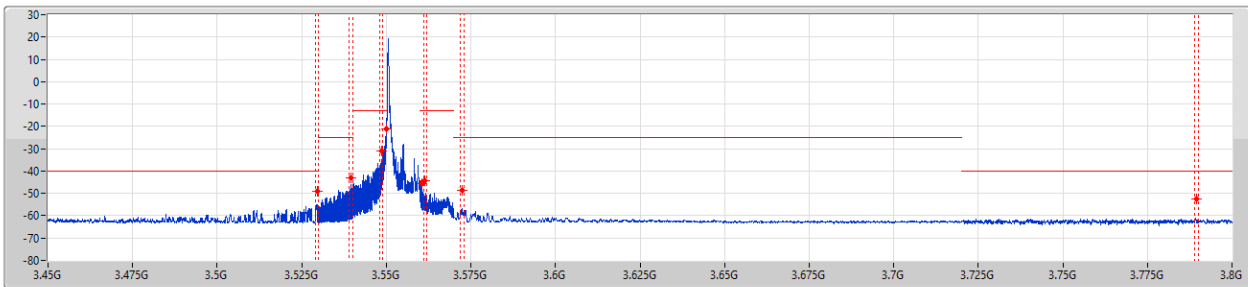

F-Start(Hz)	F-Stop(Hz)	RBW(Hz)	VBW(Hz)	Detector	Freq(Hz)	Level(dBm)	Limit(dBm)	Margin(dB)	Remark	Ref.Limit(dB)
3.45G	3.53G	100k	300k	RMS	3.5295G	-48.92	-40.00	-8.92	MBW 1M	-
3.53G	3.54G	100k	300k	RMS	3.5395G	-43.09	-25.00	-18.09	MBW 1M	-
3.54G	3.549G	100k	300k	RMS	3.5485G	-31.22	-13.00	-18.22	MBW 1M	-
3.549G	3.55G	100k	300k	RMS	3.54999G	-21.25	-13.00	-8.25	-	-
3.56G	3.561G	100k	300k	RMS	3.5604G	-45.51	-13.00	-32.51	-	-
3.561G	3.57G	100k	300k	RMS	3.5615G	-44.36	-13.00	-31.36	MBW 1M	-
3.57G	3.72G	100k	300k	RMS	3.5725G	-48.78	-25.00	-23.78	MBW 1M	-
3.72G	3.8G	100k	300k	RMS	3.7895G	-52.49	-40.00	-12.49	MBW 1M	-



Band 48\_LTE\_10MHz\_Nss1,QPSK\_1TX  
3625MHz\_QPSK\_RB 50,#RB 0

CSE-TX-Sum

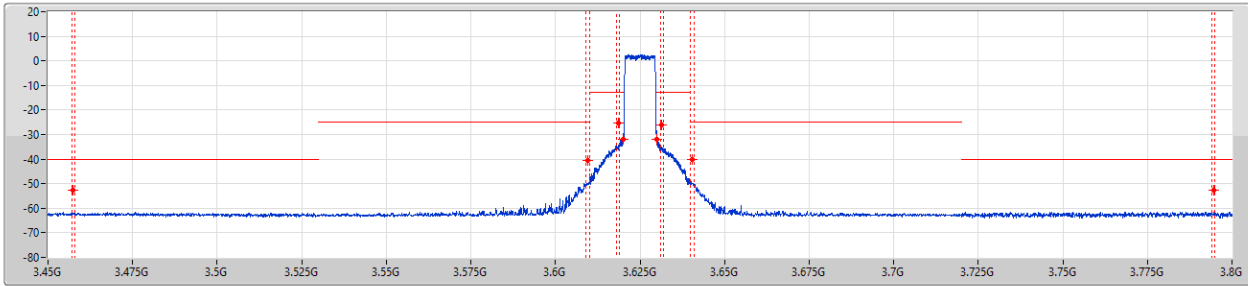

F-Start(Hz)	F-Stop(Hz)	RBW(Hz)	VBW(Hz)	Detector	Freq(Hz)	Level(dBm)	Limit(dBm)	Margin(dB)	Remark	Ref.Limit(dB)
3.45G	3.53G	100k	300k	RMS	3.4575G	-52.58	-40.00	-12.58	MBW 1M	-
3.53G	3.61G	100k	300k	RMS	3.6095G	-40.38	-25.00	-15.38	MBW 1M	-
3.61G	3.619G	100k	300k	RMS	3.6185G	-25.15	-13.00	-12.15	MBW 1M	-
3.619G	3.62G	100k	300k	RMS	3.61999G	-31.83	-13.00	-18.83	-	-
3.63G	3.631G	100k	300k	RMS	3.63005G	-32.01	-13.00	-19.01	-	-
3.631G	3.64G	100k	300k	RMS	3.6315G	-26.14	-13.00	-13.14	MBW 1M	-
3.64G	3.72G	100k	300k	RMS	3.6405G	-40.30	-25.00	-15.30	MBW 1M	-
3.72G	3.8G	100k	300k	RMS	3.7945G	-52.61	-40.00	-12.61	MBW 1M	-

Band 48\_LTE\_10MHz\_Nss1,QPSK\_1TX  
3625MHz\_QPSK\_RB 1,#RB L

CSE-TX-Sum

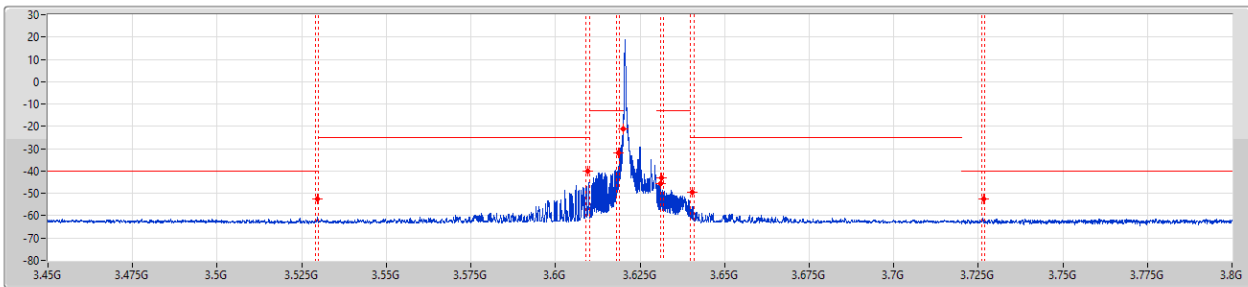

F-Start(Hz)	F-Stop(Hz)	RBW(Hz)	VBW(Hz)	Detector	Freq(Hz)	Level(dBm)	Limit(dBm)	Margin(dB)	Remark	Ref.Limit(dB)
3.45G	3.53G	100k	300k	RMS	3.5295G	-52.37	-40.00	-12.37	MBW 1M	-
3.53G	3.61G	100k	300k	RMS	3.6095G	-39.98	-25.00	-14.98	MBW 1M	-
3.61G	3.619G	100k	300k	RMS	3.6185G	-32.08	-13.00	-19.08	MBW 1M	-
3.619G	3.62G	100k	300k	RMS	3.62G	-20.96	-13.00	-7.96	-	-
3.63G	3.631G	100k	300k	RMS	3.63096G	-45.64	-13.00	-32.64	-	-
3.631G	3.64G	100k	300k	RMS	3.6315G	-43.05	-13.00	-30.05	MBW 1M	-
3.64G	3.72G	100k	300k	RMS	3.6405G	-49.62	-25.00	-24.62	MBW 1M	-
3.72G	3.8G	100k	300k	RMS	3.7265G	-52.48	-40.00	-12.48	MBW 1M	-





Band 48\_LTE\_10MHz\_Nss1,QPSK\_1TX  
3695MHz\_QPSK\_RB 50,#RB 0

CSE-TX-Sum

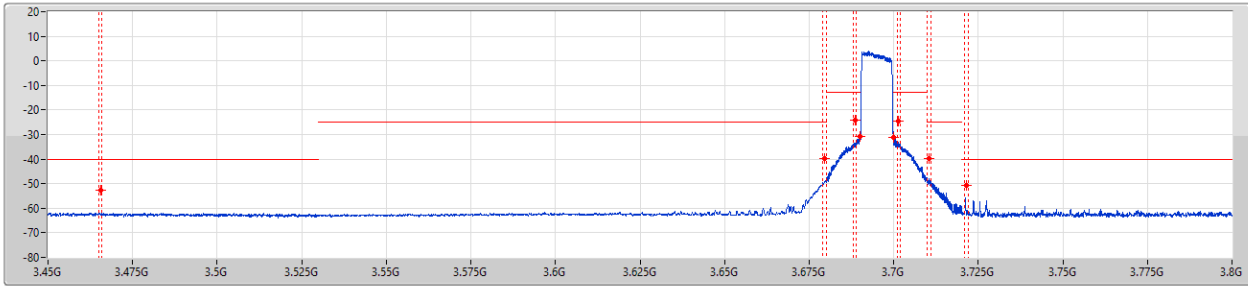

F-Start(Hz)	F-Stop(Hz)	RBW(Hz)	VBW(Hz)	Detector	Freq(Hz)	Level(dBm)	Limit(dBm)	Margin(dB)	Remark	Ref.Limit(dB)
3.45G	3.53G	100k	300k	RMS	3.4655G	-52.59	-40.00	-12.59	MBW 1M	-
3.53G	3.68G	100k	300k	RMS	3.6795G	-39.69	-25.00	-14.69	MBW 1M	-
3.68G	3.689G	100k	300k	RMS	3.6885G	-24.29	-13.00	-11.29	MBW 1M	-
3.689G	3.69G	100k	300k	RMS	3.68997G	-30.80	-13.00	-17.80	-	-
3.7G	3.701G	100k	300k	RMS	3.70005G	-31.10	-13.00	-18.10	-	-
3.701G	3.71G	100k	300k	RMS	3.7015G	-24.62	-13.00	-11.62	MBW 1M	-
3.71G	3.72G	100k	300k	RMS	3.7105G	-39.70	-25.00	-14.70	MBW 1M	-
3.72G	3.8G	100k	300k	RMS	3.7215G	-50.51	-40.00	-10.51	MBW 1M	-

Band 48\_LTE\_10MHz\_Nss1,QPSK\_1TX  
3695MHz\_QPSK\_RB 1,#RB R

CSE-TX-Sum

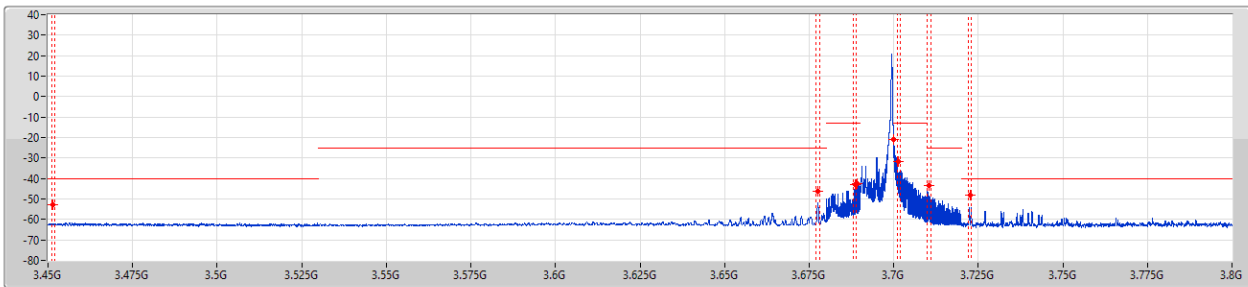

F-Start(Hz)	F-Stop(Hz)	RBW(Hz)	VBW(Hz)	Detector	Freq(Hz)	Level(dBm)	Limit(dBm)	Margin(dB)	Remark	Ref.Limit(dB)
3.45G	3.53G	100k	300k	RMS	3.4515G	-52.58	-40.00	-12.58	MBW 1M	-
3.53G	3.68G	100k	300k	RMS	3.6775G	-46.06	-25.00	-21.06	MBW 1M	-
3.68G	3.689G	100k	300k	RMS	3.6885G	-42.75	-13.00	-29.75	MBW 1M	-
3.689G	3.69G	100k	300k	RMS	3.68913G	-42.58	-13.00	-29.58	-	-
3.7G	3.701G	100k	300k	RMS	3.7G	-20.74	-13.00	-7.74	-	-
3.701G	3.71G	100k	300k	RMS	3.7015G	-31.68	-13.00	-18.68	MBW 1M	-
3.71G	3.72G	100k	300k	RMS	3.7105G	-43.45	-25.00	-18.45	MBW 1M	-
3.72G	3.8G	100k	300k	RMS	3.7225G	-48.04	-40.00	-8.04	MBW 1M	-



Band 48\_LTE\_10MHz\_Nss1,16QAM\_1TX  
3555MHz\_16QAM\_RB 50,#RB 0

CSE-TX-Sum

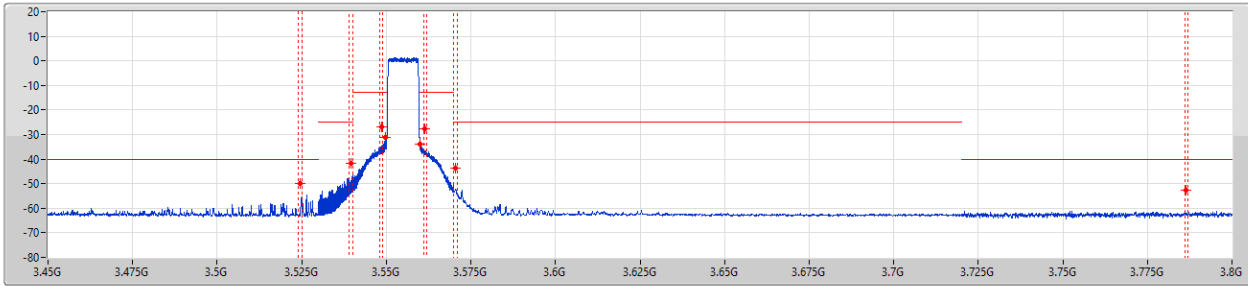

F-Start(Hz)	F-Stop(Hz)	RBW(Hz)	VBW(Hz)	Detector	Freq(Hz)	Level(dBm)	Limit(dBm)	Margin(dB)	Remark	Ref.Limit(dB)
3.45G	3.53G	100k	300k	RMS	3.5245G	-49.86	-40.00	-9.86	MBW 1M	-
3.53G	3.54G	100k	300k	RMS	3.5395G	-41.89	-25.00	-16.89	MBW 1M	-
3.54G	3.549G	100k	300k	RMS	3.5485G	-26.75	-13.00	-13.75	MBW 1M	-
3.549G	3.55G	100k	300k	RMS	3.54976G	-31.18	-13.00	-18.18	-	-
3.56G	3.561G	100k	300k	RMS	3.56003G	-33.98	-13.00	-20.98	-	-
3.561G	3.57G	100k	300k	RMS	3.5615G	-27.59	-13.00	-14.59	MBW 1M	-
3.57G	3.72G	100k	300k	RMS	3.5705G	-43.59	-25.00	-18.59	MBW 1M	-
3.72G	3.8G	100k	300k	RMS	3.7865G	-52.61	-40.00	-12.61	MBW 1M	-

Band 48\_LTE\_10MHz\_Nss1,16QAM\_1TX  
3555MHz\_16QAM\_RB 1,#RB L

CSE-TX-Sum

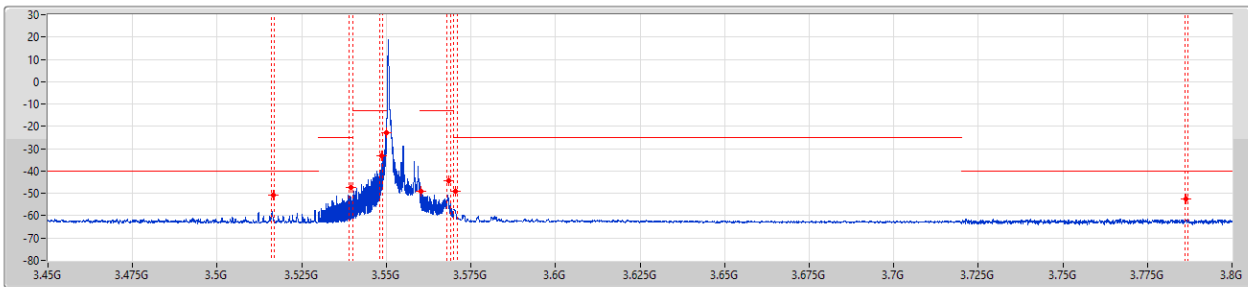

F-Start(Hz)	F-Stop(Hz)	RBW(Hz)	VBW(Hz)	Detector	Freq(Hz)	Level(dBm)	Limit(dBm)	Margin(dB)	Remark	Ref.Limit(dB)
3.45G	3.53G	100k	300k	RMS	3.5165G	-50.92	-40.00	-10.92	MBW 1M	-
3.53G	3.54G	100k	300k	RMS	3.5395G	-47.22	-25.00	-22.22	MBW 1M	-
3.54G	3.549G	100k	300k	RMS	3.5485G	-33.30	-13.00	-20.30	MBW 1M	-
3.549G	3.55G	100k	300k	RMS	3.54999G	-22.65	-13.00	-9.65	-	-
3.56G	3.561G	100k	300k	RMS	3.5603G	-49.13	-13.00	-36.13	-	-
3.561G	3.57G	100k	300k	RMS	3.5685G	-44.50	-13.00	-31.50	MBW 1M	-
3.57G	3.72G	100k	300k	RMS	3.5705G	-49.10	-25.00	-24.10	MBW 1M	-
3.72G	3.8G	100k	300k	RMS	3.7865G	-52.59	-40.00	-12.59	MBW 1M	-



Band 48\_LTE\_10MHz\_Nss1,16QAM\_1TX  
3625MHz\_16QAM\_RB 50,#RB 0

CSE-TX-Sum

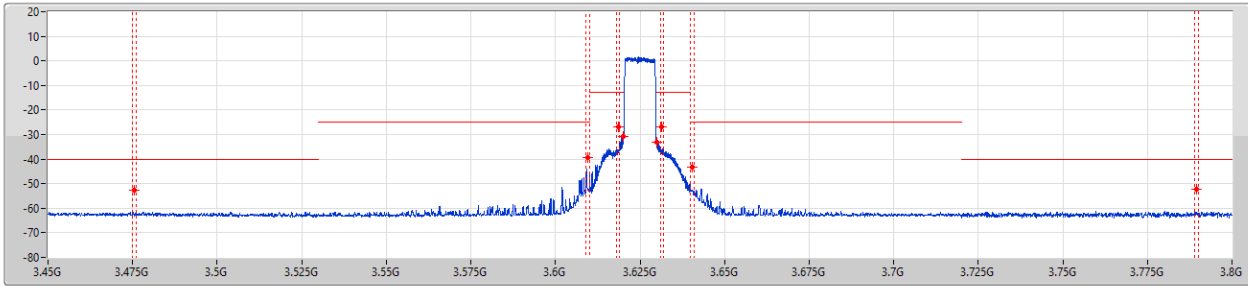

F-Start(Hz)	F-Stop(Hz)	RBW(Hz)	VBW(Hz)	Detector	Freq(Hz)	Level(dBm)	Limit(dBm)	Margin(dB)	Remark	Ref.Limit(dB)
3.45G	3.53G	100k	300k	RMS	3.4755G	-52.53	-40.00	-12.53	MBW 1M	-
3.53G	3.61G	100k	300k	RMS	3.6095G	-39.40	-25.00	-14.40	MBW 1M	-
3.61G	3.619G	100k	300k	RMS	3.6185G	-27.00	-13.00	-14.00	MBW 1M	-
3.619G	3.62G	100k	300k	RMS	3.61998G	-30.65	-13.00	-17.65	-	-
3.63G	3.631G	100k	300k	RMS	3.63006G	-33.30	-13.00	-20.30	-	-
3.631G	3.64G	100k	300k	RMS	3.6315G	-27.03	-13.00	-14.03	MBW 1M	-
3.64G	3.72G	100k	300k	RMS	3.6405G	-43.41	-25.00	-18.41	MBW 1M	-
3.72G	3.8G	100k	300k	RMS	3.7895G	-52.41	-40.00	-12.41	MBW 1M	-

Band 48\_LTE\_10MHz\_Nss1,16QAM\_1TX  
3625MHz\_16QAM\_RB 1,#RB L

CSE-TX-Sum

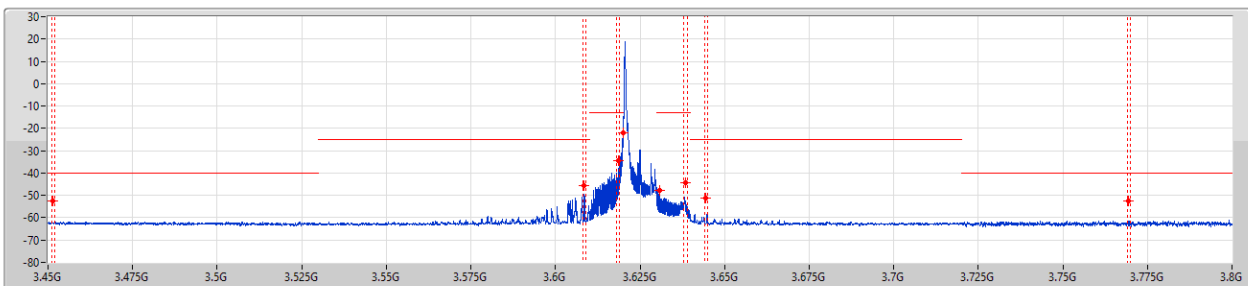

F-Start(Hz)	F-Stop(Hz)	RBW(Hz)	VBW(Hz)	Detector	Freq(Hz)	Level(dBm)	Limit(dBm)	Margin(dB)	Remark	Ref.Limit(dB)
3.45G	3.53G	100k	300k	RMS	3.4515G	-52.61	-40.00	-12.61	MBW 1M	-
3.53G	3.61G	100k	300k	RMS	3.6085G	-45.83	-25.00	-20.83	MBW 1M	-
3.61G	3.619G	100k	300k	RMS	3.6185G	-34.57	-13.00	-21.57	MBW 1M	-
3.619G	3.62G	100k	300k	RMS	3.61998G	-21.89	-13.00	-8.89	-	-
3.63G	3.631G	100k	300k	RMS	3.63078G	-47.75	-13.00	-34.75	-	-
3.631G	3.64G	100k	300k	RMS	3.6385G	-44.49	-13.00	-31.49	MBW 1M	-
3.64G	3.72G	100k	300k	RMS	3.6445G	-51.29	-25.00	-26.29	MBW 1M	-
3.72G	3.8G	100k	300k	RMS	3.7695G	-52.55	-40.00	-12.55	MBW 1M	-



Band 48\_LTE\_10MHz\_Nss1,16QAM\_1TX  
3695MHz\_16QAM\_RB 50,#RB 0

CSE-TX-Sum

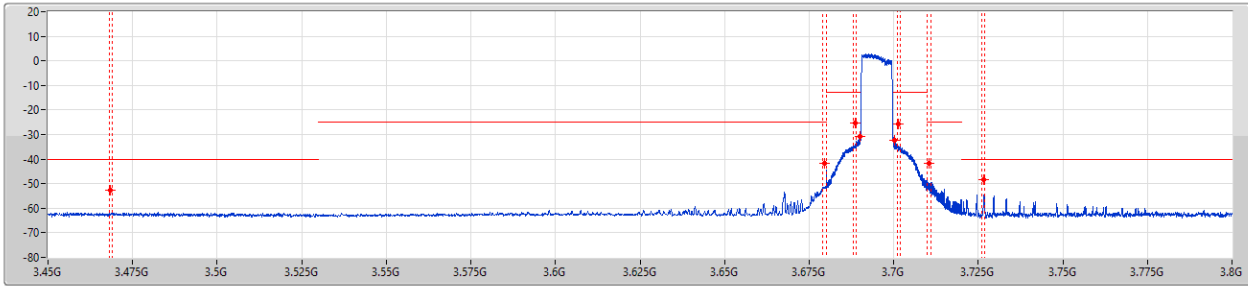

F-Start(Hz)	F-Stop(Hz)	RBW(Hz)	VBW(Hz)	Detector	Freq(Hz)	Level(dBm)	Limit(dBm)	Margin(dB)	Remark	Ref.Limit(dB)
3.45G	3.53G	100k	300k	RMS	3.4685G	-52.57	-40.00	-12.57	MBW 1M	-
3.53G	3.68G	100k	300k	RMS	3.6795G	-41.82	-25.00	-16.82	MBW 1M	-
3.68G	3.689G	100k	300k	RMS	3.6885G	-25.21	-13.00	-12.21	MBW 1M	-
3.689G	3.69G	100k	300k	RMS	3.68997G	-30.94	-13.00	-17.94	-	-
3.7G	3.701G	100k	300k	RMS	3.70015G	-32.39	-13.00	-19.39	-	-
3.701G	3.71G	100k	300k	RMS	3.7015G	-25.76	-13.00	-12.76	MBW 1M	-
3.71G	3.72G	100k	300k	RMS	3.7105G	-41.90	-25.00	-16.90	MBW 1M	-
3.72G	3.8G	100k	300k	RMS	3.7265G	-48.52	-40.00	-8.52	MBW 1M	-

Band 48\_LTE\_10MHz\_Nss1,16QAM\_1TX  
3695MHz\_16QAM\_RB 1,#RB R

CSE-TX-Sum

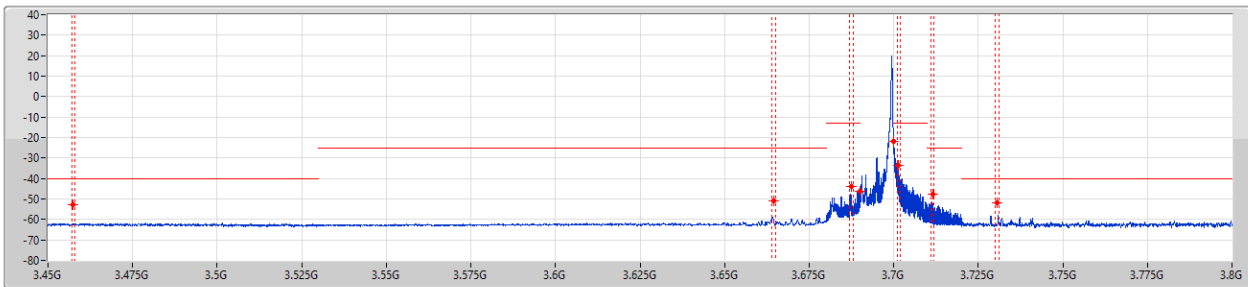

F-Start(Hz)	F-Stop(Hz)	RBW(Hz)	VBW(Hz)	Detector	Freq(Hz)	Level(dBm)	Limit(dBm)	Margin(dB)	Remark	Ref.Limit(dB)
3.45G	3.53G	100k	300k	RMS	3.4575G	-52.67	-40.00	-12.67	MBW 1M	-
3.53G	3.68G	100k	300k	RMS	3.6645G	-50.84	-25.00	-25.84	MBW 1M	-
3.68G	3.689G	100k	300k	RMS	3.6875G	-44.05	-13.00	-31.05	MBW 1M	-
3.689G	3.69G	100k	300k	RMS	3.68998G	-46.40	-13.00	-33.40	-	-
3.7G	3.701G	100k	300k	RMS	3.70006G	-21.93	-13.00	-8.93	-	-
3.701G	3.71G	100k	300k	RMS	3.7015G	-33.63	-13.00	-20.63	MBW 1M	-
3.71G	3.72G	100k	300k	RMS	3.7115G	-47.63	-25.00	-22.63	MBW 1M	-
3.72G	3.8G	100k	300k	RMS	3.7305G	-51.68	-40.00	-11.68	MBW 1M	-



Band 48\_LTE\_10MHz\_Nss1,64QAM\_1TX  
3555MHz\_64QAM\_RB 50,#RB 0

CSE-TX-Sum

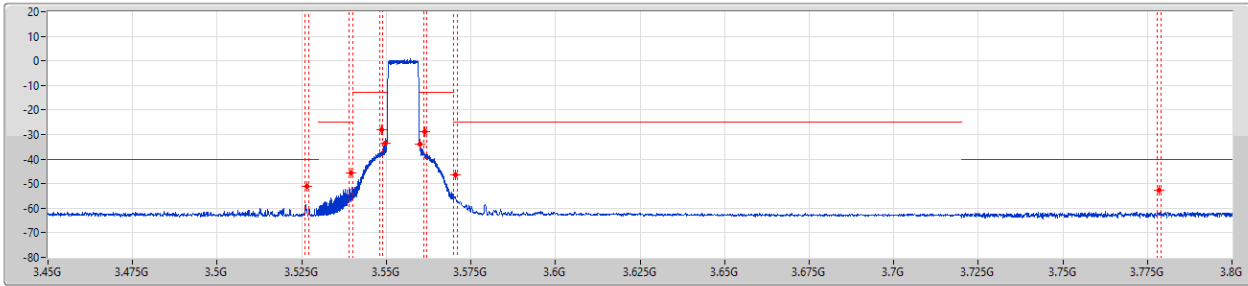

F.Start(Hz)	F.Stop(Hz)	RBW(Hz)	VBW(Hz)	Detector	Freq(Hz)	Level(dBm)	Limit(dBm)	Margin(dB)	Remark	Ref.Limit(dB)
3.45G	3.53G	100k	300k	RMS	3.5265G	-51.24	-40.00	-11.24	MBW 1M	-
3.53G	3.54G	100k	300k	RMS	3.5395G	-45.62	-25.00	-20.62	MBW 1M	-
3.54G	3.549G	100k	300k	RMS	3.5485G	-28.16	-13.00	-15.16	MBW 1M	-
3.549G	3.55G	100k	300k	RMS	3.54978G	-33.37	-13.00	-20.37	-	-
3.56G	3.561G	100k	300k	RMS	3.56002G	-33.72	-13.00	-20.72	-	-
3.561G	3.57G	100k	300k	RMS	3.5615G	-28.75	-13.00	-15.75	MBW 1M	-
3.57G	3.72G	100k	300k	RMS	3.5705G	-46.38	-25.00	-21.38	MBW 1M	-
3.72G	3.8G	100k	300k	RMS	3.7785G	-52.53	-40.00	-12.53	MBW 1M	-

Band 48\_LTE\_10MHz\_Nss1,64QAM\_1TX  
3555MHz\_64QAM\_RB 1,#RB L

CSE-TX-Sum

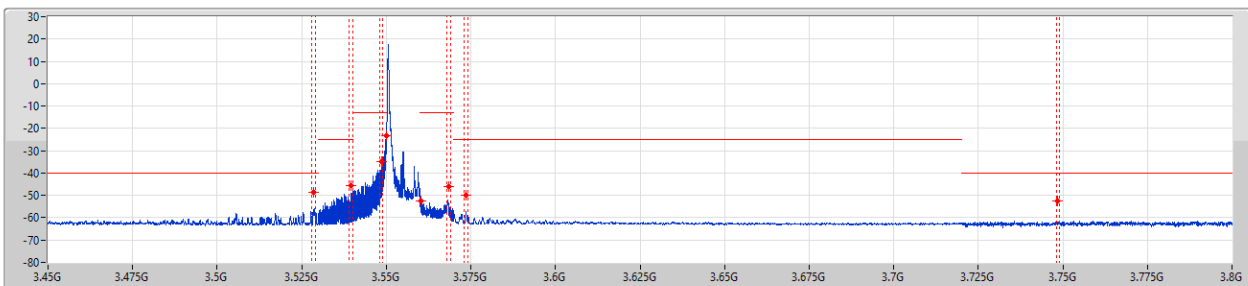

F.Start(Hz)	F.Stop(Hz)	RBW(Hz)	VBW(Hz)	Detector	Freq(Hz)	Level(dBm)	Limit(dBm)	Margin(dB)	Remark	Ref.Limit(dB)
3.45G	3.53G	100k	300k	RMS	3.5285G	-48.65	-40.00	-8.65	MBW 1M	-
3.53G	3.54G	100k	300k	RMS	3.5395G	-45.73	-25.00	-20.73	MBW 1M	-
3.54G	3.549G	100k	300k	RMS	3.5485G	-34.85	-13.00	-21.85	MBW 1M	-
3.549G	3.55G	100k	300k	RMS	3.54997G	-23.41	-13.00	-10.41	-	-
3.56G	3.561G	100k	300k	RMS	3.56017G	-52.50	-13.00	-39.50	-	-
3.561G	3.57G	100k	300k	RMS	3.5685G	-45.93	-13.00	-32.93	MBW 1M	-
3.57G	3.72G	100k	300k	RMS	3.5735G	-49.98	-25.00	-24.98	MBW 1M	-
3.72G	3.8G	100k	300k	RMS	3.7485G	-52.61	-40.00	-12.61	MBW 1M	-



Band 48\_LTE\_10MHz\_Nss1,64QAM\_1TX  
3625MHz\_64QAM\_RB 50,#RB 0

CSE-TX-Sum

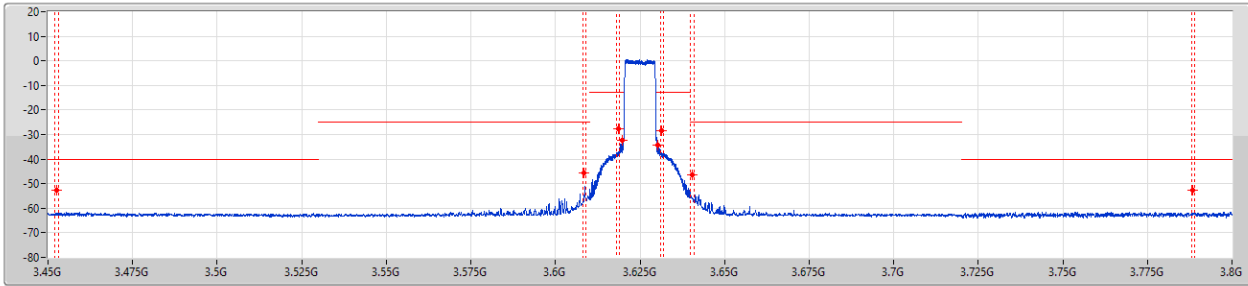

F-Start(Hz)	F-Stop(Hz)	RBW(Hz)	VBW(Hz)	Detector	Freq(Hz)	Level(dBm)	Limit(dBm)	Margin(dB)	Remark	Ref.Limit(dB)
3.45G	3.53G	100k	300k	RMS	3.4525G	-52.62	-40.00	-12.62	MBW 1M	-
3.53G	3.61G	100k	300k	RMS	3.6085G	-45.44	-25.00	-20.44	MBW 1M	-
3.61G	3.619G	100k	300k	RMS	3.6185G	-27.85	-13.00	-14.85	MBW 1M	-
3.619G	3.62G	100k	300k	RMS	3.61986G	-32.52	-13.00	-19.52	-	-
3.63G	3.631G	100k	300k	RMS	3.63013G	-34.22	-13.00	-21.22	-	-
3.631G	3.64G	100k	300k	RMS	3.6315G	-28.34	-13.00	-15.34	MBW 1M	-
3.64G	3.72G	100k	300k	RMS	3.6405G	-46.36	-25.00	-21.36	MBW 1M	-
3.72G	3.8G	100k	300k	RMS	3.7885G	-52.50	-40.00	-12.50	MBW 1M	-

Band 48\_LTE\_10MHz\_Nss1,64QAM\_1TX  
3625MHz\_64QAM\_RB 1,#RB L

CSE-TX-Sum

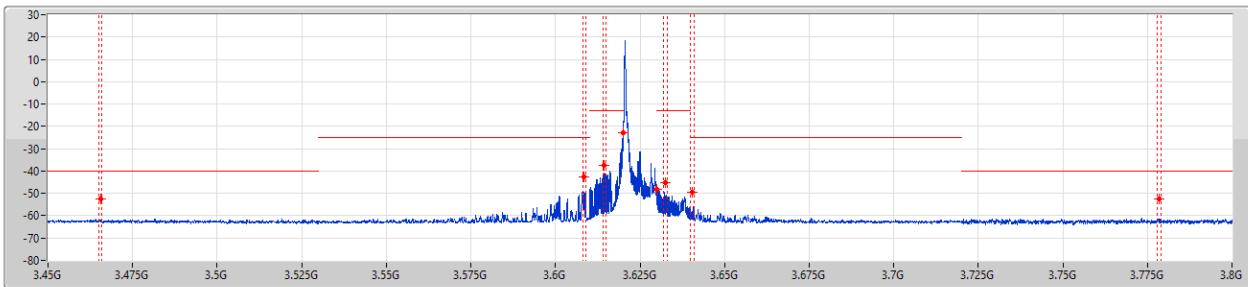

F-Start(Hz)	F-Stop(Hz)	RBW(Hz)	VBW(Hz)	Detector	Freq(Hz)	Level(dBm)	Limit(dBm)	Margin(dB)	Remark	Ref.Limit(dB)
3.45G	3.53G	100k	300k	RMS	3.4655G	-52.62	-40.00	-12.62	MBW 1M	-
3.53G	3.61G	100k	300k	RMS	3.6085G	-42.50	-25.00	-17.50	MBW 1M	-
3.61G	3.619G	100k	300k	RMS	3.6145G	-37.67	-13.00	-24.67	MBW 1M	-
3.619G	3.62G	100k	300k	RMS	3.61999G	-22.87	-13.00	-9.87	-	-
3.63G	3.631G	100k	300k	RMS	3.63008G	-48.11	-13.00	-35.11	-	-
3.631G	3.64G	100k	300k	RMS	3.6325G	-45.06	-13.00	-32.06	MBW 1M	-
3.64G	3.72G	100k	300k	RMS	3.6405G	-49.34	-25.00	-24.34	MBW 1M	-
3.72G	3.8G	100k	300k	RMS	3.7785G	-52.49	-40.00	-12.49	MBW 1M	-



Band 48\_LTE\_10MHz\_Nss1,64QAM\_1TX  
3695MHz\_64QAM\_RB 50,#RB 0

CSE-TX-Sum

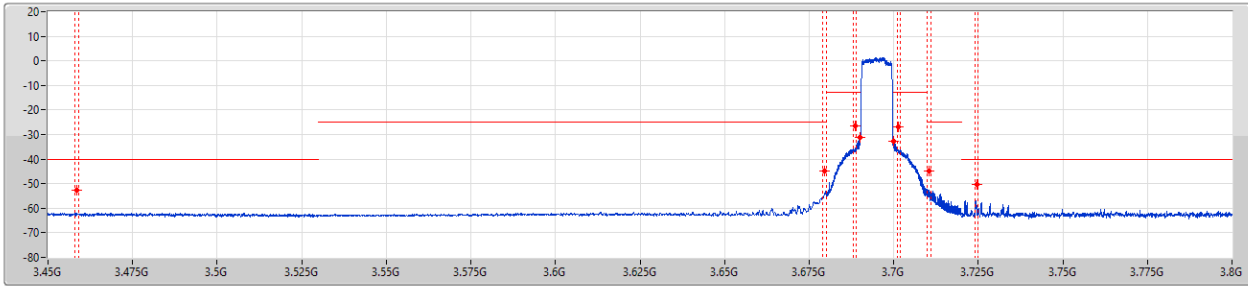

F-Start(Hz)	F-Stop(Hz)	RBW(Hz)	VBW(Hz)	Detector	Freq(Hz)	Level(dBm)	Limit(dBm)	Margin(dB)	Remark	Ref.Limit(dB)
3.45G	3.53G	100k	300k	RMS	3.4585G	-52.70	-40.00	-12.70	MBW 1M	-
3.53G	3.68G	100k	300k	RMS	3.6795G	-44.75	-25.00	-19.75	MBW 1M	-
3.68G	3.689G	100k	300k	RMS	3.6885G	-26.49	-13.00	-13.49	MBW 1M	-
3.689G	3.69G	100k	300k	RMS	3.69G	-31.20	-13.00	-18.20	-	-
3.7G	3.701G	100k	300k	RMS	3.70001G	-32.91	-13.00	-19.91	-	-
3.701G	3.71G	100k	300k	RMS	3.7015G	-27.00	-13.00	-14.00	MBW 1M	-
3.71G	3.72G	100k	300k	RMS	3.7105G	-44.98	-25.00	-19.98	MBW 1M	-
3.72G	3.8G	100k	300k	RMS	3.7245G	-50.22	-40.00	-10.22	MBW 1M	-

Band 48\_LTE\_10MHz\_Nss1,64QAM\_1TX  
3695MHz\_64QAM\_RB 1,#RB R

CSE-TX-Sum

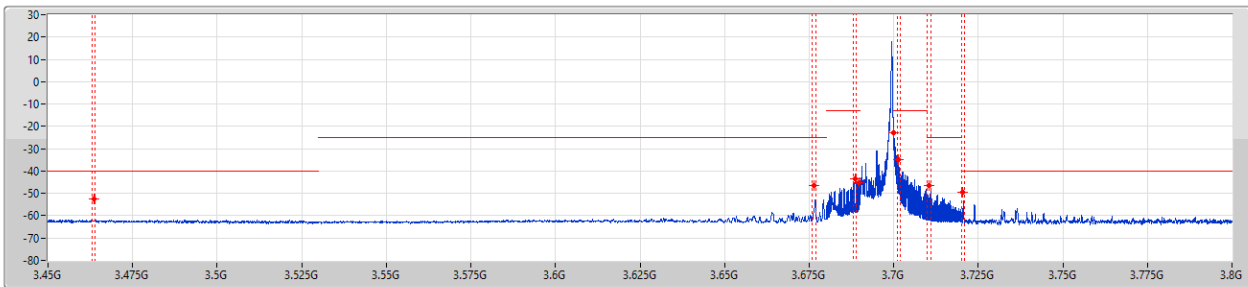

F-Start(Hz)	F-Stop(Hz)	RBW(Hz)	VBW(Hz)	Detector	Freq(Hz)	Level(dBm)	Limit(dBm)	Margin(dB)	Remark	Ref.Limit(dB)
3.45G	3.53G	100k	300k	RMS	3.4635G	-52.58	-40.00	-12.58	MBW 1M	-
3.53G	3.68G	100k	300k	RMS	3.6765G	-46.68	-25.00	-21.68	MBW 1M	-
3.68G	3.689G	100k	300k	RMS	3.6885G	-43.52	-13.00	-30.52	MBW 1M	-
3.689G	3.69G	100k	300k	RMS	3.6898G	-45.40	-13.00	-32.40	-	-
3.7G	3.701G	100k	300k	RMS	3.7G	-22.65	-13.00	-9.65	-	-
3.701G	3.71G	100k	300k	RMS	3.7015G	-34.81	-13.00	-21.81	MBW 1M	-
3.71G	3.72G	100k	300k	RMS	3.7105G	-46.69	-25.00	-21.69	MBW 1M	-
3.72G	3.8G	100k	300k	RMS	3.7205G	-49.39	-40.00	-9.39	MBW 1M	-



Band 48\_LTE\_10MHz\_Nss1,256QAM\_1TX  
3555MHz\_256QAM\_RB 50,#RB 0

CSE-TX-Sum

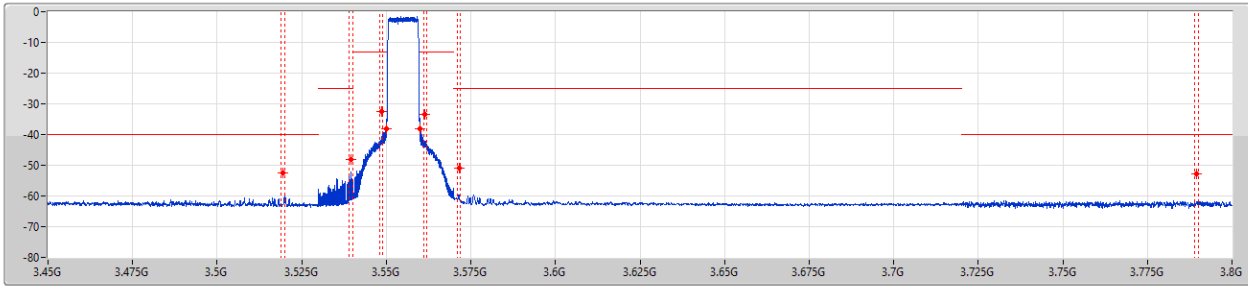

F-Start(Hz)	F-Stop(Hz)	RBW(Hz)	VBW(Hz)	Detector	Freq(Hz)	Level(dBm)	Limit(dBm)	Margin(dB)	Remark	Ref.Limit(dB)
3.45G	3.53G	100k	300k	RMS	3.5195G	-52.38	-40.00	-12.38	MBW 1M	-
3.53G	3.54G	100k	300k	RMS	3.5395G	-48.19	-25.00	-23.19	MBW 1M	-
3.54G	3.549G	100k	300k	RMS	3.5485G	-32.62	-13.00	-19.62	MBW 1M	-
3.549G	3.55G	100k	300k	RMS	3.54998G	-38.04	-13.00	-25.04	-	-
3.56G	3.561G	100k	300k	RMS	3.56G	-38.00	-13.00	-25.00	-	-
3.561G	3.57G	100k	300k	RMS	3.5615G	-33.56	-13.00	-20.56	MBW 1M	-
3.57G	3.72G	100k	300k	RMS	3.5715G	-51.09	-25.00	-26.09	MBW 1M	-
3.72G	3.8G	100k	300k	RMS	3.7895G	-52.66	-40.00	-12.66	MBW 1M	-

Band 48\_LTE\_10MHz\_Nss1,256QAM\_1TX  
3555MHz\_256QAM\_RB 1,#RB L

CSE-TX-Sum

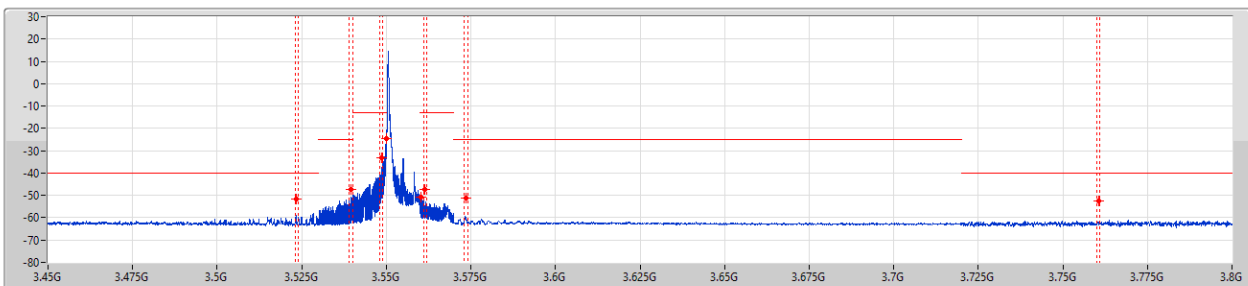

F-Start(Hz)	F-Stop(Hz)	RBW(Hz)	VBW(Hz)	Detector	Freq(Hz)	Level(dBm)	Limit(dBm)	Margin(dB)	Remark	Ref.Limit(dB)
3.45G	3.53G	100k	300k	RMS	3.5235G	-51.47	-40.00	-11.47	MBW 1M	-
3.53G	3.54G	100k	300k	RMS	3.5395G	-47.18	-25.00	-22.18	MBW 1M	-
3.54G	3.549G	100k	300k	RMS	3.5485G	-33.36	-13.00	-20.36	MBW 1M	-
3.549G	3.55G	100k	300k	RMS	3.54998G	-24.58	-13.00	-11.58	-	-
3.56G	3.561G	100k	300k	RMS	3.56021G	-50.85	-13.00	-37.85	-	-
3.561G	3.57G	100k	300k	RMS	3.5615G	-47.44	-13.00	-34.44	MBW 1M	-
3.57G	3.72G	100k	300k	RMS	3.5735G	-51.02	-25.00	-26.02	MBW 1M	-
3.72G	3.8G	100k	300k	RMS	3.7605G	-52.67	-40.00	-12.67	MBW 1M	-





Band 48\_LTE\_10MHz\_Nss1,256QAM\_1TX  
3625MHz\_256QAM\_RB 50,#RB 0

CSE-TX-Sum

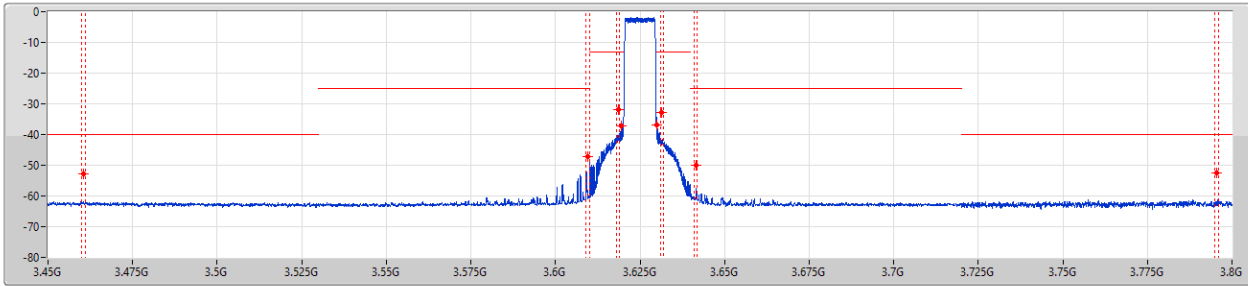

F-Start(Hz)	F-Stop(Hz)	RBW(Hz)	VBW(Hz)	Detector	Freq(Hz)	Level(dBm)	Limit(dBm)	Margin(dB)	Remark	Ref.Limit(dB)
3.45G	3.53G	100k	300k	RMS	3.4605G	-52.68	-40.00	-12.68	MBW 1M	-
3.53G	3.61G	100k	300k	RMS	3.6095G	-47.16	-25.00	-22.16	MBW 1M	-
3.61G	3.619G	100k	300k	RMS	3.6185G	-31.74	-13.00	-18.74	MBW 1M	-
3.619G	3.62G	100k	300k	RMS	3.61942G	-37.13	-13.00	-24.13	-	-
3.63G	3.631G	100k	300k	RMS	3.63008G	-36.92	-13.00	-23.92	-	-
3.631G	3.64G	100k	300k	RMS	3.6315G	-32.89	-13.00	-19.89	MBW 1M	-
3.64G	3.72G	100k	300k	RMS	3.6415G	-49.92	-25.00	-24.92	MBW 1M	-
3.72G	3.8G	100k	300k	RMS	3.7955G	-52.56	-40.00	-12.56	MBW 1M	-

Band 48\_LTE\_10MHz\_Nss1,256QAM\_1TX  
3625MHz\_256QAM\_RB 1,#RB L

CSE-TX-Sum

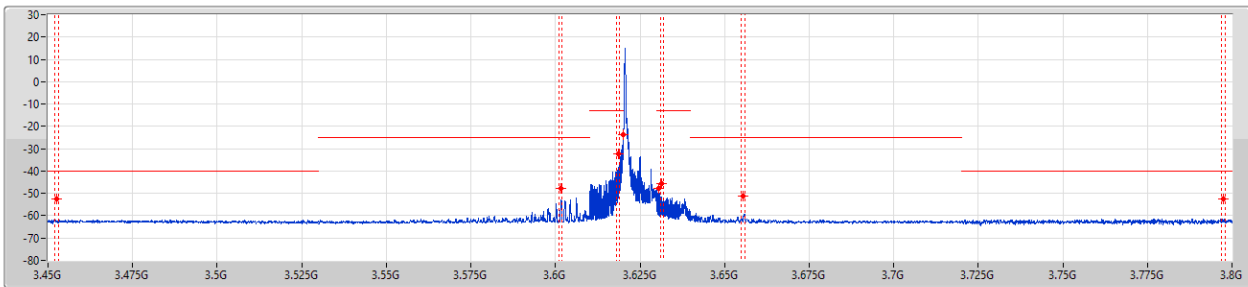

F-Start(Hz)	F-Stop(Hz)	RBW(Hz)	VBW(Hz)	Detector	Freq(Hz)	Level(dBm)	Limit(dBm)	Margin(dB)	Remark	Ref.Limit(dB)
3.45G	3.53G	100k	300k	RMS	3.4525G	-52.68	-40.00	-12.68	MBW 1M	-
3.53G	3.61G	100k	300k	RMS	3.6015G	-47.84	-25.00	-22.84	MBW 1M	-
3.61G	3.619G	100k	300k	RMS	3.6185G	-32.50	-13.00	-19.50	MBW 1M	-
3.619G	3.62G	100k	300k	RMS	3.62G	-23.84	-13.00	-10.84	-	-
3.63G	3.631G	100k	300k	RMS	3.63056G	-47.80	-13.00	-34.80	-	-
3.631G	3.64G	100k	300k	RMS	3.6315G	-45.76	-13.00	-32.76	MBW 1M	-
3.64G	3.72G	100k	300k	RMS	3.6555G	-51.15	-25.00	-26.15	MBW 1M	-
3.72G	3.8G	100k	300k	RMS	3.7975G	-52.58	-40.00	-12.58	MBW 1M	-



Band 48\_LTE\_10MHz\_Nss1,256QAM\_1TX  
3695MHz\_256QAM\_RB 50,#RB 0

CSE-TX-Sum

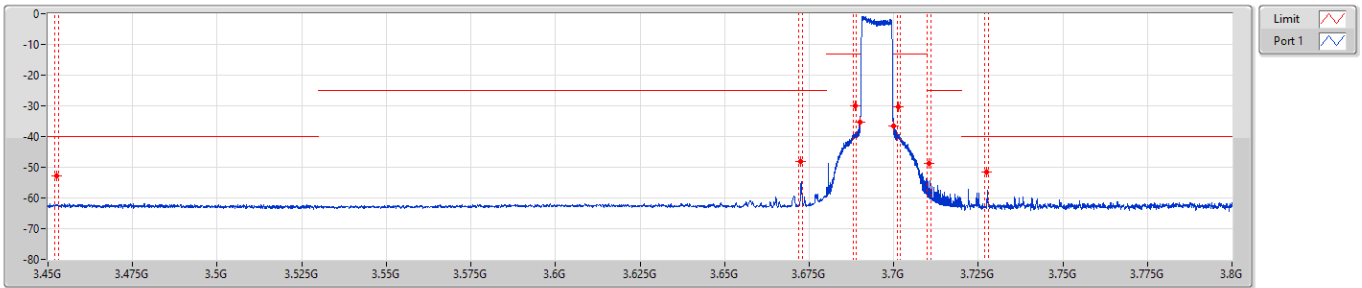

F-Start(Hz)	F-Stop(Hz)	RBW(Hz)	VBW(Hz)	Detector	Freq(Hz)	Level(dBm)	Limit(dBm)	Margin(dB)	Remark	Ref.Limit(dB)
3.45G	3.53G	100k	300k	RMS	3.4525G	-52.66	-40.00	-12.66	MBW 1M	-
3.53G	3.68G	100k	300k	RMS	3.6725G	-48.09	-25.00	-23.09	MBW 1M	-
3.68G	3.689G	100k	300k	RMS	3.6885G	-29.96	-13.00	-16.96	MBW 1M	-
3.689G	3.69G	100k	300k	RMS	3.68999G	-35.31	-13.00	-22.31	-	-
3.7G	3.701G	100k	300k	RMS	3.70003G	-36.51	-13.00	-23.51	-	-
3.701G	3.71G	100k	300k	RMS	3.7015G	-30.31	-13.00	-17.31	MBW 1M	-
3.71G	3.72G	100k	300k	RMS	3.7105G	-48.77	-25.00	-23.77	MBW 1M	-
3.72G	3.8G	100k	300k	RMS	3.7275G	-51.51	-40.00	-11.51	MBW 1M	-

Band 48\_LTE\_10MHz\_Nss1,256QAM\_1TX  
3695MHz\_256QAM\_RB 1,#RB R

CSE-TX-Sum

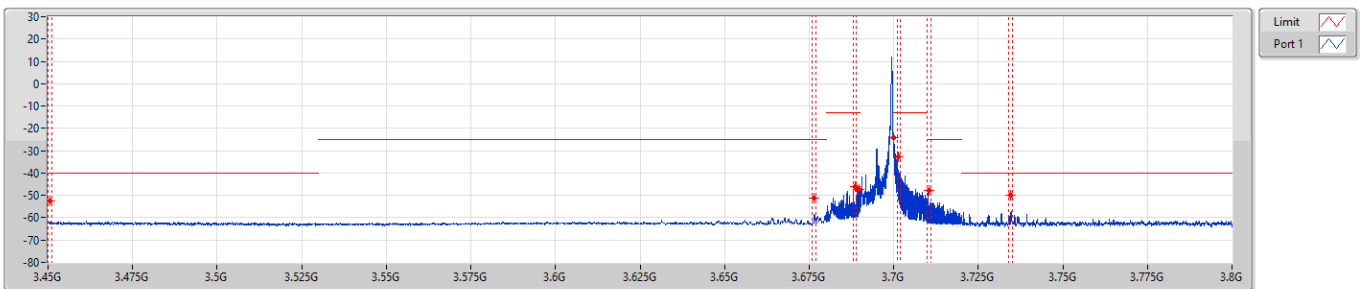

F-Start(Hz)	F-Stop(Hz)	RBW(Hz)	VBW(Hz)	Detector	Freq(Hz)	Level(dBm)	Limit(dBm)	Margin(dB)	Remark	Ref.Limit(dB)
3.45G	3.53G	100k	300k	RMS	3.4505G	-52.56	-40.00	-12.56	MBW 1M	-
3.53G	3.68G	100k	300k	RMS	3.6765G	-51.09	-25.00	-26.09	MBW 1M	-
3.68G	3.689G	100k	300k	RMS	3.6885G	-45.87	-13.00	-32.87	MBW 1M	-
3.689G	3.69G	100k	300k	RMS	3.68979G	-47.34	-13.00	-34.34	-	-
3.7G	3.701G	100k	300k	RMS	3.70003G	-24.25	-13.00	-11.25	-	-
3.701G	3.71G	100k	300k	RMS	3.7015G	-32.59	-13.00	-19.59	MBW 1M	-
3.71G	3.72G	100k	300k	RMS	3.7105G	-47.61	-25.00	-22.61	MBW 1M	-
3.72G	3.8G	100k	300k	RMS	3.7345G	-50.04	-40.00	-10.04	MBW 1M	-



Band 48\_LTE\_5MHz\_Nss1,QPSK\_1TX  
3552.5MHz\_QPSK\_RB 25,#RB 0

CSE-TX-Sum

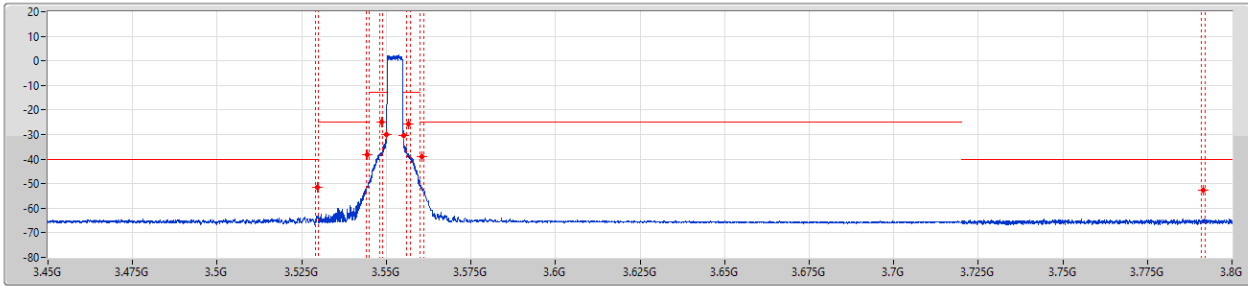

F-Start(Hz)	F-Stop(Hz)	RBW(Hz)	VBW(Hz)	Detector	Freq(Hz)	Level(dBm)	Limit(dBm)	Margin(dB)	Remark	Ref.Limit(dB)
3.45G	3.53G	50k	200k	RMS	3.5295G	-51.50	-40.00	-11.50	MBW 1M	-
3.53G	3.545G	50k	200k	RMS	3.5445G	-38.03	-25.00	-13.03	MBW 1M	-
3.545G	3.549G	50k	200k	RMS	3.5485G	-24.96	-13.00	-11.96	MBW 1M	-
3.549G	3.55G	50k	200k	RMS	3.55G	-30.18	-13.00	-17.18	-	-
3.555G	3.556G	50k	200k	RMS	3.55501G	-30.26	-13.00	-17.26	-	-
3.556G	3.56G	50k	200k	RMS	3.5565G	-25.52	-13.00	-12.52	MBW 1M	-
3.56G	3.72G	50k	200k	RMS	3.5605G	-39.13	-25.00	-14.13	MBW 1M	-
3.72G	3.8G	50k	200k	RMS	3.7915G	-52.50	-40.00	-12.50	MBW 1M	-

Band 48\_LTE\_5MHz\_Nss1,QPSK\_1TX  
3552.5MHz\_QPSK\_RB 1,#RB L

CSE-TX-Sum

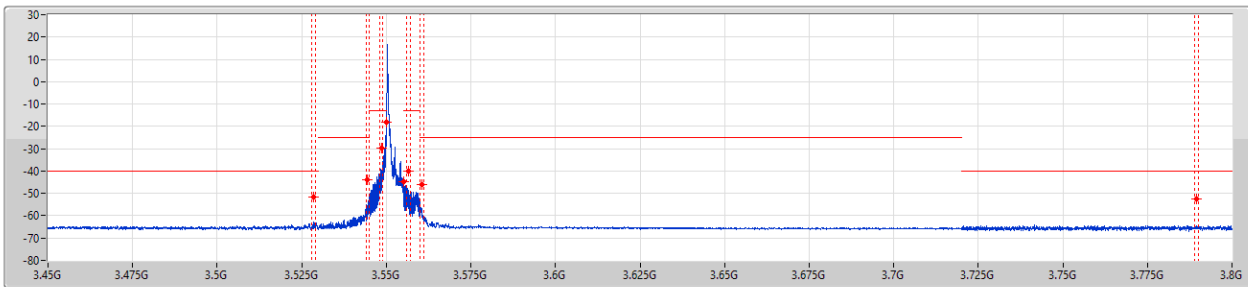

F-Start(Hz)	F-Stop(Hz)	RBW(Hz)	VBW(Hz)	Detector	Freq(Hz)	Level(dBm)	Limit(dBm)	Margin(dB)	Remark	Ref.Limit(dB)
3.45G	3.53G	50k	200k	RMS	3.5285G	-51.79	-40.00	-11.79	MBW 1M	-
3.53G	3.545G	50k	200k	RMS	3.5445G	-43.70	-25.00	-18.70	MBW 1M	-
3.545G	3.549G	50k	200k	RMS	3.5485G	-29.58	-13.00	-16.58	MBW 1M	-
3.549G	3.55G	50k	200k	RMS	3.54999G	-17.95	-13.00	-4.95	-	-
3.555G	3.556G	50k	200k	RMS	3.55501G	-44.91	-13.00	-31.91	-	-
3.556G	3.56G	50k	200k	RMS	3.5565G	-39.90	-13.00	-26.90	MBW 1M	-
3.56G	3.72G	50k	200k	RMS	3.5605G	-46.05	-25.00	-21.05	MBW 1M	-
3.72G	3.8G	50k	200k	RMS	3.7895G	-52.55	-40.00	-12.55	MBW 1M	-



Band 48\_LTE\_5MHz\_Nss1,QPSK\_1TX  
3625MHz\_QPSK\_RB 25,#RB 0

CSE-TX-Sum

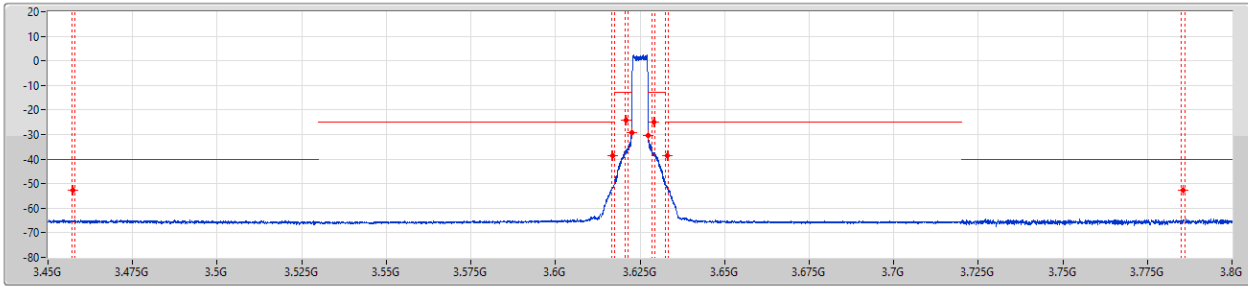

F-Start(Hz)	F-Stop(Hz)	RBW(Hz)	VBW(Hz)	Detector	Freq(Hz)	Level(dBm)	Limit(dBm)	Margin(dB)	Remark	Ref.Limit(dB)
3.45G	3.53G	50k	200k	RMS	3.4575G	-52.55	-40.00	-12.55	MBW 1M	-
3.53G	3.6175G	50k	200k	RMS	3.617G	-38.48	-25.00	-13.48	MBW 1M	-
3.6175G	3.6215G	50k	200k	RMS	3.621G	-24.03	-13.00	-11.03	MBW 1M	-
3.6215G	3.6225G	50k	200k	RMS	3.6225G	-29.40	-13.00	-16.40	-	-
3.6225G	3.6285G	50k	200k	RMS	3.6275G	-30.31	-13.00	-17.31	-	-
3.6285G	3.6325G	50k	200k	RMS	3.629G	-24.95	-13.00	-11.95	MBW 1M	-
3.6325G	3.72G	50k	200k	RMS	3.633G	-38.67	-25.00	-13.67	MBW 1M	-
3.72G	3.8G	50k	200k	RMS	3.7855G	-52.56	-40.00	-12.56	MBW 1M	-

Band 48\_LTE\_5MHz\_Nss1,QPSK\_1TX  
3625MHz\_QPSK\_RB 1,#RB L

CSE-TX-Sum

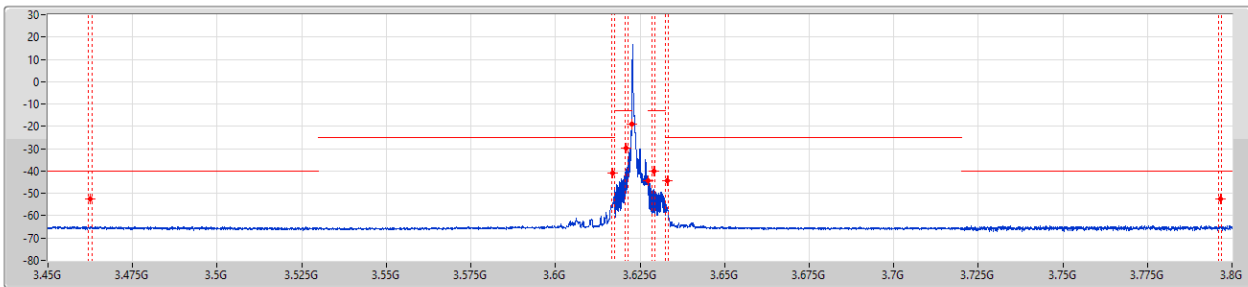

F-Start(Hz)	F-Stop(Hz)	RBW(Hz)	VBW(Hz)	Detector	Freq(Hz)	Level(dBm)	Limit(dBm)	Margin(dB)	Remark	Ref.Limit(dB)
3.45G	3.53G	50k	200k	RMS	3.4625G	-52.54	-40.00	-12.54	MBW 1M	-
3.53G	3.6175G	50k	200k	RMS	3.617G	-40.88	-25.00	-15.88	MBW 1M	-
3.6175G	3.6215G	50k	200k	RMS	3.621G	-29.62	-13.00	-16.62	MBW 1M	-
3.6215G	3.6225G	50k	200k	RMS	3.6225G	-18.81	-13.00	-5.81	-	-
3.6225G	3.6285G	50k	200k	RMS	3.6275G	-44.38	-13.00	-31.38	-	-
3.6285G	3.6325G	50k	200k	RMS	3.629G	-40.06	-13.00	-27.06	MBW 1M	-
3.6325G	3.72G	50k	200k	RMS	3.633G	-44.44	-25.00	-19.44	MBW 1M	-
3.72G	3.8G	50k	200k	RMS	3.7965G	-52.60	-40.00	-12.60	MBW 1M	-



Band 48\_LTE\_5MHz\_Nss1,QPSK\_1TX  
3697.5MHz\_QPSK\_RB 25,#RB 0

CSE-TX-Sum

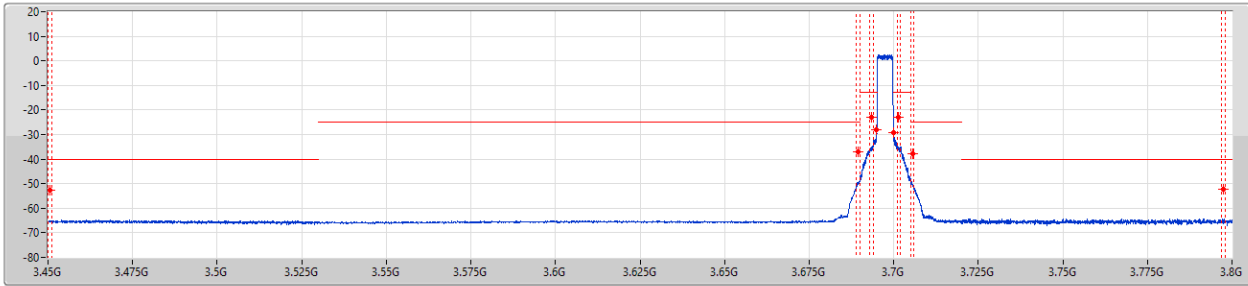

F-Start(Hz)	F-Stop(Hz)	RBW(Hz)	VBW(Hz)	Detector	Freq(Hz)	Level(dBm)	Limit(dBm)	Margin(dB)	Remark	Ref.Limit(dB)
3.45G	3.53G	50k	200k	RMS	3.4505G	-52.62	-40.00	-12.62	MBW 1M	-
3.53G	3.69G	50k	200k	RMS	3.6895G	-37.06	-25.00	-12.06	MBW 1M	-
3.69G	3.694G	50k	200k	RMS	3.6935G	-22.79	-13.00	-9.79	MBW 1M	-
3.694G	3.695G	50k	200k	RMS	3.69498G	-28.14	-13.00	-15.14	-	-
3.7G	3.701G	50k	200k	RMS	3.70001G	-29.18	-13.00	-16.18	-	-
3.701G	3.705G	50k	200k	RMS	3.7015G	-23.00	-13.00	-10.00	MBW 1M	-
3.705G	3.72G	50k	200k	RMS	3.7055G	-37.63	-25.00	-12.63	MBW 1M	-
3.72G	3.8G	50k	200k	RMS	3.7975G	-52.44	-40.00	-12.44	MBW 1M	-

Band 48\_LTE\_5MHz\_Nss1,QPSK\_1TX  
3697.5MHz\_QPSK\_RB 1,#RB R

CSE-TX-Sum

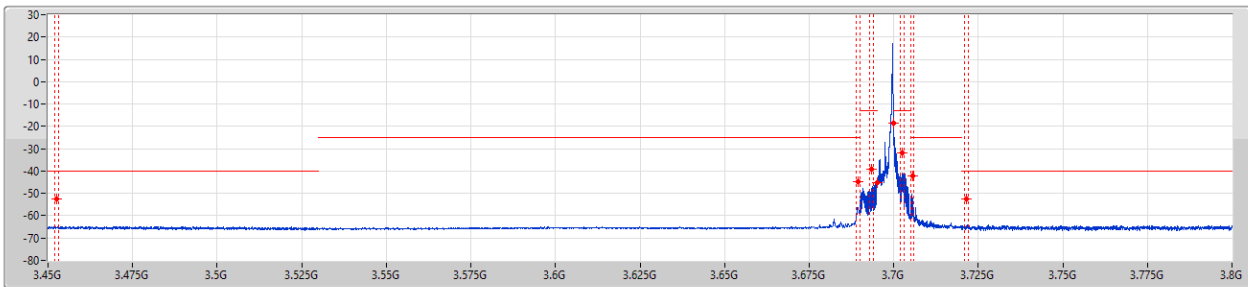

F-Start(Hz)	F-Stop(Hz)	RBW(Hz)	VBW(Hz)	Detector	Freq(Hz)	Level(dBm)	Limit(dBm)	Margin(dB)	Remark	Ref.Limit(dB)
3.45G	3.53G	50k	200k	RMS	3.4525G	-52.52	-40.00	-12.52	MBW 1M	-
3.53G	3.69G	50k	200k	RMS	3.6895G	-44.74	-25.00	-19.74	MBW 1M	-
3.69G	3.694G	50k	200k	RMS	3.6935G	-39.07	-13.00	-26.07	MBW 1M	-
3.694G	3.695G	50k	200k	RMS	3.695G	-45.00	-13.00	-32.00	-	-
3.7G	3.701G	50k	200k	RMS	3.7G	-18.69	-13.00	-5.69	-	-
3.701G	3.705G	50k	200k	RMS	3.7025G	-31.95	-13.00	-18.95	MBW 1M	-
3.705G	3.72G	50k	200k	RMS	3.7055G	-42.39	-25.00	-17.39	MBW 1M	-
3.72G	3.8G	50k	200k	RMS	3.7215G	-52.39	-40.00	-12.39	MBW 1M	-



**Band 48\_LTE\_5MHz\_Nss1,16QAM\_1TX**  
**3552.5MHz\_16QAM\_RB 25,#RB 0**

CSE-TX-Sum

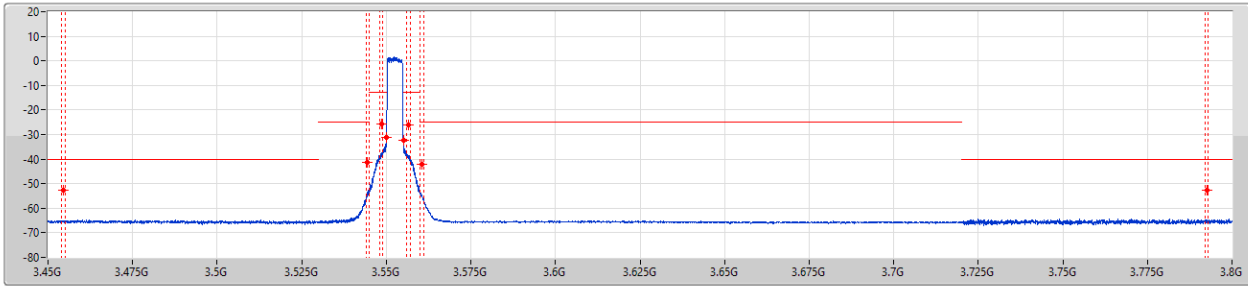

F-Start(Hz)	F-Stop(Hz)	RBW(Hz)	VBW(Hz)	Detector	Freq(Hz)	Level(dBm)	Limit(dBm)	Margin(dB)	Remark	Ref.Limit(dB)
3.45G	3.53G	50k	200k	RMS	3.4545G	-52.61	-40.00	-12.61	MBW 1M	-
3.53G	3.545G	50k	200k	RMS	3.5445G	-41.36	-25.00	-16.36	MBW 1M	-
3.545G	3.549G	50k	200k	RMS	3.5485G	-25.71	-13.00	-12.71	MBW 1M	-
3.549G	3.55G	50k	200k	RMS	3.55G	-31.30	-13.00	-18.30	-	-
3.555G	3.556G	50k	200k	RMS	3.55502G	-32.34	-13.00	-19.34	-	-
3.556G	3.56G	50k	200k	RMS	3.5565G	-26.19	-13.00	-13.19	MBW 1M	-
3.56G	3.72G	50k	200k	RMS	3.5605G	-41.99	-25.00	-16.99	MBW 1M	-
3.72G	3.8G	50k	200k	RMS	3.7925G	-52.49	-40.00	-12.49	MBW 1M	-

**Band 48\_LTE\_5MHz\_Nss1,16QAM\_1TX**  
**3552.5MHz\_16QAM\_RB 1,#RB L**

CSE-TX-Sum

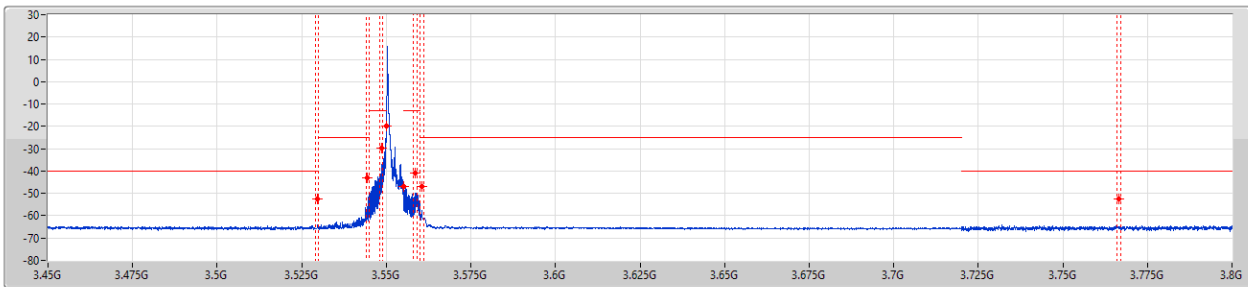

F-Start(Hz)	F-Stop(Hz)	RBW(Hz)	VBW(Hz)	Detector	Freq(Hz)	Level(dBm)	Limit(dBm)	Margin(dB)	Remark	Ref.Limit(dB)
3.45G	3.53G	50k	200k	RMS	3.5295G	-52.48	-40.00	-12.48	MBW 1M	-
3.53G	3.545G	50k	200k	RMS	3.5445G	-43.17	-25.00	-18.17	MBW 1M	-
3.545G	3.549G	50k	200k	RMS	3.5485G	-29.79	-13.00	-16.79	MBW 1M	-
3.549G	3.55G	50k	200k	RMS	3.55G	-19.84	-13.00	-6.84	-	-
3.555G	3.556G	50k	200k	RMS	3.55501G	-47.10	-13.00	-34.10	-	-
3.556G	3.56G	50k	200k	RMS	3.5585G	-40.71	-13.00	-27.71	MBW 1M	-
3.56G	3.72G	50k	200k	RMS	3.5605G	-46.86	-25.00	-21.86	MBW 1M	-
3.72G	3.8G	50k	200k	RMS	3.7665G	-52.57	-40.00	-12.57	MBW 1M	-



Band 48\_LTE\_5MHz\_Nss1,16QAM\_1TX  
3625MHz\_16QAM\_RB 25,#RB 0

CSE-TX-Sum

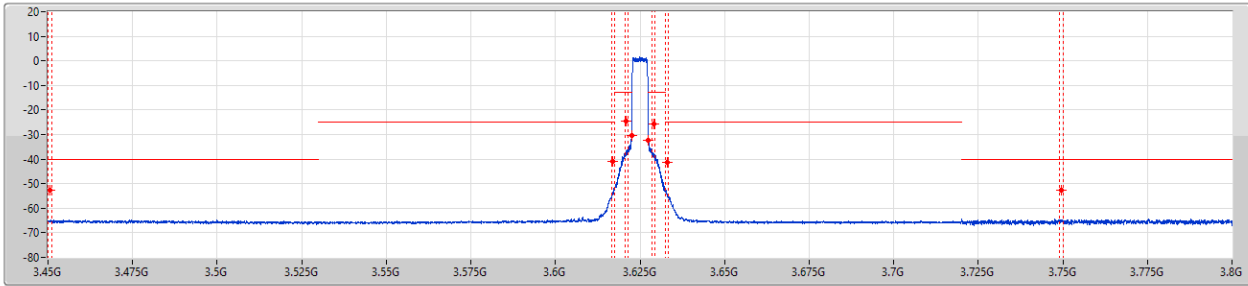

F-Start(Hz)	F-Stop(Hz)	RBW(Hz)	VBW(Hz)	Detector	Freq(Hz)	Level(dBm)	Limit(dBm)	Margin(dB)	Remark	Ref.Limit(dB)
3.45G	3.53G	50k	200k	RMS	3.4505G	-52.54	-40.00	-12.54	MBW 1M	-
3.53G	3.6175G	50k	200k	RMS	3.617G	-40.88	-25.00	-15.88	MBW 1M	-
3.6175G	3.6215G	50k	200k	RMS	3.621G	-24.66	-13.00	-11.66	MBW 1M	-
3.6215G	3.6225G	50k	200k	RMS	3.6225G	-30.24	-13.00	-17.24	-	-
3.6225G	3.6285G	50k	200k	RMS	3.62752G	-32.44	-13.00	-19.44	-	-
3.6285G	3.6325G	50k	200k	RMS	3.629G	-25.62	-13.00	-12.62	MBW 1M	-
3.6325G	3.72G	50k	200k	RMS	3.633G	-41.42	-25.00	-16.42	MBW 1M	-
3.72G	3.8G	50k	200k	RMS	3.7495G	-52.51	-40.00	-12.51	MBW 1M	-

Band 48\_LTE\_5MHz\_Nss1,16QAM\_1TX  
3625MHz\_16QAM\_RB 1,#RB L

CSE-TX-Sum

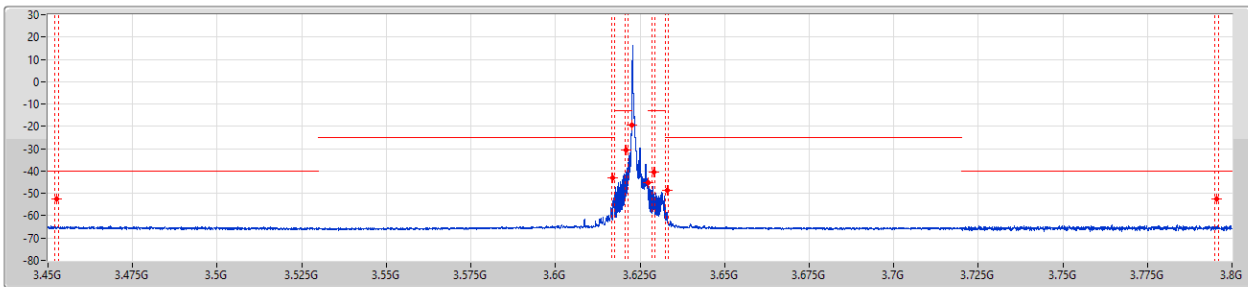

F-Start(Hz)	F-Stop(Hz)	RBW(Hz)	VBW(Hz)	Detector	Freq(Hz)	Level(dBm)	Limit(dBm)	Margin(dB)	Remark	Ref.Limit(dB)
3.45G	3.53G	50k	200k	RMS	3.4525G	-52.59	-40.00	-12.59	MBW 1M	-
3.53G	3.6175G	50k	200k	RMS	3.617G	-42.92	-25.00	-17.92	MBW 1M	-
3.6175G	3.6215G	50k	200k	RMS	3.621G	-30.38	-13.00	-17.38	MBW 1M	-
3.6215G	3.6225G	50k	200k	RMS	3.62248G	-19.58	-13.00	-6.58	-	-
3.6225G	3.6285G	50k	200k	RMS	3.62752G	-45.39	-13.00	-32.39	-	-
3.6285G	3.6325G	50k	200k	RMS	3.629G	-40.42	-13.00	-27.42	MBW 1M	-
3.6325G	3.72G	50k	200k	RMS	3.633G	-48.53	-25.00	-23.53	MBW 1M	-
3.72G	3.8G	50k	200k	RMS	3.7955G	-52.57	-40.00	-12.57	MBW 1M	-



Band 48\_LTE\_5MHz\_Nss1,16QAM\_1TX  
3697.5MHz\_16QAM\_RB 25,#RB 0

CSE-TX-Sum

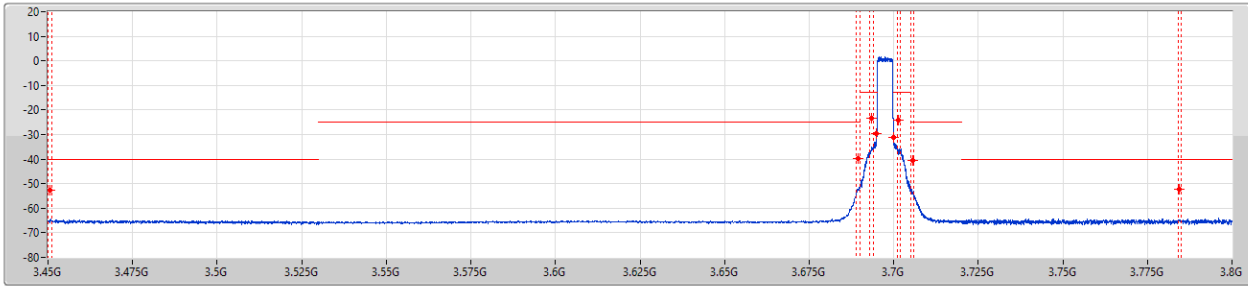

F-Start(Hz)	F-Stop(Hz)	RBW(Hz)	VBW(Hz)	Detector	Freq(Hz)	Level(dBm)	Limit(dBm)	Margin(dB)	Remark	Ref.Limit(dB)
3.45G	3.53G	50k	200k	RMS	3.4505G	-52.57	-40.00	-12.57	MBW 1M	-
3.53G	3.69G	50k	200k	RMS	3.6895G	-39.67	-25.00	-14.67	MBW 1M	-
3.69G	3.694G	50k	200k	RMS	3.6935G	-23.39	-13.00	-10.39	MBW 1M	-
3.694G	3.695G	50k	200k	RMS	3.69498G	-29.75	-13.00	-16.75	-	-
3.7G	3.701G	50k	200k	RMS	3.7G	-31.17	-13.00	-18.17	-	-
3.701G	3.705G	50k	200k	RMS	3.7015G	-24.31	-13.00	-11.31	MBW 1M	-
3.705G	3.72G	50k	200k	RMS	3.7055G	-40.72	-25.00	-15.72	MBW 1M	-
3.72G	3.8G	50k	200k	RMS	3.7845G	-52.46	-40.00	-12.46	MBW 1M	-

Band 48\_LTE\_5MHz\_Nss1,16QAM\_1TX  
3697.5MHz\_16QAM\_RB 1,#RB R

CSE-TX-Sum

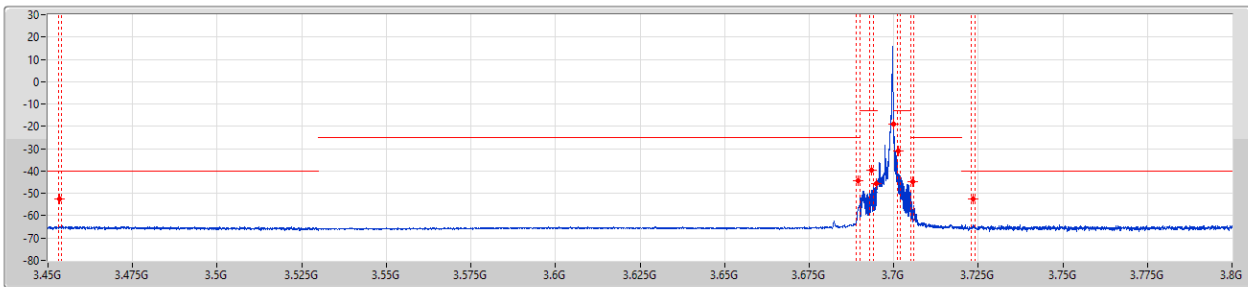

F-Start(Hz)	F-Stop(Hz)	RBW(Hz)	VBW(Hz)	Detector	Freq(Hz)	Level(dBm)	Limit(dBm)	Margin(dB)	Remark	Ref.Limit(dB)
3.45G	3.53G	50k	200k	RMS	3.4535G	-52.56	-40.00	-12.56	MBW 1M	-
3.53G	3.69G	50k	200k	RMS	3.6895G	-44.51	-25.00	-19.51	MBW 1M	-
3.69G	3.694G	50k	200k	RMS	3.6935G	-39.66	-13.00	-26.66	MBW 1M	-
3.694G	3.695G	50k	200k	RMS	3.69492G	-45.65	-13.00	-32.65	-	-
3.7G	3.701G	50k	200k	RMS	3.7G	-18.83	-13.00	-5.83	-	-
3.701G	3.705G	50k	200k	RMS	3.7015G	-31.08	-13.00	-18.08	MBW 1M	-
3.705G	3.72G	50k	200k	RMS	3.7055G	-44.66	-25.00	-19.66	MBW 1M	-
3.72G	3.8G	50k	200k	RMS	3.7235G	-52.41	-40.00	-12.41	MBW 1M	-





Band 48\_LTE\_5MHz\_Nss1,64QAM\_1TX  
3552.5MHz\_64QAM\_RB 25,#RB 0

CSE-TX-Sum

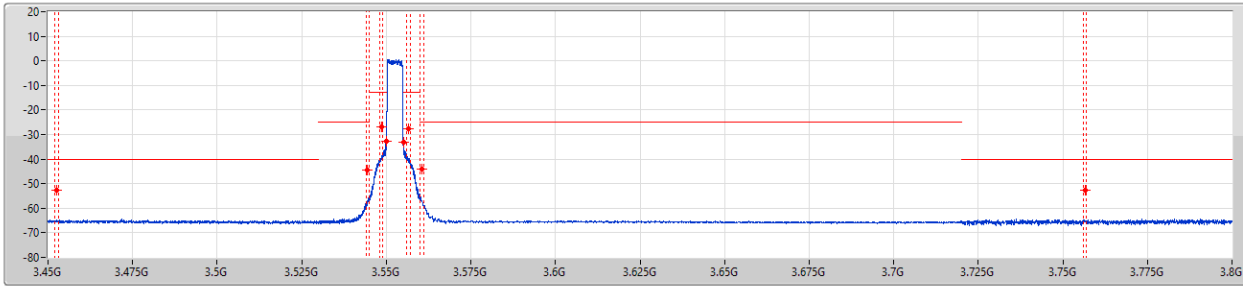

F-Start(Hz)	F-Stop(Hz)	RBW(Hz)	VBW(Hz)	Detector	Freq(Hz)	Level(dBm)	Limit(dBm)	Margin(dB)	Remark	Ref.Limit(dB)
3.45G	3.53G	50k	200k	RMS	3.4525G	-52.50	-40.00	-12.50	MBW 1M	-
3.53G	3.545G	50k	200k	RMS	3.5445G	-44.52	-25.00	-19.52	MBW 1M	-
3.545G	3.549G	50k	200k	RMS	3.5485G	-27.02	-13.00	-14.02	MBW 1M	-
3.549G	3.55G	50k	200k	RMS	3.54999G	-32.80	-13.00	-19.80	-	-
3.555G	3.556G	50k	200k	RMS	3.55501G	-33.16	-13.00	-20.16	-	-
3.556G	3.56G	50k	200k	RMS	3.5565G	-27.52	-13.00	-14.52	MBW 1M	-
3.56G	3.72G	50k	200k	RMS	3.5605G	-44.04	-25.00	-19.04	MBW 1M	-
3.72G	3.8G	50k	200k	RMS	3.7565G	-52.64	-40.00	-12.64	MBW 1M	-

Band 48\_LTE\_5MHz\_Nss1,64QAM\_1TX  
3552.5MHz\_64QAM\_RB 1,#RB L

CSE-TX-Sum

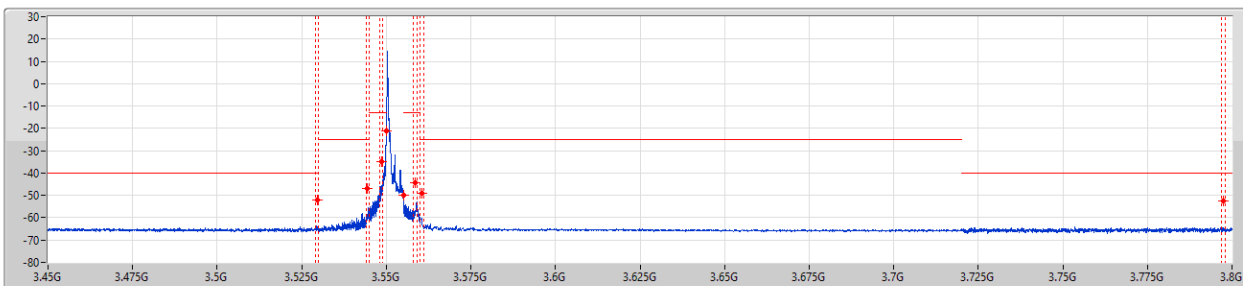

F-Start(Hz)	F-Stop(Hz)	RBW(Hz)	VBW(Hz)	Detector	Freq(Hz)	Level(dBm)	Limit(dBm)	Margin(dB)	Remark	Ref.Limit(dB)
3.45G	3.53G	50k	200k	RMS	3.5295G	-52.20	-40.00	-12.20	MBW 1M	-
3.53G	3.545G	50k	200k	RMS	3.5445G	-46.71	-25.00	-21.71	MBW 1M	-
3.545G	3.549G	50k	200k	RMS	3.5485G	-34.95	-13.00	-21.95	MBW 1M	-
3.549G	3.55G	50k	200k	RMS	3.54998G	-21.22	-13.00	-8.22	-	-
3.555G	3.556G	50k	200k	RMS	3.555G	-50.12	-13.00	-37.12	-	-
3.556G	3.56G	50k	200k	RMS	3.5585G	-44.18	-13.00	-31.18	MBW 1M	-
3.56G	3.72G	50k	200k	RMS	3.5605G	-49.01	-25.00	-24.01	MBW 1M	-
3.72G	3.8G	50k	200k	RMS	3.7975G	-52.57	-40.00	-12.57	MBW 1M	-



Band 48\_LTE\_5MHz\_Nss1,64QAM\_1TX  
3625MHz\_64QAM\_RB 25,#RB 0

CSE-TX-Sum

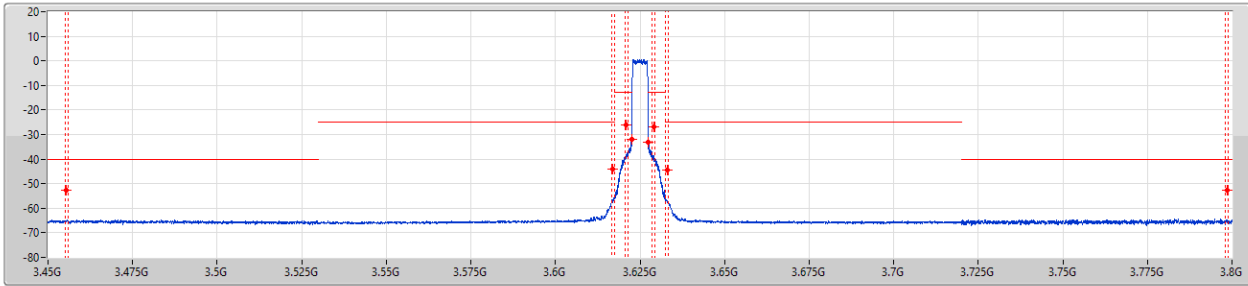

F.Start(Hz)	F.Stop(Hz)	RBW(Hz)	VBW(Hz)	Detector	Freq(Hz)	Level(dBm)	Limit(dBm)	Margin(dB)	Remark	Ref.Limit(dB)
3.45G	3.53G	50k	200k	RMS	3.4555G	-52.56	-40.00	-12.56	MBW 1M	-
3.53G	3.6175G	50k	200k	RMS	3.617G	-43.97	-25.00	-18.97	MBW 1M	-
3.6175G	3.6215G	50k	200k	RMS	3.621G	-25.98	-13.00	-12.98	MBW 1M	-
3.6215G	3.6225G	50k	200k	RMS	3.62248G	-31.84	-13.00	-18.84	-	-
3.6225G	3.6285G	50k	200k	RMS	3.62751G	-33.25	-13.00	-20.25	-	-
3.6285G	3.6325G	50k	200k	RMS	3.629G	-26.87	-13.00	-13.87	MBW 1M	-
3.6325G	3.72G	50k	200k	RMS	3.633G	-44.32	-25.00	-19.32	MBW 1M	-
3.72G	3.8G	50k	200k	RMS	3.7985G	-52.58	-40.00	-12.58	MBW 1M	-

Band 48\_LTE\_5MHz\_Nss1,64QAM\_1TX  
3625MHz\_64QAM\_RB 1,#RB L

CSE-TX-Sum

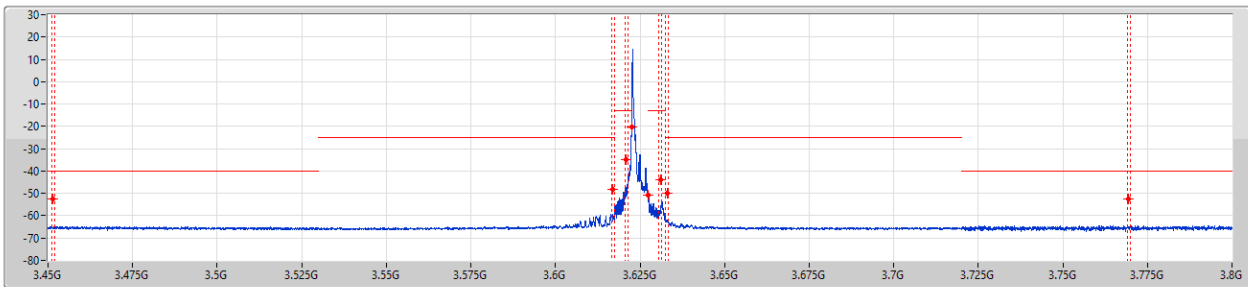

F.Start(Hz)	F.Stop(Hz)	RBW(Hz)	VBW(Hz)	Detector	Freq(Hz)	Level(dBm)	Limit(dBm)	Margin(dB)	Remark	Ref.Limit(dB)
3.45G	3.53G	50k	200k	RMS	3.4515G	-52.59	-40.00	-12.59	MBW 1M	-
3.53G	3.6175G	50k	200k	RMS	3.617G	-48.19	-25.00	-23.19	MBW 1M	-
3.6175G	3.6215G	50k	200k	RMS	3.621G	-35.09	-13.00	-22.09	MBW 1M	-
3.6215G	3.6225G	50k	200k	RMS	3.6225G	-20.45	-13.00	-7.45	-	-
3.6225G	3.6285G	50k	200k	RMS	3.62755G	-50.71	-13.00	-37.71	-	-
3.6285G	3.6325G	50k	200k	RMS	3.631G	-43.95	-13.00	-30.95	MBW 1M	-
3.6325G	3.72G	50k	200k	RMS	3.633G	-49.72	-25.00	-24.72	MBW 1M	-
3.72G	3.8G	50k	200k	RMS	3.7695G	-52.50	-40.00	-12.50	MBW 1M	-

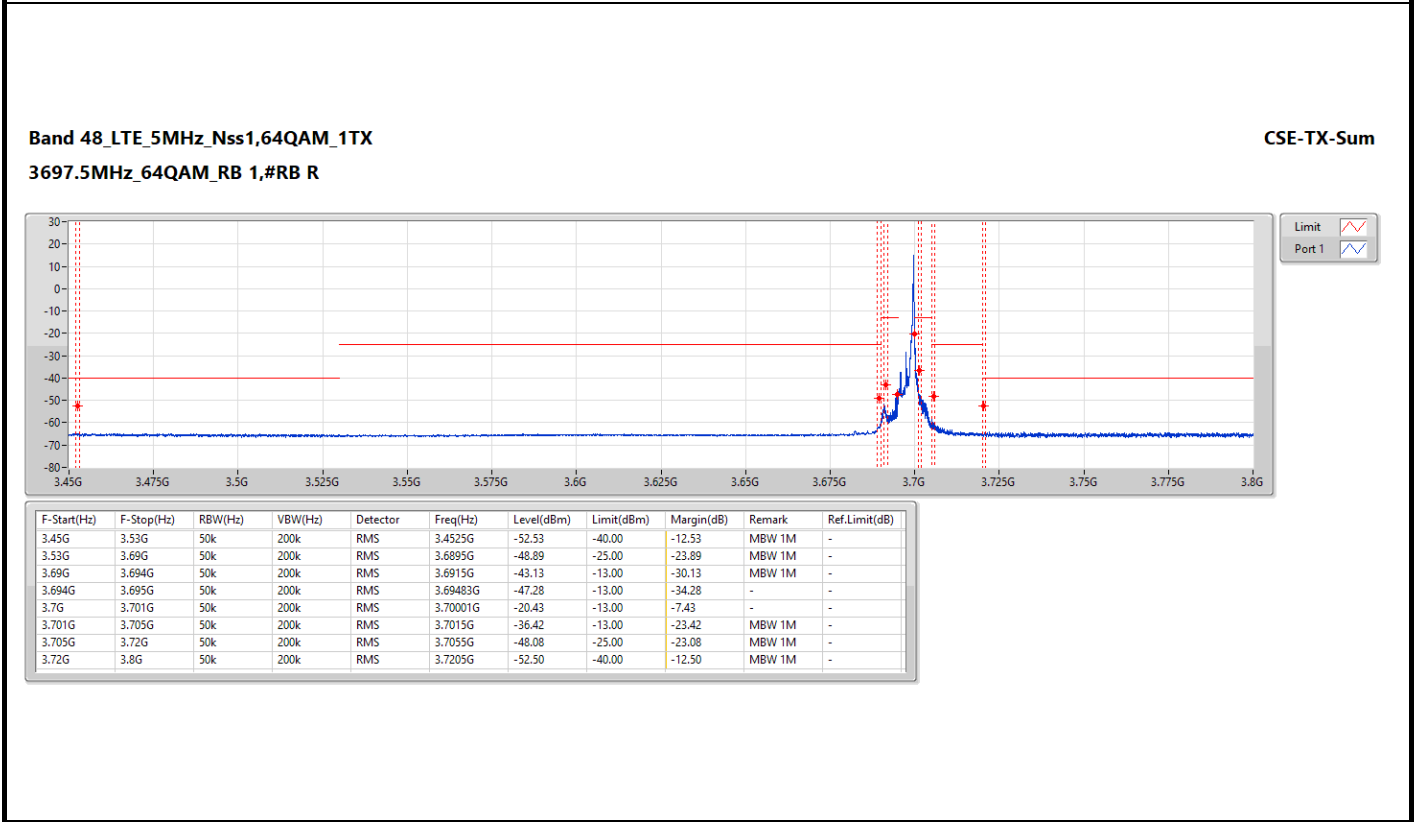
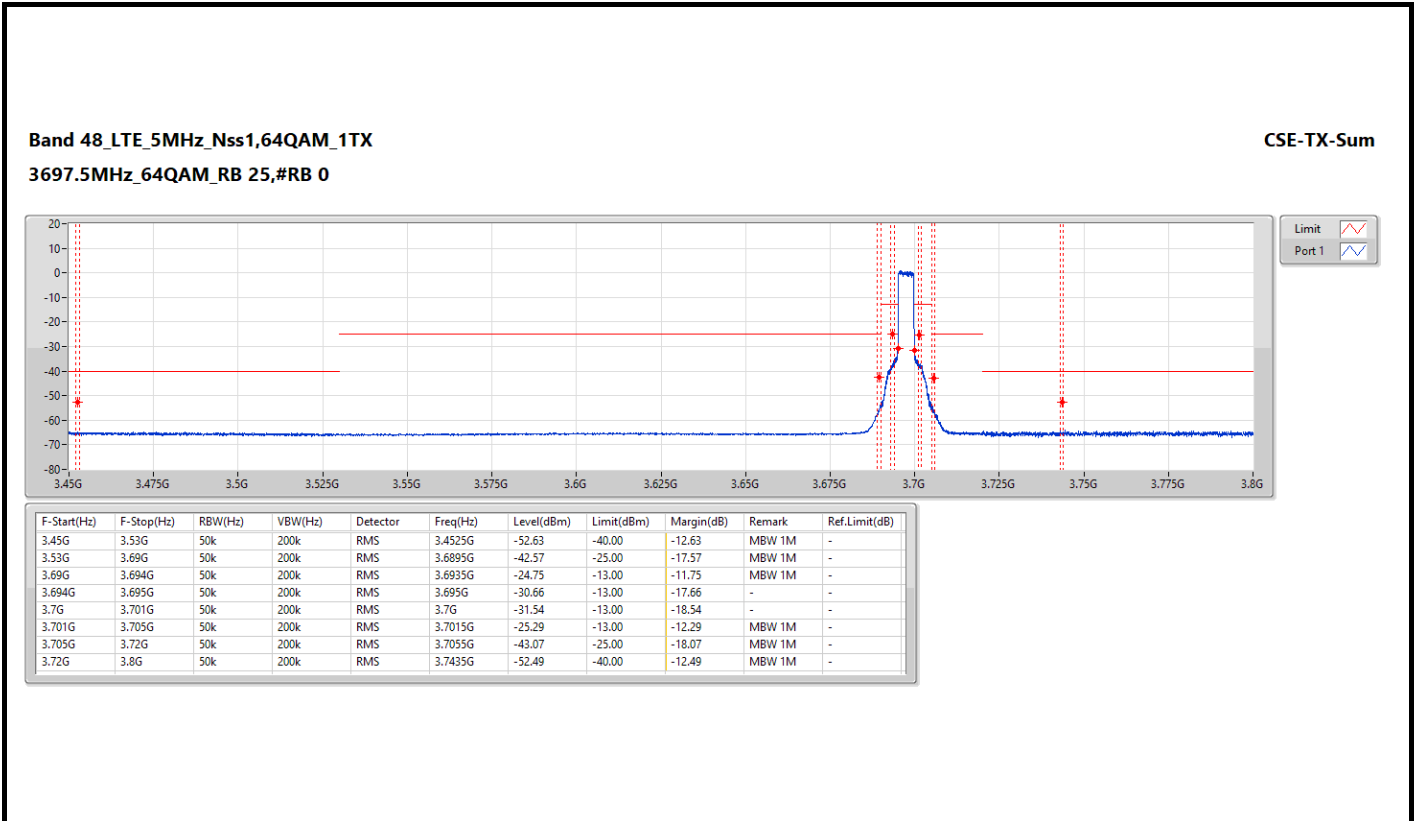



Band 48\_LTE\_5MHz\_Nss1,256QAM\_1TX  
3552.5MHz\_256QAM\_RB 25,#RB 0

CSE-TX-Sum

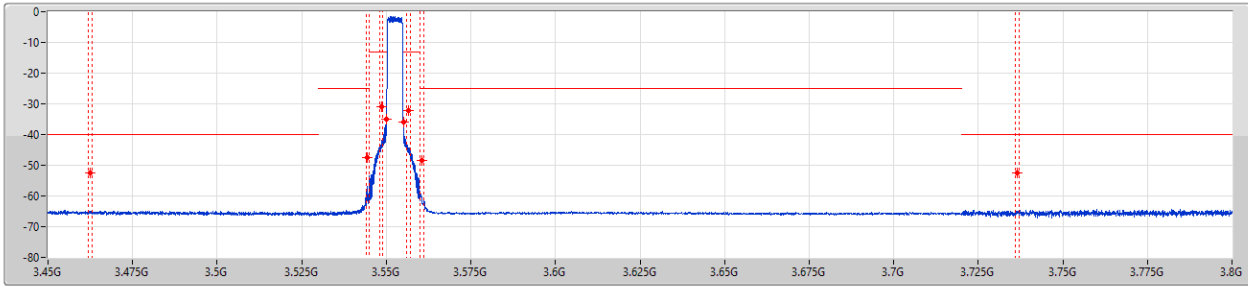

F-Start(Hz)	F-Stop(Hz)	RBW(Hz)	VBW(Hz)	Detector	Freq(Hz)	Level(dBm)	Limit(dBm)	Margin(dB)	Remark	Ref.Limit(dB)
3.45G	3.53G	50k	200k	RMS	3.4625G	-52.62	-40.00	-12.62	MBW 1M	-
3.53G	3.545G	50k	200k	RMS	3.5445G	-47.40	-25.00	-22.40	MBW 1M	-
3.545G	3.549G	50k	200k	RMS	3.5485G	-31.06	-13.00	-18.06	MBW 1M	-
3.549G	3.55G	50k	200k	RMS	3.55G	-34.87	-13.00	-21.87	-	-
3.555G	3.556G	50k	200k	RMS	3.55502G	-35.94	-13.00	-22.94	-	-
3.556G	3.56G	50k	200k	RMS	3.5565G	-32.28	-13.00	-19.28	MBW 1M	-
3.56G	3.72G	50k	200k	RMS	3.5605G	-48.34	-25.00	-23.34	MBW 1M	-
3.72G	3.8G	50k	200k	RMS	3.7365G	-52.65	-40.00	-12.65	MBW 1M	-

Band 48\_LTE\_5MHz\_Nss1,256QAM\_1TX  
3552.5MHz\_256QAM\_RB 1,#RB L

CSE-TX-Sum

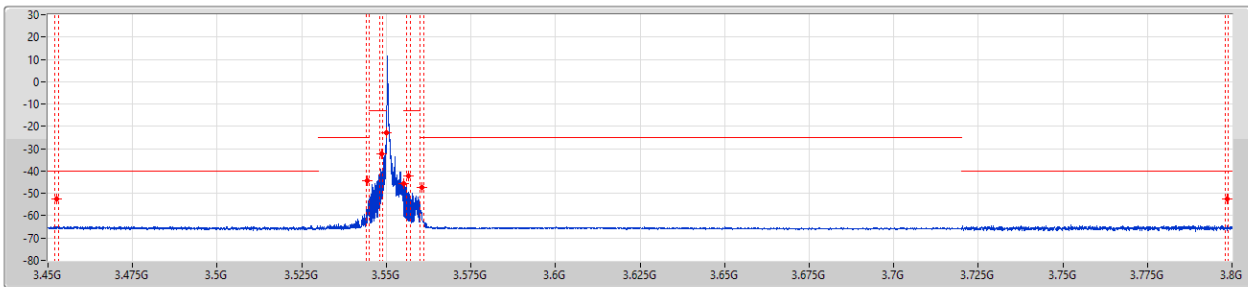

F-Start(Hz)	F-Stop(Hz)	RBW(Hz)	VBW(Hz)	Detector	Freq(Hz)	Level(dBm)	Limit(dBm)	Margin(dB)	Remark	Ref.Limit(dB)
3.45G	3.53G	50k	200k	RMS	3.4525G	-52.63	-40.00	-12.63	MBW 1M	-
3.53G	3.545G	50k	200k	RMS	3.5445G	-44.50	-25.00	-19.50	MBW 1M	-
3.545G	3.549G	50k	200k	RMS	3.5485G	-32.33	-13.00	-19.33	MBW 1M	-
3.549G	3.55G	50k	200k	RMS	3.54999G	-22.89	-13.00	-9.89	-	-
3.555G	3.556G	50k	200k	RMS	3.55506G	-45.83	-13.00	-32.83	-	-
3.556G	3.56G	50k	200k	RMS	3.5565G	-41.99	-13.00	-28.99	MBW 1M	-
3.56G	3.72G	50k	200k	RMS	3.5605G	-47.35	-25.00	-22.35	MBW 1M	-
3.72G	3.8G	50k	200k	RMS	3.7985G	-52.52	-40.00	-12.52	MBW 1M	-



Band 48\_LTE\_5MHz\_Nss1,256QAM\_1TX  
3625MHz\_256QAM\_RB 25,#RB 0

CSE-TX-Sum

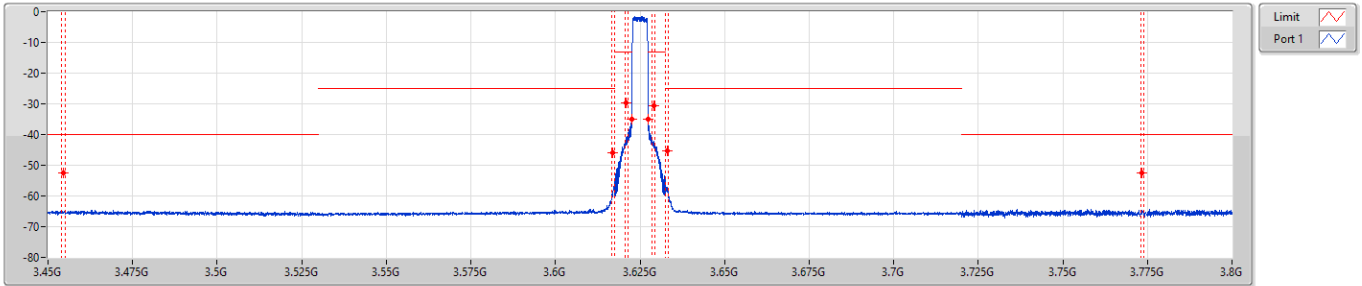

F-Start(Hz)	F-Stop(Hz)	RBW(Hz)	VBW(Hz)	Detector	Freq(Hz)	Level(dBm)	Limit(dBm)	Margin(dB)	Remark	Ref.Limit(dB)
3.45G	3.53G	50k	200k	RMS	3.4545G	-52.62	-40.00	-12.62	MBW 1M	-
3.53G	3.6175G	50k	200k	RMS	3.617G	-46.04	-25.00	-21.04	MBW 1M	-
3.6175G	3.6215G	50k	200k	RMS	3.621G	-29.63	-13.00	-16.63	MBW 1M	-
3.6215G	3.6225G	50k	200k	RMS	3.62249G	-34.85	-13.00	-21.85	-	-
3.6225G	3.6285G	50k	200k	RMS	3.6275G	-34.86	-13.00	-21.86	-	-
3.6285G	3.6325G	50k	200k	RMS	3.629G	-30.70	-13.00	-17.70	MBW 1M	-
3.6325G	3.72G	50k	200k	RMS	3.633G	-45.44	-25.00	-20.44	MBW 1M	-
3.72G	3.8G	50k	200k	RMS	3.7735G	-52.58	-40.00	-12.58	MBW 1M	-

Band 48\_LTE\_5MHz\_Nss1,256QAM\_1TX  
3625MHz\_256QAM\_RB 1,#RB L

CSE-TX-Sum

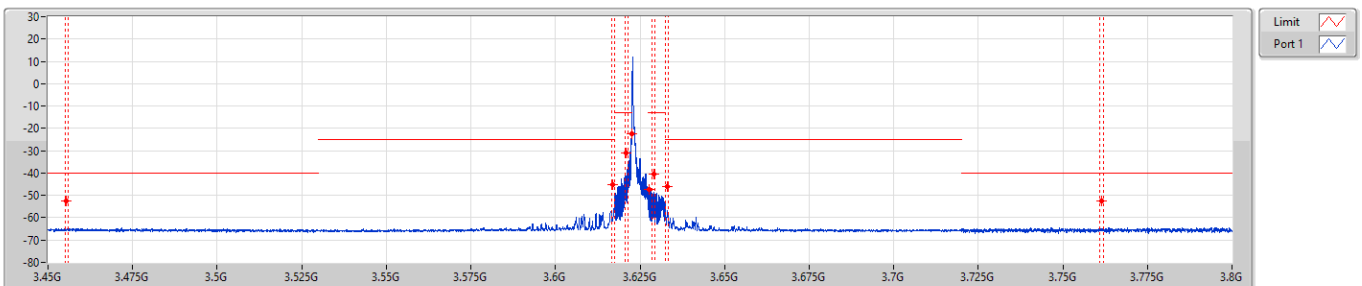

F-Start(Hz)	F-Stop(Hz)	RBW(Hz)	VBW(Hz)	Detector	Freq(Hz)	Level(dBm)	Limit(dBm)	Margin(dB)	Remark	Ref.Limit(dB)
3.45G	3.53G	50k	200k	RMS	3.4555G	-52.67	-40.00	-12.67	MBW 1M	-
3.53G	3.6175G	50k	200k	RMS	3.617G	-45.34	-25.00	-20.34	MBW 1M	-
3.6175G	3.6215G	50k	200k	RMS	3.621G	-30.99	-13.00	-17.99	MBW 1M	-
3.6215G	3.6225G	50k	200k	RMS	3.6225G	-22.46	-13.00	-9.46	-	-
3.6225G	3.6285G	50k	200k	RMS	3.6277G	-47.17	-13.00	-34.17	-	-
3.6285G	3.6325G	50k	200k	RMS	3.629G	-40.54	-13.00	-27.54	MBW 1M	-
3.6325G	3.72G	50k	200k	RMS	3.633G	-46.15	-25.00	-21.15	MBW 1M	-
3.72G	3.8G	50k	200k	RMS	3.7615G	-52.53	-40.00	-12.53	MBW 1M	-



Band 48\_LTE\_5MHz\_Nss1,256QAM\_1TX  
3697.5MHz\_256QAM\_RB 25,#RB 0

CSE-TX-Sum

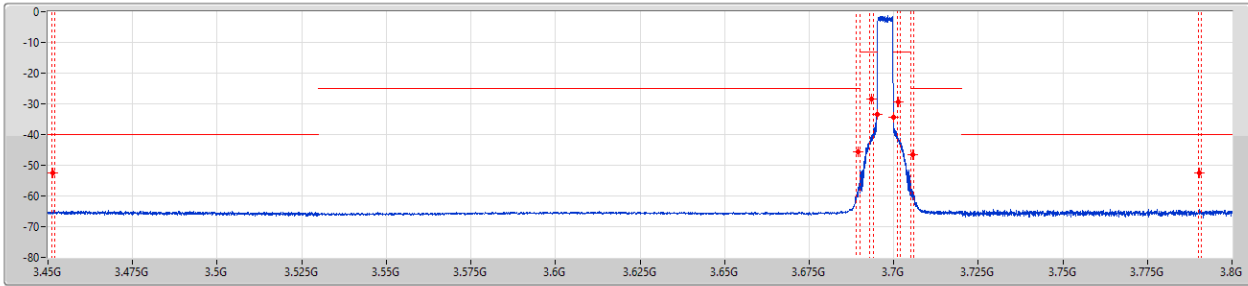

F-Start(Hz)	F-Stop(Hz)	RBW(Hz)	VBW(Hz)	Detector	Freq(Hz)	Level(dBm)	Limit(dBm)	Margin(dB)	Remark	Ref.Limit(dB)
3.45G	3.53G	50k	200k	RMS	3.4515G	-52.65	-40.00	-12.65	MBW 1M	-
3.53G	3.69G	50k	200k	RMS	3.6895G	-45.75	-25.00	-20.75	MBW 1M	-
3.69G	3.694G	50k	200k	RMS	3.6935G	-28.46	-13.00	-15.46	MBW 1M	-
3.694G	3.695G	50k	200k	RMS	3.695G	-33.58	-13.00	-20.58	-	-
3.7G	3.701G	50k	200k	RMS	3.70001G	-34.34	-13.00	-21.34	-	-
3.701G	3.705G	50k	200k	RMS	3.7015G	-29.24	-13.00	-16.24	MBW 1M	-
3.705G	3.72G	50k	200k	RMS	3.7055G	-46.55	-25.00	-21.55	MBW 1M	-
3.72G	3.8G	50k	200k	RMS	3.7905G	-52.53	-40.00	-12.53	MBW 1M	-

Band 48\_LTE\_5MHz\_Nss1,256QAM\_1TX  
3697.5MHz\_256QAM\_RB 1,#RB R

CSE-TX-Sum

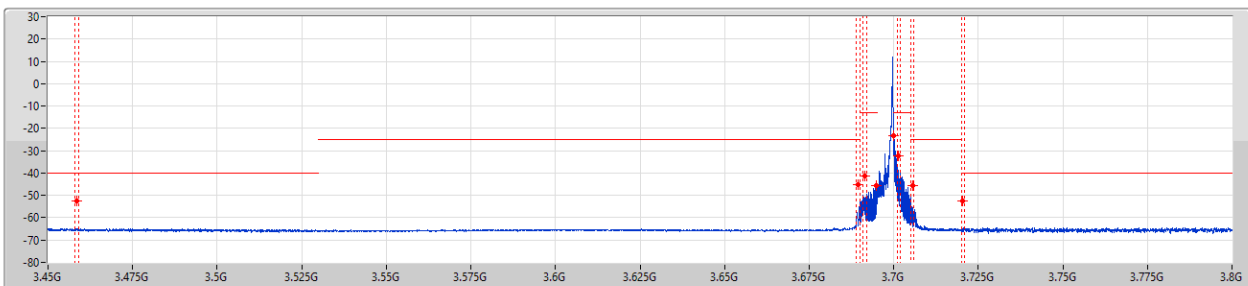

F-Start(Hz)	F-Stop(Hz)	RBW(Hz)	VBW(Hz)	Detector	Freq(Hz)	Level(dBm)	Limit(dBm)	Margin(dB)	Remark	Ref.Limit(dB)
3.45G	3.53G	50k	200k	RMS	3.4585G	-52.57	-40.00	-12.57	MBW 1M	-
3.53G	3.69G	50k	200k	RMS	3.6895G	-45.26	-25.00	-20.26	MBW 1M	-
3.69G	3.694G	50k	200k	RMS	3.6915G	-41.51	-13.00	-28.51	MBW 1M	-
3.694G	3.695G	50k	200k	RMS	3.69486G	-45.48	-13.00	-32.48	-	-
3.7G	3.701G	50k	200k	RMS	3.70002G	-23.18	-13.00	-10.18	-	-
3.701G	3.705G	50k	200k	RMS	3.7015G	-32.16	-13.00	-19.16	MBW 1M	-
3.705G	3.72G	50k	200k	RMS	3.7055G	-45.51	-25.00	-20.51	MBW 1M	-
3.72G	3.8G	50k	200k	RMS	3.7205G	-52.47	-40.00	-12.47	MBW 1M	-

