

# FCC TEST REPORT

## FCC ID:2A5VZ-F10

**Applicant:** Shenzhen Youxin International Technology Co. , Ltd.  
Address: Room 02,14th floor,building a,Jiahe Huaqiang building,3006ShennanMiddleRoad, Huahang community Huaqiang North Street, FutanDistrict,Shenzhen China

**Manufacturer:** Shenzhen Youxin International Technology Co. , Ltd.  
Address: Room 02,14th floor,building a,Jiahe Huaqiang building,3006ShennanMiddleRoad, Huahang community Huaqiang North Street, FutanDistrict,Shenzhen China

**EUT:** Business Wireless Headphones

Trade Mark: N/A

Model Number: F10  
T9, F33, F9, F11, F22, F99, B28, DX-09, F88, F10 PRO

Date of Receipt: Jun. 06, 2025

Test Date: Jun. 06, 2025 to Jun. 13, 2025

Date of Report: Jun. 13, 2025

Prepared By: Shenzhen DL Testing Technology Co., Ltd.  
Address: 101-201, Building C, Shuanghuan, No.8, Baoqing Roa Baolong Industrial Zone, Baolong Street, Longgang Shenzhen, Guangdong, China

Applicable Standards: FCC CFR Title 47 Part 15 Subpart C Section 15.247  
ANSI C63.10:2013

Test Result: Pass

Report Number: DLE-250617008R

Prepared (Test Engineer): Dimon Tan

Reviewer (Supervisor): Jack Bu

Approved (Manager): Jade Yang



*This test report is based on a single evaluation of one sample of above mentioned products. It is not permitted to be duplicated in extracts without written approval of Shenzhen DL Testing Technology Co., Ltd.*

## Table of Contents

	Page
<b>1. VERSION</b> .....	<b>4</b>
<b>2. TEST SUMMARY</b> .....	<b>5</b>
2.1 TEST FACILITY .....	6
2.2 MEASUREMENT UNCERTAINTY .....	6
<b>3. GENERAL INFORMATION</b> .....	<b>7</b>
3.1 GENERAL DESCRIPTION OF EUT .....	7
3.2 TEST SETUP CONFIGURATION .....	9
3.3 SUPPORT EQUIPMENT .....	9
3.4 TEST MODE .....	9
<b>4. EMC EMISSION TEST</b> .....	<b>12</b>
4.1 CONDUCTED EMISSIONS .....	12
4.1.1 POWER LINE CONDUCTED EMISSION LIMITS .....	12
4.1.2 TEST PROCEDURE .....	12
4.1.3 DEVIATION FROM TEST STANDARD .....	12
4.1.4 TEST SETUP .....	13
4.1.5 EUT OPERATING CONDITIONS .....	13
4.1.6 TEST RESULT .....	14
4.2 RADIATED EMISSIONS .....	16
4.2.1 RADIATED EMISSION LIMITS .....	16
4.2.2 TEST PROCEDURE .....	16
4.2.3 DEVIATION FROM TEST STANDARD .....	17
4.2.4 TEST SETUP .....	17
4.2.5 EUT OPERATING CONDITIONS .....	18
4.2.6 TEST RESULTS .....	18
<b>5. RADIATED BAND EMISSION MEASUREMENT</b> .....	<b>27</b>
5.1 TEST REQUIREMENT .....	27
5.2 TEST PROCEDURE .....	27
5.3 DEVIATION FROM TEST STANDARD .....	28
5.4 TEST SETUP .....	28
5.5 EUT OPERATING CONDITIONS .....	28
5.6 TEST RESULT .....	29
<b>6. CONDUCTED BAND EDGE AND SPURIOUS EMISSION</b> .....	<b>31</b>
6.1 LIMIT .....	31
6.2 TEST SETUP .....	31
6.3 TEST PROCEDURE .....	31
6.4 DEVIATION FROM STANDARD .....	31

6.5 TEST RESULT .....	32
<b>7. 20DB OCCUPIED BANDWIDTH .....</b>	<b>38</b>
7.1 TEST SETUP .....	38
7.2 LIMIT .....	38
7.3 TEST PROCEDURE .....	38
7.4 DEVIATION FROM STANDARD .....	38
7.5 TEST RESULT .....	39
<b>8. MAXIMUM PEAK OUTPUT POWER .....</b>	<b>43</b>
8.1 BLOCK DIAGRAM OF TEST SETUP .....	43
8.2 LIMIT .....	43
8.3 TEST PROCEDURE .....	43
8.4 DEVIATION FROM STANDARD .....	43
8.5 TEST RESULT .....	44
<b>9. HOPPING CHANNEL SEPARATION .....</b>	<b>48</b>
9.1 TEST SETUP .....	48
9.2 TEST PROCEDURE .....	48
9.3 DEVIATION FROM STANDARD .....	48
9.4 TEST RESULT .....	49
<b>10. NUMBER OF HOPPING FREQUENCY .....</b>	<b>53</b>
10.1 TEST SETUP .....	53
10.2 TEST PROCEDURE .....	53
10.3 DEVIATION FROM STANDARD .....	53
10.4 TEST RESULT .....	54
<b>11. DWELL TIME .....</b>	<b>56</b>
11.1 TEST SETUP .....	56
11.2 TEST PROCEDURE .....	56
11.3 DEVIATION FROM STANDARD .....	56
11.4 TEST RESULT .....	57
<b>12. ANTENNA REQUIREMENT .....</b>	<b>61</b>
<b>13. TEST SETUP PHOTO .....</b>	<b>62</b>
<b>14. EUT CONSTRUCTIONAL DETAILS .....</b>	<b>62</b>

**1. VERSION**

<b>Report No.</b>	<b>Version</b>	<b>Description</b>	<b>Approved</b>
DLE-250617008R	Rev.01	Initial issue of report	Jun. 13, 2025

**2. TEST SUMMARY**

Test procedures according to the technical standards:

FCC Part15 (15.247) , Subpart C			
Standard Section	Test Item	Result	Remark
15.203/15.247 (c)	Antenna Requirement	PASS	
15.207	AC Power Line Conducted Emission	PASS	
15.247 (b)(1)	Conducted Peak Output Power	PASS	
15.247 (a)(1)	20dB Occupied Bandwidth	PASS	
15.247 (a)(1)	Carrier Frequencies Separation	PASS	
15.247 (a)(1)(iii)	Hopping Channel Number	PASS	
15.247 (a)(1)(iii)	Dwell Time	PASS	
15.205/15.209 15.247(d)	Radiated Emission and Restricted Band	PASS	
15.247(d)	Conducted Unwanted Emissions and Band Edge	PASS	

**NOTE:**

(1) "N/A" denotes test is not applicable in this Test Report

## 2.1 TEST FACILITY

Shenzhen DL Testing Technology Co., Ltd.

Add. : 101-201, Building C, Shuanghuan, No.8, Baoqing Roa Baolong Industrial Zone, Baolong Street, Longgang Shenzhen, Guangdong, China

FCC Test Firm Registration Number: 854456

Designation Number: CN1307

IC Registered No.: 27485

CAB identifier: CN0118

## 2.2 MEASUREMENT UNCERTAINTY

The reported uncertainty of measurement  $y \pm U$ , where expanded uncertainty  $U$  is based on a standard uncertainty multiplied by a coverage factor of  $k=2$ , providing a level of confidence of approximately 95 %.

No.	Item	Uncertainty
1	3m chamber Radiated spurious emission(9KHz-30MHz)	U=4.5dB
2	3m chamber Radiated spurious emission(30MHz-1GHz)	U=4.8dB
3	3m chamber Radiated spurious emission(1GHz-6GHz)	U=4.9dB
4	3m chamber Radiated spurious emission(6GHz-40GHz)	U=5.0dB
5	Conducted disturbance	U=3.2dB
6	RF Band Edge	U=1.68dB
7	RF power conducted	U=1.86dB
8	RF conducted Spurious Emission	U=2.2dB
9	RF Occupied Bandwidth	U=1.8MHz
10	RF Power Spectral Density	U=1.75dB
11	Humidity uncertainty	U=5.3%
12	Temperature uncertainty	U=0.59°C
13	RF Dwell Time	U=0.02ms

### 3. GENERAL INFORMATION

#### 3.1 GENERAL DESCRIPTION OF EUT

Product Name:	Business Wireless Headphones
Model No.:	F10
Serial No.:	T9, F33, F9, F11, F22, F99, B28, DX-09, F88, F10 PRO
Model Different.:	All the model are the same circuit and RF module, Only the model name different.
Hardware Version:	V1.0
Software Version:	V1.1
Sample(s) Status:	Engineer sample
Channel Numbers:	79 Channels
Channel Spacing:	1MHz
Operation Frequency:	2402MHz~2480MHz
Bluetooth Version:	V6.0
Modulation Technology:	GFSK, $\pi/4$ -DQPSK, 8-DPSK
Antenna Type:	PCB Antenna
Antenna Gain:	0.93dBi
Power Supply:	Input: 5V---0.5A
Battery Capacity:	DC 3.7V, 250mAh, 0.925Wh

Operation Frequency each of channel							
Channel	Frequency	Channel	Frequency	Channel	Frequency	Channel	Frequency
1	2402MHz	21	2422MHz	41	2442MHz	61	2462MHz
2	2403MHz	22	2423MHz	42	2443MHz	62	2463MHz
3	2404MHz	23	2424MHz	43	2444MHz	63	2464MHz
4	2405MHz	24	2425MHz	44	2445MHz	64	2465MHz
5	2406MHz	25	2426MHz	45	2446MHz	65	2466MHz
6	2407MHz	26	2427MHz	46	2447MHz	66	2467MHz
7	2408MHz	27	2428MHz	47	2448MHz	67	2468MHz
8	2409MHz	28	2429MHz	48	2449MHz	68	2469MHz
9	2410MHz	29	2430MHz	49	2450MHz	69	2470MHz
10	2411MHz	30	2431MHz	50	2451MHz	70	2471MHz
11	2412MHz	31	2432MHz	51	2452MHz	71	2472MHz
12	2413MHz	32	2433MHz	52	2453MHz	72	2473MHz
13	2414MHz	33	2434MHz	53	2454MHz	73	2474MHz
14	2415MHz	34	2435MHz	54	2455MHz	74	2475MHz
15	2416MHz	35	2436MHz	55	2456MHz	75	2476MHz
16	2417MHz	36	2437MHz	56	2457MHz	76	2477MHz
17	2418MHz	37	2438MHz	57	2458MHz	77	2478MHz
18	2419MHz	38	2439MHz	58	2459MHz	78	2479MHz
19	2420MHz	39	2440MHz	59	2460MHz	79	2480MHz
20	2421MHz	40	2441MHz	60	2461MHz		

**Note:**

In section 15.31(m), regards to the operating frequency range over 10 MHz, the Lowest frequency, the middle frequency, and the highest frequency of channel were selected to perform the test, and the selected channel see below:

Test channel	Frequency
The lowest channel	2402MHz
The middle channel	2441MHz
The Highest channel	2480MHz



### 3.2 TEST SETUP CONFIGURATION

#### Conducted Emission

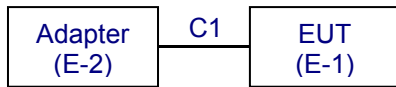

#### Radiated Emission

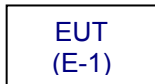

#### Conducted Spurious



### 3.3 SUPPORT EQUIPMENT

The EUT has been tested as an independent unit together with other necessary accessories or support units. The following support units or accessories were used to form a representative test configuration during the tests.

Item	Equipment	Mfr/Brand	Model/Type No.	Series No.	Note
E-1	Business Wireless Headphones	N/A	F10	N/A	EUT
E-2	AC/DC Adapter	SAMSUNG	EP-T4510	N/A	Auxiliary

Item	Shielded Type	Ferrite Core	Length	Note
C1	NO	NO	0.8M	Type-C USB Cable

**Note:**

- (1) The support equipment was authorized by Declaration of Confirmation.
- (2) For detachable type I/O cable should be specified the length in cm in 『Length』 column.

### 3.4 TEST MODE

Transmitting mode	Keep the EUT in continuously transmitting mode
Charging Mode:	Keep the EUT in Charging mode.
Remark: During the test, the test voltage was tuned from 85% to 115% of the nominal rated supply voltage, and found that the worst case was under the nominal rated supply condition. So the report just shows that condition's data. For battery operated equipment, the equipment tests shall be performed using a new battery.	

Test Software	BT_Tool
Power level setup	7dBm

### 3.5 EQUIPMENTS LIST FOR ALL TEST ITEMS

#### Conduction Emissions Test

Item	Kind of Equipment	Manufacturer	Type No.	Serial No.	Firmware Version	Last calibration	Calibrated until
1	LISN	R&S	ENV216	101471	N/A	Sep. 30, 2024	Sep. 29, 2025
2	LISN	CYBERTEK	EM5040A	E1850400149	N/A	Sep. 30, 2024	Sep. 29, 2025
3	Test Cable	N/A	C-01	N/A	N/A	Sep. 30, 2024	Sep. 29, 2025
4	EMI Test Receiver	R&S	ESCI3	101393	4.42 SP3	Sep. 29, 2024	Sep. 28, 2025
5	EMC Software	Frad	EZ-EMC	Ver.EMC-CON 3A1.1	N/A	\	\

#### Radiation Emissions & Radiation Spurious Emissions Test

Item	Equipment	Manufacturer	Type No.	Serial No.	Firmware Version	Last calibration	Calibrated until
1	Spectrum Analyzer (9kHz-26.5GHz)	KEYSIGHT	N9020A	MY55370835	A.17.05	Sep. 29, 2024	Sep. 28, 2025
2	Spectrum Analyzer (10kHz-39.9GHz)	R&S	FSV40-N	100363	1.71 SP2	Sep. 30, 2024	Sep. 29, 2025
3	EMI Test Receiver (9kHz-7GHz)	R&S	ESCI7	100969	4.32	Sep. 29, 2024	Sep. 28, 2025
4	Bilog Antenna (30MHz-1500MHz)	Schwarzbeck	VULB9168	00877	N/A	Sep. 30, 2024	Sep. 29, 2025
5	Horn Antenna (1GHz-18GHz)	Agilent	AH-118	071145	N/A	Sep. 30, 2024	Sep. 29, 2025
6	Horn Antenna (15GHz-40GHz)	A.H.System	SAS-574	588	N/A	Sep. 30, 2024	Sep. 29, 2025
7	Loop Antenna	TESEQ	HLA6121	58357	N/A	Oct. 11, 2024	Oct. 10, 2025
8	Amplifier (30-1000MHz)	EM Electronics	EM330 Amplifier	60747	N/A	Sep. 29, 2024	Sep. 28, 2025
9	Amplifier (1GHz-26.5GHz)	HuiPu	8449B	3008A00315	N/A	Sep. 29, 2024	Sep. 28, 2025
10	Amplifier (500MHz-40GHz)	QuanJuDa	DLE-161	097	N/A	Sep. 30, 2024	Sep. 29, 2025
11	Test Cable	N/A	R-01	N/A	N/A	Sep. 30, 2024	Sep. 29, 2025
12	Test Cable	N/A	R-02	N/A	N/A	Sep. 30, 2024	Sep. 29, 2025
13	Test Cable	N/A	R-03	N/A	N/A	Sep. 30, 2024	Sep. 29, 2025
14	D.C. Power Supply	LongWei	TPR-6405D	GQ7516	N/A	Sep. 29, 2024	Sep. 28, 2025
15	EMC Software	Frad	EZ-EMC	Ver.EMC-CO N 3A1.1	N/A	\	\
16	Turntable	MF	MF-7802BS	N/A	N/A	\	\
17	Antenna tower	MF	MF-7802BS	N/A	N/A	\	\

RF Conducted Test

Item	Equipment	Manufacturer	Type No.	Serial No.	Firmware Version	Last calibration	Calibrated until
1	Spectrum Analyzer (9kHz-26.5GHz)	KEYSIGHT	N9020A	MY55370835	A.17.05	Sep. 29, 2024	Sep. 28, 2025
2	Spectrum Analyzer (10kHz-39.9GHz)	R&S	FSV40-N	100363	1.71 SP2	Sep. 30, 2024	Sep. 29, 2025
3	Test Cable	N/A	RF-01	N/A	N/A	Sep. 30, 2024	Sep. 29, 2025
4	Test Cable	N/A	RF-02	N/A	N/A	Sep. 30, 2024	Sep. 29, 2025
5	Test Cable	N/A	RF-03	N/A	N/A	Sep. 30, 2024	Sep. 29, 2025
6	ESG Signal Generator	Agilent	E4421B	GB40051203	B.03.84	Sep. 29, 2024	Sep. 28, 2025
7	Signal Generator	Agilent	N5182A	MY47420215	A.01.87	Sep. 29, 2024	Sep. 28, 2025
8	Magnetic Field Probe Tester	Narda	ELT-400	0-0344	N/A	Sep. 29, 2024	Sep. 28, 2025
9	Van der Hoofden measuring head	Schwarzbeck Mess-elektronik	VDHH 9502	9502-039	N/A	Sep. 30, 2024	Sep. 29, 2025
10	Wideband Radio Communication Test	R&S	CMW500	106504	V 3.7.22	Sep. 30, 2024	Sep. 29, 2025
11	MWRF Power Meter Test system	MW	MW100-RF CB	10371	N/A	Sep. 29, 2024	Sep. 28, 2025
12	Power Meter	KEYSIGHT	N1912AP	926431	A.05.00	Sep. 29, 2024	Sep. 28, 2025
13	D.C. Power Supply	LongWei	TPR-6405D	GQ7516	N/A	Sep. 29, 2024	Sep. 28, 2025
14	RF Software	MW	MTS8310	V2.0.0.0	N/A	\	\

#### 4. EMC EMISSION TEST

##### 4.1 CONDUCTED EMISSIONS

Test Requirement:	FCC Part15 C Section 15.207
Test Method:	ANSI C63.10:2013
Test Frequency Range:	150KHz to 30MHz
Receiver setup:	RBW=9KHz, VBW=30KHz, Sweep time=auto

##### 4.1.1 POWER LINE CONDUCTED EMISSION LIMITS

FREQUENCY (MHz)	Limit (dBuV)		Standard
	Quasi-peak	Average	
0.15 -0.5	66 - 56 *	56 - 46 *	FCC
0.50 -5.0	56.00	46.00	FCC
5.0 -30.0	60.00	50.00	FCC

Note:

(1) \*Decreases with the logarithm of the frequency.

##### 4.1.2 TEST PROCEDURE

- a. The EUT was placed 0.8 meters from the horizontal ground plane with EUT being connected to the power mains through a line impedance stabilization network (LISN). All other support equipments powered from additional LISN(s). The LISN provide 50 Ohm/ 50uH of coupling impedance for the measuring instrument.
- b. Interconnecting cables that hang closer than 40 cm to the ground plane shall be folded back and forth in the center forming a bundle 30 to 40 cm long.
- c. I/O cables that are not connected to a peripheral shall be bundled in the center. The end of the cable may be terminated, if required, using the correct terminating impedance. The overall length shall not exceed 1 m.
- d. LISN at least 80 cm from nearest part of EUT chassis.
- e. For the actual test configuration, please refer to the related Item –EUT Test Photos.

##### 4.1.3 DEVIATION FROM TEST STANDARD

No deviation

#### 4.1.4 TEST SETUP

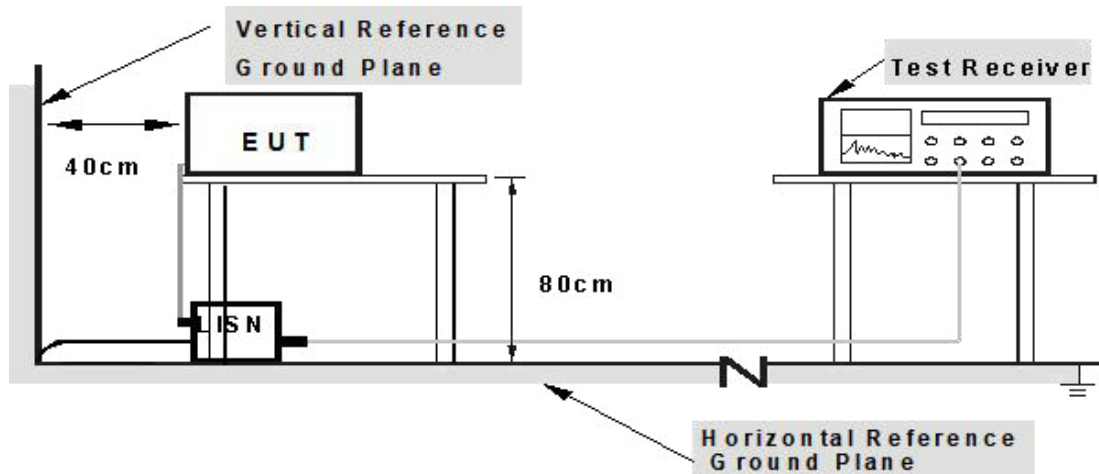

- Note: 1.Support units were connected to second LISN.  
2.Both of LISNs (AMN) are 80 cm from EUT and at least 80  
from other units and other metal planes**

#### 4.1.5 EUT OPERATING CONDITIONS

The EUT was configured for testing in a typical fashion (as a customer would normally use it). The EUT has been programmed to Charging during test. This operating condition was tested and used to collect the included data.

#### 4.1.6 TEST RESULT

Temperature:	26°C	Relative Humidity:	54%
Pressure:	101 kPa	Polarization:	L
Test Voltage:	AC 120V/60Hz	Test Mode:	Charging

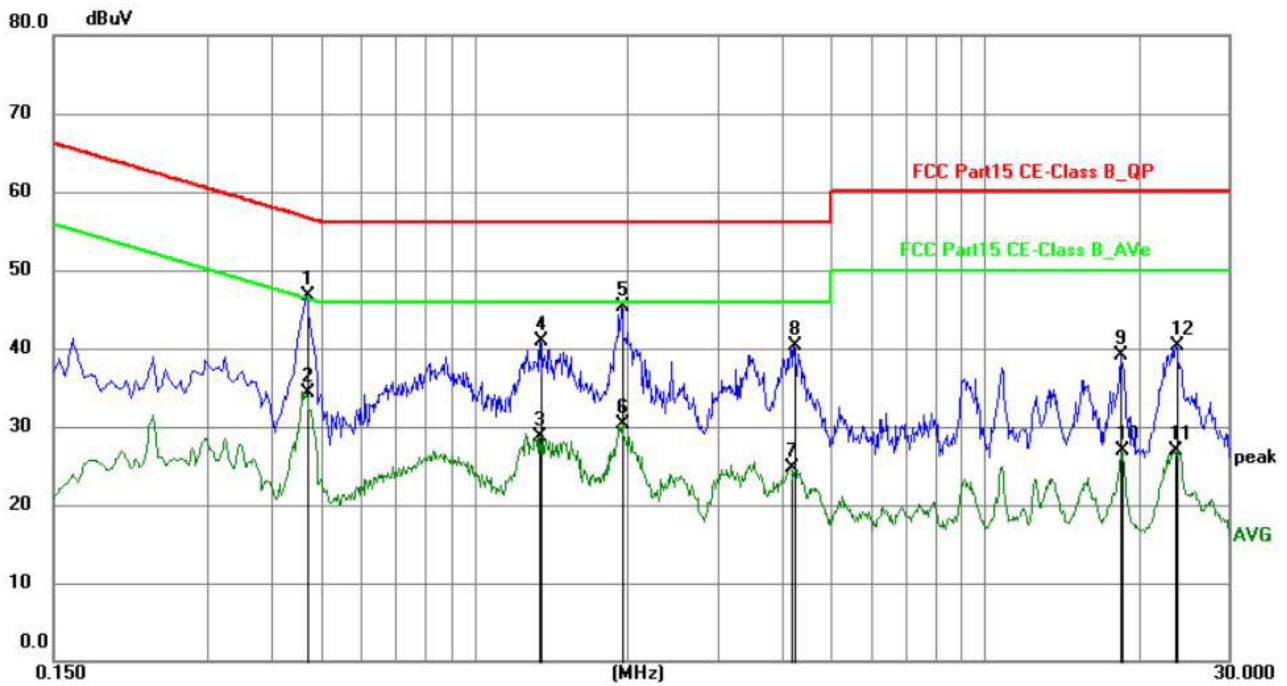

No.	Frequency (MHz)	Reading (dBuV)	Factor (dB)	Level (dBuV)	Limit (dBuV)	Margin (dB)	Detector	P/F	Remark
1	0.4695	26.32	20.31	46.63	56.52	-9.89	QP	P	
2	0.4695	14.08	20.31	34.39	46.52	-12.13	AVG	P	
3	1.3424	8.32	20.31	28.63	46.00	-17.37	AVG	P	
4	1.3469	20.65	20.31	40.96	56.00	-15.04	QP	P	
5	1.9409	24.94	20.31	45.25	56.00	-10.75	QP	P	
6	1.9500	9.97	20.31	30.28	46.00	-15.72	AVG	P	
7	4.1774	4.35	20.35	24.70	46.00	-21.30	AVG	P	
8	4.2270	20.02	20.35	40.37	56.00	-15.63	QP	P	
9	18.5190	18.61	20.50	39.11	60.00	-20.89	QP	P	
10	18.6135	6.32	20.50	26.82	50.00	-23.18	AVG	P	
11	23.6310	6.36	20.60	26.96	50.00	-23.04	AVG	P	
12	23.7255	19.80	20.60	40.40	60.00	-19.60	QP	P	

**Notes:**

1. An initial pre-scan was performed on the line and neutral lines with peak detector.
2. Quasi - Peak and Average measurement were performed at the frequencies with maximized peak emission.
3. Final Level = Reading level + Correct Factor.
4. Correct Factor = Lisn factor+ Cable loss factor + limiter factor.
5. Margin = Measurement Level-Limit.
6. The EUT cannot be charged and operated at the same time.

Temperature:	26°C	Relative Humidity:	54%
Pressure:	101 kPa	Polarization:	N
Test Voltage:	AC 120V/60Hz	Test Mode:	Charging

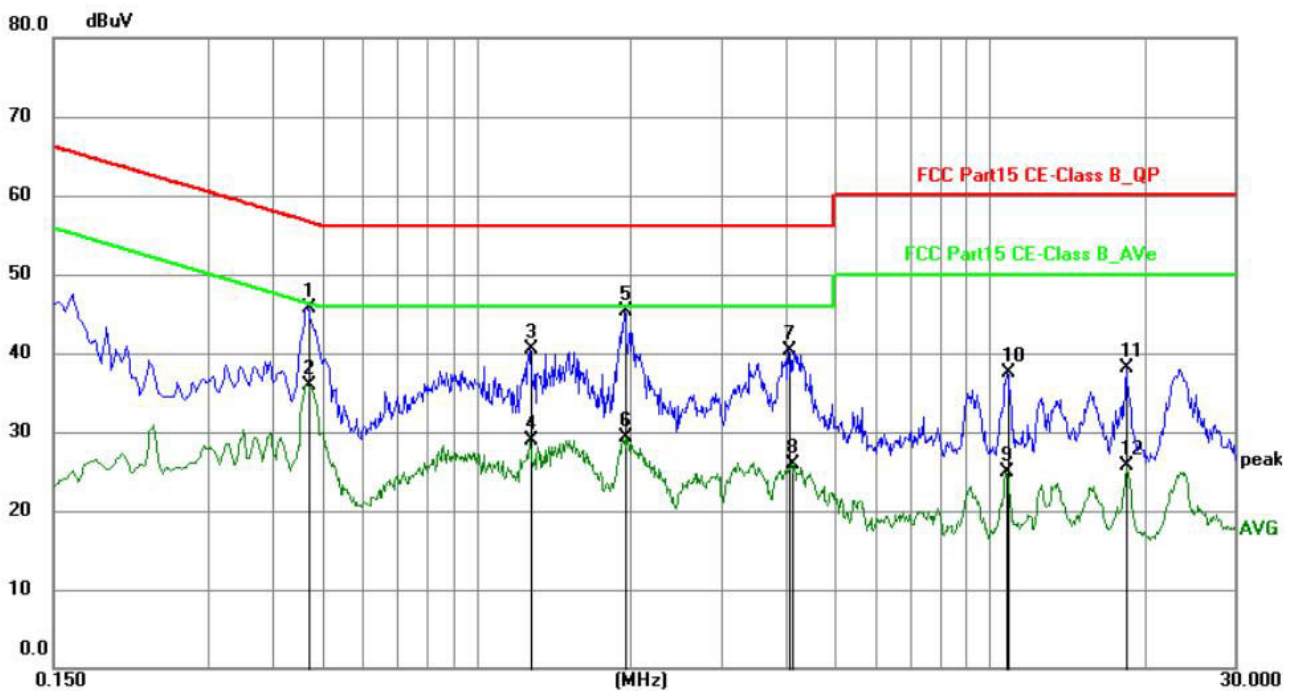

No.	Frequency (MHz)	Reading (dBuV)	Factor (dB)	Level (dBuV)	Limit (dBuV)	Margin (dB)	Detector	P/F	Remark
1	0.4695	25.45	20.31	45.76	56.52	-10.76	QP	P	
2	0.4695	15.52	20.31	35.83	46.52	-10.69	AVG	P	
3	1.2703	20.10	20.31	40.41	56.00	-15.59	QP	P	
4	1.2703	8.67	20.31	28.98	46.00	-17.02	AVG	P	
5	1.9454	24.96	20.31	45.27	56.00	-10.73	QP	P	
6	1.9544	9.02	20.31	29.33	46.00	-16.67	AVG	P	
7	4.0605	19.99	20.33	40.32	56.00	-15.68	QP	P	
8	4.1280	5.66	20.34	26.00	46.00	-20.00	AVG	P	
9	10.7700	4.44	20.47	24.91	50.00	-25.09	AVG	P	
10	10.8465	16.95	20.47	37.42	60.00	-22.58	QP	P	
11	18.5100	17.50	20.52	38.02	60.00	-21.98	QP	P	
12	18.5100	5.14	20.52	25.66	50.00	-24.34	AVG	P	

Notes:

- 1.An initial pre-scan was performed on the line and neutral lines with peak detector.
- 2.Quasi - Peak and Average measurement were performed at the frequencies with maximized peak emission.
- 3.Final Level = Reading level + Correct Factor.
- 4.Correct Factor = Lisen factor+ Cable loss factor + limiter factor.
- 5.Margin = Measurement Level-Limit.
- 6.The EUT cannot be charged and operated at the same time.

#### 4.2 RADIATED EMISSIONS

Test Requirement:	FCC Part15 C Section 15.209				
Test Method:	ANSI C63.10:2013				
Test Frequency Range:	9kHz to 25GHz				
Test site:	Measurement Distance: 3m				
Receiver setup:	Frequency	Detector	RBW	VBW	Value
	9KHz-150KHz	Quasi-peak	200Hz	MX5Hz	Quasi-peak
	150KHz-30MHz	Quasi-peak	9KHz	30KHz	Quasi-peak
	30MHz-1GHz	Quasi-peak	120KHz	300KHz	Quasi-peak
	Above 1GHz	Peak	1MHz	3MHz	Peak
Peak		1MHz	10Hz	Average	

##### 4.2.1 RADIATED EMISSION LIMITS

Frequencies (MHz)	Field Strength (micorvolts/meter)	Measurement Distance (meters)
0.009~0.490	2400/F(KHz)	300
0.490~1.705	24000/F(KHz)	30
1.705~30.0	30	30
30~88	100	3
88~216	150	3
216~960	200	3
Above 960	500	3

##### LIMITS OF RADIATED EMISSION MEASUREMENT

FREQUENCY (MHz)	Limit (dBuV/m) (at 3M)	
	PEAK	AVERAGE
Above 1000	74	54

Notes:

- (1) The limit for radiated test was performed according to FCC PART 15C.
- (2) The tighter limit applies at the band edges.
- (3) Emission level (dBuV/m)=20log Emission level (uV/m).

##### 4.2.2 TEST PROCEDURE

Below 1GHz test procedure as below:

- a. The EUT was placed on the top of a rotating table 0.8 meters above the ground at a 3 meter semi-anechoic chamber. The table was rotated 360 degrees to determine the position of the highest radiation.
- b. The EUT was set 3 meters away from the interference-receiving antenna, which was mounted on the top of a variable-height antenna tower.
- c. The antenna height is varied from one meter to four meters above the ground to determine the maximum value of the field strength. Both horizontal and vertical polarizations of the antenna are set to make the measurement.
- d. For each suspected emission, the EUT was arranged to its worst case and then the antenna was tuned to heights from 1 meter to 4 meters (for the test frequency of below 30MHz, the antenna was tuned to heights 1 meter) and the rotatable table was turned from 0 degrees to 360 degrees to find the maximum reading.



- e. The test-receiver system was set to Peak Detect Function and Specified Bandwidth with Maximum Hold Mode.
- f. If the emission level of the EUT in peak mode was 10dB lower than the limit specified, then testing could be stopped and the peak values of the EUT would be reported. Otherwise the emissions that did not have 10dB margin would be re-tested one by one using peak, quasi-peak or average method as specified and then reported in a data sheet.

Above 1GHz test procedure as below:

- g. Different between above is the test site, change from Semi- Anechoic Chamber to fully Anechoic Chamber and change form table 0.8 metre to 1.5 metre( Above 18GHz the distance is 1 meter and table is 1.5 metre).
- h. Test the EUT in the lowest channel ,the middle channel ,the Highest channel

Note:

Both horizontal and vertical antenna polarities were tested and performed pretest to three orthogonal axis. The worst case emissions were reported

#### 4.2.3 DEVIATION FROM TEST STANDARD

No deviation

#### 4.2.4 TEST SETUP

(A) Radiated Emission Test-Up Frequency Below 30MHz

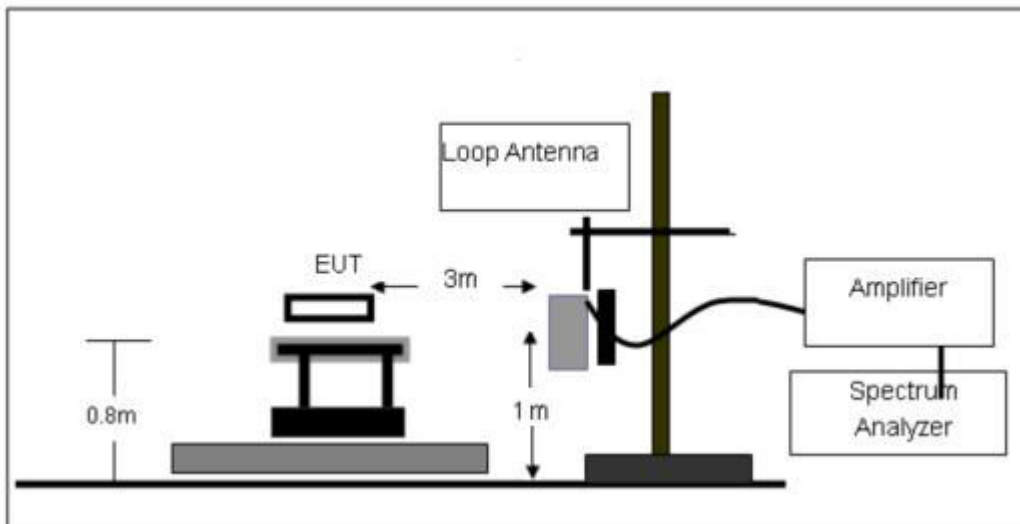

(B) Radiated Emission Test-Up Frequency 30MHz~1GHz

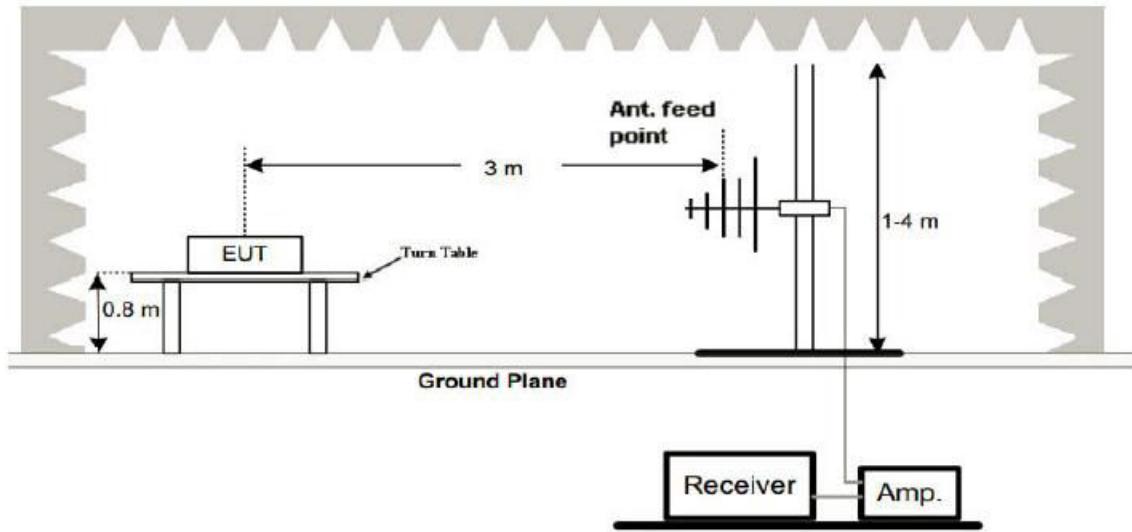

(C) Radiated Emission Test-Up Frequency Above 1GHz

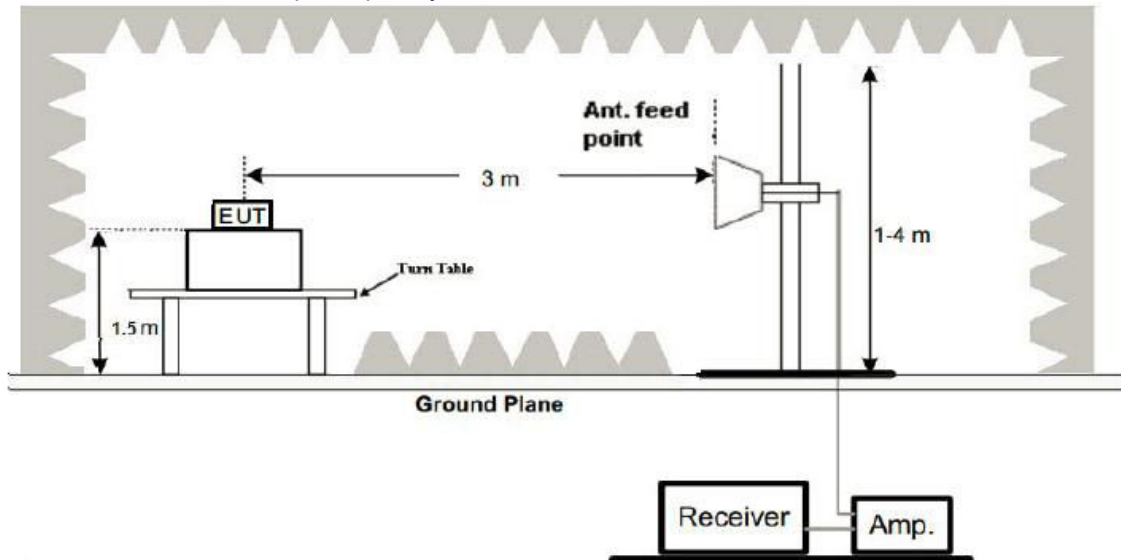

4.2.5 EUT OPERATING CONDITIONS

The EUT was configured for testing in a typical fashion (as a customer would normally use it). The EUT has been programmed to continuously transmit during test. This operating condition was tested and used to collect the included data.

4.2.6 TEST RESULTS

a. Between 9KHz – 30MHz

The emission from 9 kHz to 30MHz was pre-tested and found the result was 20dB lower than the limit, and according to 15.31(o) & RSS-Gen 6.13, the test result no need to reported.

b. Between 30MHz – 1GHz

Temperature:	26°C	Relative Humidity:	54%
Pressure:	101 kPa	Polarization:	Horizontal
Test Voltage:	DC 3.7V	Test Mode :	GFSK 1-DH1 - 2402MHz

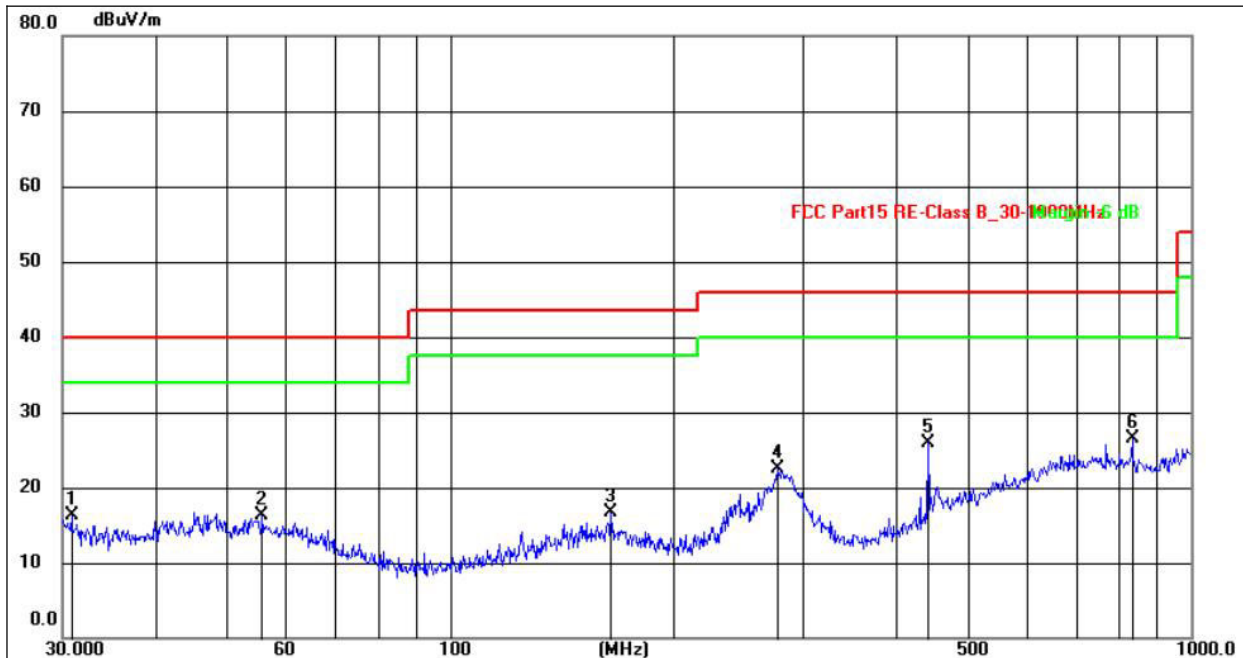

No.	Frequency (MHz)	Reading (dBuV)	Factor (dB/m)	Level (dBuV/m)	Limit (dBuV/m)	Margin (dB)	Detector
1	30.8534	30.46	-14.25	16.21	40.00	-23.79	QP
2	55.8046	30.34	-14.05	16.29	40.00	-23.71	QP
3	164.9072	33.01	-16.36	16.65	43.50	-26.85	QP
4	277.0935	36.55	-14.12	22.43	46.00	-23.57	QP
5	441.7425	39.80	-13.96	25.84	46.00	-20.16	QP
6	833.3170	33.22	-6.66	26.56	46.00	-19.44	QP

Remarks:

1. An initial pre-scan was performed on the peak detector.
2. Quasi-Peak measurement were performed at the frequencies with maximized peak emission.
3. The emission levels of other frequencies are very lower than the limit and not show in test report.
4. Final Level = Reading level + Correct Factor.
5. Correct Factor = Antenna factor+ Cable loss factor - Amplifier factor.
6. Margin= Measurement Level-Limit.
7. The test data shows only the worst case GFSK 1-DH1 - 2402MHz.

Temperature:	26°C	Relative Humidity:	54%
Pressure:	101kPa	Polarization:	Vertical
Test Voltage:	DC 3.7V	Test Mode :	GFSK 1-DH1 - 2402MHz

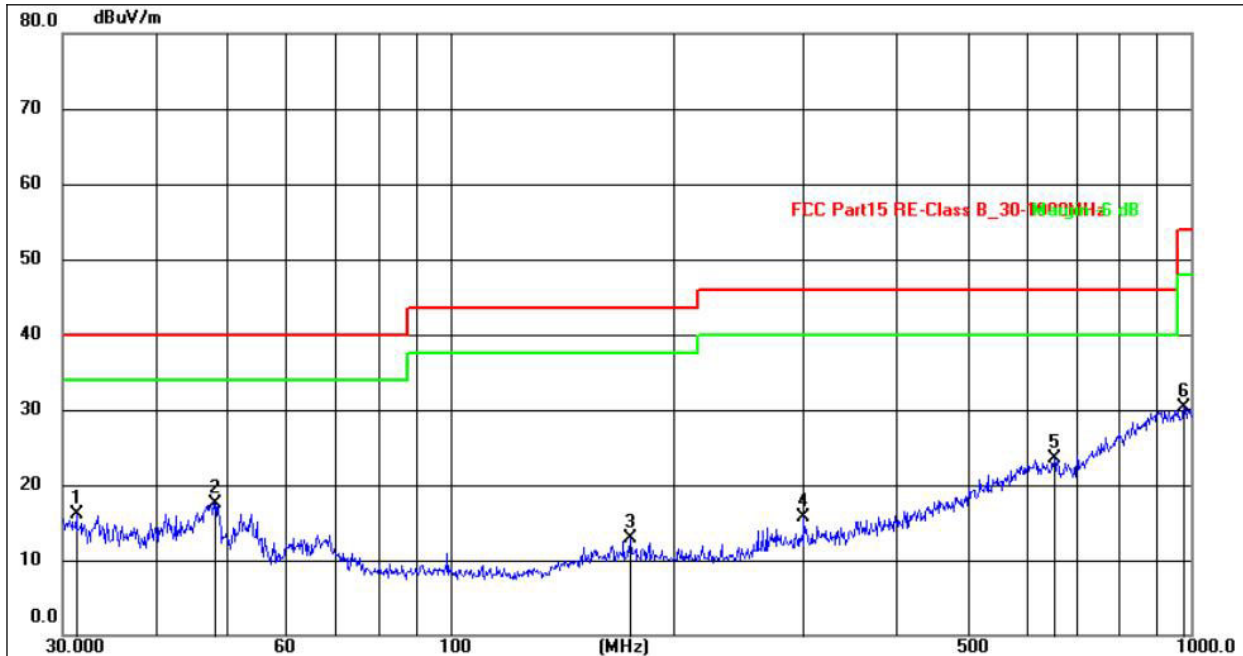

No.	Frequency (MHz)	Reading (dBuV)	Factor (dB/m)	Level (dBuV/m)	Limit (dBuV/m)	Margin (dB)	Detector
1	31.2892	34.23	-18.12	16.11	40.00	-23.89	QP
2	48.1625	34.65	-17.11	17.54	40.00	-22.46	QP
3	175.0365	32.57	-19.67	12.90	43.50	-30.60	QP
4	300.3672	33.64	-17.89	15.75	46.00	-30.25	QP
5	654.2318	30.94	-7.36	23.58	46.00	-22.42	QP
6	979.1802	30.39	-0.02	30.37	54.00	-23.63	QP

Remarks:

1. An initial pre-scan was performed on the peak detector.
2. Quasi-Peak measurements were performed at the frequencies with maximized peak emission.
3. The emission levels of other frequencies are very lower than the limit and not shown in the test report.
4. Final Level = Reading level + Correct Factor.
5. Correct Factor = Antenna factor + Cable loss factor - Amplifier factor.
6. Margin = Measurement Level - Limit.
7. The test data shows only the worst case GFSK 1-DH1 - 2402MHz.

1GHz~25GHz

GFSK - 1-DH1

Polar (H/V)	Frequency	Meter Reading	Pre-amplifier	Cable Loss	Antenna Factor	Emission Level	Limits	Margin	Detector Type
	(MHz)	(dBuV)	(dB)	(dB)	(dB)	(dBuV/m)	(dBuV/m)	(dB)	
Low Channel:2402MHz									
V	4804.00	54.01	30.55	5.77	24.66	53.89	74.00	-20.11	PK
V	4804.00	43.82	30.55	5.77	24.66	43.70	54.00	-10.30	AV
V	7206.00	52.38	30.33	6.32	24.55	52.92	74.00	-21.08	PK
V	7206.00	43.77	30.33	6.32	24.55	44.31	54.00	-9.69	AV
V	9608.00	54.84	30.85	7.45	24.69	56.13	74.00	-17.87	PK
V	9608.00	43.42	30.85	7.45	24.69	44.71	54.00	-9.29	AV
V	12010.00	52.42	31.02	8.99	25.57	55.96	74.00	-18.04	PK
V	12010.00	43.36	31.02	8.99	25.57	46.90	54.00	-7.10	AV
H	4804.00	54.32	30.55	5.77	24.66	54.20	74.00	-19.80	PK
H	4804.00	43.92	30.55	5.77	24.66	43.80	54.00	-10.20	AV
H	7206.00	54.58	30.33	6.32	24.55	55.12	74.00	-18.88	PK
H	7206.00	43.11	30.33	6.32	24.55	43.65	54.00	-10.35	AV
H	9608.00	52.23	30.85	7.45	24.69	53.52	74.00	-20.48	PK
H	9608.00	43.83	30.85	7.45	24.69	45.12	54.00	-8.88	AV
H	12010.00	52.42	31.02	8.99	25.57	55.96	74.00	-18.04	PK
H	12010.00	43.00	31.02	8.99	25.57	46.54	54.00	-7.46	AV

Polar (H/V)	Frequency	Meter Reading	Pre-amplifier	Cable Loss	Antenna Factor	Emission Level	Limits	Margin	Detector Type
	(MHz)	(dBuV)	(dB)	(dB)	(dB)	(dBuV/m)	(dBuV/m)	(dB)	
Middle Channel:2441MHz									
V	4882.00	53.48	30.55	5.77	24.66	53.36	74.00	-20.64	PK
V	4882.00	43.99	30.55	5.77	24.66	43.87	54.00	-10.13	AV
V	7323.00	54.10	30.33	6.32	24.55	54.64	74.00	-19.36	PK
V	7323.00	43.99	30.33	6.32	24.55	44.53	54.00	-9.47	AV
V	9764.00	50.84	30.85	7.45	24.69	52.13	74.00	-21.87	PK
V	9764.00	43.94	30.85	7.45	24.69	45.23	54.00	-8.77	AV
V	12205.00	50.61	31.02	8.99	25.57	54.15	74.00	-19.85	PK
V	12205.00	43.87	31.02	8.99	25.57	47.41	54.00	-6.59	AV
H	4882.00	53.78	30.55	5.77	24.66	53.66	74.00	-20.34	PK
H	4882.00	43.64	30.55	5.77	24.66	43.52	54.00	-10.48	AV
H	7323.00	53.13	30.33	6.32	24.55	53.67	74.00	-20.33	PK
H	7323.00	43.13	30.33	6.32	24.55	43.67	54.00	-10.33	AV
H	9764.00	53.18	30.85	7.45	24.69	54.47	74.00	-19.53	PK
H	9764.00	43.73	30.85	7.45	24.69	45.02	54.00	-8.98	AV
H	12205.00	53.06	31.02	8.99	25.57	56.60	74.00	-17.40	PK
H	12205.00	43.44	31.02	8.99	25.57	46.98	54.00	-7.02	AV

Polar (H/V)	Frequency	Meter Reading	Pre-ampli fier	Cable Loss	Antenna Factor	Emission Level	Limits	Margin	Detector Type
	(MHz)	(dBuV)	(dB)	(dB)	(dB)	(dBuV/m)	(dBuV/m)	(dB)	
High Channel:2480MHz									
V	4960.00	51.14	30.55	5.77	24.66	51.02	74.00	-22.98	PK
V	4960.00	43.57	30.55	5.77	24.66	43.45	54.00	-10.55	AV
V	7440.00	50.43	30.33	6.32	24.55	50.97	74.00	-23.03	PK
V	7440.00	43.11	30.33	6.32	24.55	43.65	54.00	-10.35	AV
V	9920.00	54.71	30.85	7.45	24.69	56.00	74.00	-18.00	PK
V	9920.00	43.62	30.85	7.45	24.69	44.91	54.00	-9.09	AV
V	12400.00	52.71	31.02	8.99	25.57	56.25	74.00	-17.75	PK
V	12400.00	43.43	31.02	8.99	25.57	46.97	54.00	-7.03	AV
H	4960.00	51.99	30.55	5.77	24.66	51.87	74.00	-22.13	PK
H	4960.00	43.34	30.55	5.77	24.66	43.22	54.00	-10.78	AV
H	7440.00	54.97	30.33	6.32	24.55	55.51	74.00	-18.49	PK
H	7440.00	43.36	30.33	6.32	24.55	43.90	54.00	-10.10	AV
H	9920.00	51.25	30.85	7.45	24.69	52.54	74.00	-21.46	PK
H	9920.00	43.82	30.85	7.45	24.69	45.11	54.00	-8.89	AV
H	12400.00	51.37	31.02	8.99	25.57	54.91	74.00	-19.09	PK
H	12400.00	43.42	31.02	8.99	25.57	46.96	54.00	-7.04	AV

Remark:

1. Emission Level = Meter Reading + Antenna Factor + Cable Loss – Pre-amplifier,  
Margin= Emission Level - Limit
2. If peak below the average limit, the average emission was no test.
3. The amplitude of spurious emissions which are attenuated by more than 20dB below the permissible value has no need to be reported.

$\pi/4$ -DQPSK - 2-DH1

Polar (H/V)	Frequency	Meter Reading	Pre-amplifier	Cable Loss	Antenna Factor	Emission Level	Limits	Margin	Detector Type
	(MHz)	(dBuV)	(dB)	(dB)	(dB)	(dBuV/m)	(dBuV/m)	(dB)	
Low Channel:2402MHz									
V	4804.00	52.13	30.55	5.77	24.66	52.01	74.00	-21.99	PK
V	4804.00	43.70	30.55	5.77	24.66	43.58	54.00	-10.42	AV
V	7206.00	50.75	30.33	6.32	24.55	51.29	74.00	-22.71	PK
V	7206.00	43.33	30.33	6.32	24.55	43.87	54.00	-10.13	AV
V	9608.00	53.06	30.85	7.45	24.69	54.35	74.00	-19.65	PK
V	9608.00	43.59	30.85	7.45	24.69	44.88	54.00	-9.12	AV
V	12010.00	50.71	31.02	8.99	25.57	54.25	74.00	-19.75	PK
V	12010.00	43.24	31.02	8.99	25.57	46.78	54.00	-7.22	AV
H	4804.00	52.79	30.55	5.77	24.66	52.67	74.00	-21.33	PK
H	4804.00	43.70	30.55	5.77	24.66	43.58	54.00	-10.42	AV
H	7206.00	53.67	30.33	6.32	24.55	54.21	74.00	-19.79	PK
H	7206.00	43.78	30.33	6.32	24.55	44.32	54.00	-9.68	AV
H	9608.00	53.95	30.85	7.45	24.69	55.24	74.00	-18.76	PK
H	9608.00	43.62	30.85	7.45	24.69	44.91	54.00	-9.09	AV
H	12010.00	53.84	31.02	8.99	25.57	57.38	74.00	-16.62	PK
H	12010.00	43.41	31.02	8.99	25.57	46.95	54.00	-7.05	AV

Polar (H/V)	Frequency	Meter Reading	Pre-amplifier	Cable Loss	Antenna Factor	Emission Level	Limits	Margin	Detector Type
	(MHz)	(dBuV)	(dB)	(dB)	(dB)	(dBuV/m)	(dBuV/m)	(dB)	
Middle Channel:2441MHz									
V	4882.00	54.90	30.55	5.77	24.66	54.78	74.00	-19.22	PK
V	4882.00	43.16	30.55	5.77	24.66	43.04	54.00	-10.96	AV
V	7323.00	51.51	30.33	6.32	24.55	52.05	74.00	-21.95	PK
V	7323.00	43.92	30.33	6.32	24.55	44.46	54.00	-9.54	AV
V	9764.00	52.68	30.85	7.45	24.69	53.97	74.00	-20.03	PK
V	9764.00	43.08	30.85	7.45	24.69	44.37	54.00	-9.63	AV
V	12205.00	54.86	31.02	8.99	25.57	58.40	74.00	-15.60	PK
V	12205.00	43.92	31.02	8.99	25.57	47.46	54.00	-6.54	AV
H	4882.00	54.04	30.55	5.77	24.66	53.92	74.00	-20.08	PK
H	4882.00	43.29	30.55	5.77	24.66	43.17	54.00	-10.83	AV
H	7323.00	50.02	30.33	6.32	24.55	50.56	74.00	-23.44	PK
H	7323.00	43.44	30.33	6.32	24.55	43.98	54.00	-10.02	AV
H	9764.00	52.43	30.85	7.45	24.69	53.72	74.00	-20.28	PK
H	9764.00	43.66	30.85	7.45	24.69	44.95	54.00	-9.05	AV
H	12205.00	54.39	31.02	8.99	25.57	57.93	74.00	-16.07	PK
H	12205.00	43.74	31.02	8.99	25.57	47.28	54.00	-6.72	AV

Polar (H/V)	Frequency	Meter Reading	Pre-ampli fier	Cable Loss	Antenna Factor	Emission Level	Limits	Margin	Detector Type
	(MHz)	(dBuV)	(dB)	(dB)	(dB)	(dBuV/m)	(dBuV/m)	(dB)	
High Channel:2480MHz									
V	4960.00	51.33	30.55	5.77	24.66	51.21	74.00	-22.79	PK
V	4960.00	43.94	30.55	5.77	24.66	43.82	54.00	-10.18	AV
V	7440.00	52.50	30.33	6.32	24.55	53.04	74.00	-20.96	PK
V	7440.00	43.80	30.33	6.32	24.55	44.34	54.00	-9.66	AV
V	9920.00	54.95	30.85	7.45	24.69	56.24	74.00	-17.76	PK
V	9920.00	43.34	30.85	7.45	24.69	44.63	54.00	-9.37	AV
V	12400.00	51.06	31.02	8.99	25.57	54.60	74.00	-19.40	PK
V	12400.00	43.25	31.02	8.99	25.57	46.79	54.00	-7.21	AV
H	4960.00	50.01	30.55	5.77	24.66	49.89	74.00	-24.11	PK
H	4960.00	43.85	30.55	5.77	24.66	43.73	54.00	-10.27	AV
H	7440.00	52.24	30.33	6.32	24.55	52.78	74.00	-21.22	PK
H	7440.00	43.89	30.33	6.32	24.55	44.43	54.00	-9.57	AV
H	9920.00	51.95	30.85	7.45	24.69	53.24	74.00	-20.76	PK
H	9920.00	43.37	30.85	7.45	24.69	44.66	54.00	-9.34	AV
H	12400.00	51.38	31.02	8.99	25.57	54.92	74.00	-19.08	PK
H	12400.00	43.93	31.02	8.99	25.57	47.47	54.00	-6.53	AV

Remark:

1. Emission Level = Meter Reading + Antenna Factor + Cable Loss – Pre-amplifier,  
Margin= Emission Level - Limit
2. If peak below the average limit, the average emission was no test.
3. The amplitude of spurious emissions which are attenuated by more than 20dB below the permissible value has no need to be reported.



8-DPSK - 3-DH1

Polar (H/V)	Frequency	Meter Reading	Pre-amplifier	Cable Loss	Antenna Factor	Emission Level	Limits	Margin	Detector Type
	(MHz)	(dBuV)	(dB)	(dB)	(dB)	(dBuV/m)	(dBuV/m)	(dB)	
Low Channel:2402MHz									
V	4804.00	54.18	30.55	5.77	24.66	54.06	74.00	-19.94	PK
V	4804.00	43.43	30.55	5.77	24.66	43.31	54.00	-10.69	AV
V	7206.00	51.82	30.33	6.32	24.55	52.36	74.00	-21.64	PK
V	7206.00	43.86	30.33	6.32	24.55	44.40	54.00	-9.60	AV
V	9608.00	51.90	30.85	7.45	24.69	53.19	74.00	-20.81	PK
V	9608.00	43.79	30.85	7.45	24.69	45.08	54.00	-8.92	AV
V	12010.00	54.32	31.02	8.99	25.57	57.86	74.00	-16.14	PK
V	12010.00	43.76	31.02	8.99	25.57	47.30	54.00	-6.70	AV
H	4804.00	53.00	30.55	5.77	24.66	52.88	74.00	-21.12	PK
H	4804.00	43.46	30.55	5.77	24.66	43.34	54.00	-10.66	AV
H	7206.00	54.39	30.33	6.32	24.55	54.93	74.00	-19.07	PK
H	7206.00	43.73	30.33	6.32	24.55	44.27	54.00	-9.73	AV
H	9608.00	52.60	30.85	7.45	24.69	53.89	74.00	-20.11	PK
H	9608.00	43.82	30.85	7.45	24.69	45.11	54.00	-8.89	AV
H	12010.00	52.04	31.02	8.99	25.57	55.58	74.00	-18.42	PK
H	12010.00	43.32	31.02	8.99	25.57	46.86	54.00	-7.14	AV

Polar (H/V)	Frequency	Meter Reading	Pre-amplifier	Cable Loss	Antenna Factor	Emission Level	Limits	Margin	Detector Type
	(MHz)	(dBuV)	(dB)	(dB)	(dB)	(dBuV/m)	(dBuV/m)	(dB)	
Middle Channel:2441MHz									
V	4882.00	51.95	30.55	5.77	24.66	51.83	74.00	-22.17	PK
V	4882.00	43.25	30.55	5.77	24.66	43.13	54.00	-10.87	AV
V	7323.00	53.87	30.33	6.32	24.55	54.41	74.00	-19.59	PK
V	7323.00	43.59	30.33	6.32	24.55	44.13	54.00	-9.87	AV
V	9764.00	52.62	30.85	7.45	24.69	53.91	74.00	-20.09	PK
V	9764.00	43.76	30.85	7.45	24.69	45.05	54.00	-8.95	AV
V	12205.00	53.28	31.02	8.99	25.57	56.82	74.00	-17.18	PK
V	12205.00	43.27	31.02	8.99	25.57	46.81	54.00	-7.19	AV
H	4882.00	50.60	30.55	5.77	24.66	50.48	74.00	-23.52	PK
H	4882.00	43.20	30.55	5.77	24.66	43.08	54.00	-10.92	AV
H	7323.00	52.98	30.33	6.32	24.55	53.52	74.00	-20.48	PK
H	7323.00	43.73	30.33	6.32	24.55	44.27	54.00	-9.73	AV
H	9764.00	51.38	30.85	7.45	24.69	52.67	74.00	-21.33	PK
H	9764.00	43.85	30.85	7.45	24.69	45.14	54.00	-8.86	AV
H	12205.00	50.31	31.02	8.99	25.57	53.85	74.00	-20.15	PK
H	12205.00	43.34	31.02	8.99	25.57	46.88	54.00	-7.12	AV

Polar (H/V)	Frequency	Meter Reading	Pre-ampli fier	Cable Loss	Antenna Factor	Emission Level	Limits	Margin	Detector Type
	(MHz)	(dBuV)	(dB)	(dB)	(dB)	(dBuV/m)	(dBuV/m)	(dB)	
High Channel:2480MHz									
V	4960.00	54.17	30.55	5.77	24.66	54.05	74.00	-19.95	PK
V	4960.00	43.62	30.55	5.77	24.66	43.50	54.00	-10.50	AV
V	7440.00	53.26	30.33	6.32	24.55	53.80	74.00	-20.20	PK
V	7440.00	43.43	30.33	6.32	24.55	43.97	54.00	-10.03	AV
V	9920.00	53.33	30.85	7.45	24.69	54.62	74.00	-19.38	PK
V	9920.00	43.29	30.85	7.45	24.69	44.58	54.00	-9.42	AV
V	12400.00	54.37	31.02	8.99	25.57	57.91	74.00	-16.09	PK
V	12400.00	43.19	31.02	8.99	25.57	46.73	54.00	-7.27	AV
H	4960.00	53.86	30.55	5.77	24.66	53.74	74.00	-20.26	PK
H	4960.00	43.55	30.55	5.77	24.66	43.43	54.00	-10.57	AV
H	7440.00	54.38	30.33	6.32	24.55	54.92	74.00	-19.08	PK
H	7440.00	43.28	30.33	6.32	24.55	43.82	54.00	-10.18	AV
H	9920.00	53.46	30.85	7.45	24.69	54.75	74.00	-19.25	PK
H	9920.00	43.45	30.85	7.45	24.69	44.74	54.00	-9.26	AV
H	12400.00	50.11	31.02	8.99	25.57	53.65	74.00	-20.35	PK
H	12400.00	43.40	31.02	8.99	25.57	46.94	54.00	-7.06	AV

Remark:

1. Emission Level = Meter Reading + Antenna Factor + Cable Loss – Pre-amplifier,  
Margin= Emission Level - Limit
2. If peak below the average limit, the average emission was no test.
3. The amplitude of spurious emissions which are attenuated by more than 20dB below the permissible value has no need to be reported.

## 5. RADIATED BAND EMISSION MEASUREMENT

### 5.1 TEST REQUIREMENT

Test Requirement:	FCC Part15 C Section 15.209 and 15.205 and 15.247(d)				
Test Method:	ANSI C63.10: 2013				
Test Frequency Range:	All of the restrict bands were tested, only the worst band's (2310MHz to 2500MHz) data was showed.				
Test site:	Measurement Distance: 3m				
Receiver setup:	Frequency	Detector	RBW	VBW	Value
	Above 1GHz	Peak	1MHz	3MHz	Peak
		Average	1MHz	3MHz	Average

### LIMITS OF RADIATED EMISSION MEASUREMENT (Above 1000MHz)

FREQUENCY (MHz)	Limit (dBuV/m) (at 3M)	
	PEAK	AVERAGE
Above 1000	74	54

Notes:

- (1) The limit for radiated test was performed according to FCC PART 15C.
- (2) The tighter limit applies at the band edges.
- (3) Emission level (dBuV/m)=20log Emission level (uV/m).

Spectrum Parameter	Setting
Attenuation	Auto
Start Frequency	2310MHz
Stop Frequency	2500MHz
RB / VB (emission in restricted band)	1 MHz / 3 MHz for Peak, 1 MHz / 3MHz for Average

### 5.2 TEST PROCEDURE

Above 1GHz test procedure as below:

- a. 1. The EUT was placed on the top of a rotating table 0.8meters above the ground at a 3 meter camber. The table was rotated 360 degrees to determine the position of the highest radiation.
- b. The EUT was set 3 meters away from the interference-receiving antenna, which was mounted on the top of a variable-height antenna tower.
- c. The antenna height is varied from one meter to four meters above the ground to determine the maximum value of the field strength. Both horizontal and vertical polarizations of the antenna are set to make the measurement.
- d. For each suspected emission, the EUT was arranged to its worst case and then the antenna was tuned to heights from 1 meter to 4 meters and the rota table was turned from 0 degrees to 360 degrees to find the maximum reading.
- e. The test-receiver system was set to Peak Detect Function and Specified Bandwidth with Maximum Hold Mode.
- f. If the emission level of the EUT in peak mode was 10dB lower than the limit specified, then testing could be stopped and the peak values of the EUT would be reported. Otherwise the emissions that did not have 10dB margin would be re-tested one by one using peak, quasi-peak or average method as specified and then reported in a data sheet.
- g. Test the EUT in the lowest channel,the Highest channel

Note:

Both horizontal and vertical antenna polarities were tested and performed pretest to three orthogonal axis. The worst case emissions were reported

### 5.3 DEVIATION FROM TEST STANDARD

No deviation

### 5.4 TEST SETUP

Radiated Emission Test-Up Frequency Above 1GHz

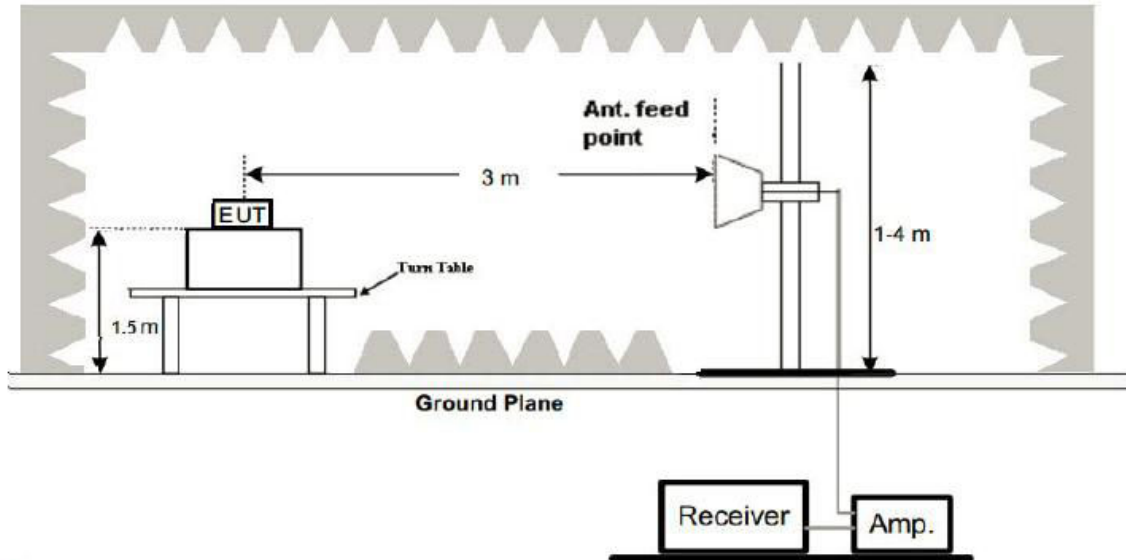

### 5.5 EUT OPERATING CONDITIONS

The EUT was configured for testing in a typical fashion (as a customer would normally use it). The EUT has been programmed to continuously transmit during test. This operating condition was tested and used to collect the included data.

5.6 TEST RESULT

	Polar (H/V)	Frequency (MHz)	Meter Reading (dBUV)	Pre-amplifier (dB)	Cable Loss (dB)	Antenna Factor (dB/m)	Emission level (dBUV/m)	Limit (dBU V/m)	Margin (dB)	Detect or Type	Result
GFSK 1-DH1	Low Channel: 2402MHz										
	H	2310.00	53.49	30.22	4.85	23.98	52.10	74.00	-21.90	PK	PASS
	H	2310.00	44.93	30.22	4.85	23.98	43.54	54.00	-10.46	AV	PASS
	H	2350.00	54.08	30.22	4.85	23.98	52.69	74.00	-21.31	PK	PASS
	H	2350.00	44.62	30.22	4.85	23.98	43.23	54.00	-10.77	AV	PASS
	H	2390.00	53.76	30.22	4.85	23.98	52.37	74.00	-21.63	PK	PASS
	H	2390.00	44.58	30.22	4.85	23.98	43.19	54.00	-10.81	AV	PASS
	V	2310.00	53.68	30.22	4.85	23.98	52.29	74.00	-21.71	PK	PASS
	V	2310.00	44.41	30.22	4.85	23.98	43.02	54.00	-10.98	AV	PASS
	V	2350.00	54.89	30.22	4.85	23.98	53.50	74.00	-20.50	PK	PASS
	V	2350.00	44.96	30.22	4.85	23.98	43.57	54.00	-10.43	AV	PASS
	V	2390.00	53.02	30.22	4.85	23.98	51.63	74.00	-22.37	PK	PASS
	V	2390.00	44.94	30.22	4.85	23.98	43.55	54.00	-10.45	AV	PASS
	High Channel: 2480MHz										
	H	2483.50	53.35	30.22	4.85	23.98	51.96	74.00	-22.04	PK	PASS
	H	2483.50	44.12	30.22	4.85	23.98	42.73	54.00	-11.27	AV	PASS
	H	2490.00	53.60	30.22	4.85	23.98	52.21	74.00	-21.79	PK	PASS
	H	2490.00	44.45	30.22	4.85	23.98	43.06	54.00	-10.94	AV	PASS
	H	2500.00	54.12	30.22	4.85	23.98	52.73	74.00	-21.27	PK	PASS
	H	2500.00	44.50	30.22	4.85	23.98	43.11	54.00	-10.89	AV	PASS
	V	2483.50	53.28	30.22	4.85	23.98	51.89	74.00	-22.11	PK	PASS
	V	2483.50	44.40	30.22	4.85	23.98	43.01	54.00	-10.99	AV	PASS
	V	2490.00	54.40	30.22	4.85	23.98	53.01	74.00	-20.99	PK	PASS
	V	2490.00	44.43	30.22	4.85	23.98	43.04	54.00	-10.96	AV	PASS
V	2500.00	54.72	30.22	4.85	23.98	53.33	74.00	-20.67	PK	PASS	
V	2500.00	44.53	30.22	4.85	23.98	43.14	54.00	-10.86	AV	PASS	
π/4-DQ PSK 2-DH1	Low Channel: 2402MHz										
	H	2310.00	54.44	30.22	4.85	23.98	53.05	74.00	-20.95	PK	PASS
	H	2310.00	44.64	30.22	4.85	23.98	43.25	54.00	-10.75	AV	PASS
	H	2350.00	54.08	30.22	4.85	23.98	52.69	74.00	-21.31	PK	PASS
	H	2350.00	44.83	30.22	4.85	23.98	43.44	54.00	-10.56	AV	PASS
	H	2390.00	54.61	30.22	4.85	23.98	53.22	74.00	-20.78	PK	PASS
	H	2390.00	44.07	30.22	4.85	23.98	42.68	54.00	-11.32	AV	PASS
	V	2310.00	54.38	30.22	4.85	23.98	52.99	74.00	-21.01	PK	PASS
	V	2310.00	44.49	30.22	4.85	23.98	43.10	54.00	-10.90	AV	PASS
	V	2350.00	54.88	30.22	4.85	23.98	53.49	74.00	-20.51	PK	PASS
	V	2350.00	44.46	30.22	4.85	23.98	43.07	54.00	-10.93	AV	PASS
	V	2390.00	53.51	30.22	4.85	23.98	52.12	74.00	-21.88	PK	PASS
	V	2390.00	44.75	30.22	4.85	23.98	43.36	54.00	-10.64	AV	PASS
	High Channel: 2480MHz										
	H	2483.50	54.05	30.22	4.85	23.98	52.66	74.00	-21.34	PK	PASS
H	2483.50	44.74	30.22	4.85	23.98	43.35	54.00	-10.65	AV	PASS	
H	2490.00	53.73	30.22	4.85	23.98	52.34	74.00	-21.66	PK	PASS	

	H	2490.00	44.78	30.22	4.85	23.98	43.39	54.00	-10.61	AV	PASS
	H	2500.00	53.89	30.22	4.85	23.98	52.50	74.00	-21.50	PK	PASS
	H	2500.00	44.43	30.22	4.85	23.98	43.04	54.00	-10.96	AV	PASS
	V	2483.50	54.96	30.22	4.85	23.98	53.57	74.00	-20.43	PK	PASS
	V	2483.50	44.15	30.22	4.85	23.98	42.76	54.00	-11.24	AV	PASS
	V	2490.00	54.00	30.22	4.85	23.98	52.61	74.00	-21.39	PK	PASS
	V	2490.00	44.00	30.22	4.85	23.98	42.61	54.00	-11.39	AV	PASS
	V	2500.00	53.73	30.22	4.85	23.98	52.34	74.00	-21.66	PK	PASS
	V	2500.00	44.01	30.22	4.85	23.98	42.62	54.00	-11.38	AV	PASS
	Low Channel: 2402MHz										
	H	2310.00	53.72	30.22	4.85	23.98	52.33	74.00	-21.67	PK	PASS
	H	2310.00	44.11	30.22	4.85	23.98	42.72	54.00	-11.28	AV	PASS
	H	2350.00	54.45	30.22	4.85	23.98	53.06	74.00	-20.94	PK	PASS
	H	2350.00	44.08	30.22	4.85	23.98	42.69	54.00	-11.31	AV	PASS
	H	2390.00	54.15	30.22	4.85	23.98	52.76	74.00	-21.24	PK	PASS
	H	2390.00	44.62	30.22	4.85	23.98	43.23	54.00	-10.77	AV	PASS
	V	2310.00	54.75	30.22	4.85	23.98	53.36	74.00	-20.64	PK	PASS
	V	2310.00	44.40	30.22	4.85	23.98	43.01	54.00	-10.99	AV	PASS
	V	2350.00	54.92	30.22	4.85	23.98	53.53	74.00	-20.47	PK	PASS
	V	2350.00	44.88	30.22	4.85	23.98	43.49	54.00	-10.51	AV	PASS
	V	2390.00	53.16	30.22	4.85	23.98	51.77	74.00	-22.23	PK	PASS
	V	2390.00	44.20	30.22	4.85	23.98	42.81	54.00	-11.19	AV	PASS
	High Channel: 2480MHz										
	H	2483.50	53.93	30.22	4.85	23.98	52.54	74.00	-21.46	PK	PASS
	H	2483.50	44.80	30.22	4.85	23.98	43.41	54.00	-10.59	AV	PASS
	H	2490.00	53.93	30.22	4.85	23.98	52.54	74.00	-21.46	PK	PASS
	H	2490.00	44.66	30.22	4.85	23.98	43.27	54.00	-10.73	AV	PASS
	H	2500.00	54.58	30.22	4.85	23.98	53.19	74.00	-20.81	PK	PASS
	H	2500.00	44.70	30.22	4.85	23.98	43.31	54.00	-10.69	AV	PASS
	V	2483.50	53.63	30.22	4.85	23.98	52.24	74.00	-21.76	PK	PASS
	V	2483.50	44.71	30.22	4.85	23.98	43.32	54.00	-10.68	AV	PASS
	V	2490.00	54.19	30.22	4.85	23.98	52.80	74.00	-21.20	PK	PASS
	V	2490.00	44.93	30.22	4.85	23.98	43.54	54.00	-10.46	AV	PASS
	V	2500.00	54.74	30.22	4.85	23.98	53.35	74.00	-20.65	PK	PASS
	V	2500.00	44.22	30.22	4.85	23.98	42.83	54.00	-11.17	AV	PASS
8-DPSK 3-DH1											
Remark: 1. Emission Level = Meter Reading + Antenna Factor + Cable Loss – Pre-amplifier, Margin= Emission Level - Limit											

## 6. CONDUCTED BAND EDGE AND SPURIOUS EMISSION

Test Requirement:	FCC Part15 C Section 15.247 (d)
Test Method:	KDB558074 D0115.247 Meas Guidancev05r02

### 6.1 LIMIT

Typical regulatory requirements specify that in any 100 kHz bandwidth outside of the authorized frequency band, the power shall be attenuated according to the following conditions:

The maximum peak conducted output power procedure was used to determine compliance as described in 11.9.1, then the peak output power measured in any 100 kHz bandwidth outside of the authorized frequency band shall be attenuated by at least 20 dB relative to the maximum in-band peak PSD level in 100 kHz (i.e., 20 dBc).

### 6.2 TEST SETUP

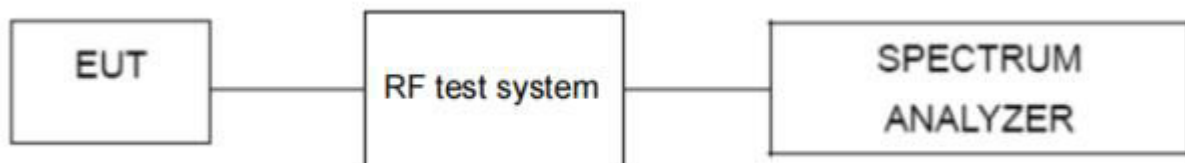

### 6.3 TEST PROCEDURE

A. Reference level measurement, establish a reference level by using the following procedure:

- a) Set instrument center frequency to FHSS channel center frequency.
- b) Set the span to  $\geq 1.5$  times the 20dB bandwidth.
- c) Set the RBW = 100 kHz.
- d) Set the VBW  $\geq [3 \times \text{RBW}]$ .
- e) Detector = peak.
- f) Sweep time = auto couple.
- g) Trace mode = max hold.
- h) Allow trace to fully stabilize.
- i) Use the peak marker function to determine the maximum PSD level.

Note that the channel found to contain the maximum PSD level can be used to establish the reference level.

B. Emission level measurement, establish an emission level by using the following procedure:

- a) Set the center frequency and span to encompass frequency range to be measured.
- b) Set the RBW = 100 kHz.
- c) Set the VBW  $\geq [3 \times \text{RBW}]$ .
- d) Detector = peak.
- e) Sweep time = auto couple.
- f) Trace mode = max hold.
- g) Allow trace to fully stabilize.
- h) Use the peak marker function to determine the maximum amplitude level.

Ensure that the amplitude of all unwanted emissions outside of the authorized frequency band (excluding restricted frequency bands) is attenuated by at least the minimum requirements specified in 11.11. Report the three highest emissions relative to the limit.

### 6.4 DEVIATION FROM STANDARD

No deviation.

6.5 TEST RESULT

GFSK - 1-DH1  
Lowest channel

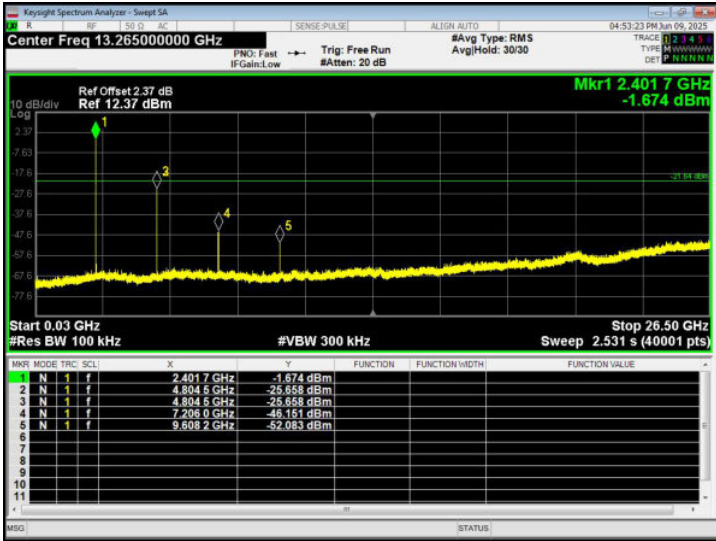
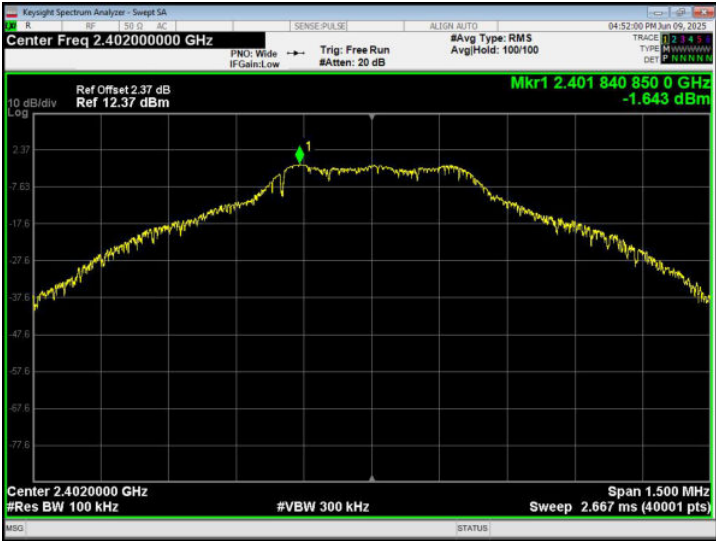

Middle channel

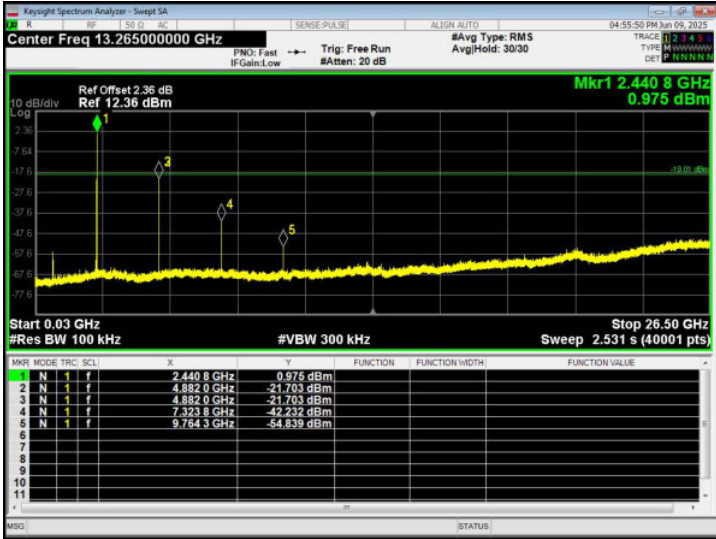
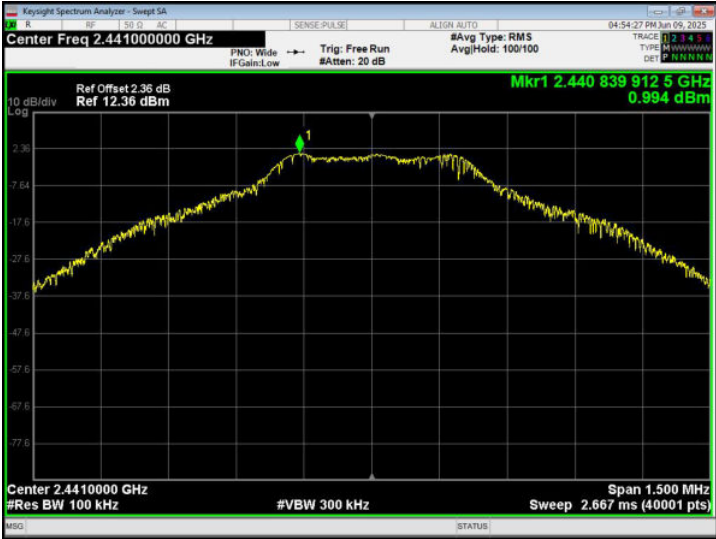

Highest channel

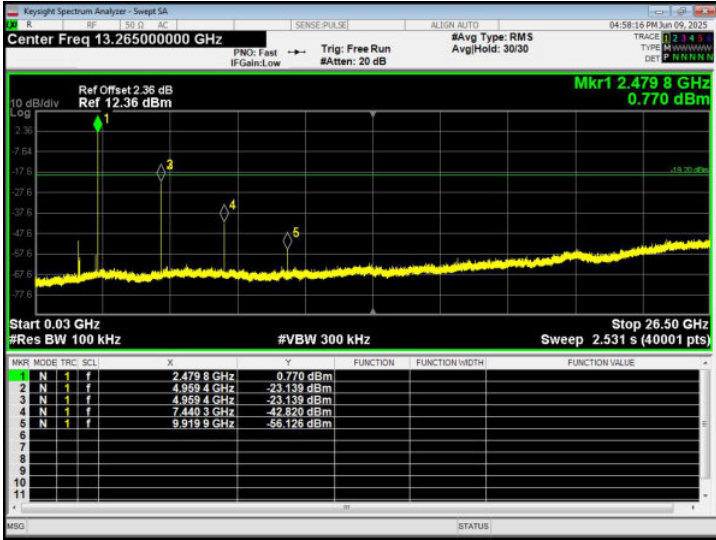
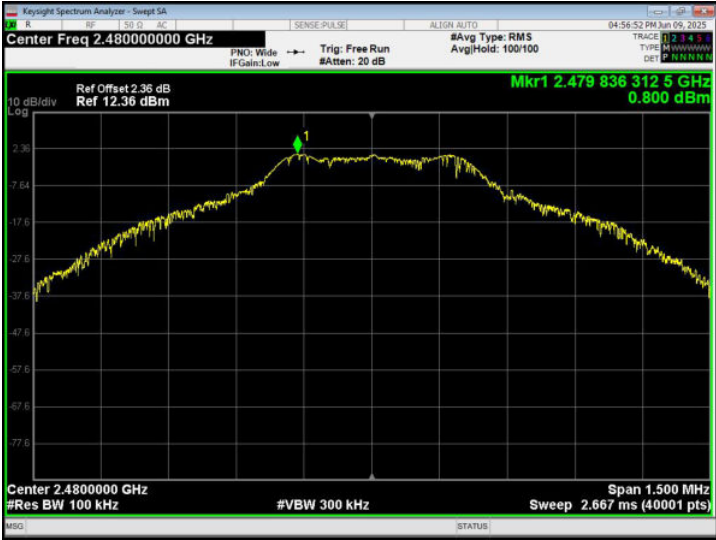

30MHz~26.5GHz



$\pi/4$ -DQPSK - 2-DH1

Lowest channel

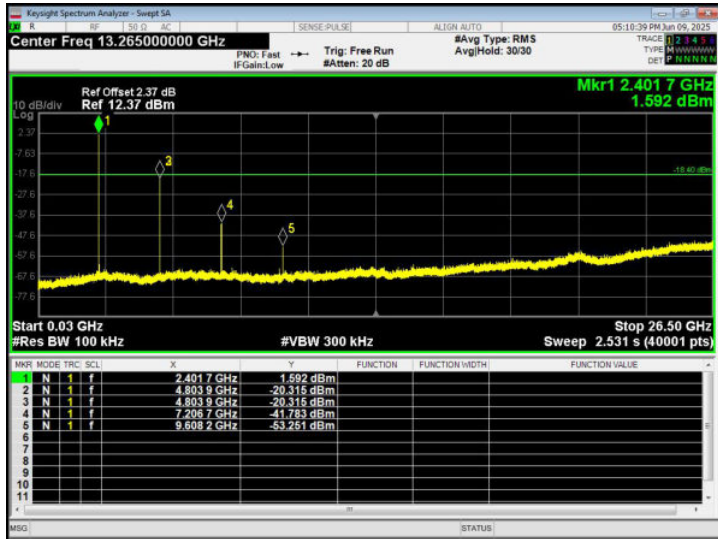

Middle channel

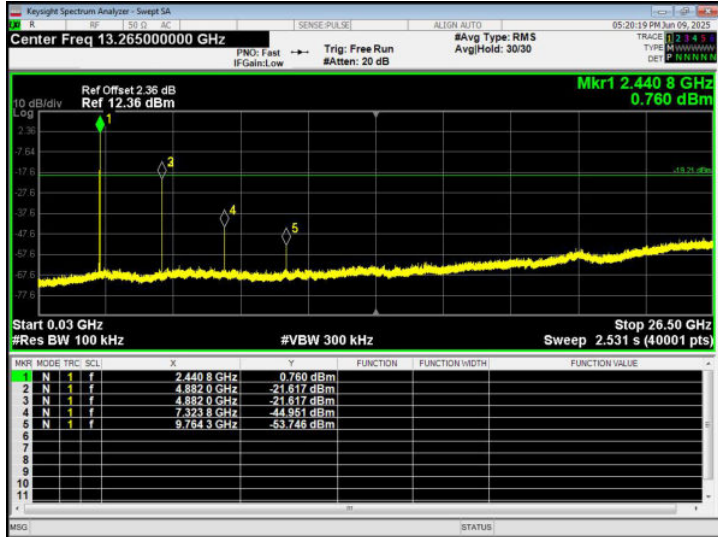

Highest channel

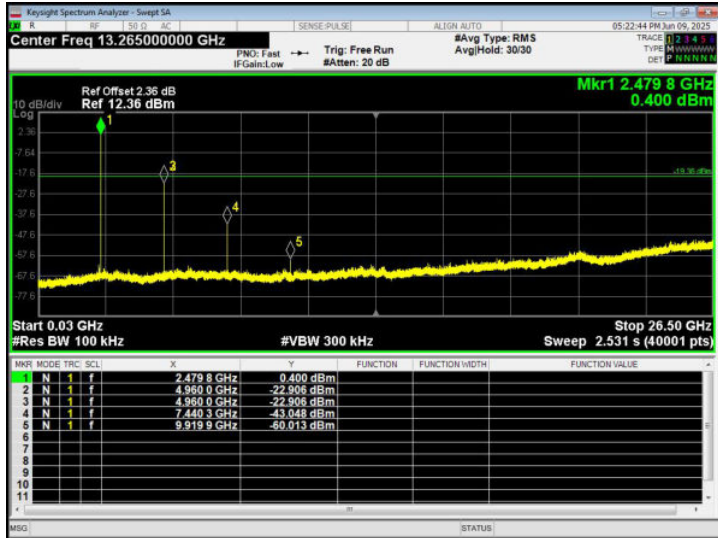

30MHz~26.5GHz

8-DPSK - 3-DH1  
 Lowest channel

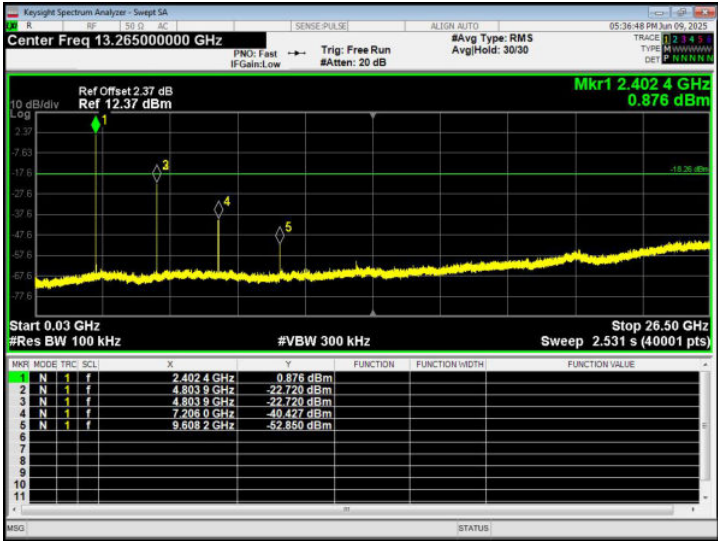
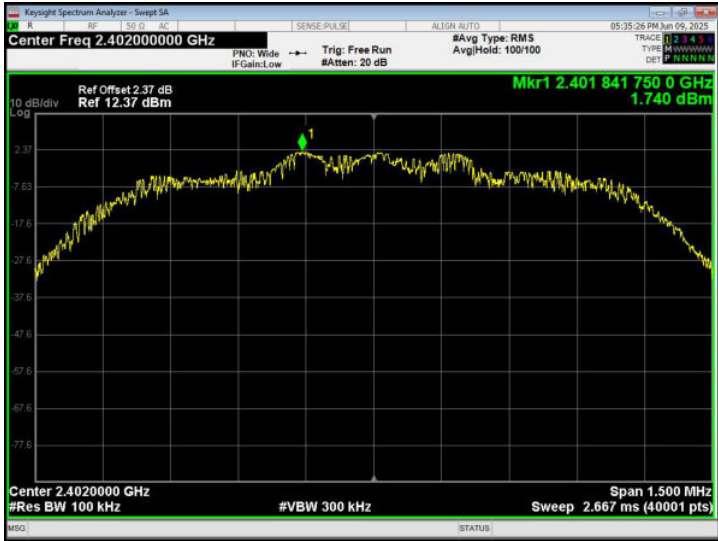

Middle channel

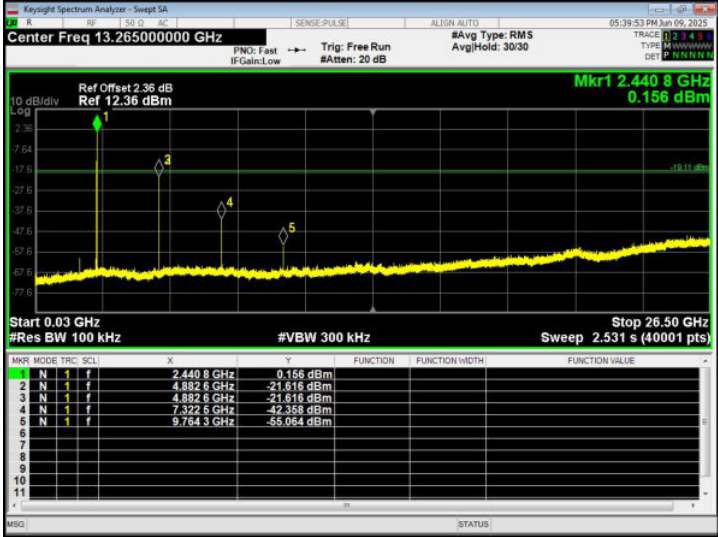
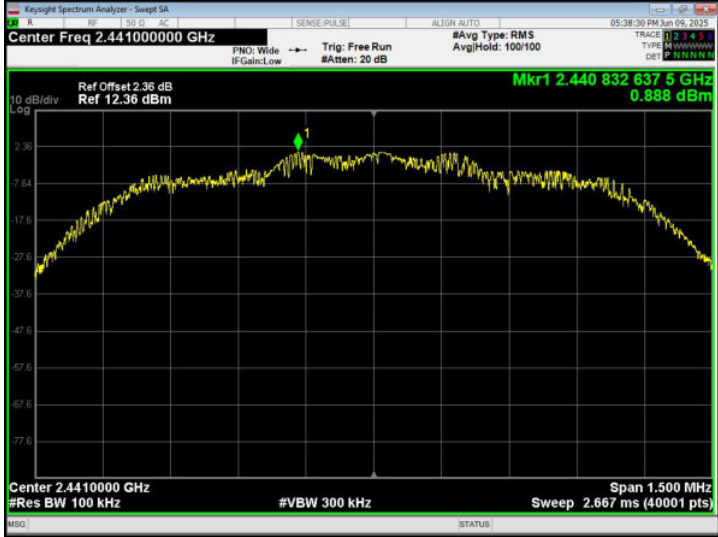

Highest channel

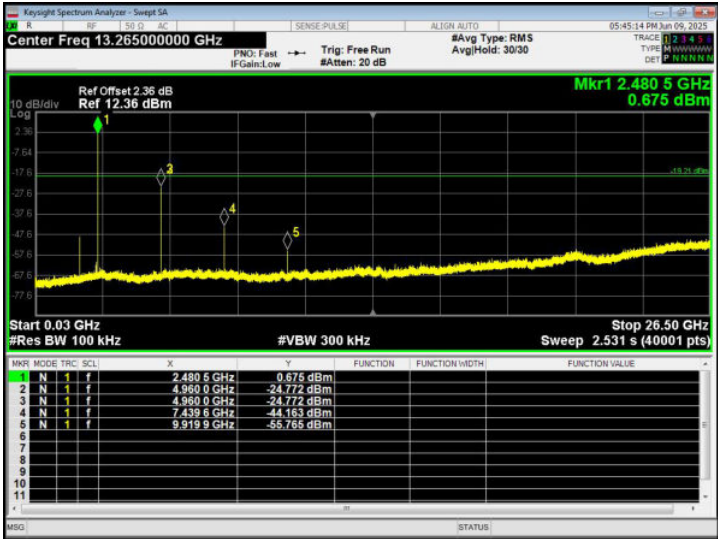

30MHz~26.5GHz

GFSK - 1-DH1

No-hopping Band edge-left side

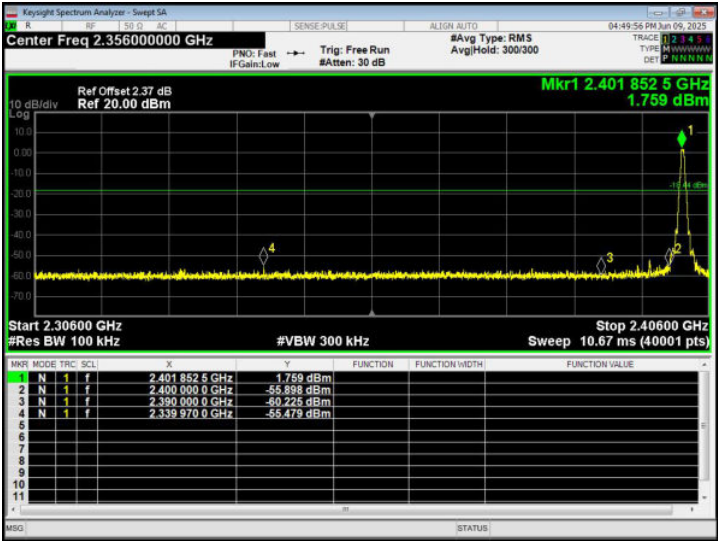

No-hopping Band edge-right side

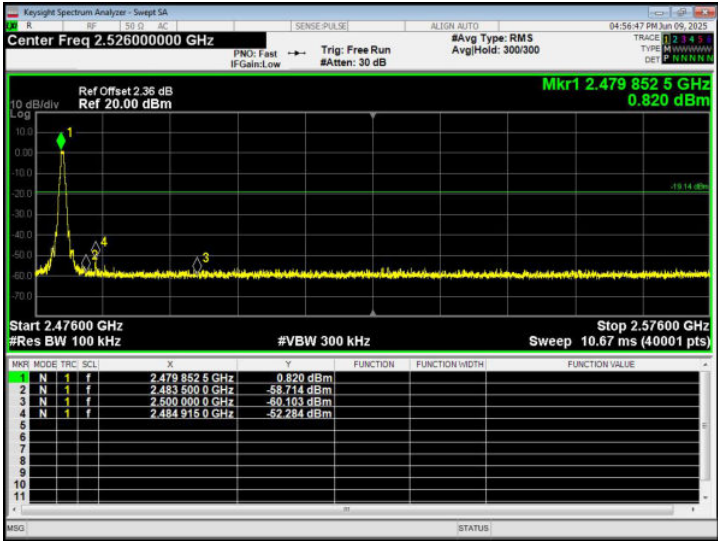

Hopping Band edge-left side

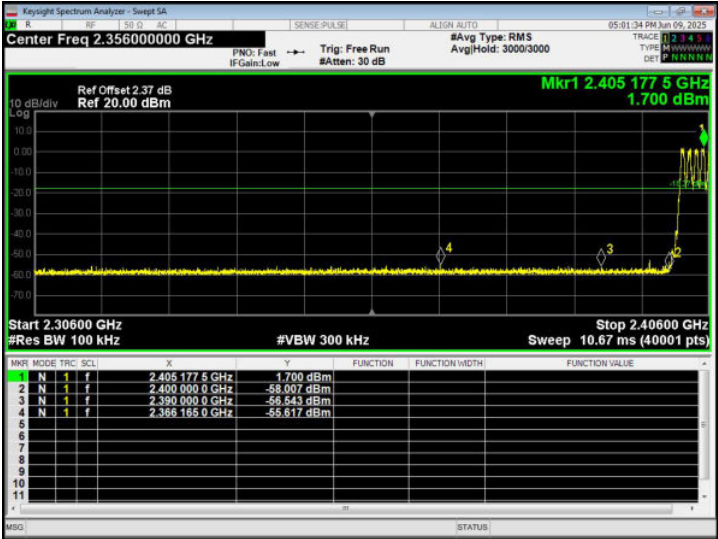

Hopping Band edge-right side

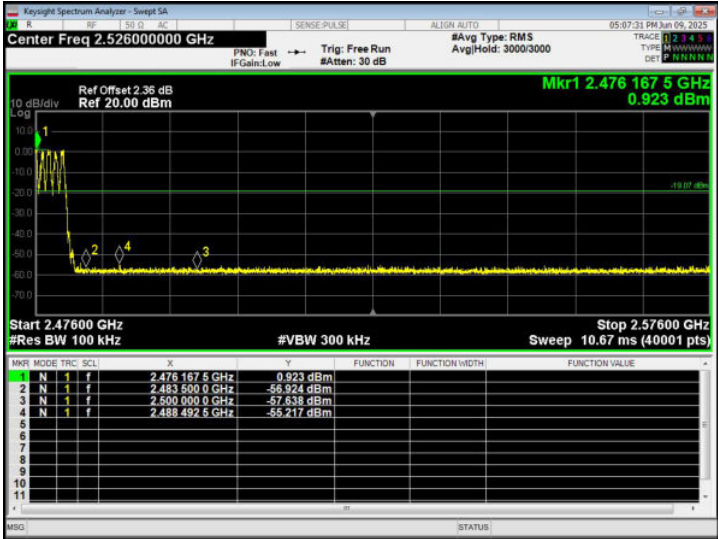

$\pi/4$ -DQPSK - 2-DH1

No-hopping Band edge-left side

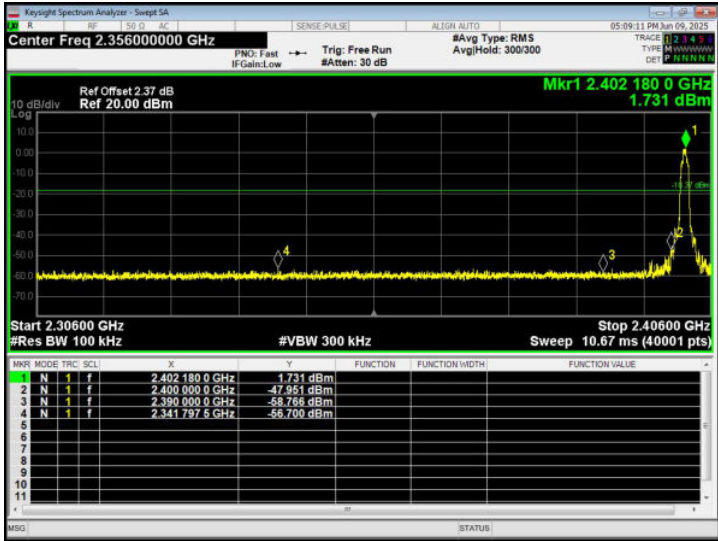

No-hopping Band edge-right side

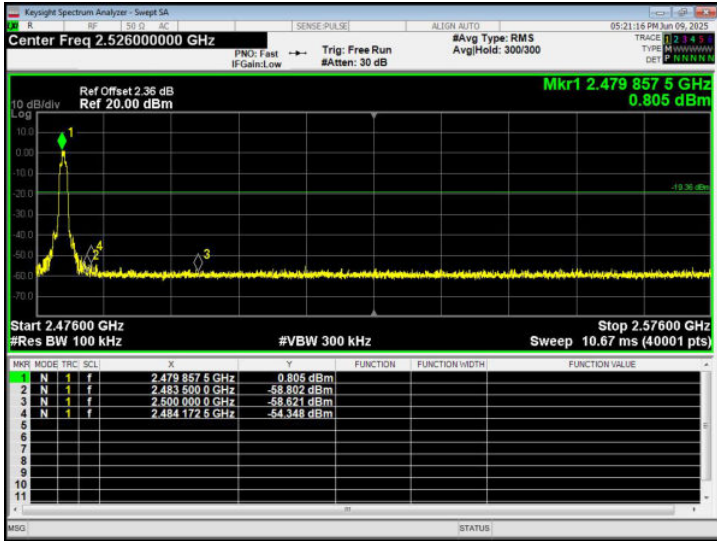

Hopping Band edge-left side

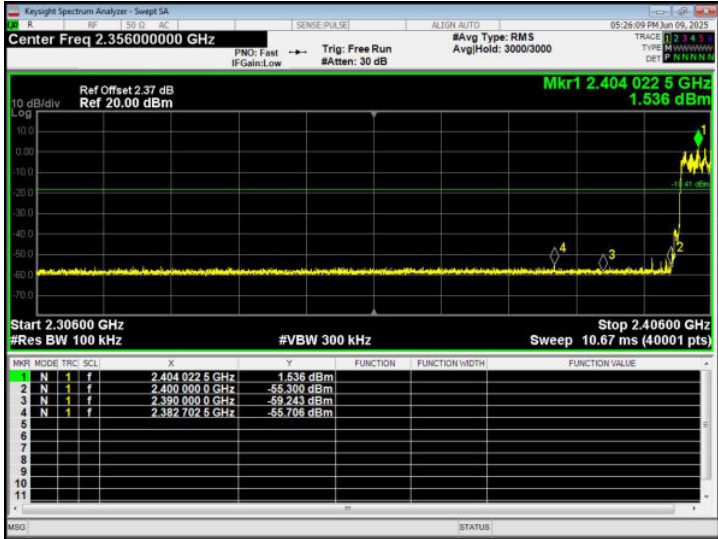

Hopping Band edge-right side

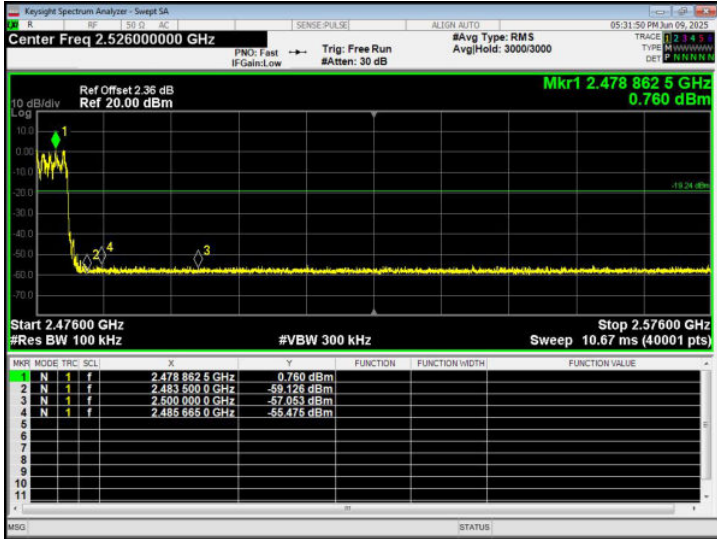

8-DPSK - 3-DH1

No-hopping Band edge-left side

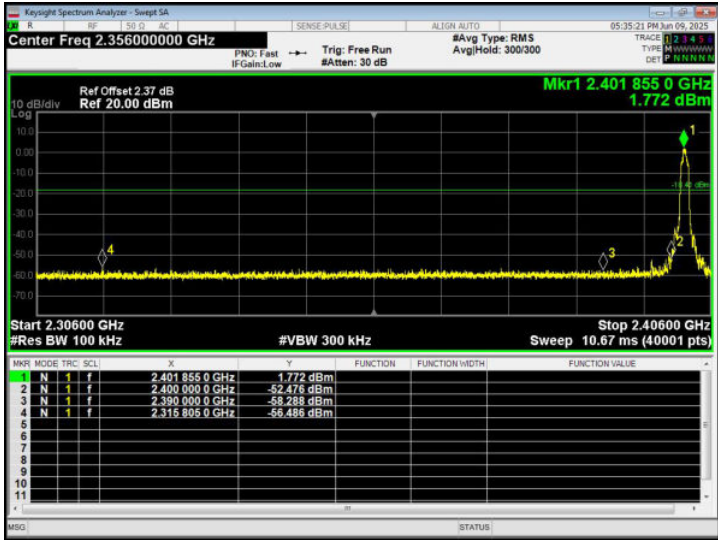

No-hopping Band edge-right side

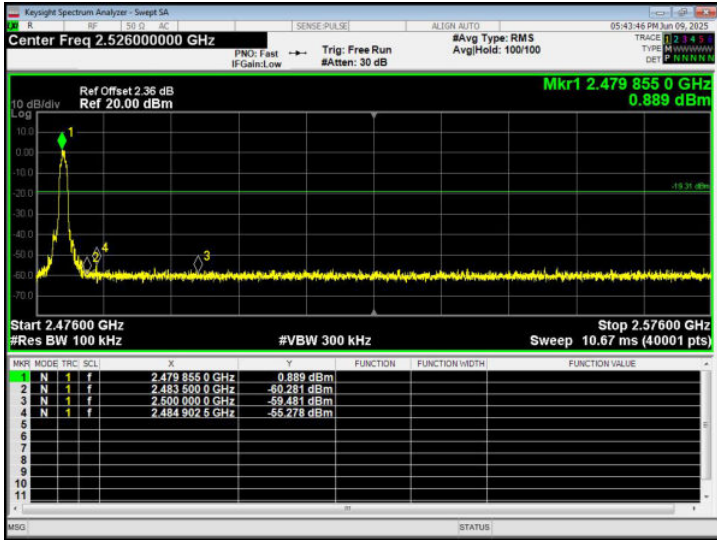

Hopping Band edge-left side

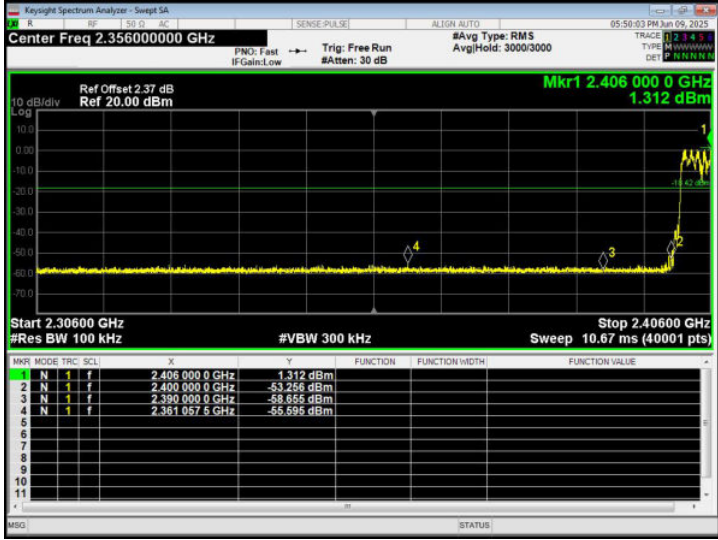

Hopping Band edge-right side

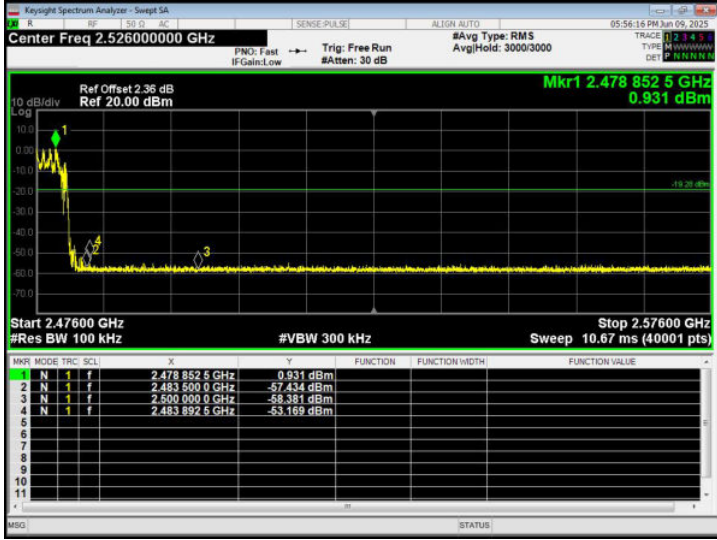

## 7. 20DB OCCUPIED BANDWIDTH

Test Requirement:	FCC Part15 C Section 15.247 (a)(1)
Test Method:	ANSI C63.10:2013

### 7.1 TEST SETUP

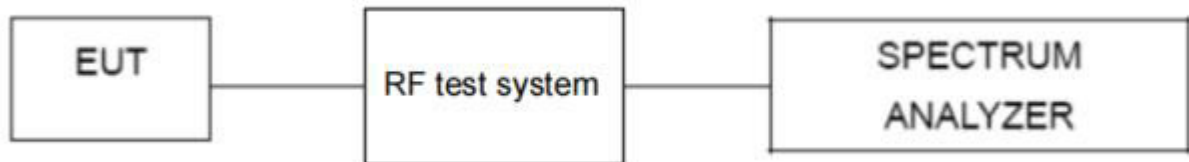

### 7.2 LIMIT

N/A

### 7.3 TEST PROCEDURE

1. Set RBW = 30 kHz.
2. Set the video bandwidth (VBW)  $\geq 3 \times$  RBW.
3. Detector = Peak.
4. Trace mode = max hold.
5. Sweep = auto couple.
6. Allow the trace to stabilize.
7. Measure the maximum width of the emission that is constrained by the frequencies associated with the two outermost amplitude points (upper and lower frequencies) that are attenuated by 20 dB relative to the maximum level measured in the fundamental emission.

### 7.4 DEVIATION FROM STANDARD

No deviation.

7.5 TEST RESULT

Modulation	Packet	Test Channel	20dB Occupied Bandwidth (MHz)	Result
GFSK	1-DH1	Lowest	0.8811	Pass
		Middle	0.8738	
		Highest	0.8727	
$\pi/4$ -DQPSK	2-DH1	Lowest	1.245	Pass
		Middle	1.242	
		Highest	1.235	
8-DPSK	3-DH1	Lowest	1.206	Pass
		Middle	1.210	
		Highest	1.205	

GFSK - 1-DH1 Test plots  
Low Channel



Middle Channel

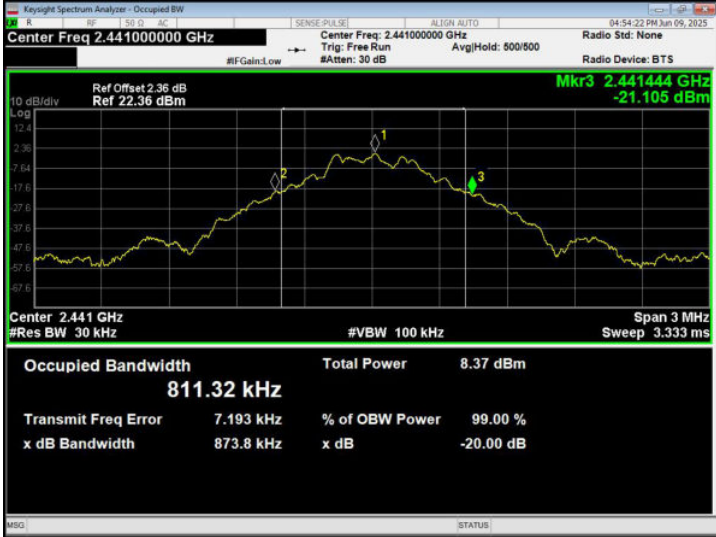

High Channel

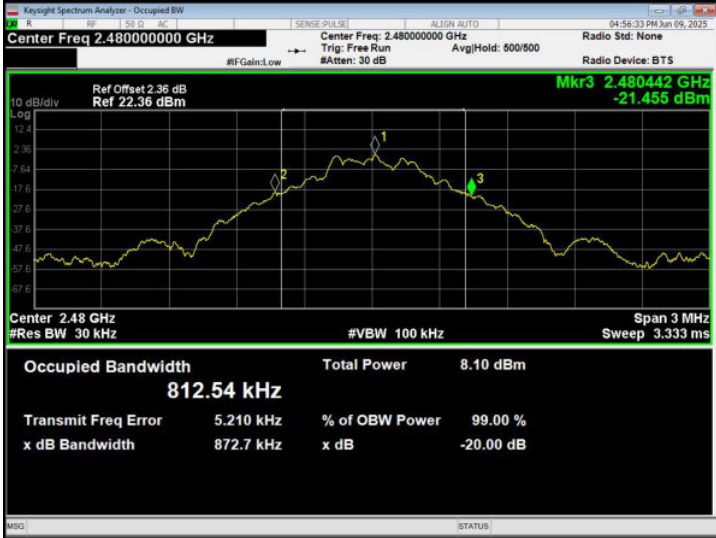



$\pi/4$ -DQPSK - 2-DH1 Test plots  
Low Channel

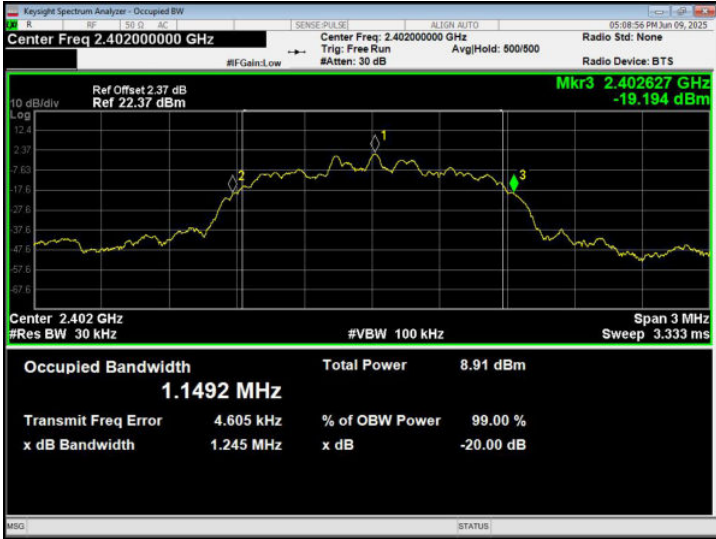

Middle Channel

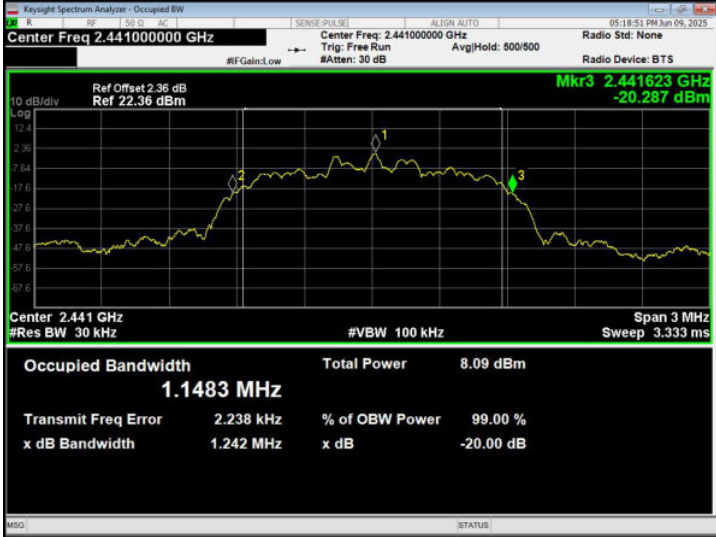

High Channel

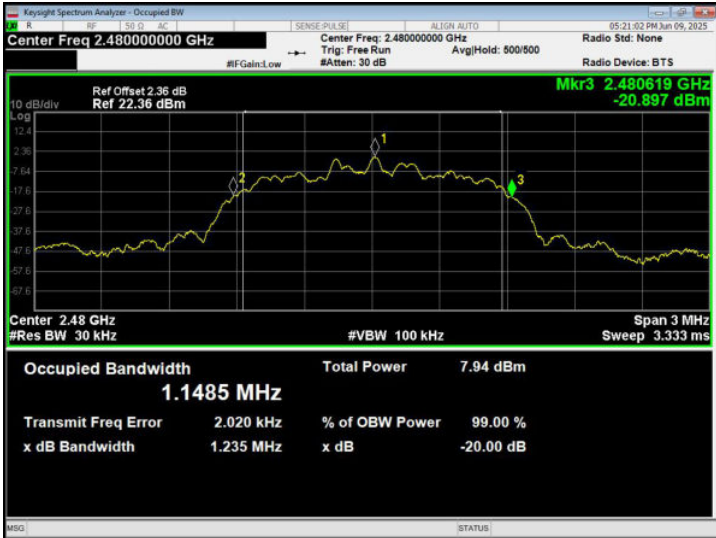

8-DPSK - 3-DH1 Test plots

Low Channel

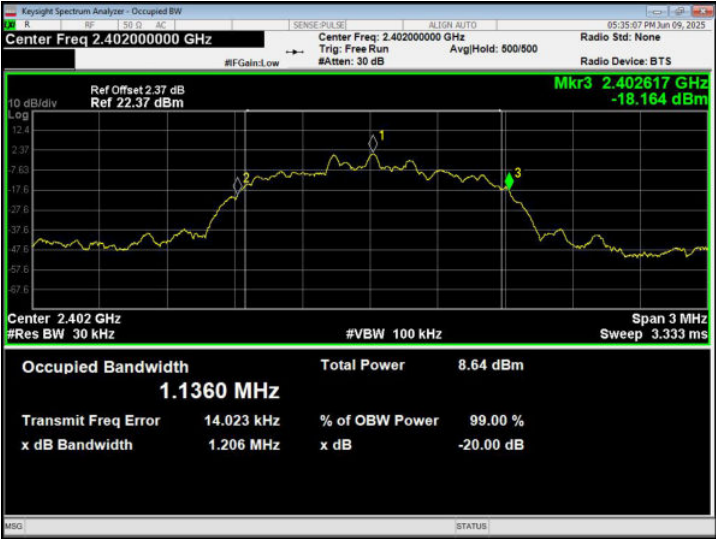

Middle Channel

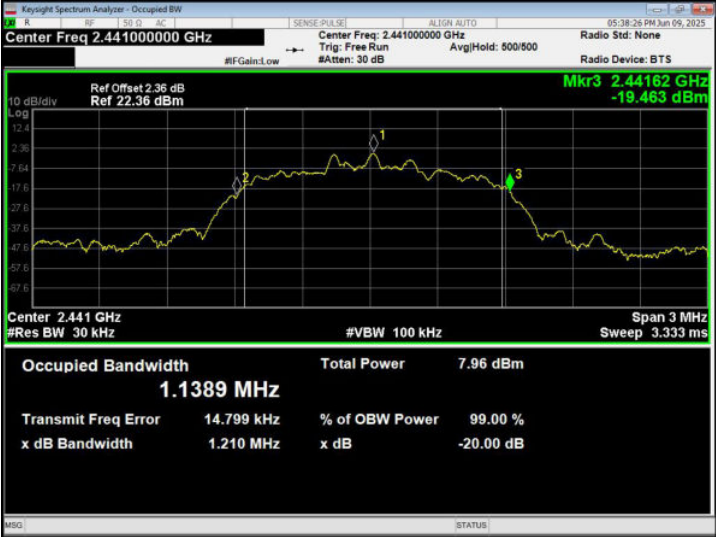

High Channel

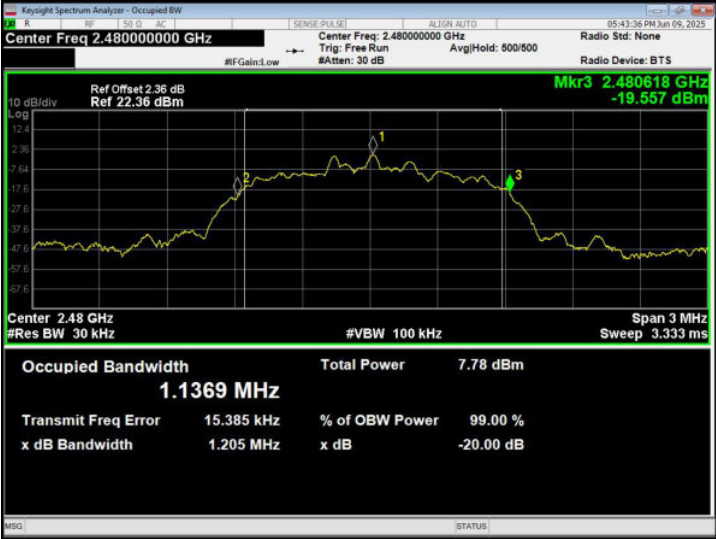

## 8. MAXIMUM PEAK OUTPUT POWER

Test Requirement:	FCC Part15 C Section 15.247 (b)(1)
Test Method:	ANSI C63.10:2013
Limit:	GFSK: 30dBm $\pi/4$ -DQPSK & 8-DPSK: 20.97dBm

### 8.1 BLOCK DIAGRAM OF TEST SETUP



### 8.2 LIMIT

For frequency hopping systems operating in the 2400-2483.5 MHz band employing at least 75 non-overlapping hopping channels, and all frequency hopping systems in the 5725-5850 MHz band: 1 watt.  
For all other frequency hopping systems in the 2400-2483.5 MHz band: 0.125 watts.

### 8.3 TEST PROCEDURE

1. Remove the antenna from the EUT and then connect a low RF cable from the antenna port to the spectrum.
2. Set the spectrum analyzer: RBW = 2MHz. VBW =6MHz. Sweep = auto; Detector Function = Peak.
3. Keep the EUT in transmitting at lowest, medium and highest channel individually. Record the max value.

### 8.4 DEVIATION FROM STANDARD

No deviation.

8.5 TEST RESULT

Modulation	Packet	Test channel	Peak output power (dBm)	Limit (dBm)	Result
GFSK	1-DH1	Lowest	1.966	30.00	Pass
		Middle	1.275		
		Highest	1.044		
$\pi/4$ -DQPSK	2-DH1	Lowest	2.871	21.00	Pass
		Middle	2.093		
		Highest	1.888		
8-DPSK	3-DH1	Lowest	3.420	21.00	Pass
		Middle	2.709		
		Highest	2.512		

GFSK - 1-DH1 Test plots  
Low Channel

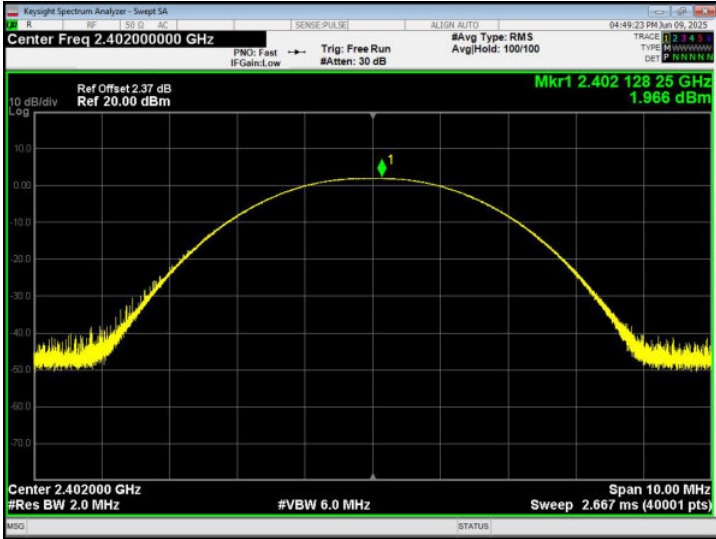

Middle Channel

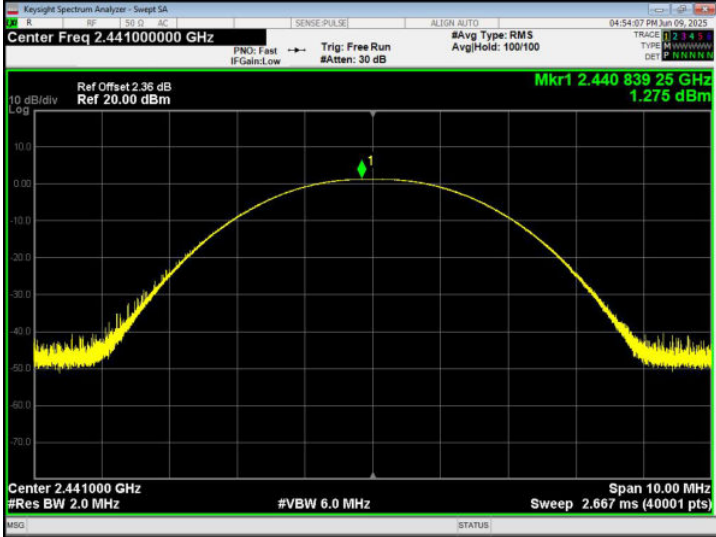

High Channel

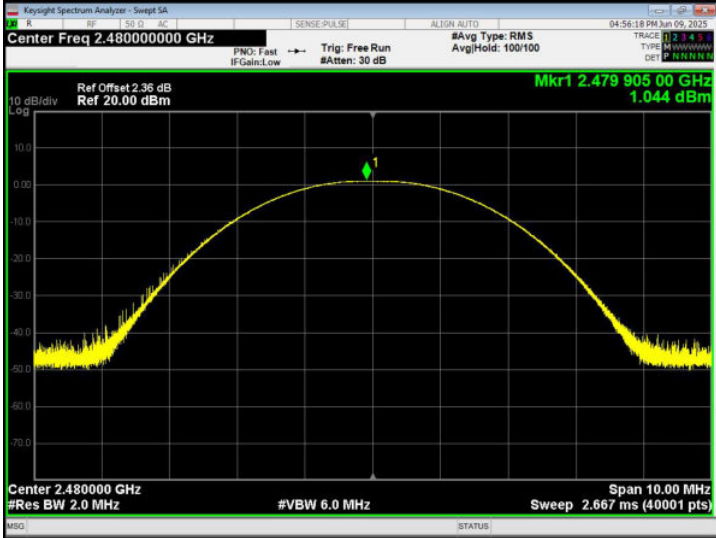

$\pi/4$ -DQPSK - 2-DH1 Test plots  
Low Channel

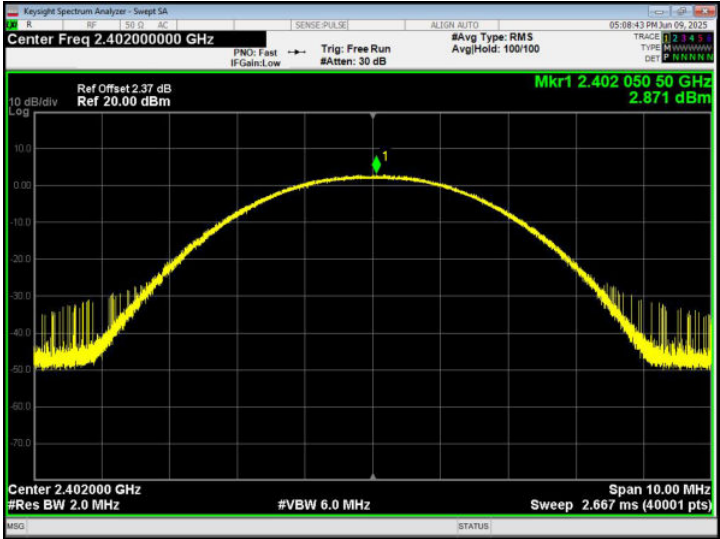

Middle Channel

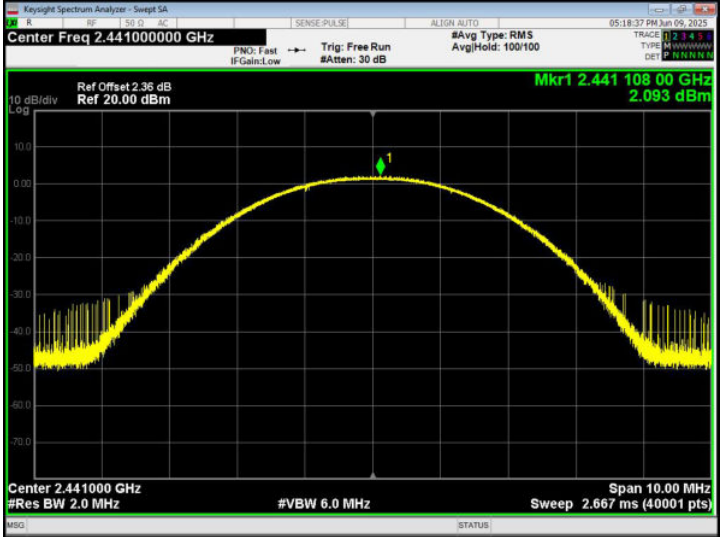

High Channel

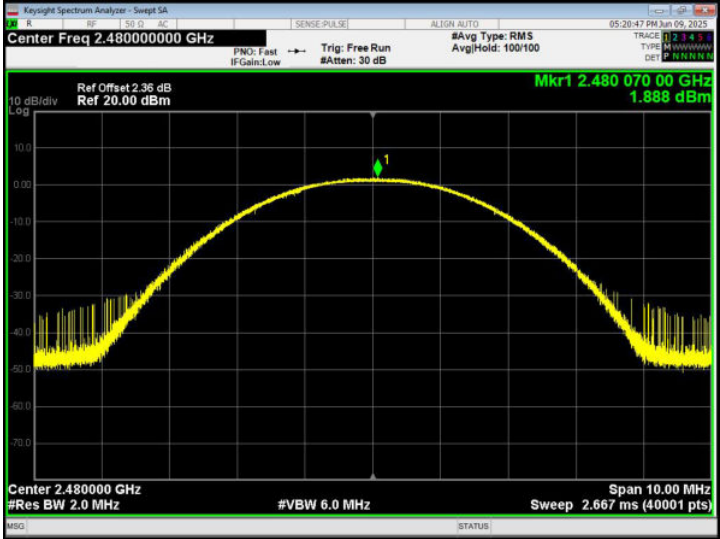

### 8-DPSK - 3-DH1 Test plots

#### Low Channel

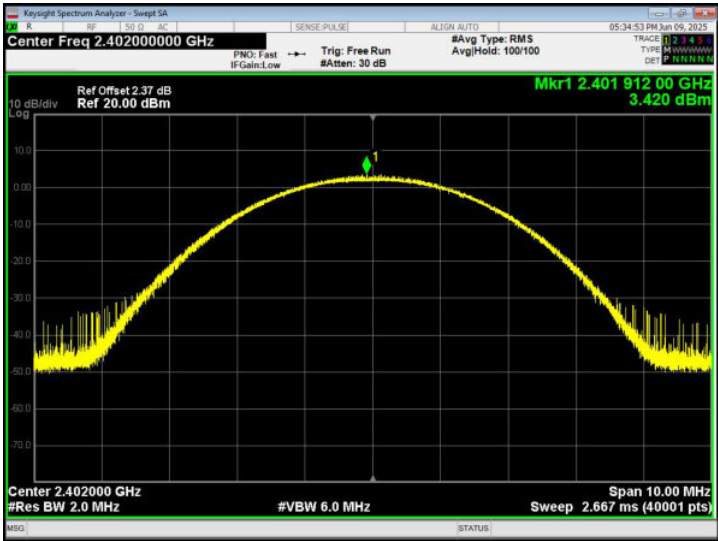

#### Middle Channel

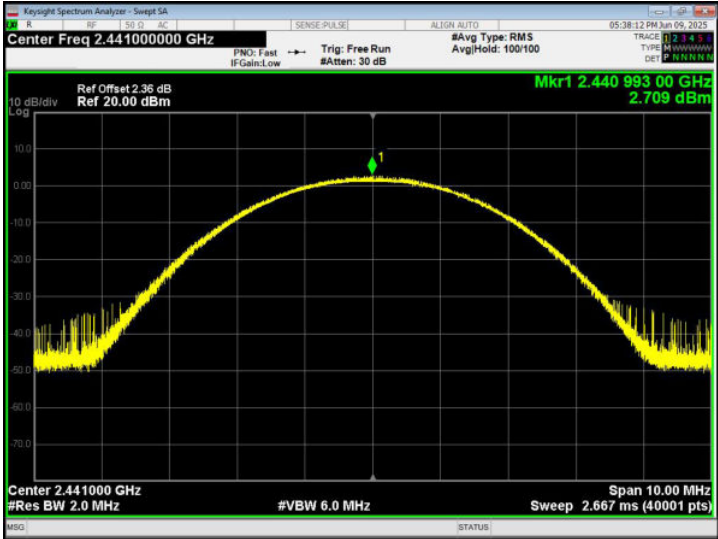

#### High Channel

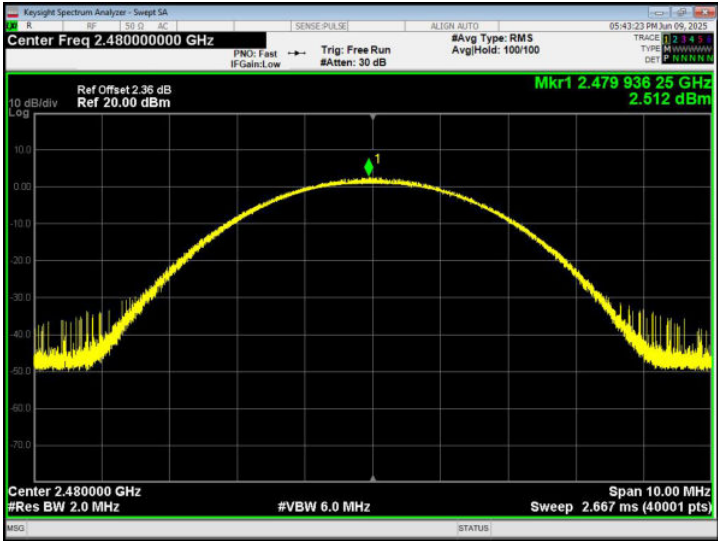

## 9. HOPPING CHANNEL SEPARATION

Test Requirement:	FCC Part15 C Section 15.247 (a)(1)
Test Method:	ANSI C63.10:2013
Receiver setup:	RBW=30KHz, VBW=100KHz, detector=Peak
Limit:	GFSK: 20dB Bandwidth $\pi/4$ -DQPSK & 8DSK: 0.025MHz or 2/3 of the 20dB Bandwidth (whichever is greater)

### 9.1 TEST SETUP

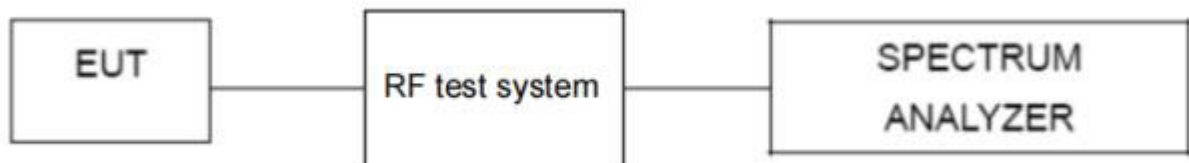

### 9.2 TEST PROCEDURE

1. Remove the antenna from the EUT and then connect a low RF cable from the antenna port to the spectrum.
2. Set the spectrum analyzer: RBW = 30kHz. VBW = 100kHz , Span = 3.0MHz. Sweep = auto; Detector Function = Peak. Trace = Max hold.
3. Allow the trace to stabilize. Use the marker-delta function to determine the separation between the peaks of the adjacent channels. The limit is specified in one of the subparagraphs of this Section Submit this plot.

### 9.3 DEVIATION FROM STANDARD

No deviation.



9.4 TEST RESULT

Modulation	Packet	Test Channel	Separation (MHz)	Limit (MHz)	Result
GFSK	1-DH1	Low	1.005	0.8811	PASS
		Middle	1.002	0.8738	PASS
		High	1.008	0.8727	PASS
$\pi/4$ -DQPSK	2-DH1	Low	0.981	0.8300	PASS
		Middle	1.011	0.8280	PASS
		High	1.002	0.8233	PASS
8-DPSK	3-DH1	Low	1.002	0.8040	PASS
		Middle	0.822	0.8067	PASS
		High	1.006	0.8033	PASS



$\pi/4$ -DQPSK - 2-DH1 Test plots

Low Channel

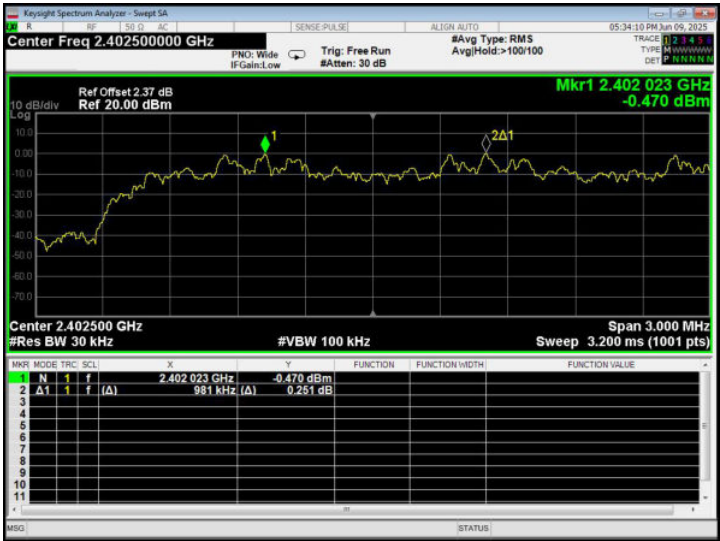

Middle Channel

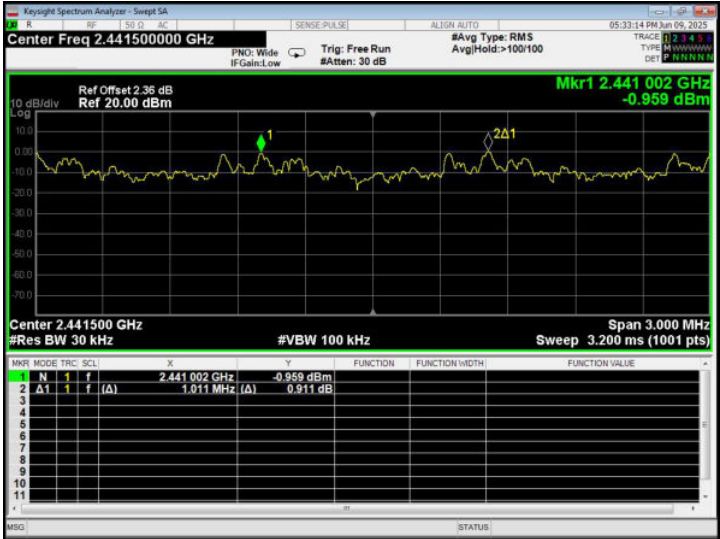

High Channel

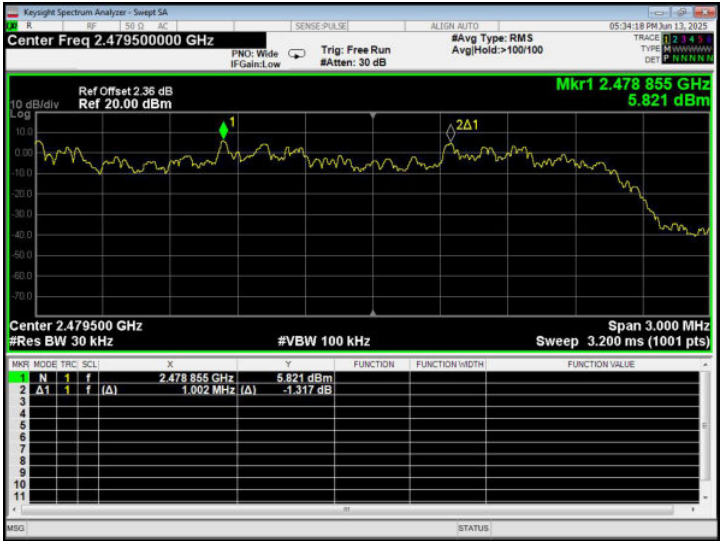



### 10.NUMBER OF HOPPING FREQUENCY

Test Requirement:	FCC Part15 C Section 15.247 (a)(1)(iii)
Test Method:	ANSI C63.10:2013
Receiver setup:	RBW = 100 kHz, VBW = 300 kHz Frequency range = 2400MHz - 2483.5MHz Detector = peak
Limit:	$P_{\max-pk} \leq 1W, N_{ch} \geq 75$ Channels $P_{\max-pk} \leq 0.125W, N_{ch} \geq 15$ Channels

#### 10.1 TEST SETUP

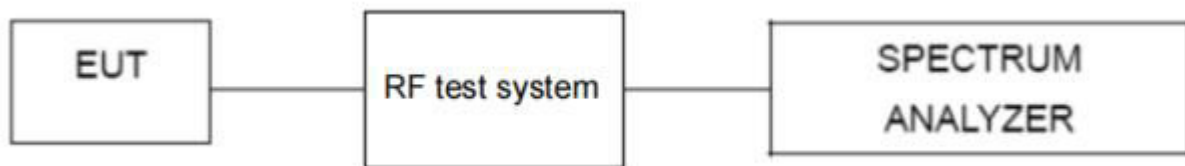

#### 10.2 TEST PROCEDURE

1. Remove the antenna from the EUT and then connect a low RF cable from the antenna port to the spectrum.
2. Set the spectrum analyzer: RBW = 100kHz. VBW = 300kHz. Sweep = auto; Detector Function = Peak. Trace = Max hold.
3. Allow the trace to stabilize. It may prove necessary to break the span up to sections. in order to clearly show all of the hopping frequencies. The limit is specified in one of the subparagraphs of this Section.
4. Set the spectrum analyzer: Start Frequency = 2.4GHz, Stop Frequency = 2.4835GHz. Sweep=auto;

#### 10.3 DEVIATION FROM STANDARD

No deviation.

10.4 TEST RESULT

Modulation	Packet	Hopping Number	Limit	Result
GFSK	1-DH1	79	≥75	Pass
$\pi/4$ -DQPSK	2-DH1	79	≥15	Pass
8-DPSK	3-DH1	79	≥15	Pass

GFSK - 1-DH1 Test Plots

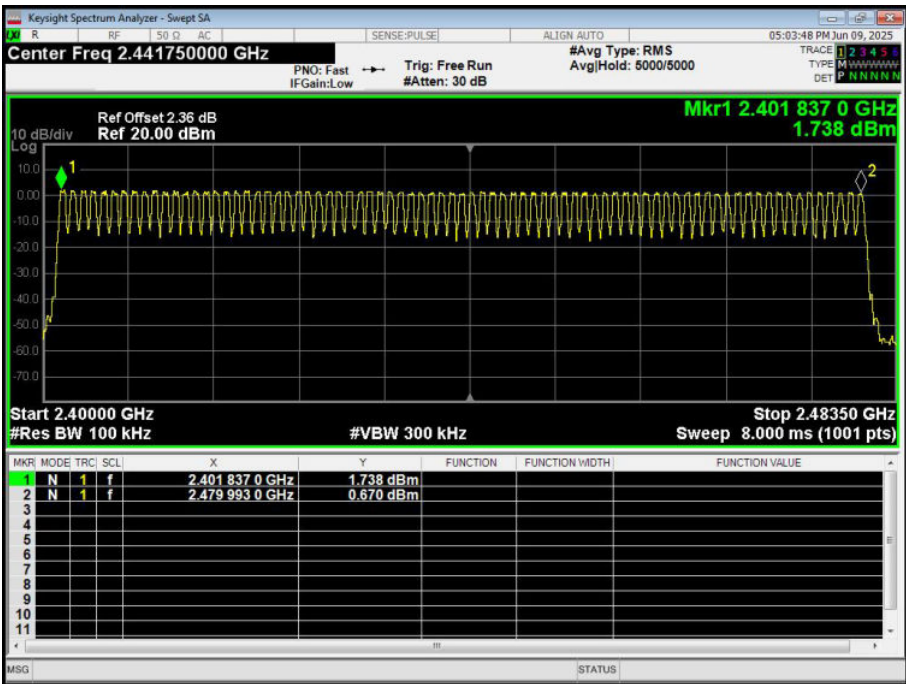

$\pi/4$ -DQPSK - 2-DH1 Test Plots

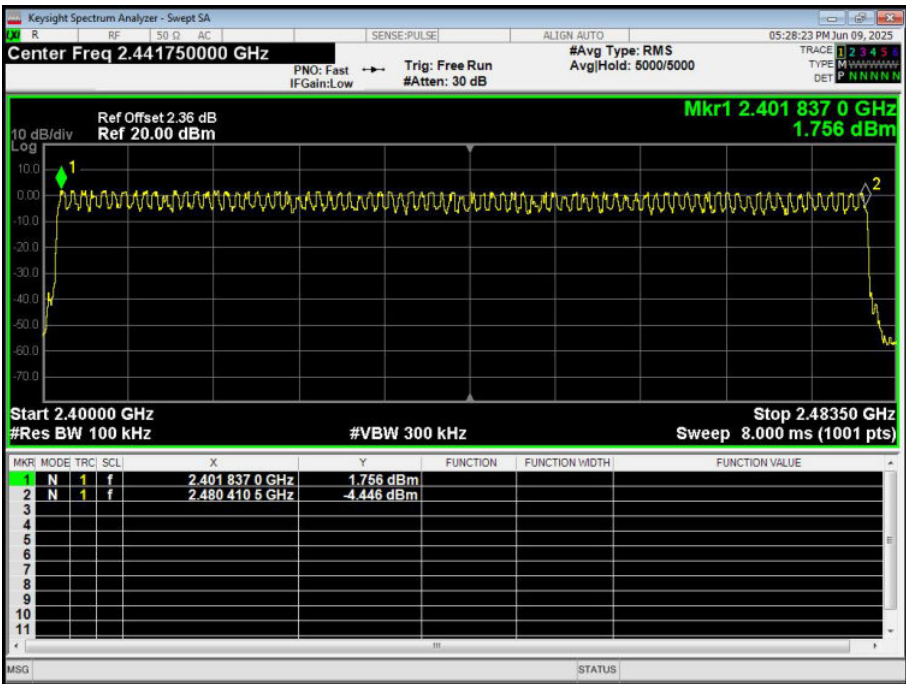



## 11. DWELL TIME

Test Requirement:	FCC Part15 C Section 15.247 (a)(1)(iii)
Test Method:	ANSI C63.10:2013
Receiver setup:	RBW=1MHz, VBW=3MHz, Span=0Hz, Detector=Peak
Limit:	0.4 Second

### 11.1 TEST SETUP



### 11.2 TEST PROCEDURE

1. Remove the antenna from the EUT and then connect a low RF cable from the antenna port to the spectrum.
2. Set spectrum analyzer span = 0 Hz;
3. Set RBW = 1MHz and VBW = 3MHz. Sweep = as necessary to capture the entire dwell time per hopping channel. Set the EUT for DH5, DH3 and DH1 packet transmitting.
4. Use the marker-delta function to determine the dwell time. If this value varies with different modes of operation (e.g.. data rate. modulation format. etc.). repeat this test for each variation. The limit is specified in one of the subparagraphs of this Section. Submit this plot(s).

### 11.3 DEVIATION FROM STANDARD

No deviation.



#### 11.4 TEST RESULT

GFSK mode:

Frequency	Packet	Pulse Time (ms)	Total Dwell Time (ms)	Limit (ms)	Result
2441MHz	1-DH1	0.402	128.640	400	Pass
2441MHz	1-DH3	1.657	265.120	400	Pass
2441MHz	1-DH5	2.906	309.973	400	Pass

Remarks:

The test period:  $T = 0.4 \text{ Second/Channel} \times 79 \text{ Channel} = 31.6 \text{ s}$   
 Test channel: as blow  
 CH:2441MHz time slot= $0.402(\text{ms}) \times (1600 / (2 \times 79)) \times 31.6 = 128.640\text{ms}$   
 CH:2441MHz time slot= $1.657(\text{ms}) \times (1600 / (4 \times 79)) \times 31.6 = 265.120\text{ms}$   
 CH:2441MHz time slot= $2.906(\text{ms}) \times (1600 / (6 \times 79)) \times 31.6 = 309.973\text{ms}$

$\pi/4$ -DQPSK mode:

Frequency	Packet	Pulse Time (ms)	Total Dwell Time (ms)	Limit (ms)	Result
2441MHz	2-DH1	0.411	131.520	400	Pass
2441MHz	2-DH3	1.662	265.920	400	Pass
2441MHz	2-DH5	2.910	310.400	400	Pass

Remarks:

The test period:  $T = 0.4 \text{ Second/Channel} \times 79 \text{ Channel} = 31.6 \text{ s}$   
 Test channel: as blow  
 CH:2441MHz time slot= $0.411(\text{ms}) \times (1600 / (2 \times 79)) \times 31.6 = 131.520\text{ms}$   
 CH:2441MHz time slot= $1.662(\text{ms}) \times (1600 / (4 \times 79)) \times 31.6 = 265.920\text{ms}$   
 CH:2441MHz time slot= $2.910(\text{ms}) \times (1600 / (6 \times 79)) \times 31.6 = 310.400\text{ms}$

8-DPSK mode:

Frequency	Packet	Pulse Time (ms)	Total Dwell Time (ms)	Limit (ms)	Result
2441MHz	3-DH1	0.413	132.160	400	Pass
2441MHz	3-DH3	1.663	266.080	400	Pass
2441MHz	3-DH5	2.914	310.827	400	Pass

Remarks:

The test period:  $T = 0.4 \text{ Second/Channel} \times 79 \text{ Channel} = 31.6 \text{ s}$   
 Test channel: as blow  
 CH:2441MHz time slot= $0.413(\text{ms}) \times (1600 / (2 \times 79)) \times 31.6 = 132.160\text{ms}$   
 CH:2441MHz time slot= $1.663(\text{ms}) \times (1600 / (4 \times 79)) \times 31.6 = 266.080\text{ms}$   
 CH:2441MHz time slot= $2.914(\text{ms}) \times (1600 / (6 \times 79)) \times 31.6 = 310.827\text{ms}$

GFSK Test Plots  
 1-DH1 Middle Channel

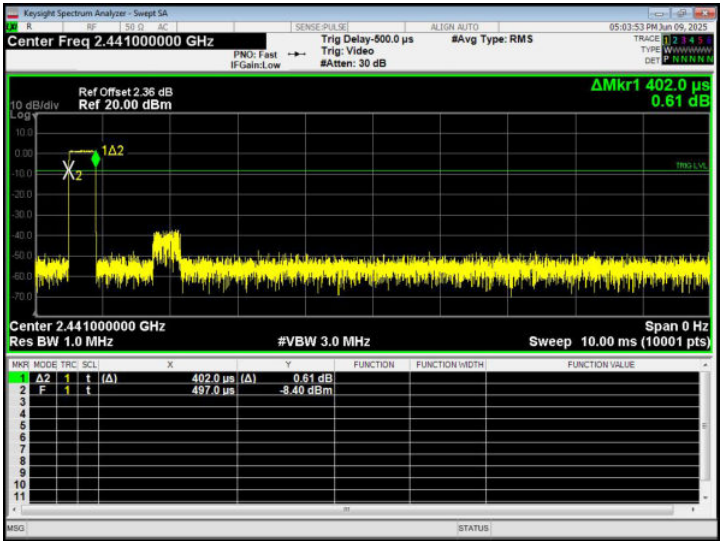

1-DH3 Middle Channel

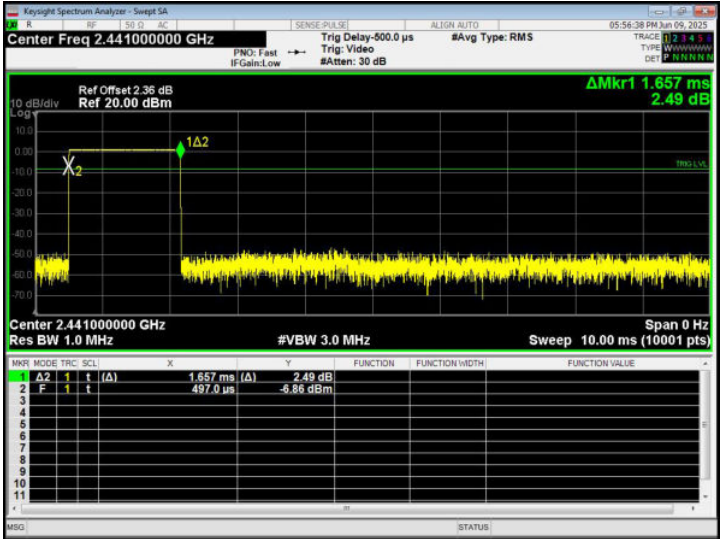

1-DH5 Middle Channel

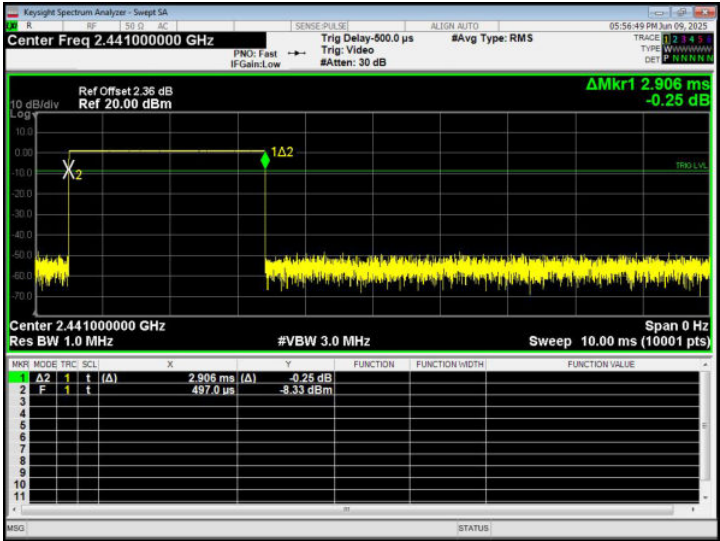

$\pi/4$ -DQPSK Test Plots  
 2-DH1 Middle Channel

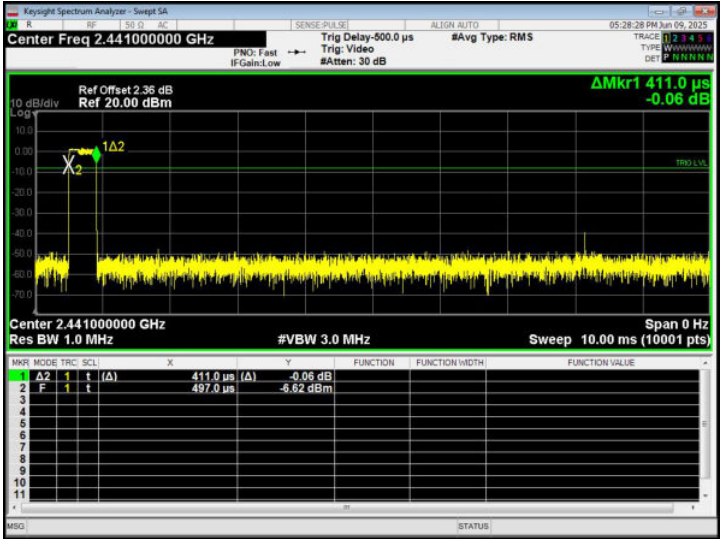

2-DH3 Middle Channel

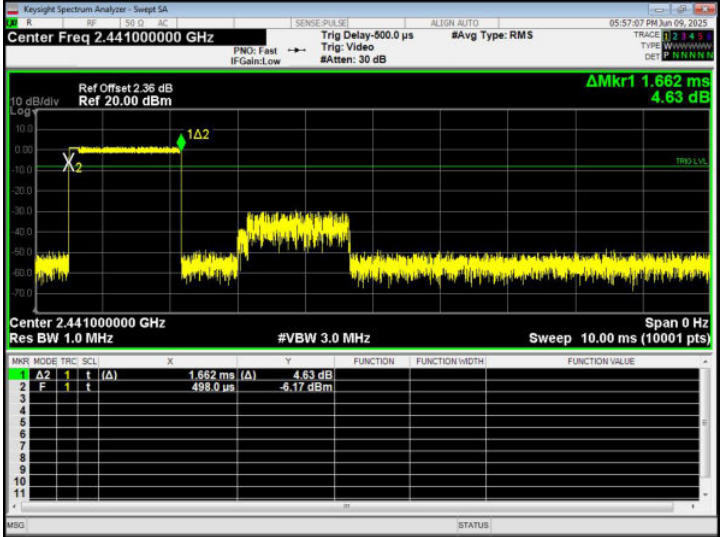

2-DH5 Middle Channel

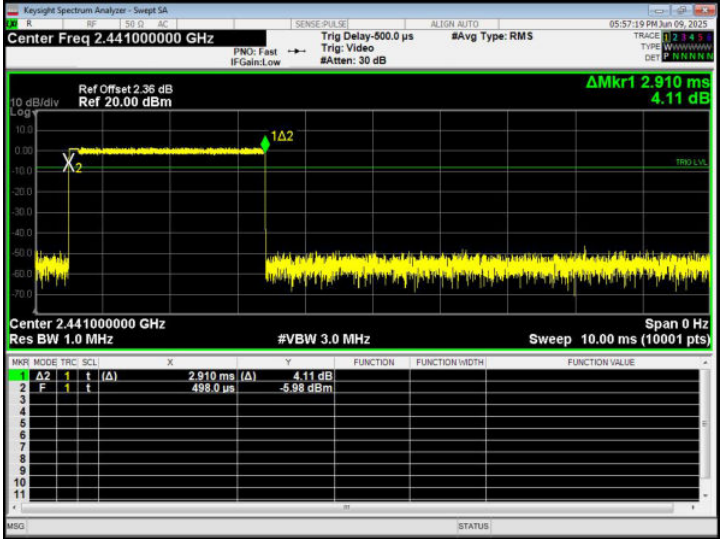

8-DPSK Test Plots  
 3-DH1 Middle Channel

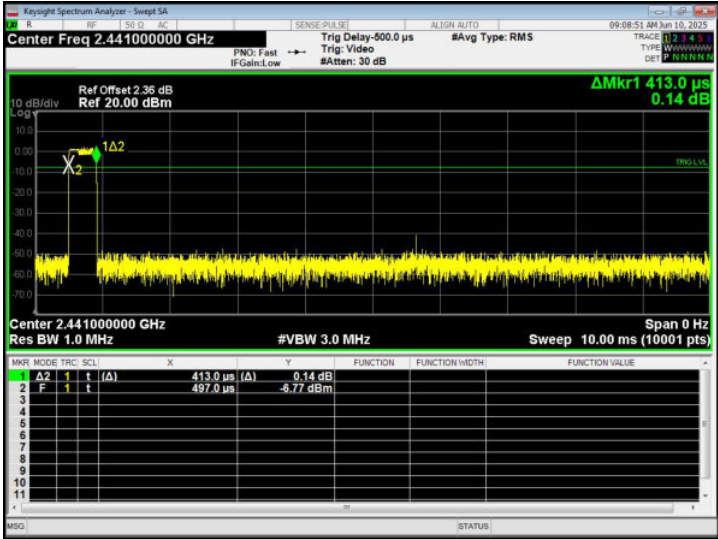

3-DH3 Middle Channel

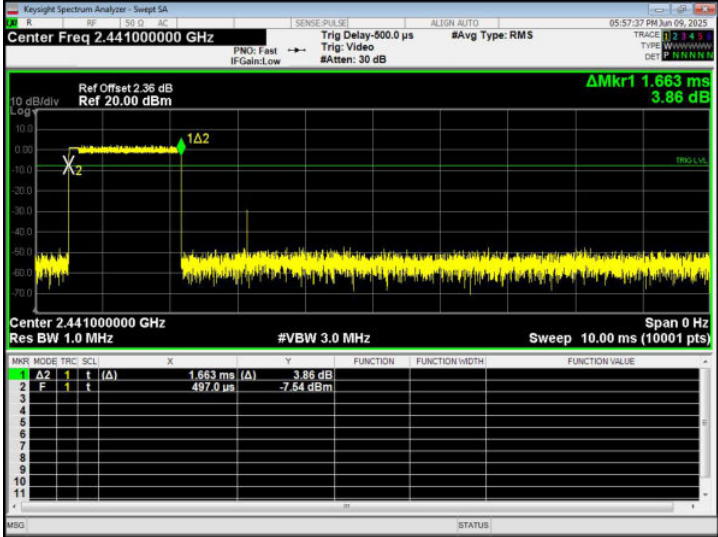

3-DH5 Middle Channel

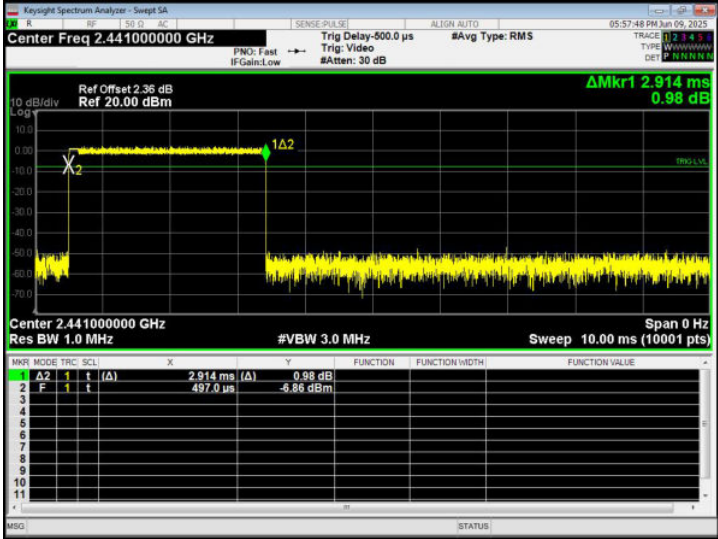

## 12. ANTENNA REQUIREMENT

Standard requirement:	FCC Part15 C Section 15.203 /247(c)
15.203 requirement: An intentional radiator shall be designed to ensure that no antenna other than that furnished by the responsible party shall be used with the device. The use of a permanently attached antenna or of an antenna that uses a unique coupling to the intentional radiator, the manufacturer may design the unit so that a broken antenna can be replaced by the user, but the use of a standard antenna jack or electrical connector is prohibited.	
15.247(c) (1)(i) requirement: (i) Systems operating in the 2400-2483.5 MHz band that is used exclusively for fixed. Point-to-point operations may employ transmitting antennas with directional gain greater than 6dBi provided the maximum conducted output power of the intentional radiator is reduced by 1 dB for every 3 dB that the directional gain of the antenna exceeds 6dBi.	
EUT Antenna:	
The antenna is PCB Antenna, the best case gain of the antennas is 0.93dBi, reference to the appendix II for details.	

### **13. TEST SETUP PHOTO**

Reference to the appendix I for details.

### **14. EUT CONSTRUCTIONAL DETAILS**

Reference to the appendix II for details.

**\*\*\*\*\* END OF REPORT \*\*\*\*\***