

TEST REPORT

Product Name : Mini PC
Model Number : M1 Pro-285H, M1 Pro-*****(* =
“0-9”、“A-Z”、“-”、“blank”)
FCC ID : 2A49R-M1PRO

Prepared for : MICRO COMPUTER (HK) TECH LIMITED
Address : RM 18, 28/F, Shui On Centre · 6-8 Harbour Road ·
Waterfront · Wan Chai · HK

Prepared by : EMTEK (SHENZHEN) CO., LTD.
Address : Bldg 69, Majialong Industry Zone, Nanshan District,
Shenzhen, Guangdong, China

Tel: (0755) 26954280
Fax: (0755) 26954282

Report Number : ENS2505220290W00504R
Date(s) of Tests : May 28, 2025 to June 16, 2025
Date of Issue : June 19, 2025

TABLE OF CONTENTS

1 TEST RESULT CERTIFICATION	4
2 EUT TECHNICAL DESCRIPTION.....	5
3 SUMMARY OF TEST RESULT.....	8
4 TEST METHODOLOGY.....	9
4.1 GENERAL DESCRIPTION OF APPLIED STANDARDS	9
4.2 MEASUREMENT EQUIPMENT USED.....	9
4.3 DESCRIPTION OF TEST MODES	10
5 FACILITIES AND ACCREDITATIONS.....	14
5.1 EQUIPMENT	14
5.2 LABORATORY ACCREDITATIONS AND LISTINGS	14
6 TEST SYSTEM UNCERTAINTY.....	15
7 SETUP OF EQUIPMENT UNDER TEST	16
7.1 RADIO FREQUENCY TEST SETUP	16
7.2 RADIO FREQUENCY TEST SETUP	16
7.3 CONDUCTED EMISSION TEST SETUP	18
7.4 BLOCK DIAGRAM CONFIGURATION OF TEST SYSTEM	19
7.5 SUPPORT EQUIPMENT	19
8 TEST REQUIREMENTS	20
8.1 BANDWIDTH MEASUREMENT	20
8.2 MAXIMUM CONDUCTED OUTPUT POWER	23
8.3 MAXIMUM PEAK POWER DENSITY	25
8.4 UNDESIRABLE RADIATED SPURIOUS EMISSION	28
8.5 POWER LINE CONDUCTED EMISSIONS.....	57
8.6 ANTENNA APPLICATION	60

Modified Information

Version	Report No.	Revision Date	Summary
Ver.1.0	ENS2505220290W00504R	/	Original Report



1 TEST RESULT CERTIFICATION

Applicant : MICRO COMPUTER (HK) TECH LIMITED
 Address : RM 18, 28/F, Shui On Centre · 6-8 Harbour Road · Waterfront · Wan Chai · HK
 Manufacturer : MICRO COMPUTER (HK) TECH LIMITED
 Address : RM 18, 28/F, Shui On Centre · 6-8 Harbour Road · Waterfront · Wan Chai · HK
 EUT : Mini PC
 Model Name : M1 Pro-285H, M1 Pro-*****(* = "0-9" 、" A-Z" 、 "-" 、" blank")
 Trademark : N/A

Measurement Procedure Used:

APPLICABLE STANDARDS	
STANDARD	TEST RESULT
FCC 47 CFR Part 2, Subpart J FCC 47 CFR Part 15, Subpart E	PASS

The above equipment was tested by EMTEK (SHENZHEN) CO., LTD. The test data, data evaluation, test procedures, and equipment configurations shown in this report were made in accordance with the procedures given in ANSI C63.10 (2013) and the energy emitted by the sample EUT tested as described in this report is in compliance with the above table standards requirement.

The test results of this report relate only to the tested sample identified in this report.

Date of Test : May 28, 2025 to June 16, 2025

Prepared by : Una Yu
Una Yu/Editor

Reviewer : Joe Xia
Joe Xia/Supervisor

Approved & Authorized Signer : Lisa Wang
Lisa Wang/Manager



2 EUT TECHNICAL DESCRIPTION

Product Name:	Mini PC
Model Number:	M1 Pro-285H, M1 Pro-*****(* = "0-9" 、" A-Z" 、 "-" 、" blank")
WIFI Type:	UNII-1: 5150MHz-5250MHz Band UNII-2A: 5250MHz-5350MHz Band UNII-2C: 5470MHz-5725MHz Band UNII-3: 5725MHz-5850MHz Band
WLAN Supported:	IEEE 802.11a IEEE 802.11n(20MHz channel bandwidth) IEEE 802.11n(40MHz channel bandwidth) IEEE 802.11ac(20MHz channel bandwidth) IEEE 802.11ac(40MHz channel bandwidth) IEEE 802.11ac(80MHz channel bandwidth) IEEE 802.11ac(160MHz channel bandwidth) IEEE 802.11ax(20MHz channel bandwidth) IEEE 802.11ax(40MHz channel bandwidth) IEEE 802.11ax(80MHz channel bandwidth) IEEE 802.11ax(160MHz channel bandwidth) IEEE 802.11be(20MHz channel bandwidth) IEEE 802.11be(40MHz channel bandwidth) IEEE 802.11be(80MHz channel bandwidth) IEEE 802.11be(160MHz channel bandwidth)
Frequency Range:	5150MHz-5250MHz Band: 5180-5240MHz for 802.11a 5180-5240MHz for 802.11n(20) 5190-5230MHz for 802.11n(40) 5180-5240MHz for 802.11ac(20) 5190-5230MHz for 802.11ac(40) 5210MHz for 802.11ac(80) 5180-5240MHz for 802.11ax(20) 5190-5230MHz for 802.11ax(40) 5210MHz for 802.11ax(80) 5180-5240MHz for 802.11be(20) 5190-5230MHz for 802.11be(40) 5210MHz for 802.11be(80) 5250MHz-5350MHz Band: 5260-5320MHz for 802.11a 5260-5320MHz for 802.11n(20) 5270-5310MHz for 802.11n(40) 5260-5320MHz for 802.11ac(20) 5270-5310MHz for 802.11ac(40) 5290MHz for 802.11ac(80) 5250MHz for 802.11ac(160) 5260-5320MHz for 802.11ax(20) 5270-5310MHz for 802.11ax(40) 5290MHz for 802.11ax(80) 5250MHz for 802.11ax(160) 5260-5320MHz for 802.11be(20)

	<p>5270-5310MHz for 802.11be(40) 5290MHz for 802.11be(80) 5250MHz for 802.11be(160)</p>
	<p>5470MHz-5725MHz Band:</p> <p>5500-5700MHz for 802.11a 5500-5700MHz for 802.11n(20) 5510-5670MHz for 802.11n(40) 5500-5700MHz for 802.11ac(20) 5510-5670MHz for 802.11ac(40) 5530-5610MHz for 802.11ac(80) 5570MHz for 802.11ac(160) 5500-5700MHz for 802.11ax(20) 5510-5670MHz for 802.11ax(40) 5530-5610MHz for 802.11ax(80) 5570MHz for 802.11ax(160) 5500-5700MHz for 802.11be(20) 5510-5670MHz for 802.11be(40) 5530-5610MHz for 802.11be(80) 5570MHz for 802.11be(160)</p>
	<p>5725MHz-5850MHz Band:</p> <p>5745-5825MHz for 802.11a 5745-5825MHz for 802.11n(20) 5755-5795MHz for 802.11n(40) 5745-5825MHz for 802.11ac(20) 5755-5795MHz for 802.11ac(40) 5775MHz for 802.11ac(80) 5745-5825MHz for 802.11ax(20) 5755-5795MHz for 802.11ax(40) 5775MHz for 802.11ax(80) 5745-5825MHz for 802.11be(20) 5755-5795MHz for 802.11be(40) 5775MHz for 802.11be(80)</p>
Modulation:	OFDM/OFDMA
Channel Puncturing:	80 MHz punctured by 20 MHz 160 MHz punctured by 20 MHz 160 MHz punctured by 40 MHz
TPC Function:	Not Support
Beamforming:	Not Support
DFS Function:	Slave
Antenna Type:	FPC Antenna
Antenna Gain:	Ant1: 0.89dBi, Ant2: 2.75dBi (Note: The antenna information is provided by the customers, which will have a certain impact on the test results.)
Smart System:	MIMO

Power Supply:	DC 19V from adapter Input: AC 100-240V~2.5A 50/60HZ
Temperature Range:	0°C ~ +35°C

Note: for more details, please refer to the user's manual of the EUT.



3 SUMMARY OF TEST RESULT

FCC Part Clause	Test Parameter	Verdict	Remark
15.407 (a) 15.407 (e)	99% , 6dB and 26dB Bandwidth	PASS	*
15.407 (a)	Maximum Conducted Output Power	PASS	*
15.407 (a)	Peak Power Spectral Density	PASS	*
15.407 (b)	Radiated Spurious Emission	PASS	
15.407 (b)(6) 15.207	Power Line Conducted Emission	PASS	
15.407(a) 15.203	Antenna Application	PASS	
<p>NOTE1: The results of this report do not take into account the uncertainty. NOTE2: According to FCC OET KDB 789033 D2 General UNII Test Procedures New Rules v02r01, In addition, the radiated test is also performed to ensure the emissions emanating from the device cabinet also comply with the applicable limits. NOTE3: * means that this item refers to module report 230523-08.TR10, 230523-08.TR15, 230523-08.TR17, 230523-08.TR18 of FCC ID: PD9BE200NG</p>			

RELATED SUBMITTAL(S) / GRANT(S):

This submittal(s) (test report) is filing to comply with the above table standards requirement.

4 TEST METHODOLOGY

4.1 GENERAL DESCRIPTION OF APPLIED STANDARDS

According to its specifications, the EUT must comply with the requirements of the following standards:

FCC 47 CFR Part 2, Subpart J

FCC 47 CFR Part 15, Subpart E

FCC KDB 789033 D2 General UNII Test Procedures New Rules v02r01

4.2 MEASUREMENT EQUIPMENT USED

For Conducted Emission Test

Equipment	Manufacturer	Model No.	Serial No.	Last Cal.	Cal. Interval
EMI Test Receiver	Rohde & Schwarz	ESCI	101384	2025/5/9	1Year
AMN	Rohde & Schwarz	ENV216	101161	2025/5/9	1Year

For Spurious Emissions Test

Equipment	Manufacturer	Model No.	Serial No.	Last Cal.	Cal. Interval
Pre-Amplifier	Bonn	BLMA 011001N	2213967A	2024/10/18	1Year
EMI Test Receiver	Rohde & Schwarz	ESR7	102551	2024/10/18	1Year
Bilog Antenna	Schwarzbeck	VULB9163	9163142	2024/7/8	2Year
Horn antenna	Schwarzbeck	BBHA9120D	9120D-1198	2025/5/13	2Year
Pre-Amplifier	Bonn	BLMA 0118-5G	2213967B-01	2024/10/18	1Year
Spectrum Analyzer	Rohde & Schwarz	FSV3044	101290	2024/10/18	1Year
Horn antenna	Schwarzbeck	BBHA9170	9170-399	2025/5/13	2Year
Pre-Amplifier	Lunar EM	LNA18G26-40	J1012131010 001	2025/5/9	1Year
Pre-Amplifier	Lunar EM	LNA26G40-40	J1013131028 001	2025/5/9	1Year
Loop Antenna	Schwarzbeck	FMZB1519	1519-012	2025/5/13	2Year
Wideband Radio Communication Tester	R&S	CMW500	171168	2025/5/9	1Year

For Other Test

Equipment	Manufacturer	Model No.	Serial No.	Last Cal.	Cal. Interval
Wideband Radio Communication Tester	R&S	CMW500	171168	2024/9/18	1Year
Frequency Extender	R&S	CMW-Z800A	100430	2024/9/18	1Year
Spectrum Analyzer	R&S	FSV3044	101289	2024/12/17	1Year
Analog Signal Generator	R&S	SMB100A	183237	2024/9/18	1Year
Vector Signal Generator	R&S	SMM100A	101808	2024/9/18	1Year
RF Control Unit(Power Meter)	Tonscend	JS0806-2	22C8060567	2024/9/18	1Year
Temperature&Hum idity Chamber	ESPEC	EL-02KA	12107166	2025/5/10	1 Year

4.3 DESCRIPTION OF TEST MODES

The EUT has been tested under its typical operating condition.

The EUT configuration for testing is installed on RF field strength measurement to meet the Commissions requirement and operating in a manner which intends to maximize its emission characteristics in a continuous normal application.

The Transmitter was operated in the normal operating mode. The TX frequency was fixed which was for the purpose of the measurements.

Test of channel included the lowest and middle and highest frequency to perform the test, then record on this report.

Pre-defined engineering program for regulatory testing used to control the EUT for staying in continuous transmitting and receiving mode is programmed.

Wifi 5G with 5150-5250MHz

Frequency and Channels list for 802.11a/n(20)/ac(20)/ax(20)/be(20):

Channel	Frequency (MHz)	Channel	Frequency (MHz)	Channel	Frequency (MHz)
36	5180	44	5220	-	-
40	5200	48	5240	-	-

Frequency and Channels list for 802.11n (40)/ac(40)/ax(40)/be(40):

Channel	Frequency (MHz)	Channel	Frequency (MHz)	Channel	Frequency (MHz)
38	5190	-	-	-	-
46	5230	-	-	-	-

Frequency and Channel list for 802.11ac(80)/ax(80)/be(80):

Channel	Frequency (MHz)	Channel	Frequency (MHz)	Channel	Frequency (MHz)
42	5210	-	-	-	-

Test Frequency and Channels for 802.11a/n(20)/ac(20)/ax(20)/be(20):

Lowest Frequency		Middle Frequency		Highest Frequency	
Channel	Frequency (MHz)	Channel	Frequency (MHz)	Channel	Frequency (MHz)
36	5180	40	5200	48	5240

Test Frequency and channels for 802.11n (40)/ac(40)/ax(40)/be(40):

Lowest Frequency		Middle Frequency		Highest Frequency	
Channel	Frequency (MHz)	Channel	Frequency (MHz)	Channel	Frequency (MHz)
38	5190	-	-	46	5230

Test Frequency and channels for 802.11ac(80)/ax(80)/be(80):

Lowest Frequency		Middle Frequency		Highest Frequency	
Channel	Frequency (MHz)	Channel	Frequency (MHz)	Channel	Frequency (MHz)
42	5210	-	-	-	-

WIFI 5G with 5250-5350MHz

Frequency and Channels list for 802.11a/n(20)/ac(20)/ax(20)/be(20):

Channel	Frequency (MHz)	Channel	Frequency (MHz)	Channel	Frequency (MHz)
52	5260	60	5300	-	-
56	5280	64	5320	-	-

Frequency and Channels list for 802.11n (40)/ac(40)/ax(40)/be(40):

Channel	Frequency (MHz)	Channel	Frequency (MHz)	Channel	Frequency (MHz)
54	5270	-	-	-	-
62	5310	-	-	-	-

Frequency and Channels list for 802.11ac(80)/ax(80)/be(80):

Channel	Frequency (MHz)	Channel	Frequency (MHz)	Channel	Frequency (MHz)
58	5290	-	-	-	-

Frequency and Channels list for 802.11ax(160)/be(160):

Channel	Frequency (MHz)	Channel	Frequency (MHz)	Channel	Frequency (MHz)
50	5250	-	-	-	-

Test Frequency and Channels for 802.11a/n(20)/ac(20)/ax(20)/be(20):

Lowest Frequency		Middle Frequency		Highest Frequency	
Channel	Frequency (MHz)	Channel	Frequency (MHz)	Channel	Frequency (MHz)
52	5260	56	5280	64	5320

Test Frequency and channels for 802.11n (40)/ac(40)/ax(40)/be(40):

Lowest Frequency		Middle Frequency		Highest Frequency	
Channel	Frequency (MHz)	Channel	Frequency (MHz)	Channel	Frequency (MHz)
54	5270	-	-	62	5310

Test Frequency and channels for 802.11ac(80)/ax(80)/be(80):

Lowest Frequency		Middle Frequency		Highest Frequency	
Channel	Frequency (MHz)	Channel	Frequency (MHz)	Channel	Frequency (MHz)
58	5290	-	-	-	-

Test Frequency and channels for 802.11ac(160)/ax(160)/be(160):

Channel	Frequency (MHz)	Channel	Frequency (MHz)	Channel	Frequency (MHz)
50	5250	-	-	-	-

WIFI 5G with 5470-5725MHz

Frequency and Channels list for 802.11a/n(20)/ac(20)/ax(20)/be(20):

Channel	Frequency (MHz)	Channel	Frequency (MHz)	Channel	Frequency (MHz)
100	5500	116	5580	132	5660
104	5520	120	5600	136	5680
108	5540	124	5620	140	5700
112	5560	128	5640	-	-

Frequency and Channels list for 802.11n(40)/ac(40)/ax(40)/be(40):

Channel	Frequency (MHz)	Channel	Frequency (MHz)	Channel	Frequency (MHz)
102	5510	118	5590	134	5670
110	5550	126	5630	-	-

Frequency and Channels list for 802.11ac(80)/ax(80)/be(80):

Channel	Frequency (MHz)	Channel	Frequency (MHz)	Channel	Frequency (MHz)
106	5530	122	5610	-	-

Frequency and channels for 802.11ac(160)/ax(160)/be(160):

Channel	Frequency (MHz)	Channel	Frequency (MHz)	Channel	Frequency (MHz)
114	5570	-	-	-	-

Test Frequency and Channels for 802.11a/n(20)/ac(20)/ax(20)/be(20):

Lowest Frequency		Middle Frequency		Highest Frequency	
Channel	Frequency (MHz)	Channel	Frequency (MHz)	Channel	Frequency (MHz)
100	5500	116	5580	140	5700

Test Frequency and channels for 802.11n (40)/ac(40)/ax(40)/be(40):

Lowest Frequency		Middle Frequency		Highest Frequency	
Channel	Frequency (MHz)	Channel	Frequency (MHz)	Channel	Frequency (MHz)
102	5510	-	-	134	5670

Test Frequency and channels for 802.11ac(80)/ax(80)/be(80):

Lowest Frequency		Middle Frequency		Highest Frequency	
Channel	Frequency (MHz)	Channel	Frequency (MHz)	Channel	Frequency (MHz)
106	5530	122	5610	-	-

Test Frequency and channels for 802.11ac(160)/ax(160)/be(160):

Channel	Frequency (MHz)	Channel	Frequency (MHz)	Channel	Frequency (MHz)
114	5570	-	-	-	-

Wifi 5G with 5725MHz-5850MHz

Frequency and Channels list for 802.11a/n(20)/802.11ac(20)/ax(20)/be(20):

Channel	Frequency (MHz)	Channel	Frequency (MHz)	Channel	Frequency (MHz)
149	5745	157	5785	165	5825
153	5765	161	5805	-	-

Frequency and Channels list for 802.11n(40)/ac(40)/ax(40)/be(40):

Channel	Frequency (MHz)	Channel	Frequency (MHz)	Channel	Frequency (MHz)
151	5755	-	-	-	-
159	5795	-	-	-	-

Frequency and Channels list for 802.11ac(80)/ax(80)/be(80):

Channel	Frequency (MHz)	Channel	Frequency (MHz)	Channel	Frequency (MHz)
155	5775	-	-	-	-

Test Frequency and Channels for 802.11a/n(20)/ac(20)/ax(20)/be(20):

Lowest Frequency		Middle Frequency		Highest Frequency	
Channel	Frequency (MHz)	Channel	Frequency (MHz)	Channel	Frequency (MHz)
149	5745	157	5785	165	5825

Test Frequency and channels for 802.11n(40)/ac(40)/ax(40)/be(40):

Lowest Frequency		Middle Frequency		Highest Frequency	
Channel	Frequency (MHz)	Channel	Frequency (MHz)	Channel	Frequency (MHz)
151	5755	-	-	159	5795

Test Frequency and channels for 802.11ac(80)/ax(80)/be(80):

Lowest Frequency		Middle Frequency		Highest Frequency	
Channel	Frequency (MHz)	Channel	Frequency (MHz)	Channel	Frequency (MHz)
155	5775	-	-	-	-

Multi-antenna correlation:

<input checked="" type="checkbox"/>	Transmit Signals are Correlated
	Directional gain = $10 \log[(10^{G^1/20} + 10^{G^2/20} + \dots + 10^{G^N/20})^2 / N_{ANT}]$ dBi
<input type="checkbox"/>	All Transmit Signals are Completely Uncorrelated
	Directional gain = $10 \log[(10^{G^1/10} + 10^{G^2/10} + \dots + 10^{G^N/10}) / N_{ANT}]$ dBi

Ant1: 0.89dBi, Ant2: 2.75dBi

Directional gain = 4.88dBi

5 FACILITIES AND ACCREDITATIONS

5.1 EQUIPMENT

Radiated emissions are measured with one or more of the following types of linearly polarized antennas: tuned dipole, biconical, log periodic, bi-log, and/or ridged wave guide, horn. Spectrum analyzers with preselectors and quasi-peak detectors are used to perform radiated measurements.

Conducted emissions are measured with Line Impedance Stabilization Networks and EMI Test Receivers.

Calibrated wide band preamplifiers, coaxial cables, and coaxial attenuators are also used for making measurements.

All receiving equipment conforms to CISPR Publication 16-1, "Radio Interference Measuring Apparatus and Measurement Methods".

5.2 LABORATORY ACCREDITATIONS AND LISTINGS

Site Description

Name of Firm : EMTEK (SHENZHEN) CO., LTD.

Site Location : Building 69, Majialong Industry Zone, Nanshan District, Shenzhen, Guangdong, China

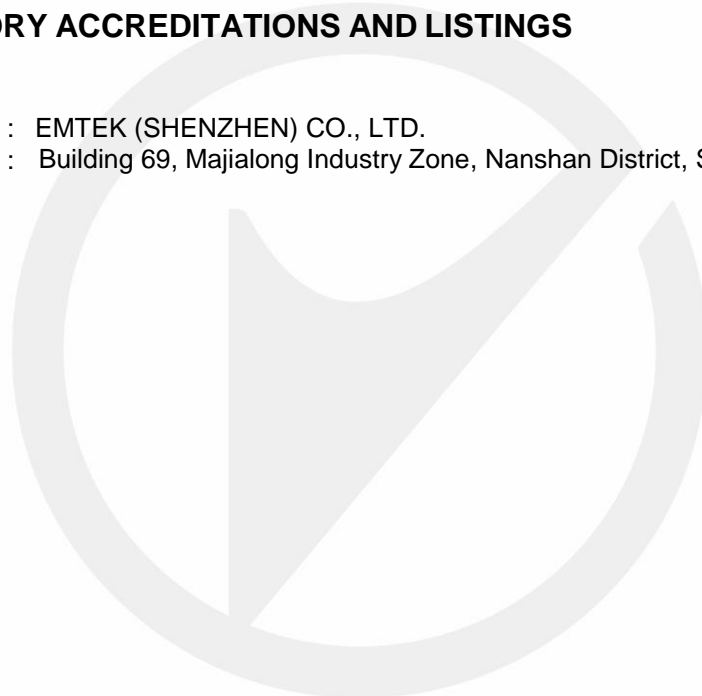

6 TEST SYSTEM UNCERTAINTY

The following measurement uncertainty levels have been estimated for tests performed on the apparatus:

Parameter	Uncertainty
Radio Frequency	$\pm 1 \times 10^{-5}$
Maximum Peak Output Power Test	$\pm 1.0\text{dB}$
Conducted Emissions Test	$\pm 2.0\text{dB}$
Radiated Emission Test	$\pm 2.0\text{dB}$
Power Density	$\pm 2.0\text{dB}$
Occupied Bandwidth Test	$\pm 1.0\text{dB}$
Band Edge Test	$\pm 3\text{dB}$
All emission, radiated	$\pm 3\text{dB}$
Antenna Port Emission	$\pm 3\text{dB}$
Temperature	$\pm 0.5^\circ\text{C}$
Humidity	$\pm 3\%$

Measurement Uncertainty for a level of Confidence of 95%.

7 SETUP OF EQUIPMENT UNDER TEST

7.1 RADIO FREQUENCY TEST SETUP

The WLAN component's antenna ports(s) of the EUT are connected to the measurement instrument per an appropriate attenuator. The EUT is controlled by PC/software to emit the specified signals for the purpose of measurements.

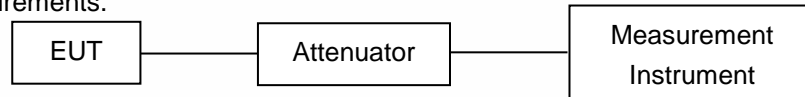

7.2 RADIO FREQUENCY TEST SETUP

The test site semi-anechoic chamber has met the requirement of NSA tolerance 4 dB according to the standards: ANSI C63.10. The test distance is 3m. The setup is according to the requirements in Section 13.1.4.1 of ANSI C63.10-2013 and CAN/CSA-CEI/IEC CISPR 22.

Below 30MHz:

The EUT is placed on a turntable 0.8 meters above the ground in the chamber, 3 meter away from the antenna (loop antenna). The Antenna should be positioned with its plane vertical at the specified distance from the EUT and rotated about its vertical axis for maximum response at each azimuth about the EUT. The center of the loop shall be 1 m above the ground. For certain applications, the loop antenna plane may also need to be positioned horizontally at the specified distance from the EUT.

Above 30MHz:

The EUT is placed on a turntable 0.8 meters above the ground in the chamber, 3 meter away from the antenna. The maximal emission value is acquired by adjusting the antenna height, polarisation and turntable azimuth. Normally, the height range of antenna is 1 m to 4 m, the azimuth range of turntable is 0° to 360°, and the receive antenna has two polarizations Vertical (V) and Horizontal (H).

Above 1GHz:

(Note: the FCC's permission to use 1.5m as an alternative per TCBC Conf call of Dec. 2, 2014.)

The EUT is placed on a turntable 1.5 meters above the ground in the chamber, 3 meter away from the antenna. The maximal emission value is acquired by adjusting the antenna height, polarisation and turntable azimuth. Normally, the height range of antenna is 1 m to 4 m, the azimuth range of turntable is 0° to 360°, and the receive antenna has two polarizations Vertical (V) and Horizontal (H).

(a) Radiated Emission Test Set-Up, Frequency Below 30MHz

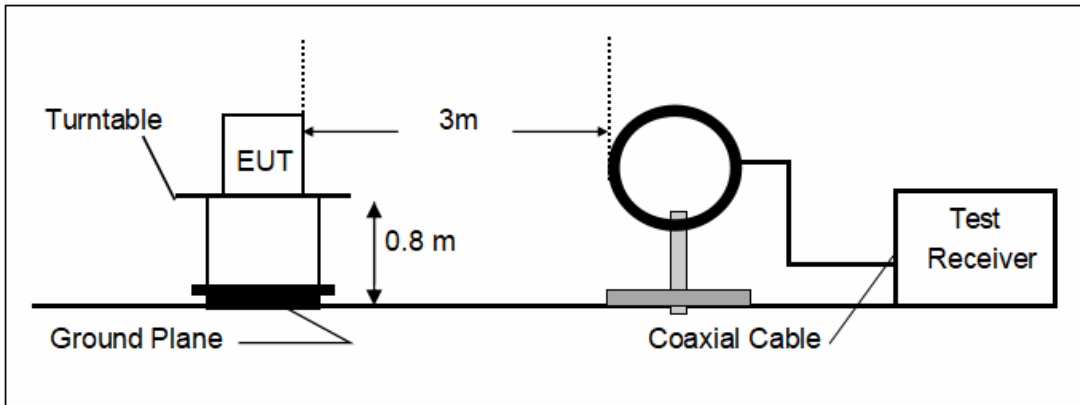

(b) Radiated Emission Test Set-Up, Frequency Below 1000MHz

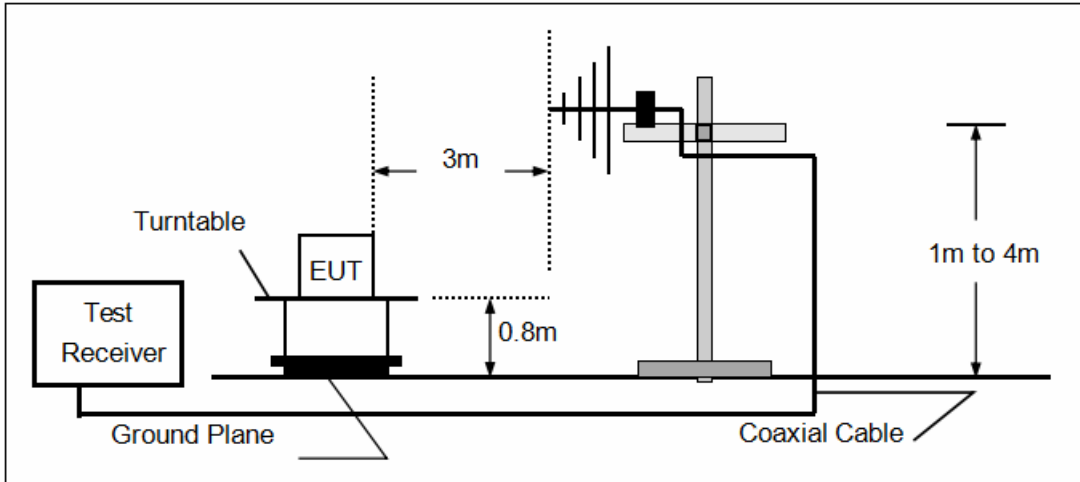

(c) Radiated Emission Test Set-Up, Frequency above 1000MHz

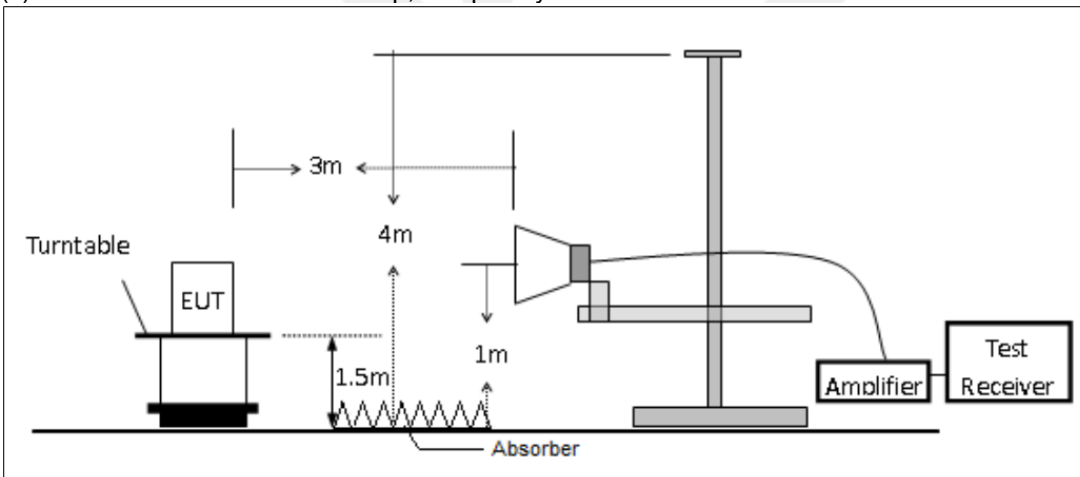

7.3 CONDUCTED EMISSION TEST SETUP

The mains cable of the EUT (maybe per AC/DC Adapter) must be connected to LISN. The LISN shall be placed 0.8 m from the boundary of EUT and bonded to a ground reference plane for LISN mounted on top of the ground reference plane. This distance is between the closest points of the LISN and the EUT. All other units of the EUT and associated equipment shall be at least 0.8m from the LISN.

Ground connections, where required for safety purposes, shall be connected to the reference ground point of the LISN and, where not otherwise provided or specified by the manufacturer, shall be of same length as the mains cable and run parallel to the mains connection at a separation distance of not more than 0.1 m.

According to the requirements in Section 13.1.4.1 of ANSI C63.10-2013 Conducted emissions from the EUT measured in the frequency range between 0.15 MHz and 30 MHz using CISPR Quasi-Peak and average detector mode.

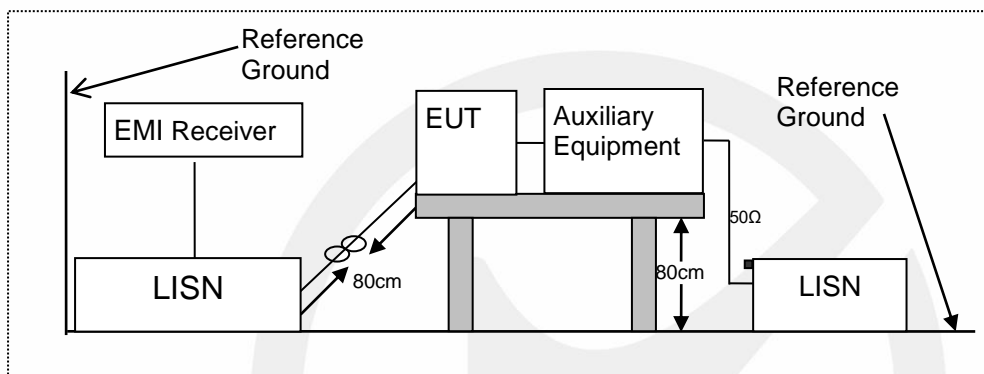

7.4 BLOCK DIAGRAM CONFIGURATION OF TEST SYSTEM

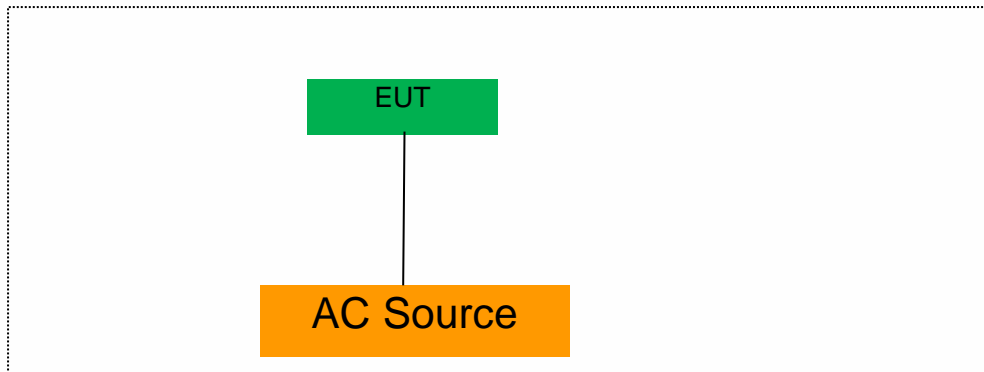

7.5 SUPPORT EQUIPMENT

Adapter: : Model: A20-065N3A
 Input: 100-240V~50/60Hz, 1.6A
 Output: 5V, 3A, 15W; 9V, 3A; 12V, 3A; 15V, 3A; 20V, 3.25A, 65W
 CE, FCC

Notes:

- 1.All the equipment/cables were placed in the worst-case configuration to maximize the emission during the test.
- 2.Grounding was established in accordance with the manufacturer's requirements and conditions for the intended use.

8 TEST REQUIREMENTS

8.1 BANDWIDTH MEASUREMENT

8.1.1 Applicable Standard

According to FCC Part 15.407(a)(1) for UNII Band I
According to FCC Part 15.407(a)(2) for UNII Band II-A and UNII Band II-C
According to FCC Part 15.407(a)(3) for UNII Band III
According to FCC Part 15.407(e) for UNII Band III
According to 789033 D02 Section II(C)
According to 789033 D02 Section II(D)

8.1.2 Conformance Limit

(1) For the band 5.15-5.25 GHz.

(iv) For mobile and portable client devices in the 5.15-5.25 GHz band, the maximum conducted output power over the frequency band of operation shall not exceed 250 mW provided the maximum antenna gain does not exceed 6 dBi. In addition, the maximum power spectral density shall not exceed 11 dBm in any 1 megahertz band. If transmitting antennas of directional gain greater than 6 dBi are used, both the maximum conducted output power and the maximum power spectral density shall be reduced by the amount in dB that the directional gain of the antenna exceeds 6 dBi.

(2) For the 5.25-5.35 GHz and 5.47-5.725 GHz bands, the maximum conducted output power over the frequency bands of operation shall not exceed the lesser of 250 mW or 11 dBm + 10 log B, where B is the 26 dB emission bandwidth in megahertz. In addition, the maximum power spectral density shall not exceed 11 dBm in any 1 megahertz band. If transmitting antennas of directional gain greater than 6 dBi are used, both the maximum conducted output power and the maximum power spectral density shall be reduced by the amount in dB that the directional gain of the antenna exceeds 6 dBi.

(3) For the band 5.725-5.85 GHz, the maximum conducted output power over the frequency band of operation shall not exceed 1 W. In addition, the maximum power spectral density shall not exceed 30 dBm in any 500-kHz band. If transmitting antennas of directional gain greater than 6 dBi are used, both the maximum conducted output power and the maximum power spectral density shall be reduced by the amount in dB that the directional gain of the antenna exceeds 6 dBi. However, fixed point-to-point U-NII devices operating in this band may employ transmitting antennas with directional gain greater than 6 dBi without any corresponding reduction in transmitter conducted power. Fixed, point-to-point operations exclude the use of point-to-multipoint systems, omnidirectional applications, and multiple collocated transmitters transmitting the same information. The operator of the U-NII device, or if the equipment is professionally installed, the installer, is responsible for ensuring that systems employing high gain directional antennas are used exclusively for fixed, point-to-point operations.

(e) Within the 5.725-5.85 GHz band, the minimum 6 dB bandwidth of U-NII devices shall be at least 500 kHz.

8.1.3 Test Configuration

Test according to clause 6.1 radio frequency test setup.

8.1.4 Test Procedure

According to 789033 D02 v02r01 section C&D, the following is the measurement procedure.

1. Emission Bandwidth (EBW)

- a) Set RBW = approximately 1% of the emission bandwidth.
- b) Set the VBW > RBW.
- c) Detector = Peak.
- d) Trace mode = max hold.
- e) Measure the maximum width of the emission that is 26 dB down from the maximum of the emission.

Compare this with the RBW setting of the analyzer. Readjust RBW and repeat measurement as needed until the RBW/EBW ratio is approximately 1%.

2. Minimum Emission Bandwidth for the band 5.725-5.85 GHz

Section 15.407(e) specifies the minimum 6 dB emission bandwidth of at least 500 KHz for the band 5.715-5.85 GHz. The following procedure shall be used for measuring this bandwidth:

- a) Set RBW = 100 kHz.
- b) Set the video bandwidth (VBW) $\geq 3 \times$ RBW.
- c) Detector = Peak.
- d) Trace mode = max hold.
- e) Sweep = auto couple.
- f) Allow the trace to stabilize.
- g) Measure the maximum width of the emission that is constrained by the frequencies associated with the two outermost amplitude points (upper and lower frequencies) that are attenuated by 6 dB relative to the maximum level measured in the fundamental emission.

Note: The automatic bandwidth measurement capability of a spectrum analyzer or EMI receiver may be employed if it implements the functionality described above.

D. 99 Percent Occupied Bandwidth

The 99-percent occupied bandwidth is the frequency bandwidth such that, below its lower and above its upper frequency limits, the mean powers are each equal to 0.5 % of the total mean power of the given emission. Measurement of the 99-percent occupied bandwidth is required only as a condition for using the optional band-edge measurement techniques described in section II.G.3.d). Measurements of 99-percent occupied bandwidth may also optionally be used in lieu of the EBW to 789033 D02 v01r02 General UNII Test Procedures New Rules v01 define the minimum frequency range over which the spectrum is integrated when measuring maximum conducted output power as described in section II.E. However, the EBW must be measured to determine bandwidth dependent limits on maximum conducted output power in accordance with 15.407(a).

The following procedure shall be used for measuring (99 %) power bandwidth:

1. Set center frequency to the nominal EUT channel center frequency.
2. Set span = 1.5 times to 5.0 times the OBW.
3. Set RBW = 1 % to 5 % of the OBW.
4. Set VBW $\geq 3 \times$ RBW.
5. Video averaging is not permitted. Where practical, a sample detection and single sweep mode shall be used. Otherwise, peak detection and max hold mode (until the trace stabilizes) shall be used.
6. Use the 99 % power bandwidth function of the instrument (if available).
7. If the instrument does not have a 99 % power bandwidth function, the trace data points are recovered and directly summed in power units. The recovered amplitude data points, beginning at the lowest frequency, are placed in a running sum until 0.5 % of the total is reached; that frequency is recorded as the lower frequency. The process is repeated until 99.5 % of the total is reached; that frequency is recorded as the upper frequency. The 99% occupied bandwidth is the difference between these two frequencies.

8.1.5 Test Results

Temperature : 25°C
Humidity : 45 %

ATM Pressure:: 1011 mbar
Test Engineer: GJ

Note: Power data reference module report.



8.2 MAXIMUM CONDUCTED OUTPUT POWER

8.2.1 Applicable Standard

According to FCC Part 15.407(a)(1) for UNII Band I

According to FCC Part 15.407(a)(2) for UNII Band II-A and UNII Band II-C

According to FCC Part 15.407(a)(3) for UNII Band III

According to 789033 D02 Section II(E)

8.2.2 Conformance Limit

■ For the band 5.15-5.25 GHz,

(a) (1) (i) For an outdoor access point operating in the band 5.15-5.25 GHz, the maximum conducted output power over the frequency band of operation shall not exceed 1 W provided the maximum antenna gain does not exceed 6 dBi. If transmitting antennas of directional gain greater than 6 dBi are used, both the maximum conducted output power and the maximum power spectral density shall be reduced by the amount in dB that the directional gain of the antenna exceeds 6 dBi. The maximum e.i.r.p. at any elevation angle above 30 degrees as measured from the horizon must not exceed 125 mW (21 dBm).

(a) (1) (ii) For an indoor access point operating in the band 5.15-5.25 GHz, the maximum conducted output power over the frequency band of operation shall not exceed 1 W provided the maximum antenna gain does not exceed 6 dBi. If transmitting antennas of directional gain greater than 6 dBi are used, both the maximum conducted output power and the maximum power spectral density shall be reduced by the amount in dB that the directional gain of the antenna exceeds 6 dBi.

(a) (1) (iii) For fixed point-to-point access points operating in the band 5.15-5.25 GHz, the maximum conducted output power over the frequency band of operation shall not exceed 1 W. Fixed point-to-point U-NII devices may employ antennas with directional gain up to 23 dBi without any corresponding reduction in the maximum conducted output power or maximum power spectral density. For fixed point-to-point transmitters that employ a directional antenna gain greater than 23 dBi, a 1 dB reduction in maximum conducted output power and maximum power spectral density is required for each 1 dB of antenna gain in excess of 23 dBi. Fixed, point-to-point operations exclude the use of point-to-multipoint systems, omnidirectional applications, and multiple collocated transmitters transmitting the same information. The operator of the U-NII device, or if the equipment is professionally installed, the installer, is responsible for ensuring that systems employing high gain directional antennas are used exclusively for fixed, point-to-point operations.

(a) (1) (iv) For mobile and portable client devices in the 5.15-5.25 GHz band, the maximum conducted output power over the frequency band of operation shall not exceed 250 mW provided the maximum antenna gain does not exceed 6 dBi. If transmitting antennas of directional gain greater than 6 dBi are used, both the maximum conducted output power and the maximum power spectral density shall be reduced by the amount in dB that the directional gain of the antenna exceeds 6 dBi.

■ For the 5.25-5.35 GHz and 5.47-5.725 GHz bands

(a) (2) the maximum conducted output power over the frequency bands of operation shall not exceed the lesser of 250 mW or $11 \text{ dBm} + 10 \log B$, where B is the 26 dB emission bandwidth in megahertz. In addition, the maximum power spectral density shall not exceed 11 dBm in any 1 megahertz band. If transmitting antennas of directional gain greater than 6 dBi are used, both the maximum conducted output power and the maximum power spectral density shall be reduced by the amount in dB that the directional gain of the antenna exceeds 6 dBi.

■ For the band 5.725-5.85 GHz

(a) (3) For the band 5.725-5.85 GHz, the maximum conducted output power over the frequency band of operation shall not exceed 1 W. In addition, the maximum power spectral density shall not exceed 30 dBm in any 500-kHz band. If transmitting antennas of directional gain greater than 6 dBi are used, both the maximum conducted output power and the maximum power spectral density shall be reduced by the amount in dB that the directional gain of the antenna exceeds 6 dBi.

8.2.3 Test Configuration

Test according to clause 6.1 radio frequency test setup 1.

8.2.4 Test Procedure

The maximum average conducted output power can be measured using Method PM-G (Measurement using a gated RF average power meter):

Measurements may be performed using a wideband gated RF power meter provided that the gate parameters are adjusted such that the power is measured only when the EUT is transmitting at its maximum power control level. Since the measurement is made only during the ON time of the transmitter, no duty cycle correction factor is required.

- a. The Transmitter output (antenna port) was connected to the power meter.
- b. Turn on the EUT and power meter and then record the power value.
- c. Repeat above procedures on all channels needed to be tested.

8.2.5 Test Results

Temperature : 25°C
Humidity : 60 %

ATM Pressure:: 1011 mbar
Test Engineer: GJ

Note: Power data reference module report.

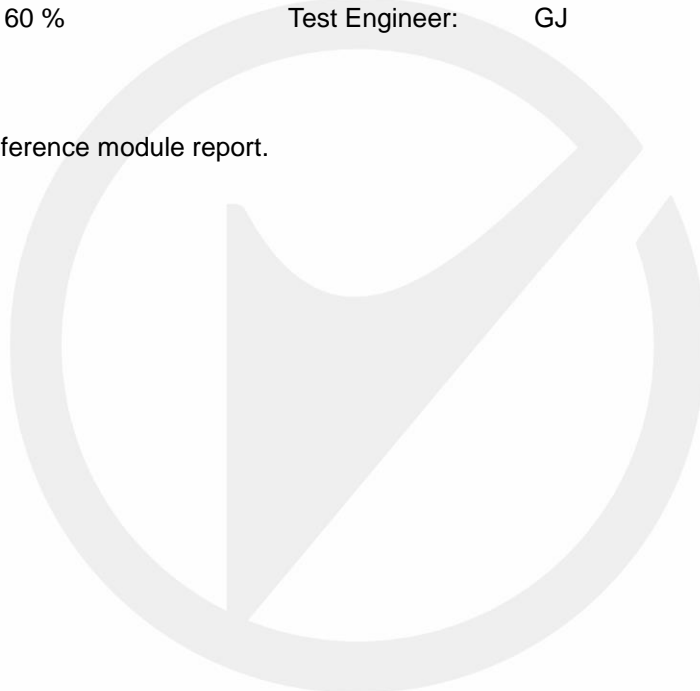

8.3 MAXIMUM PEAK POWER DENSITY

8.3.1 Applicable Standard

According to FCC Part 15.407(a)(1) for UNII Band I

According to FCC Part 15.407(a)(2) for UNII Band II-A and UNII Band II-C

According to FCC Part 15.407(a)(3) for UNII Band III

According to 789033 D02 Section II(F)

8.3.2 Conformance Limit

■ For the band 5.15-5.25 GHz

(a) (1) (i) For an outdoor access point operating in the band 5.15-5.25 GHz, the maximum conducted output power over the frequency band of operation shall not exceed 1 W provided the maximum antenna gain does not exceed 6 dBi. If transmitting antennas of directional gain greater than 6 dBi are used, both the maximum conducted output power and the maximum power spectral density shall be reduced by the amount in dB that the directional gain of the antenna exceeds 6 dBi. The maximum e.i.r.p. at any elevation angle above 30 degrees as measured from the horizon must not exceed 125 mW (21 dBm).

(a) (1) (ii) For an indoor access point operating in the band 5.15-5.25 GHz, the maximum conducted output power over the frequency band of operation shall not exceed 1 W provided the maximum antenna gain does not exceed 6 dBi. If transmitting antennas of directional gain greater than 6 dBi are used, both the maximum conducted output power and the maximum power spectral density shall be reduced by the amount in dB that the directional gain of the antenna exceeds 6 dBi.

(a) (1) (iii) For fixed point-to-point access points operating in the band 5.15-5.25 GHz, the maximum conducted output power over the frequency band of operation shall not exceed 1 W. Fixed point-to-point U-NII devices may employ antennas with directional gain up to 23 dBi without any corresponding reduction in the maximum conducted output power or maximum power spectral density. For fixed point-to-point transmitters that employ a directional antenna gain greater than 23 dBi, a 1 dB reduction in maximum conducted output power and maximum power spectral density is required for each 1 dB of antenna gain in excess of 23 dBi. Fixed, point-to-point operations exclude the use of point-to-multipoint systems, omnidirectional applications, and multiple collocated transmitters transmitting the same information. The operator of the U-NII device, or if the equipment is professionally installed, the installer, is responsible for ensuring that systems employing high gain directional antennas are used exclusively for fixed, point-to-point operations.

(a) (1) (iv) For mobile and portable client devices in the 5.15-5.25 GHz band, the maximum conducted output power over the frequency band of operation shall not exceed 250 mW provided the maximum antenna gain does not exceed 6 dBi. If transmitting antennas of directional gain greater than 6 dBi are used, both the maximum conducted output power and the maximum power spectral density shall be reduced by the amount in dB that the directional gain of the antenna exceeds 6 dBi.

■ For the 5.25-5.35 GHz and 5.47-5.725 GHz

(b) (2) the maximum conducted output power over the frequency bands of operation shall not exceed the lesser of 250 mW or $11 \text{ dBm} + 10 \log B$, where B is the 26 dB emission bandwidth in megahertz. In addition, the maximum power spectral density shall not exceed 11 dBm in any 1 megahertz band. If transmitting antennas of directional gain greater than 6 dBi are used, both the maximum conducted output power and the maximum power spectral density shall be reduced by the amount in dB that the directional gain of the antenna exceeds 6 dBi.

■ For the band 5.725-5.85 GHz

(a) (3) For the band 5.725-5.85 GHz, the maximum conducted output power over the frequency band of operation shall not exceed 1 W. In addition, the maximum power spectral density shall not exceed 30 dBm in any 500-kHz band. If transmitting antennas of directional gain greater than 6 dBi are used, both the maximum conducted output power and the maximum power spectral density shall be reduced by the amount in dB that the directional gain of the antenna exceeds 6 dBi.

8.3.3 Test Configuration

Test according to clause 6.1 radio frequency test setup 1.

8.3.4 Test Procedure

Methods refer to FCC KDB 789033.

For devices operating in the bands 5.15-5.25 GHz, 5.25-5.35 GHz, and 5.47-5.725 GHz, the above procedures make use of 1 MHz RBW to satisfy directly the 1 MHz reference bandwidth specified in § 15.407(a)(5). For devices operating in the band 5.725-5.85 GHz, the rules specify a measurement bandwidth of 500 kHz. Many spectrum analyzers do not have 500 kHz RBW, thus a narrower RBW may need to be used. The rules permit the use of a RBWs less than 1 MHz, or 500 kHz, “provided that the measured power is integrated over the full reference bandwidth” to show the total power over the specified measurement bandwidth (i.e., 1 MHz, or 500 kHz). If measurements are performed using a reduced resolution bandwidth (< 1 MHz, or < 500 kHz) and integrated over 1 MHz, or 500 KHz bandwidth, the following adjustments to the procedures apply:

- a) Set $RBW \geq 1/T$, where T is defined in section II.B.I.a).
- b) Set $VBW \geq 3 RBW$.
- c) If measurement bandwidth of Maximum PSD is specified in 500 kHz, add $10\log(500\text{kHz}/RBW)$ to the measured result, whereas RBW (< 500 KHz) is the reduced resolution bandwidth of the spectrum analyzer set during measurement.
- d) If measurement bandwidth of Maximum PSD is specified in 1 MHz, add $10\log(1\text{MHz}/RBW)$ to the measured result, whereas RBW (< 1 MHz) is the reduced resolution bandwidth of spectrum analyzer set during measurement.
- e) Care must be taken to ensure that the measurements are performed during a period of continuous transmission or are corrected upward for duty cycle.

Note: As a practical matter, it is recommended to use reduced RBW of 100 KHz for the sections.

5.c) and 5.d) above, since RBW=100 KHZ is available on nearly all spectrum analyzers.

8.3.5 Test Results

Temperature : 25°C
Humidity : 60 %

ATM Pressure:: 1011 mbar
Test Engineer: GJ

Note: Power data reference module report.



8.4 UNDESIRABLE RADIATED SPURIOUS EMISSION

8.4.1 Applicable Standard

According to FCC Part 15.407 (b)
According to 789033 D02 Section II(G)

8.4.2 Conformance Limit

For transmitters operating in the 5.15-5.25 GHz band: All emissions outside of the 5.15-5.35 GHz band shall not exceed an e.i.r.p. of -27 dBm/MHz.

For transmitters operating in the 5.25-5.35 GHz band: All emissions outside of the 5.15-5.35 GHz band shall not exceed an e.i.r.p. of -27 dBm/MHz.

For transmitters operating in the 5.47-5.725 GHz band: All emissions outside of the 5.47-5.725 GHz band shall not exceed an e.i.r.p. of -27 dBm/MHz.

For transmitters operating in the 5.725-5.85 GHz band: All emissions shall be limited to a level of -27 dBm/MHz at 75 MHz or more above or below the band edge increasing linearly to 10 dBm/MHz at 25 MHz above or below the band edge, and from 25 MHz above or below the band edge increasing linearly to a level of 15.6 dBm/MHz at 5 MHz above or below the band edge, and from 5 MHz above or below the band edge increasing linearly to a level of 27 dBm/MHz at the band edge.

The emission measurements shall be performed using a minimum resolution bandwidth of 1 MHz. A lower resolution bandwidth may be employed near the band edge, when necessary, provided the measured energy is integrated to show the total power over 1 MHz.

Unwanted emissions below 1 GHz must comply with the general field strength limits set forth in §15.209.

The emissions from an intentional radiator shall not exceed the field strength levels specified in the following table 15.209(a):

Restricted Frequency(MHz)	Field Strength ($\mu\text{V}/\text{m}$)	Field Strength ($\text{dB}\mu\text{V}/\text{m}$)	Measurement Distance
0.009-0.490	2400/F(KHz)	20 log (uV/m)	300
0.490-1.705	2400/F(KHz)	20 log (uV/m)	30
1.705-30	30	29.5	30
30-88	100	40	3
88-216	150	43.5	3
216-960	200	46	3
Above 960	500	54	3

The provisions of §15.205 apply to intentional radiators operating under this section, 15.205 Restricted bands of operation

MHz	MHz	MHz	GHz
0.090-0.110	16.42-16.423	399.9-410	4.5-5.15
10.495-0.505	16.69475-16.69525	608-614	5.35-5.46
2.1735-2.1905	16.80425-16.80475	960-1240	7.25-7.75
4.125-4.128	25.5-25.67	1300-1427	8.025-8.5
4.17725-4.17775	37.5-38.25	1435-1626.5	9.0-9.2
4.20725-4.20775	73-74.6	1645.5-1646.5	9.3-9.5
6.215-6.218	74.8-75.2	1660-1710	10.6-12.7
6.26775-6.26825	123-138	2200-2300	14.47-14.5
8.291-8.294	149.9-150.05	2310-2390	15.35-16.2
8.362-8.366	156.52475-156.52525	2483.5-2500	17.7-21.4
8.37625-8.38675	156.7-156.9	2690-2900	22.01-23.12
8.41425-8.41475	162.0125-167.17	3260-3267	23.6-24.0
12.29-12.293	167.72-173.2	3332-3339	31.2-31.8
12.51975-12.52025	240-285	3345.8-3358	36.43-36.5
12.57675-12.57725	322-335.4	3600-4400	(2)
13.36-13.41			

- Remark:
1. Emission level in $\text{dBuV/m} = 20 \log (\mu\text{V/m})$
 2. Measurement was performed at an antenna to the closed point of EUT distance of meters.
 3. Only spurious frequency is permitted to locate within the Restricted Bands specified in provision of ξ 15.205, and the emissions located in restricted bands also comply with 15.209 limit.

8.4.3 Test Configuration

Test according to clause 6.2 radio frequency test setup 2.

8.4.4 Test Procedure

■ Unwanted Emissions Measurements below 1000 MHz

Compliance shall be demonstrated using CISPR quasi-peak detection; however, peak detection is permitted as an alternative to quasi-peak detection.

The EUT was placed on a turn table which is 0.8m above ground plane.

And also, each emission was to be maximized by changing the polarization of receiving antenna both horizontal and vertical.

Repeat above procedures until all frequency measured was complete.

We use software control the EUT, Let EUT hopping on and transmit with highest power, All the modes have been tested and the worst result was reported.

Use the following spectrum analyzer settings:

Set RBW=120kHz for $f < 1 \text{ GHz}$ (30MHz to 1GHz), 200Hz for $f < 150\text{kHz}$ (9kHz to 150kHz), 9kHz for $< 30\text{MHz}$ (150kHz to 30kHz).

Set the VBW > RBW.

Detector = Peak.

Trace mode = max hold.

Follow the guidelines in ANSI C63.10-2013 with respect to maximizing the emission by rotating the EUT, measuring the emission while the EUT is situated in three orthogonal planes (if appropriate), adjusting the measurement antenna height and polarization, etc. A pre-amp and a high pass filter are required for this test, in order to provide the measuring system with sufficient sensitivity. Allow the trace to stabilize. The peak reading of the emission, after being corrected by the antenna factor, cable loss, pre-amp gain, etc., is the peak field strength, which must comply with the limit specified in Section 15.35(b). Submit this data.

Repeat above procedures until all frequency measured was complete.

■ Unwanted Maximum peak Emissions Measurements above 1000 MHz

Maximum emission levels are measured by setting the analyzer as follows:

RBW = 1 MHz.

VBW \geq 3 MHz.

Detector = Peak.

Sweep time = auto.

Trace mode = max hold.

Allow sweeps to continue until the trace stabilizes. Note that if the transmission is not continuous, the time required for the trace to stabilize will increase by a factor of approximately $1/x$, where x is the duty cycle. For example, at 50 percent duty cycle, the measurement time will increase by a factor of two relative to measurement time for continuous transmission.

■ Unwanted Average Emissions Measurements above 1000 MHz

Method VB (Averaging using reduced video bandwidth): Alternative method.

RBW = 1 MHz.

Video bandwidth. • If the EUT is configured to transmit with duty cycle \geq 98 percent, set $\text{VBW} \leq \text{RBW}/100$ (i.e., 10 kHz) but not less than 10 Hz.

• If the EUT duty cycle is $<$ 98 percent, set $\text{VBW} \geq 1/T$, where T is defined in section II.B.1.a).

Video bandwidth mode or display mode • The instrument shall be set to ensure that video filtering is applied in the power domain. Typically, this requires setting the detector mode to RMS and setting the Average-VBW Type to Power (RMS).

• As an alternative, the analyzer may be set to linear detector mode. Ensure that video filtering is applied in linear voltage domain (rather than in a log or dB domain). Some analyzers require linear display mode in order to accomplish this. Others have a setting for Average-VBW Type, which can be set to "Voltage" regardless of the display mode.

Detector = Peak.

Sweep time = auto.

Trace mode = max hold.

Allow max hold to run for at least 50 traces if the transmitted signal is continuous or has at least 98 percent duty cycle. For lower duty cycles, increase the minimum number of traces by a factor of $1/x$, where x is the duty cycle. For example, use at least 200 traces if the duty cycle is 25 percent. (If a specific emission is demonstrated to be continuous—i.e., 100 percent duty cycle—rather than turning on and off with the transmit cycle, at least 50 traces shall be averaged).

■ **Band edge measurements.**

Unwanted band-edge emissions may be measured using either of the special band-edge measurement techniques (the marker-delta or integration methods) described below. Note that the marker-delta method is primarily a radiated measurement technique that requires the 99% occupied bandwidth edge to be within 2 MHz of the authorized band edge, whereas the integration method can be used in either a radiated or conducted measurement without any special requirement with regards to the displacement of the unwanted emission(s) relative to the authorized bandwidth.

Marker-Delta Method.

The marker-delta method, as described in ANSI C63.10, can be used to perform measurements of the radiated unwanted emissions level of emissions provided that the 99% occupied bandwidth of the fundamental is within 2 MHz of the authorized band-edge.

8.4.5 Test Results

Temperature :	25°C	ATM Pressure::	1011 mbar
Humidity :	60 %	Test Engineer:	CZF

- For Undesirable radiated Spurious Emission in U-NII – 1
 - Undesirable radiated Spurious Emission Above 1GHz (1GHz to 40GHz)
- All of the configurations or modes are tested, the data of the worst case is recorded in the report.
Highest gain of each antenna and highest output power is ANT2 and MIMO as below:

ANT2:

Test mode: 802.11n(20) Frequency(MHz): 5180

Freq. (MHz)	Ant.Pol. H/V	Field Strength (dBuV/m)	E.I.R.P (dBm)	Limit (dBm)	Over(dB)
7010.35	V	54.66	-40.57	-27	13.57
9909.52	V	61.18	-34.05	-27	7.05
12597.6	V	64.75	-30.48	-27	3.48
7990.41	H	56.66	-38.57	-27	11.57
10045.5	H	61.26	-33.97	-27	6.97
12568.6	H	64.48	-30.75	-27	3.75

Test mode: 802.11n(20) Frequency(MHz): 5200

Freq. (MHz)	Ant.Pol. H/V	Field Strength (dBuV/m)	E.I.R.P (dBm)	Limit (dBm)	Over(dB)
6952.35	V	55.60	-39.63	-27	12.63
9985.52	V	60.92	-34.31	-27	7.31
12584.6	V	65.19	-30.04	-27	3.04
7246.36	H	55.83	-39.4	-27	12.4
10112.5	H	61.07	-34.16	-27	7.16
12570.6	H	64.73	-30.5	-27	3.5

Test mode: 802.11n(20) Frequency(MHz): 5240

Freq. (MHz)	Ant.Pol. H/V	Field Strength (dBuV/m)	E.I.R.P (dBm)	Limit (dBm)	Over(dB)
8011.41	V	56.69	-38.54	-27	11.54
10665.5	V	62.35	-32.88	-27	5.88
12588.6	V	64.41	-30.82	-27	3.82
8662.45	H	57.74	-37.49	-27	10.49
10083.5	H	60.94	-34.29	-27	7.29
12563.6	H	63.89	-31.34	-27	4.34

Note: (1) All Readings are Peak Value (VBW=3MHz) and AV Value (VBW=10Hz).
 (2) Emission Level= Reading Level+Probe Factor +Cable Loss.
 (3)EIRP[dBm] = E[dBμV/m] + 20 log(d[meters]) - 104.77
 d is the measurement distance in 3 meters

ANT2:

Test mode:		802.11n(20)		Frequency(MHz): 5180	
Freq. (MHz)	Ant.Pol.	Emission Level(dBuV/m)	Limit 3m(dBuV/m)	Over(dB)	Detector
7010.35	V	54.66	74.00	19.34	Peak
9909.52	V	61.18	74.00	12.82	Peak
12597.6	V	64.75	74.00	9.25	Peak
7010.35	V	39.44	54.00	14.56	Avg
9909.52	V	41.86	54.00	12.14	Avg
12597.6	V	45.85	54.00	8.15	Avg
7990.41	H	56.66	74.00	17.34	Peak
10045.5	H	61.26	74.00	12.74	Peak
12568.6	H	64.48	74.00	9.52	Peak
7990.41	H	40.04	54.00	13.96	Avg
10045.5	H	41.83	54.00	12.17	Avg
12568.6	H	45.72	54.00	8.28	Avg

Test mode:		802.11n(20)		Frequency(MHz): 5200	
Freq. (MHz)	Ant.Pol.	Emission Level(dBuV/m)	Limit 3m(dBuV/m)	Over(dB)	Detector
6952.35	V	55.60	74.00	18.40	Peak
9985.52	V	60.92	74.00	13.08	Peak
12584.6	V	65.19	74.00	8.81	Peak
6952.35	V	39.75	54.00	14.25	Avg
9985.52	V	41.89	54.00	12.11	Avg
12584.6	V	45.66	54.00	8.34	Avg
7246.36	H	55.83	74.00	18.17	Peak
10112.5	H	61.07	74.00	12.93	Peak
12570.6	H	64.73	74.00	9.27	Peak
7246.36	H	39.30	54.00	14.70	Avg
10112.5	H	42.33	54.00	11.67	Avg
12570.6	H	45.97	54.00	8.03	Avg

Test mode:		802.11n(20)		Frequency(MHz): 5240	
Freq. (MHz)	Ant.Pol.	Emission Level(dBuV/m)	Limit 3m(dBuV/m)	Over(dB)	Detector
8011.41	V	56.69	74.00	17.31	Peak
10665.5	V	62.35	74.00	11.65	Peak
12588.6	V	64.41	74.00	9.59	Peak
8011.41	V	40.19	54.00	13.81	Avg
10665.5	V	44.59	54.00	9.41	Avg
12588.6	V	45.94	54.00	8.06	Avg
8662.45	H	57.74	74.00	16.26	Peak
10083.5	H	60.94	74.00	13.06	Peak
12563.6	H	63.89	74.00	10.11	Peak
8662.45	H	42.25	54.00	11.75	Avg
10083.5	H	42.77	54.00	11.23	Avg
12563.6	H	45.63	54.00	8.37	Avg

- Note:**
- (1) All Readings are Peak Value (VBW=3MHz) and Peak Value (VBW=10Hz).
 - (2) Emission Level= Reading Level+Correct Factor +Cable Loss.
 - (3) Correct Factor= Ant_F + Cab_L - Preamp
 - (4) The reading of emissions are attenuated more than 20dB below the permissible limits or the field strength is too small to be measured.

● Undesirable radiated Undesirable radiated Spurious Emission in Band Edge

Test mode: 802.11n(20) Frequency(MHz): 5180

Freq. (MHz)	Ant.Pol. H/V	Field Strength (RBW=100KHz) (dBuV/m)	E.I.R.P (dBm)	Limit (dBm)	Verdict
5149.59	V	54.23	-41	-27	Pass
5149.91	H	56.39	-38.84	-27	Pass

Test mode: 802.11n(20) Frequency(MHz): 5240

Freq. (MHz)	Ant.Pol. H/V	Field Strength (RBW=100KHz) (dBuV/m)	E.I.R.P (dBm)	Limit (dBm)	Verdict
5356.20	V	54.02	-41.21	-27	Pass
5351.18	H	54.24	-40.99	-27	Pass

- Note:** (1) All Readings are Peak Value (VBW=3MHz) and Peak Value (VBW=10Hz).
 (2) Emission Level= Reading Level+Correct Factor +Cable Loss.
 (3) Correct Factor= Ant_F + Cab_L - Preamp
 (4) EIRP[dBm] = E[dBuV/m] + 20 log(d[meters]) - 104.77
 d is the measurement distance in 3 meters

Test mode: 802.11n(20) Frequency(MHz): 5180

Freq. (MHz)	Ant.Pol.	Emission Level(dBuV/m)	Limit 3m(dBuV/m)	Over(dB)	Detector
5149.59	V	54.23	74.00	19.77	Peak
5149.59	V	45.01	54.00	8.99	Avg
5149.91	H	56.39	74.00	17.61	Peak
5149.91	H	44.76	54.00	9.24	Avg

Test mode: 802.11n(20) Frequency(MHz): 5240

Freq. (MHz)	Ant.Pol.	Emission Level(dBuV/m)	Limit 3m(dBuV/m)	Over(dB)	Detector
5356.20	V	54.02	74.00	19.98	Peak
5356.20	V	45.33	54.00	8.67	Avg
5351.18	H	54.24	74.00	19.76	Peak
5351.18	H	45.00	54.00	9.00	Avg

- Note:** (1) All Readings are Peak Value (VBW=3MHz) and Peak Value (VBW=10Hz).
 (2) Emission Level= Reading Level+Correct Factor +Cable Loss.
 (3) Correct Factor= Ant_F + Cab_L - Preamp
 (4) The reading of emissions are attenuated more than 20dB below the permissible limits or the field strength is too small to be measured.

U-NII - 1

Test Model Undesirable radiated Spurious Emission in Restricted Band (5100-5150MHz)

802.11a 802.11n(HT20) 802.11n(HT40)

5180 5200 5240 Ant.Pol V

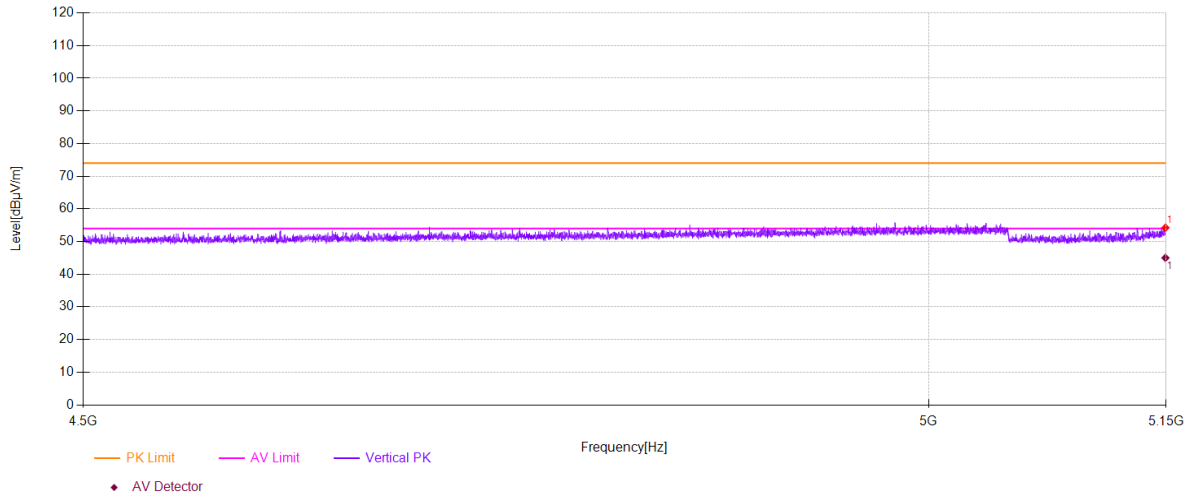

U-NII - 1

Test Model Undesirable radiated Spurious Emission in Restricted Band (5100-5150MHz)

802.11a 802.11n(HT20) 802.11n(HT40)

5180 5200 5240 Ant.Pol H

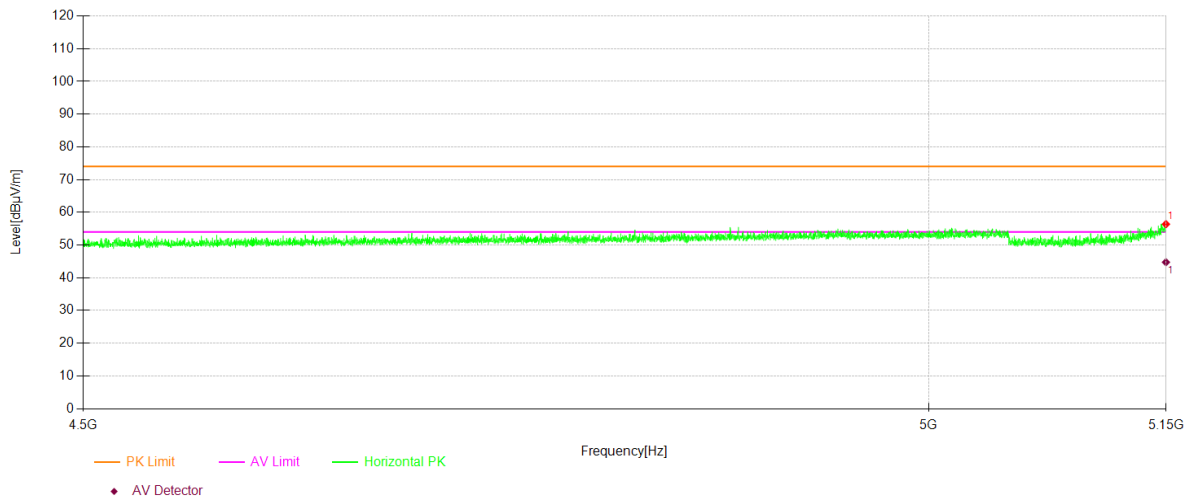

U-NII - 1

Test Model Undesirable radiated Spurious Emission in Restricted Band (5350-5400MHz)

<input type="checkbox"/> 802.11a	<input checked="" type="checkbox"/> 802.11n(HT20)	<input type="checkbox"/> 802.11n(HT40)
<input type="checkbox"/> 5180	<input type="checkbox"/> 5200	<input checked="" type="checkbox"/> 5240
		Ant. Pol V

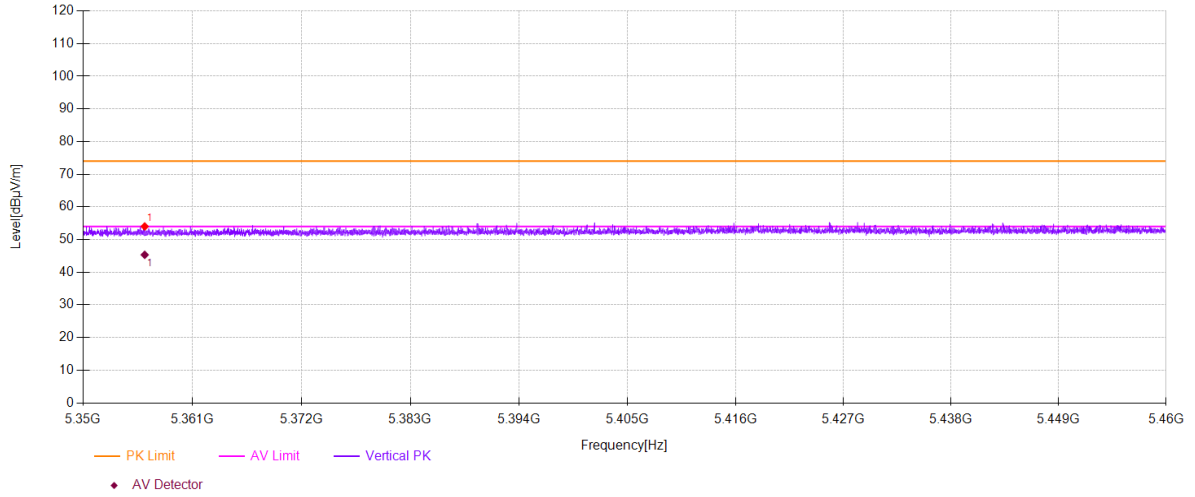

U-NII - 1

Test Model Undesirable radiated Spurious Emission in Restricted Band (5350-5400MHz)

<input type="checkbox"/> 802.11a	<input checked="" type="checkbox"/> 802.11n(HT20)	<input type="checkbox"/> 802.11n(HT40)
<input type="checkbox"/> 5180	<input type="checkbox"/> 5200	<input checked="" type="checkbox"/> 5240
		Ant. Pol H

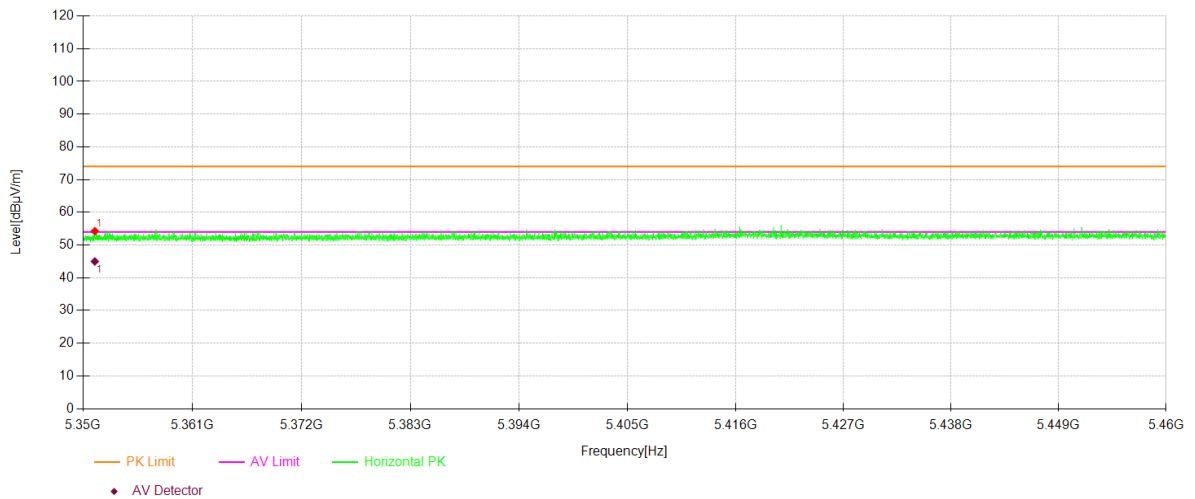

- For Undesirable radiated Spurious Emission in U-NII -2A
 - Undesirable radiated Spurious Emission Above 1GHz (1GHz to 40GHz)
- All of the configurations or modes are tested, the data of the worst case is recorded in the report.
Highest gain of each antenna and highest output power is ANT2 and MIMO as below:

ANT2:

Test mode: 802.11n(20) Frequency(MHz): 5260

Freq. (MHz)	Ant.Pol. H/V	Field Strength (dBuV/m)	E.I.R.P (dBm)	Limit (dBm)	Over(dB)
7989.41	V	57.65	-37.58	-27	10.58
10002.5	V	61.41	-33.82	-27	6.82
14222.7	V	64.71	-30.52	-27	3.52
8678.45	H	58.14	-37.09	-27	10.09
10684.5	H	62.10	-33.13	-27	6.13
12620.6	H	65.24	-29.99	-27	2.99

Test mode: 802.11n(20) Frequency(MHz): 5280

Freq. (MHz)	Ant.Pol. H/V	Field Strength (dBuV/m)	E.I.R.P (dBm)	Limit (dBm)	Over(dB)
8027.41	V	56.81	-38.42	-27	11.42
9996.52	V	61.49	-33.74	-27	6.74
12577.6	V	64.14	-31.09	-27	4.09
8670.45	H	58.04	-37.19	-27	10.19
10677.5	H	62.54	-32.69	-27	5.69
12607.6	H	64.29	-30.94	-27	3.94

Test mode: 802.11n(20) Frequency(MHz): 5320

Freq. (MHz)	Ant.Pol. H/V	Field Strength (dBuV/m)	E.I.R.P (dBm)	Limit (dBm)	Over(dB)
8677.45	V	57.89	-37.34	-27	10.34
10728.5	V	62.19	-33.04	-27	6.04
12666.6	V	64.36	-30.87	-27	3.87
7985.41	H	56.16	-39.07	-27	12.07
10073.5	H	61.51	-33.72	-27	6.72
12579.6	H	65.08	-30.15	-27	3.15

Note: (1) All Readings are Peak Value (VBW=3MHz) and AV Value (VBW=10Hz).
 (2) Emission Level= Reading Level+Probe Factor +Cable Loss.
 (3)EIRP[dBm] = E[dBμV/m] + 20 log(d[meters]) - 104.77
 d is the measurement distance in 3 meters

ANT2:

Test mode:		802.11n(20)		Frequency(MHz): 5260	
Freq. (MHz)	Ant.Pol.	Emission Level(dBuV/m)	Limit 3m(dBuV/m)	Over(dB)	Detector
7989.41	V	57.65	74.00	16.35	Peak
10002.5	V	61.41	74.00	12.59	Peak
14222.7	V	64.71	74.00	9.29	Peak
7989.41	V	39.85	54.00	14.15	Avg
10002.5	V	41.97	54.00	12.03	Avg
14222.7	V	46.72	54.00	7.28	Avg
8678.45	H	58.14	74.00	15.86	Peak
10684.5	H	62.10	74.00	11.90	Peak
12620.6	H	65.24	74.00	8.76	Peak
8678.45	H	42.77	54.00	11.23	Avg
10684.5	H	45.17	54.00	8.83	Avg
12620.6	H	46.19	54.00	7.81	Avg

Test mode:		802.11n(20)		Frequency(MHz): 5280	
Freq. (MHz)	Ant.Pol.	Emission Level(dBuV/m)	Limit 3m(dBuV/m)	Over(dB)	Detector
8027.41	V	56.81	74.00	17.19	Peak
9996.52	V	61.49	74.00	12.51	Peak
12577.6	V	64.14	74.00	9.86	Peak
8027.41	V	40.10	54.00	13.90	Avg
9996.52	V	41.91	54.00	12.09	Avg
12577.6	V	45.50	54.00	8.50	Avg
8670.45	H	58.04	74.00	15.96	Peak
10677.5	H	62.54	74.00	11.46	Peak
12607.6	H	64.29	74.00	9.71	Peak
8670.45	H	42.20	54.00	11.80	Avg
10677.5	H	44.96	54.00	9.04	Avg
12607.6	H	46.46	54.00	7.54	Avg

Test mode:		802.11n(20)		Frequency(MHz): 5320	
Freq. (MHz)	Ant.Pol.	Emission Level(dBuV/m)	Limit 3m(dBuV/m)	Over(dB)	Detector
8677.45	V	57.89	74.00	16.11	Peak
10728.5	V	62.19	74.00	11.81	Peak
12666.6	V	64.36	74.00	9.64	Peak
8677.45	V	42.31	54.00	11.69	Avg
10728.5	V	45.18	54.00	8.82	Avg
12666.6	V	45.81	54.00	8.19	Avg
7985.41	H	56.16	74.00	17.84	Peak
10073.5	H	61.51	74.00	12.49	Peak
12579.6	H	65.08	74.00	8.92	Peak
7985.41	H	39.86	54.00	14.14	Avg
10073.5	H	42.67	54.00	11.33	Avg
12579.6	H	46.32	54.00	7.68	Avg

- Note:**
- (1) All Readings are Peak Value (VBW=3MHz) and Peak Value (VBW=10Hz).
 - (2) Emission Level= Reading Level+Correct Factor +Cable Loss.
 - (3) Correct Factor= Ant_F + Cab_L - Preamp
 - (4) The reading of emissions are attenuated more than 20dB below the permissible limits or the field strength is too small to be measured.

- ☒ Undesirable radiated Undesirable radiated Spurious Emission in Band Edge

Test mode: 802.11n(20) Frequency(MHz): 5260

Freq. (MHz)	Ant.Pol. H/V	Field Strength (RBW=100KHz) (dBuV/m)	E.I.R.P (dBm)	Limit (dBm)	Verdict
5142.76	V	53.24	-41.99	-27	Pass
5143.66	H	53.47	-41.76	-27	Pass

Test mode: 802.11n(20) Frequency(MHz): 5320

Freq. (MHz)	Ant.Pol. H/V	Field Strength (RBW=100KHz) (dBuV/m)	E.I.R.P (dBm)	Limit (dBm)	Verdict
5350.71	V	55.44	-39.79	-27	Pass
5353.76	H	57.69	-37.54	-27	Pass

- Note:** (1) All Readings are Peak Value (VBW=3MHz) and Peak Value (VBW=10Hz).
 (2) Emission Level= Reading Level+Correct Factor +Cable Loss.
 (3) Correct Factor= Ant_F + Cab_L - Preamp
 (4) EIRP[dBm] = E[dBuV/m] + 20 log(d[meters]) - 104.77
 d is the measurement distance in 3 meters

Test mode: 802.11n(20) Frequency(MHz): 5260

Freq. (MHz)	Ant.Pol.	Emission Level(dBuV/m)	Limit 3m(dBuV/m)	Over(dB)	Detector
5142.76	V	53.24	74.00	20.76	Peak
5142.76	V	44.99	54.00	9.01	Avg
5143.66	H	53.47	74.00	20.53	Peak
5143.66	H	44.45	54.00	9.55	Avg

Test mode: 802.11n(20) Frequency(MHz): 5320

Freq. (MHz)	Ant.Pol.	Emission Level(dBuV/m)	Limit 3m(dBuV/m)	Over(dB)	Detector
5350.71	V	55.44	74.00	18.56	Peak
5350.71	V	45.24	54.00	8.76	Avg
5353.76	H	57.69	74.00	16.31	Peak
5353.76	H	45.16	54.00	8.84	Avg

- Note:** (1) All Readings are Peak Value (VBW=3MHz) and Peak Value (VBW=10Hz).
 (2) Emission Level= Reading Level+Correct Factor +Cable Loss.
 (3) Correct Factor= Ant_F + Cab_L - Preamp
 (4)The reading of emissions are attenuated more than 20dB below the permissible limits or the field strength is too small to be measured.

Test Model		U-NII -2A				
		Undesirable radiated Spurious Emission in Restricted Band (5100-5150MHz)				
	<input type="checkbox"/> 802.11a	<input checked="" type="checkbox"/> 802.11n(HT20)	<input type="checkbox"/> 802.11 ac (VHT20)			
	<input checked="" type="checkbox"/> 5260	<input type="checkbox"/> 5300	<input type="checkbox"/> 5320	Ant.Pol	V	

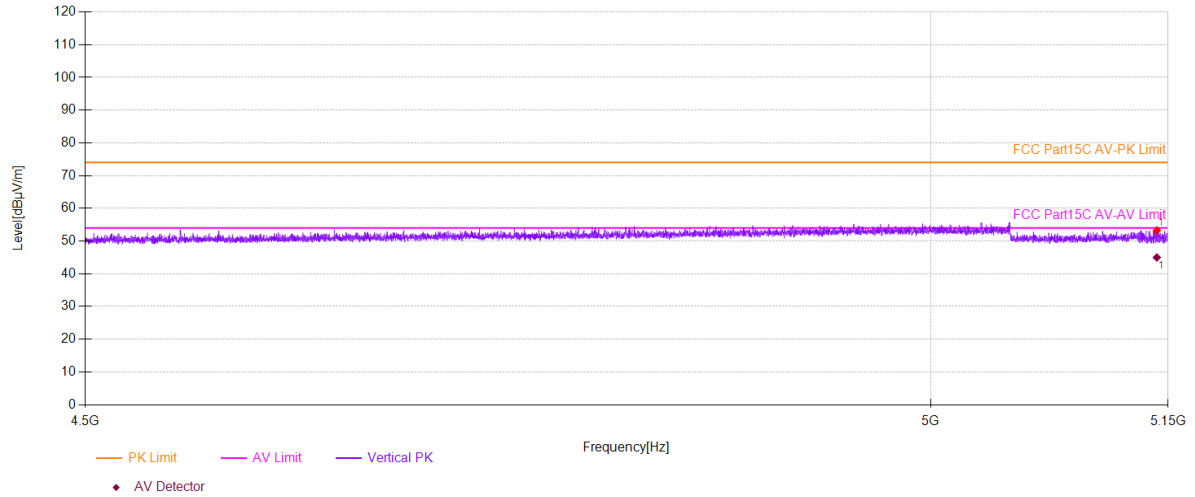

Test Model		U-NII -2A				
		Undesirable radiated Spurious Emission in Restricted Band (5100-5150MHz)				
	<input type="checkbox"/> 802.11a	<input checked="" type="checkbox"/> 802.11n(HT20)	<input type="checkbox"/> 802.11 ac (VHT20)			
	<input checked="" type="checkbox"/> 5260	<input type="checkbox"/> 5300	<input type="checkbox"/> 5320	Ant.Pol	H	

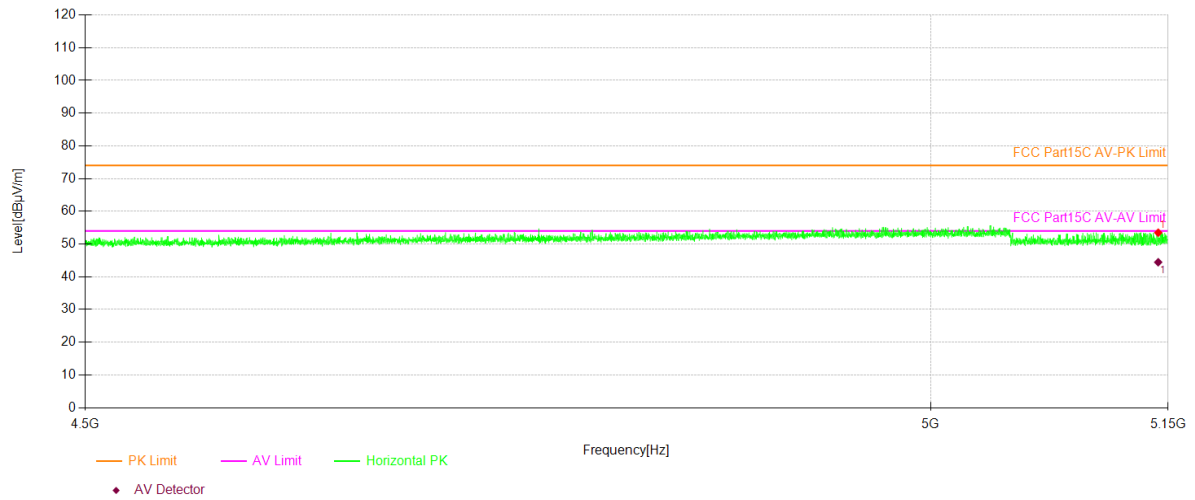

U-NII -2A				
Test Model	Undesirable radiated Spurious Emission in Restricted Band (5350-5400MHz)			
	<input type="checkbox"/> 802.11a	<input checked="" type="checkbox"/> 802.11n(HT20)	<input type="checkbox"/> 802.11 ac (VHT20)	
	<input type="checkbox"/> 5260	<input type="checkbox"/> 5300	<input checked="" type="checkbox"/> 5320	Ant.Pol V

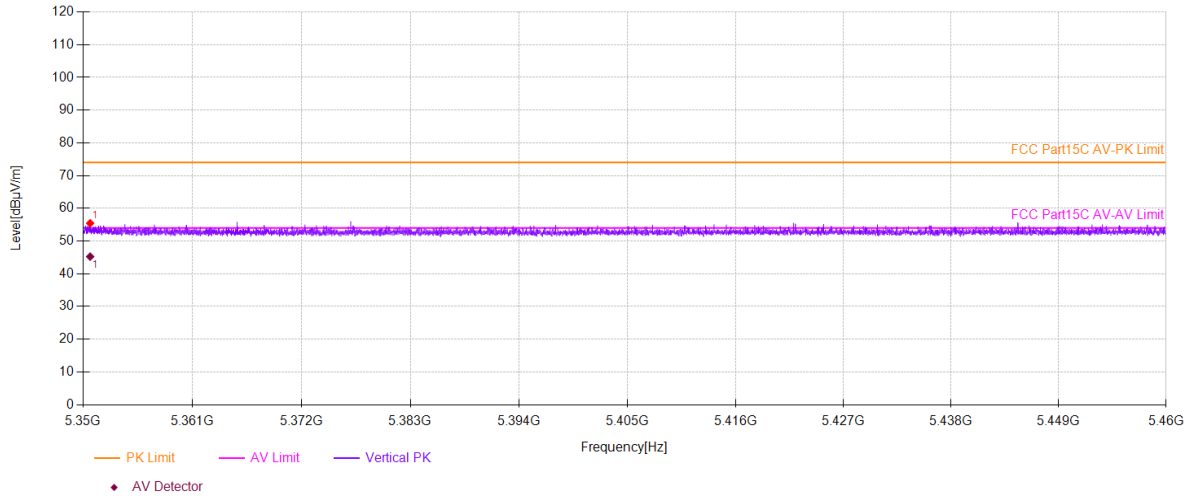

U-NII -2A				
Test Model	Undesirable radiated Spurious Emission in Restricted Band (5350-5400MHz)			
	<input type="checkbox"/> 802.11a	<input checked="" type="checkbox"/> 802.11n(HT20)	<input type="checkbox"/> 802.11 ac (VHT20)	
	<input type="checkbox"/> 5260	<input type="checkbox"/> 5300	<input checked="" type="checkbox"/> 5320	Ant.Pol H

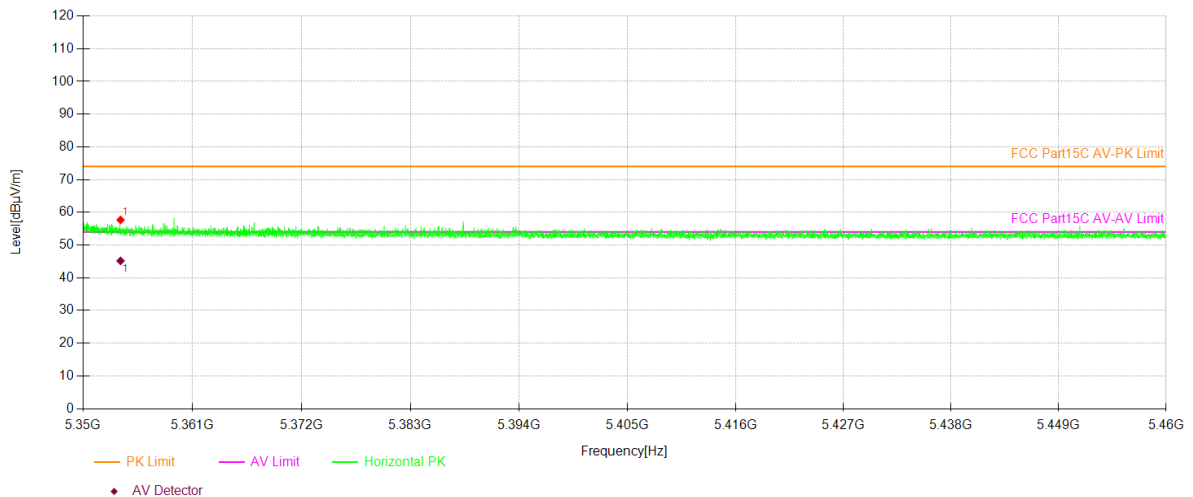

- For Undesirable radiated Spurious Emission in U-NII -2C
 - Undesirable radiated Spurious Emission Above 1GHz (1GHz to 40GHz)
- All of the configurations or modes are tested, the data of the worst case is recorded in the report.
Highest gain of each antenna and highest output power is ANT2 and MIMO as below:

ANT2:

Test mode: 802.11n(20) Frequency(MHz): 5500

Freq. (MHz)	Ant.Pol. H/V	Field Strength (dBuV/m)	E.I.R.P (dBm)	Limit (dBm)	Over(dB)
7987.41	V	57.70	-37.53	-27	10.53
10044.5	V	62.38	-32.85	-27	5.85
14347.7	V	66.04	-29.19	-27	2.19
8710.45	H	58.33	-36.9	-27	9.9
11116.5	H	62.79	-32.44	-27	5.44
14283.7	H	65.82	-29.41	-27	2.41

Test mode: 802.11n(20) Frequency(MHz): 5580

Freq. (MHz)	Ant.Pol. H/V	Field Strength (dBuV/m)	E.I.R.P (dBm)	Limit (dBm)	Over(dB)
8692.45	V	58.24	-36.99	-27	9.99
10659.5	V	63.23	-32	-27	5
14326.7	V	67.55	-27.68	-27	0.68
8179.42	H	58.33	-36.9	-27	9.9
10112.5	H	61.61	-33.62	-27	6.62
14328.7	H	65.92	-29.31	-27	2.31

Test mode: 802.11n(20) Frequency(MHz): 5700

Freq. (MHz)	Ant.Pol. H/V	Field Strength (dBuV/m)	E.I.R.P (dBm)	Limit (dBm)	Over(dB)
8694.45	V	58.74	-36.49	-27	9.49
10679.5	V	63.16	-32.07	-27	5.07
14326.7	V	66.72	-28.51	-27	1.51
8104.41	H	56.97	-38.26	-27	11.26
10685.5	H	62.03	-33.2	-27	6.2
14222.7	H	66.48	-28.75	-27	1.75

- Note:** (1) All Readings are Peak Value (VBW=3MHz) and AV Value (VBW=10Hz).
 (2) Emission Level= Reading Level+Probe Factor +Cable Loss.
 (3) EIRP[dBm] = E[dBμV/m] + 20 log(d[meters]) - 104.77
 d is the measurement distance in 3 meters

ANT2:

Test mode:		802.11n(20)		Frequency(MHz): 5500	
Freq. (MHz)	Ant.Pol.	Emission Level(dBuV/m)	Limit 3m(dBuV/m)	Over(dB)	Detector
7987.41	V	57.70	74.00	16.30	Peak
10044.5	V	62.38	74.00	11.62	Peak
14347.7	V	66.04	74.00	7.96	Peak
7987.41	V	40.06	54.00	13.94	Avg
10044.5	V	42.43	54.00	11.57	Avg
14347.7	V	47.45	54.00	6.55	Avg
8710.45	H	58.33	74.00	15.67	Peak
11116.5	H	62.79	74.00	11.21	Peak
14283.7	H	65.82	74.00	8.18	Peak
8710.45	H	43.02	54.00	10.98	Avg
11116.5	H	44.17	54.00	9.83	Avg
14283.7	H	46.25	54.00	7.75	Avg

Test mode:		802.11n(20)		Frequency(MHz): 5580	
Freq. (MHz)	Ant.Pol.	Emission Level(dBuV/m)	Limit 3m(dBuV/m)	Over(dB)	Detector
8692.45	V	58.24	74.00	15.76	Peak
10659.5	V	63.23	74.00	10.77	Peak
14326.7	V	67.55	74.00	6.45	Peak
8692.45	V	43.01	54.00	10.99	Avg
10659.5	V	44.13	54.00	9.87	Avg
14326.7	V	46.04	54.00	7.96	Avg
8179.42	H	58.33	74.00	15.67	Peak
10112.5	H	61.61	74.00	12.39	Peak
14328.7	H	65.92	74.00	8.08	Peak
8179.42	H	40.53	54.00	13.47	Avg
10112.5	H	42.57	54.00	11.43	Avg
14328.7	H	47.28	54.00	6.72	Avg

Test mode:		802.11n(20)		Frequency(MHz): 5700	
Freq. (MHz)	Ant.Pol.	Emission Level(dBuV/m)	Limit 3m(dBuV/m)	Over(dB)	Detector
8694.45	V	58.74	74.00	15.26	Peak
10679.5	V	63.16	74.00	10.84	Peak
14326.7	V	66.72	74.00	7.28	Peak
8694.45	V	42.94	54.00	11.06	Avg
10679.5	V	45.05	54.00	8.95	Avg
14326.7	V	46.13	54.00	7.87	Avg
8104.41	H	56.97	74.00	17.03	Peak
10685.5	H	62.03	74.00	11.97	Peak
14222.7	H	66.48	74.00	7.52	Peak
8104.41	H	40.77	54.00	13.23	Avg
10685.5	H	45.21	54.00	8.79	Avg
14222.7	H	46.23	54.00	7.77	Avg

- Note:**
- (1) All Readings are Peak Value (VBW=3MHz) and Peak Value (VBW=10Hz).
 - (2) Emission Level= Reading Level+Correct Factor +Cable Loss.
 - (3) Correct Factor= Ant_F + Cab_L - Preamp
 - (4) The reading of emissions are attenuated more than 20dB below the permissible limits or the field strength is too small to be measured.

● Undesirable radiated Undesirable radiated Spurious Emission in Band Edge

Test mode: 802.11n(20) Frequency(MHz): 5500

Freq. (MHz)	Ant.Pol. H/V	Field Strength (RBW=100KHz) (dBuV/m)	E.I.R.P (dBm)	Limit (dBm)	Verdict
5469.43	V	58.32	-36.91	-27	Pass
5468.98	H	59.66	-35.57	-27	Pass

Test mode: 802.11n(20) Frequency(MHz): 5700

Freq. (MHz)	Ant.Pol. H/V	Field Strength (RBW=100KHz) (dBuV/m)	E.I.R.P (dBm)	Limit (dBm)	Verdict
5725.15	V	65.78	-29.45	-27	Pass
5726.04	H	64.44	-30.79	-27	Pass

Note: (1) All Readings are Peak Value (VBW=3MHz) and Peak Value (VBW=10Hz).
 (2) Emission Level= Reading Level+Correct Factor +Cable Loss.
 (3) Correct Factor= Ant_F + Cab_L - Preamp
 (4) EIRP[dBm] = E[dBuV/m] + 20 log(d[meters]) - 104.77
 d is the measurement distance in 3 meters

Test mode: 802.11n(20) Frequency(MHz): 5500

Freq. (MHz)	Ant.Pol.	Emission Level(dBuV/m)	Limit 3m(dBuV/m)	Over(dB)	Detector
5469.43	V	58.32	74.00	15.68	Peak
5469.43	V	45.82	54.00	8.18	Avg
5468.98	H	59.66	74.00	14.34	Peak
5468.98	H	46.11	54.00	7.89	Avg

Test mode: 802.11n(20) Frequency(MHz): 5700

Freq. (MHz)	Ant.Pol.	Emission Level(dBuV/m)	Limit 3m(dBuV/m)	Over(dB)	Detector
5725.15	V	65.78	74.00	8.22	Peak
5725.15	V	50.83	54.00	3.17	Avg
5726.04	H	64.44	74.00	9.56	Peak
5726.04	H	50.01	54.00	3.99	Avg

Note: (1) All Readings are Peak Value (VBW=3MHz) and Peak Value (VBW=10Hz).
 (2) Emission Level= Reading Level+Correct Factor +Cable Loss.
 (3) Correct Factor= Ant_F + Cab_L - Preamp
 (4) The reading of emissions are attenuated more than 20dB below the permissible limits or the field strength is too small to be measured.

U-NII -2C

Test Model Undesirable radiated Spurious Emission in Restricted Band (5100-5150MHz)

<input type="checkbox"/> 802.11a	<input checked="" type="checkbox"/> 802.11n(HT20)	<input type="checkbox"/> 802.11 ac (VHT20)
<input checked="" type="checkbox"/> 5500	<input type="checkbox"/> 5580	<input type="checkbox"/> 5700
Ant.Pol		V

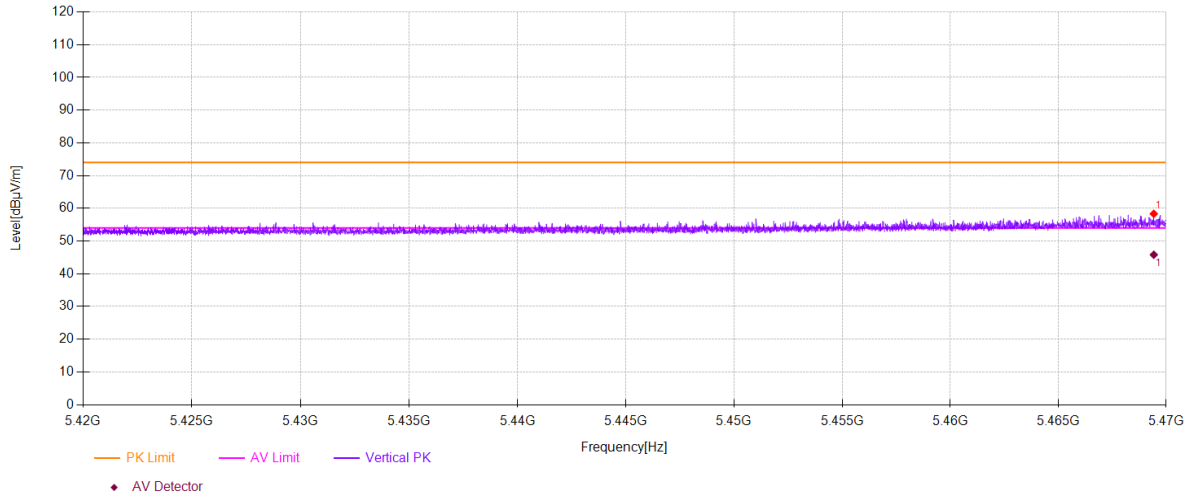

U-NII -2C

Test Model Undesirable radiated Spurious Emission in Restricted Band (5100-5150MHz)

<input type="checkbox"/> 802.11a	<input checked="" type="checkbox"/> 802.11n(HT20)	<input type="checkbox"/> 802.11 ac (VHT20)
<input checked="" type="checkbox"/> 5500	<input type="checkbox"/> 5580	<input type="checkbox"/> 5700
Ant.Pol		H

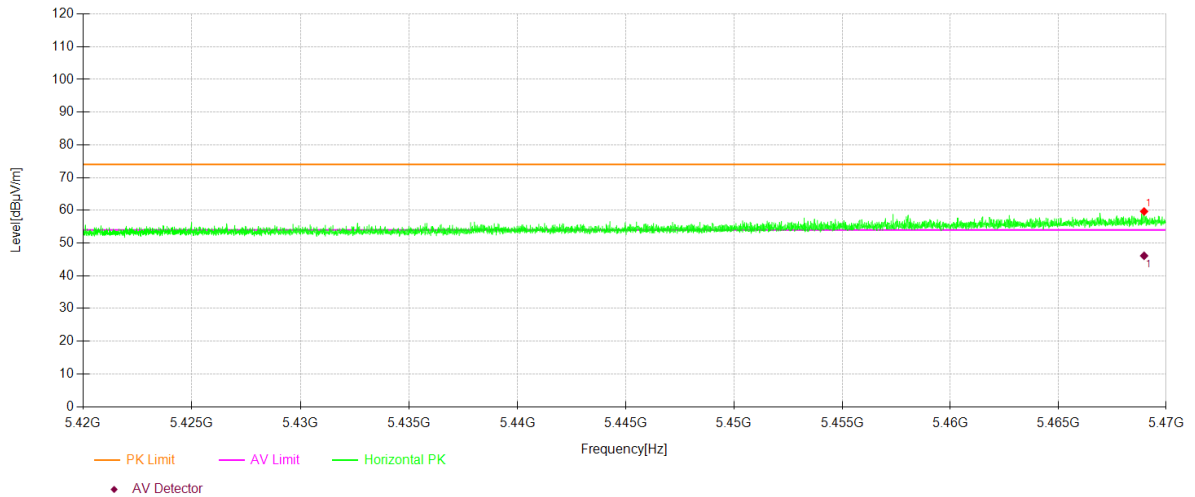

U-NII -2C

Test Model Undesirable radiated Spurious Emission in Restricted Band (5350-5400MHz)

<input type="checkbox"/> 802.11a	<input checked="" type="checkbox"/> 802.11n(HT20)	<input type="checkbox"/> 802.11 ac (VHT20)	
<input type="checkbox"/> 5500	<input type="checkbox"/> 5580	<input checked="" type="checkbox"/> 5700	Ant.Pol V

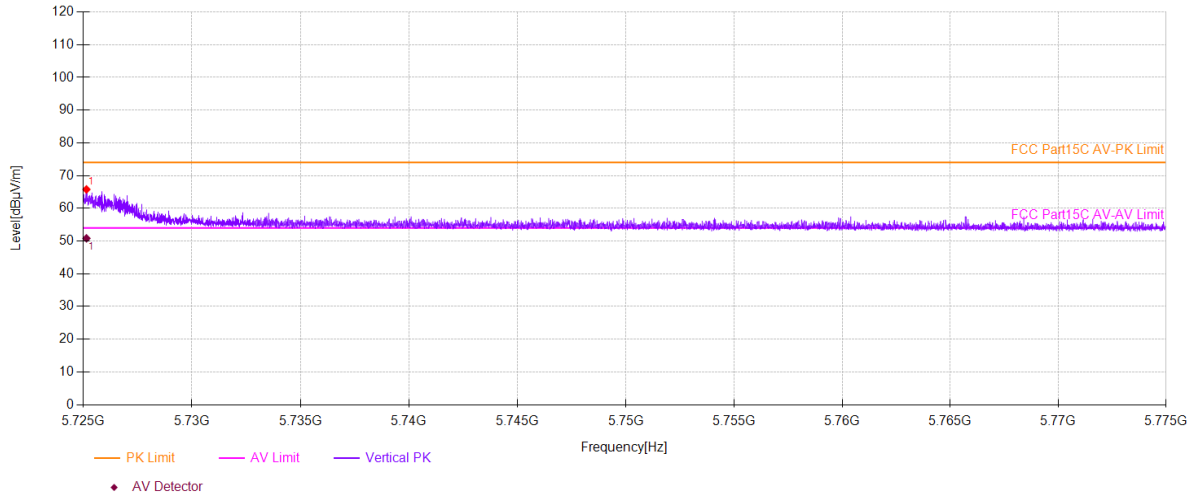

U-NII -2C

Test Model Undesirable radiated Spurious Emission in Restricted Band (5350-5400MHz)

<input type="checkbox"/> 802.11a	<input checked="" type="checkbox"/> 802.11n(HT20)	<input type="checkbox"/> 802.11 ac (VHT20)	
<input type="checkbox"/> 5500	<input type="checkbox"/> 5580	<input checked="" type="checkbox"/> 5700	Ant.Pol H

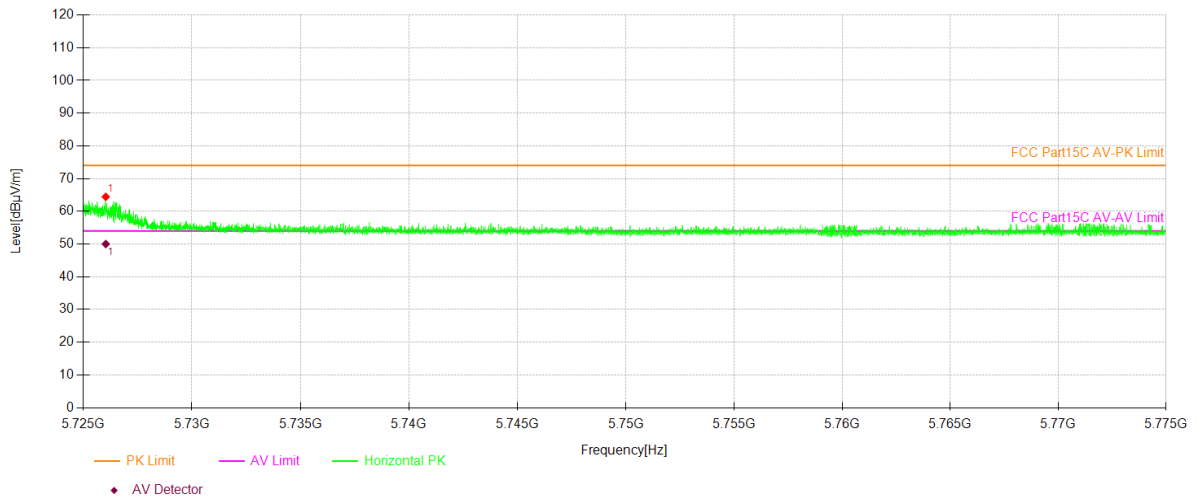

- For Undesirable radiated Spurious Emission in U-NII -3
 - Undesirable radiated Spurious Emission Above 1GHz (1GHz to 40GHz)
- All of the configurations or modes are tested, the data of the worst case is recorded in the report.
Highest gain of each antenna and highest output power is ANT2 and MIMO as below:

ANT2:

Test mode: 802.11n(20) Frequency(MHz): 5745

Freq. (MHz)	Ant.Pol. H/V	Field Strength (dBuV/m)	E.I.R.P (dBm)	Limit (dBm)	Over(dB)
8076.41	V	57.42	-37.81	-27	10.81
10737.5	V	63.05	-32.18	-27	5.18
14312.7	V	66.80	-28.43	-27	1.43
8103.4	H	57.80	-37.43	-27	10.43
11117.5	H	62.77	-32.46	-27	5.46
14334.7	H	65.92	-29.31	-27	2.31

Test mode: 802.11n(20) Frequency(MHz): 5785

Freq. (MHz)	Ant.Pol. H/V	Field Strength (dBuV/m)	E.I.R.P (dBm)	Limit (dBm)	Over(dB)
8664.45	V	58.50	-36.73	-27	9.73
11088.5	V	63.05	-32.18	-27	5.18
14309.7	V	66.23	-29	-27	2
8699.45	H	58.40	-36.83	-27	9.83
11043.5	H	62.46	-32.77	-27	5.77
14182.7	H	66.28	-28.95	-27	1.95

Test mode: 802.11n(20) Frequency(MHz): 5825

Freq. (MHz)	Ant.Pol. H/V	Field Strength (dBuV/m)	E.I.R.P (dBm)	Limit (dBm)	Over(dB)
9343.49	V	59.14	-36.09	-27	9.09
10682.5	V	62.45	-32.78	-27	5.78
14182.7	V	66.63	-28.6	-27	1.6
8720.45	H	59.61	-35.62	-27	8.62
10685.5	H	64.57	-30.66	-27	3.66
14261.7	H	66.23	-29	-27	2

- Note:** (1) All Readings are Peak Value (VBW=3MHz) and AV Value (VBW=10Hz).
 (2) Emission Level= Reading Level+Probe Factor +Cable Loss.
 (3) EIRP[dBm] = E[dBuV/m] + 20 log(d[meters]) - 104.77
 d is the measurement distance in 3 meters

ANT2:

Test mode:		802.11n(20)		Frequency(MHz): 5745	
Freq. (MHz)	Ant.Pol.	Emission Level(dBuV/m)	Limit 3m(dBuV/m)	Over(dB)	Detector
8076.41	V	57.42	74.00	16.58	Peak
10737.5	V	63.05	74.00	10.95	Peak
14312.7	V	66.80	74.00	7.20	Peak
8076.41	V	40.61	54.00	13.39	Avg
10737.5	V	45.01	54.00	8.99	Avg
14312.7	V	47.65	54.00	6.35	Avg
8103.41	H	57.80	74.00	16.20	Peak
11117.5	H	62.77	74.00	11.23	Peak
14334.7	H	65.92	74.00	8.08	Peak
8103.41	H	41.03	54.00	12.97	Avg
11117.5	H	44.23	54.00	9.77	Avg
14334.7	H	47.79	54.00	6.21	Avg

Test mode:		802.11n(20)		Frequency(MHz): 5785	
Freq. (MHz)	Ant.Pol.	Emission Level(dBuV/m)	Limit 3m(dBuV/m)	Over(dB)	Detector
8664.45	V	58.50	74.00	15.50	Peak
11088.5	V	63.05	74.00	10.95	Peak
14309.7	V	66.23	74.00	7.77	Peak
8664.45	V	42.49	54.00	11.51	Avg
11088.5	V	44.09	54.00	9.91	Avg
14309.7	V	46.40	54.00	7.60	Avg
8699.45	H	58.40	74.00	15.60	Peak
11043.5	H	62.46	74.00	11.54	Peak
14182.7	H	66.28	74.00	7.72	Peak
8699.45	H	42.77	54.00	11.23	Avg
11043.5	H	44.68	54.00	9.32	Avg
14182.7	H	45.00	54.00	9.00	Avg

Test mode:		802.11n(20)		Frequency(MHz): 5825	
Freq. (MHz)	Ant.Pol.	Emission Level(dBuV/m)	Limit 3m(dBuV/m)	Over(dB)	Detector
9343.49	V	59.14	74.00	14.86	Peak
10682.5	V	62.45	74.00	11.55	Peak
14182.7	V	66.63	74.00	7.37	Peak
9343.49	V	43.55	54.00	10.45	Avg
10682.5	V	45.13	54.00	8.87	Avg
14182.7	V	45.05	54.00	8.95	Avg
8720.45	H	59.61	74.00	14.39	Peak
10685.5	H	64.57	74.00	9.43	Peak
14261.7	H	66.23	74.00	7.77	Peak
8720.45	H	42.83	54.00	11.17	Avg
10685.5	H	45.51	54.00	8.49	Avg
14261.7	H	47.00	54.00	7.00	Avg

- Note:**
- (1) All Readings are Peak Value (VBW=3MHz) and Peak Value (VBW=10Hz).
 - (2) Emission Level= Reading Level+Correct Factor +Cable Loss.
 - (3) Correct Factor= Ant_F + Cab_L - Preamp
 - (4) The reading of emissions are attenuated more than 20dB below the permissible limits or the field strength is too small to be measured.

- Undesirable radiated Spurious Emission in band edge

Test mode: 802.11n(20) Frequency: 5745

Freq. (MHz)	Ant.Pol. H/V	Field Strength (RBW=100KHz) (dBuV/m)	E.I.R.P (dBm)	Limit (dBm)	Verdict
5724.56	V	73.20	-22.03	-27	PASS
5722.99	H	72.85	-22.38	-27	PASS

Test mode: 802.11n(20) Frequency: 5825

Freq. (MHz)	Ant.Pol. H/V	Field Strength (RBW=100KHz) (dBuV/m)	E.I.R.P (dBm)	Limit (dBm)	Verdict
5850	V	71.20	-24.03	-27	PASS
5851.12	H	68.71	-26.52	-27	PASS

- Note:** (1) All Readings are Peak Value (VBW=3MHz) and Peak Value (VBW=10Hz).
 (2) Emission Level= Reading Level+Correct Factor +Cable Loss.
 (3) Correct Factor= Ant_F + Cab_L - Preamp
 (4) EIRP[dBm] = E[dBμV/m] + 20 log(d[meters]) - 104.77
 d is the measurement distance in 3 meters

U-NII -3

Test Model	Undesirable radiated <input type="checkbox"/> 802.11a	Undesirable radiated <input checked="" type="checkbox"/> 5745	Spurious Emission in Band Edge <input type="checkbox"/> 802.11n(HT40)
		<input checked="" type="checkbox"/> 802.11n(HT20)	Ant.Pol <input type="checkbox"/> 802.11n(HT40)
			V

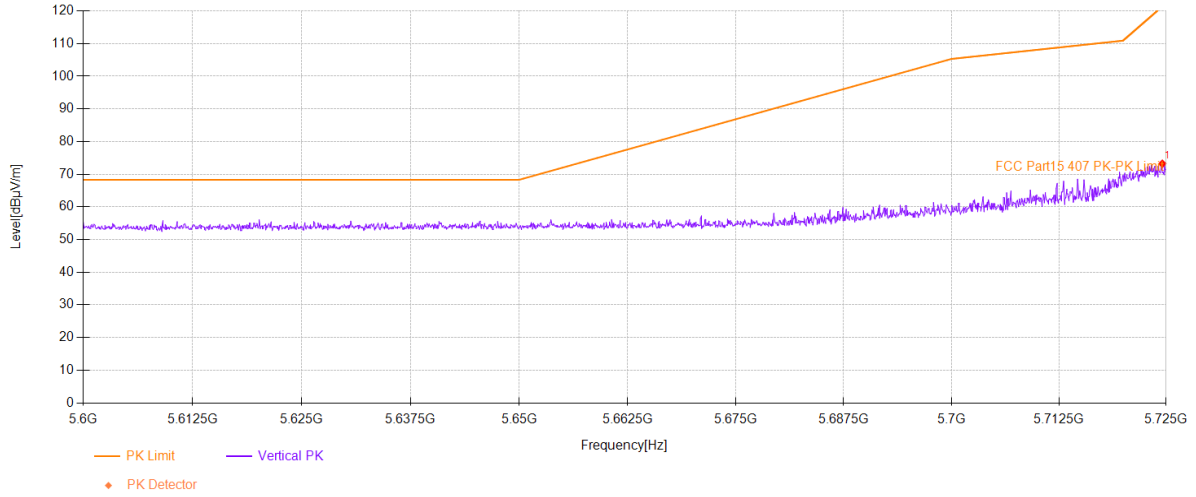

U-NII -3

Test Model	Undesirable radiated <input type="checkbox"/> 802.11a	Undesirable radiated <input checked="" type="checkbox"/> 5745	Spurious Emission in Band Edge <input type="checkbox"/> 802.11n(HT40)
		<input checked="" type="checkbox"/> 802.11n(HT20)	Ant.Pol <input type="checkbox"/> 802.11n(HT40)
			H

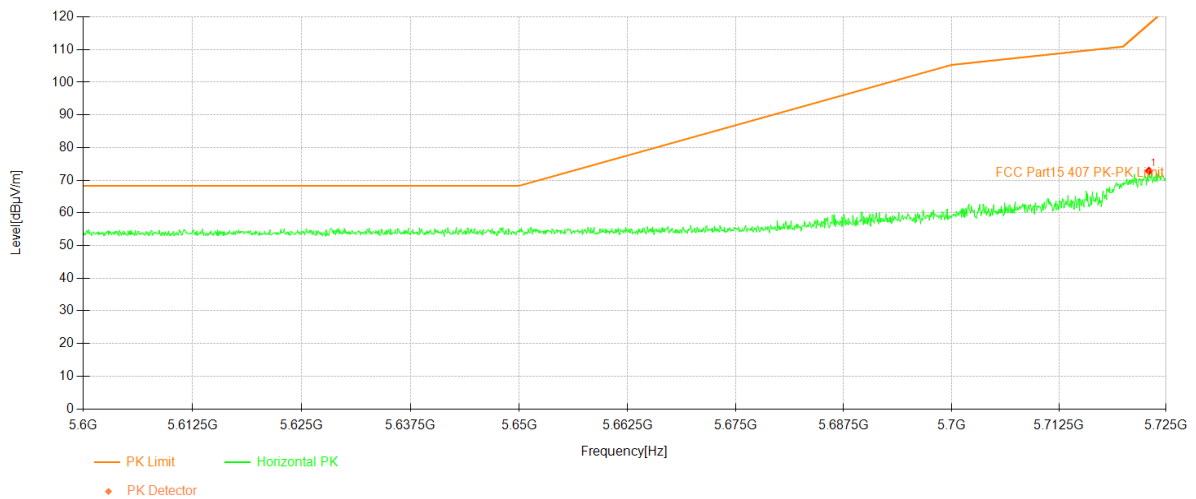

U-NII -3			
Test Model	Undesirable radiated	Undesirable radiated	Spurious Emission in Band Edge
	<input type="checkbox"/> 802.11a	<input checked="" type="checkbox"/> 802.11n(HT20)	<input type="checkbox"/> 802.11n(HT40)
	<input checked="" type="checkbox"/> 5825		Ant.Pol V

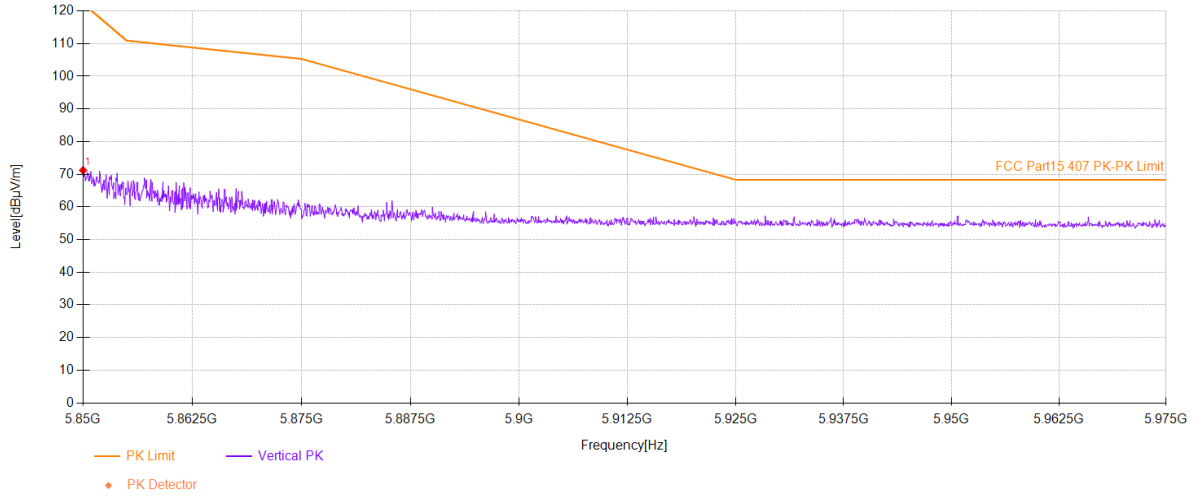

U-NII -3			
Test Model	Undesirable radiated	Undesirable radiated	Spurious Emission in Band Edge
	<input type="checkbox"/> 802.11a	<input checked="" type="checkbox"/> 802.11n(HT20)	<input type="checkbox"/> 802.11n(HT40)
	<input checked="" type="checkbox"/> 5825		Ant.Pol H

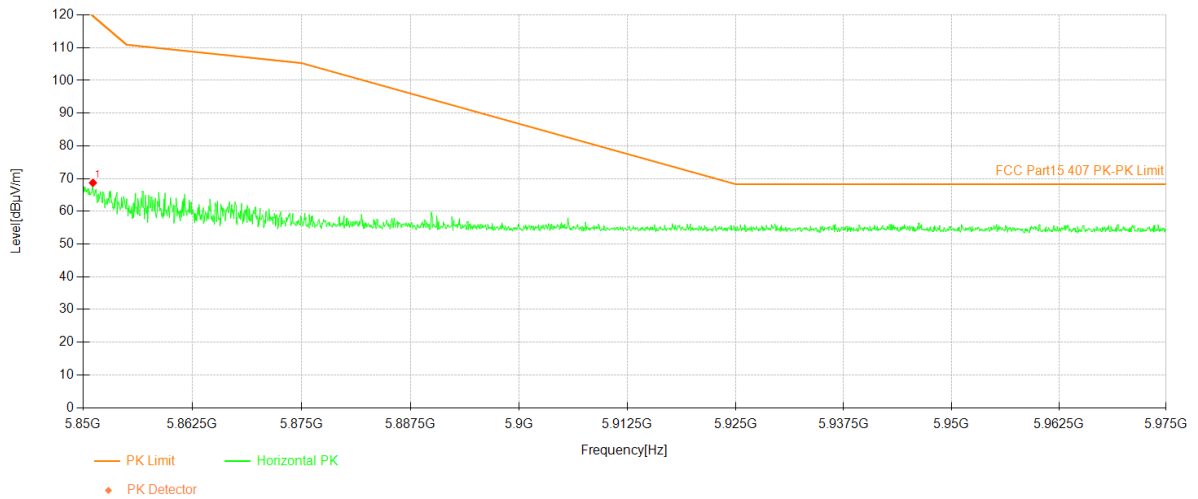

- Undesirable radiated Spurious Emission below 1GHz (30MHz to 1GHz)
All of the configurations or modes are tested, the data of the worst case is recorded in the report.

Test mode: 802.11n(20) Frequency(MHz): 5180

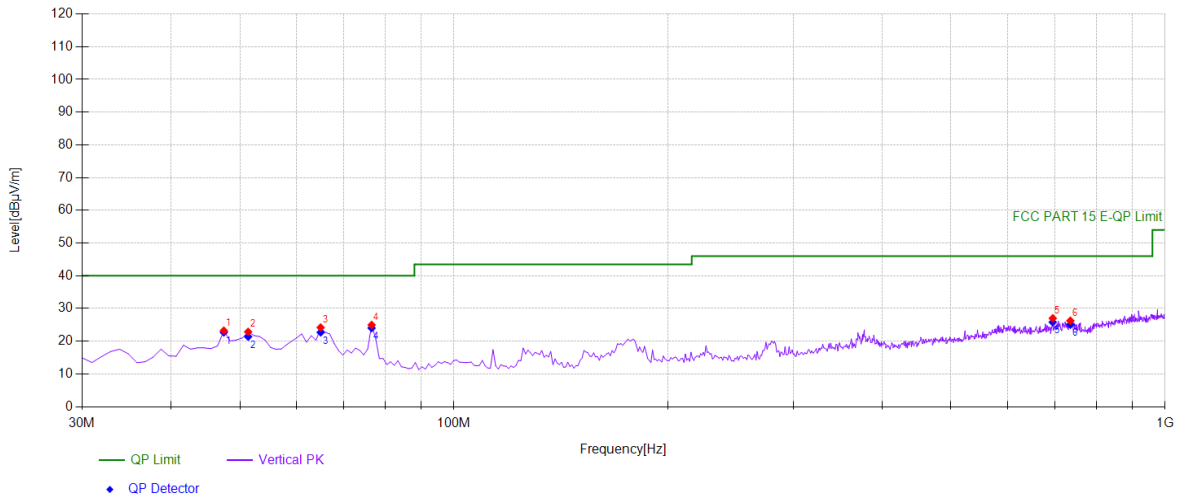

Suspected Data List								
NO.	Freq. [MHz]	Reading [dBμV]	Factor [dB/m]	Level [dBμV/m]	Detector	Limit [dBμV/m]	Margin [dB]	Polarity
1	47.4775	39.62	-16.39	23.23	PK	40.00	16.77	Vertical
2	51.3614	39.08	-16.21	22.87	PK	40.00	17.13	Vertical
3	64.955	42.26	-18.07	24.19	PK	40.00	15.81	Vertical
4	76.6066	44.74	-19.77	24.97	PK	40.00	15.03	Vertical
5	695.115	33.11	-6.10	27.01	PK	46.00	18.99	Vertical
6	735.895	31.58	-5.32	26.26	PK	46.00	19.74	Vertical

Final Data List					
NO.	Freq. [MHz]	Factor [dB/m]	QP Value [dBμV/m]	QP Limit [dBμV/m]	QP Margin [dB]
1	47.4775	-16.39	22.71	40.00	17.29
2	51.3614	-16.21	21.39	40.00	18.61
3	64.955	-18.07	22.71	40.00	17.29
4	76.6066	-19.77	24.02	40.00	15.98
5	695.1151	-6.10	25.82	46.00	20.18
6	735.8959	-5.32	25.07	46.00	20.93

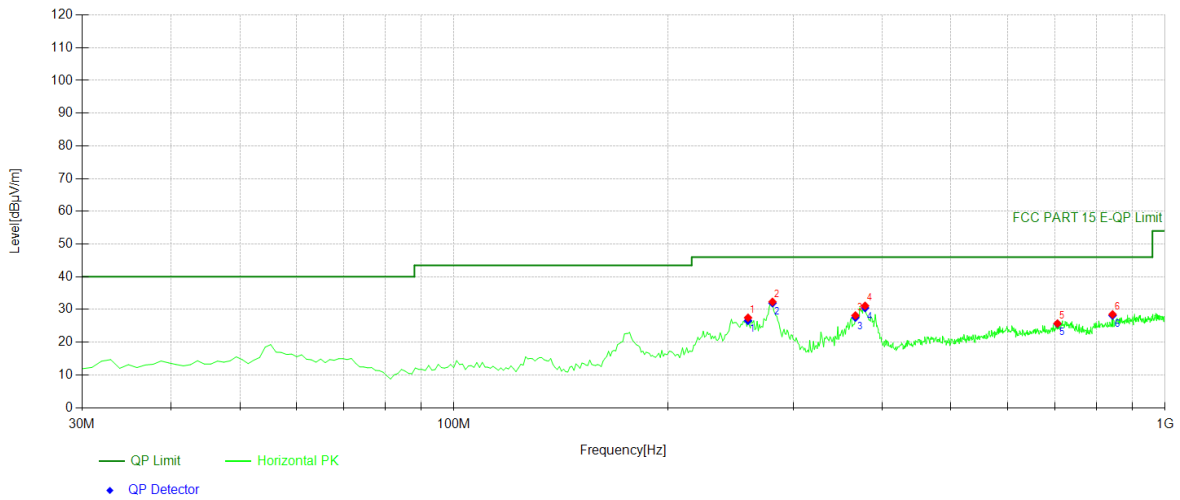

Suspected Data List								
NO.	Freq. [MHz]	Reading [dBµV]	Factor [dB/m]	Level [dBµV/m]	Detector	Limit [dBµV/m]	Margin [dB]	Polarity
1	259.149	43.18	-15.69	27.49	PK	46.00	18.51	Horizontal
2	280.510	47.12	-14.78	32.34	PK	46.00	13.66	Horizontal
3	366.926	40.19	-12.03	28.16	PK	46.00	17.84	Horizontal
4	378.578	42.71	-11.59	31.12	PK	46.00	14.88	Horizontal
5	705.795	31.55	-5.82	25.73	PK	46.00	20.27	Horizontal
6	843.673	32.68	-4.17	28.51	PK	46.00	17.49	Horizontal

Final Data List					
NO.	Freq. [MHz]	Factor [dB/m]	QP Value [dBµV/m]	QP Limit [dBµV/m]	QP Margin [dB]
1	259.1491	-15.69	26.56	46.00	19.44
2	280.5105	-14.78	31.94	46.00	14.06
3	366.9269	-12.03	27.52	46.00	18.48
4	378.5786	-11.59	30.48	46.00	15.52
5	705.7958	-5.82	25.63	46.00	20.37
6	843.6737	-4.17	28.16	46.00	17.84

Test mode: 802.11n(20) Frequency(MHz): 5200

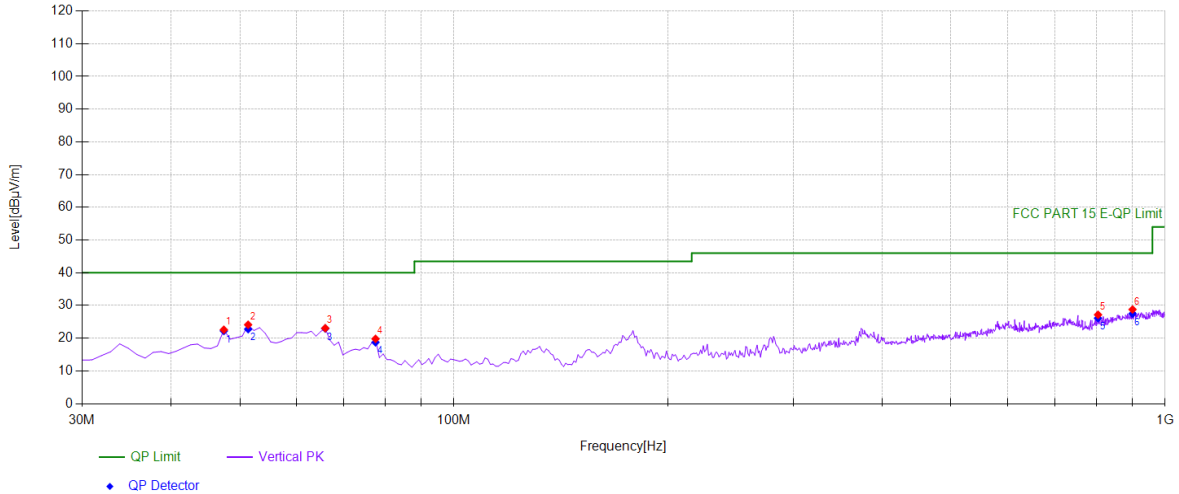

Suspected Data List								
NO.	Freq. [MHz]	Reading [dBµV]	Factor [dB/m]	Level [dBµV/m]	Detector	Limit [dBµV/m]	Margin [dB]	Polarity
1	47.4775	38.99	-16.39	22.60	PK	40.00	17.40	Vertical
2	51.3614	40.33	-16.21	24.12	PK	40.00	15.88	Vertical
3	65.9259	41.27	-18.21	23.06	PK	40.00	16.94	Vertical
4	77.5776	39.71	-19.91	19.80	PK	40.00	20.20	Vertical
5	804.834	32.16	-4.99	27.17	PK	46.00	18.83	Vertical
6	899.99	31.75	-2.96	28.79	PK	46.00	17.21	Vertical

Final Data List					
NO.	Freq. [MHz]	Factor [dB/m]	QP Value [dBµV/m]	QP Limit [dBµV/m]	QP Margin [dB]
1	47.4775	-16.39	22.22	40.00	17.78
2	51.3614	-16.21	22.77	40.00	17.23
3	65.9259	-18.21	22.97	40.00	17.03
4	77.5776	-19.91	18.75	40.00	21.25
5	804.8348	-4.99	26.12	46.00	19.88
6	899.99	-2.96	27.49	46.00	18.51

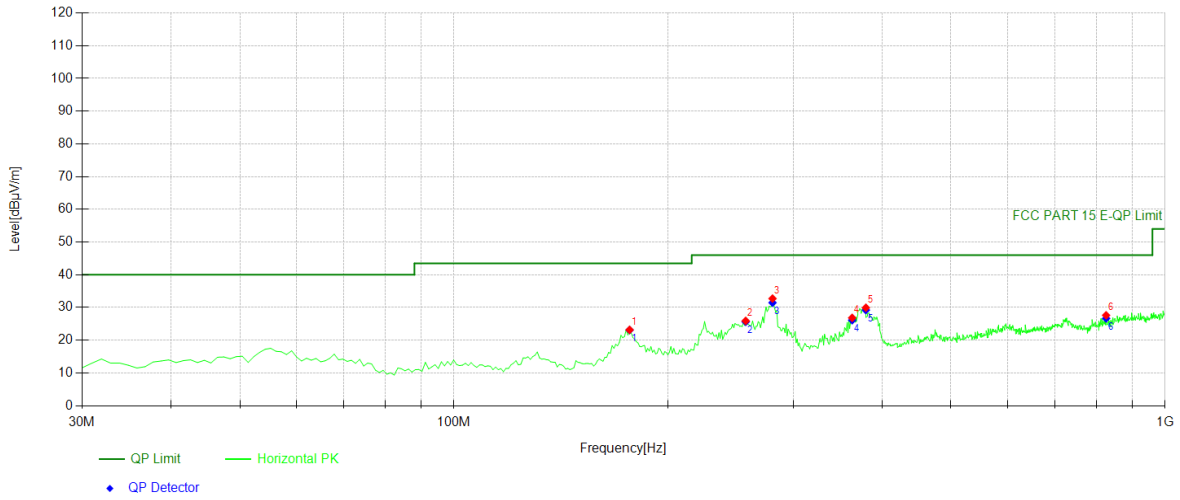

Suspected Data List								
NO.	Freq. [MHz]	Reading [dBµV]	Factor [dB/m]	Level [dBµV/m]	Detector	Limit [dBµV/m]	Margin [dB]	Polarity
1	176.616	41.90	-18.73	23.17	PK	43.50	20.33	Horizontal
2	257.207	41.63	-15.71	25.92	PK	46.00	20.08	Horizontal
3	280.510	47.51	-14.78	32.73	PK	46.00	13.27	Horizontal
4	363.043	39.04	-12.20	26.84	PK	46.00	19.16	Horizontal
5	379.549	41.49	-11.55	29.94	PK	46.00	16.06	Horizontal
6	826.196	32.25	-4.63	27.62	PK	46.00	18.38	Horizontal

Final Data List					
NO.	Freq. [MHz]	Factor [dB/m]	QP Value [dBµV/m]	QP Limit [dBµV/m]	QP Margin [dB]
1	176.6166	-18.73	23.12	43.50	20.38
2	257.2072	-15.71	25.63	46.00	20.37
3	280.5105	-14.78	31.47	46.00	14.53
4	363.043	-12.20	26.12	46.00	19.88
5	379.5496	-11.55	29.22	46.00	16.78
6	826.1962	-4.63	26.66	46.00	19.34

Test mode: 802.11n(20) Frequency(MHz): 5240

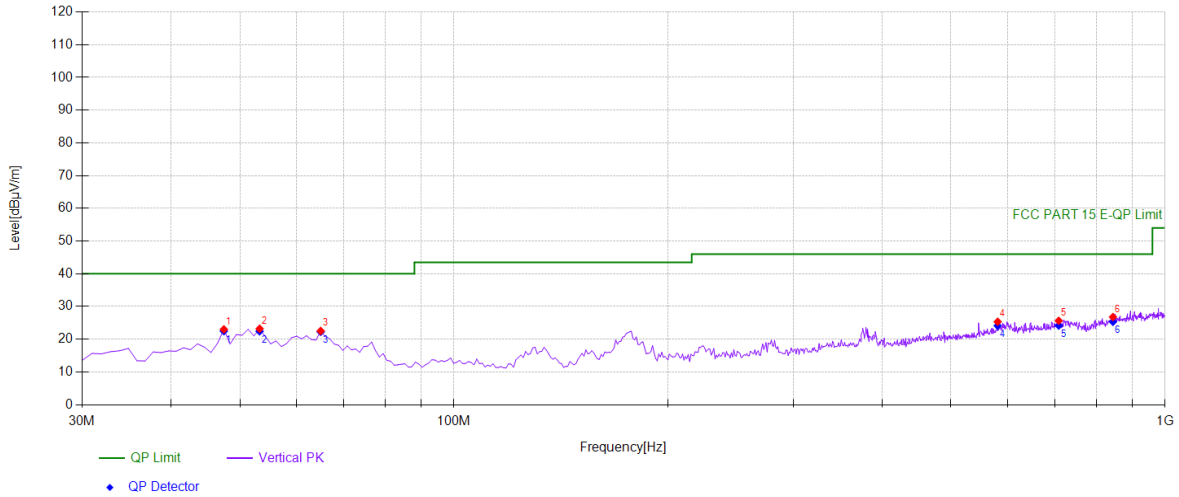

Suspected Data List								
NO.	Freq. [MHz]	Reading [dBµV]	Factor [dB/m]	Level [dBµV/m]	Detector	Limit [dBµV/m]	Margin [dB]	Polarity
1	47.4775	39.41	-16.39	23.02	PK	40.00	16.98	Vertical
2	53.3033	39.69	-16.47	23.22	PK	40.00	16.78	Vertical
3	64.955	40.60	-18.07	22.53	PK	40.00	17.47	Vertical
4	581.511	32.42	-7.08	25.34	PK	46.00	20.66	Vertical
5	708.708	31.44	-5.80	25.64	PK	46.00	20.36	Vertical
6	844.644	30.91	-4.12	26.79	PK	46.00	19.21	Vertical

Final Data List					
NO.	Freq. [MHz]	Factor [dB/m]	QP Value [dBµV/m]	QP Limit [dBµV/m]	QP Margin [dB]
1	47.4775	-16.39	22.48	40.00	17.52
2	53.3033	-16.47	22.43	40.00	17.57
3	64.955	-18.07	22.28	40.00	17.72
4	581.5115	-7.08	24.13	46.00	21.87
5	708.7087	-5.80	24.18	46.00	21.82
6	844.6446	-4.12	25.33	46.00	20.67

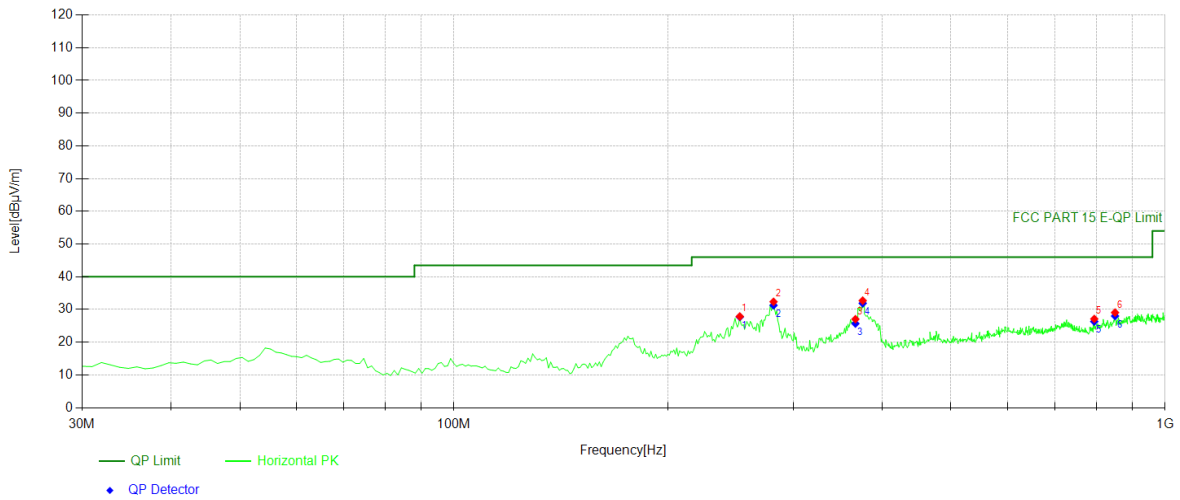

Suspected Data List								
NO.	Freq. [MHz]	Reading [dBµV]	Factor [dB/m]	Level [dBµV/m]	Detector	Limit [dBµV/m]	Margin [dB]	Polarity
1	252.352	43.61	-15.74	27.87	PK	46.00	18.13	Horizontal
2	281.481	47.09	-14.73	32.36	PK	46.00	13.64	Horizontal
3	366.926	39.08	-12.03	27.05	PK	46.00	18.95	Horizontal
4	375.665	44.41	-11.70	32.71	PK	46.00	13.29	Horizontal
5	795.125	32.70	-5.57	27.13	PK	46.00	18.87	Horizontal
6	850.470	32.88	-3.82	29.06	PK	46.00	16.94	Horizontal

Final Data List					
NO.	Freq. [MHz]	Factor [dB/m]	QP Value [dBµV/m]	QP Limit [dBµV/m]	QP Margin [dB]
1	252.3524	-15.74	27.73	46.00	18.27
2	281.4815	-14.73	31.26	46.00	14.74
3	366.9269	-12.03	25.70	46.00	20.30
4	375.6657	-11.70	31.90	46.00	14.10
5	795.1251	-5.57	26.32	46.00	19.68
6	850.4705	-3.82	28.01	46.00	17.99

8.5 POWER LINE CONDUCTED EMISSIONS

8.5.1 Applicable Standard

According to FCC Part 15.207(a)

8.5.2 Conformance Limit

Frequency(MHz)	Conducted Emission Limit	
	Quasi-peak	Average
0.15-0.5	66-56	56-46
0.5-5.0	56	46
5.0-30.0	60	50

Note: 1. The lower limit shall apply at the transition frequencies
 2. The limit decreases in line with the logarithm of the frequency in the range of 0.15 to 0.50MHz.

8.5.3 Test Configuration

Test according to clause 6.3 conducted emission test setup

8.5.4 Test Procedure

The EUT was placed on a table which is 0.8m above ground plane.
 Maximum procedure was performed on the highest emissions to ensure EUT compliance.
 Repeat above procedures until all frequency measured were complete.

8.5.5 Test Results

Temperature :	25.1℃	ATM Pressure::	1011 mbar
Humidity :	45 %	Test Engineer:	XZC

Pass

The all voltage have been tested, and the worst result recorded was report as below.

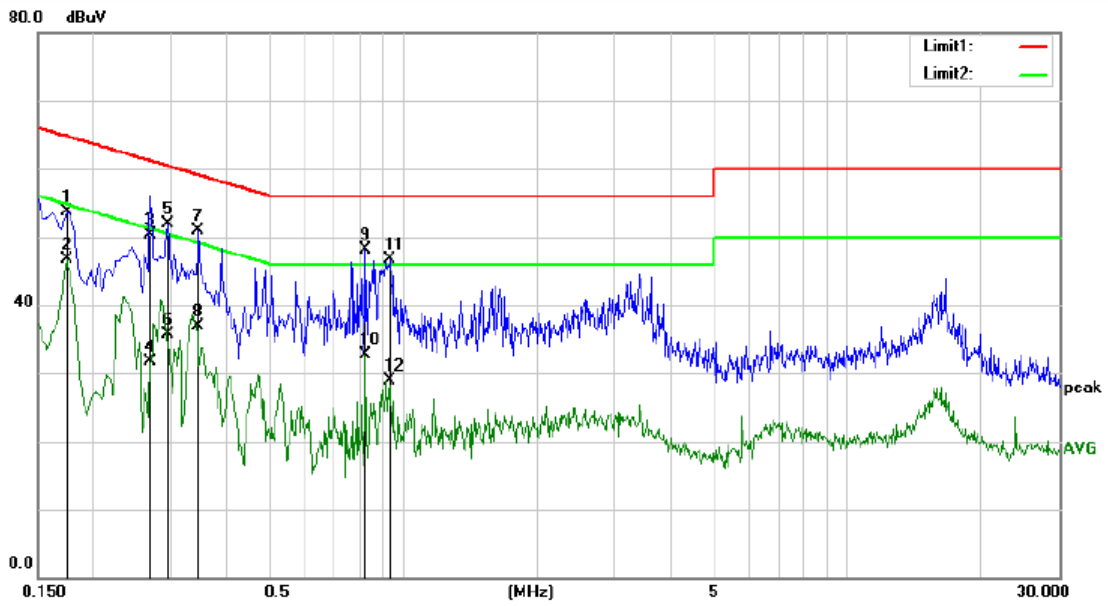

Site Conduction 2#

Phase: **N**

Temperature: 25.5

No.	Mk.	Freq.	Reading Level	Correct Factor	Measurement	Limit	Over	Detector	Comment
		MHz	dBuV	dB	dBuV	dBuV	dB		
1		0.1740	42.99	10.68	53.67	64.77	-11.10	QP	
2		0.1740	36.04	10.68	46.72	54.77	-8.05	AVG	
3		0.2700	39.61	10.69	50.30	61.12	-10.82	QP	
4		0.2700	20.97	10.69	31.66	51.12	-19.46	AVG	
5		0.2940	41.21	10.69	51.90	60.41	-8.51	QP	
6		0.2940	25.05	10.69	35.74	50.41	-14.67	AVG	
7		0.3460	40.21	10.70	50.91	59.06	-8.15	QP	
8		0.3460	26.13	10.70	36.83	49.06	-12.23	AVG	
9	*	0.8260	37.40	10.75	48.15	56.00	-7.85	QP	
10		0.8260	21.87	10.75	32.62	46.00	-13.38	AVG	
11		0.9340	35.84	10.77	46.61	56.00	-9.39	QP	
12		0.9340	18.07	10.77	28.84	46.00	-17.16	AVG	

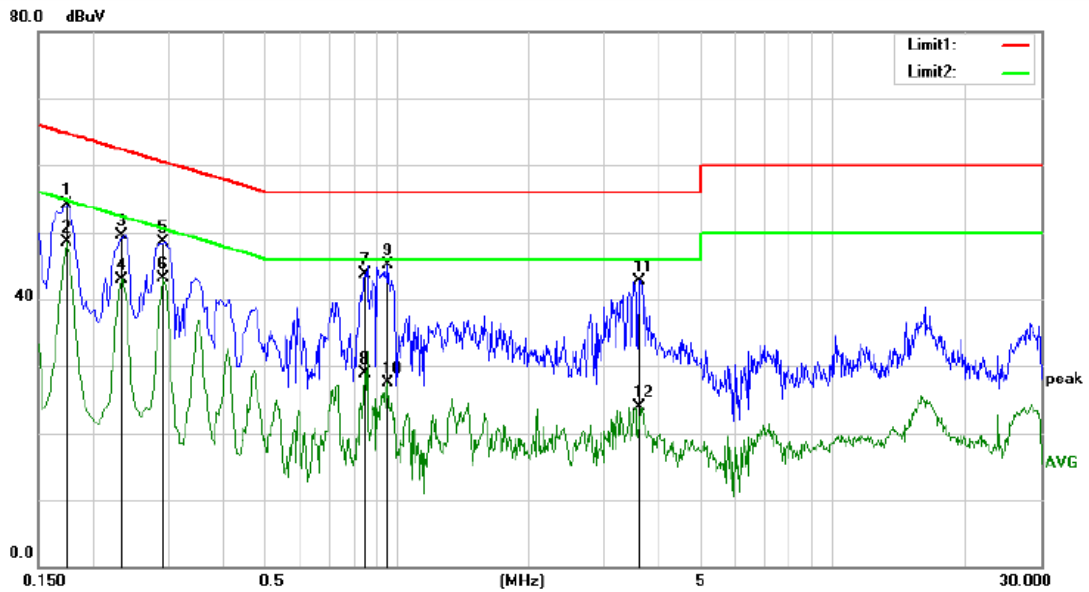

Site Conduction 2#

Phase: L1

Temperature: 25.5

No.	Mk.	Freq. MHz	Reading Level dBuV	Correct Factor dB	Measure- ment dBuV	Limit dBuV	Over dB	Detector	Comment
1		0.1740	43.44	10.68	54.12	64.77	-10.65	QP	
2	*	0.1740	37.74	10.68	48.42	54.77	-6.35	AVG	
3		0.2340	38.92	10.67	49.59	62.31	-12.72	QP	
4		0.2340	32.24	10.67	42.91	52.31	-9.40	AVG	
5		0.2900	37.80	10.69	48.49	60.52	-12.03	QP	
6		0.2900	32.38	10.69	43.07	50.52	-7.45	AVG	
7		0.8460	33.01	10.75	43.76	56.00	-12.24	QP	
8		0.8460	18.13	10.75	28.88	46.00	-17.12	AVG	
9		0.9580	34.25	10.77	45.02	56.00	-10.98	QP	
10		0.9580	16.67	10.77	27.44	46.00	-18.56	AVG	
11		3.6020	32.10	10.60	42.70	56.00	-13.30	QP	
12		3.6020	13.29	10.60	23.89	46.00	-22.11	AVG	

8.6 ANTENNA APPLICATION

8.6.1 Antenna Requirement

Standard	Requirement
FCC CRF Part 15.203	An intentional radiator shall be designed to ensure that no antenna other than that furnished by the responsible party shall be used with the device. The use of a permanently attached antenna or of an antenna that uses a unique coupling to the intentional radiator shall be considered sufficient to comply with the provisions of this section. The manufacturer may design the unit so that a broken antenna can be replaced by the user, but the use of a standard antenna jack or electrical connector is prohibited. This requirement does not apply to carrier current devices or to devices operated under the provisions of §15.211, §15.213, §15.217, §15.219, or §15.221. Further, this requirement does not apply to intentional radiators that must be professionally installed, such as perimeter protection systems and some field disturbance sensors, or to other intentional radiators which, in accordance with §15.31(d), must be measured at the installation site. However, the installer shall be responsible for ensuring that the proper antenna is employed so that the limits in this part are not exceeded.

For intentional device, according to FCC 47 CFR Section 15.203, an intentional radiator shall be designed to ensure that no antenna other than that furnished by the responsible party shall be used with the device. And according to FCC 47 CFR Section 15.407 (a), if transmitting antennas of directional gain greater than 6dBi are used, the power shall be reduced by the amount in dB that the directional gain of the antenna exceeds 6dBi.

8.6.2 Result

Temperature : 25°C ATM Pressure:: 1011 mbar
Humidity : 60 % Test Engineer: XXH

PASS

The EUT is integrated antenna, Ant1: 0.89dBi, Ant2: 2.75dBi

- Antennas use a permanently attached antenna which is not replaceable.
- Not using a standard antenna jack or electrical connector for antenna replacement
- The antenna has to be professionally installed (please provide method of installation)

Which in accordance to section 15.203, please refer to the internal photos.

Detail of factor for radiated emission:

Frequency(MHz)	Ant_F(dB)	Cab_L(dB)	Preamp(dB)	Correct Factor(dB)
0.009	20.6	0.03	\	20.63
0.15	20.7	0.1	\	20.8
1	20.9	0.15	\	21.05
10	20.1	0.28	\	20.38
30	18.8	0.45	\	19.25
30	11.7	0.62	27.9	-15.58
100	12.5	1.02	27.8	-14.28
300	12.9	1.91	27.5	-12.69
600	19.2	2.92	27	-4.88
800	21.1	3.54	26.6	-1.96
1000	22.3	4.17	26.2	0.27
1000	25.6	1.76	41.4	-14.04
3000	28.9	3.27	43.2	-11.03
5000	31.1	4.2	44.6	-9.3
8000	36.2	5.95	44.7	-2.55
10000	38.4	6.3	43.9	0.8
12000	38.5	7.14	42.3	3.34
15000	40.2	8.15	41.4	6.95
18000	45.4	9.02	41.3	13.12
18000	37.9	1.81	47.9	-8.19
21000	37.9	1.95	48.7	-8.85
25000	39.3	2.01	42.8	-1.49
28000	39.6	2.16	46.0	-4.24
31000	41.2	2.24	44.5	-1.06
34000	41.5	2.29	46.6	-2.81
37000	43.8	2.30	46.4	-0.3
40000	43.2	2.50	42.2	3.5

--- End of Report ---

声明

Statement

1. 本报告无授权批准人签字及“检验检测专用章”无效。
1. This report is invalid without the signature of the authorized approver and "special seal for testing".
2. 未经许可本报告不得部分复制。
2. This report shall not be copied partly without authorization.
3. 本报告的检测结果仅对送测样品有效，委托方对样品的代表性和资料的真实性负责。
3. The test results or observations are applicable only to tested sample. Client shall be responsible for representativeness of the sample and authenticity of the material.
4. 本检测报告中检测项目标注有特殊符号则该项目不在资质认定范围内，仅作为客户委托、科研、教学或内部质量控制等目的使用。
4. The observations or tests with special mark fall outside the scope of accreditation, and are only used for purpose of commission, research, training, internal quality control etc.
5. 本检测报告以实测值进行符合性判定，未考虑不确定度所带来的风险，本实验室不承担相关责任，特别约定、标准或规范中有明确规定的除外。
5. The test results or observations are provided in accordance with measured value, without taking risks caused by uncertainty into account. Without explicit stipulation in special agreements, standards or regulations, EMTEK shall not assume any responsibility.
6. 对本检验报告若有异议，请于收到报告之日起 20 日内提出。
6. Objections shall be raised within 20 days from the date receiving the report.