

RF TEST REPORT

Applicant Shanghai Xiangcheng Communication
Technology Co., Ltd

FCC ID 2A2UU-PEGASUS1

Product Pegasus1

Model Pegasus1

Report No. EFTA25040240-IE-07-R2V1

Issue Date June 17, 2025

Eurofins TA Technology (Shanghai) Co., Ltd. tested the above equipment in accordance with the requirements in **FCC CFR47 Part 15C (2024)**. The test results show that the equipment tested is capable of demonstrating compliance with the requirements as documented in this report.

Prepared by: Xu Ying

Approved by: Xu Kai

Eurofins TA Technology (Shanghai) Co., Ltd.

Building 3, No.145, Jintang Rd, Pudong Shanghai, P.R.China

TEL: +86-021-50791141/2/3

FAX: +86-021-50791141/2/3-8000

TABLE OF CONTENT

1. Test Laboratory	5
1.1. Notes of the Test Report.....	5
1.2. Test Facility	5
1.3. Testing Location.....	5
2. General Description of Equipment Under Test.....	6
2.1. Applicant and Manufacturer Information	6
2.2. General Information	6
3. Applied Standards.....	8
4. Test Configuration.....	9
5. Test Case Results.....	10
5.1. Maximum output power	10
5.2. 99% Bandwidth and 6dB Bandwidth	13
5.3. Band Edge	33
5.4. Power Spectral Density	46
5.5. Spurious RF Conducted Emissions.....	58
5.6. Unwanted Emission	78
5.7. Conducted Emission.....	119
6. Main Test Instruments.....	124
ANNEX A: The EUT Appearance.....	125
ANNEX B: Test Setup Photos.....	126

Version	Revision Description	Issue Date
Rev.0	Initial issue of report.	June 4, 2025
Rev.1	Updated information.	June 17, 2025

Note: This revised report (Report No.: EFTA25040240-IE-07-R2V1) supersedes and replaces the previously issued report (Report No.: EFTA25040240-IE-07-R2). Please discard or destroy the previously issued report and dispose of it accordingly.

Summary of Measurement Results

Number	Test Case	Clause in FCC rules	Verdict
1	Maximum output power	15.247(b)(3)	PASS
2	99% Bandwidth and 6dB Bandwidth	15.247(a)(2) C63.10 6.9	PASS
3	Power spectral density	15.247(e)	PASS
4	Band Edge	15.247(d)	PASS
5	Spurious RF Conducted Emissions	15.247(d)	PASS
6	Unwanted Emissions	15.247(d), 15.205, 15.209	PASS
7	Conducted Emissions	15.207	PASS
Date of Testing: April 29, 2025 ~May 13, 2025			
Date of Sample Received: April 25, 2025			
Note: All indications of Pass/Fail in this report are opinions expressed by Eurofins TA Technology (Shanghai) Co., Ltd. based on interpretations and/or observations of test results. Measurement Uncertainties were not taken into account and are published for informational purposes only.			

1. Test Laboratory

1.1. Notes of the Test Report

This report shall not be reproduced in full or partial, without the written approval of **Eurofins TA Technology (Shanghai) Co., Ltd.** The results documented in this report apply only to the tested sample, under the conditions and modes of operation as described herein. Measurement Uncertainties were not taken into account and are published for informational purposes only. This report is written to support regulatory compliance of the applicable standards stated above.

1.2. Test Facility

FCC (Designation number: CN1179, Test Firm Registration Number: 446626)

Eurofins TA Technology (Shanghai) Co., Ltd. has been listed on the US Federal Communications Commission list of test facilities recognized to perform measurements.

A2LA (Certificate Number: 3857.01)

Eurofins TA Technology (Shanghai) Co., Ltd. has been listed by American Association for Laboratory Accreditation to perform measurement.

1.3. Testing Location

Company: Eurofins TA Technology (Shanghai) Co., Ltd.
Address: Building 3, No.145, Jintang Rd, Pudong Shanghai, P.R.China
City: Shanghai
Post code: 201201
Country: P. R. China
Contact: Xu Kai
Telephone: +86-021-50791141/2/3
Fax: +86-021-50791141/2/3-8000
Website: <https://www.eurofins.com/electrical-and-electronics>
E-mail: Kain.Xu@cpt.eurofinscn.com

2. General Description of Equipment Under Test

2.1. Applicant and Manufacturer Information

Applicant	Shanghai Xiangcheng Communication Technology Co., Ltd
Applicant address	6th Floor, Building 10, No.3000 Longdong Avenue, Pudong New District, Shanghai, China
Manufacturer	Shanghai Xiangcheng Communication Technology Co., Ltd
Manufacturer address	6th Floor, Building 10, No.3000 Longdong Avenue, Pudong New District, Shanghai, China

2.2. General Information

EUT Description		
Model	Pegasus1	
SN	Conducted	K0161A1X253UD20107
	Radiated	K0161A1X253UD20128
Hardware Version	V1.0	
Software Version	V1.0	
Power Supply	AC adapter	
Antenna Type	PCB Antenna	
Antenna Connector	A permanently attached antenna (meet with the standard FCC Part 15.203 requirement)	
Antenna Gain	Wi-Fi 2.4G: 2.19 dBi	
	Bluetooth LE: 1.99 dBi	
Additional Beamforming Gain	NA	
Operating Frequency Range(s)	802.11b/g/n(HT20): 2412 ~ 2462 MHz	
	802.11n(HT40): 2422 ~ 2452 MHz	
	Bluetooth LE V5.0: 2402 ~2480 MHz	
Modulation Type	802.11b: DSSS	
	802.11g/n: OFDM	
	Bluetooth LE: GFSK	
Max. Output Power	Wi-Fi 2.4GHz: 16.16 dBm	
	Bluetooth LE: -3.00 dBm	
Operating voltage range	21.6 Vdc to 26.4 Vdc	
State voltage	24 Vdc	
EUT Accessory		
Adapter	Manufacturer: Hunan Dajing Power Technology Co., Ltd. Model: ADP-60D24	
AC Cable	Manufacturer: Zhengyu Electronic Co., Ltd.	

	Model: C393-240909-001
--	------------------------

Note: 1. The EUT is sent from the applicant to Eurofins TA and the information of the EUT is declared by the applicant.

3. Applied Standards

According to the specifications of the manufacturer, it must comply with the requirements of the following standards:

Test standards:

FCC CFR47 Part 15C (2024) Radio Frequency Devices

ANSI C63.10-2013

Reference standard:

KDB 558074 D01 15.247 Meas Guidance v05r02

4. Test Configuration

Test Mode

The EUT has been associated with peripherals and configuration operated in a manner tended to maximize its emission characteristics in a typical application.

The radiated emission was measured in the following position: EUT stand-up position (Z axis), lie-down position (X, Y axis). The worst emission was found in lie-down position (X axis) and the loop antenna is vertical, the others are vertical and horizontal. and the worst case was recorded.

In order to find the worst case condition, Pre-tests are needed at the presence of different data rate. Preliminary tests have been done on all the configuration for confirming worst case. Data rate below means worst-case rate of each test item.

Worst-case data rates are shown as following table.

Test Mode	Data Rate
Bluetooth (Low Energy)	1Mbps; 2Mbps
802.11b	1 Mbps
802.11g	6 Mbps
802.11n HT20	MCS0
802.11n HT40	MCS0

5. Test Case Results

5.1. Maximum output power

Ambient Condition

Temperature	Relative humidity
15°C ~ 35°C	20% ~ 80%

Methods of Measurement

During the process of the testing, The EUT was connected to Power meter with a known loss. The EUT is max power transmission with proper modulation.

Test Setup

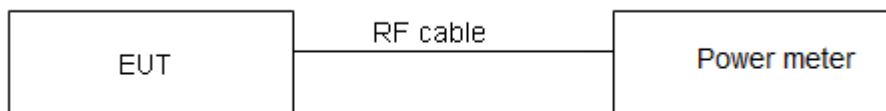

Limits

Rule Part 15.247 (b) (3) specifies that " For systems using digital modulation in the 902–928 MHz, 2400–2483.5 MHz: 1 Watt."

Average Output Power	$\leq 1\text{W (30dBm)}$
----------------------	--------------------------

Measurement Uncertainty

The assessed measurement uncertainty to ensure 95% confidence level for the normal distribution is with the coverage factor $k = 2$, $U = 0.44$ dB.

Test Results

Power Index					
Channel	802.11b	802.11g	802.11n HT20	Channel	802.11n HT40
CH1	18	16	14	CH3	14
CH6	18	16	14	CH6	14
CH11	18	16	14	CH9	14

Power Index			
Bluetooth (Low Energy)			
Channel	1M	Channel	2M
CH0	Default	CH1	Default
CH19	Default	CH19	Default
CH39	Default	CH38	Default

Test Mode	Duty cycle	Duty cycle correction Factor (dB)
802.11b	1.000	0.00
802.11g	0.975	0.11
802.11n HT20	0.973	0.12
802.11n HT40	0.947	0.23
Bluetooth LE (1M)	0.850	0.70
Bluetooth LE (2M)	0.317	4.99

Note: when Duty cycle ≥ 0.98 , Duty cycle correction Factor not required.

Test Mode	Carrier frequency (MHz)/ Channel	Average Power Measured (dBm)	Average Power with duty factor (dBm)	Limit (dBm)	Conclusion
802.11b	2412/CH 1	15.75	15.75	30	PASS
	2437/CH 6	16.16	16.16	30	PASS
	2462/CH11	15.93	15.93	30	PASS
802.11g	2412/CH 1	13.90	14.01	30	PASS
	2437/CH 6	13.84	13.95	30	PASS
	2462/CH11	13.88	13.99	30	PASS
802.11n HT20	2412/CH 1	11.90	12.01	30	PASS
	2437/CH 6	11.78	11.90	30	PASS
	2462/CH11	11.78	11.90	30	PASS
802.11n HT40	2422/CH3	12.05	12.29	30	PASS
	2437/CH6	11.99	12.22	30	PASS
	2452/CH9	11.90	12.14	30	PASS
Bluetooth (Low Energy) (1M)	2402/CH0	-3.96	-3.26	30	PASS
	2440/CH19	-3.85	-3.15	30	PASS
	2480/CH39	-5.32	-4.62	30	PASS
Bluetooth (Low Energy) (2M)	2404/CH1	-7.99	-3.00	30	PASS
	2440/CH19	-8.08	-3.09	30	PASS
	2478/CH38	-8.12	-3.13	30	PASS
Note: Average Power with duty factor = Average Power Measured +Duty cycle correction factor					

5.2. 99% Bandwidth and 6dB Bandwidth

Ambient Condition

Temperature	Relative humidity
15°C ~ 35°C	20% ~ 80%

Method of Measurement

The EUT was connected to the spectrum analyzer through an external attenuator (20dB) and a known loss cable. RBW is set to 100 kHz; VBW is set to 300 kHz on spectrum analyzer. Dector=Peak, Trace mode=max hold.

The EUT was connected to the spectrum analyzer through a known loss cable. The resolution bandwidth (RBW) shall be in the range of 1% to 5% of the actual occupied / x dB bandwidth and the video bandwidth (VBW) shall not be smaller than three times the RBW value.

Test Setup

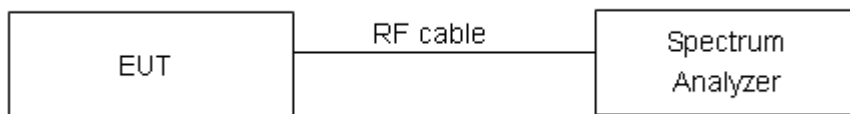

Limits

Rule Part 15.247 (a) (2) specifies that “Systems using digital modulation techniques may operate in the 902–928 MHz, 2400–2483.5 MHz bands. The minimum 6 dB bandwidth shall be at least 500 kHz.”

minimum 6 dB bandwidth	≥ 500 kHz
------------------------	-----------

Measurement Uncertainty

The assessed measurement uncertainty to ensure 95% confidence level for the normal distribution is with the coverage factor $k = 2$, $U = 936$ Hz.

Test Results:

Test Mode	Carrier frequency (MHz)/ Channel	99% bandwidth (MHz)	Minimum 6 dB bandwidth (MHz)	Limit (kHz)	Conclusion
802.11b	2412/CH 1	13.099	8.015	500	PASS
	2437/CH 6	13.096	8.057	500	PASS
	2462/CH11	13.050	8.556	500	PASS
802.11g	2412/CH 1	16.588	15.096	500	PASS
	2437/CH 6	16.608	16.248	500	PASS
	2462/CH11	16.608	15.060	500	PASS
802.11n HT20	2412/CH 1	17.639	15.927	500	PASS
	2437/CH 6	17.669	14.968	500	PASS
	2462/CH11	17.680	16.285	500	PASS
802.11n HT40	2422/CH3	36.075	33.889	500	PASS
	2437/CH6	36.045	35.112	500	PASS
	2452/CH9	36.125	33.874	500	PASS
Bluetooth (Low Energy) (1M)	2402/CH0	1.043	0.678	500	PASS
	2440/CH19	1.040	0.657	500	PASS
	2480/CH39	1.041	0.684	500	PASS
Bluetooth (Low Energy) (2M)	2404/CH1	2.068	1.171	500	PASS
	2440/CH19	2.070	1.130	500	PASS
	2478/CH38	2.057	1.144	500	PASS

99%bandwidth

OBW 802.11b 2412MHz

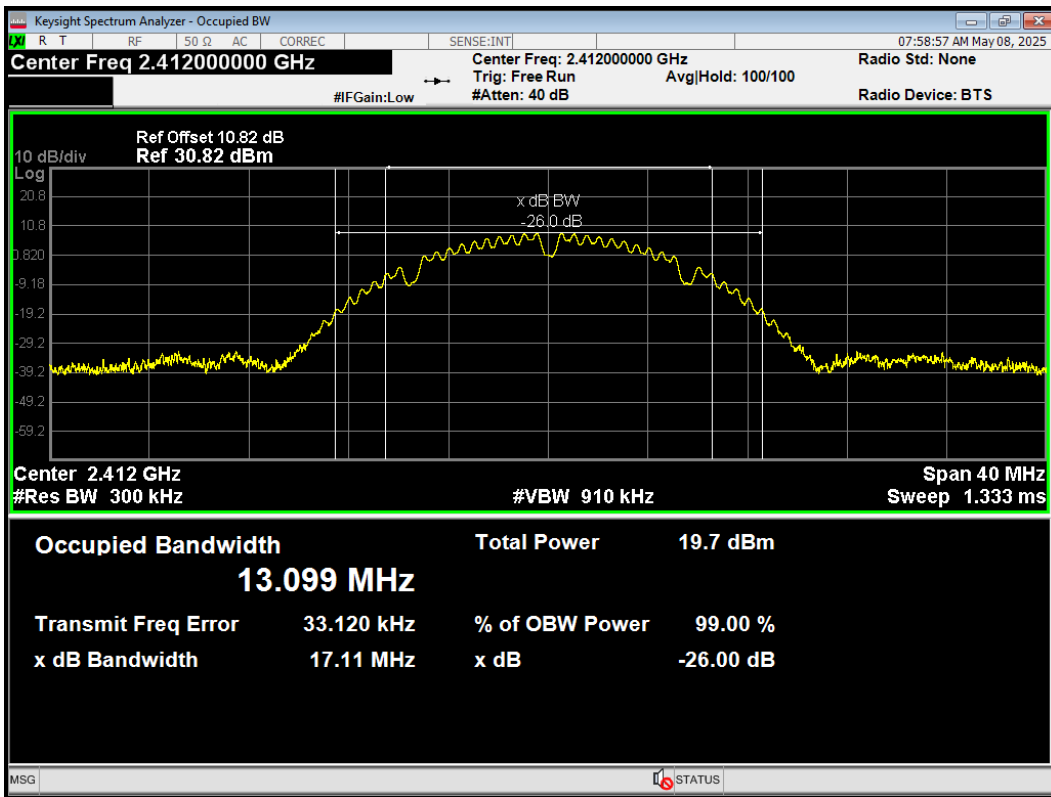

OBW 802.11b 2437MHz

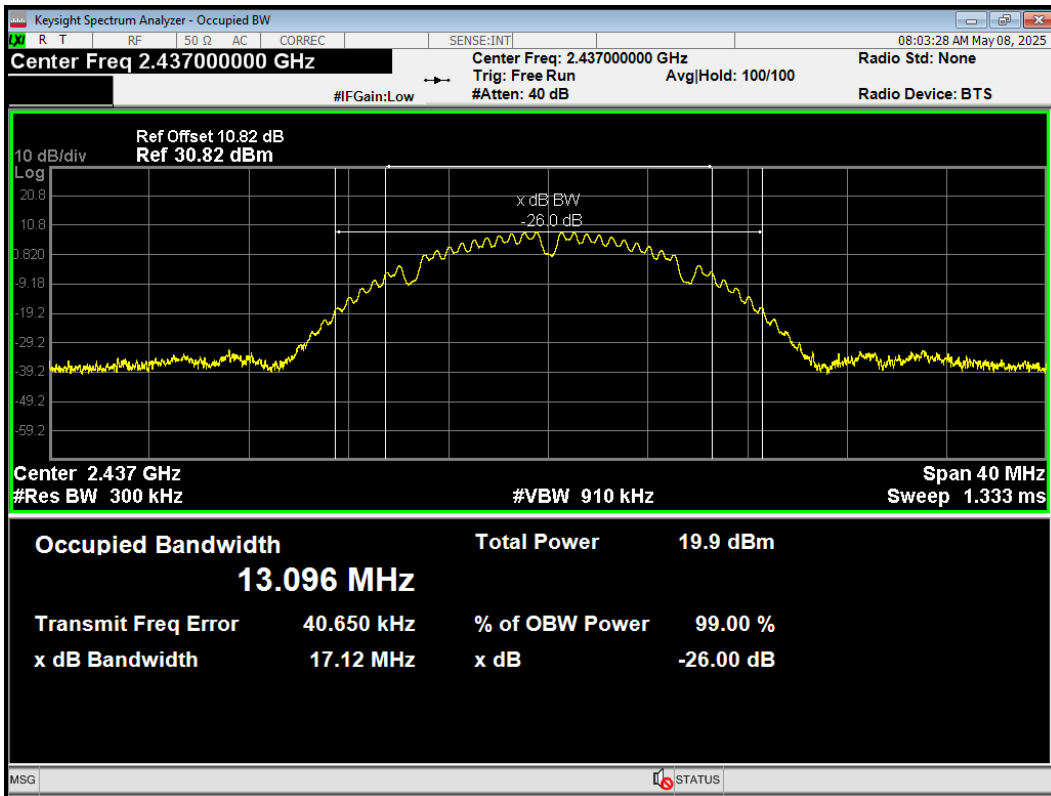

OBW 802.11b 2462MHz

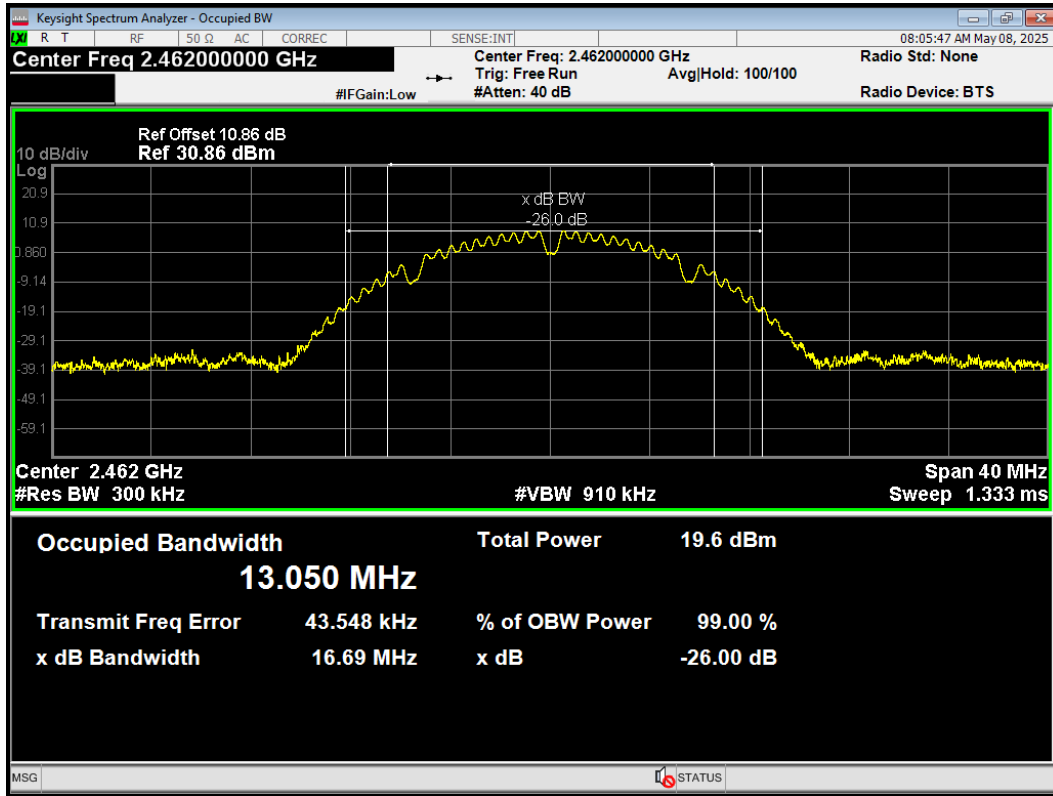

OBW 802.11g 2412MHz

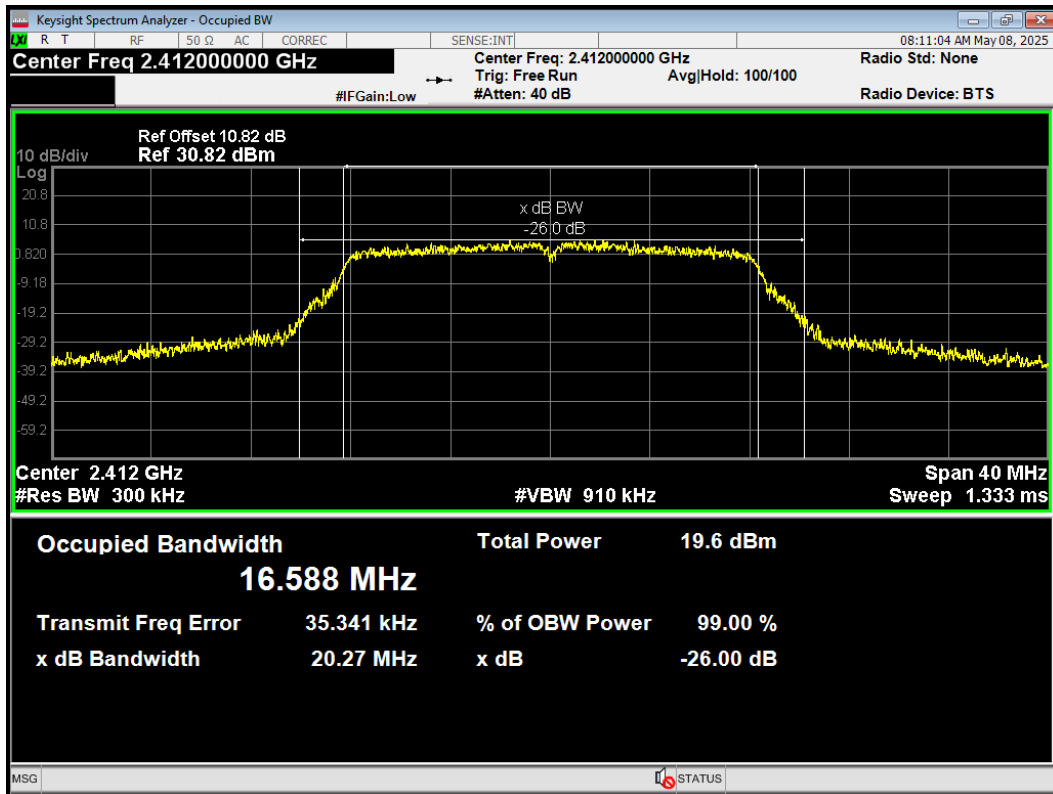

OBW 802.11g 2437MHz

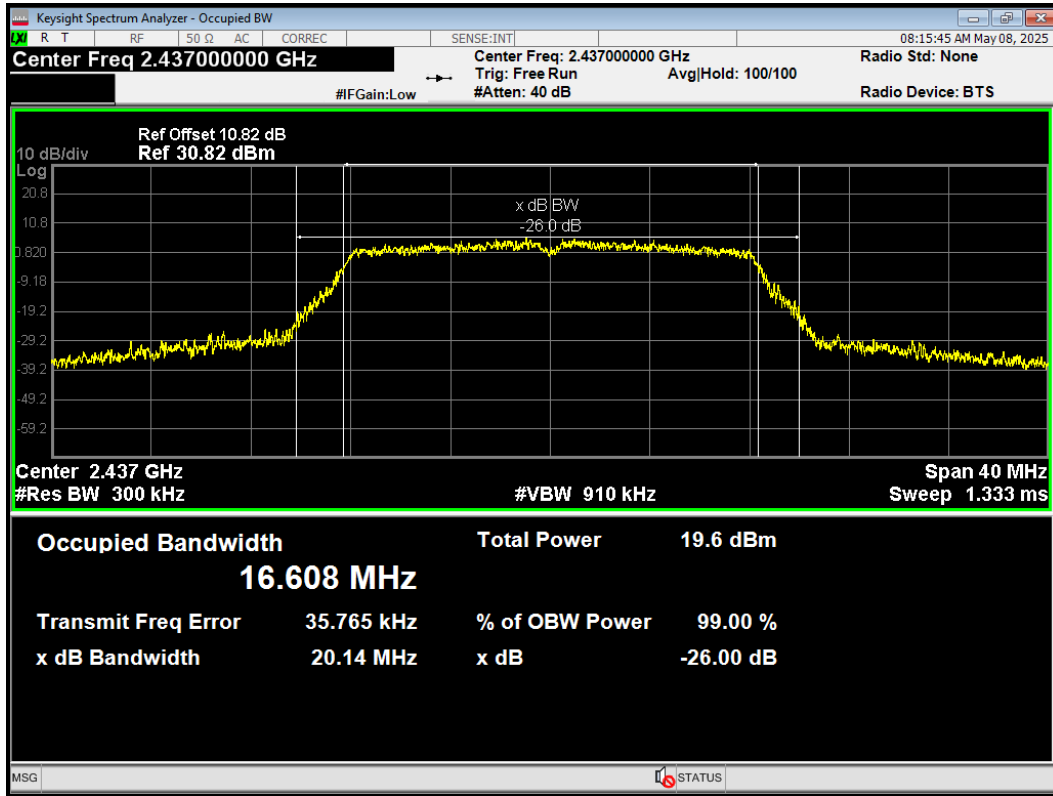

OBW 802.11g 2462MHz

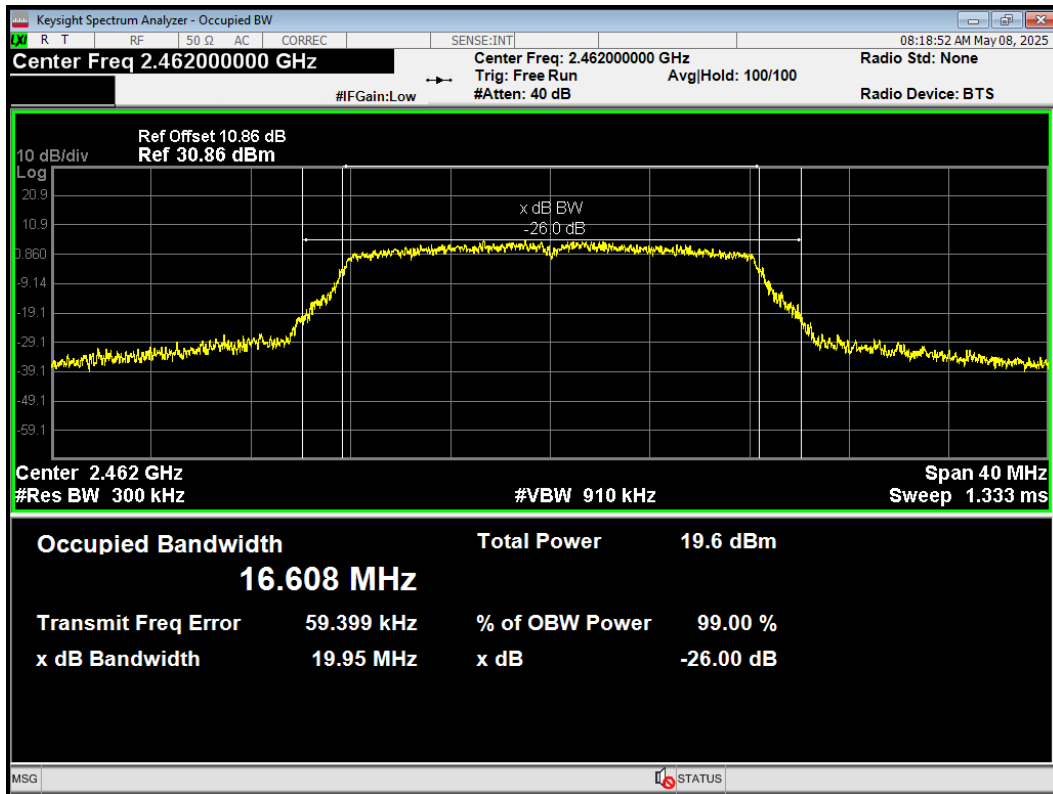

OBW 802.11n(HT20) 2412MHz

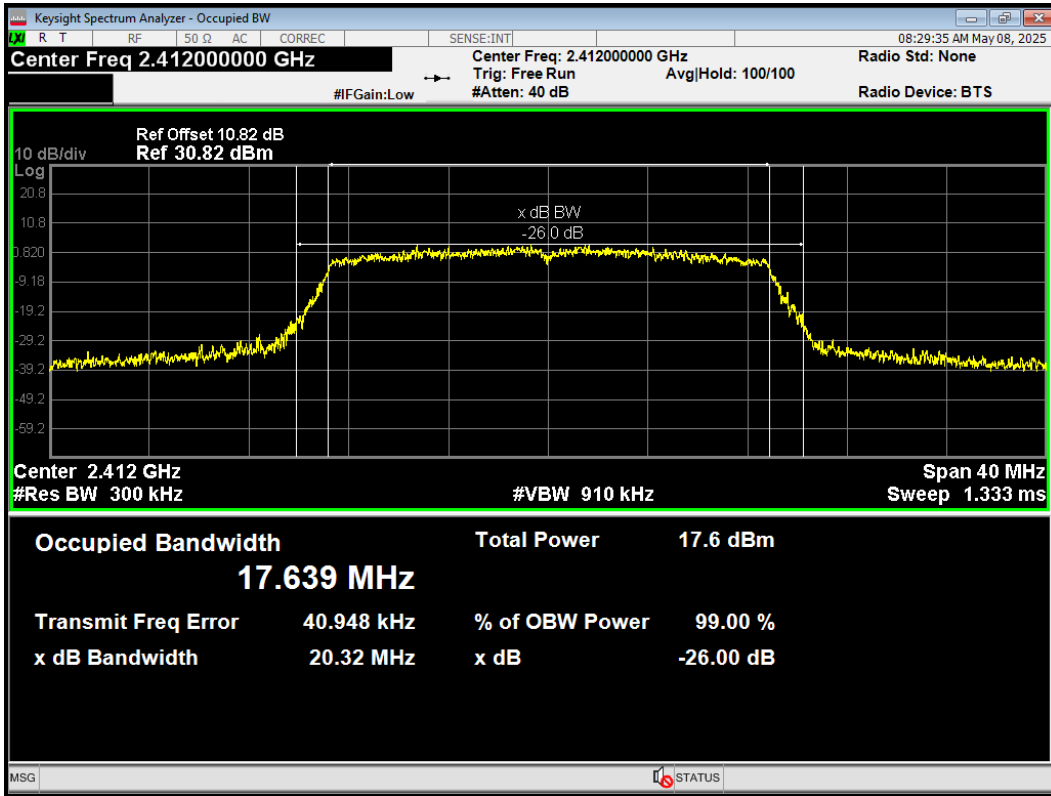

OBW 802.11n(HT20) 2437MHz

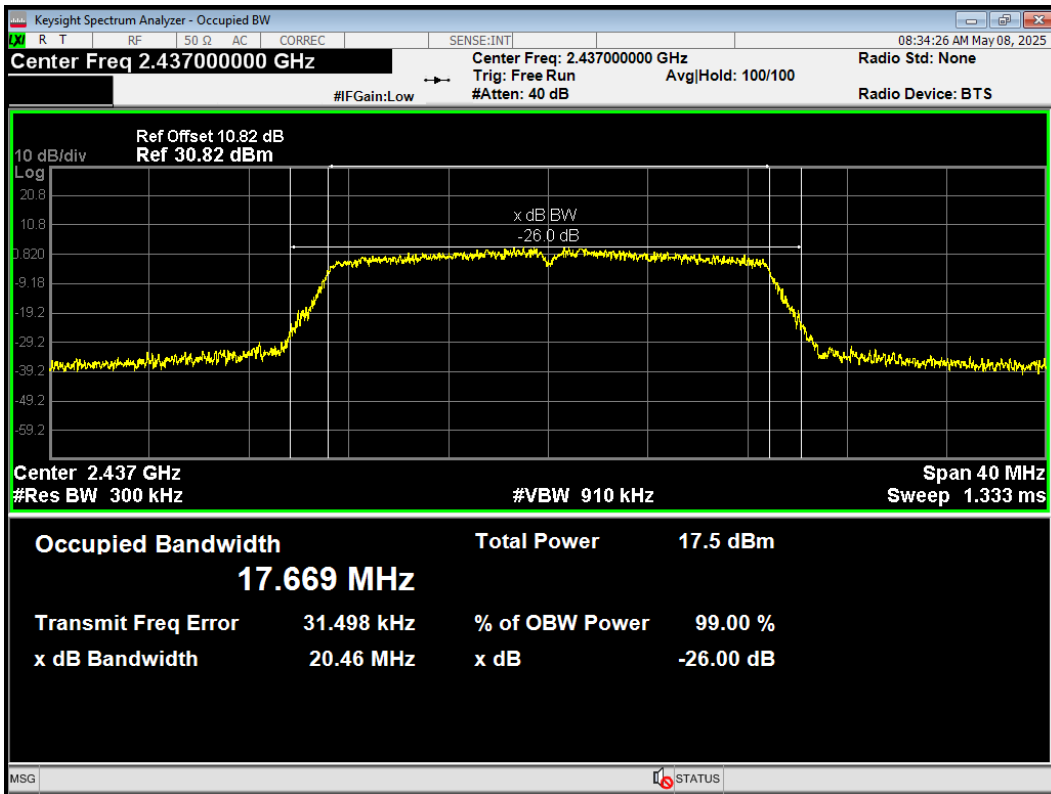

OBW 802.11n(HT20) 2462MHz

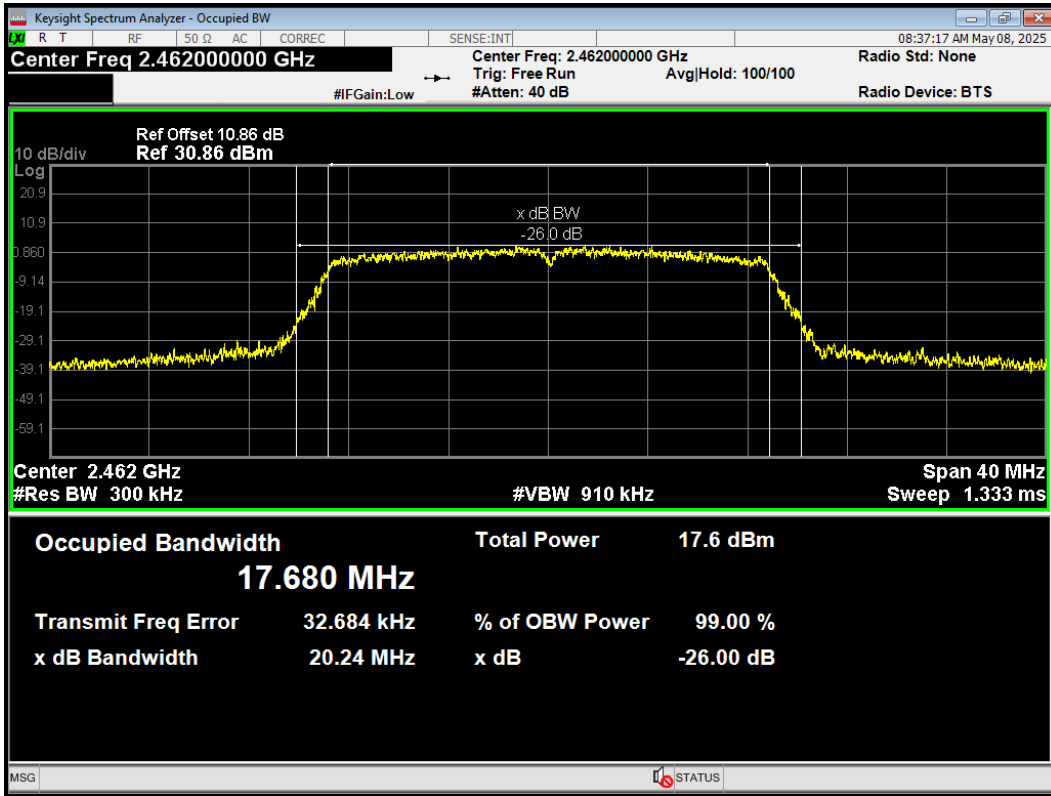

OBW 802.11n(HT40) 2422MHz

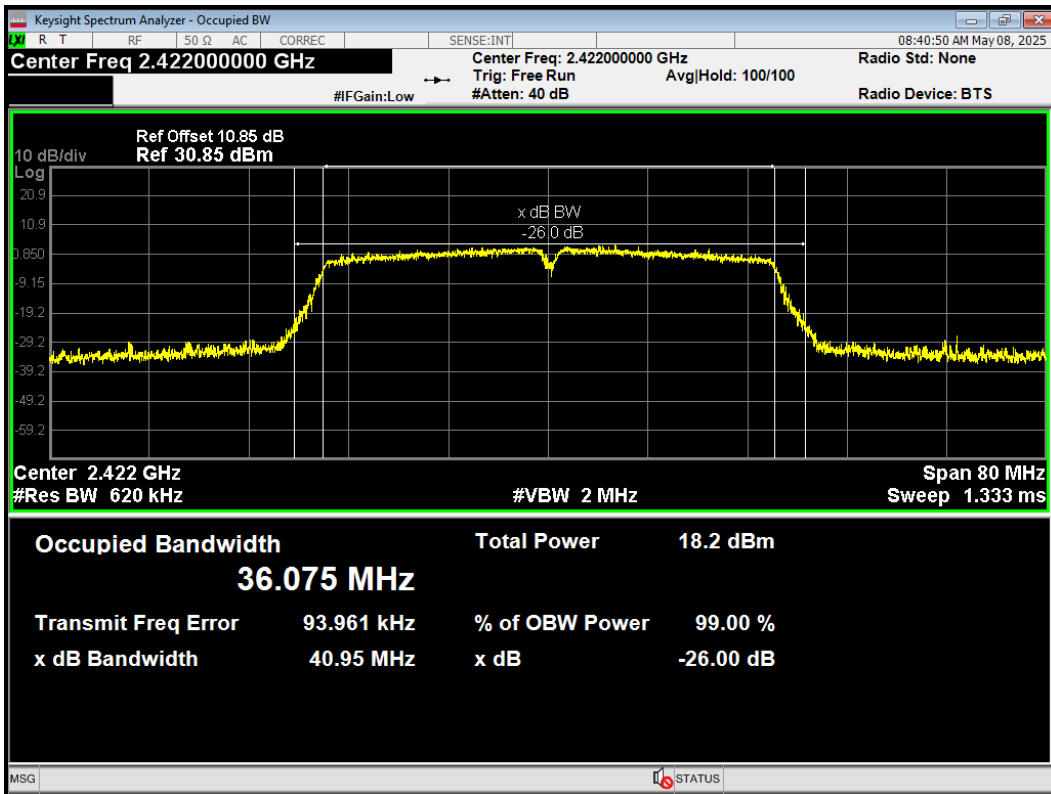

OBW 802.11n(HT40) 2437MHz

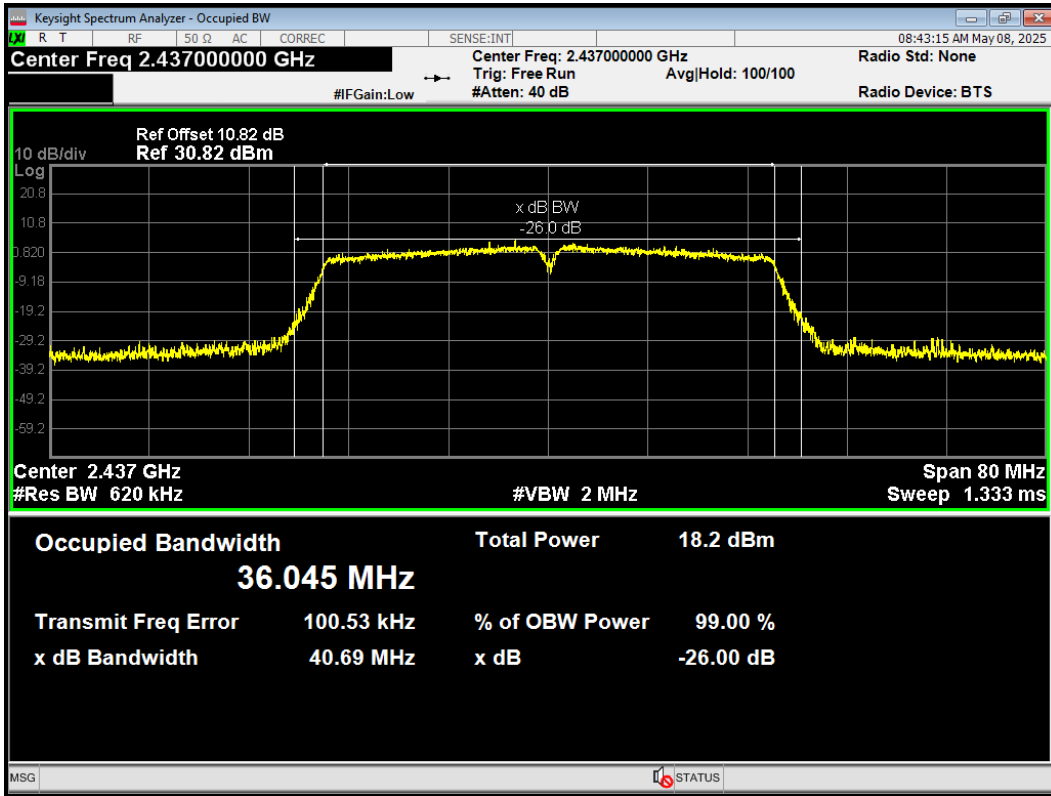

OBW 802.11n(HT40) 2452MHz

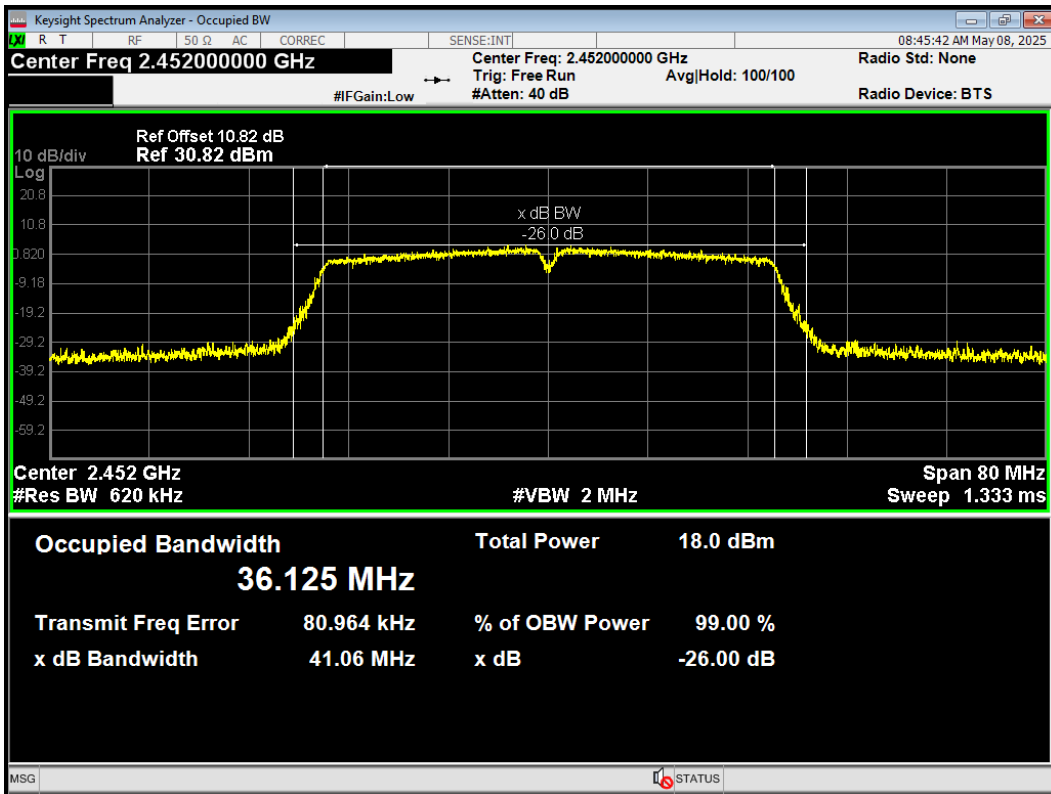

OBW BLE (1M) 2402MHz

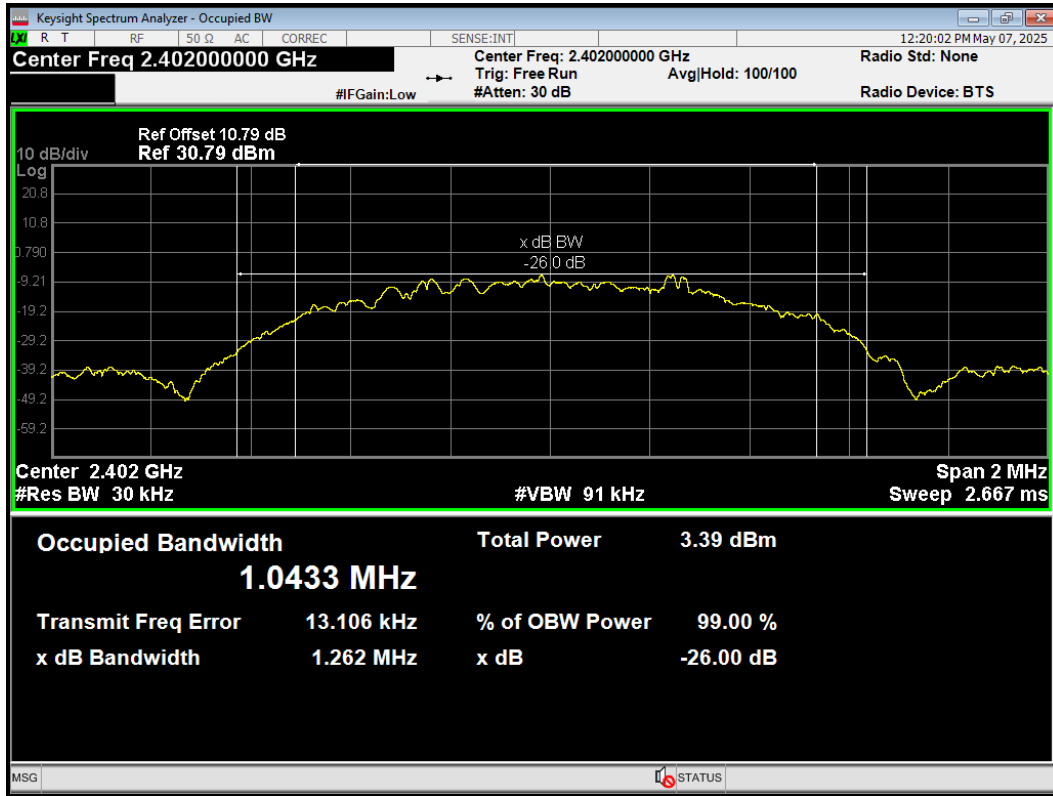

OBW BLE (1M) 2440MHz

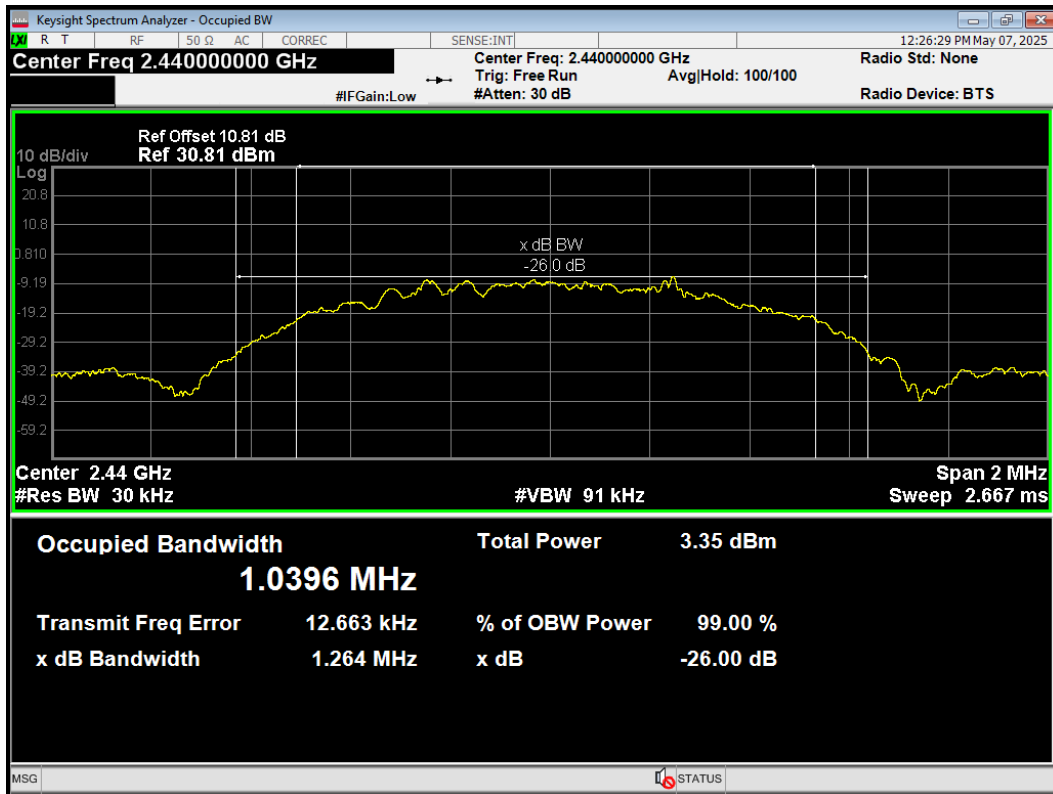

OBW BLE (1M) 2480MHz

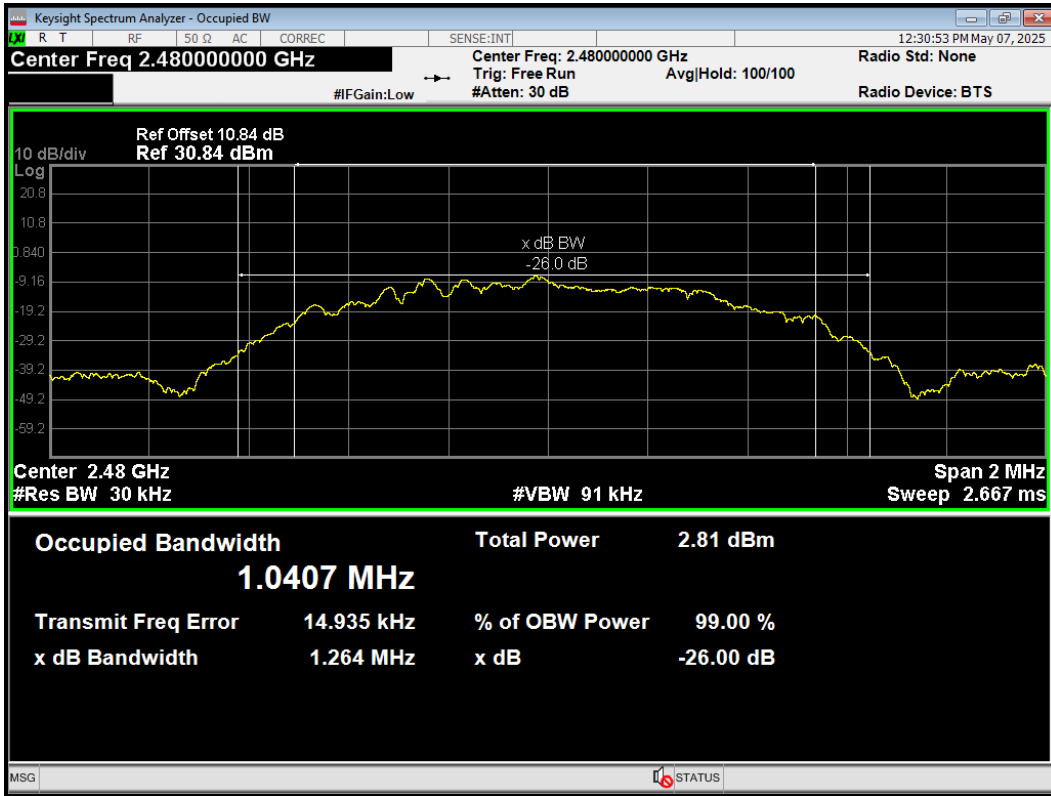

OBW BLE (2M) 2404MHz

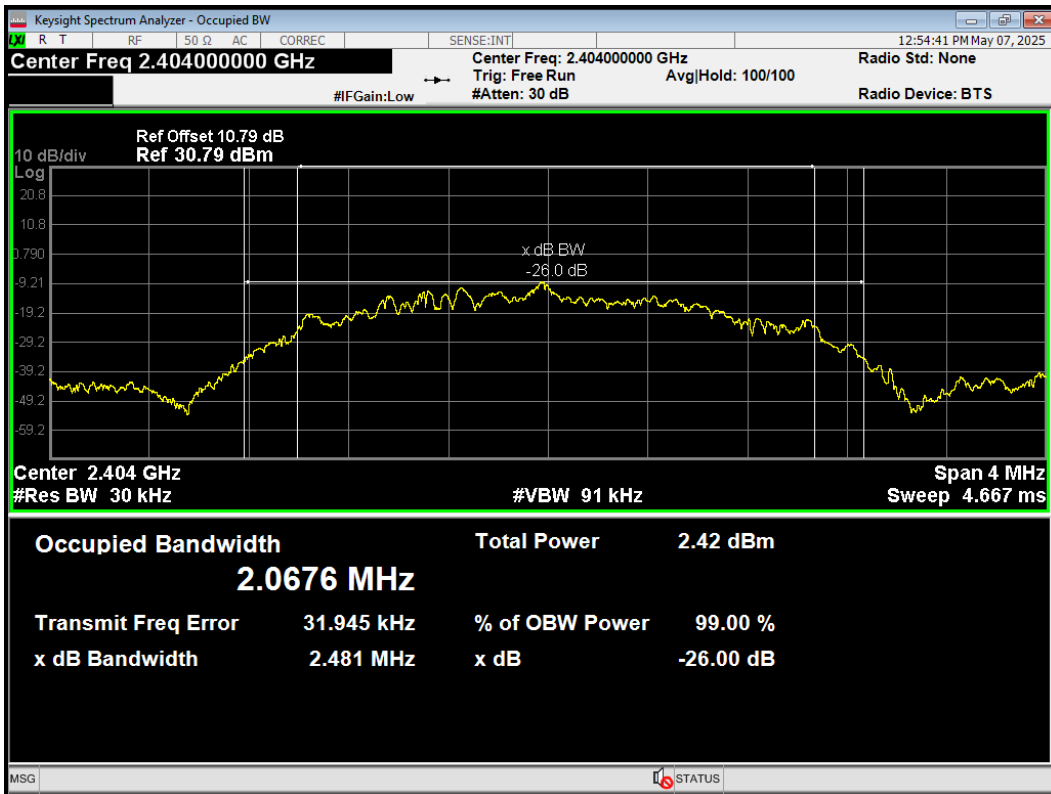

OBW BLE (2M) 2440MHz

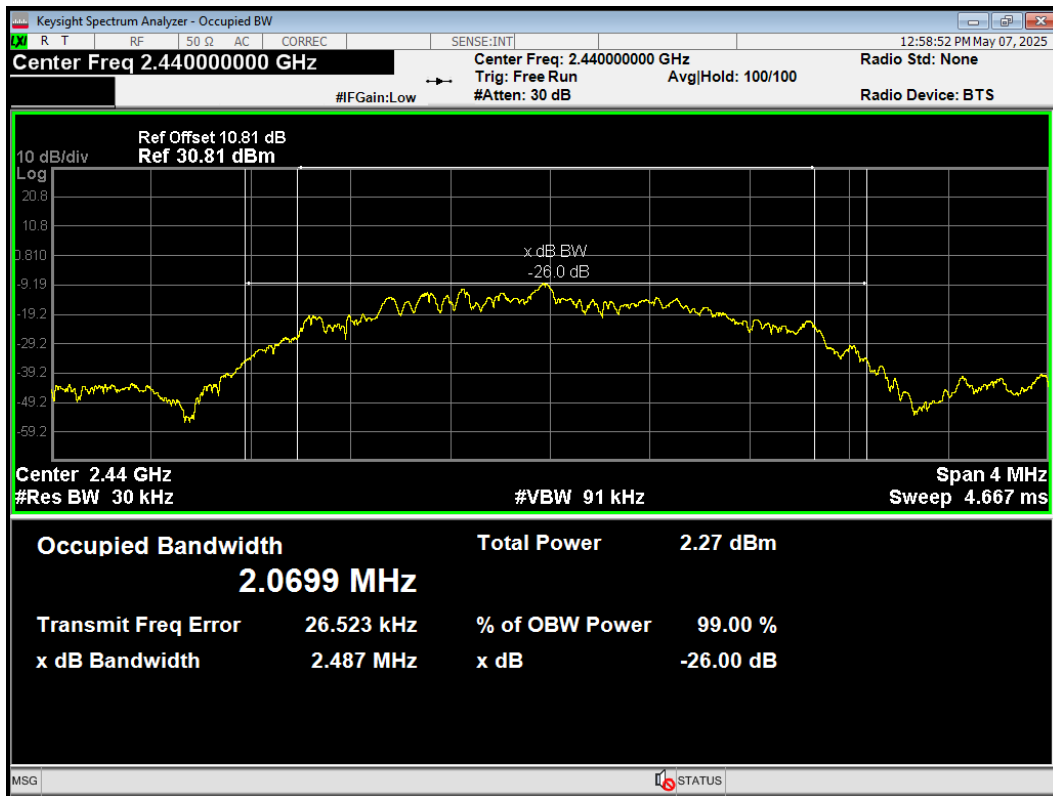

OBW BLE (2M) 2478MHz

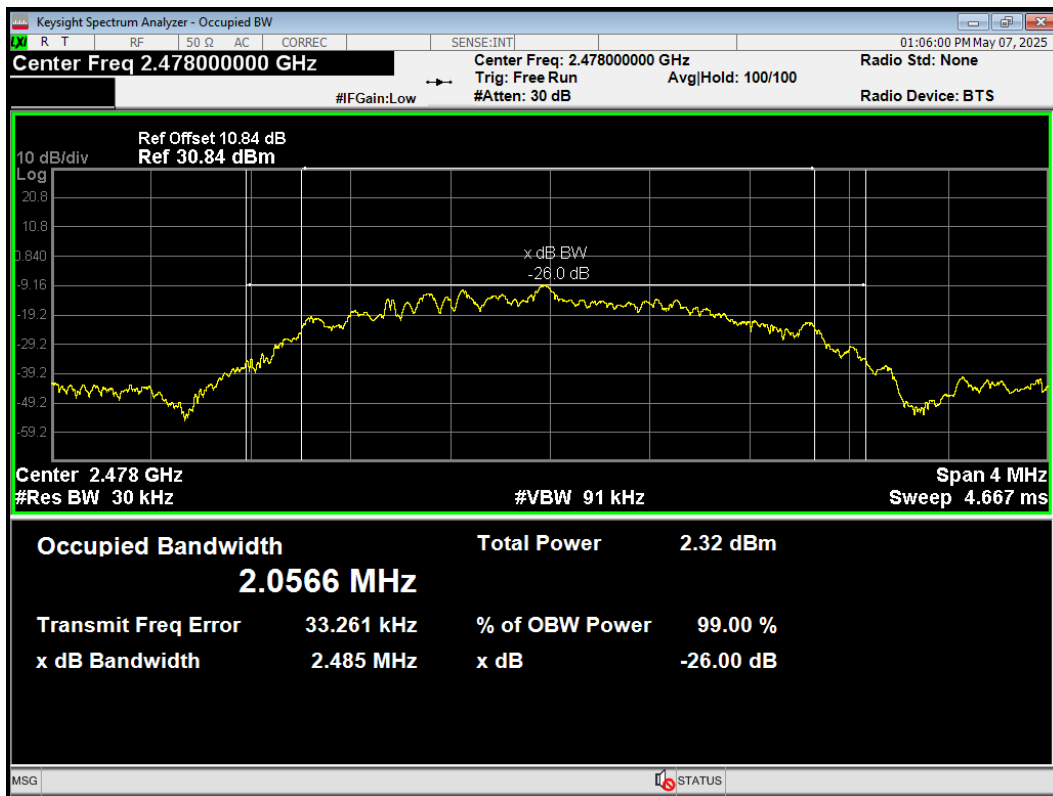

6 dB bandwidth

-6dB Bandwidth 802.11b 2412MHz

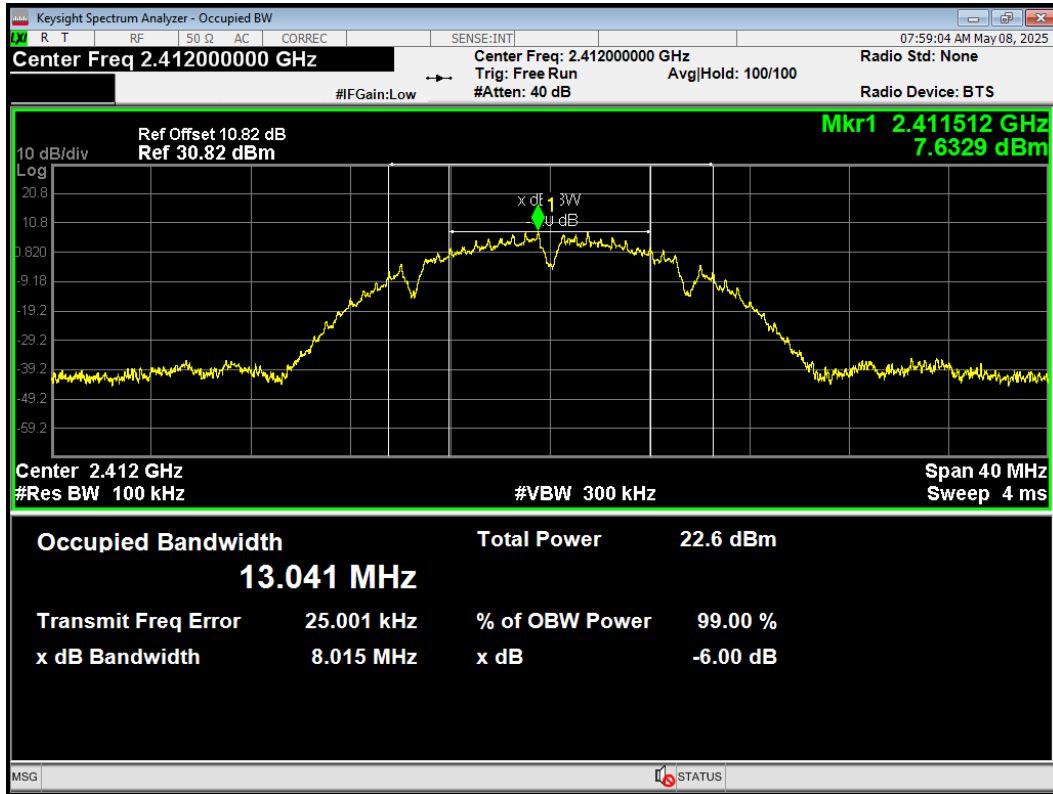

-6dB Bandwidth 802.11b 2437MHz

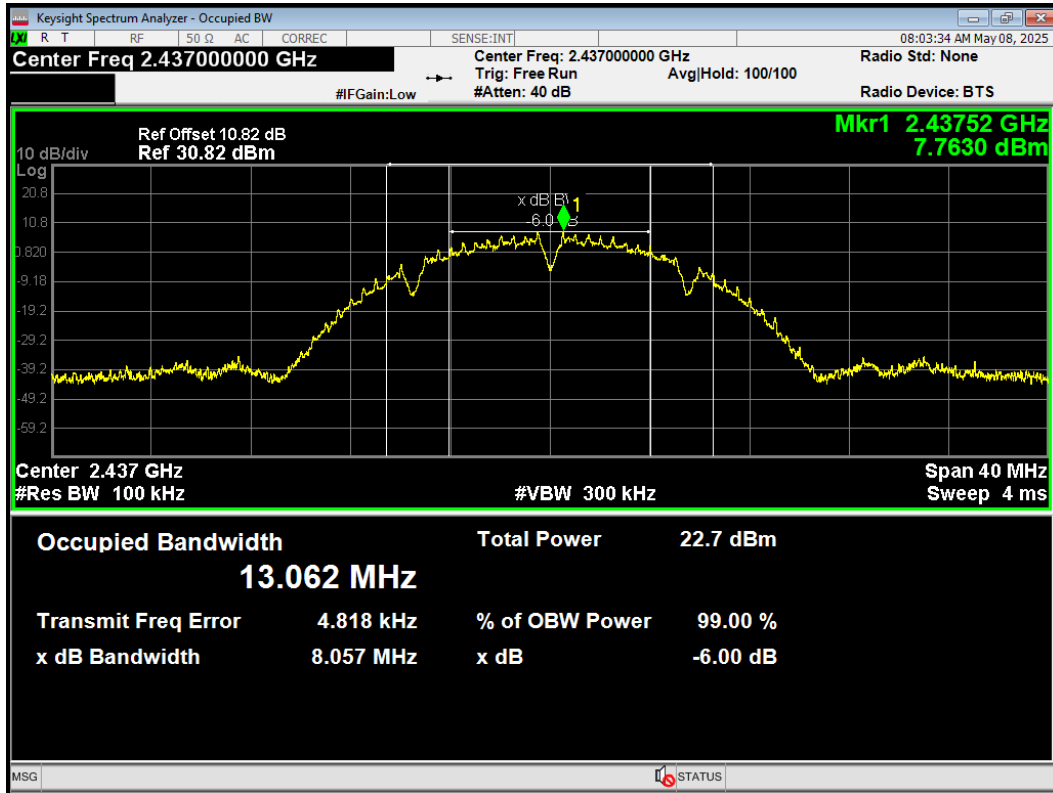

-6dB Bandwidth 802.11b 2462MHz

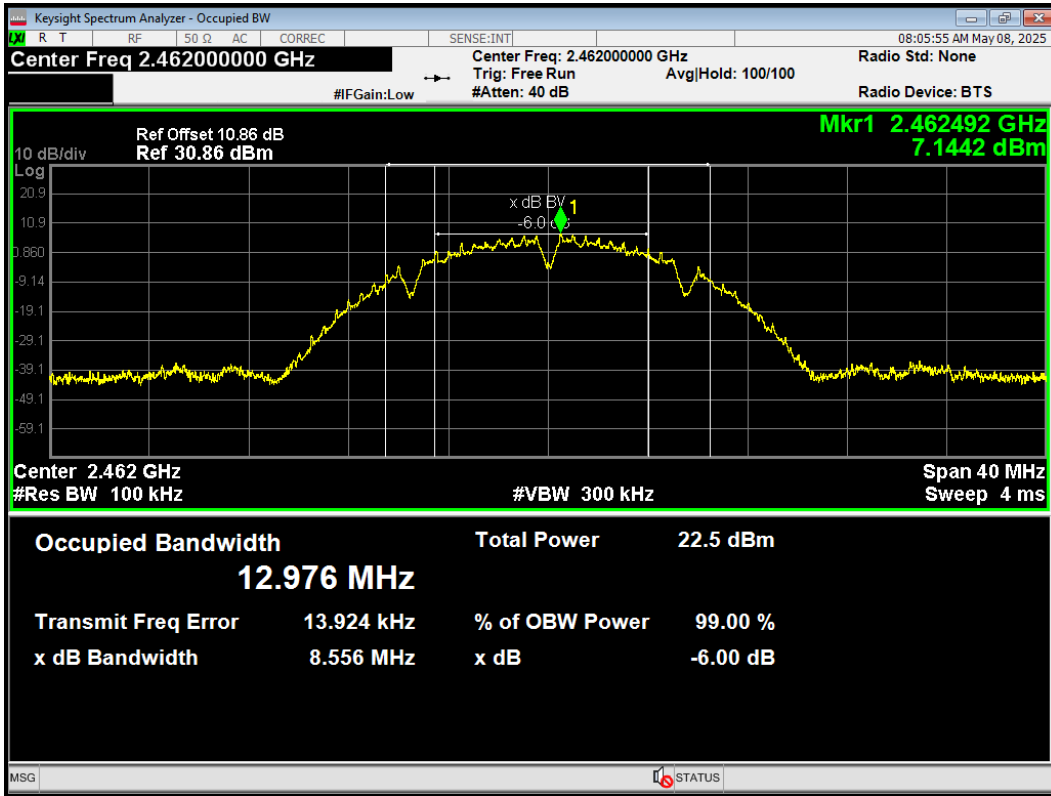

-6dB Bandwidth 802.11g 2412MHz

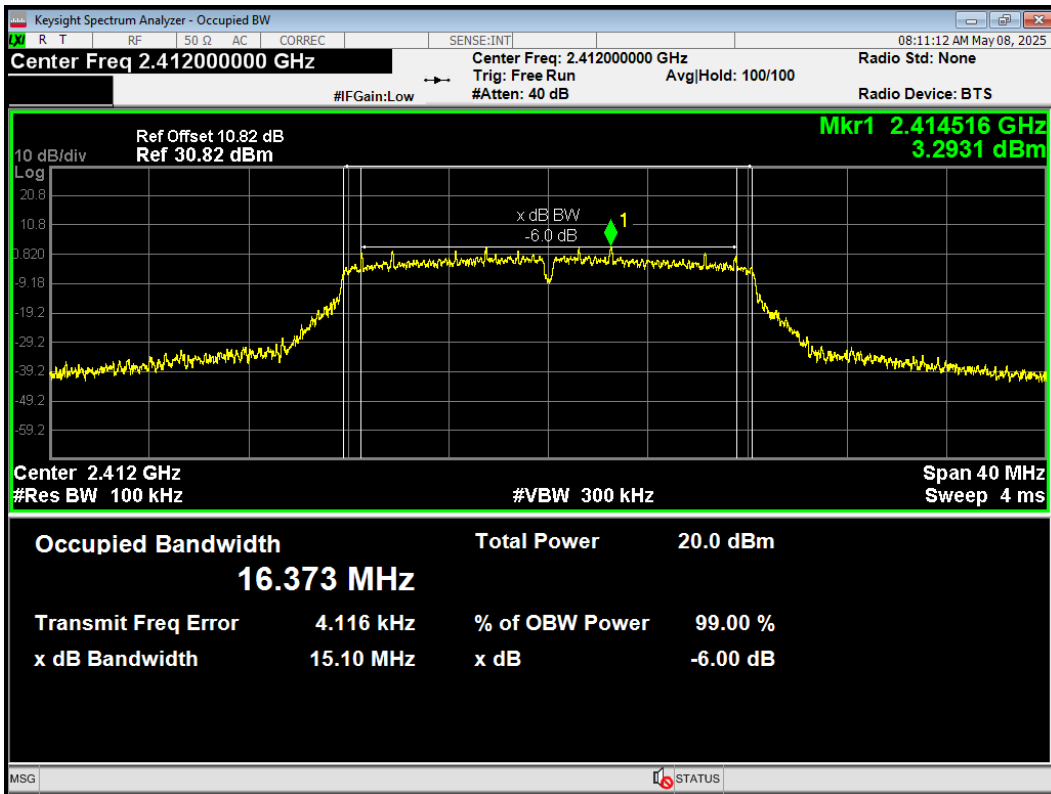

-6dB Bandwidth 802.11g 2437MHz



-6dB Bandwidth 802.11g 2462MHz

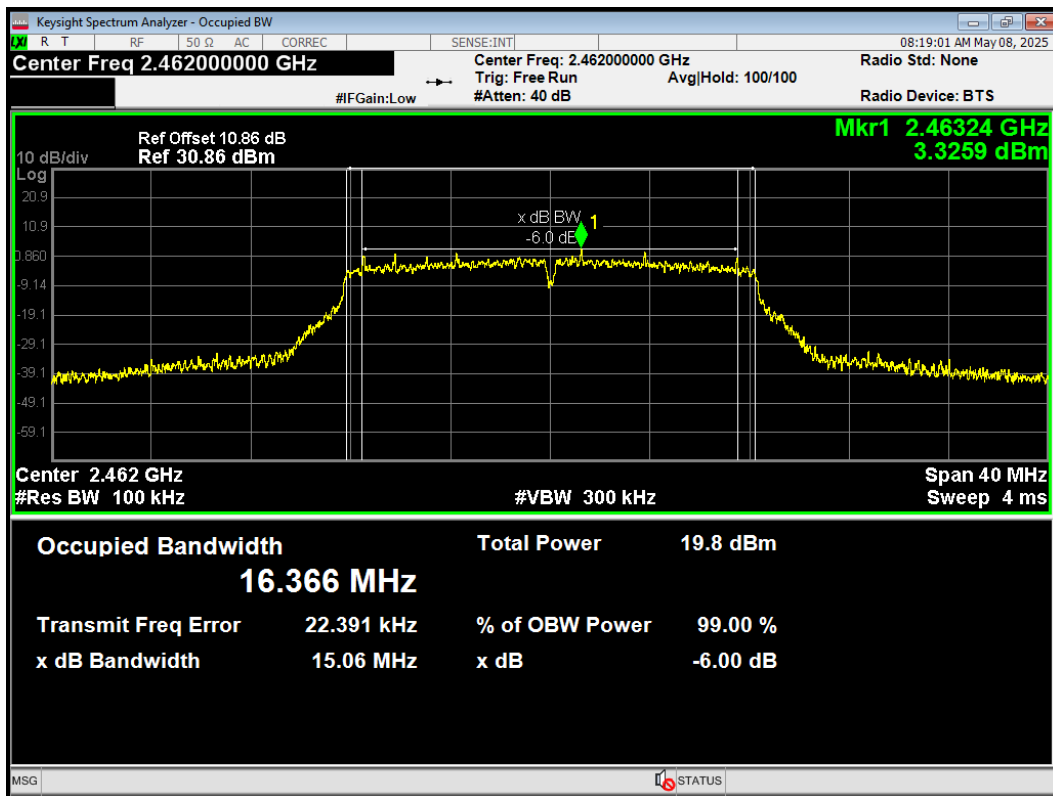

-6dB Bandwidth 802.11n(HT20) 2412MHz

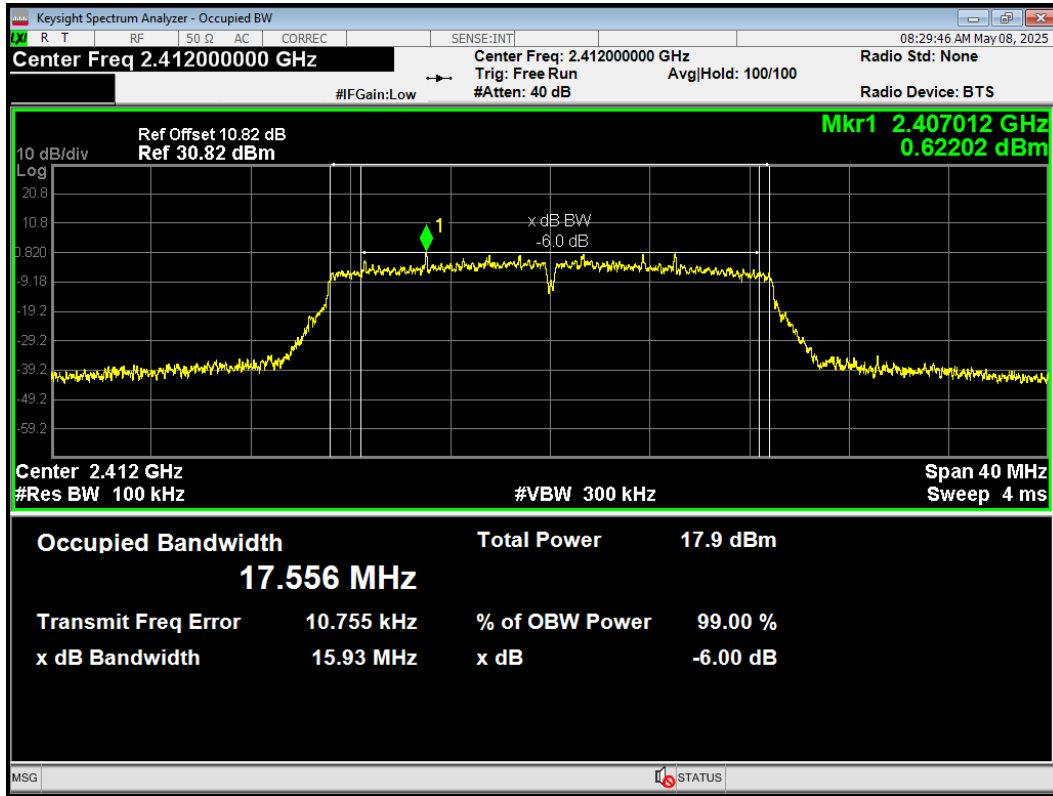

-6dB Bandwidth 802.11n(HT20) 2437MHz

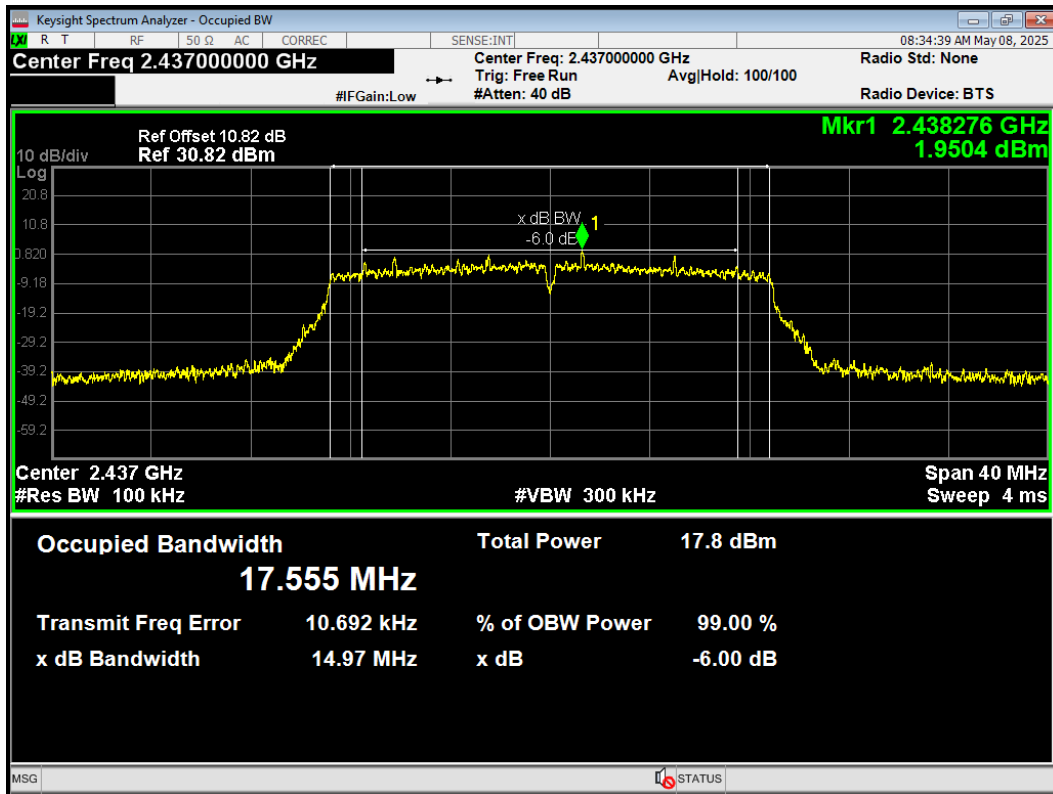

-6dB Bandwidth 802.11n(HT20) 2462MHz

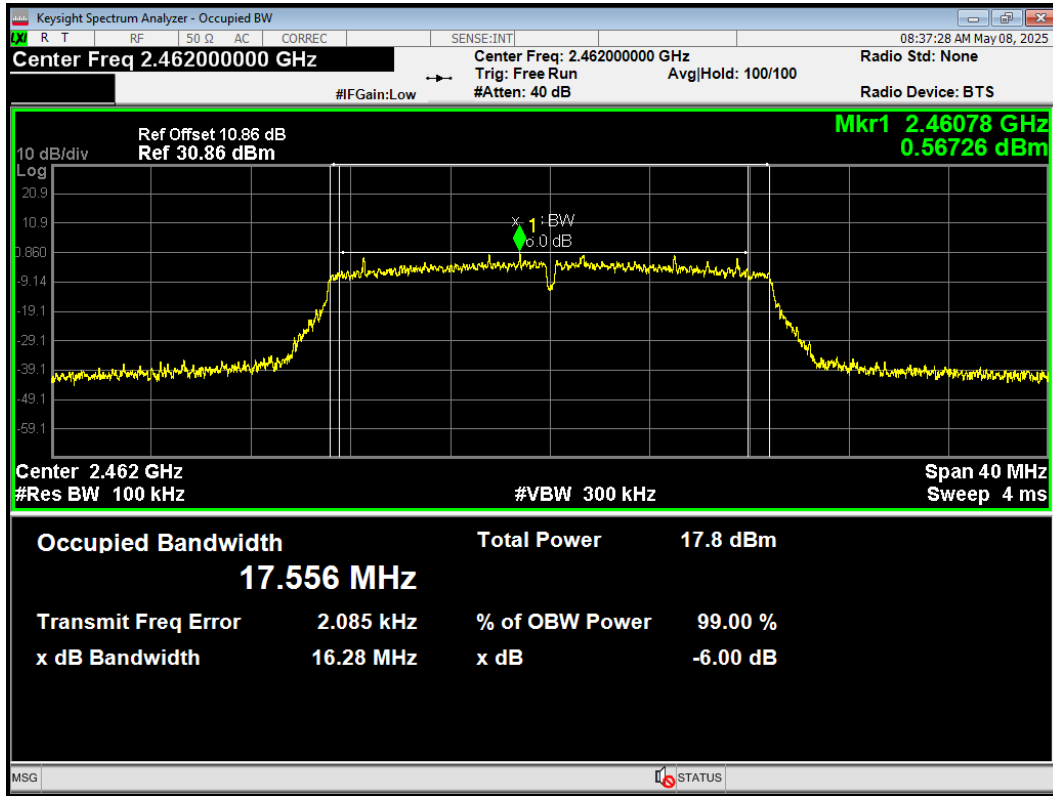

-6dB Bandwidth 802.11n(HT40) 2422MHz

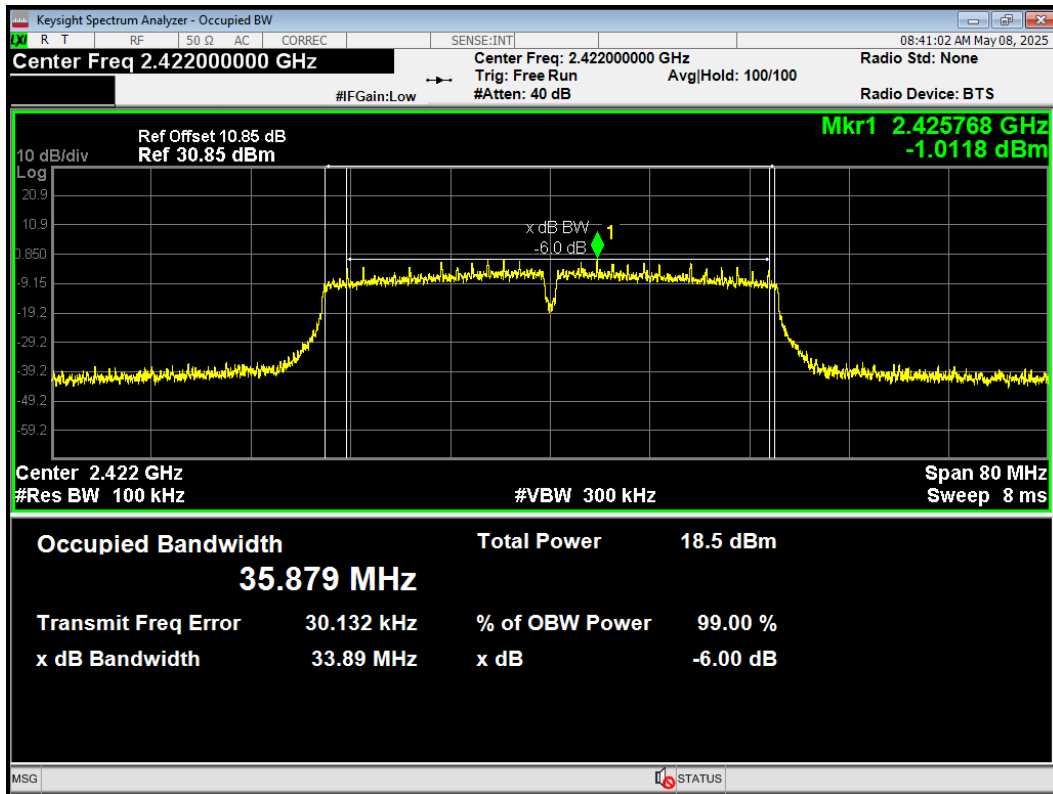

-6dB Bandwidth 802.11n(HT40) 2437MHz

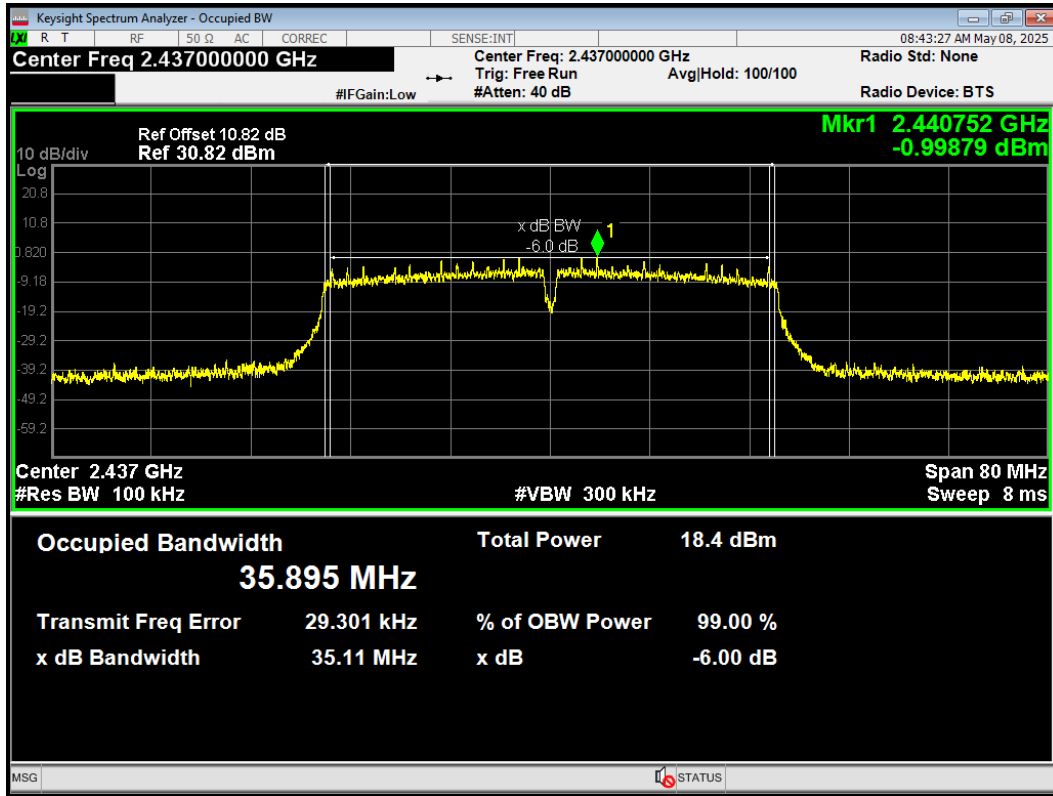

-6dB Bandwidth 802.11n(HT40) 2452MHz

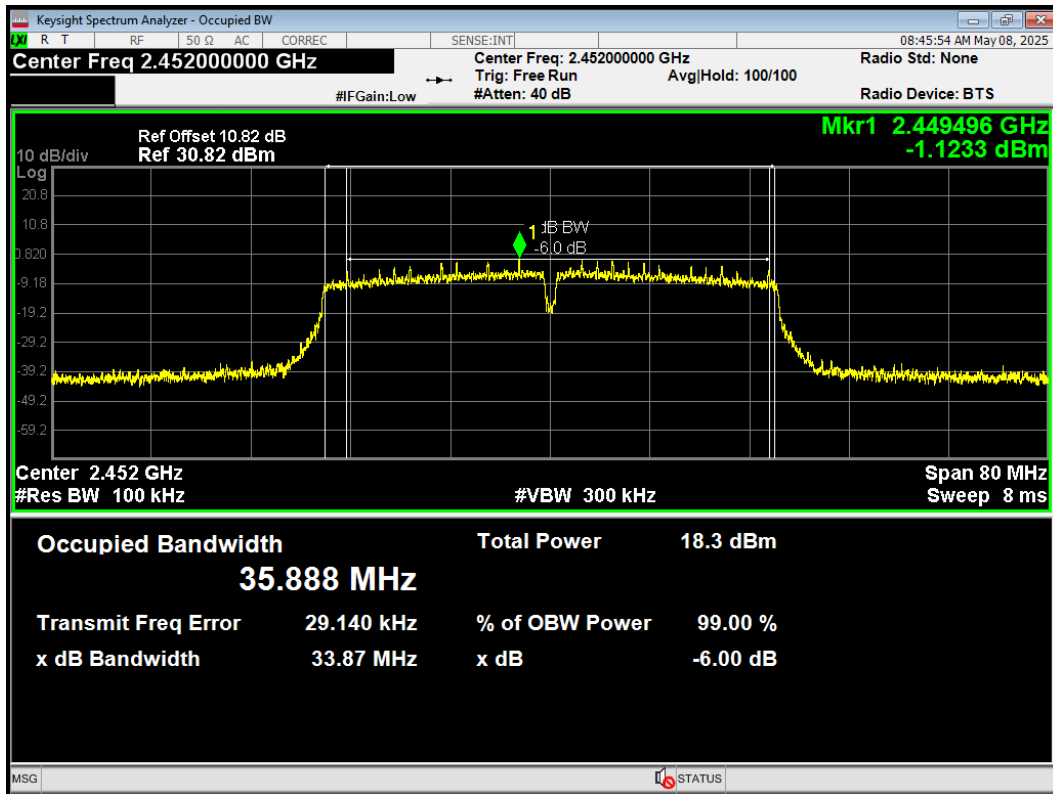

-6dB Bandwidth BLE (1M) 2402MHz

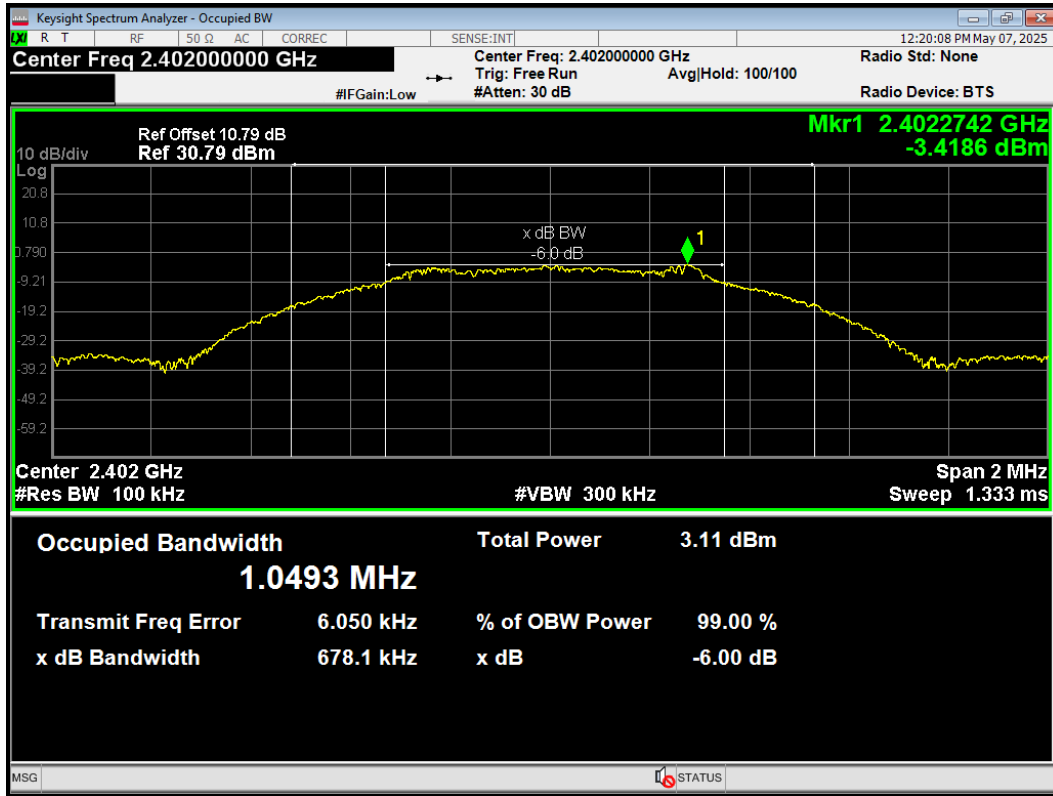

-6dB Bandwidth BLE (1M) 2440MHz

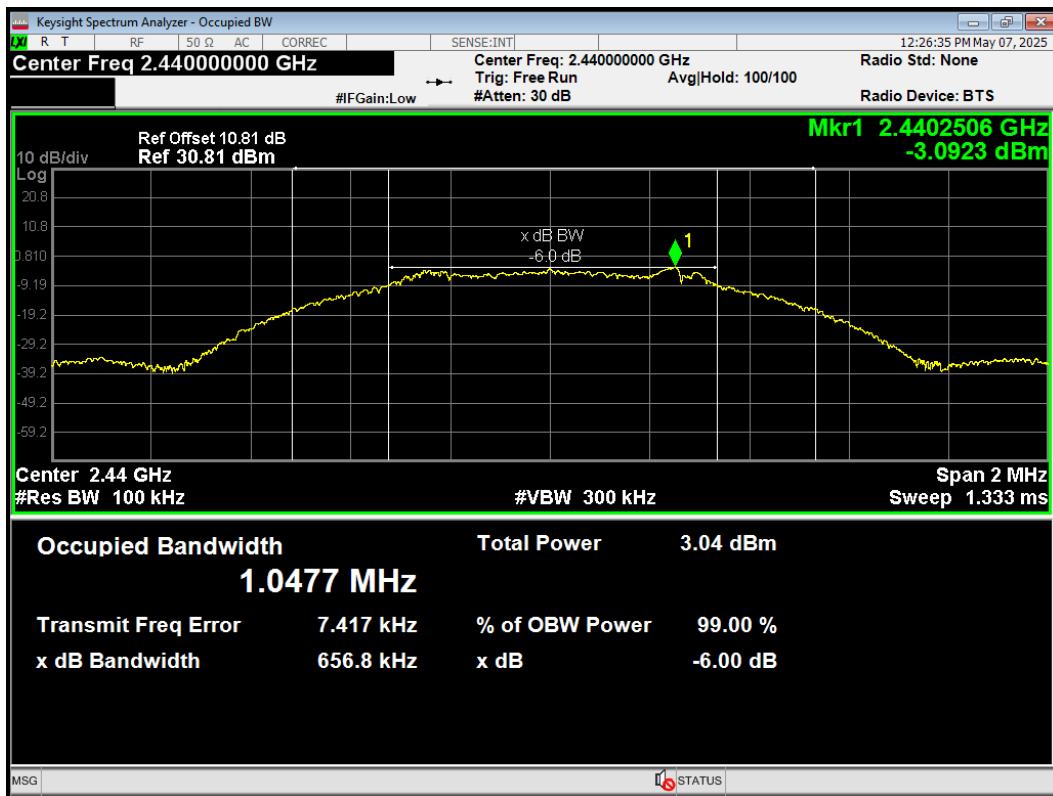

-6dB Bandwidth BLE (1M) 2480MHz

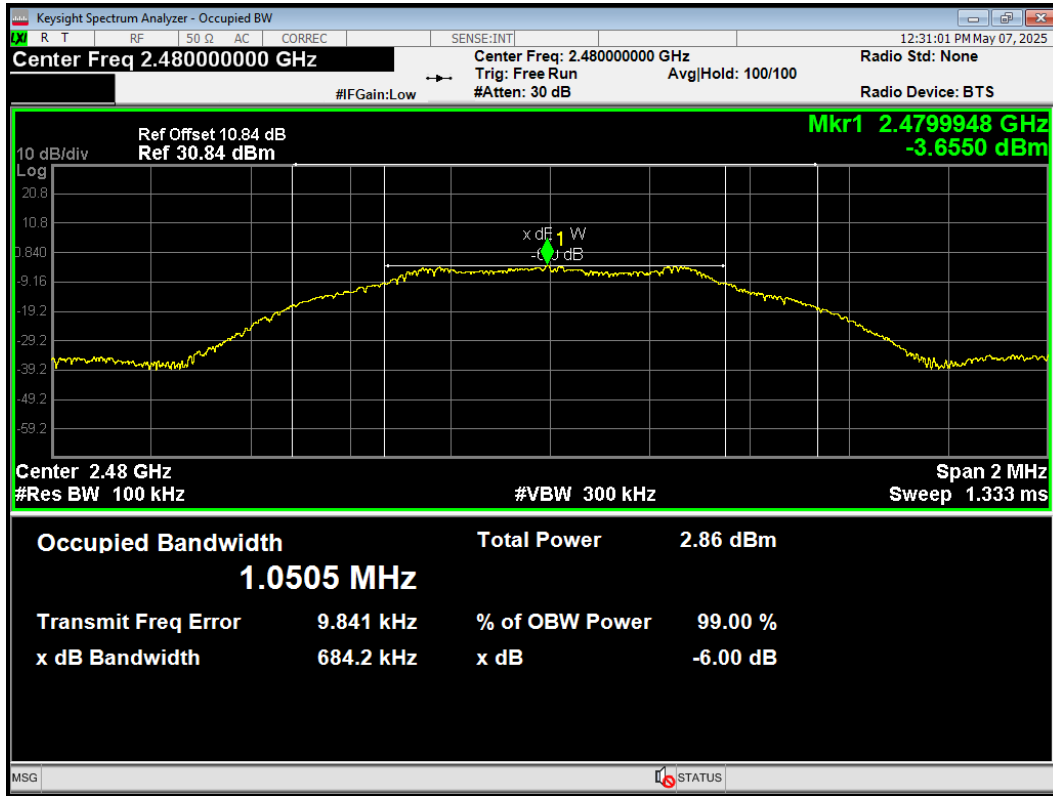

-6dB Bandwidth BLE (2M) 2404MHz

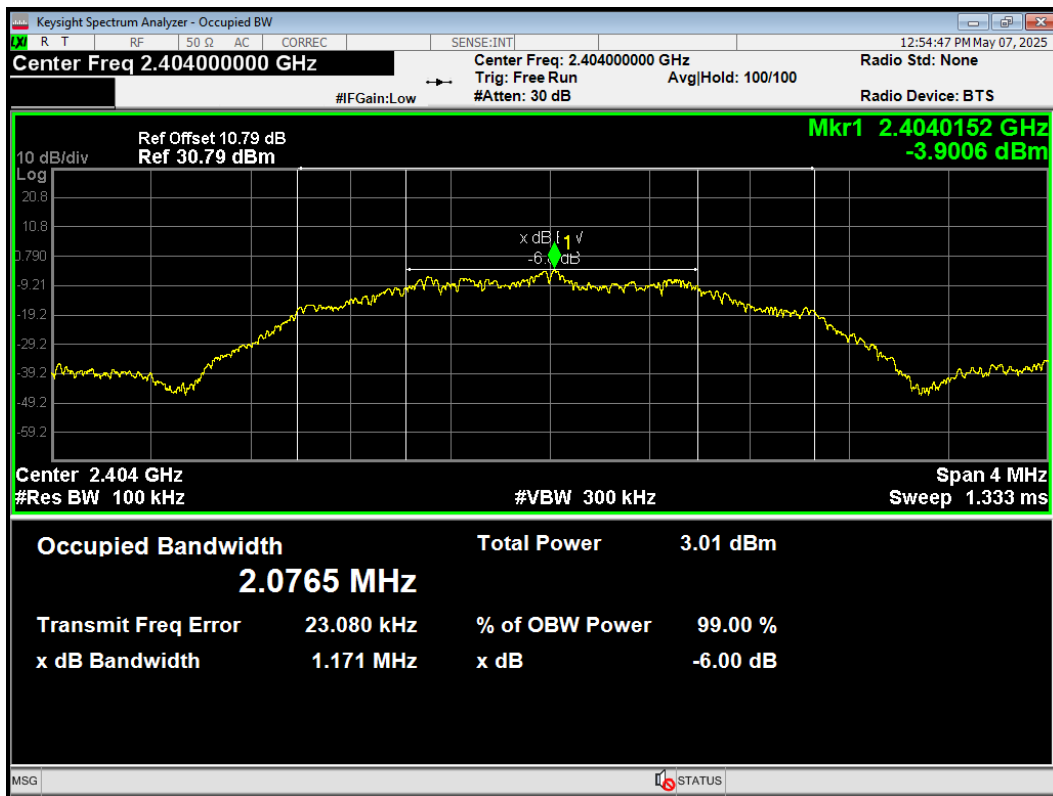

-6dB Bandwidth BLE (2M) 2440MHz

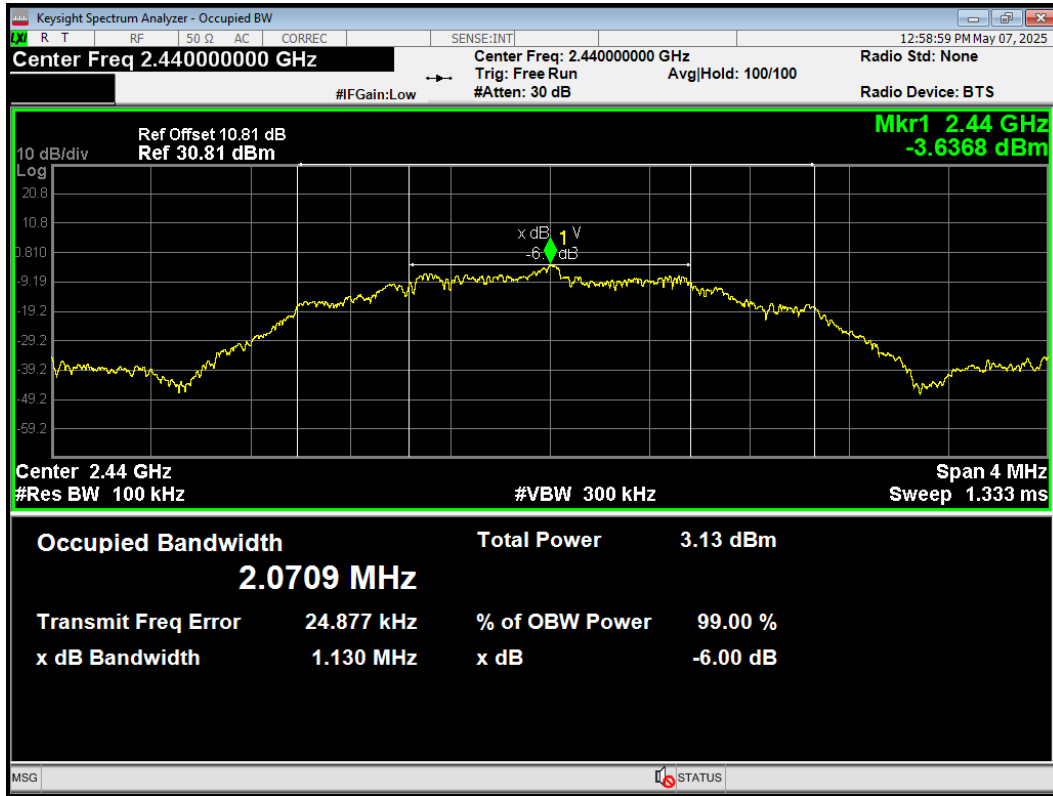

-6dB Bandwidth BLE (2M) 2478MHz

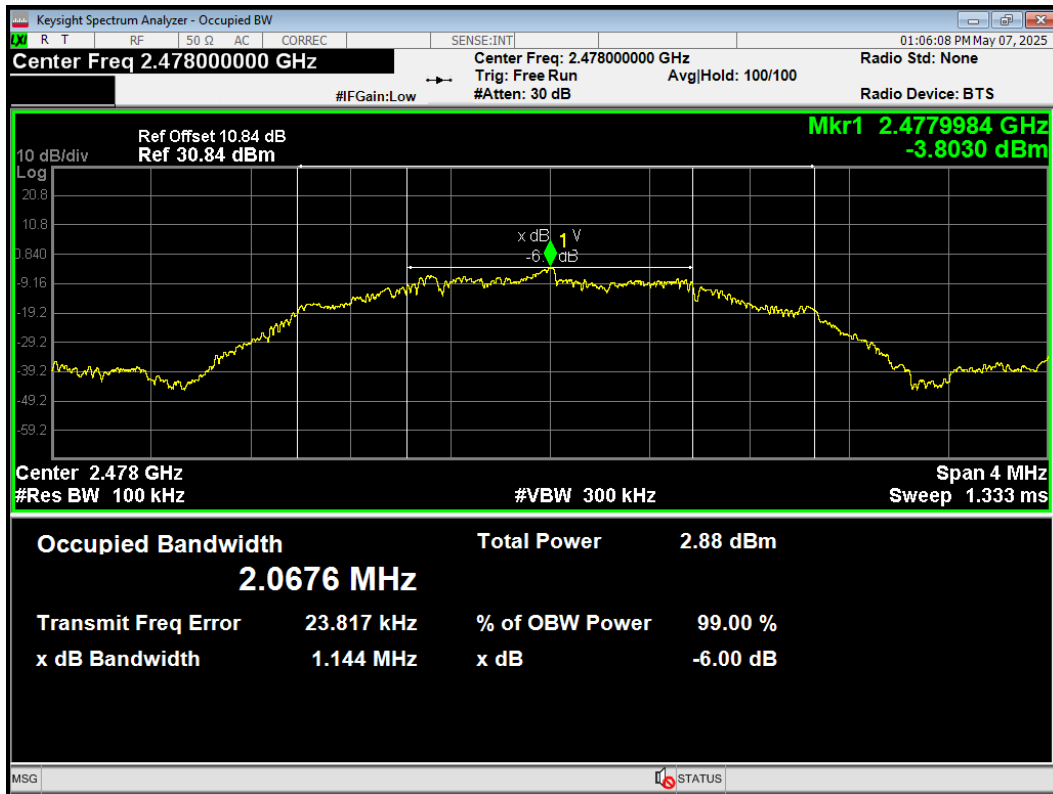

5.3. Band Edge

Ambient Condition

Temperature	Relative humidity
15°C ~ 35°C	20% ~ 80%

Method of Measurement

The EUT was connected to the spectrum analyzer through an external attenuator (20dB) and a known loss cable the band edge of the lowest and highest channels were measured. The peak detector is used and RBW is set to 100 kHz and VBW is set to 300 kHz on spectrum analyzer. Spectrum analyzer plots are included on the following pages.

Test Setup

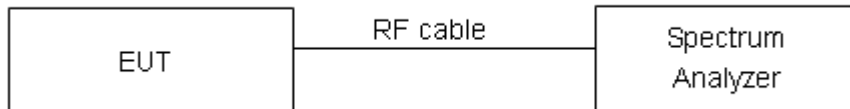

Limits

Rule Part 15.247(d) specifies that “In any 100 kHz bandwidth outside the frequency band in which the spread spectrum or digitally modulated intentional radiator is operating, the radio frequency power that is produced by the intentional radiator shall be at least 20 dB below that in the 100 kHz bandwidth within the band that contains the highest level of the desired power, based on either an RF conducted or a radiated measurement, provided the transmitter demonstrates compliance with the peak conducted power limits.” If the transmitter complies with the conducted power limits based on the use of RMS averaging over a time interval, as permitted under paragraph (b)(3) of this section, the attenuation required under this paragraph shall be 30 dB instead of 20 dB.”

Measurement Uncertainty

The assessed measurement uncertainty to ensure 95% confidence level for the normal distribution is with the coverage factor $k = 1.96$.

Frequency	Uncertainty
2GHz-3GHz	1.407 dB

Test Results: PASS

Band Edge 802.11b 2412MHz Ref

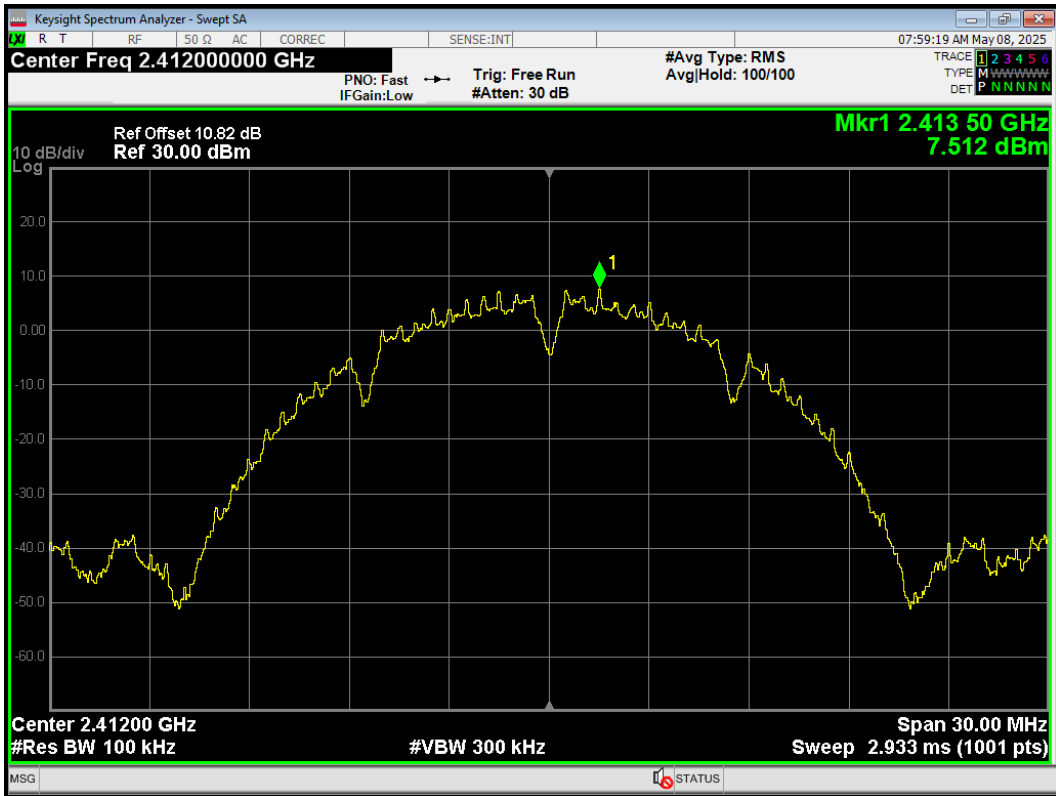

Band Edge 802.11b 2412MHz Emission

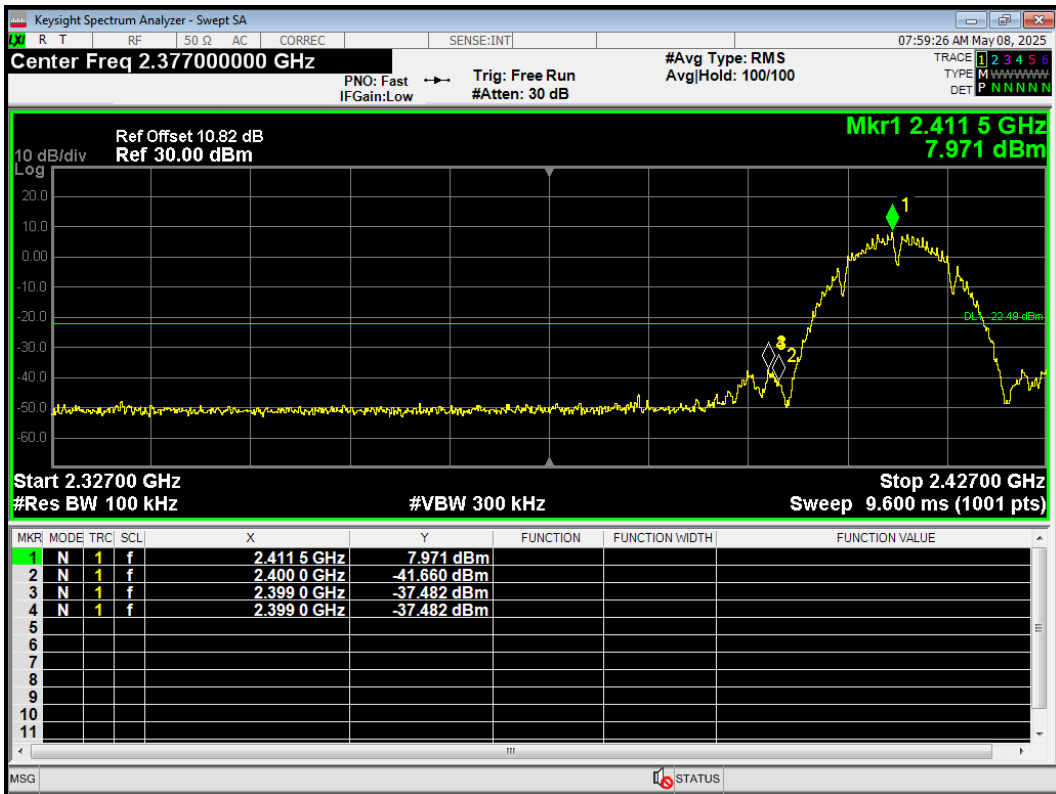

Band Edge 802.11b 2462MHz Ref

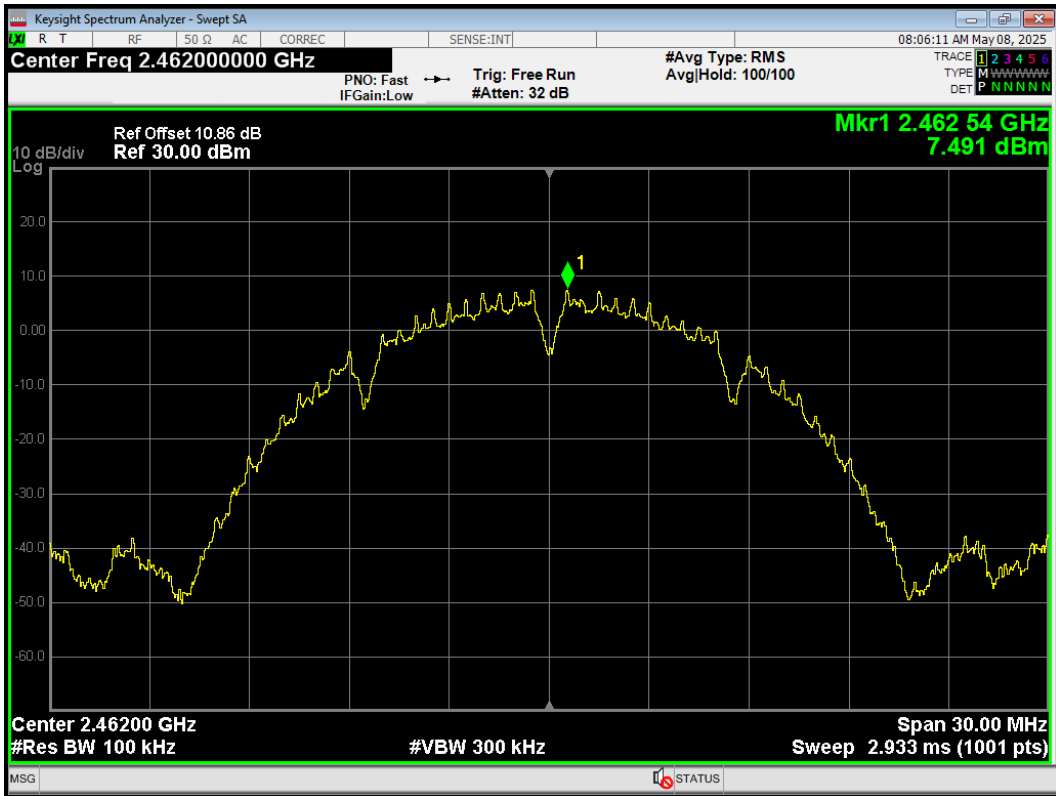

Band Edge 802.11b 2462MHz Emission

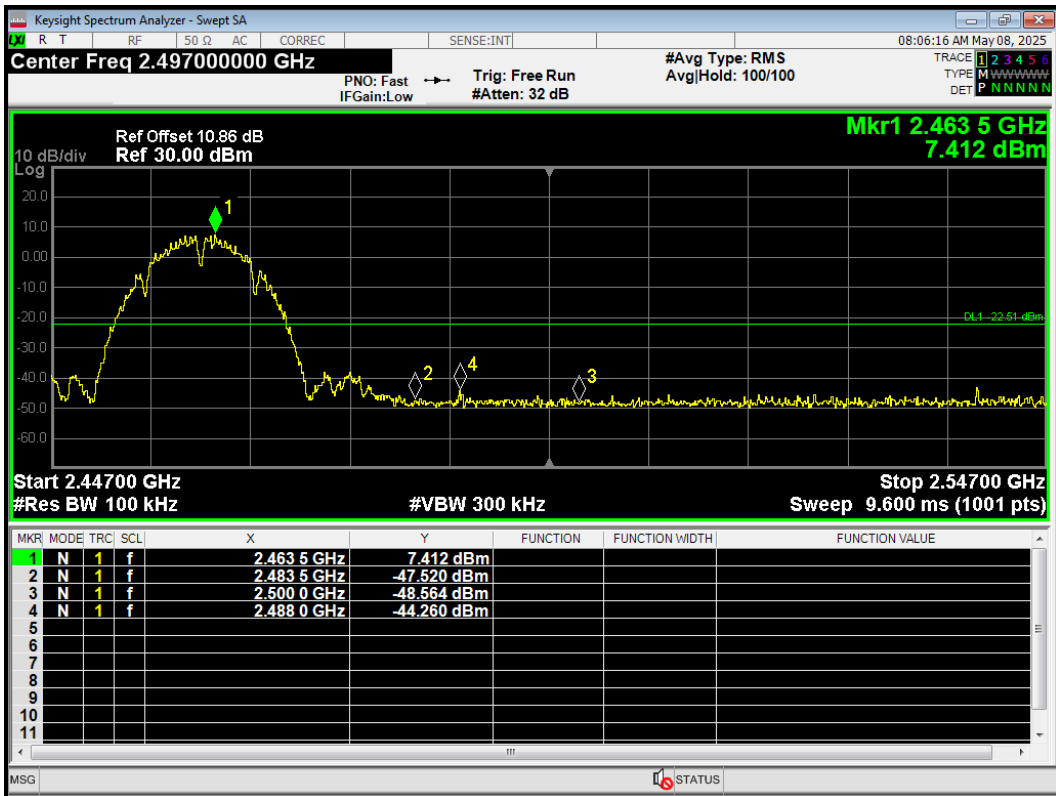

Band Edge 802.11g 2412MHz Ref

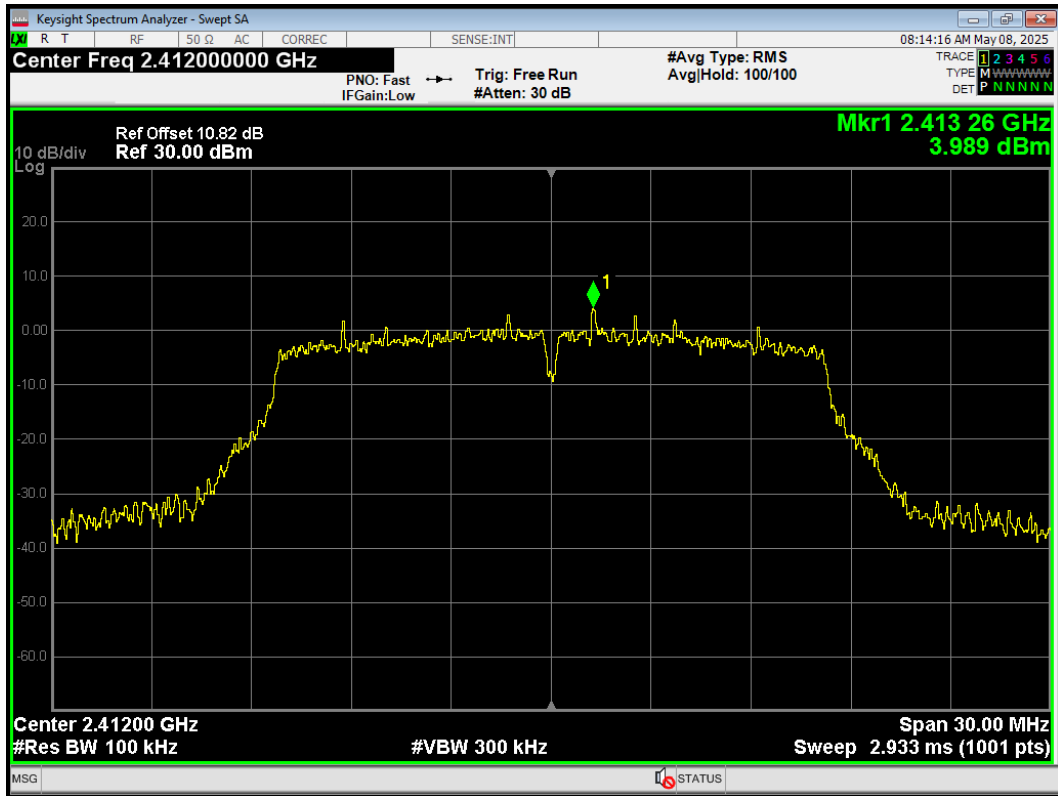

Band Edge 802.11g 2412MHz Emission

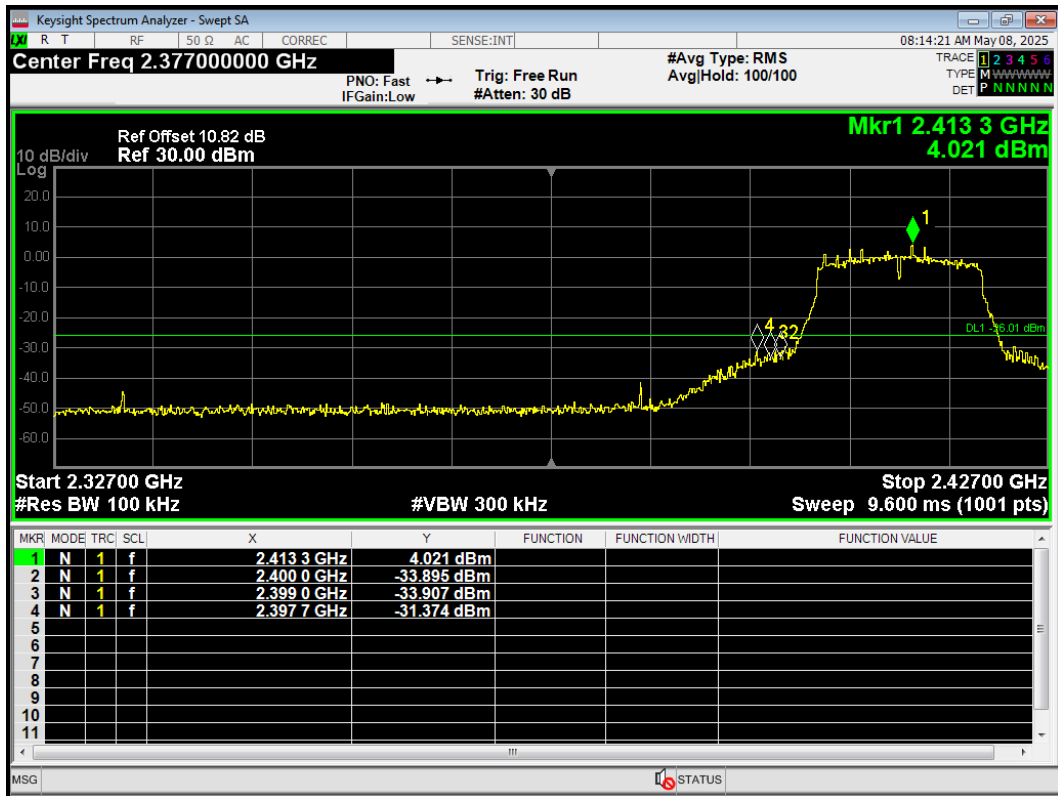

Band Edge 802.11g 2462MHz Ref

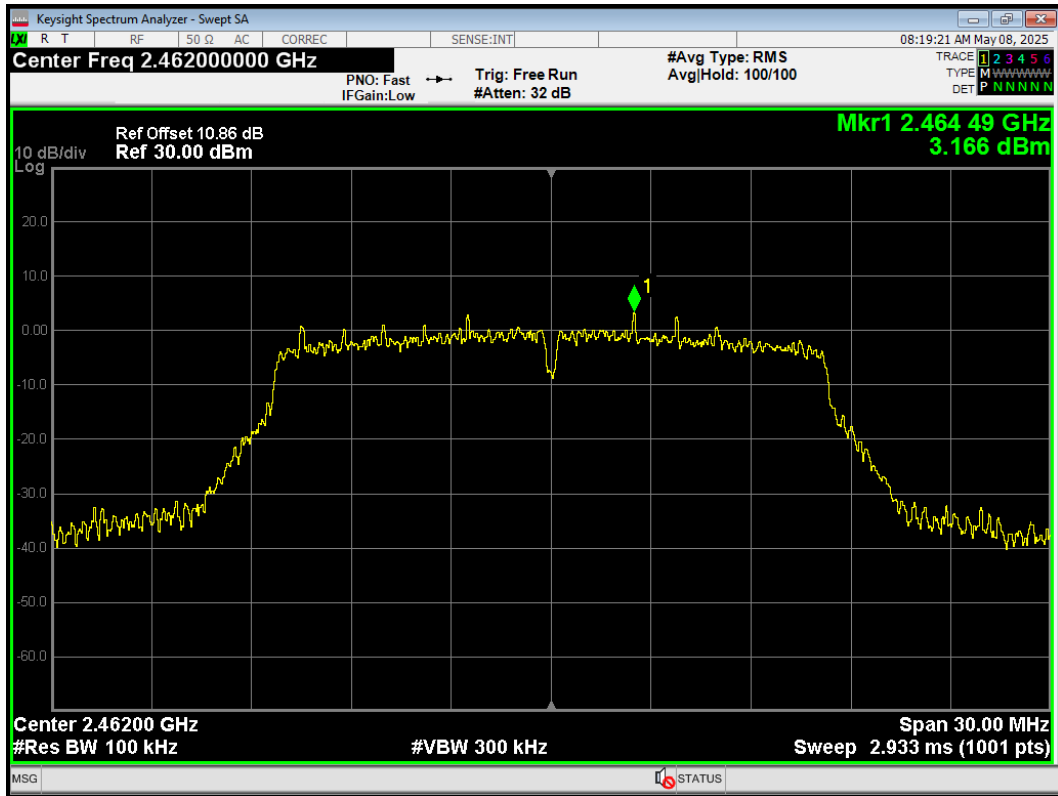

Band Edge 802.11g 2462MHz Emission

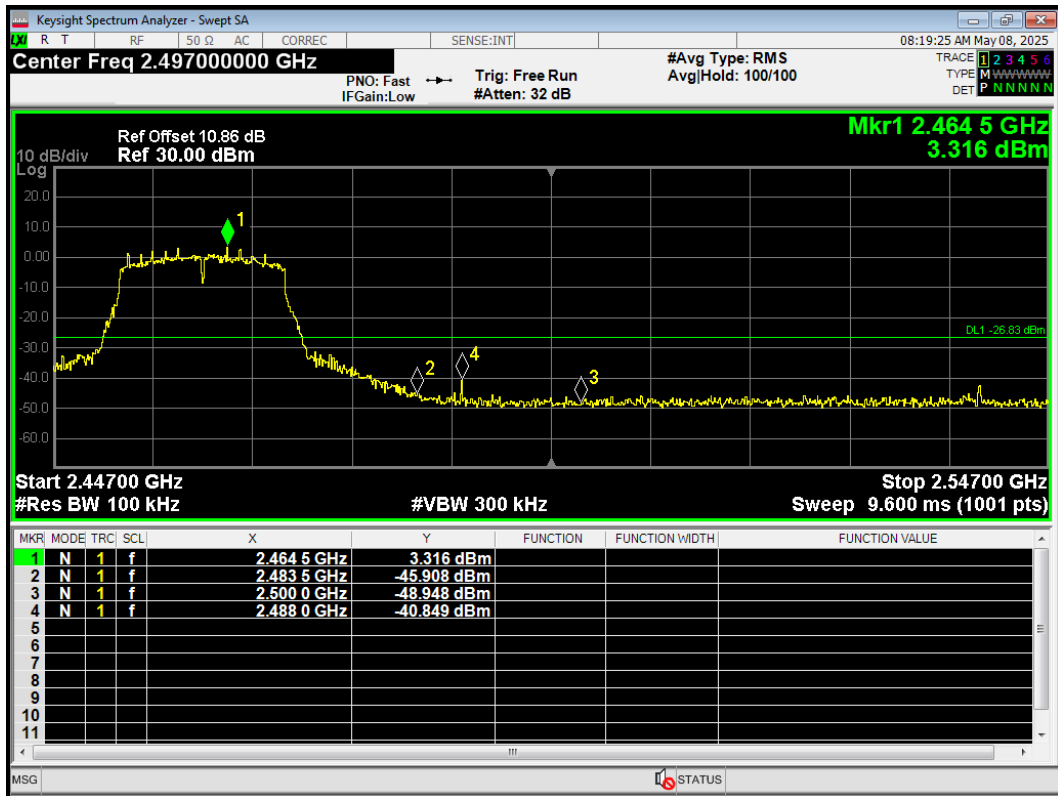

Band Edge 802.11n(HT20) 2412MHz Ref

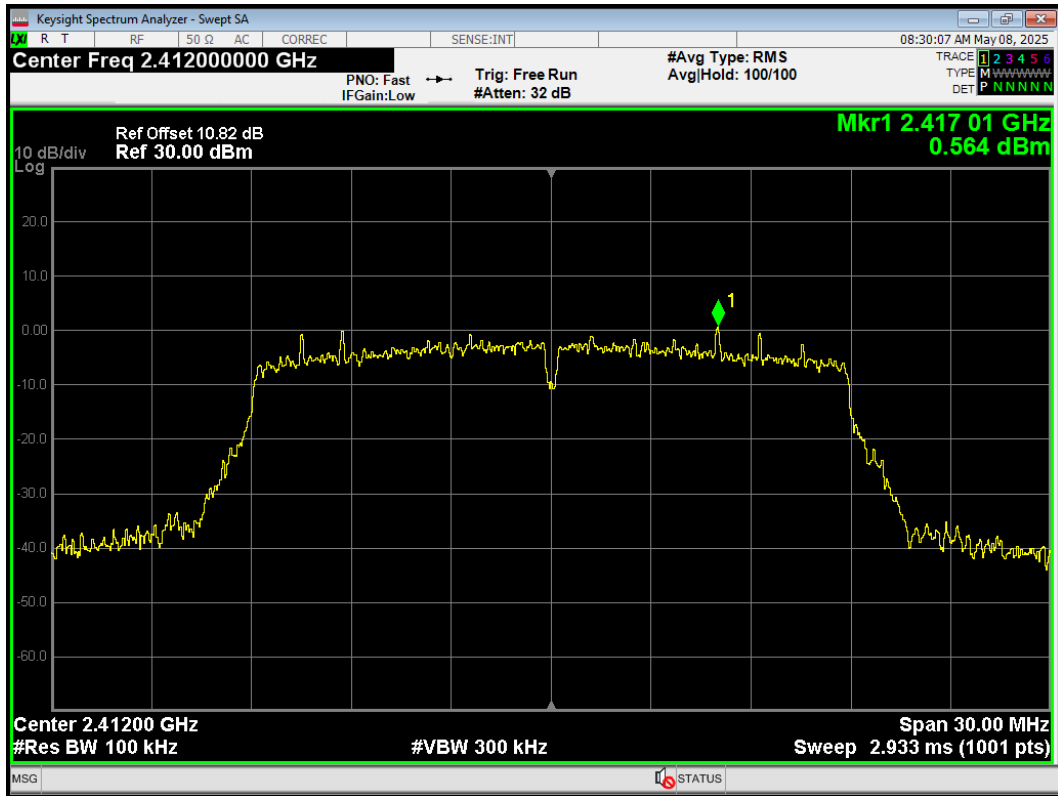

Band Edge 802.11n(HT20) 2412MHz Emission

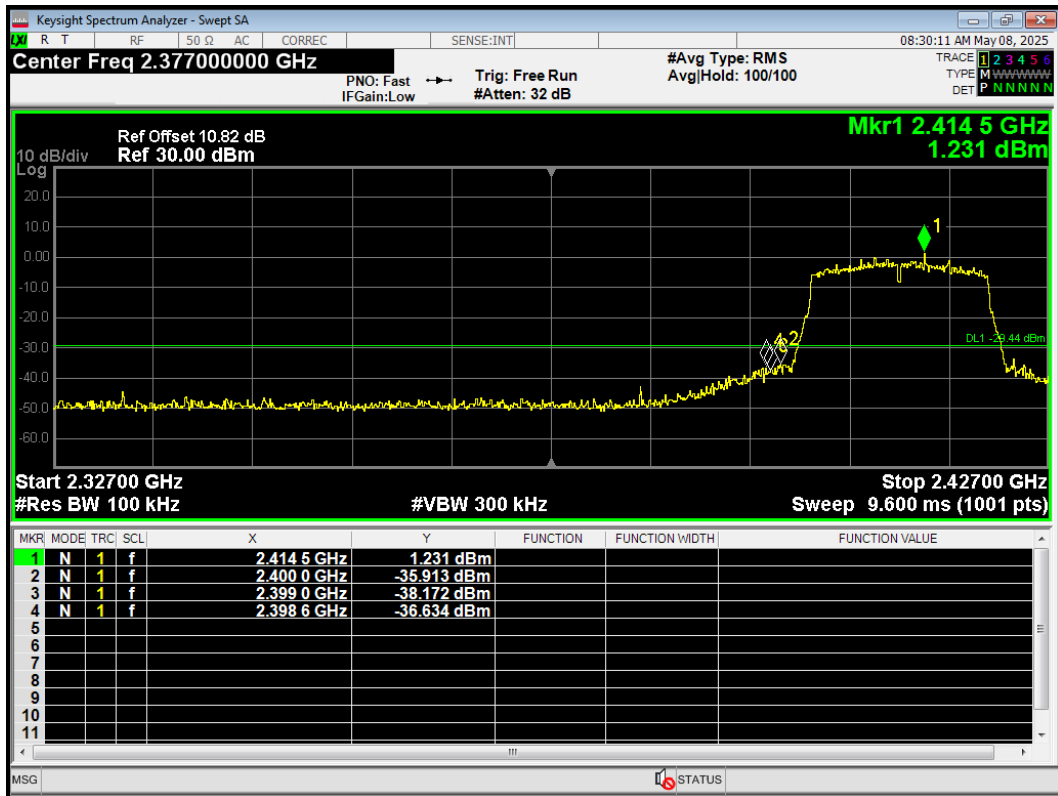

Band Edge 802.11n(HT20) 2462MHz Ref

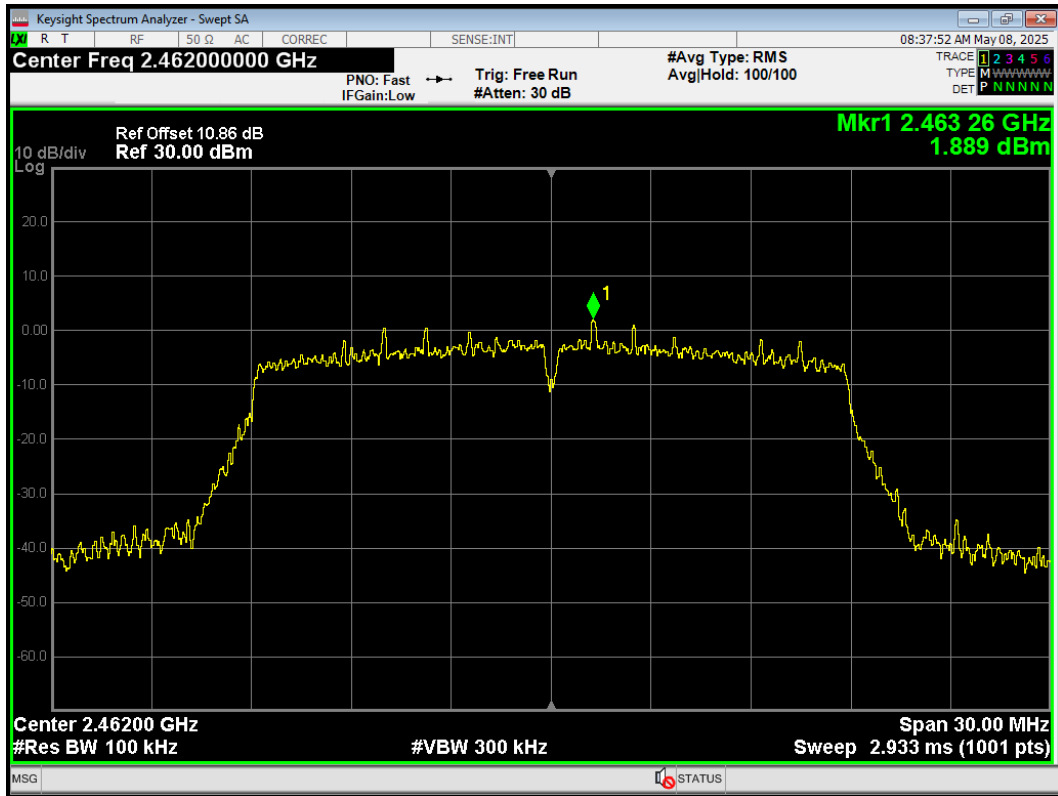

Band Edge 802.11n(HT20) 2462MHz Emission

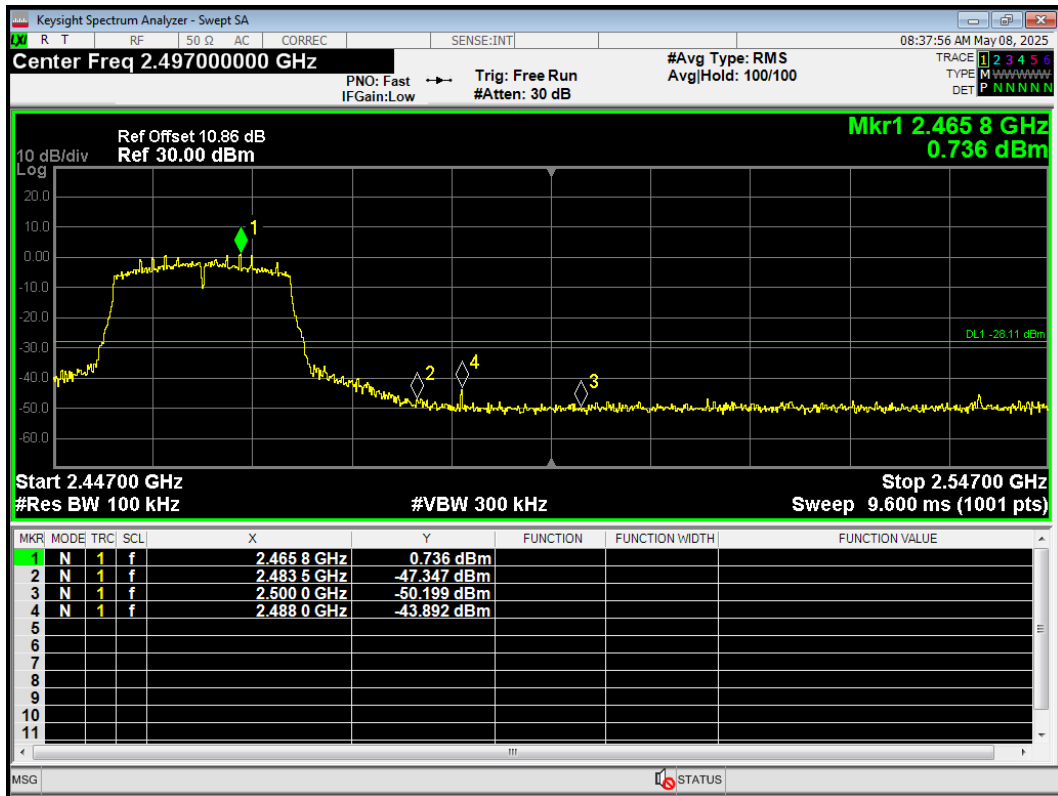

Band Edge 802.11n(HT40) 2422MHz Ref

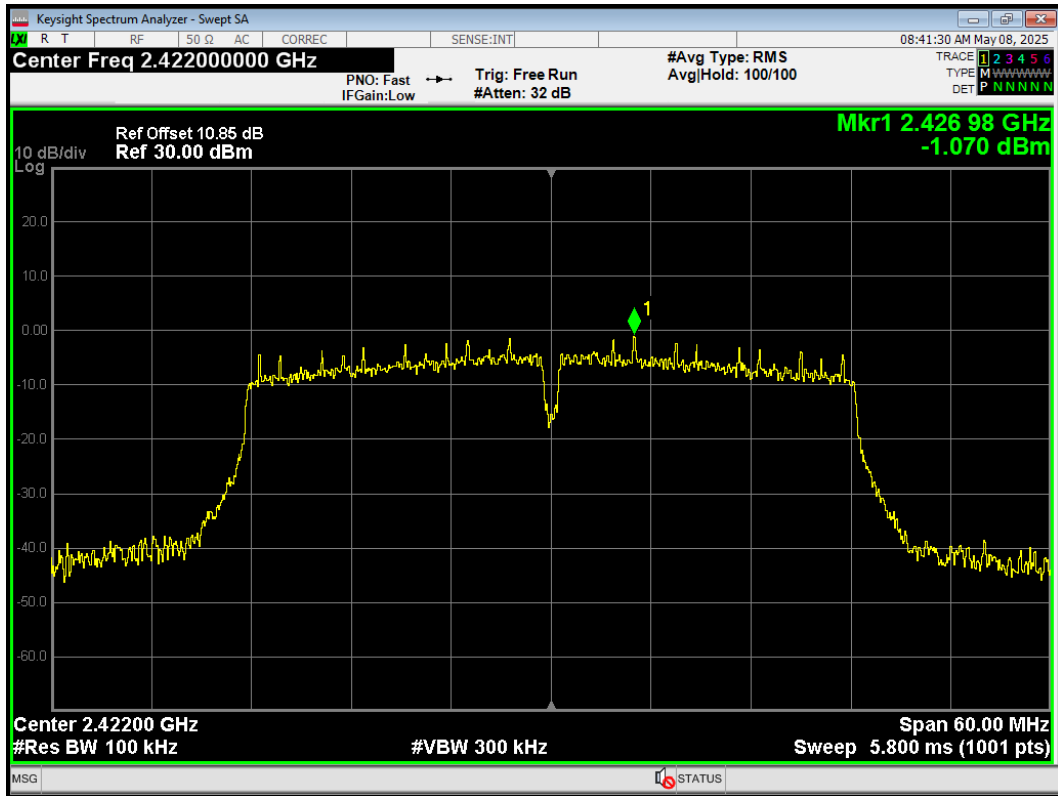

Band Edge 802.11n(HT40) 2422MHz Emission

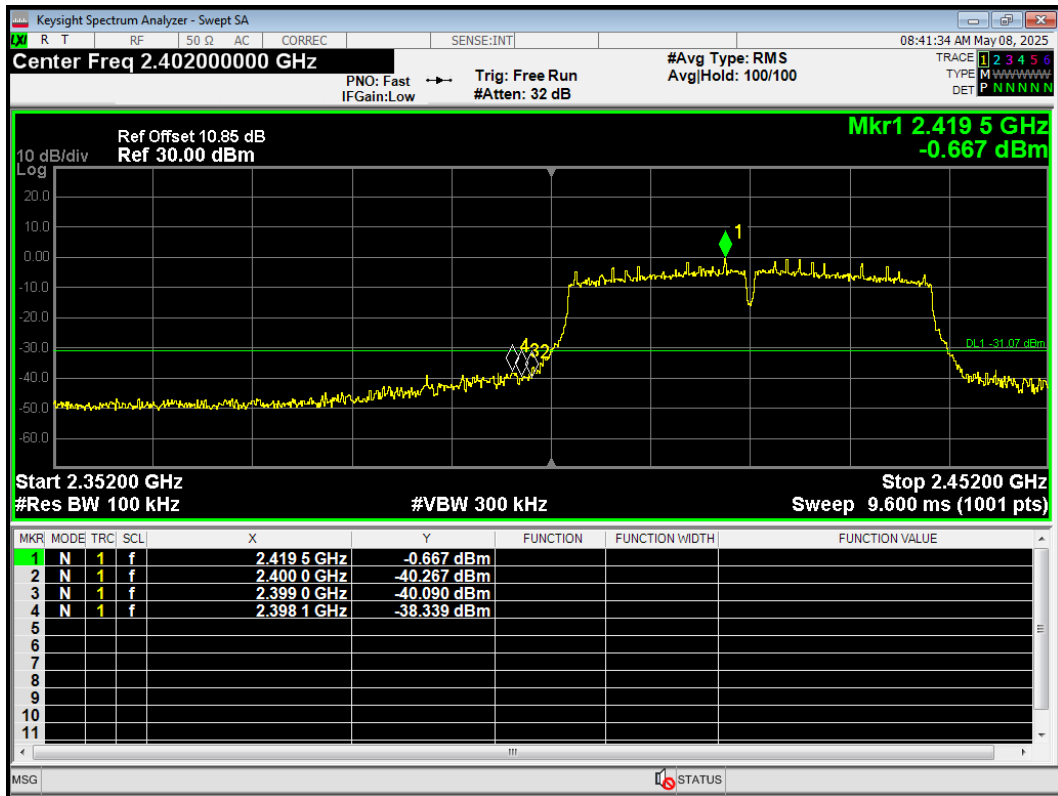

Band Edge 802.11n(HT40) 2452MHz Ref

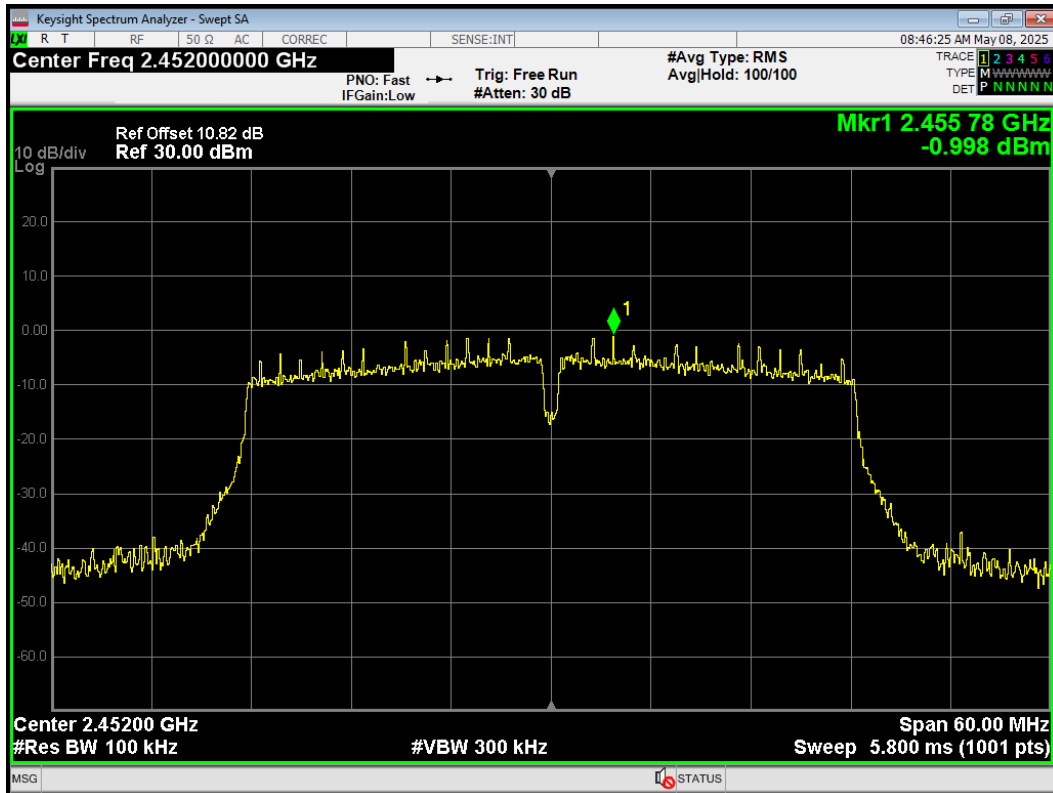

Band Edge 802.11n(HT40) 2452MHz Emission

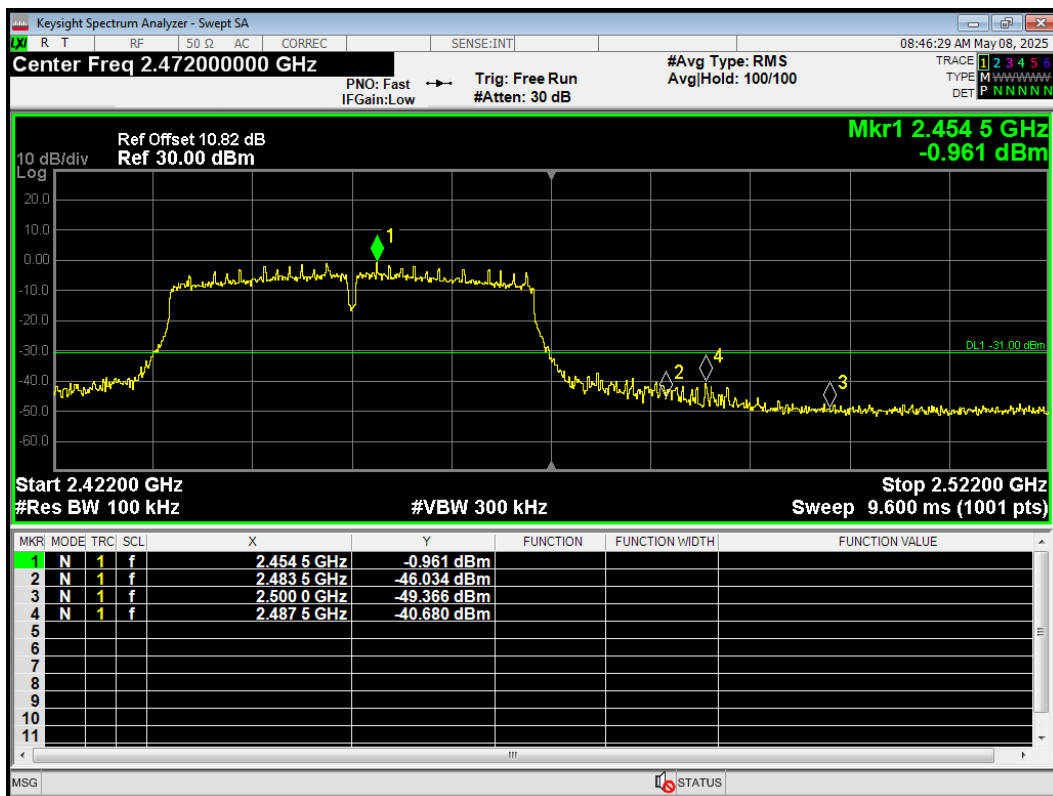

Band Edge BLE (1M) 2402MHz Ref

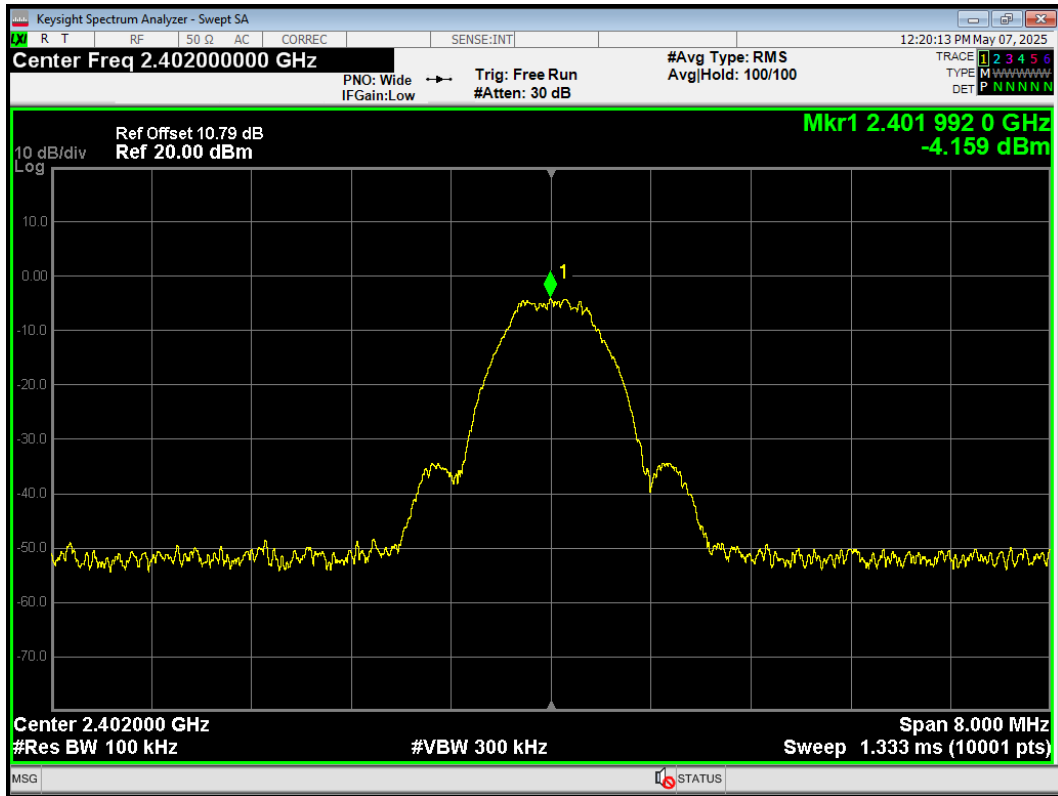

Band Edge BLE (1M) 2402MHz Emission

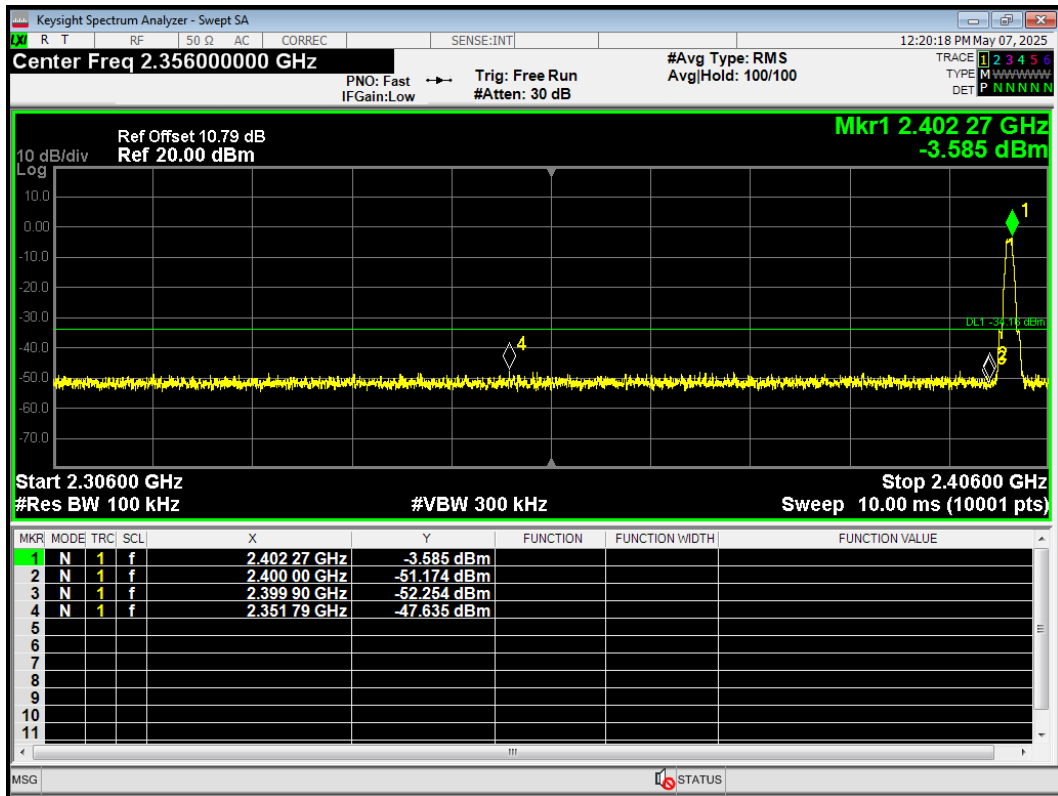

Band Edge BLE (1M) 2480MHz Ref

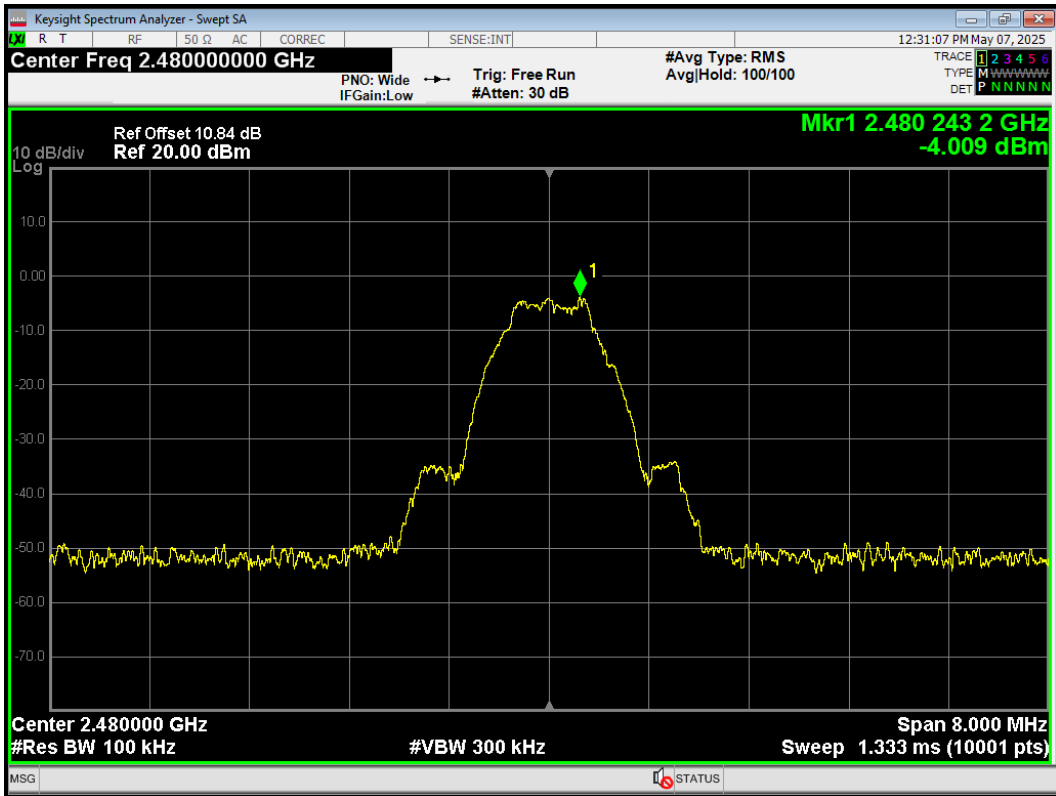

Band Edge BLE (1M) 2480MHz Emission

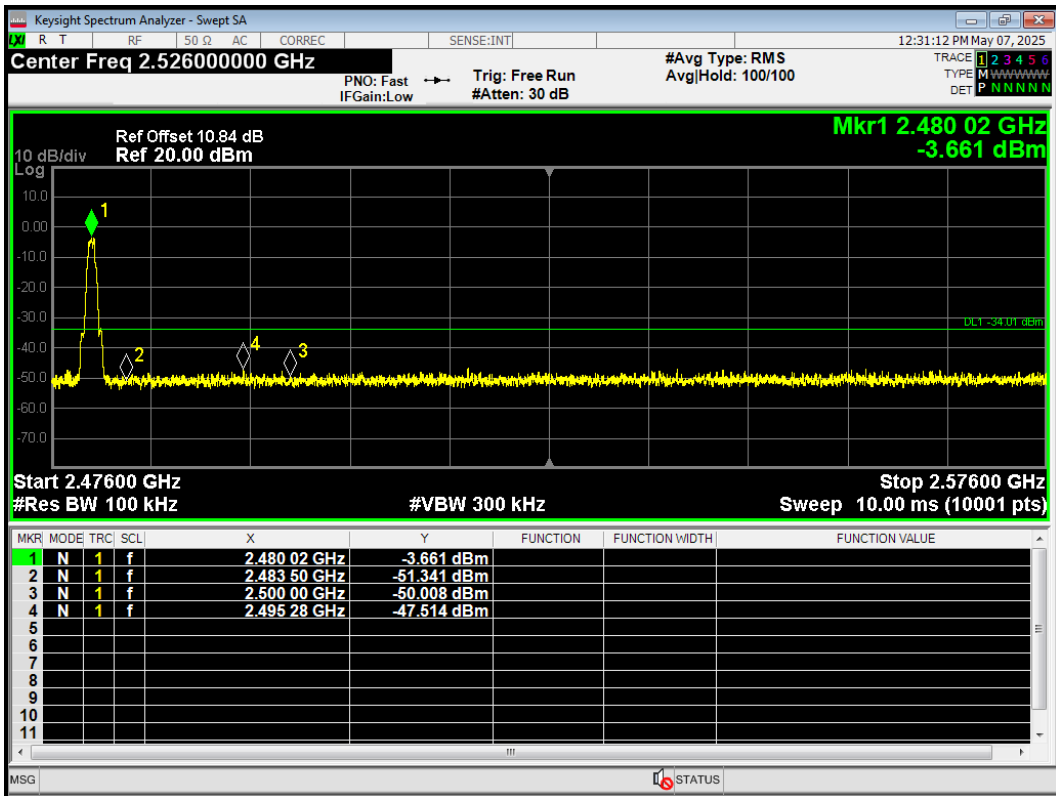

Band Edge BLE (2M) 2404MHz Ref

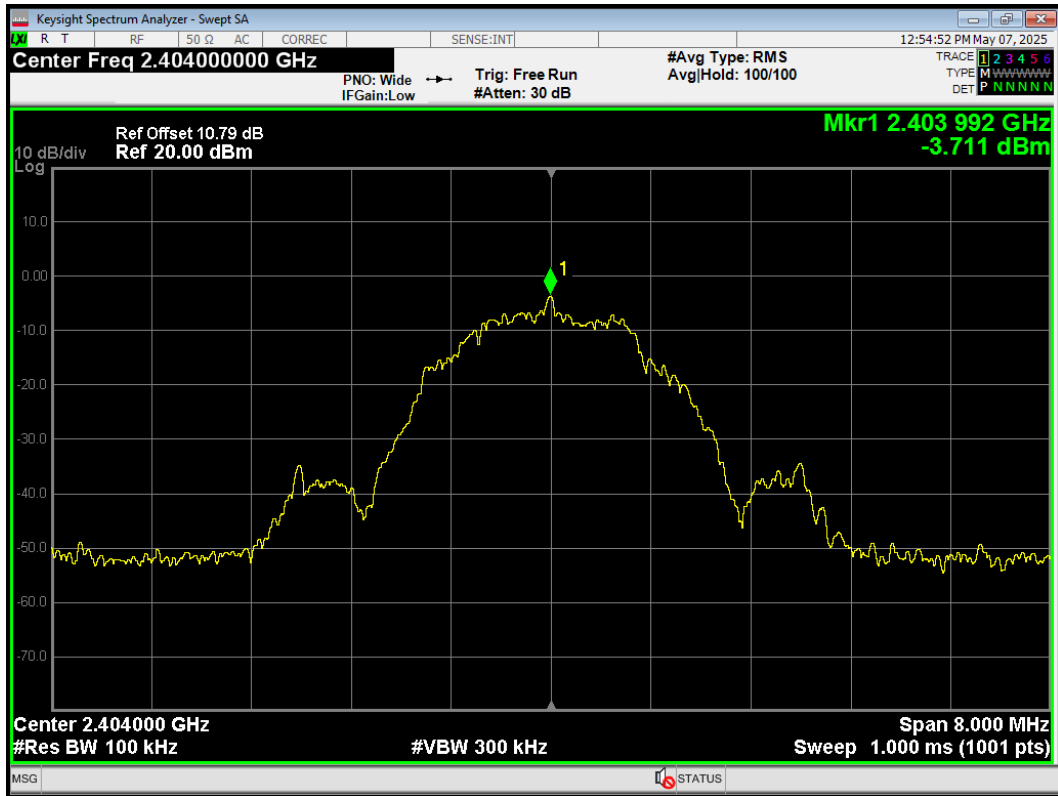

Band Edge BLE (2M) 2404MHz Emission

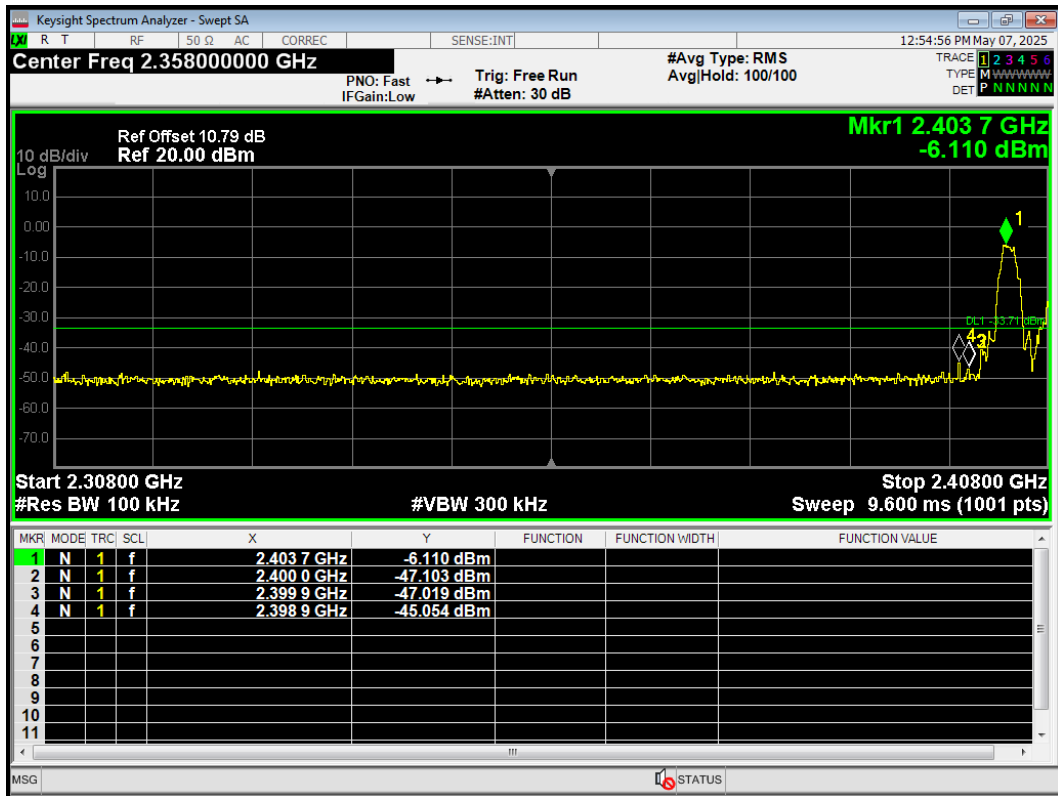

Band Edge BLE (2M) 2478MHz Ref

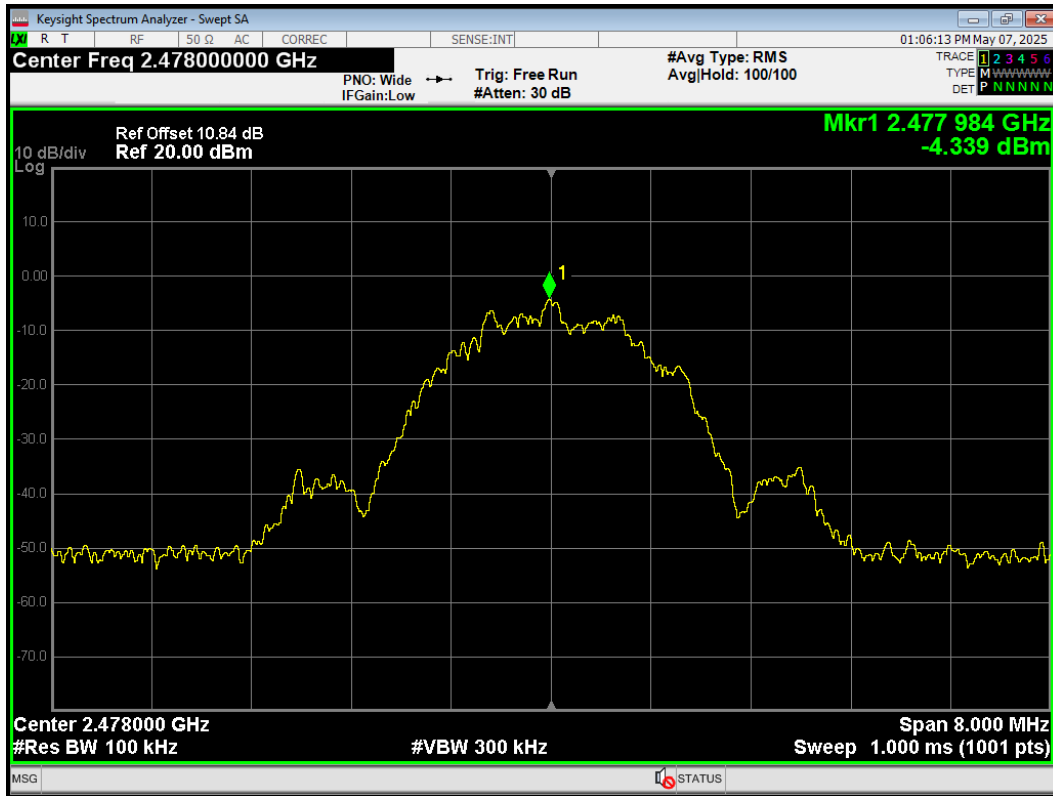

Band Edge BLE (2M) 2478MHz Emission

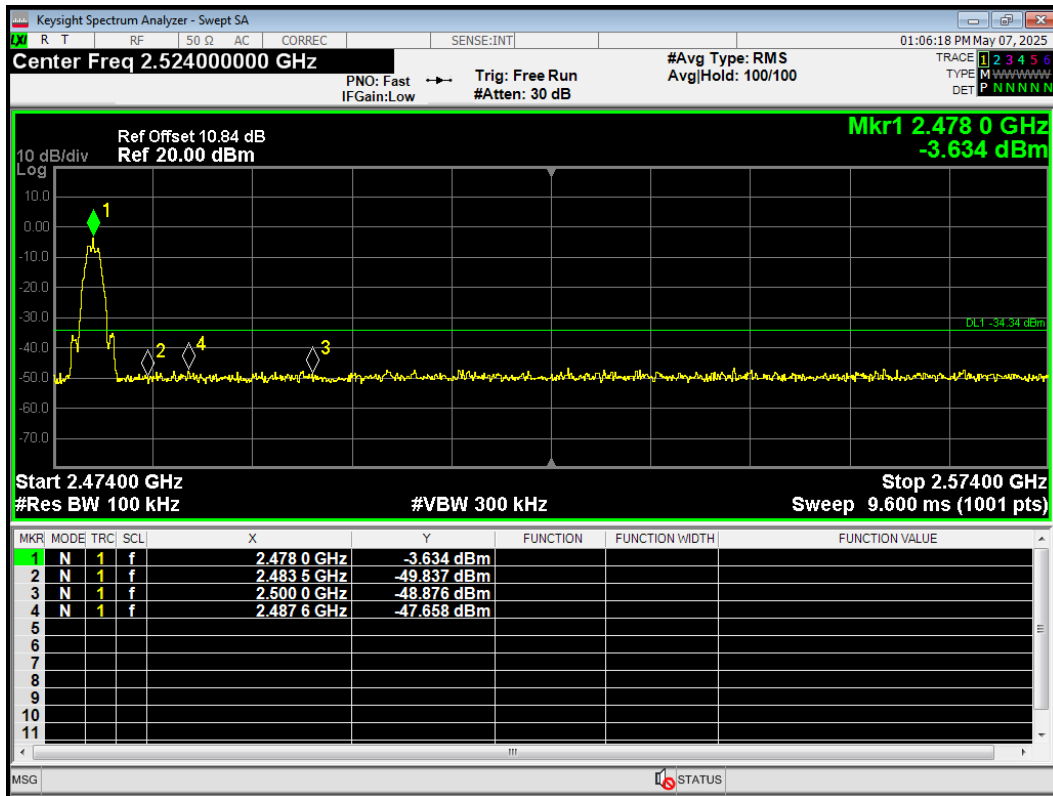

5.4. Power Spectral Density

Ambient Condition

Temperature	Relative humidity
15°C ~ 35°C	20% ~ 80%

Method of Measurement

During the process of the testing, The EUT was connected to Spectrum Analyzer with a known loss. The EUT is max power transmission with proper modulation.

Method AVGPSD-1 was used for this test.

- a) Set instrument center frequency to DTS channel center frequency
- b) Set span to at least 1.5 times the OBW
- c) Set RBW to: $3\text{kHz} \leq \text{RBW} \leq 100\text{kHz}$
- d) Set $\text{VBW} \geq [3 \times \text{RBW}]$
- e) Detector=power averaging (rms) or sample detector (when rms not available)
- f) Ensure that the number of measurement points in the sweep $\geq [2 \times \text{span}/\text{RBW}]$
- g) Sweep time auto couple
- h) Employ trace averaging (rms) mode over a minimum of 100 traces
- i) Use the peak marker function to determine the maximum amplitude level.
- j) If the measured value exceeds requirement, then reduce RBW (but no less than 3 kHz) and repeat (note that this may require zooming in on the emission of interest and reducing the span to meet the minimum measurement point requirement as the RBW is reduced)

Method AVGPSD-2 was used for this test.

- a) Measure the duty cycle (D)of the transmitter output signal as described in 11.6
- b) Set instrument center frequency to DTS channel center frequency
- c) Set span to at least 1.5 times the OBW
- d) Set RBW to: $3\text{kHz} \leq \text{RBW} \leq 100\text{kHz}$
- e) Set $\text{VBW} \geq [3 \times \text{RBW}]$
- f) Detector= power averaging (rms) or sample detector (when rms not available)
- g) Ensure that the number of measurement points in the sweep $\geq [2 \times \text{span}/\text{RBW}]$
- h) Sweep time =auto couple
- i) Do not use sweep triggering; allow sweep to "free run"
- j) Employ trace averaging (rms) mode over a minimum of 100 traces
- k) Use the peak marker function to determine the maximum amplitude level

l) Add $[10 \log(1/D)]$, where D is the duty cycle measured in step a), to the measured PSD to compute the average PSD during the actual transmission time

m) If measured value exceeds requirement specified by regulatory agency then reduce RBW (but no less than 3 kHz) and repeat (note that this may require zooming in on the emission of interest and reducing the span to meet the minimum measurement point requirement as the RBW is reduced)

Test setup

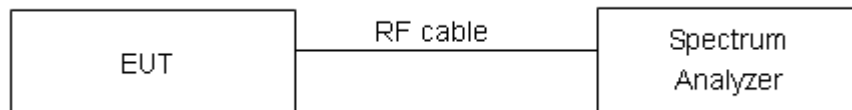

Limits

Rule Part 15.247(e) specifies that " For digitally modulated systems, the power spectral density conducted from the intentional radiator to the antenna shall not be greater than 8 dBm in any 3 kHz band during any time interval of continuous transmission. "

Limits	$\leq 8 \text{ dBm} / 3\text{kHz}$
--------	------------------------------------

Measurement Uncertainty

The assessed measurement uncertainty to ensure 95% confidence level for the normal distribution is with the coverage factor $k = 2$, $U = 0.75\text{dB}$.

Test Results:

Test Mode	Carrier frequency (MHz)/ Channel	Read Value (dBm / 30kHz)	Power Spectral Density (dBm / 3kHz)	Limit (dBm / 3kHz)	Conclusion
802.11b	2412/CH 1	-5.27	-15.27	8	PASS
	2437/CH 6	-5.28	-15.28	8	PASS
	2462/CH11	-5.34	-15.34	8	PASS
802.11g	2412/CH 1	-9.74	-19.63	8	PASS
	2437/CH 6	-9.63	-19.52	8	PASS
	2462/CH11	-9.50	-19.39	8	PASS
802.11n HT20	2412/CH 1	-12.00	-21.88	8	PASS
	2437/CH 6	-11.58	-21.46	8	PASS
	2462/CH11	-11.82	-21.70	8	PASS
802.11n HT40	2422/CH3	-14.27	-24.04	8	PASS
	2437/CH6	-13.98	-23.75	8	PASS
	2452/CH9	-13.59	-23.36	8	PASS

Note: Power Spectral Density (dBm/3kHz) =Read Value+Duty cycle correction factor + 10*log10(3/30)

Test Mode	Carrier frequency (MHz)/ Channel	Read Value (dBm / 3kHz)	Power Spectral Density (dBm / 3kHz)	Limit (dBm / 3kHz)	Conclusion
Bluetooth (Low Energy) (1M)	2402/CH0	-23.07	-22.37	8	PASS
	2440/CH19	-22.23	-21.53	8	PASS
	2480/CH39	-22.24	-21.54	8	PASS
Bluetooth (Low Energy) (2M)	2404/CH1	-26.48	-21.49	8	PASS
	2440/CH19	-26.70	-21.71	8	PASS
	2478/CH38	-26.62	-21.63	8	PASS

Note: Power Spectral Density =Read Value+Duty cycle correction factor

PSD 802.11b 2412MHz

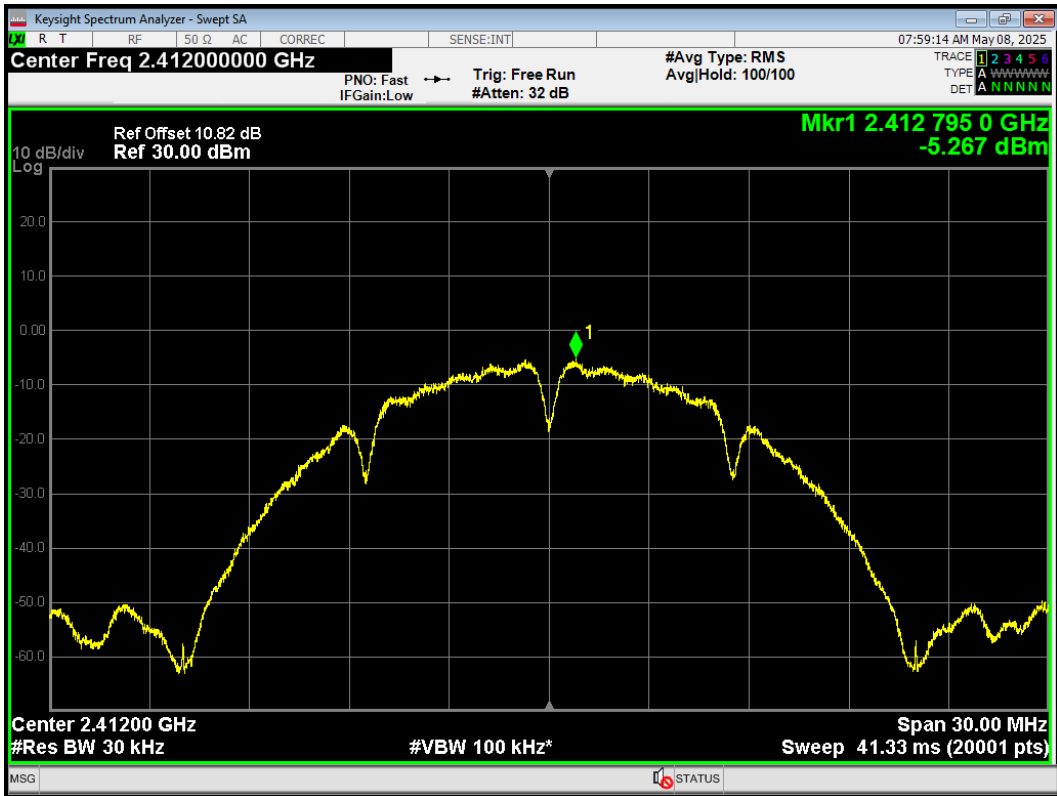

PSD 802.11b 2437MHz

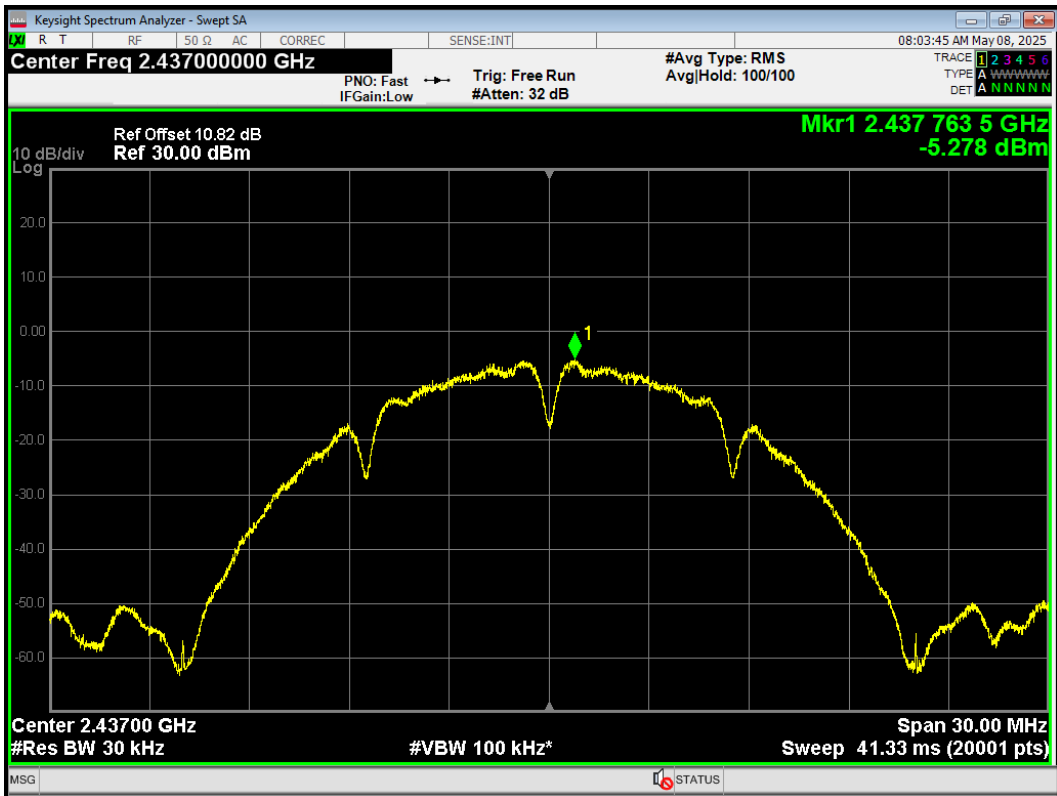

PSD 802.11b 2462MHz

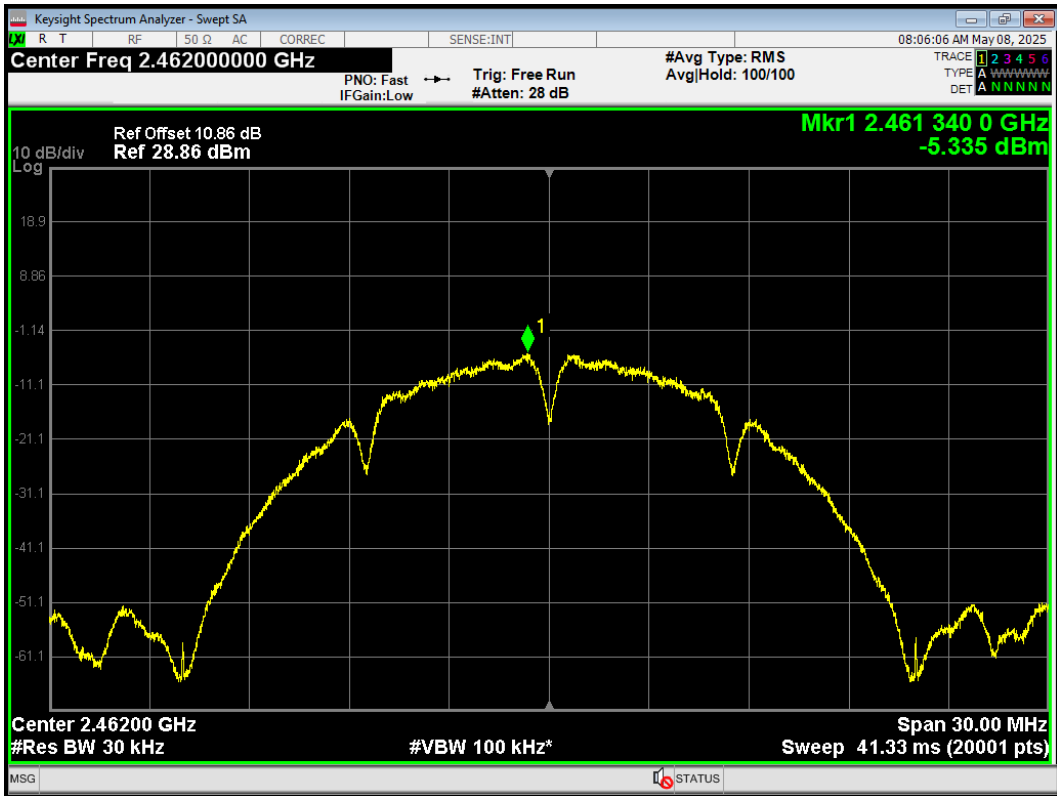

PSD 802.11g 2412MHz

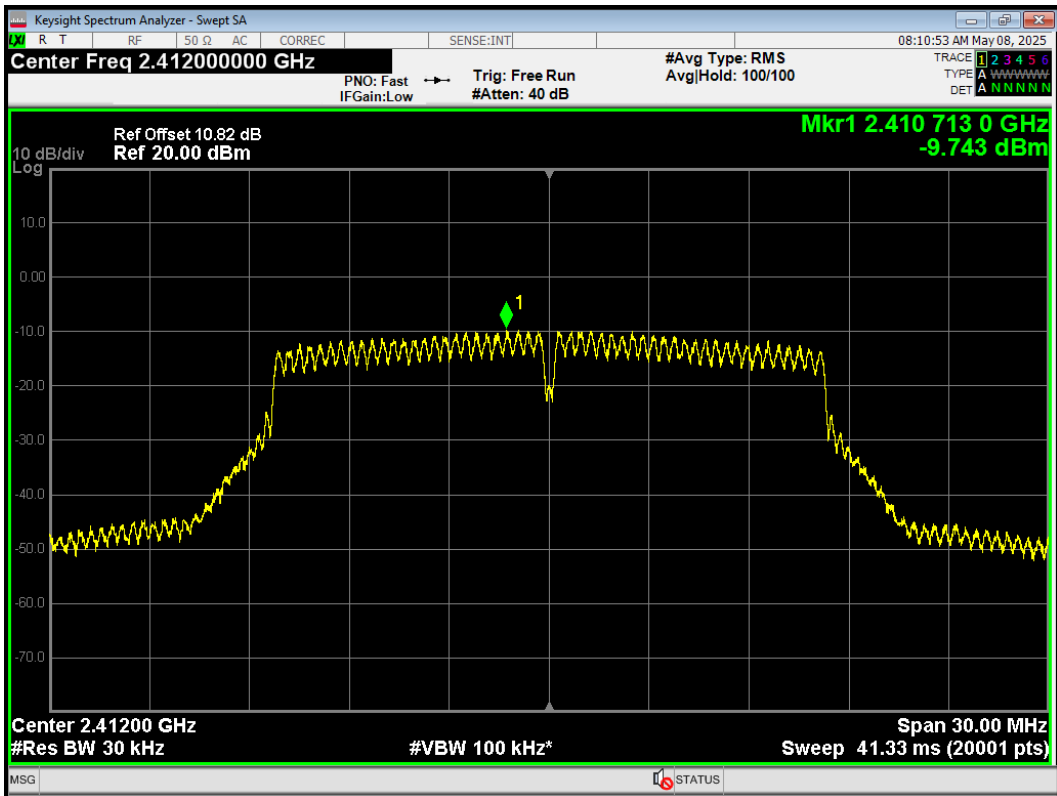

PSD 802.11g 2437MHz

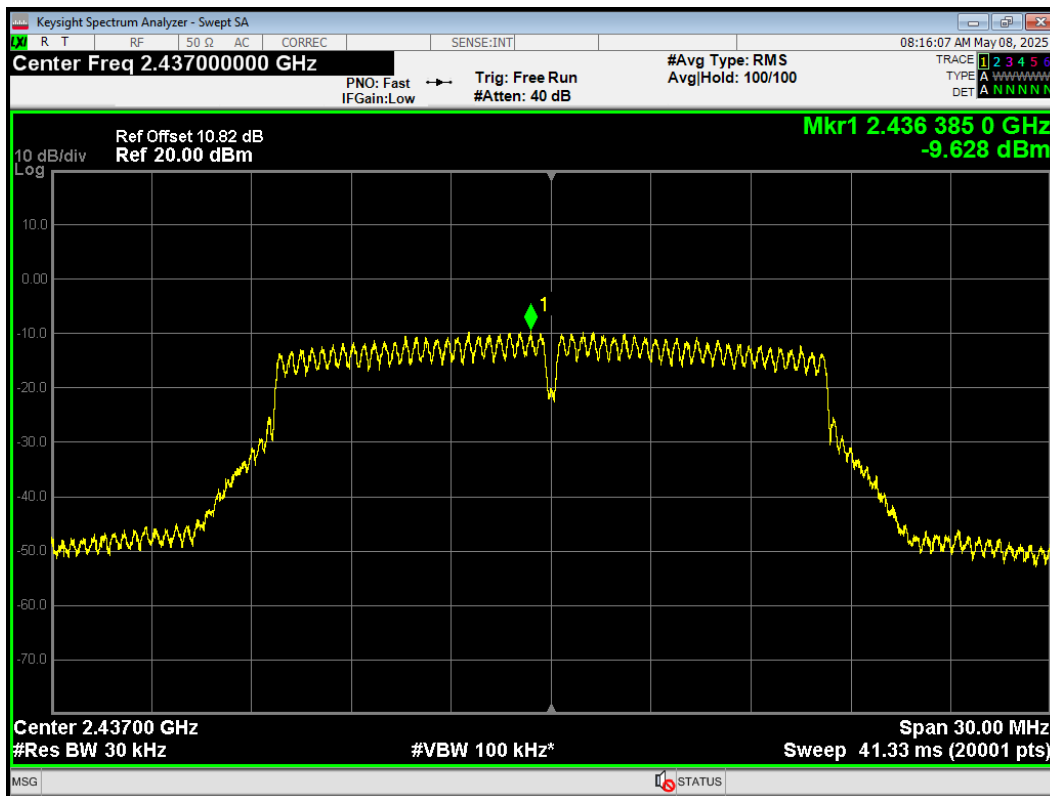

PSD 802.11g 2462MHz

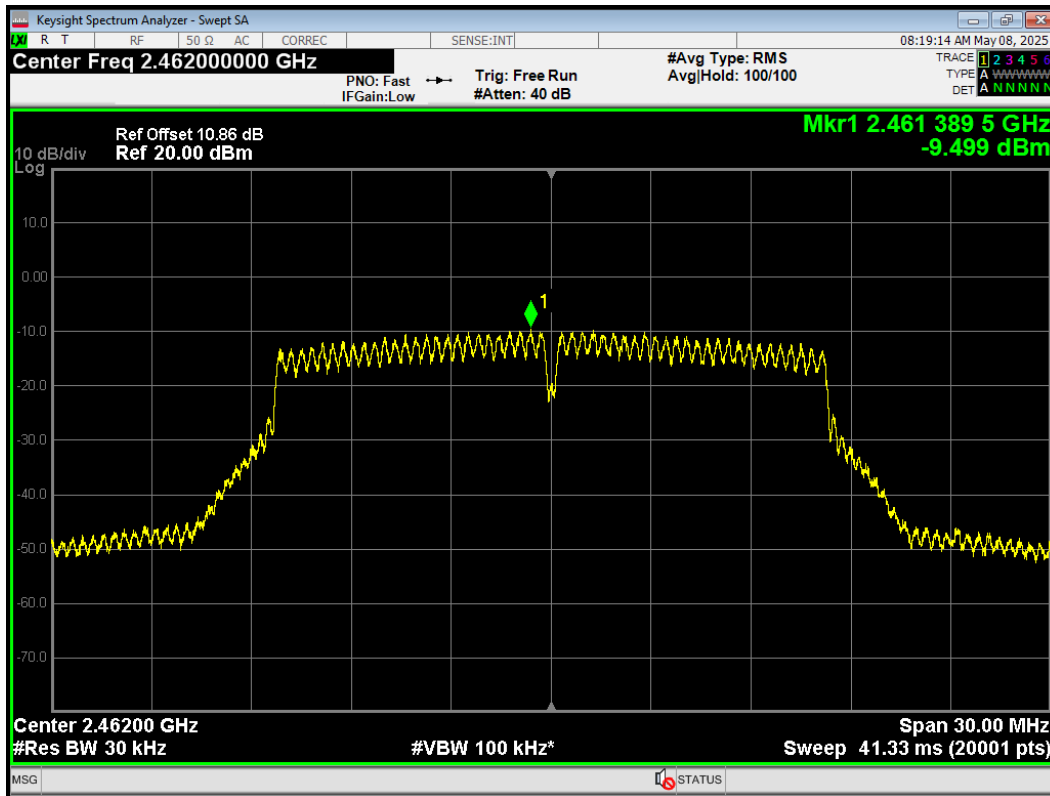

PSD 802.11n(HT20) 2412MHz

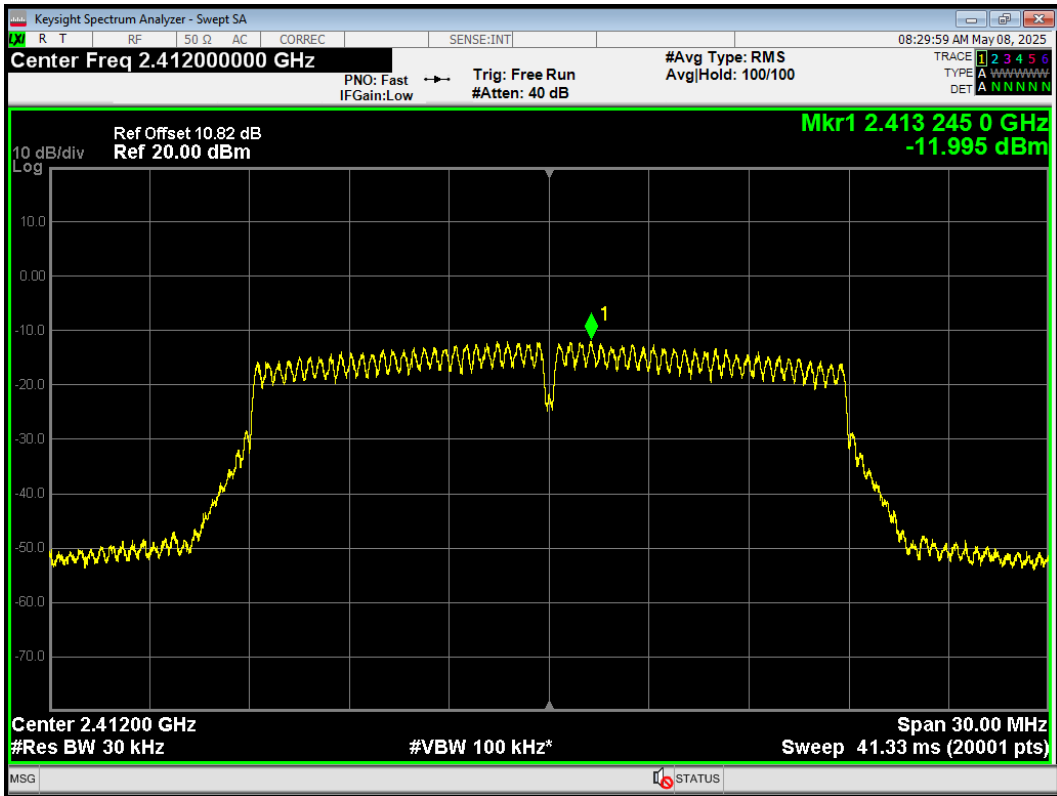

PSD 802.11n(HT20) 2437MHz

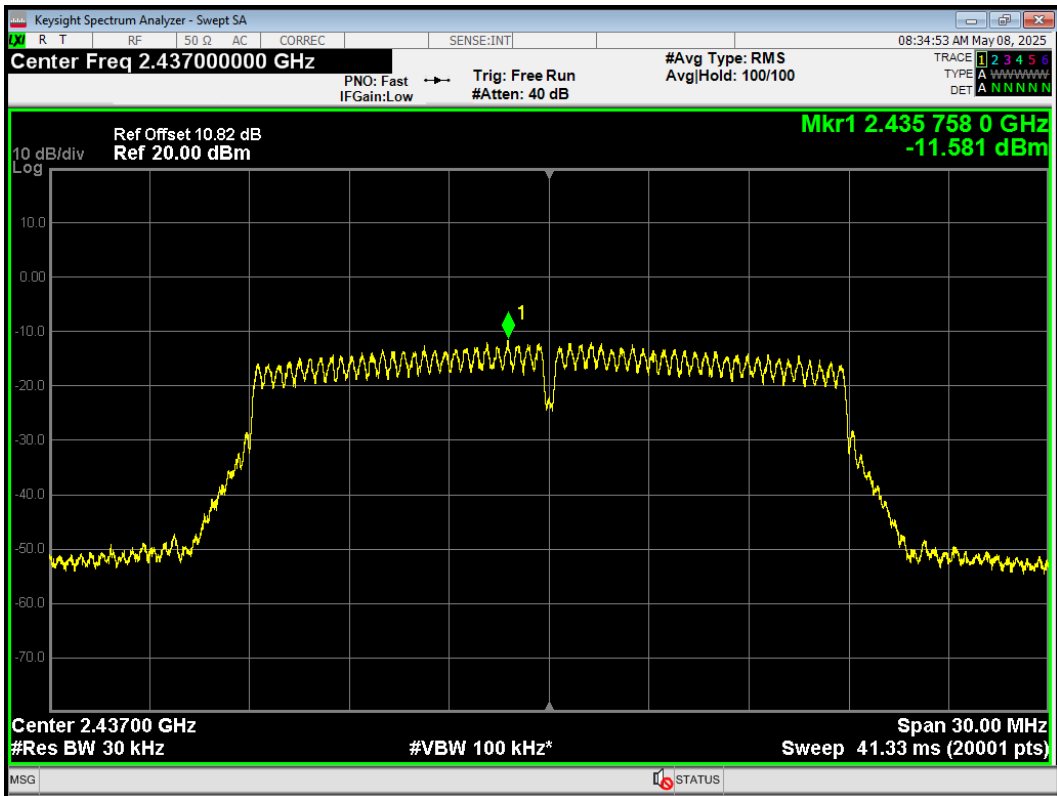

PSD 802.11n(HT20) 2462MHz

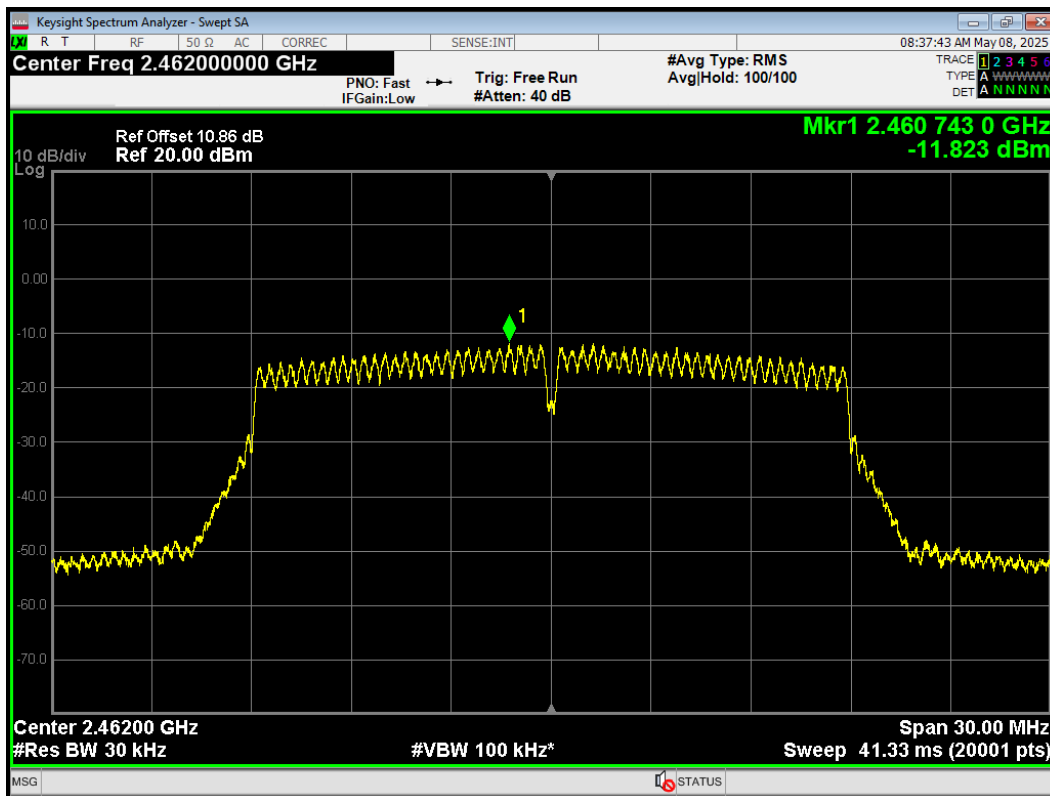

PSD 802.11n(HT40) 2422MHz

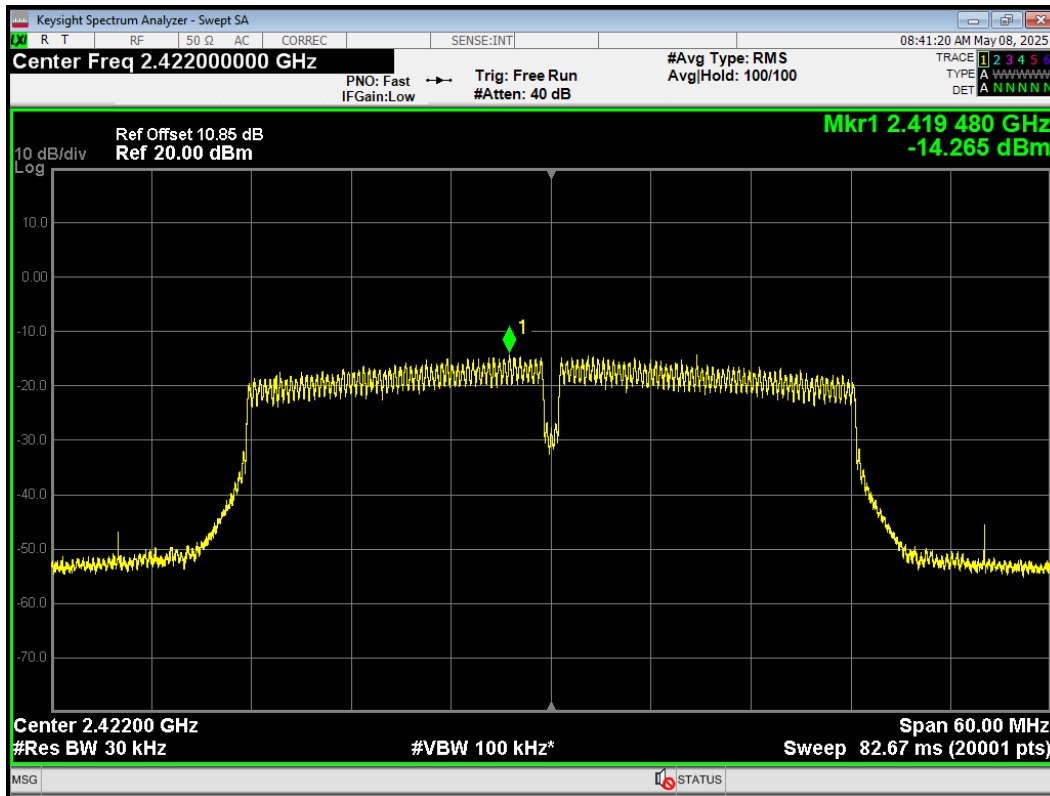

PSD 802.11n(HT40) 2437MHz

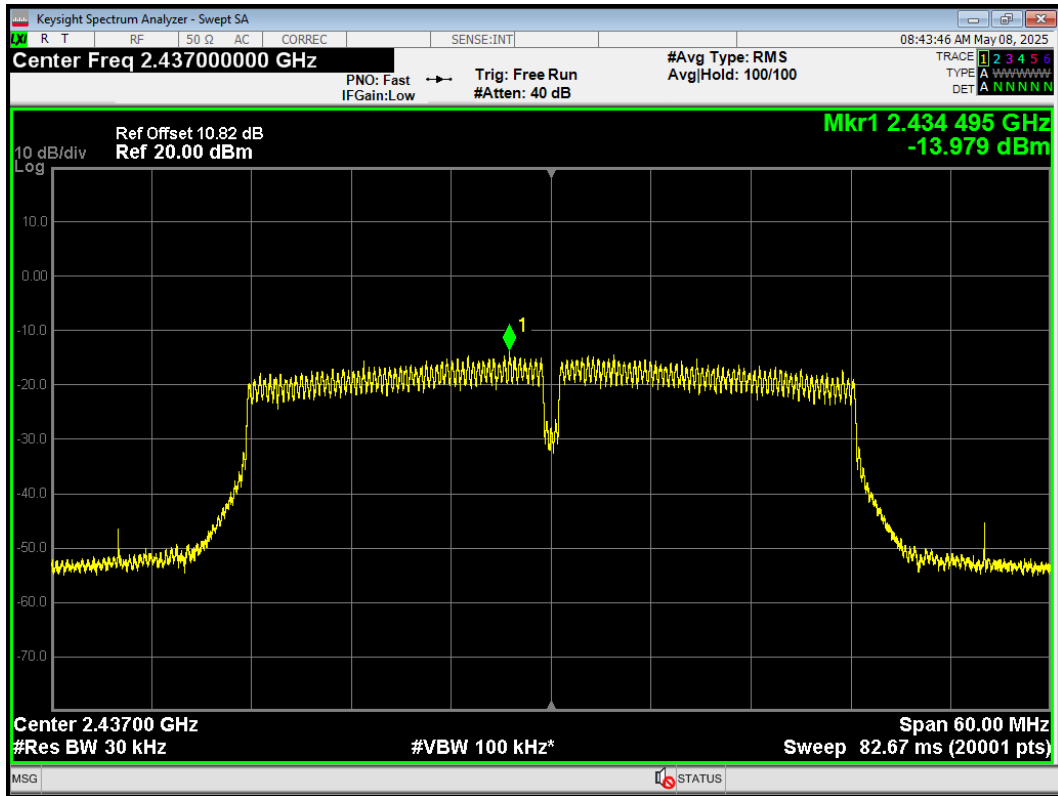

PSD 802.11n(HT40) 2452MHz

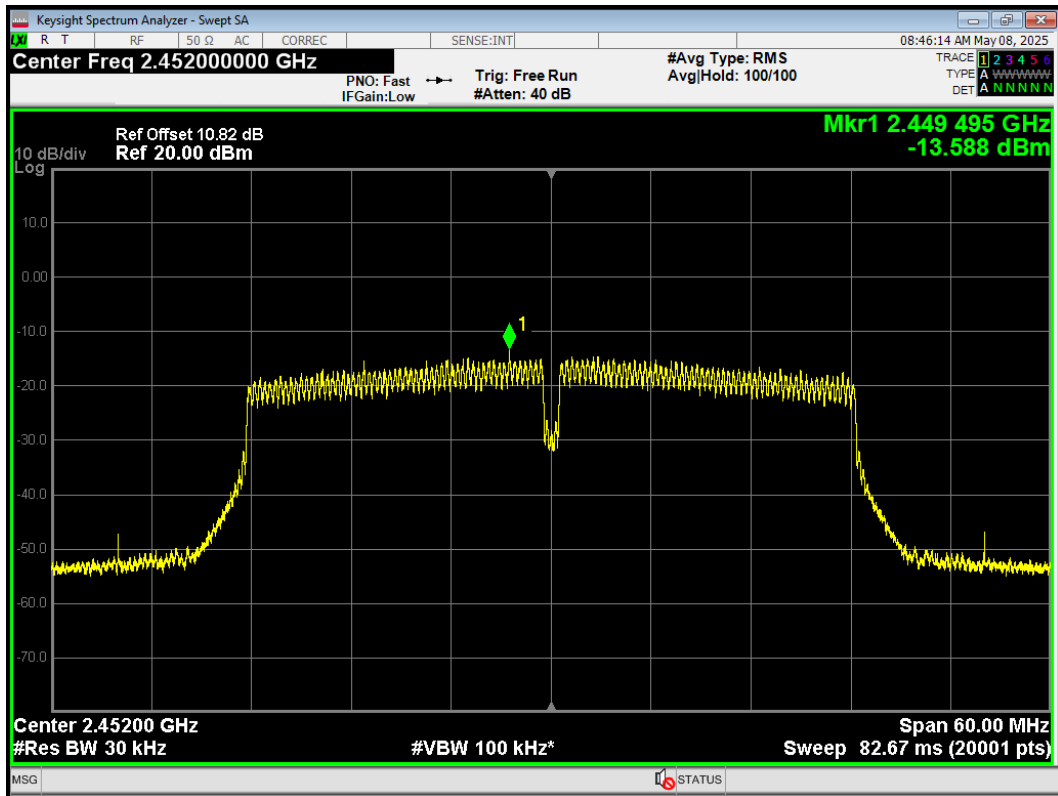

PSD BLE (1M) 2402MHz

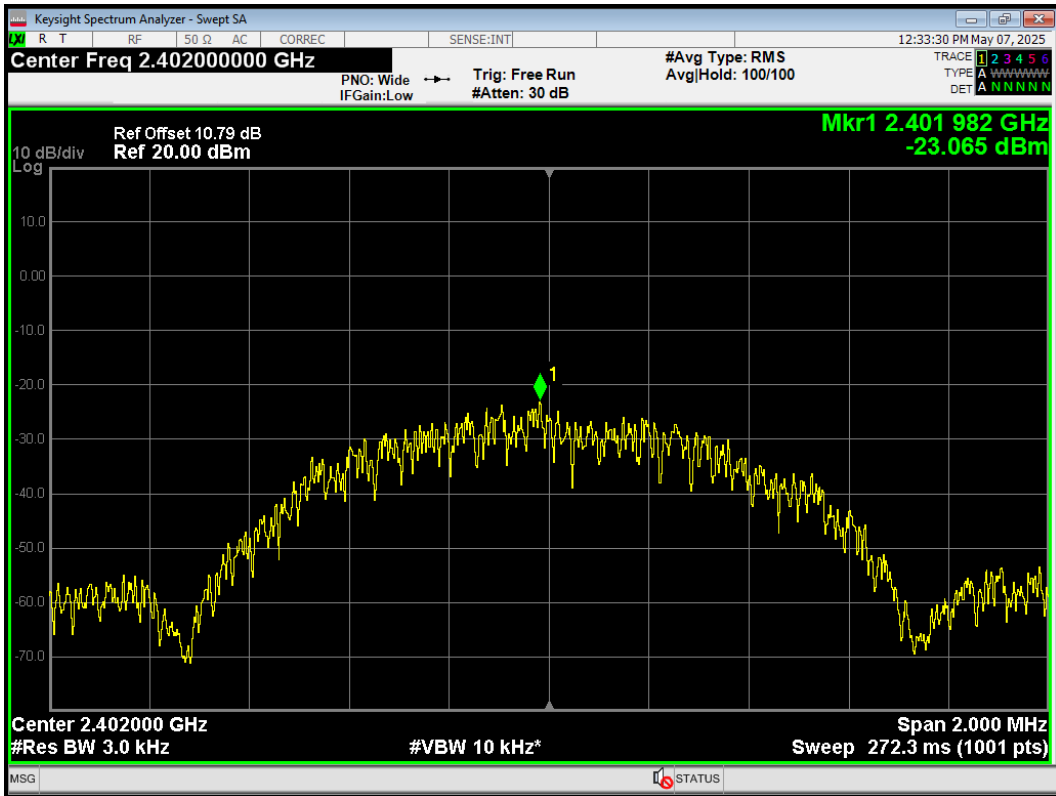

PSD BLE (1M) 2440MHz

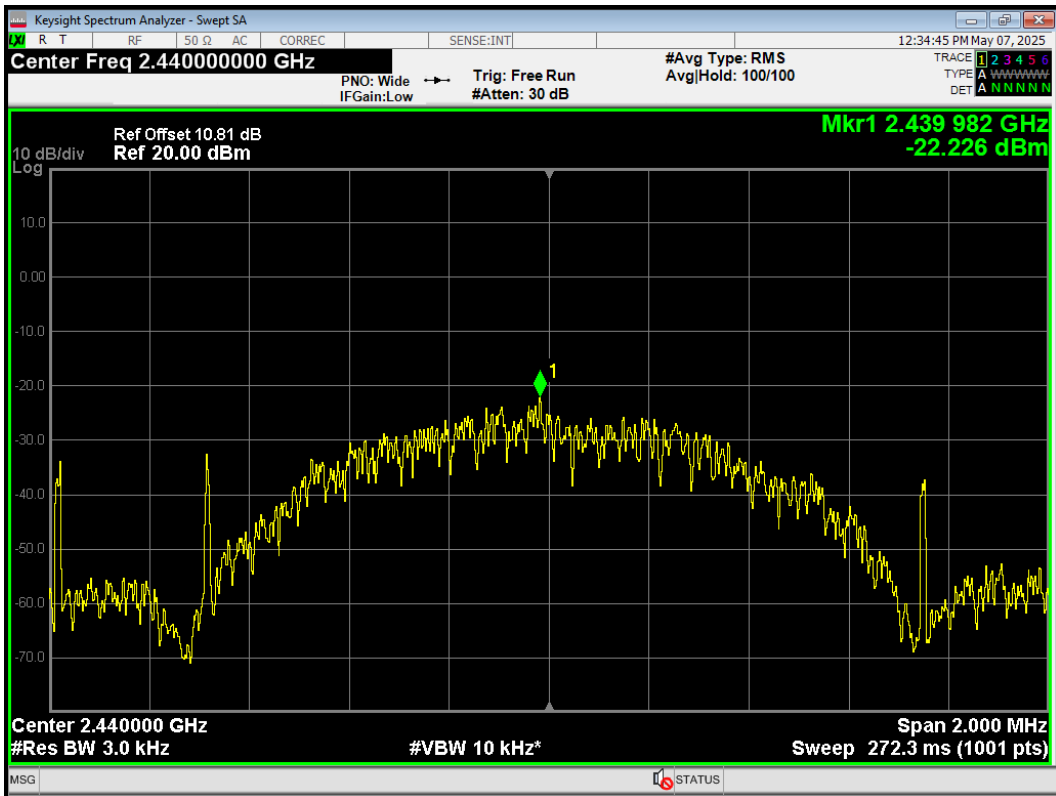

PSD BLE (1M) 2480MHz

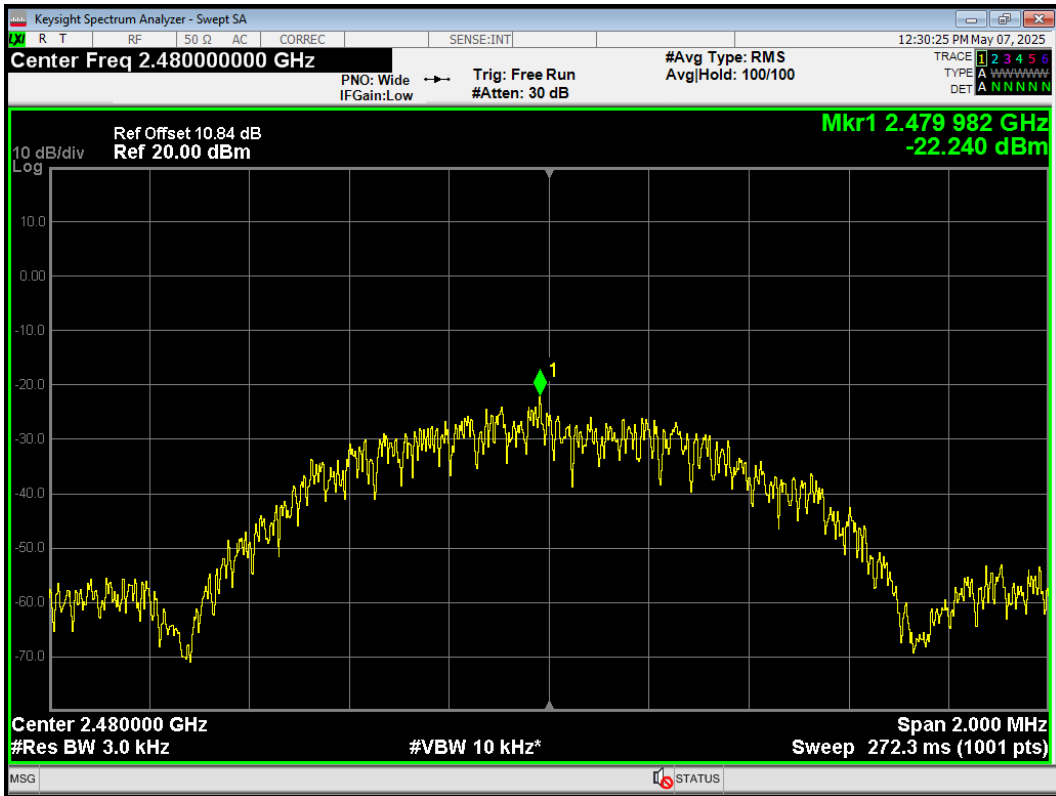

PSD BLE (2M) 2404MHz

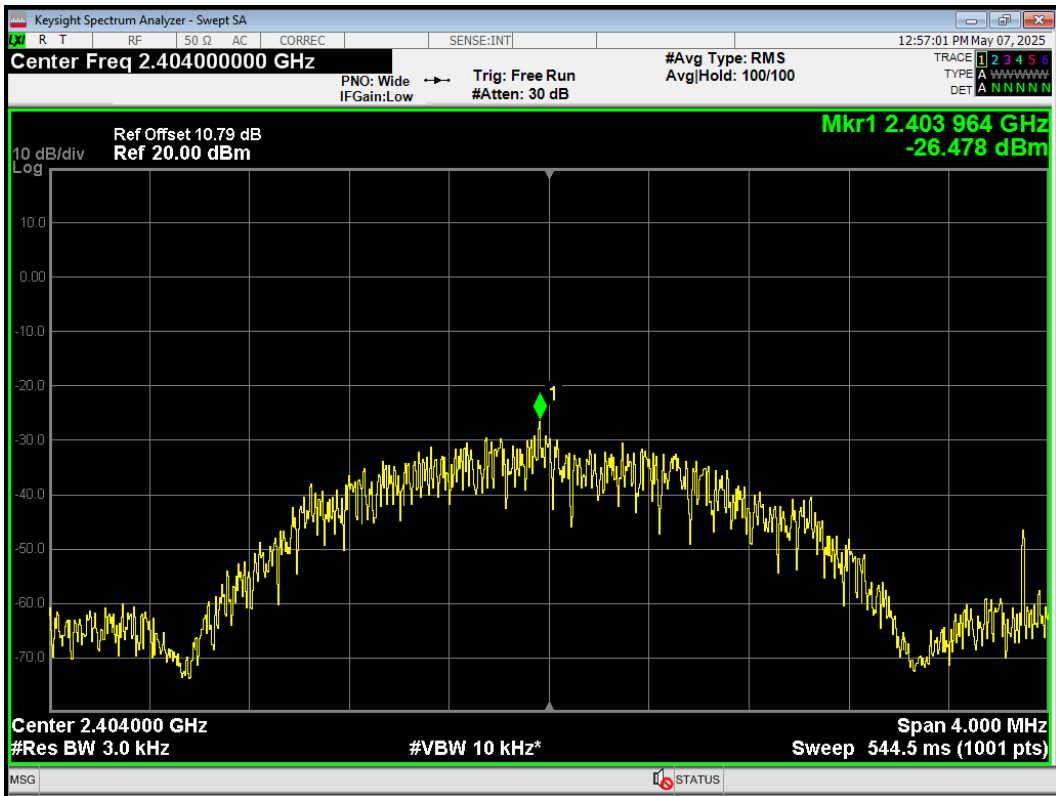

PSD BLE (2M) 2440MHz

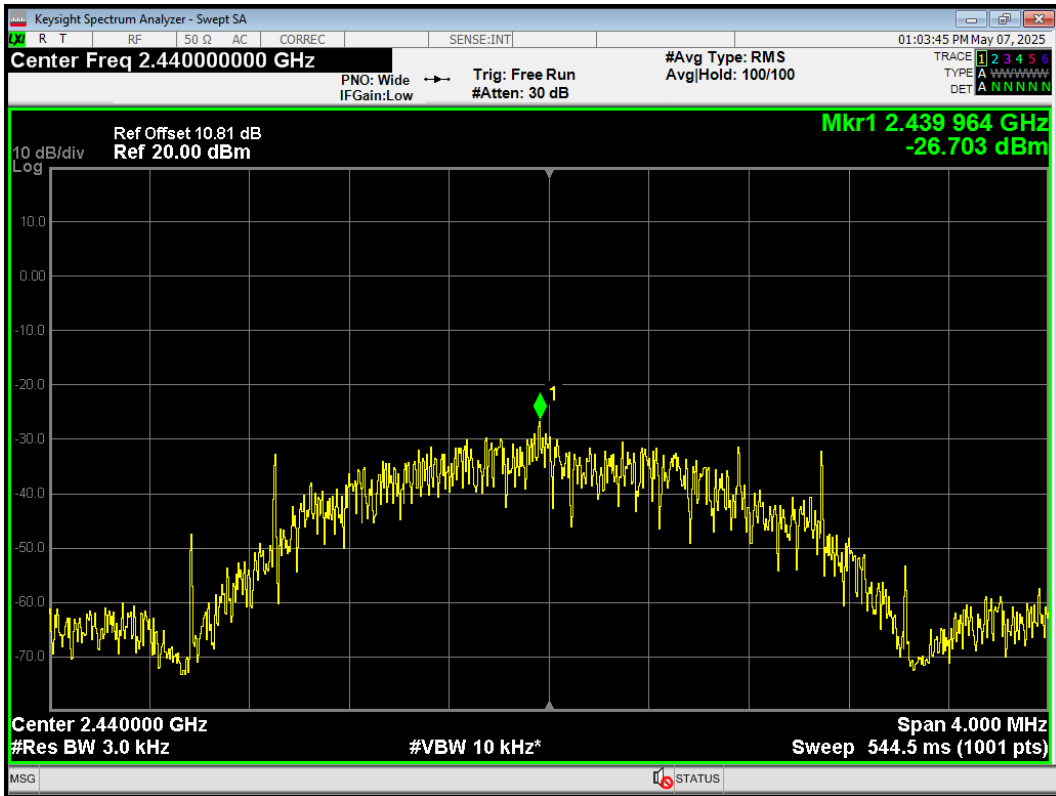

PSD BLE (2M) 2478MHz

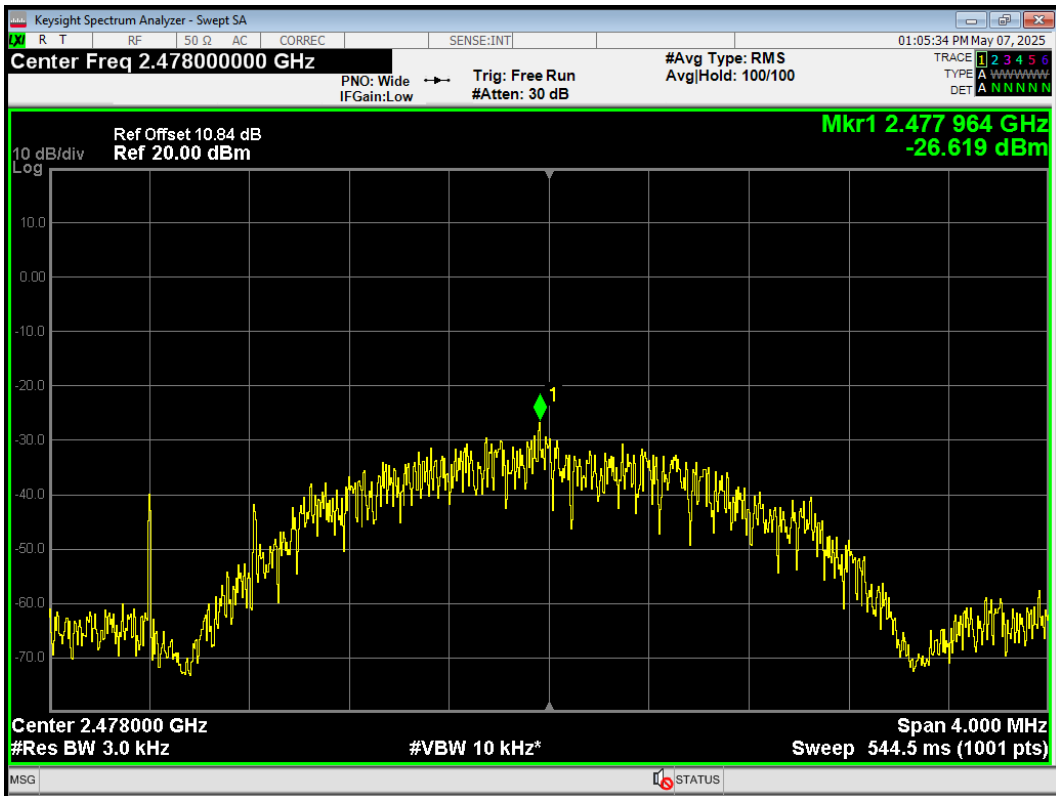

5.5. Spurious RF Conducted Emissions

Ambient Condition

Temperature	Relative humidity
15°C ~ 35°C	20% ~ 80%

Method of Measurement

The EUT was connected to the spectrum analyzer with a known loss. The spectrum analyzer scans from 30MHz to the 10th harmonic of the carrier. The peak detector is used. Set RBW to 100 kHz and VBW to 300 kHz, Sweep is set to AUTO.

The test is in transmitting mode.

Test Setup

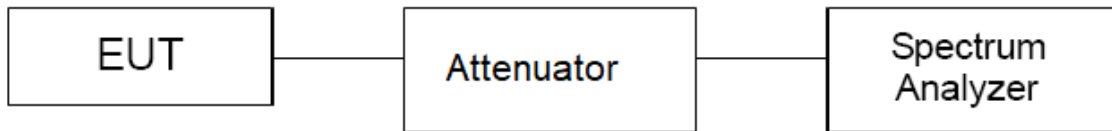

Limits

Rule Part 15.247(d) specifies that “In any 100 kHz bandwidth outside the frequency band in which the spread spectrum or digitally modulated intentional radiator is operating, the radio frequency power that is produced by the intentional radiator shall be at least 20 dB below that in the 100 kHz bandwidth within the band that contains the highest level of the desired power, based on either an RF conducted or a radiated measurement, provided the transmitter demonstrates compliance with the peak conducted power limits. If the transmitter complies with the conducted power limits based on the use of RMS averaging over a time interval, as permitted under paragraph (b)(3) of this section, the attenuation required under this paragraph shall be 30 dB instead of 20 dB.”

Test Mode	Carrier frequency (MHz)/ Channel	Reference value (dBm)	Limit
802.11b	2412/CH 1	7.560	-22.44
	2437/CH 6	7.270	-22.73
	2462/CH11	7.360	-22.64
802.11g	2412/CH 1	2.370	-27.63
	2437/CH 6	3.310	-26.69
	2462/CH11	3.310	-26.69
802.11n HT20	2412/CH 1	1.360	-28.64
	2437/CH 6	0.800	-29.20
	2462/CH11	2.080	-27.92

802.11n HT40	2422/CH3	-1.100	-31.10
	2437/CH6	-0.790	-30.79
	2452/CH9	-0.690	-30.69
Bluetooth (Low Energy) (1M)	2402/CH0	-3.100	-33.10
	2440/CH19	-3.140	-33.14
	2480/CH39	-3.620	-33.62
Bluetooth (Low Energy) (2M)	2404/CH1	-3.620	-33.62
	2440/CH19	-3.640	-33.64
	2478/CH38	-3.880	-33.88

Measurement Uncertainty

The assessed measurement uncertainty to ensure 95% confidence level for the normal distribution is with the coverage factor $k = 1.96$.

Frequency	Uncertainty
100kHz-2GHz	0.684 dB
2GHz-26GHz	1.407 dB

Test Results:

Tx. Spurious 802.11b 2412MHz Ref

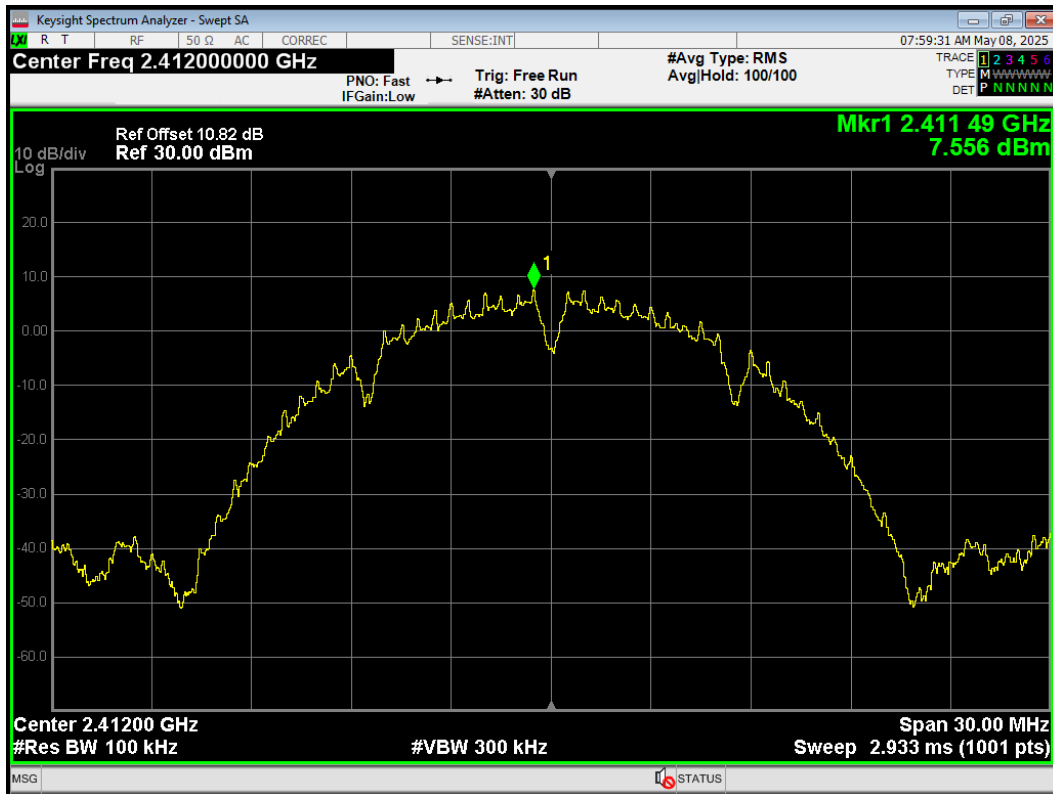

Tx. Spurious 802.11b 2412MHz Emission

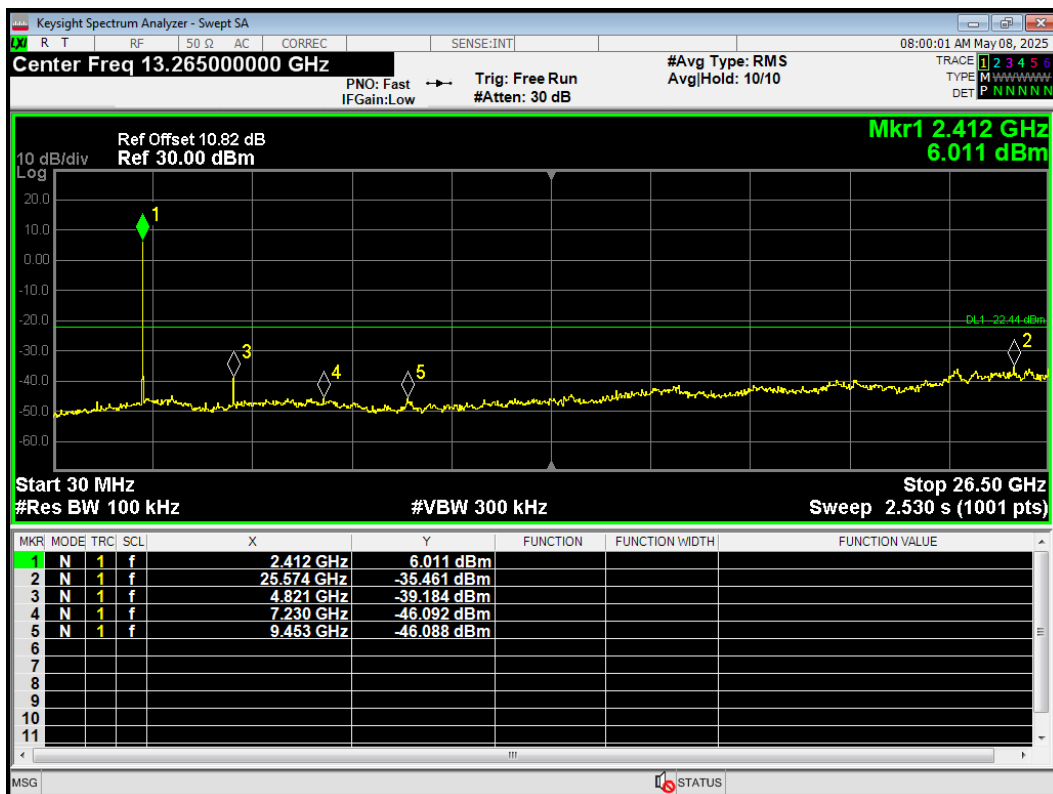

Tx. Spurious 802.11b 2437MHz Ref

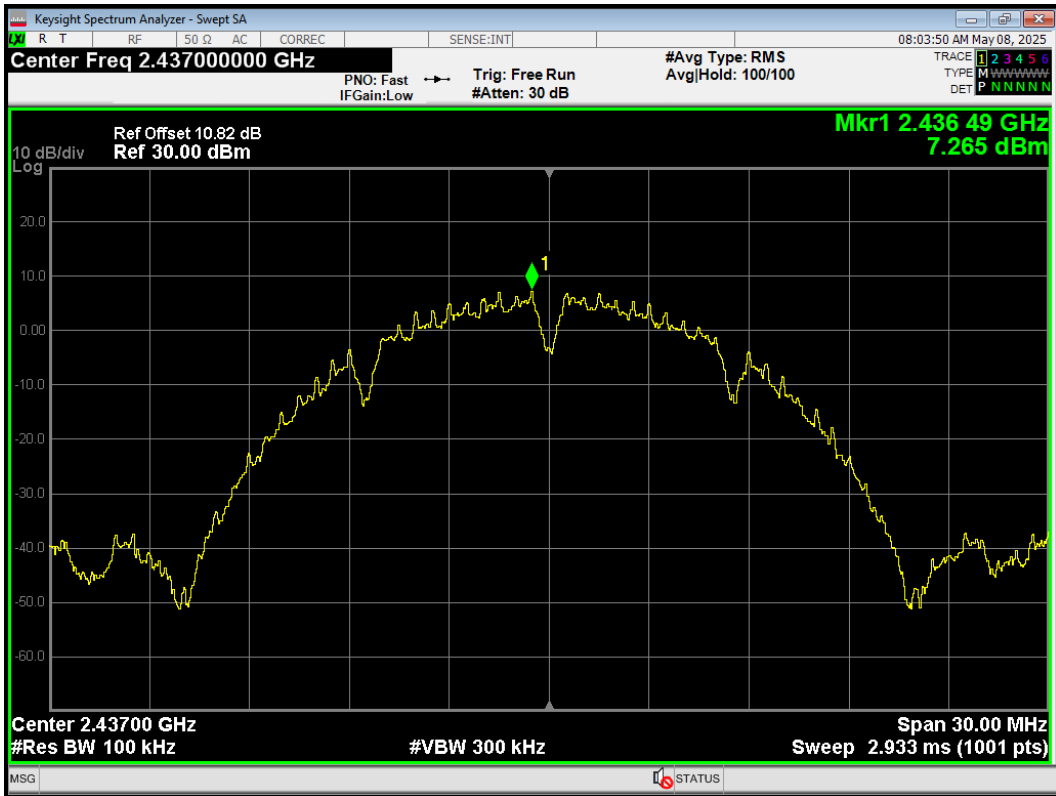

Tx. Spurious 802.11b 2437MHz Emission

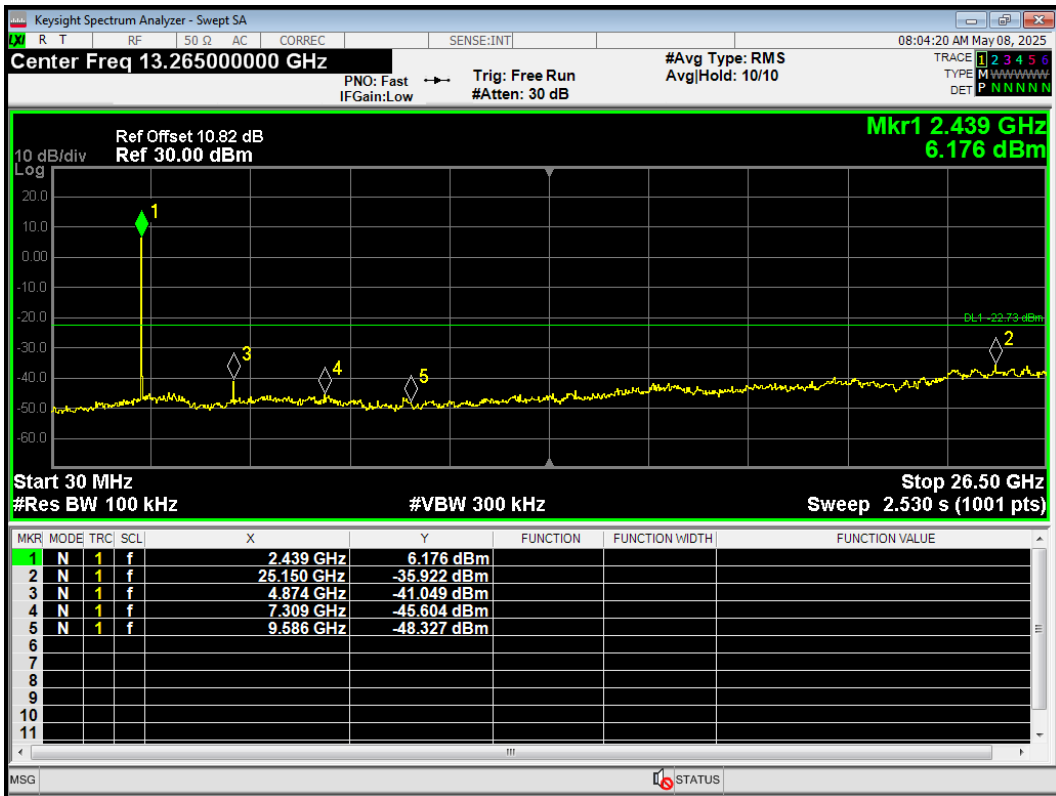

Tx. Spurious 802.11b 2462MHz Ref

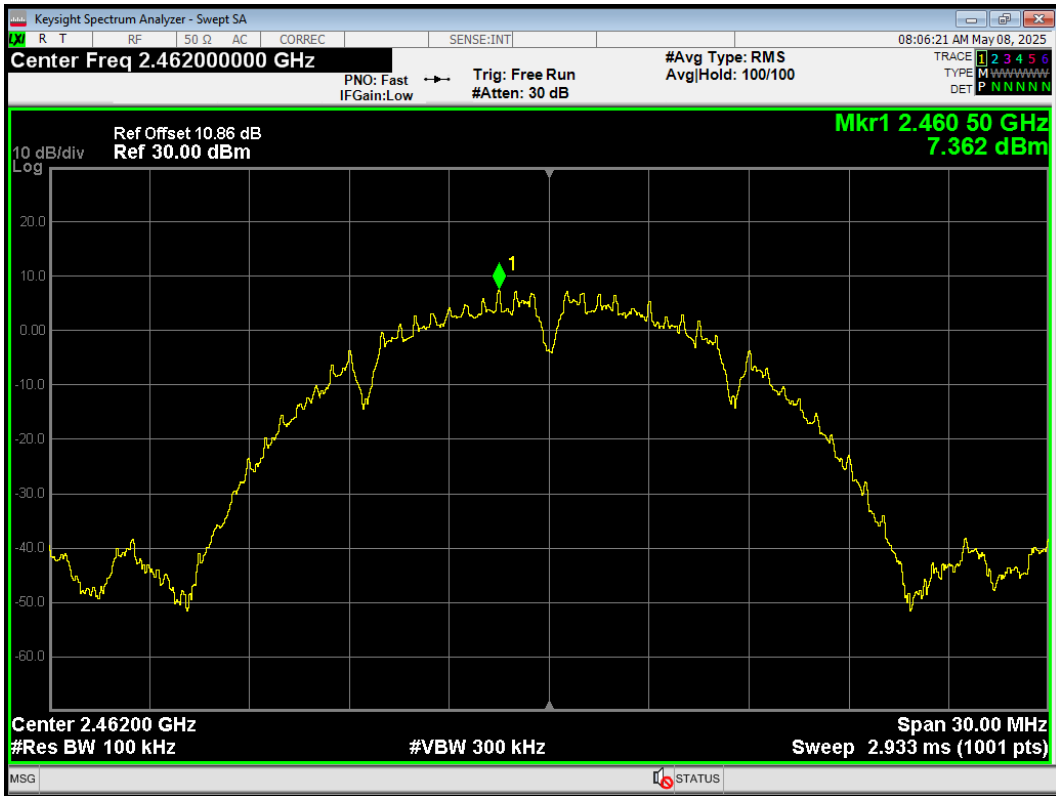

Tx. Spurious 802.11b 2462MHz Emission

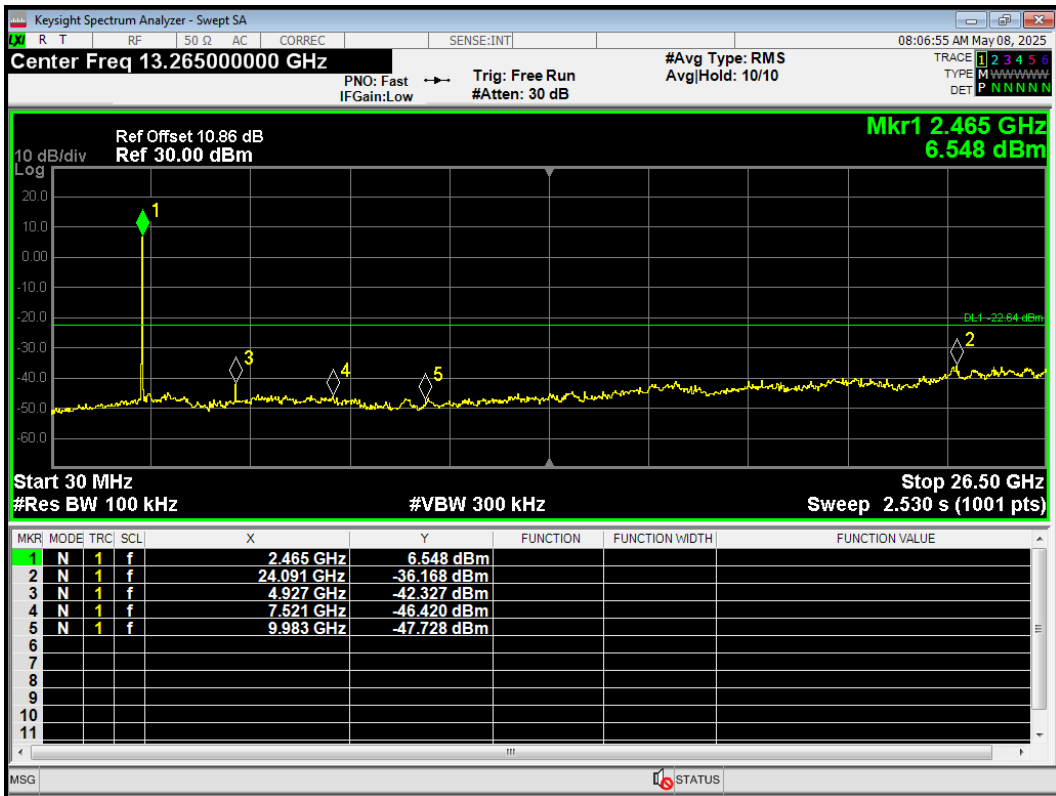

Tx. Spurious 802.11g 2412MHz Ref

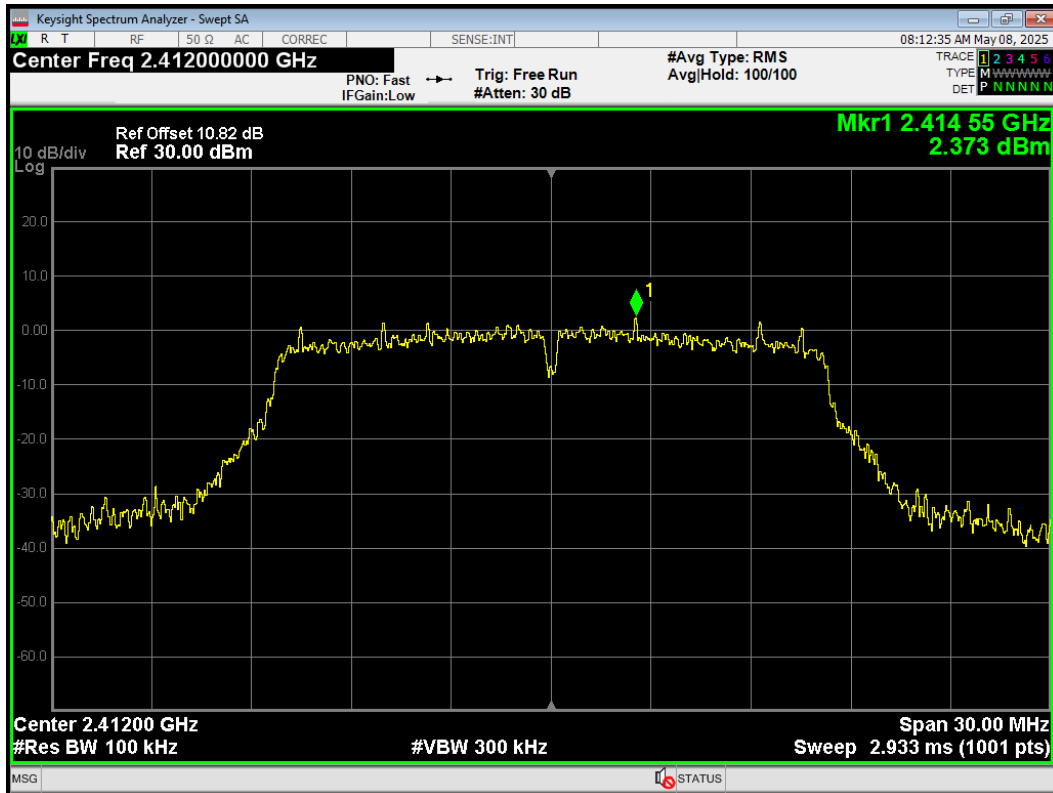

Tx. Spurious 802.11g 2412MHz Emission

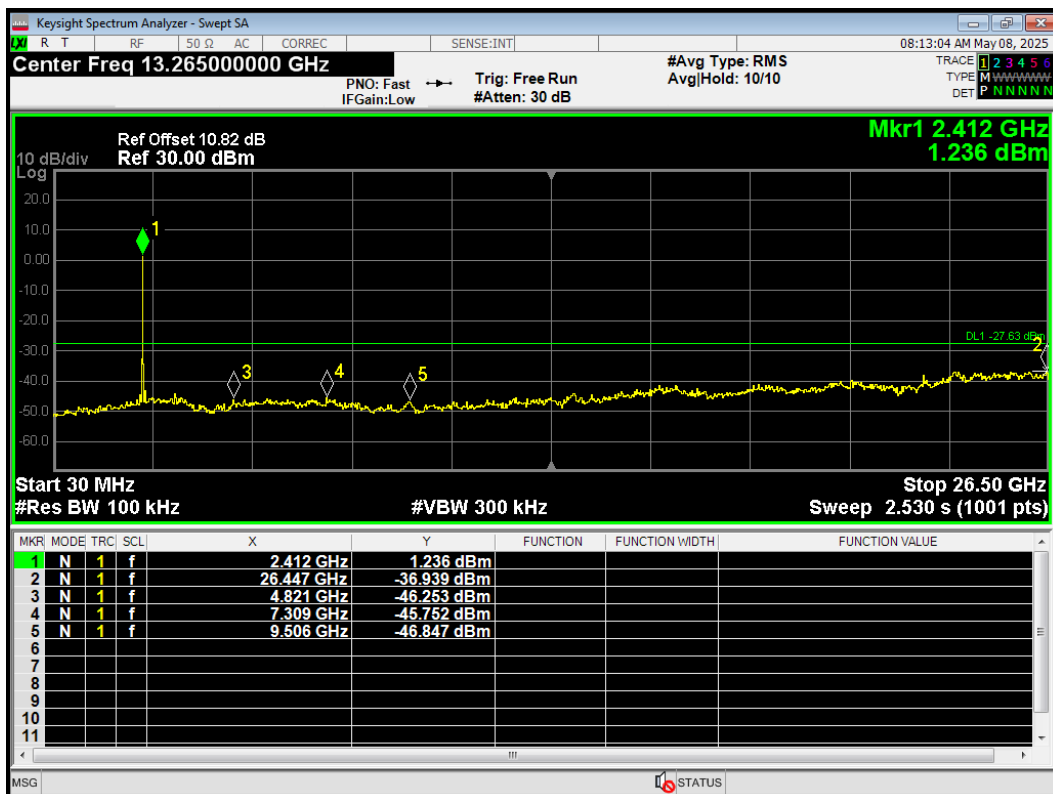

Tx. Spurious 802.11g 2437MHz Ref

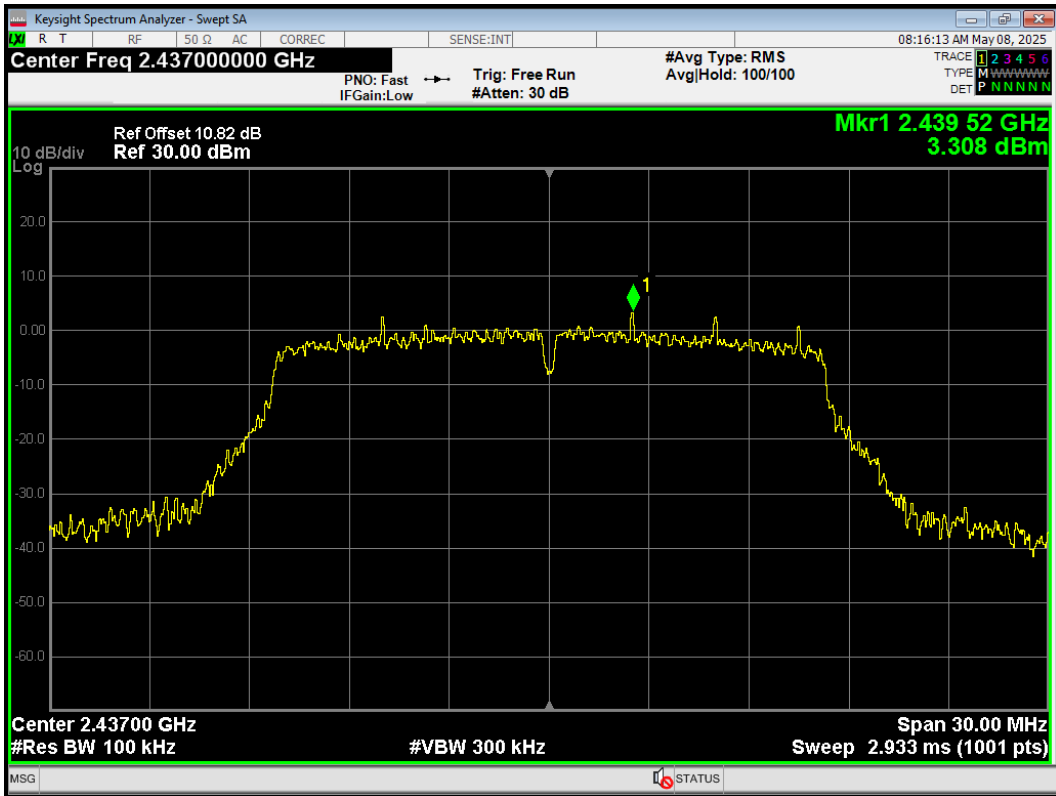

Tx. Spurious 802.11g 2437MHz Emission

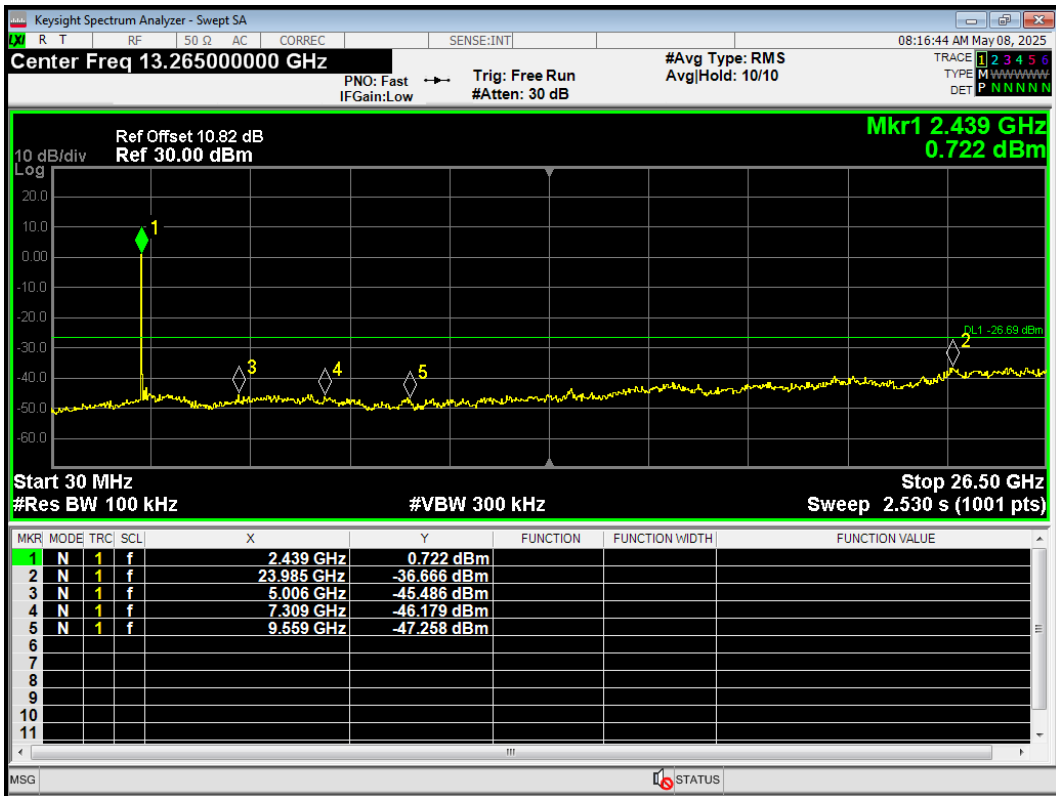

Tx. Spurious 802.11g 2462MHz Ref

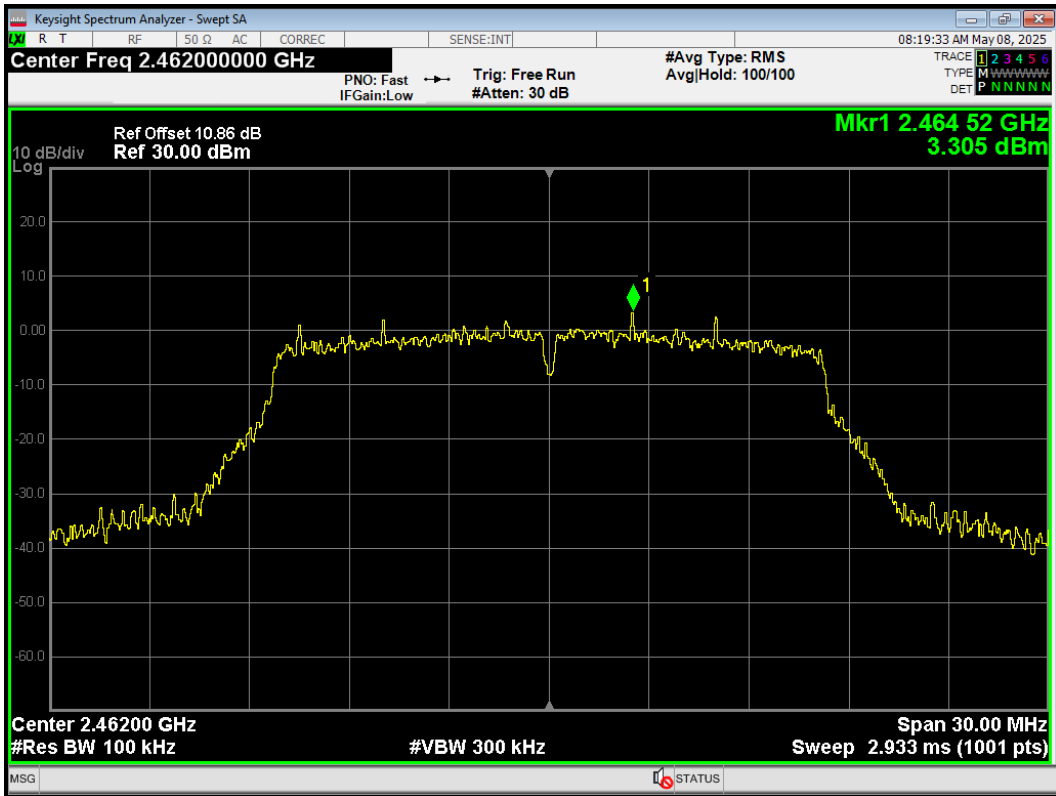

Tx. Spurious 802.11g 2462MHz Emission

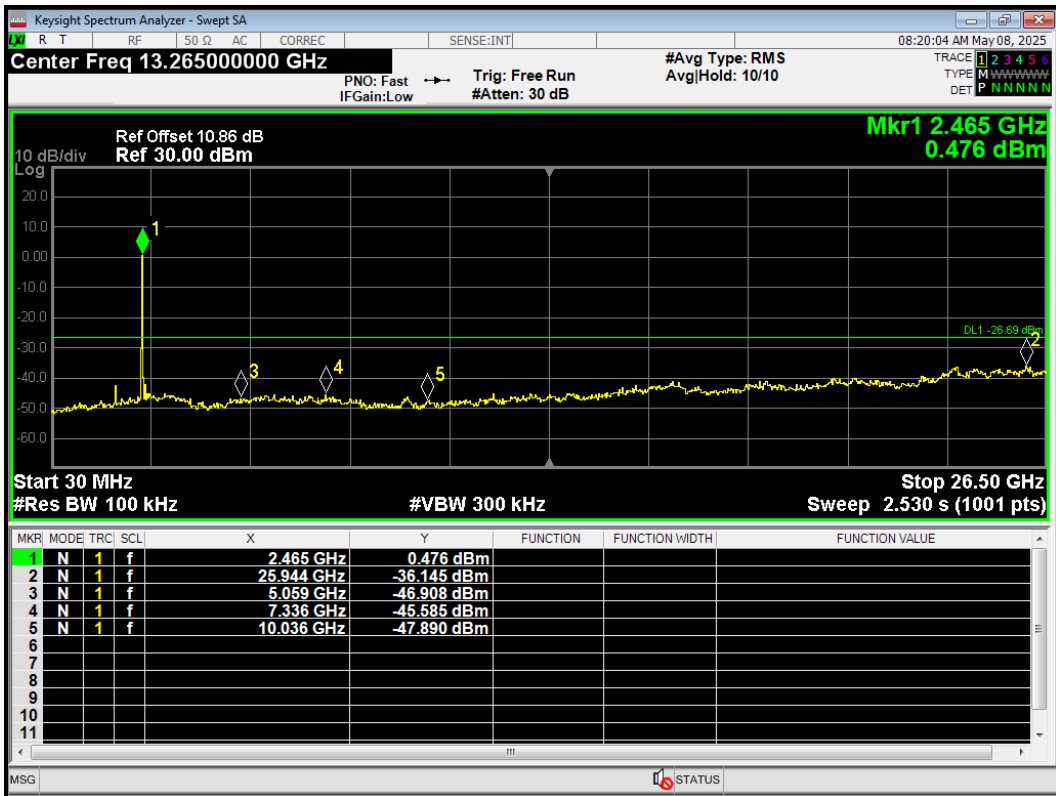

Tx. Spurious 802.11n(HT20) 2412MHz Ref

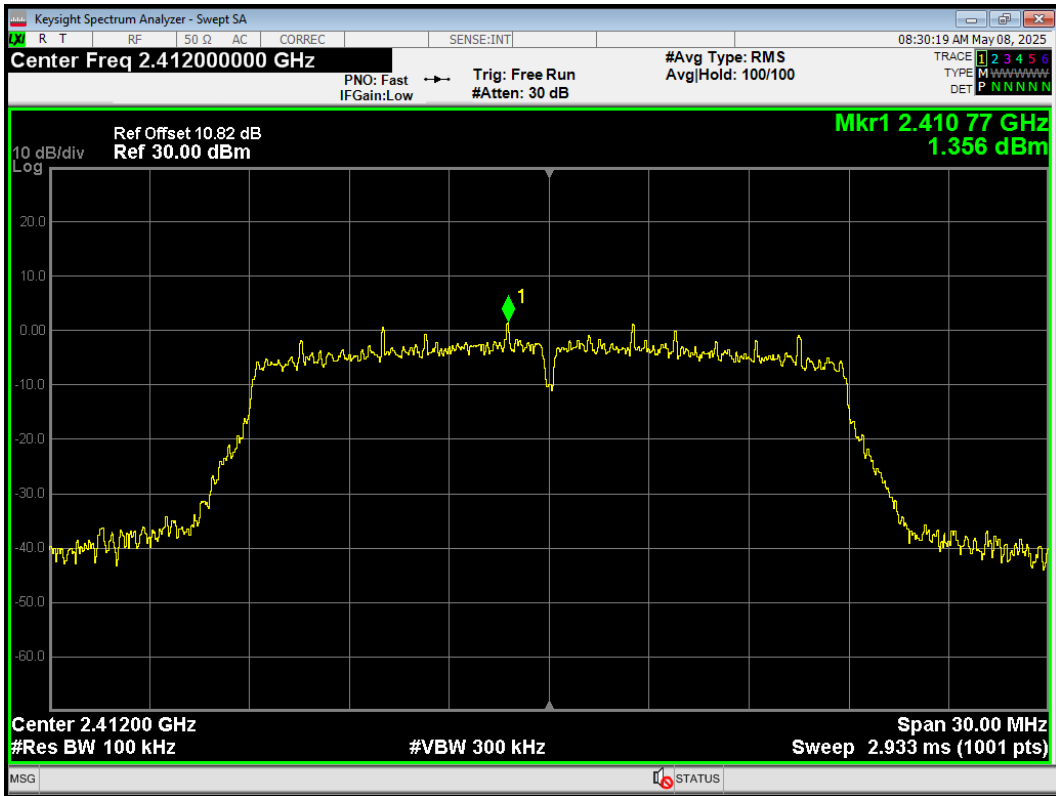

Tx. Spurious 802.11n(HT20) 2412MHz Emission

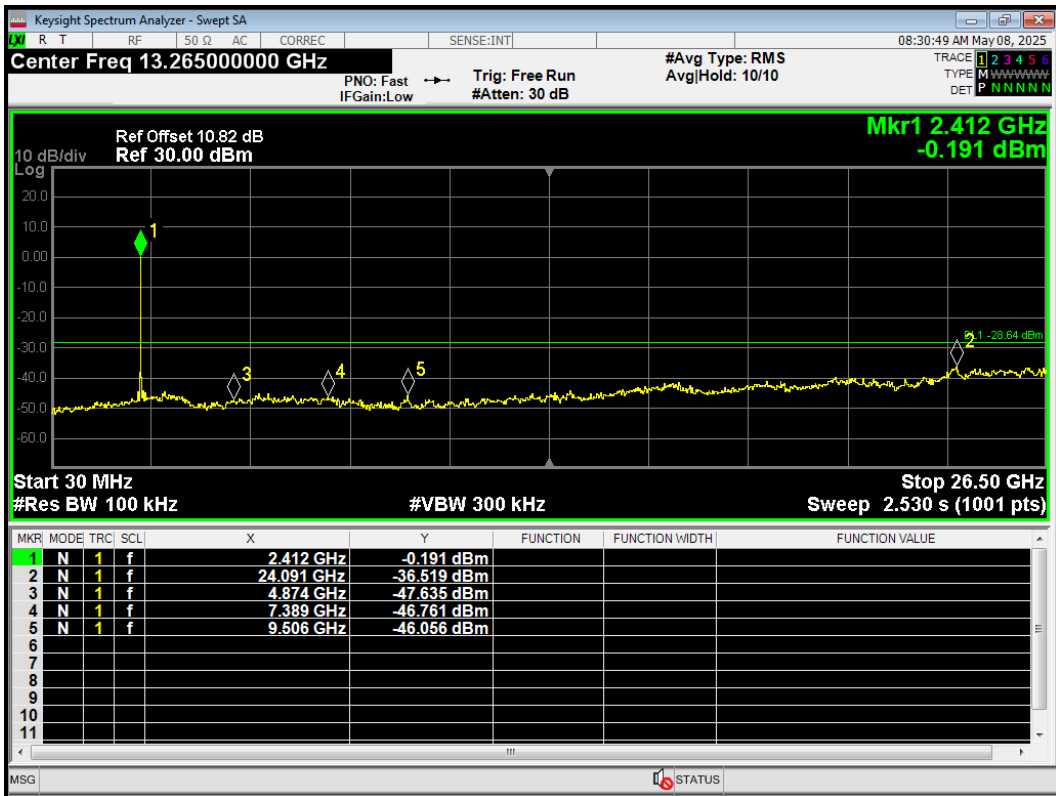

Tx. Spurious 802.11n(HT20) 2437MHz Ref

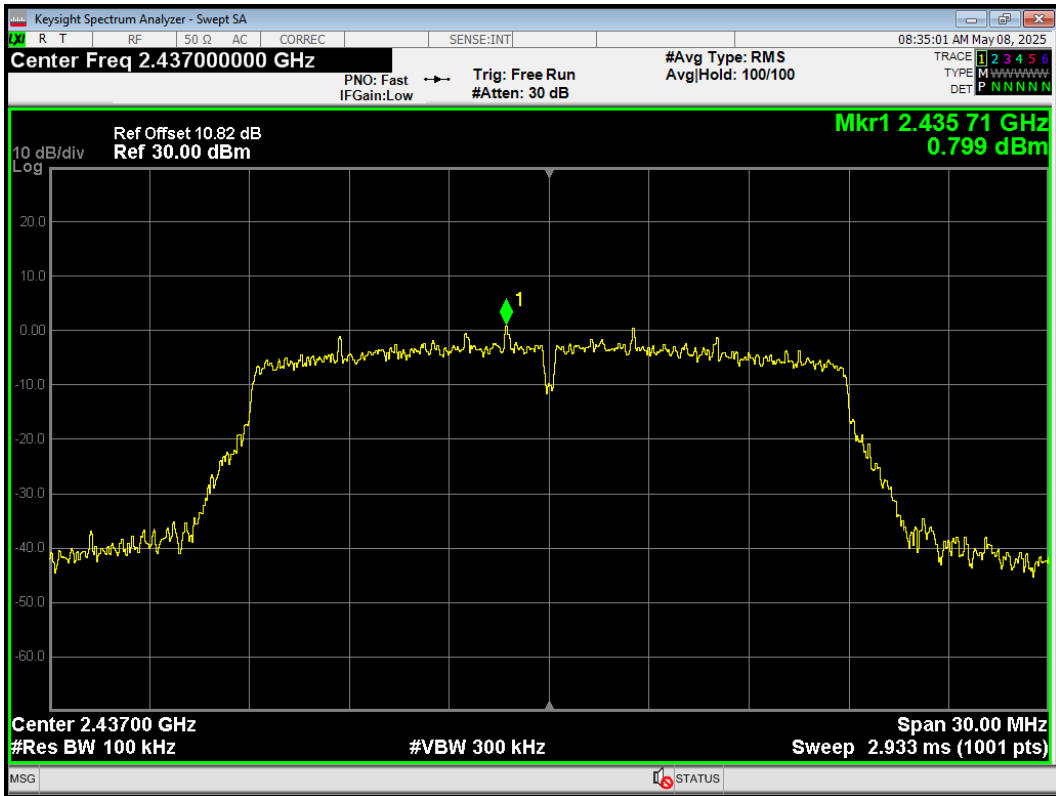

Tx. Spurious 802.11n(HT20) 2437MHz Emission

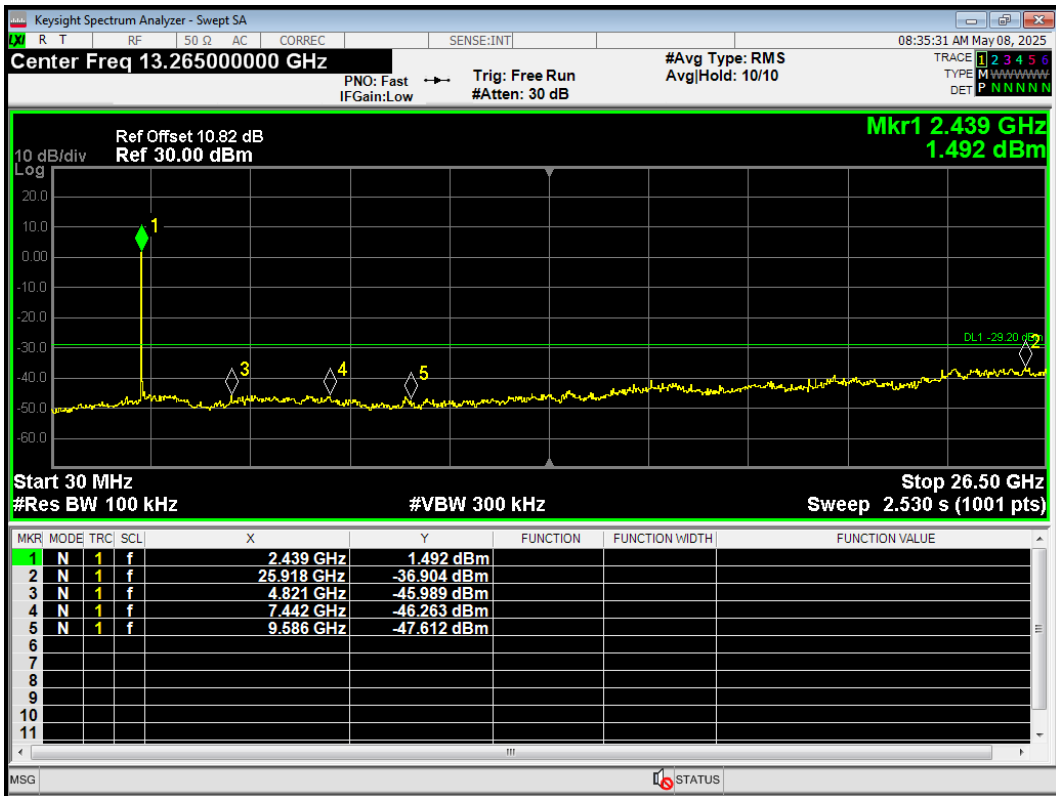

Tx. Spurious 802.11n(HT20) 2462MHz Ref

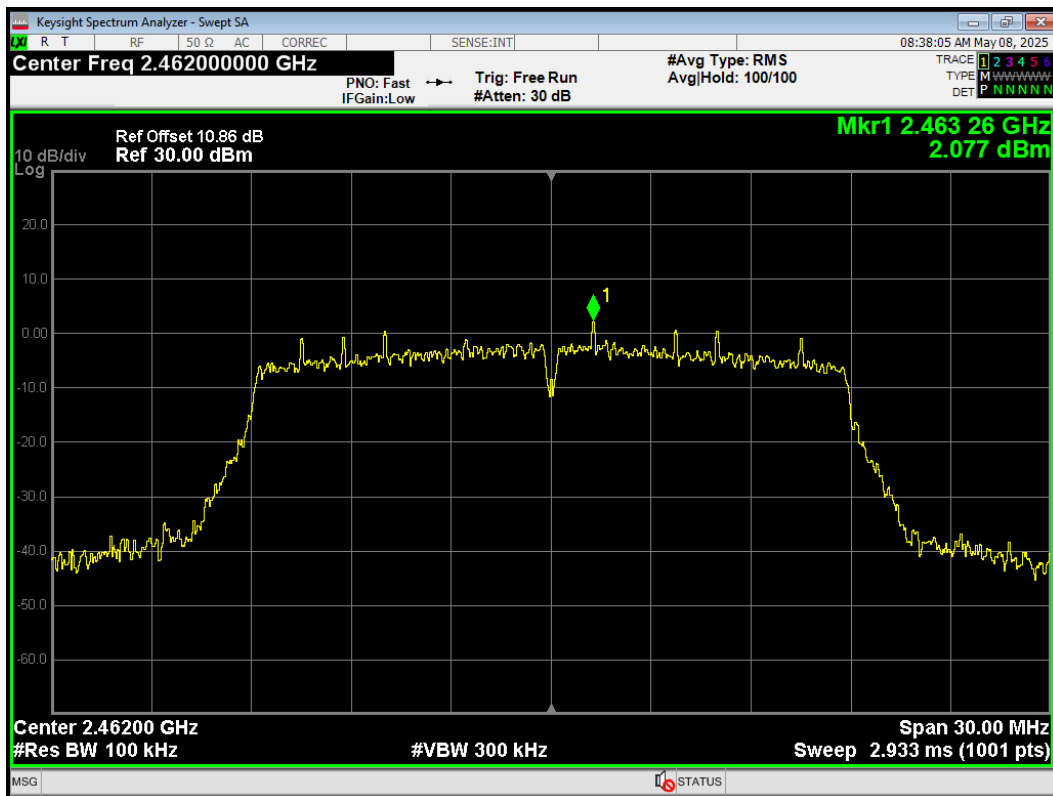

Tx. Spurious 802.11n(HT20) 2462MHz Emission

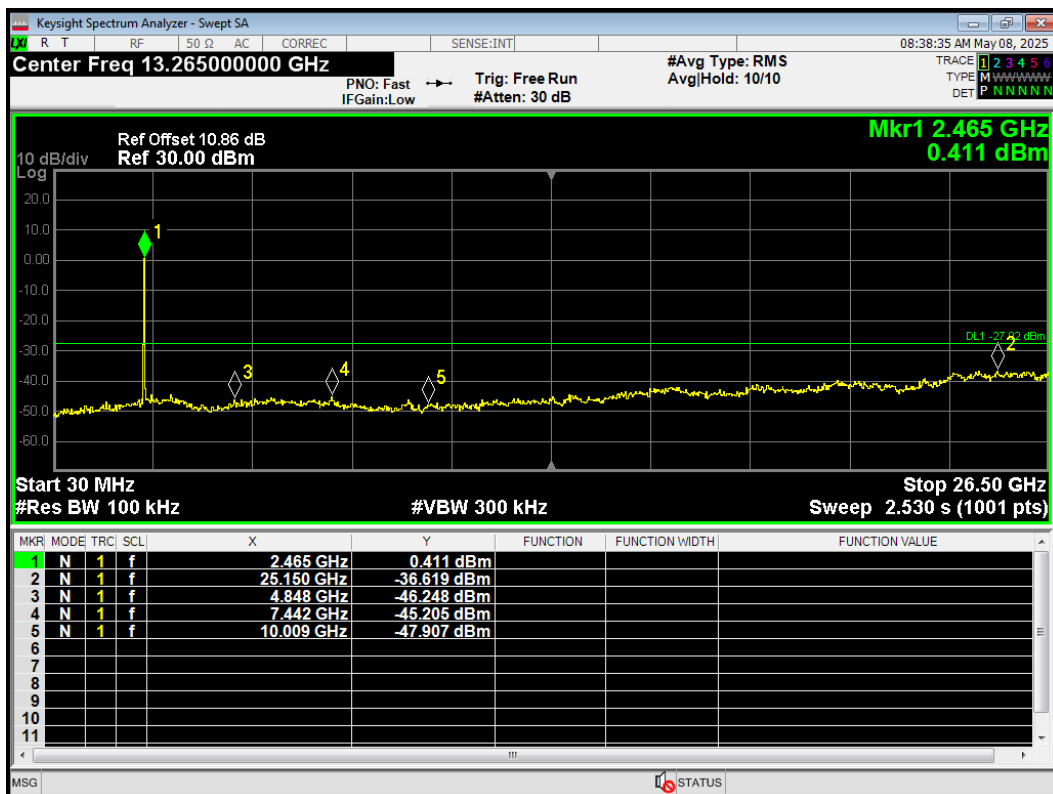

Tx. Spurious 802.11n(HT40) 2422MHz Ref

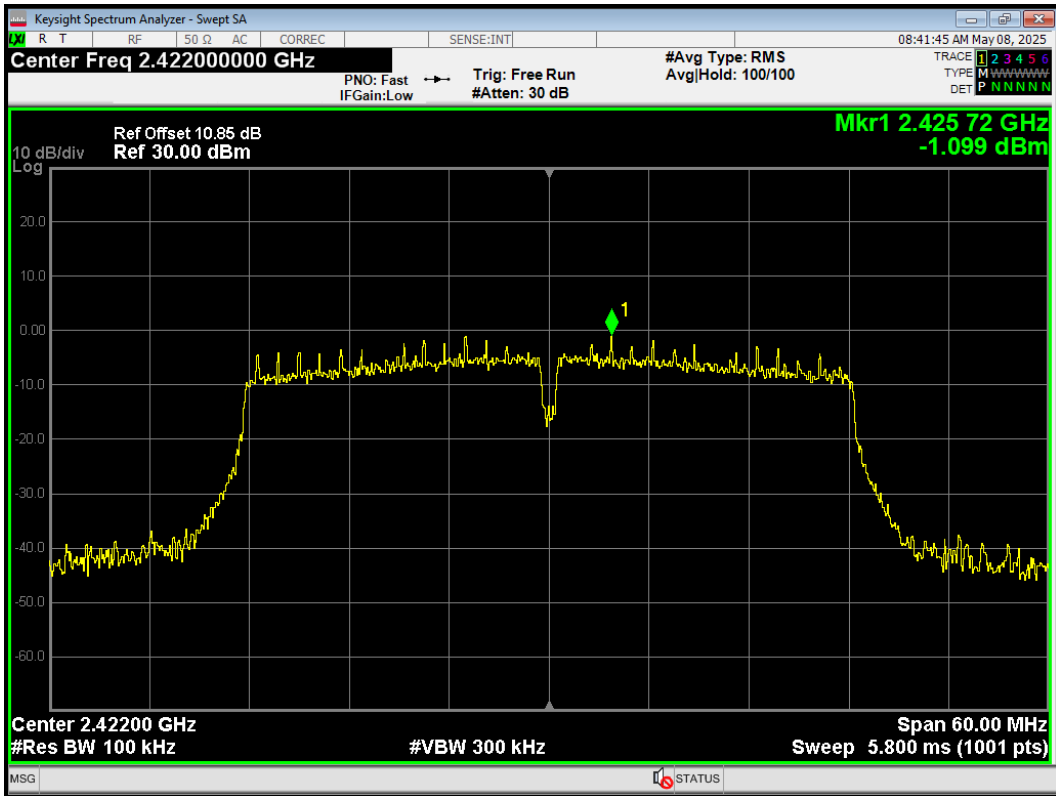

Tx. Spurious 802.11n(HT40) 2422MHz Emission

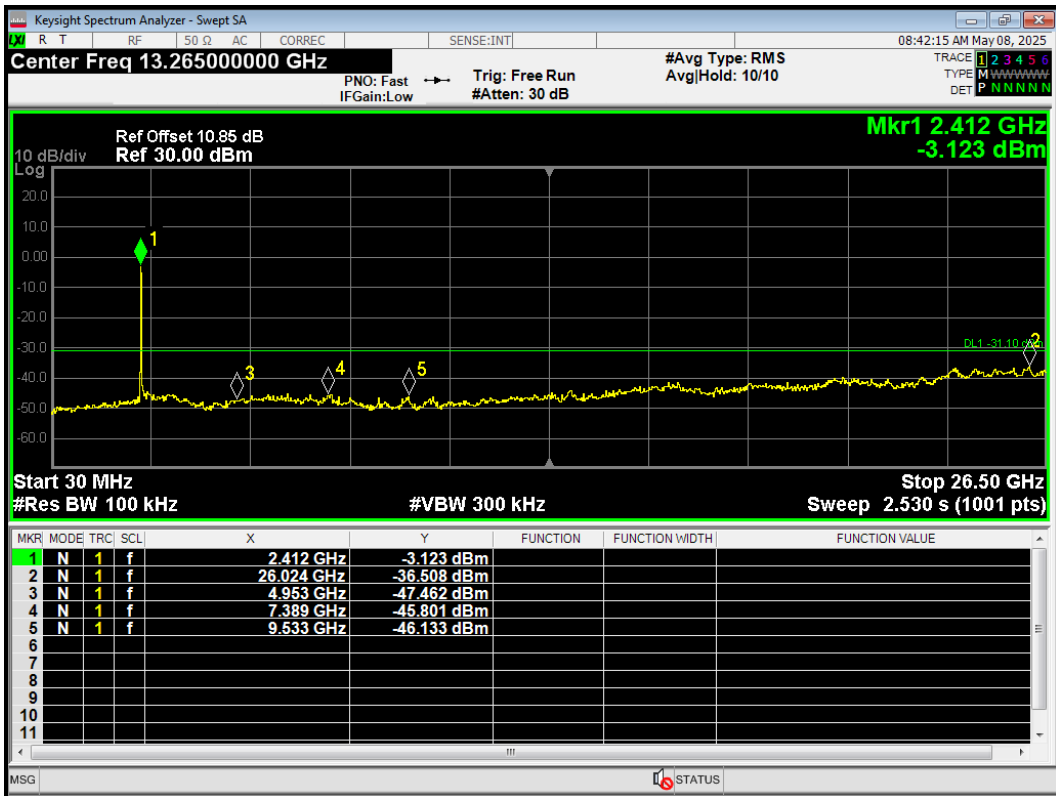

Tx. Spurious 802.11n(HT40) 2437MHz Ref

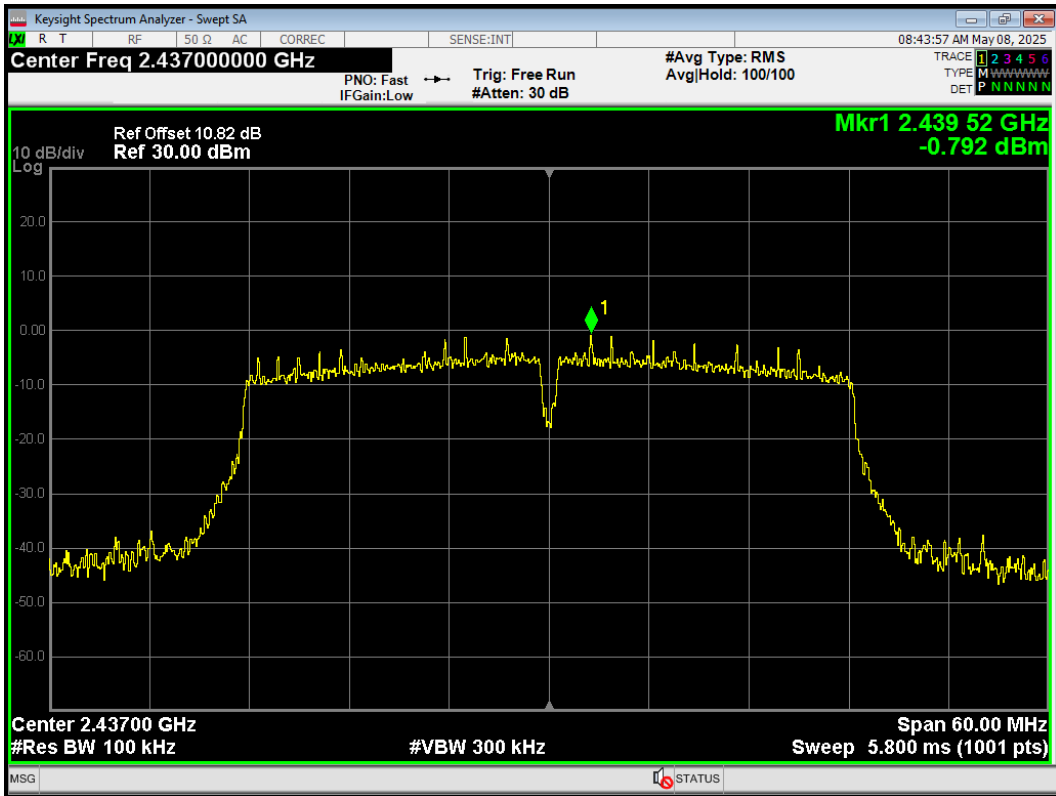

Tx. Spurious 802.11n(HT40) 2437MHz Emission

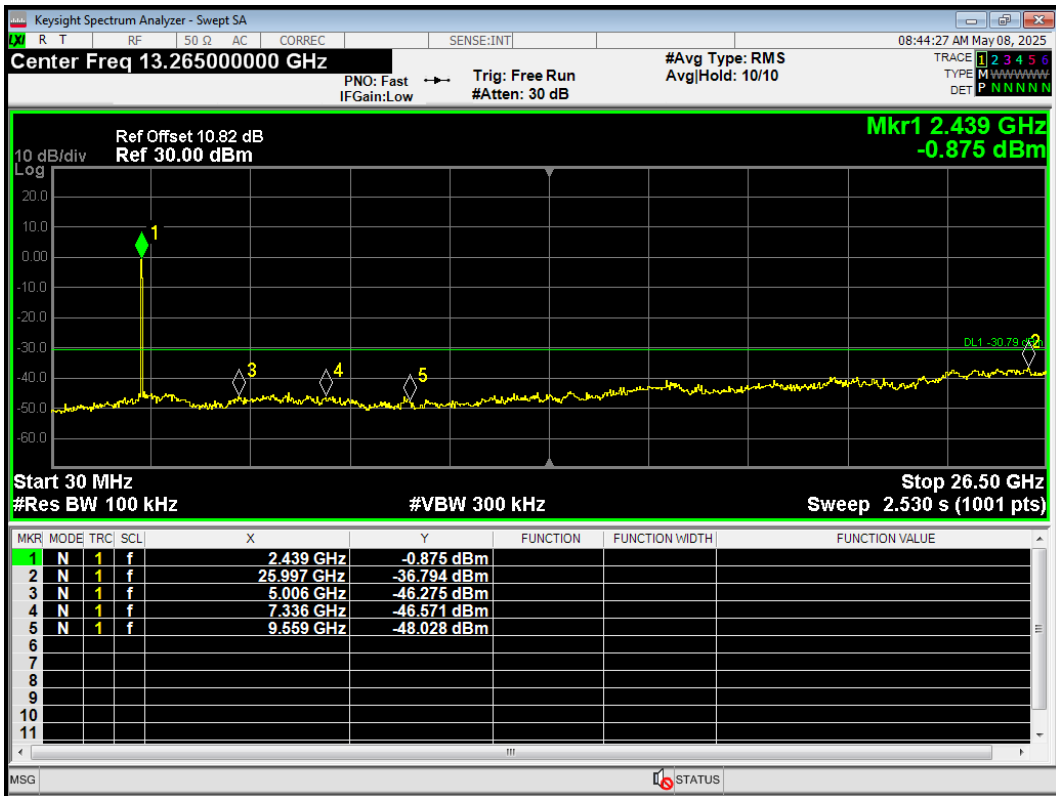

Tx. Spurious 802.11n(HT40) 2452MHz Ref

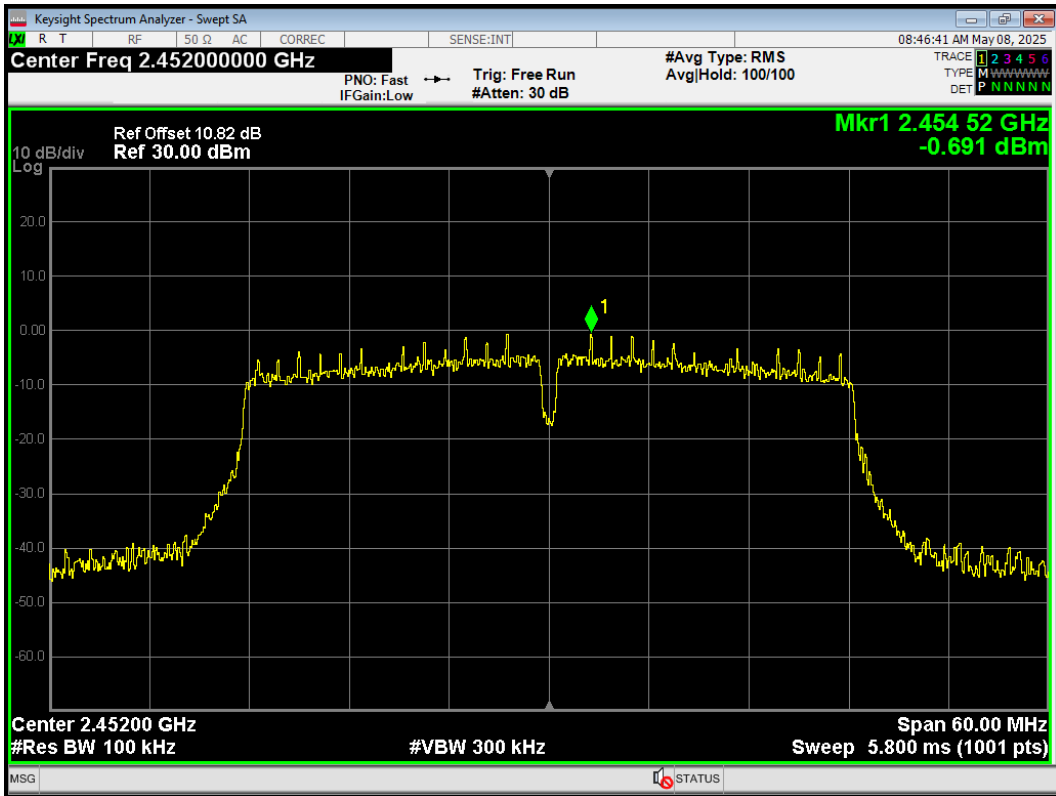

Tx. Spurious 802.11n(HT40) 2452MHz Emission

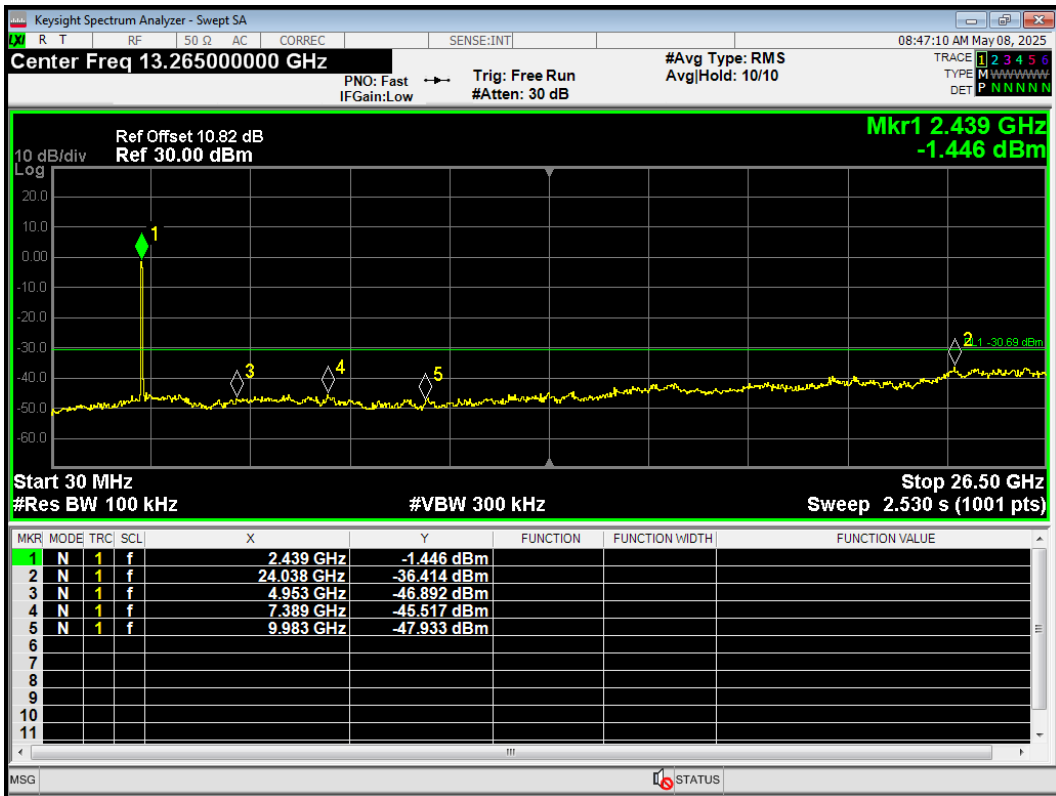

Tx. Spurious BLE (1M) 2402MHz Ref

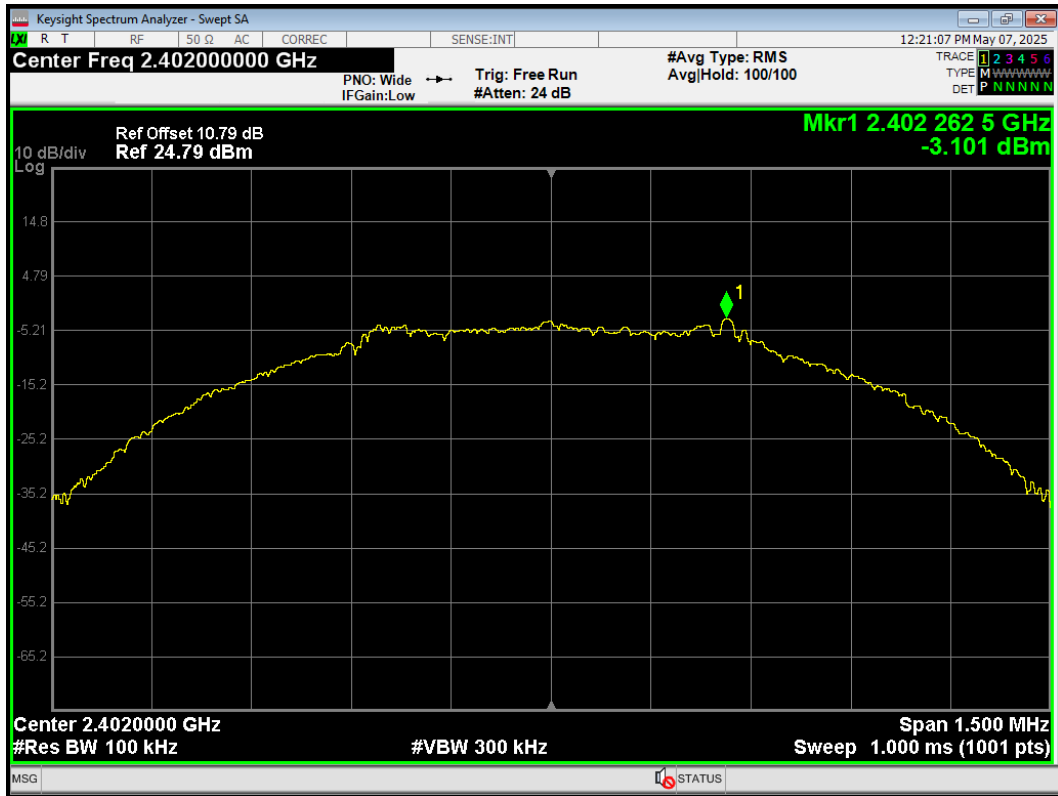

Tx. Spurious BLE (1M) 2402MHz Emission

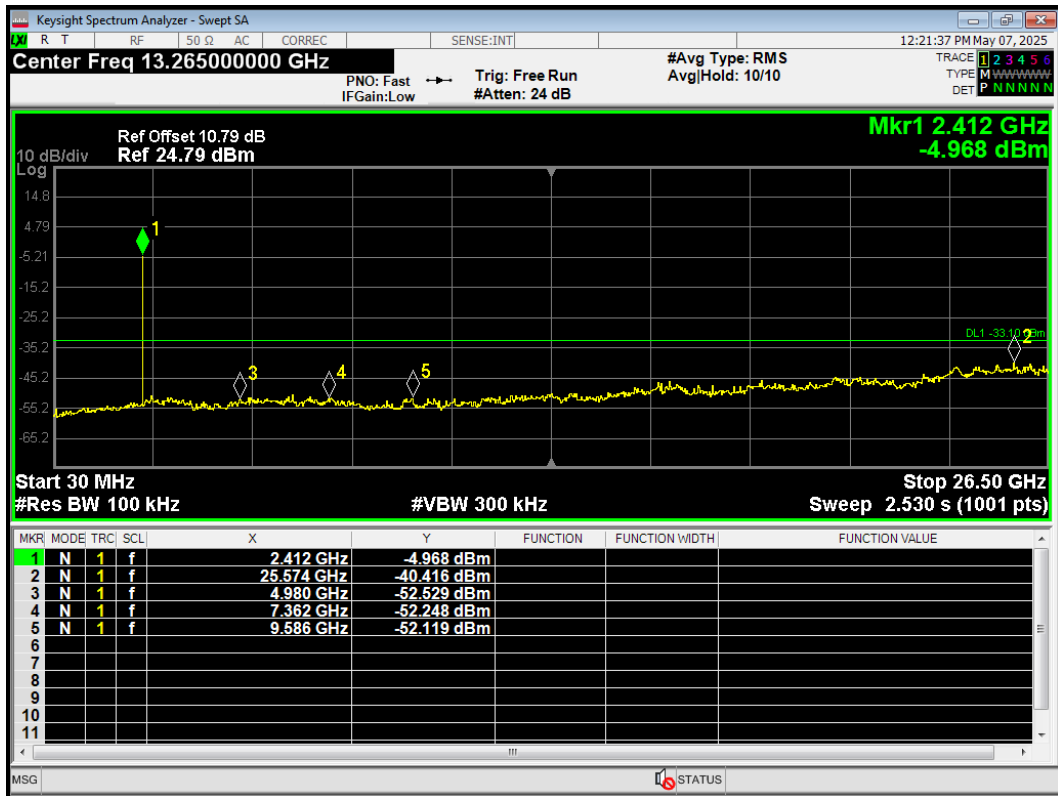

Tx. Spurious BLE (1M) 2440MHz Ref

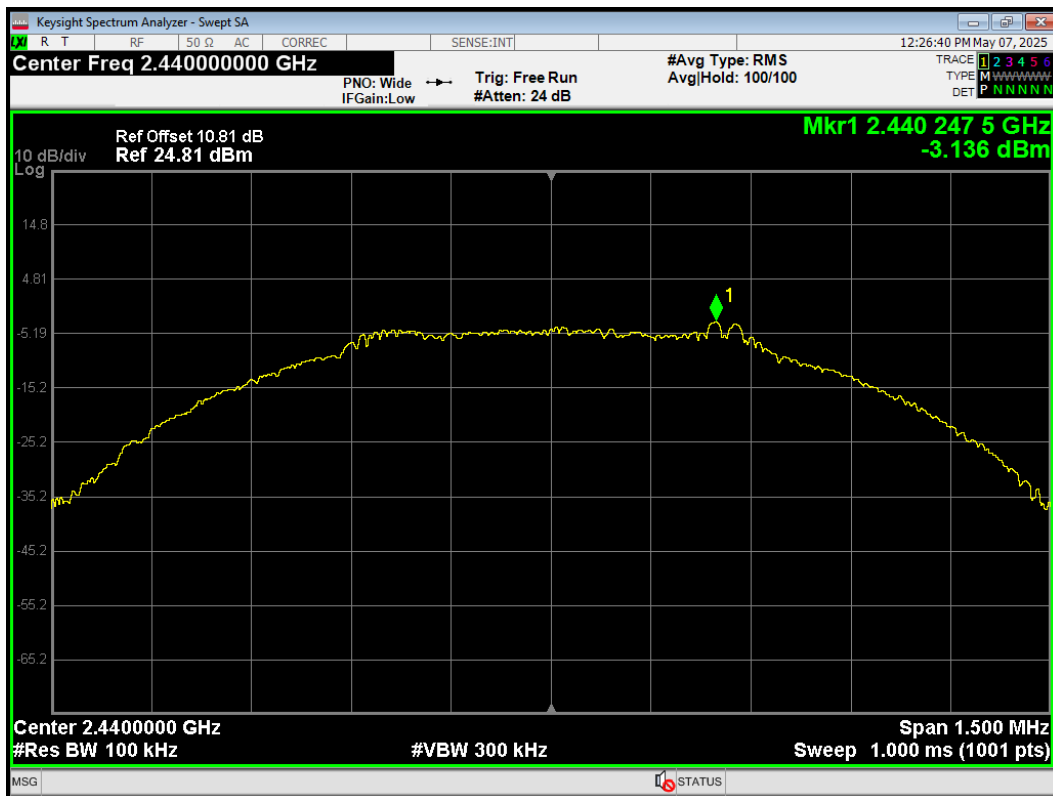

Tx. Spurious BLE (1M) 2440MHz Emission

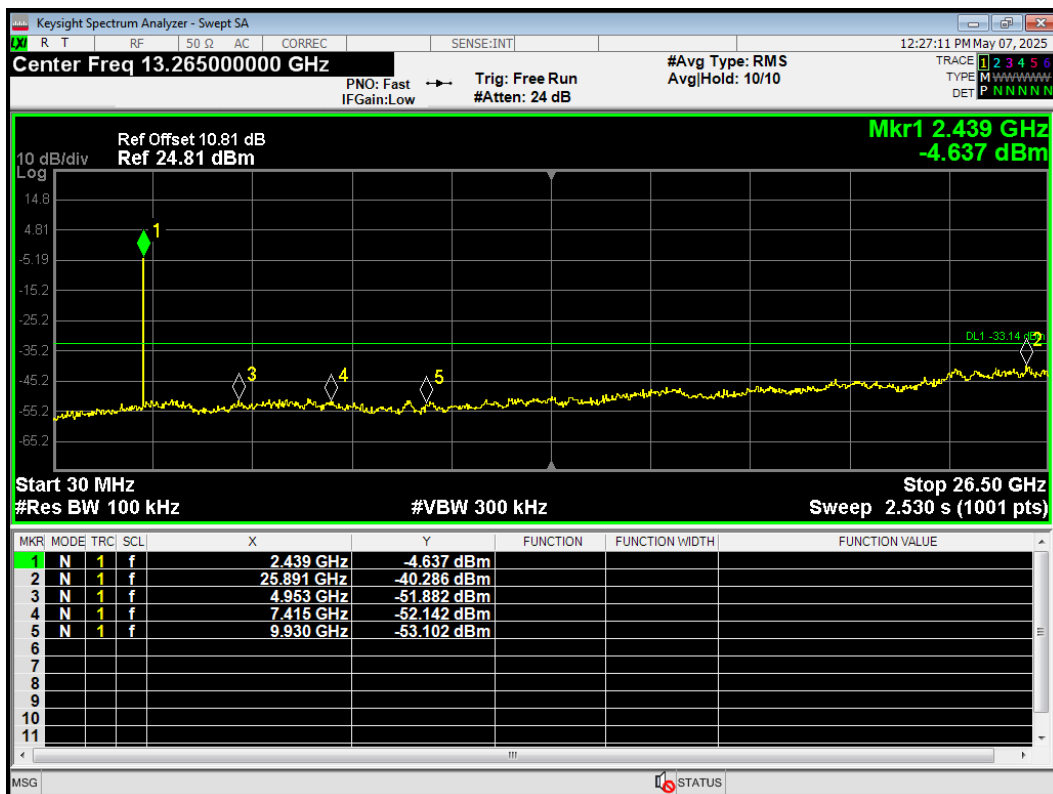

Tx. Spurious BLE (1M) 2480MHz Ref

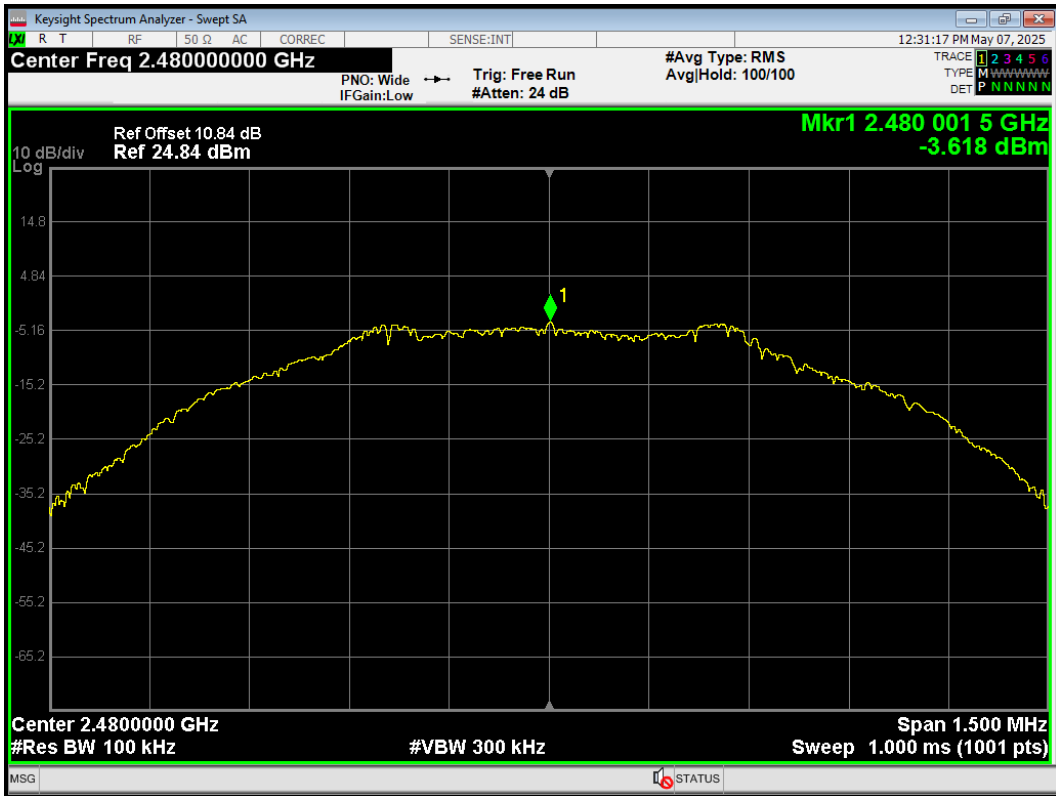

Tx. Spurious BLE (1M) 2480MHz Emission

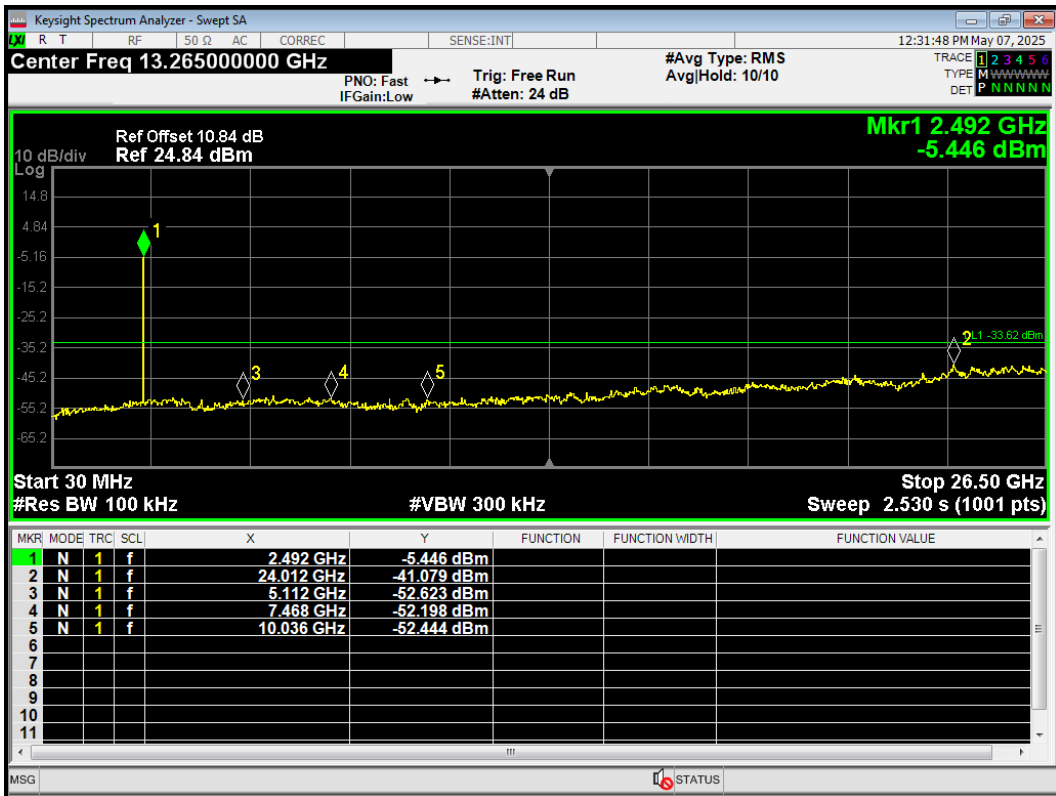

Tx. Spurious BLE (2M) 2404MHz Ref

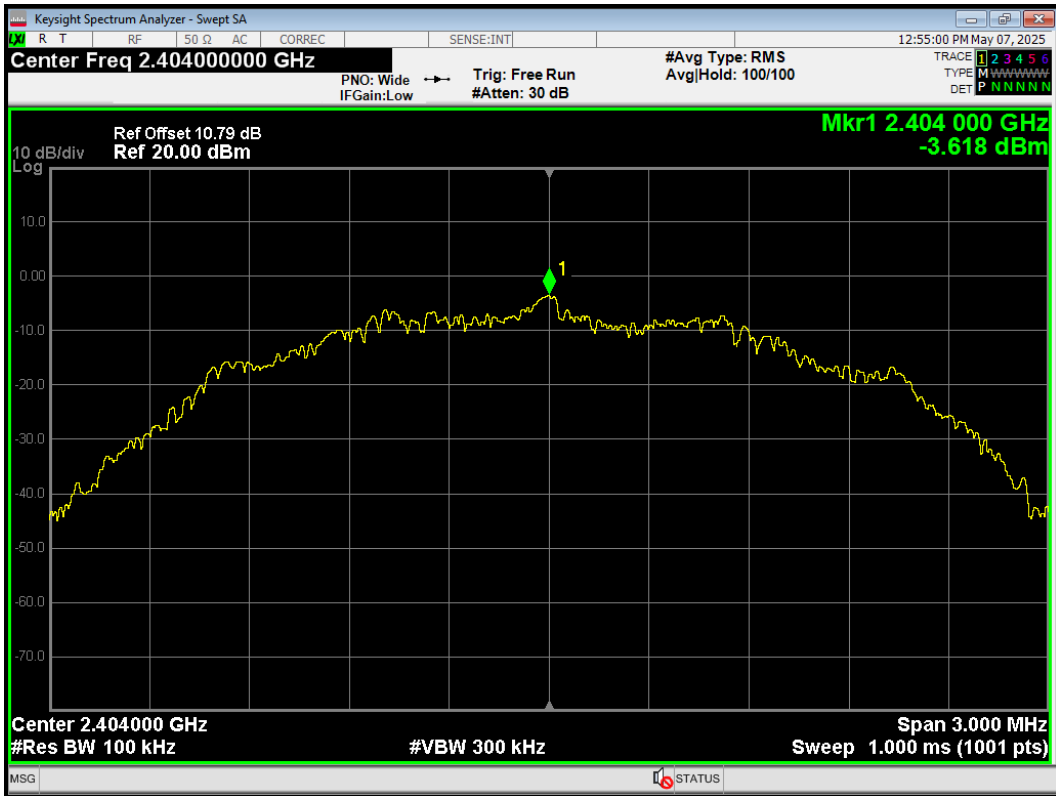

Tx. Spurious BLE (2M) 2404MHz Emission

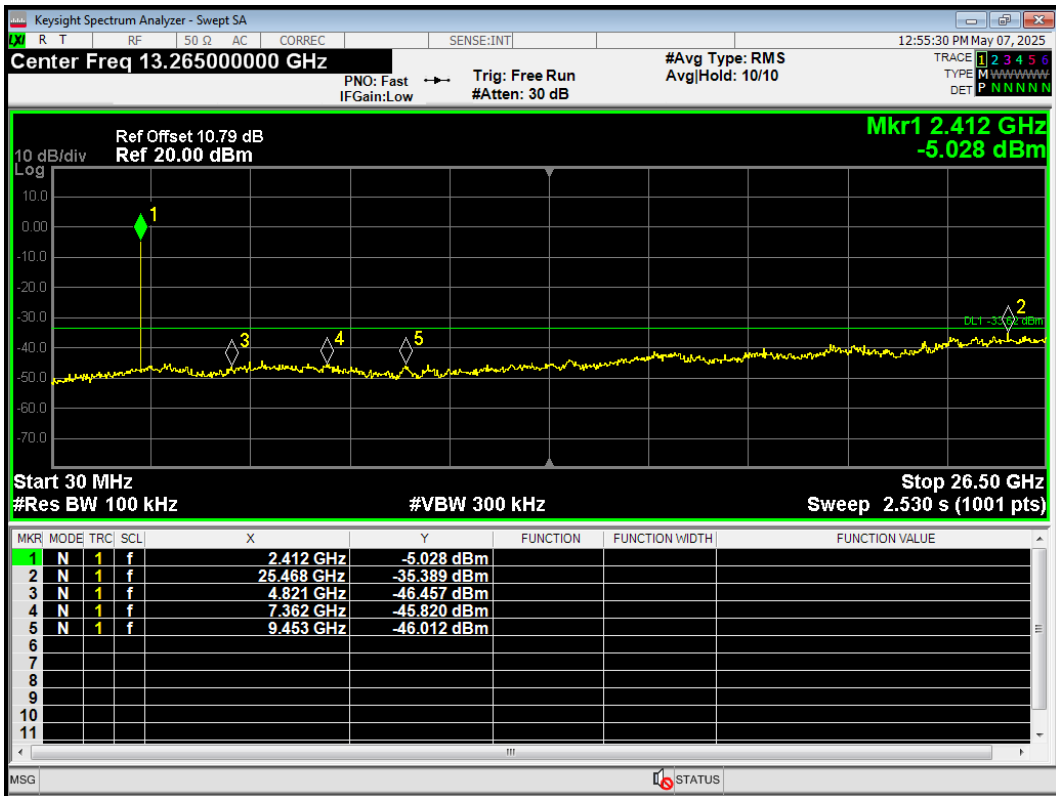

Tx. Spurious BLE (2M) 2440MHz Ref

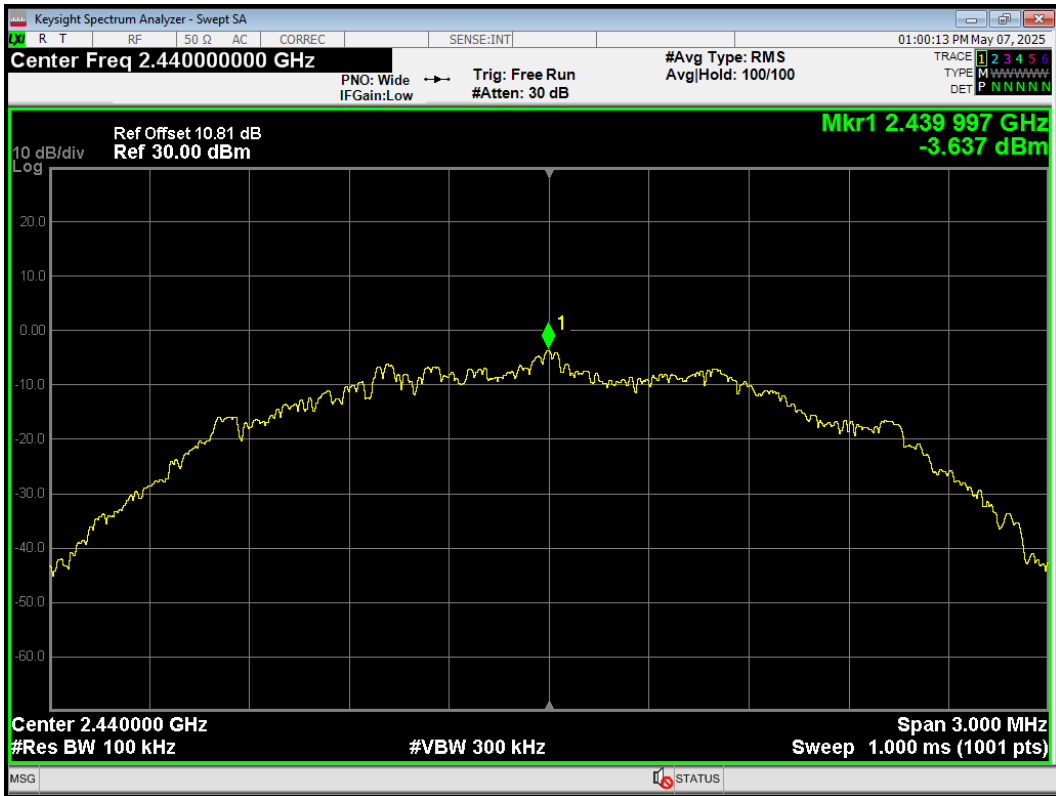

Tx. Spurious BLE (2M) 2440MHz Emission

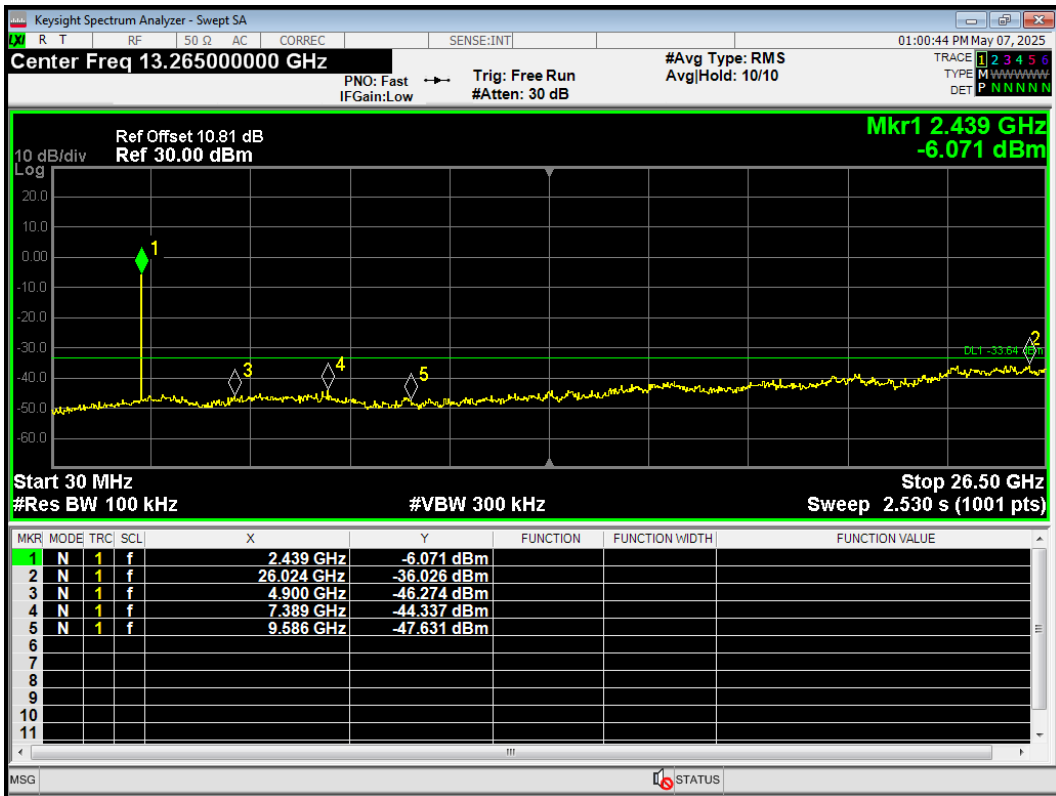

Tx. Spurious BLE (2M) 2478MHz Ref

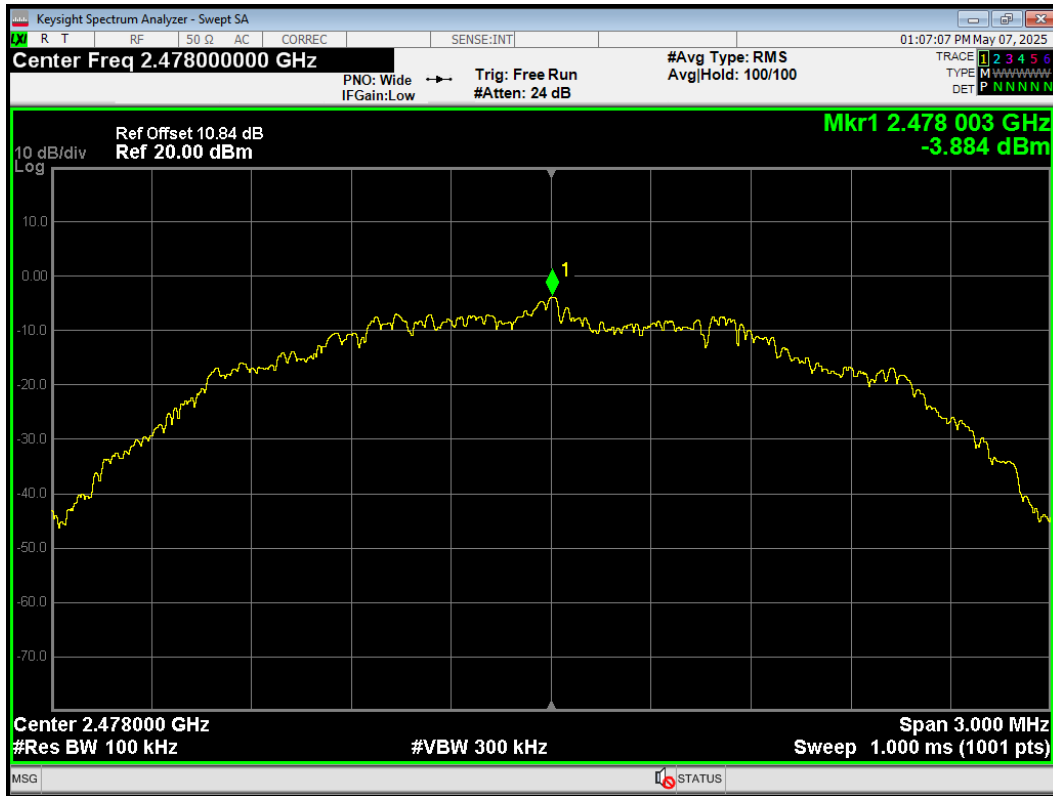

Tx. Spurious BLE (2M) 2478MHz Emission

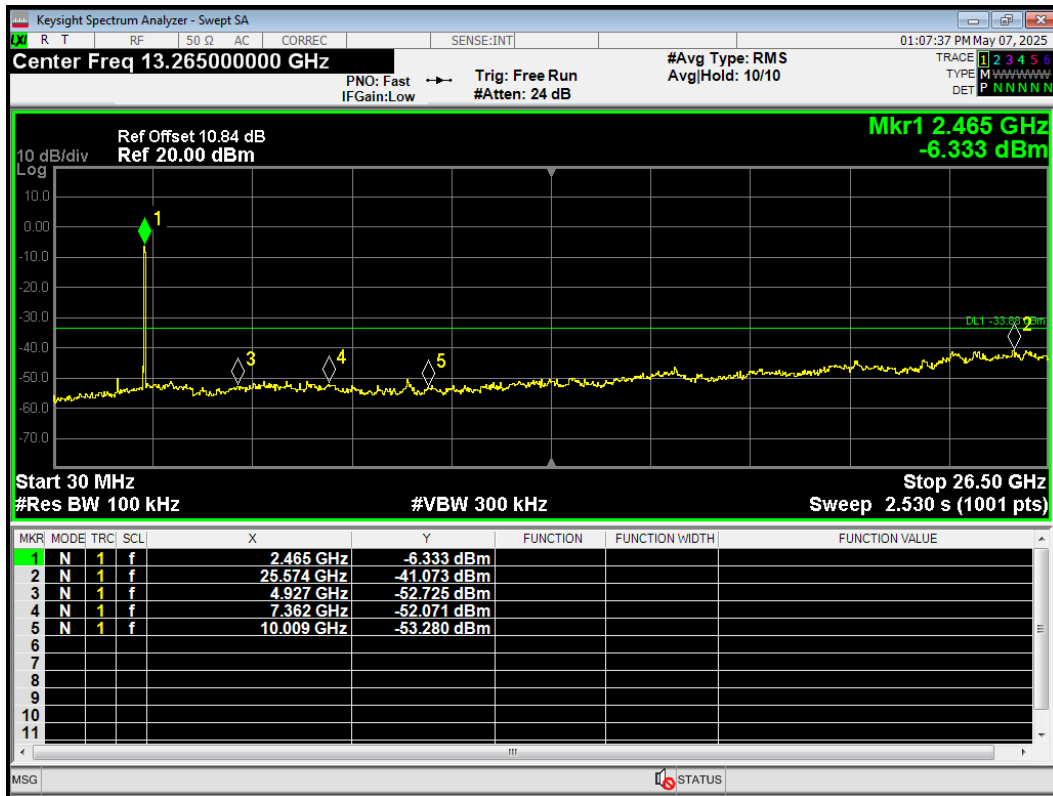

5.6. Unwanted Emission

Ambient Condition

Temperature	Relative humidity
15°C ~ 35°C	20% ~ 80%

Method of Measurement

The test set-up was made in accordance to the general provisions of ANSI C63.10.

The Equipment Under Test (EUT) was set up on a non-conductive table in the semi-anechoic chamber. The test was performed at the distance of 3 m between the EUT and the receiving antenna.

The turntable shall be rotated from 0 to 360 degrees for detecting the maximum of radiated spurious signal level. The measurements shall be repeated with orthogonal polarization of the test antenna. The data of cable loss and antenna factor has been calibrated in full testing frequency range before the testing. Sweep the Restricted Band and the emissions less than 20 dB below the permissible value are reported.

The radiated emissions measurements were made in a typical installation configuration.

Sweep the whole frequency band through the range from 9 kHz to the 10th harmonic of the carrier, and the emissions less than 20 dB below the permissible value are reported.

This method refer to ANSI C63.10.

The procedure for peak unwanted emissions measurements above 1000 MHz is as follows:

Set the spectrum analyzer in the following:

9kHz~150 kHz

RBW=200Hz, VBW=1kHz/ Sweep=AUTO

150 kHz~30MHz

RBW=9kHz, VBW=30kHz,/ Sweep=AUTO

Below 1GHz

RBW=100kHz / VBW=300kHz / Sweep=AUTO

a) Peak emission levels are measured by setting the instrument as follows:

Above 1GHz

PEAK: RBW=1MHz VBW=3MHz/ Sweep=AUTO

b) Average emission levels are measured by setting the instrument as follows:

Above 1GHz

AVERAGE: RBW=1MHz / VBW=3MHz / Sweep=AUTO

c) Detector: The measurements employing a CISPR quasi-peak detector except for the frequency bands 9-90 kHz, 110-490 kHz and above 1000 MHz. Radiated emission limits in these three bands are based on measurements employing an average detector.

d) Averaging type = power (i.e., rms) (As an alternative, the detector and averaging type may be set for linear voltage averaging. Some instruments require linear display mode to use linear voltage averaging. Log or dB averaging shall not be used.)

e) Sweep time = auto.

f) Perform a trace average of at least 100 traces if the transmission is continuous. If the transmission is not continuous, then the number of traces shall be increased by a factor of $1 / D$, where D is the duty cycle. For example, with 50% duty cycle, at least 200 traces shall be averaged. (If a specific emission is demonstrated to be continuous—i.e., 100% duty cycle—then rather than turning ON and OFF with the transmit cycle, at least 100 traces shall be averaged.)

g) If tests are performed with the EUT transmitting at a duty cycle less than 98%, then a correction factor shall be added to the measurement results prior to comparing with the emission limit, to compute the emission level that would have been measured had the test been performed at 100% duty cycle. The correction factor is computed as follows:

1) If power averaging (rms) mode was used in the preceding step e), then the correction factor is $[10 \log (1 / D)]$, where D is the duty cycle. For example, if the transmit duty cycle was 50%, then 3 dB shall be added to the measured emission levels.

2) If linear voltage averaging mode was used in the preceding step e), then the correction factor is $[20 \log (1 / D)]$, where D is the duty cycle. For example, if the transmit duty cycle was 50%, then 6 dB shall be added to the measured emission levels.

3) If a specific emission is demonstrated to be continuous (100% duty cycle) rather than turning ON and OFF with the transmit cycle, then no duty cycle correction is required for that emission.

The test is in transmitting mode.

Test Setup

9kHz~ 30MHz

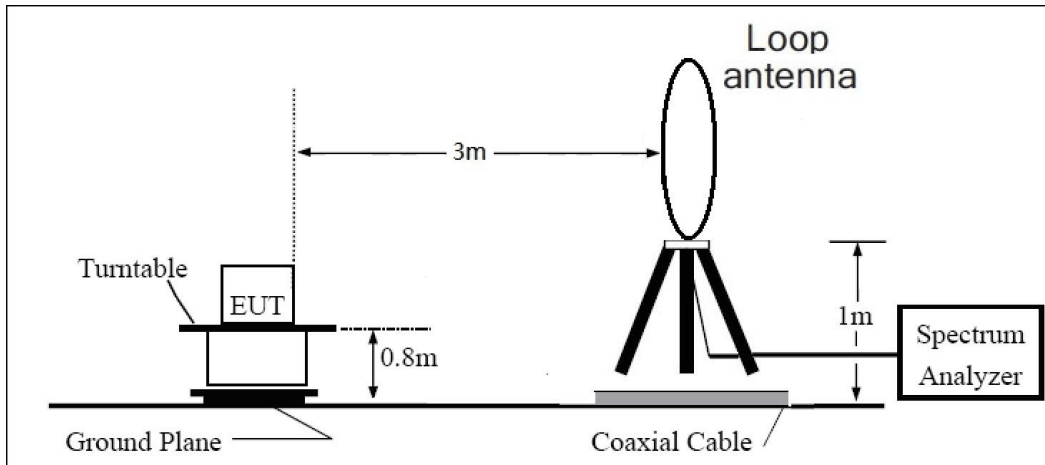

30MHz~ 1GHz

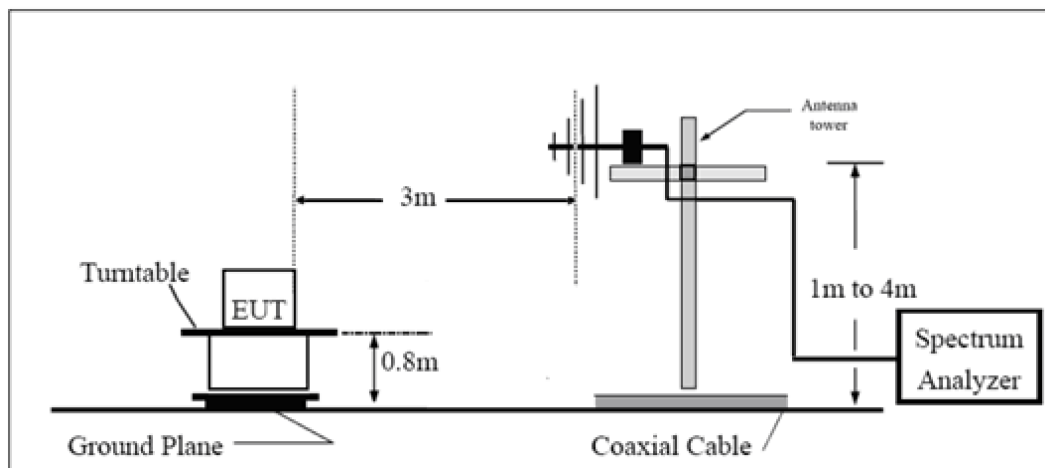

Above 1GHz

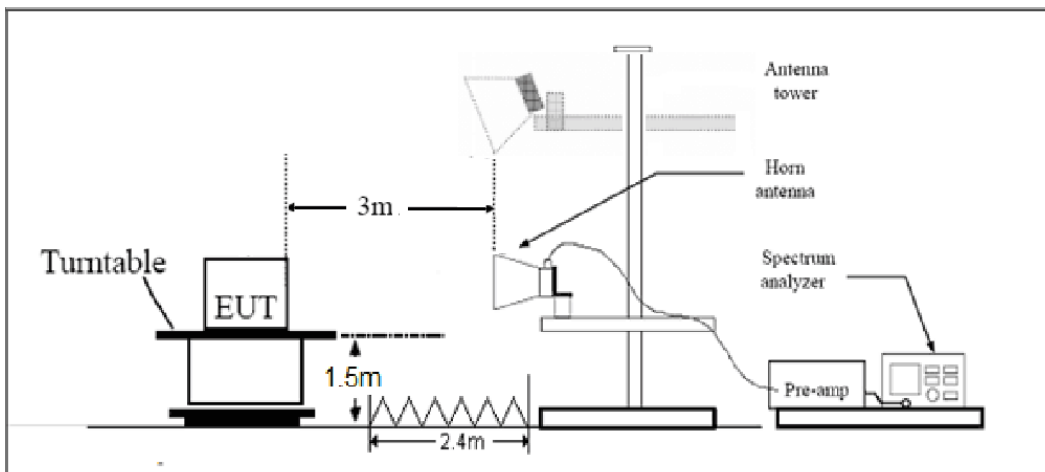

Note: Area side:2.4mX3.6m

Limits

Rule Part 15.247(d) specifies that “In addition, radiated emissions which fall in the restricted bands, as defined in § 15.205(a), must also comply with the radiated emission limits specified in § 15.209(a) (see § 15.205(c)).”

Limit in restricted band

Frequency of emission (MHz)	Field strength($\mu\text{V}/\text{m}$)	Field strength($\text{dB}\mu\text{V}/\text{m}$)
0.009–0.490	2400/F(kHz)	/
0.490–1.705	24000/F(kHz)	/
1.705–30.0	30	/
30-88	100	40
88-216	150	43.5
216-960	200	46
Above960	500	54

§15.35(b)

There is also a limit on the radio frequency emissions, as measured using instrumentation with a peak detector function, corresponding to 20 dB above the maximum permitted average limit.

Peak Limit=74 $\text{dB}\mu\text{V}/\text{m}$

Average Limit=54 $\text{dB}\mu\text{V}/\text{m}$

Spurious Radiated Emissions are permitted in any of the frequency bands listed below:

MHz	MHz	MHz	GHz
0.090-0.110	16.42-16.423	399.9-410	4.5-5.15
¹ 0.495-0.505	16.69475-16.69525	608-614	5.35-5.46
2.1735-2.1905	16.80425-16.80475	960-1240	7.25-7.75
4.125-4.128	25.5-25.67	1300-1427	8.025-8.5
4.17725-4.17775	37.5-38.25	1435-1626.5	9.0-9.2
4.20725-4.20775	73-74.6	1645.5-1646.5	9.3-9.5
6.215-6.218	74.8-75.2	1660-1710	10.6-12.7
6.26775-6.26825	108-121.94	1718.8-1722.2	13.25-13.4
6.31175-6.31225	123-138	2200-2300	14.47-14.5
8.291-8.294	149.9-150.05	2310-2390	15.35-16.2
8.362-8.366	156.52475-156.52525	2483.5-2500	17.7-21.4
8.37625-8.38675	156.7-156.9	2690-2900	22.01-23.12
8.41425-8.41475	162.0125-167.17	3260-3267	23.6-24.0
12.29-12.293	167.72-173.2	3332-3339	31.2-31.8
12.51975-12.52025	240-285	3345.8-3358	36.43-36.5
12.57675-12.57725	322-335.4	3600-4400	(²)
13.36-13.41			

Measurement Uncertainty

The assessed measurement uncertainty to ensure 95% confidence level for the normal distribution is with the coverage factor $k = 1.96$.

Frequency	Uncertainty
9kHz-30MHz	3.55 dB
30MHz-200MHz	4.17 dB
200MHz-1GHz	4.84 dB
1-18GHz	4.35 dB
18-26.5GHz	5.90 dB
26.5GHz~40GHz	5.92 dB

Test Results:

The following graphs display the maximum values of horizontal and vertical by software. Blue trace uses the peak detection, Green trace uses the average detection.

A symbol ($\text{dB}\mu\text{V}/\text{m}$) in the test plot below means ($\text{dB}\mu\text{V}/\text{m}$)

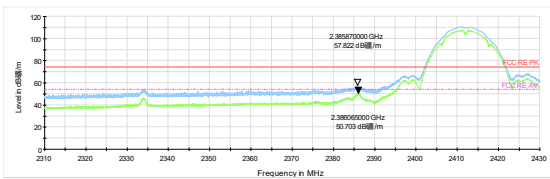

802.11b-Channel 1 Peak+ Average

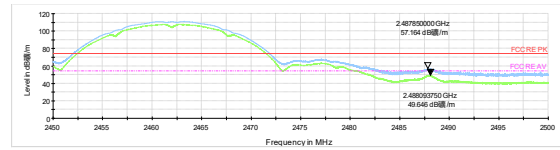

802.11b-Channel 11 Peak+ Average

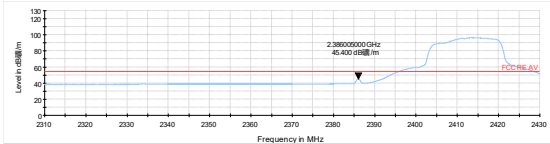

802.11g-Channel 1 Peak+ Average

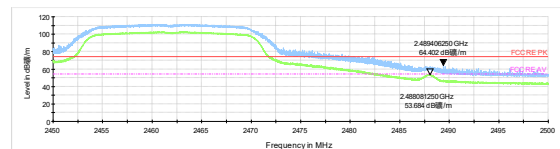

802.11g-Channel 11 Peak+ Average

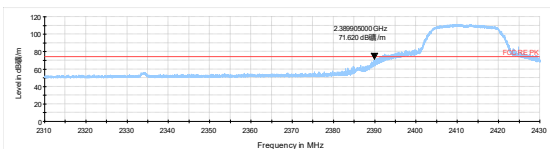

802.11g-Channel 1 Peak+ Average

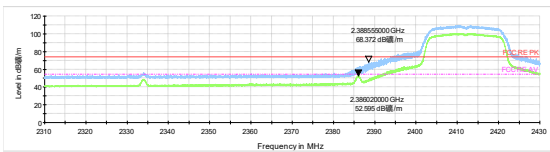

802.11n HT20-Channel 1 Peak+ Average

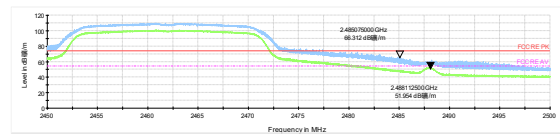

802.11n HT20-Channel 11 Peak+ Average

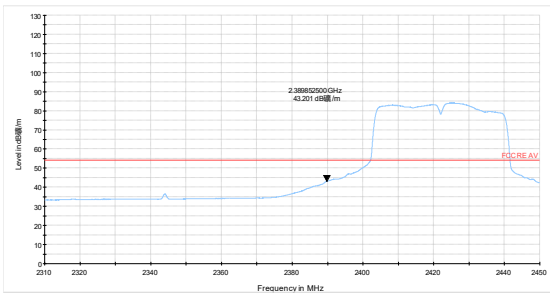

802.11n HT40-Channel 3 Peak+ Average

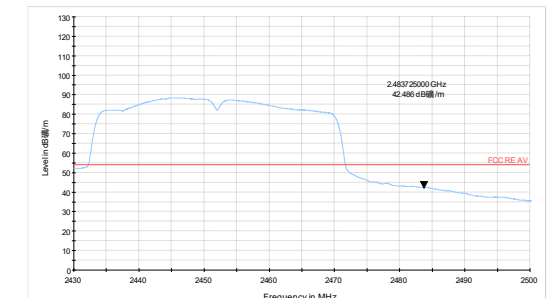

802.11n HT40-Channel 9 Peak+ Average

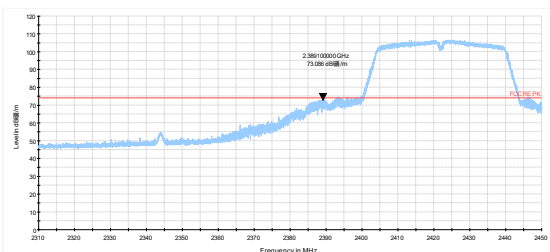

802.11n HT40-Channel 3 Peak+ Average

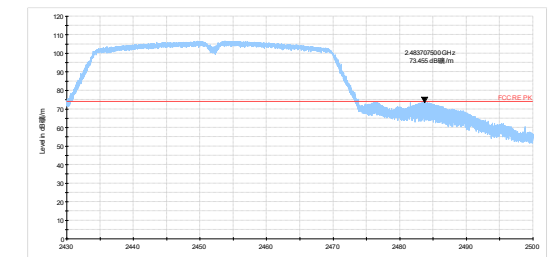

802.11n HT40-Channel 9 Peak+ Average

After the pretest, Bluetooth LE (2M) was selected as the worst Mode for Bluetooth LE.

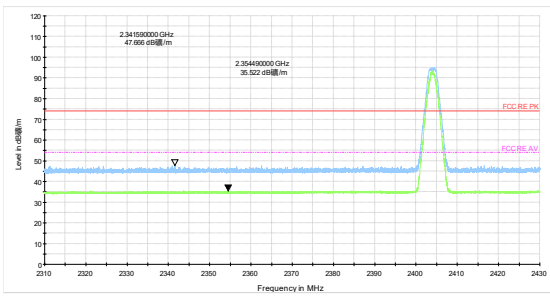

Bluetooth LE (2M) Channel 0 Peak+ Average

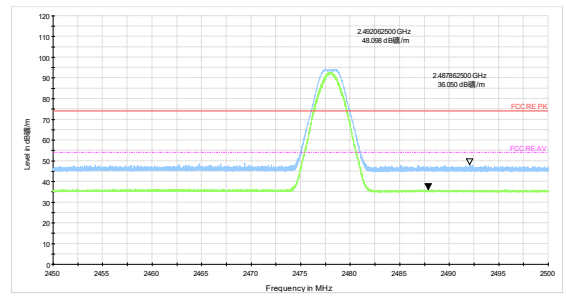

Bluetooth LE (2M) Channel 39 Peak+Average

Result of RE

Test result

Sweep the whole frequency band through the range from 9kHz to the 10th harmonic of the carrier, the Emissions in the frequency band 18GHz-26.5GHz are more than 20dB below the limit are not reported.

The following graphs display the maximum values of horizontal and vertical by software. For above 1GHz, Blue trace uses the peak detection, Green trace uses the average detection.

Continuous TX mode:

Remark:

1. **Correction Factor = Antenna factor + Insertion loss (cable loss + amplifier gain)**
2. **Margin = Limit – Quasi-Peak/ MAX Peak/ Average**
3. **For below 1GHz**

~ QP Level @Spectrum Overview H
 ~ QP Level @Spectrum Overview V
 ◆ QP Level @Final Results
 — QP Limit

For above 1GHz

~ PK Level @Spectrum Overview H
 ~ PK Level @Spectrum Overview V
 ◆ PK Level @Final Results
 — PK Limit
~ AVG Level @Spectrum Overview H
 ~ AVG Level @Spectrum Overview V
 ◆ AVG Level @Final Results
 — AVG Limit

Wi-Fi 2.4GHz

During the test, the Radiates Emission from 9kHz to 1GHz was performed in all modes with all channels. The test data of the worst-case condition was recorded in this report.

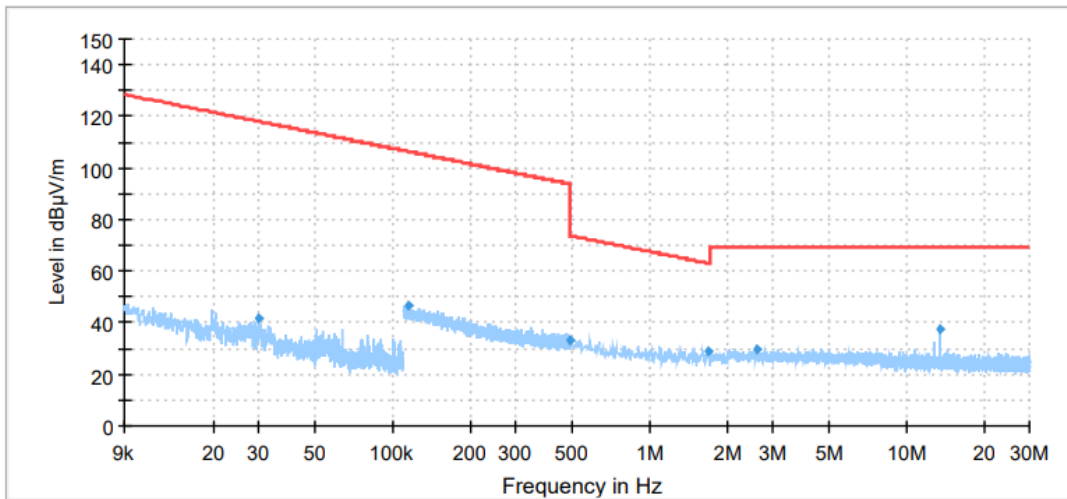

Final Result

Frequency (MHz)	MaxPeak (dBµV/m)	Limit (dBµV/m)	Margin (dB)	Meas. Time (ms)	Bandwidth (kHz)	Pol	Azimuth (deg)	Corr. (dB/m)
0.03	41.54	118.05	76.51	500.00	0.200	V	359.00	17
0.11	46.71	106.47	59.75	150.00	9.000	V	353.00	17
0.49	33.56	93.80	40.24	150.00	9.000	V	8.00	17
1.69	29.35	63.02	33.68	150.00	9.000	V	105.00	17
2.60	29.96	69.50	39.54	150.00	9.000	V	339.00	17
13.49	37.52	69.50	31.98	150.00	9.000	V	185.00	17

Radiates Emission from 9kHz to 30MHz