

Robot Vacuum Cleaner

User Manual

USER'S GUIDE **V100**

Please read this instruction carefully before using the product and keep it properly

OPERATING INSTRUCTION

Cautions

- The product should not be used by children under 8 years old or persons with reduced physical or mentally disabled alone. Please be sure it's under the instruction and supervision of the guardian if they need to use the product. Children and pets shall not ride on or play with the product.
- Do not use this device on an unfinished, unsealed, waxed or rough floor. It may result in damage to the floor and this device. Use only on hard floor surfaces or low pile carpet.
- If the room to be cleaned has a balcony or stairs, a physical barrier should be used to prevent access to the balcony or stairs and to ensure safe operation.
- Do not use the Robot Vacuum in an environment above 113°F or below 32°F.
- Do not use the Robot Vacuum around the fire or fragile objects.
- Do not use the Robot Vacuum to pick up any flaming objects (such as lit cigarette butts).
- Do not use the Robot Vacuum on a wet or sticky floor.
- Do not put your hair, clothes or any part of your body close to the running parts of the Robot Vacuum when the Robot Vacuum is working.
- Do not let the Robot Vacuum pick up objects in a big size that may block the suction port. When the suction port is blocked, please clean it in time to ensure smooth air circulation at the suction port.
- Do not block the suction port, please clean the dust, cotton wool, hair, etc. at the suction port in time and ensure air circulation at the suction port.
- Do not use the Robot Vacuum to pick up any sharp objects (such as glass, nails, etc.).
- Do not use a damaged charging dock. If the charging dock is damaged, it must be repaired by a professional or changed into a new one in order to avoid any danger.
- Please follow the instructions in the manual. The responsibility for any loss or injury caused by improper use of the user will be on the user side.

OPERATING INSTRUCTION

Product Maintenance and Disposal

- Make sure that the roller brush, side brush and dust box are all installed in place before using the Robot Vacuum.
- Do not use any third-party charger or charging dock.
- Unplug the product from the outlet and turn off the power switch before cleaning and maintaining the product.
- Do not wipe or clean the charging contacts with a damp cloth or wet hands.
- If the power cord is damaged, please contact customer service to replace it as soon as possible in order to avoid danger.
- If the product will not be used for a long time, please power off the product to protect the battery.
- Before discarding the product, remove the product from the charging dock, turn it off and remove its battery. Discarded batteries must be disposed of in accordance with local laws and regulations.
- Do not burn down the product no matter how much it is damaged, because the battery of the product may cause an explosion.

Package List

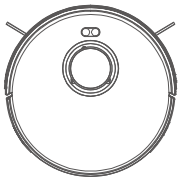

Robot Vacuum



Charging Dock

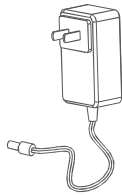

Adapter

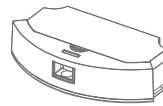

Dustbin

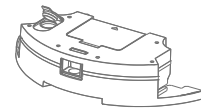

Water tank



Remote Control

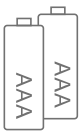

AAABattery
for remote control x2



Cleaning
Tool

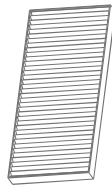

Sponge Filter



Mop

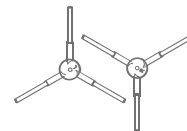

Side Brushes



Manual

Product Presentation

Front

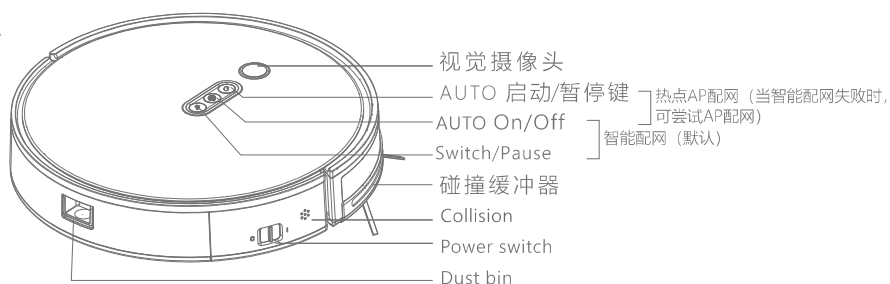

Docking station

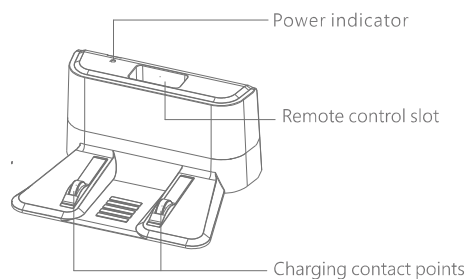

Reverse Side

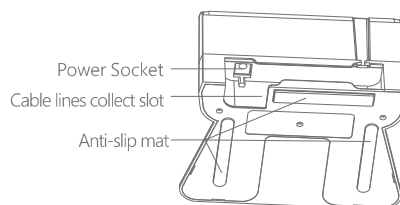
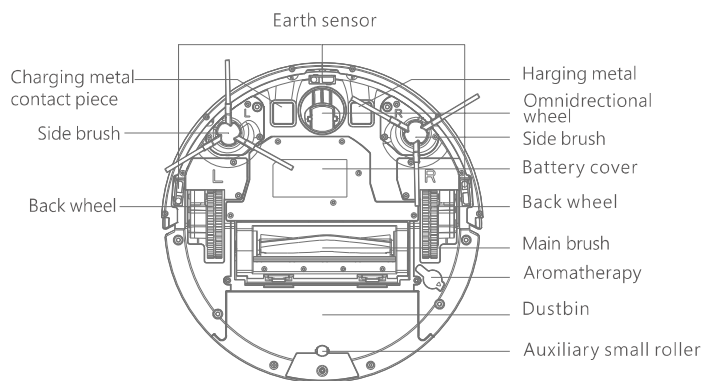

Product Presentation

Dust box

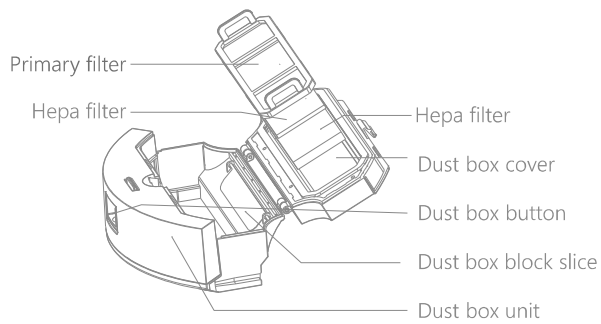

Remote control

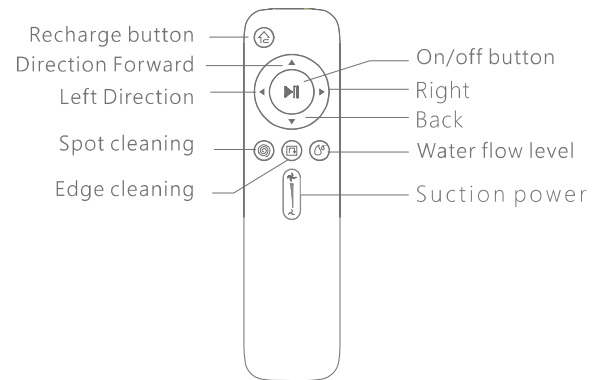

Preparation

Remove objects on the floor

(such as loose paper, power cord etc.) :
Prevent the Robot Vacuum from dragging or sucking in the objects which may block the suction port.

Remove the EVA sponge in each side

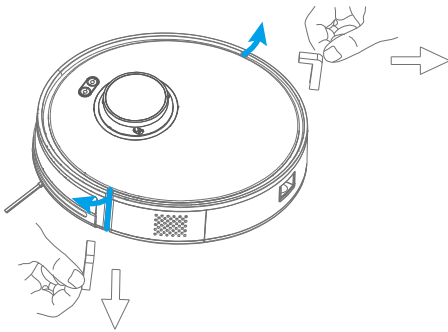

Place the Charging Dock

Place the charging dock on a hard, level surface and against a wall. Remove objects within 3 ft/1 m of the left and right side and within 6 ft/2 m of the front of the charging base. Plug one end of the adapter into the power socket on the Charging Dock and the other end into a wall outlet, and please make sure the the LED indicator on the Charging Dock is Lit. (please do not place the power cord on the floor)

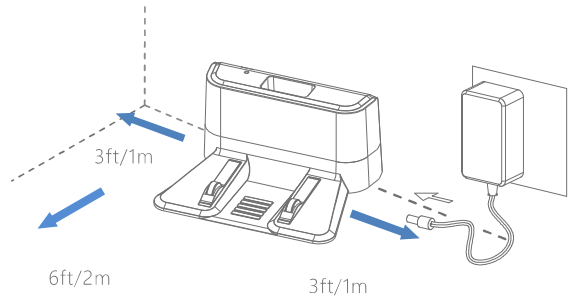

Note:

1. Please avoid direct sunlight on the charging dock.
2. When there is a highly reflective item around the charging base, please remove or cover its bottom of 10cm.
3. It is recommended to place the charging dock in a fixed position, and do not move the charger during the cleaning, or the robot vacuum will not be able to find the charging dock for charging.

Preparation

This product can only be used with adapters, batteries and charging stands shipped with the unit. Otherwise, it may result in product damage, electric shock or fire caused by high voltage. Unplug the plug from the socket before maintenance. Do not touch the power plug or product when your hands are wet, otherwise it may cause electric shock. If the cord of the power adapter is damaged, it must be replaced by the manufacturer, their maintenance department or similar professional to avoid danger.

Install the side brush

Install the edge brush on both sides of the bottom roller of the main engine

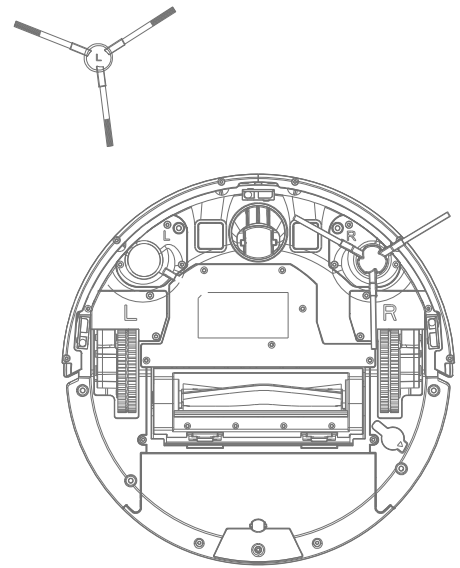
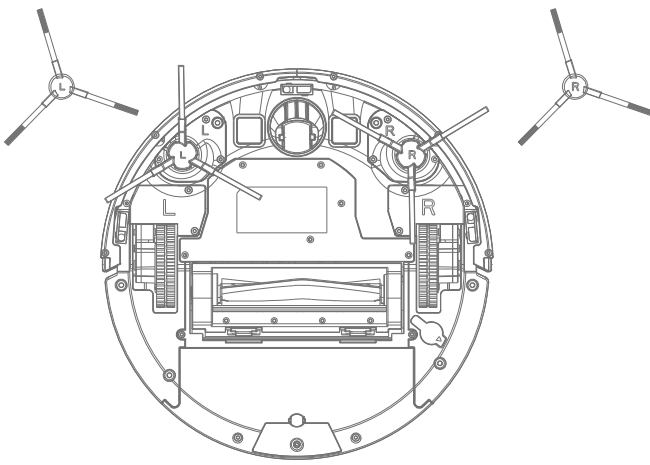

Preparation

2. Product operation Charging

1. Charging method: direct charging, automatic recharging, remote control recharging
- A. Direct charging: the charging base is connected to the power supply, and the automatic charging electrode of the host is aligned with the electrode of the charging base, then the charging can start.
- B. Automatic recharging: in the process of automatic cleaning, when the electric quantity is less than 10%, the machine will automatically look for a charging seat to charge.
- C. Recharge by remote control

Note:



1. Recharge the battery until it is fully charged, so as to prolong the battery life. The first charge lasts about five hours.
2. Please keep the charging base in the energized state. Otherwise, the machine cannot find the charging seat to recharge.
3. When the machine presses the side switch during charging, it is normal for the machine to have no reaction.

Recharge Button "⏻" Indication in Charging	
Charging Status	Indicator of Recharge Button "⏻"
Low power/Back to charge	Flashing blue light
Charging	Breathing blue light
Charging completed	blue light off

Power on/pause/shut down

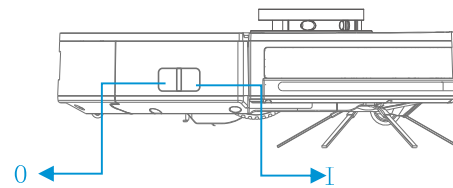
1. Turn on the power switch on the side of the main engine. "I" is turned on, "O" is turned off



2. Press  to start cleaning (start up the default "zig-zag" shape cleaning mode).
3. Press the  button again to stop cleaning (the machine is in standby mode)
4. The device is not working if it is off docking station. The robot will be in stand by mode. If the robot doesn't work for a long time, please disconnect the power.

Preparatory work

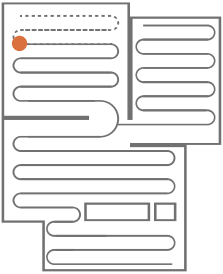

Auto Cleaning

The machine defaults to automatic cleaning mode after the power-on button. The machine will clean the room in the way of "bow" movement, and adjust itself according to different family environment.

Spot Cleaning

It is applicable to the ground area where garbage is concentrated. The machine can carry out centralized cleaning in a spiral shape in the designated area.

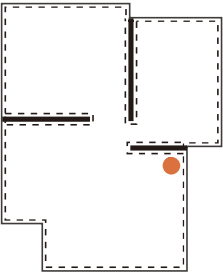
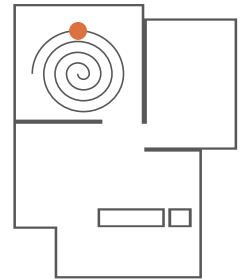

Edge Cleaning

The machine cleans the corner edge one week.

Schedule Cleaning

Cooperate with mobile APP to set appointment time.
(Note: The default mode of APP reservation cleaning is automatic cleaning).



APP Operation

App needs to be used in the networked state and please connect to the home network first. Make sure the network is normal.

Download 1. Scan the QR code and download "Tuya Smart APP".
For ISO model phones, search for "Tuya Smart" in the APP store to download;

For Android model phones, search for Tuya Smart in the app store to download.

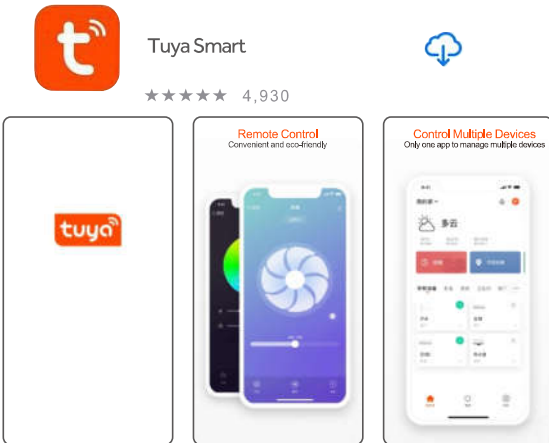

Sign up:
New users enter the regist
New Account. Use an unreg
and set a login password by
After registration, you can

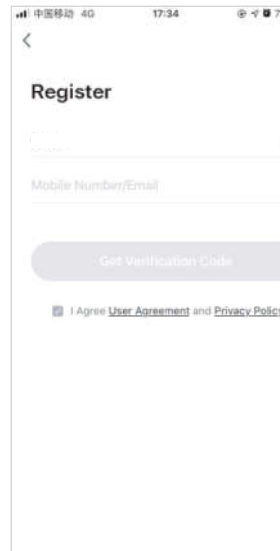

3:03



Register

China

Mobile Number/Email

Get Verification Code

I Agree User Agreement

APP Operation

log in:

If you have an account, enter your account and password in the APP login interface to log in. If you forget the password, click Forgot Password, enter the registered mobile phone number/ email, and obtain the verification code to log in to the account.

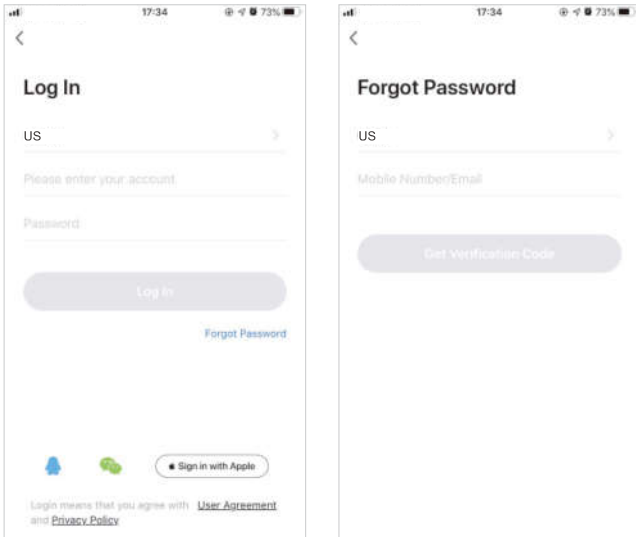

Add device:

1. After login, click Add Device;
2. Click "Small Appliances" and then "robot vacuum cleaners"

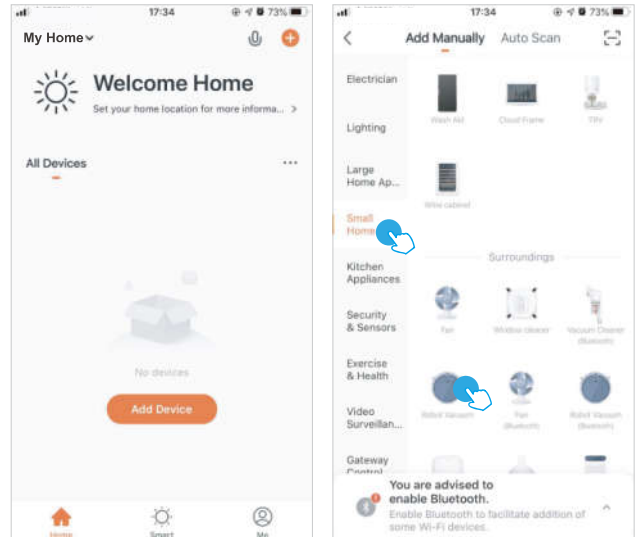

APP Operation

3. Connect to the regional wifi (2.4GHz), enter the password then click Next; At the same time, long time press the device's cleaning button (🧹) and recharge button (🔋) to the voice prompt "Network configuration, please wait for the network configuration result in the APP interface". The device WIFI indicator flashes);

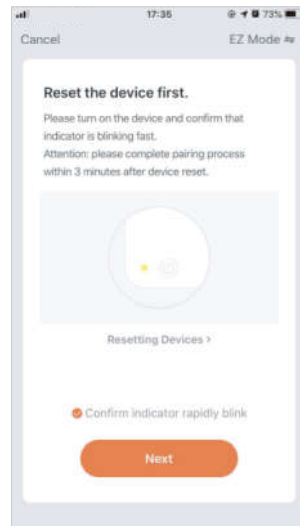
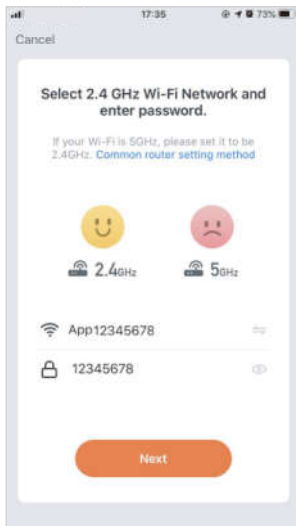

4. Check "Confirm that the indicator light is flashing fast" and click Next;
5. Show that the robot vacuum cleaner is being added;
6. Click Finish after adding successfully;

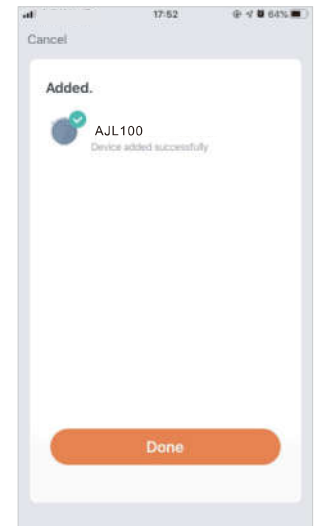
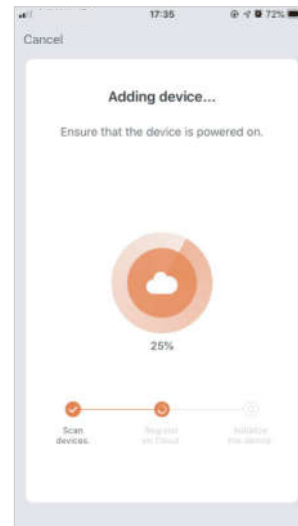

Product maintenance

Dust box and filter cleaning

It is recommended to clean the dust box and filter in time after each use of the machine

A. Pull out the dust box by pressing the button on the back of the machine

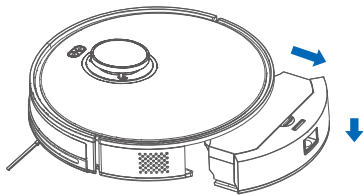

B. Press and hold the button on the dust box to open the dust box and take out the garbage.

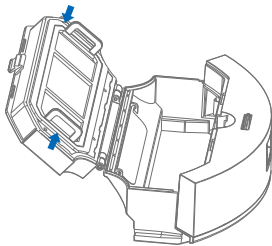

C. Take out the filter filter cotton inside the dust box, and clean it with a brush or cloth.

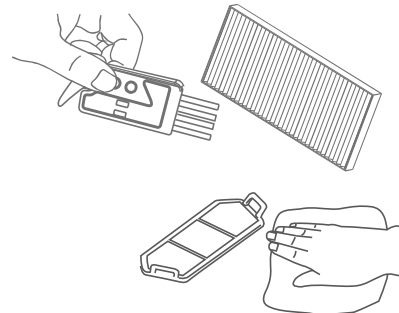
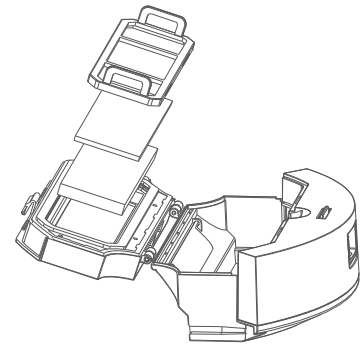

Remark:

1. The life of the filter is about 24 months. It is recommended to wash it with water every 15-30 days.
2. After washing, it is recommended to dry in a cool and ventilated place. Do not squeeze. Do not expose to the sun.

Product maintenance

2. Main brush assembling and cleaning

- A. Take out the roller brush cover of the dust suction port with the bottom of the machine facing upwards, pull up the roller brush on the right side, and then use the cleaner to clean the entangled hair.
- B. After the roller brush is rinsed and dried, align the ports one by one and install them.

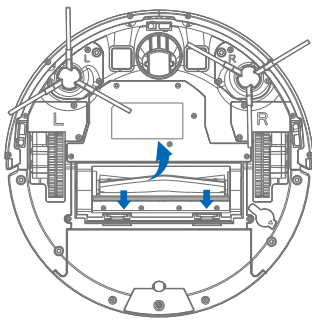
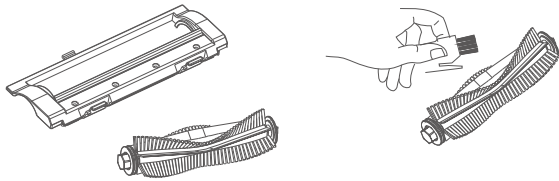

3. Side brush cleaning

- A. Use a brush cleaning tool to cut off the entangled debris.
- B. Use a clean cloth to clean the side brush.

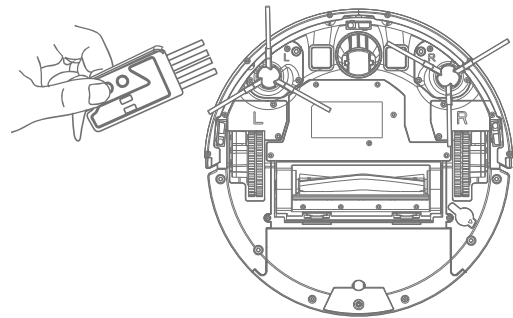
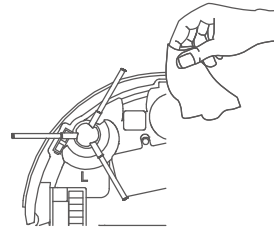

Product maintenance

- C. When the side brush is in use, if the side brush is deformed, please remove the side brush and restore it to its original shape with boiling water.
- D. When the side brush cannot be used, please remove the damaged side brush and replace it in time

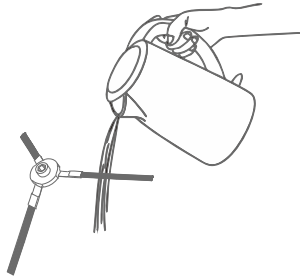

Universal wheel cleaning

Turn the device over, pull out the universal wheel upwards, reinstall it after cleaning, and press it firmly.

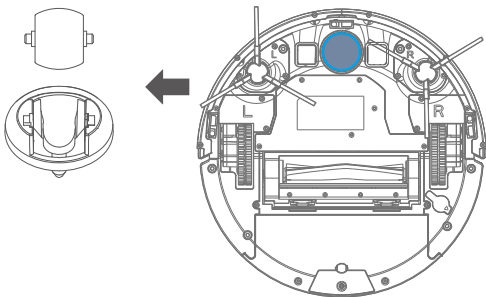

Ensor and charging electrode cleaning

Use a cleaning tool or a rag to clean the device ground sensor, charging pole piece, suction channel opening and charging contacts on the charging stand.

Note: Do not directly touch the sensor with liquids such as water and thinner.

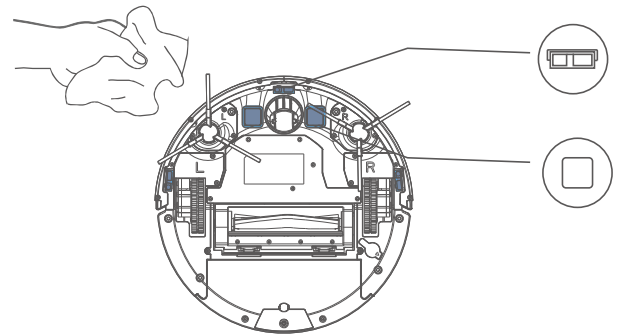
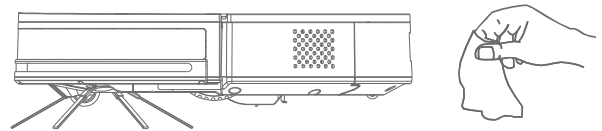

Problem type

No	Fault conditions	Possible reason	Solution
1	Cannot connect to the APP	The router username and password are incorrect.	Configure the router network and make sure that the router "Username" and "Password" are entered correctly.
		The device is not within the network signal coverage of the router.	Ensure that the device is within the network signal coverage of the router.
		Whether the device is in a state to be configured.	The network can only be configured when the host is in the network configuration state. After the device is normally powered on, press and hold the fixed-point button and the recharge button. Then you will hear "Network configuration, please wait for the network configuration result in the APP interface," it means The device enters the network configuration mode.
		Without 2.4G network.	Please change to 2.4G network
2	Can't install APP	The phone operating system version is too low.	Mobile phones with IOS9.0 and above, Android5.0 and above can download and use the App
3	Can not be charged	The main unit is in poor contact with the charging pole piece of the charging station.	Make sure that the unit and the charging pole piece of the charging station are fully connected. And the indicator light on the charging station is Always on. Check whether the charging pole pieces of the main unit and charging stand are dirty.
		The charging dock is not connected to power.	Connect the charging station power supply in time.
4	Difficult to recharge	The charging stand is not placed correctly.	Please place the charging station on a level ground against the wall. And remove 1 meter on both sides of the charging station. All obstacles of 2 meters, covering the bottom of the reflective objects around the charging station 10cm.
		The charging station is powered off or moved off.	Please check if the charging base is connected to a power source. Do not move the charging stand position artificially.
		The unit is stuck by ground obstacles (such as wires, carpet edges, electric fan base, etc.) or the door of the room with the charging stand is closed. Making it impossible to return to the charging stand.	It is recommended to clean the ground debris and wires before using the machine to avoid being entangled when the main machine is working and unable to get out of the trap and recharge.
		Pause for more than 60 minutes or move more than 1 meter midway.	Please avoid suspension and moving as much as possible. To ensure the smooth operation of the machine. Please let the machine complete the cleaning independently. The pause time should not exceed 60 minutes as much as possible, and the moving distance should not exceed 1 meter
		The unit does not start cleaning from the charging stand.	It is recommended to let the unit start cleaning from the charging station.

Problem type

No	Fault conditions	Possible reason	Solution
5	When the unit is working, there are random deviations of the route, repeated cleaning and the community Domain missed scanning, etc.	Wires, slippers and other objects placed on the ground affect the normal operation of the host.	Please minimize the placement of scattered items on the ground. It is recommended to clean up the ground debris before using the machine. If there is a missing scan, the machine will make up for the leakage. Please don't For interference (such as moving the host or blocking the path of the unit)
		Use the unit in low or no light conditions	It is recommended to use the machine under good light or lighting conditions.
		Working on a newly waxed and polished floor, causing flooding friction between the driving wheel and the ground is reduced.	It is recommended to wait for the floor wax to dry before using it.
		It is possible to caused by driving wheel and the ground slip when the robot vacuum cleaner climbs small steps, thresholds, and door bars, which affects the host's overall impact judgment of the working environment of the housing estate.	It is recommended to close the door of the area and clean the area separately. The device dhas the function of self-identifying single rooms. And it will return to the starting point after cleaning, please rest assured to use.
		Due to different environments unit in individual regions cannot enter Clean up.	It is recommended to tidy up the home environment to ensure that the unit can enter for cleaning.
6	The unit is in trouble while working.	The unit is entangled or obstructed by scattered wires, drooping curtain cloth or carpet fringing on the ground.	The host will try various methods to get out of the trouble. It is recommended to help manually.
		He main unit may be jammed by furniture close to the height of the main unit.	It is recommended to elevate furniture or artificially block it.
7	When the unit is working, the running sound is loud.	Side brushes and roller brushes are entangled, dust box, filter materials are blocked, etc.	It is recommended to clean the dust box in time after each use of the machine; regularly clean and maintain side brushes, roller brushes, dust boxes, filter materials, etc.f
8	The suction power becomes smaller	The suction port is blocked.	Please clean up the dust suction port in time.
		The dust box is full.	Please clean the dust box in time.
		The filter unit is dirty.	Take out the filter cotton and place it in a cool place to air dry.
		The filter cotton is moist.	Take out the filter cotton and place it in a cool place to air dry.

Product parameters

If the above methods cannot solve the problem, you can try the following:

1. Turn on the power switch on the side of the unit again and restart the machine.
2. If the machine keeps moving backwards, please pat the bumper with your hand and restart it.
3. If the machine does not move forward, please check whether the cliff sensor is blocked and lean the dust on the sensor cover.
4. If the problem cannot be solved by restarting, please return the machine to the after-sales service center for repair.

Tips :

1. The visual sweeper has the function of automatically recognizing the direction of the family, and will walk horizontally and vertically during the cleaning process.
2. The visual navigation machine has a repositioning function. When using this function, the machine needs to be paused first and be in the area that has been cleaned, otherwise the positioning will fail.

Complete unit parameters

Name	Parameter
Size	L320*W320*H76mm
voltage	14.8V
ated power	32W
Battery	2500mAh or 3000mAh Li-battery
Charging base Output voltage	19V
Charging base output current	1A

Remark: Storage temperature 0-45°C

Docking station parameters

Name	Parameters
Size	L167*W143*H87mm
Rated input	19.0V === 1.0A
Rated output	19.0V === 1.0A
Rated power	50/60Hz



Product parameter

Name and content of hazardous substances in the product

Name	Parts					
	Lead(Pb)	Mercury(Hg)	Mercury(Cd)	Hexavalent Chromium (Cr(VI))	Polybrominated Biphenyls (PBB)	Polybrominated Diphenyl Ethers (PBDE)
Circuit	×	○	○	○	○	○
Metal partsw	○	○	○	○	○	○
Plastic Casing	○	○	○	○	○	○
Battery	○	○	○	○	○	○
Other parts	○	○	○	○	○	○

This form is compiled in accordance with the regulations of SJ/T 11364.

○ Means that the content of the hazardous substance in all homogeneous materials of the part is below the limit requirement specified in GB/T 26572.

× Means that the hazardous substance at least in a certain homogeneous material of the part exceeds the limit requirement of GB/T 26572.



FCC Warning

This device complies with part 15 of the FCC rules. Operation is subject to the following two conditions: (1) this device may not cause harmful interference, and (2) this device must accept any interference received, including interference that may cause undesired operation.

Changes or modifications not expressly approved by the party responsible for compliance could void the user's authority to operate the equipment.

NOTE: This equipment has been tested and found to comply with the limits for a Class B digital device, pursuant to part 15 of the FCC Rules. These limits are designed to provide reasonable protection against harmful interference in a residential installation. This equipment generates uses and can radiate radio frequency energy and, if not installed and used in accordance with the instructions, may cause harmful interference to radio communications. However, there is no guarantee that interference will not occur in a particular installation. If this equipment does cause harmful interference to radio or television reception, which can be determined by turning the equipment off and on, the user is encouraged to try to correct the interference by one or more of the following measures:

-Reorient or relocate the receiving antenna.

- Increase the separation between the equipment and receiver.
- Connect the equipment into an outlet on a circuit different from that to which the receiver is connected.
- Consult the dealer or an experienced radio/TV technician for help.

Radiation Exposure Statement

To comply with FCC RF exposure compliance requirements, this grant is applicable to only mobile configurations. The antennas used for this transmitter must be installed to provide a separation distance of at least 20cm from all persons and must not be co-located or operating in conjunction with any other antenna or transmitter.

Warranty Card

Model		
Warranty	Robot vacuum cleaner	Date
User name	User name	
	Add:	
Store	User name	
	Add:	

1. Please keep your product warranty card properly
2. When you need to maintain the product, please fill in the warranty information completely to ensure that the font is neat and clear and easy to identify
3. When you enjoy the after-sales service, please show the product warranty card and related purchase information. For online purchases, please provide the corresponding platform purchase account and enjoy the relevant after-sales service
4. You can call our national after-sales service hotline

Warranty period

Product	Time
Completed unit	1 year
Battery	6 months
Adapter	6 months
Consumables side brush, cleaning brush tool	NO

Warranty principle

1. If the purchased product has quality problems and has not been damaged or repaired, it can be replaced at the point of purchase within 7 days
2. Purchase this product to enjoy free maintenance during the warranty period
3. The repair-free warranty is invalid in the following cases. But repair services are provided. And the corresponding accessories and labor costs will be charged when repairing
 - A. The damage caused by human factors. Including the damage caused by using in abnormal working environment, not according to the instructions, etc.
 - B. Due to the user's private disassembly, self-maintenance, modification, or non-maintenance of the company's maintenance department
 - C. Damage caused by force majeure (such as fire, earthquake, lightning, etc.)
 - D. Without product warranty card and valid proof of purchase and unable to verify user information files
 - E. Unable to verify the date of purchase

